



## Electronic Service Manuals

This electronic document is provided as a service to our customers. We do not create the contents of the information contained in this document. Should you have detailed questions pertaining to the information contained in this document, you may contact Michco, or the manufacturer which provided the original information in this electronic deliverable. Michco's only part in this electronic deliverable was the electronic assembly process. By providing this manual on line we are not guaranteeing parts availability.

You may contact Michco through the following methods:

Phone (517) 484-9312 or (800) 331-3339

2011 N. High St. -- Lansing, Michigan -- 48906

Fax: (517) 484-9836

Email: [CustServe@Michco.com](mailto:CustServe@Michco.com)

Web site: [www.Michco.Com](http://www.Michco.Com)

Parts Web site: [www.FloorMachineParts.Com](http://www.FloorMachineParts.Com)

Order Parts on Line at:

**[www.FloorMachineParts.Com](http://www.FloorMachineParts.Com)**

Directly to Parts & Service:

By Email: **[Shop@Michco.com](mailto:Shop@Michco.com)**

By Fax: (517) 702-2041

By Voice: Use numbers above.

**Serving the Cleaning Industry Since 1922**

Notice: All copyrighted material remains property of original owners, all trademarks are property of respective owners. Manuals are subject to Manufacturer's reproduction limitations. Originals or reproductions were provided by manufacturers through a request. We make no warranty as to the correctness of information provided in this document and you assume all risk. By placing these manuals on line we are not declaring our corporation to be an manufacturer authorized dealer or provider, please check our web site for authorized manufacturers we represent.



**E83015-00**  
**E83016-00**



**CREWMAN™ 1600**  
**CREWMAN™ 2000**

**20" High Speed  
Electric Burnishers**



**Operator and Parts  
Manual**

## **SPECIFICATIONS**

- **Burnishing Path/Pad Size:** 20"
- **Motor:** 1.5 hp, 120v, 15 A, 50/60 HZ
- **Pad Pressure:** 15 lbs.
- **Pad Speed:** 1600/2000 RPM
- **Drive System:** V-Belt
- **Power Cord:** 75' 14/3 Safety Yellow
- **Handle Grips:** Anti-Fatigue
- **Operating Wheels:** 5" Non-marking
- **Transport Wheels:** 4" Non-marking
- **Productivity:** 10-15,000 sq.ft. / Hour
- **Weight:** 70 lbs.
- **Dimensions:** Length 33.75", Width 21", Height 50"

## **!WARNING! IMPORTANT SAFETY INSTRUCTIONS**

**Carefully read and understand this manual before operating this machine.**

**To reduce risk of fire, electric shock, or injury:**

- Do not operate in explosive areas, near flammable liquids or gases.
- Only plug into a properly grounded outlet.
- Do not exposure to rain, store indoors.
- Do not plug in or handle machine with wet hands.
- Do not operate the machine with a damaged cord or plug.
- Do not block or disconnect safety lever.
- Do not leave machine plugged in while unattended.
- Unplug machine before servicing.
- Do not put fingers under the pad or pad holder.
- Unplug the machine before installing or removing the pad.
- Use only high speed burnishing pads.
- Do not put any foreign object into openings. Do not use with any opening blocked; keep free of dust, lint, hair, & anything that may reduce airflow.
- Keep hair, loose clothing, fingers, & all parts of body away from openings & moving parts.
- Turn off all controls before unplugging.
- Do not use in or around flammable or combustible liquids such as gasoline or use in areas where they may be present.
- Connect to a properly grounded outlet only. See grounding instructions.
- Do not use to spray buff
- **WARNING:** This product contains a chemical known to the State of California to cause cancer.

## **GROUNDING INSTRUCTIONS**

This machine must be grounded. If it should electrically malfunction, grounding provides a path of least resistance for electric current to reduce the risk of electric shock. This machine is equipped with a cord having an equipment-grounding conductor & grounding plug. The plug must be plugged into an appropriate outlet that is properly installed & grounded in accordance with all local codes & ordinances.

---

### **! DANGER !**

Improper connection of the equipment-grounding conductor can result in a risk of electric shock. Check with a qualified electrician or service person if you are in doubt as to whether the outlet is properly grounded. Do not modify the plug provided with the machine. If plug will not fit the outlet, have a proper outlet installed by a qualified electrician.

Replace the plug if the grounding pin is damaged or broken.

Extension cords connected to this machine should be 12 gauge, 3-wire cords with 3-prong plugs & outlets. DO NOT use extension cords more than 50 feet long.

## **OPERATING INSTRUCTIONS**

**Check machine for damage to cord or plug.**

**Use only Hi Speed Burnishing pads 20" or 19" diameter.**

**To install or change the pad:**

1. Unplug the machine.
2. Tip the machine back on the wheels.
3. Remove the center-lock.
4. Center the pad on the pad driver.
5. Replace the center-lock and tighten securely.

**To operate the machine:**

1. Plug into a grounded outlet.
  2. Release the handle and lower it.
  3. The handle can be locked into a comfortable position for the operator or used free floating.
  4. Press the safety lever and squeeze the trigger to start the machine.
  5. Do not operate in one place as damage to the floor or finish could result.
  6. Do not operate the machine with the handle in the upright position.
  7. Remove the pad after every use.
  8. Store the machine tilted back on the transport wheels.
  9. Use only new or clean pads and reverse them as needed.
- 

## **MAINTENANCE INSTRUCTIONS**

To maintain appearance – wipe the machine with a damp cloth after use.

**Warning** – Unplug the machine before servicing

Check the following:

1. Check the motor brushes for wear or excessive arcing.
2. Check belt tension.
3. Check the cord and electrical system.
4. Check the safety lockout on the trigger.
5. Check wheels and bearings.

# HANDLE PARTS BEFORE SERIAL NUMBER 0438426

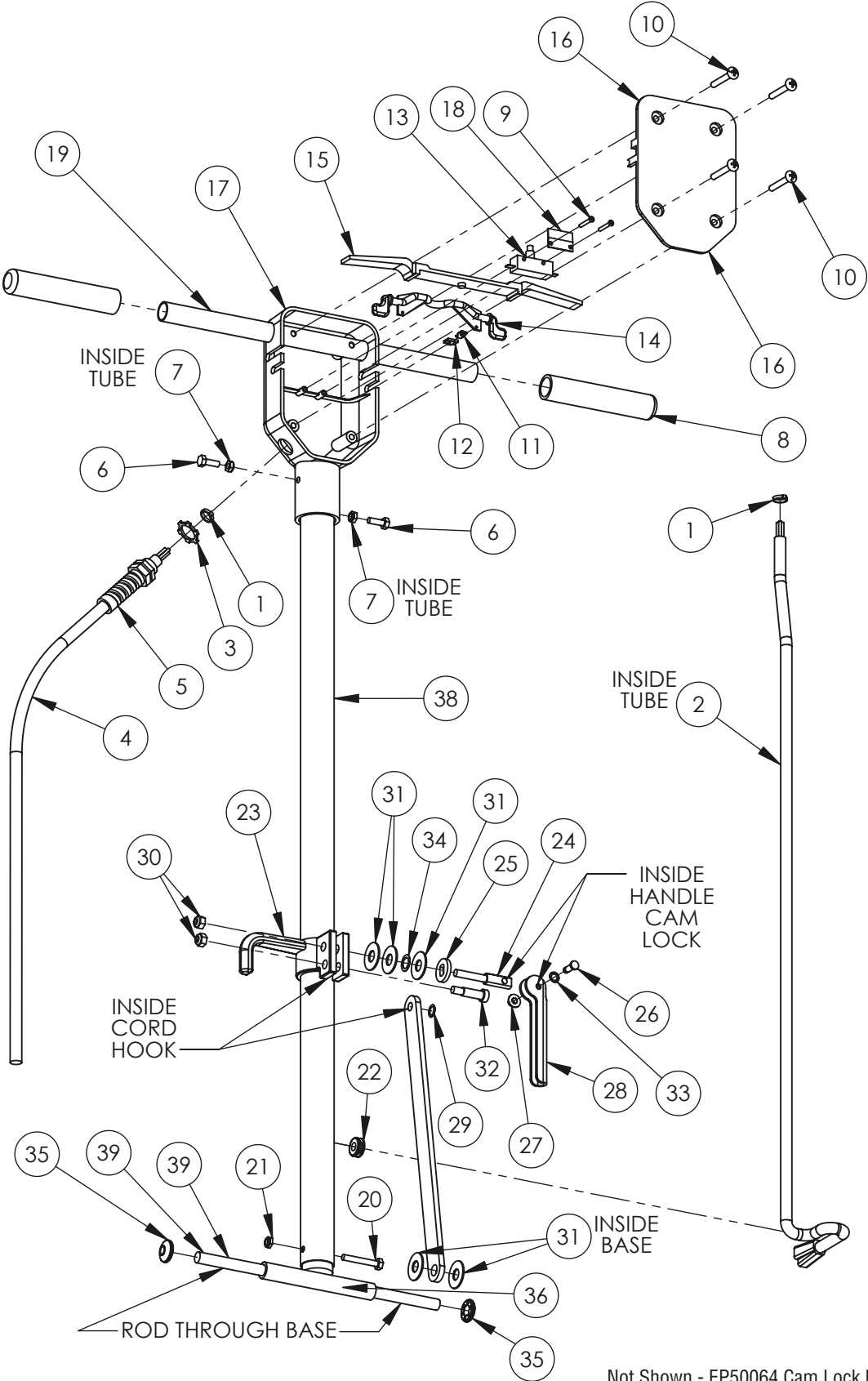

Not Shown - EP50064 Cam Lock Handle Asm

## HANDLE PARTS BEFORE SERIAL NUMBER 0438426

ITEM#	PART#	DESCRIPTION	QTY.
1	E83523	NYLON CABLE TIE	2
2	E83132	CORD, HANDLE, 14-3	1
3	E83789	NUT, ELECTRICAL CONDUIT, 1/2"	1
4	E83131	CORD, 75 FEET, 14-3 ST	1
5	E89602	CORD STRAIN RELIEF, METAL	1
6	E81064	BOLT, HEX, 1/4-20 x 3/4	2
7	E83520	NUT, NYLOCK, 1/4-20	2
8	E83127	GRIP	2
9	E83427	SCREW, PHILLIPS, No. 6 x 1	2
10	E83426	SCREW, PHILLIPS, 1/4-20 x 1.75	4
11	E83130	SPRING	1
12	E83270	CLIP, SPRING	1
13	E85032	SWITCH	1
14	E83129	SAFETY LOCK	1
15	E82752	TRIGGER, SWITCH	1
16	E83325	COVER, SWITCH BOX	1
17	E82750	SWITCH BOX, HANDLE, SINGLE SPEED	1
18	E81105	PLATE, SWITCH	1
19	E83451	HANDLE TUBE, 7/8 x 16	1
20	E81065	BOLT, HEX, 1/4-20 x 1-3/4, GRADE 5	1
21	E81070	NUT, NYLOCK, 1/4-20	1
22	E83519	GROMMET, .375 ID	1
23	E83137	CORD HOOK	1
24	E83133	BOLT, ADJUSTABLE, CAM, 5/16-18	1
25	E83135	OVAL WASHER	1
26	E83266	PIN, .25 x .75	1
27	E83268	CAP, PUSH, .25	1
28	E83133	HANDLE, CAM LOCK	1
29	E81379	WASHER, SPRING, 3/8	1
30	E81063	NUT, NYLOK, 5/16-18	2
31	E83145	WASHER, NYLON	5
32	E81077	BOLT, SHOULDER, 3/8 x 1	1
33	E83133	WASHER, SPRING, 1/4	1
34	E83269	WASHER, SPRING, 1/2	1
35	E83143	CAPS, AXLE, 0.5	2
36	E82717	HANDLE ATTACHMENT, WELDED "T"	1
37	E83136	BRACKET, FLAT, HANDLE	1
38	E83711	HANDLE TUBE	1
39	E83452	AXLE, 1/2 x 12.375	1
Not Shown	PE50064	Cam Lock Assembly	1

# HANDLE ASSEMBLY AFTER SERIAL NUMBER 0438426

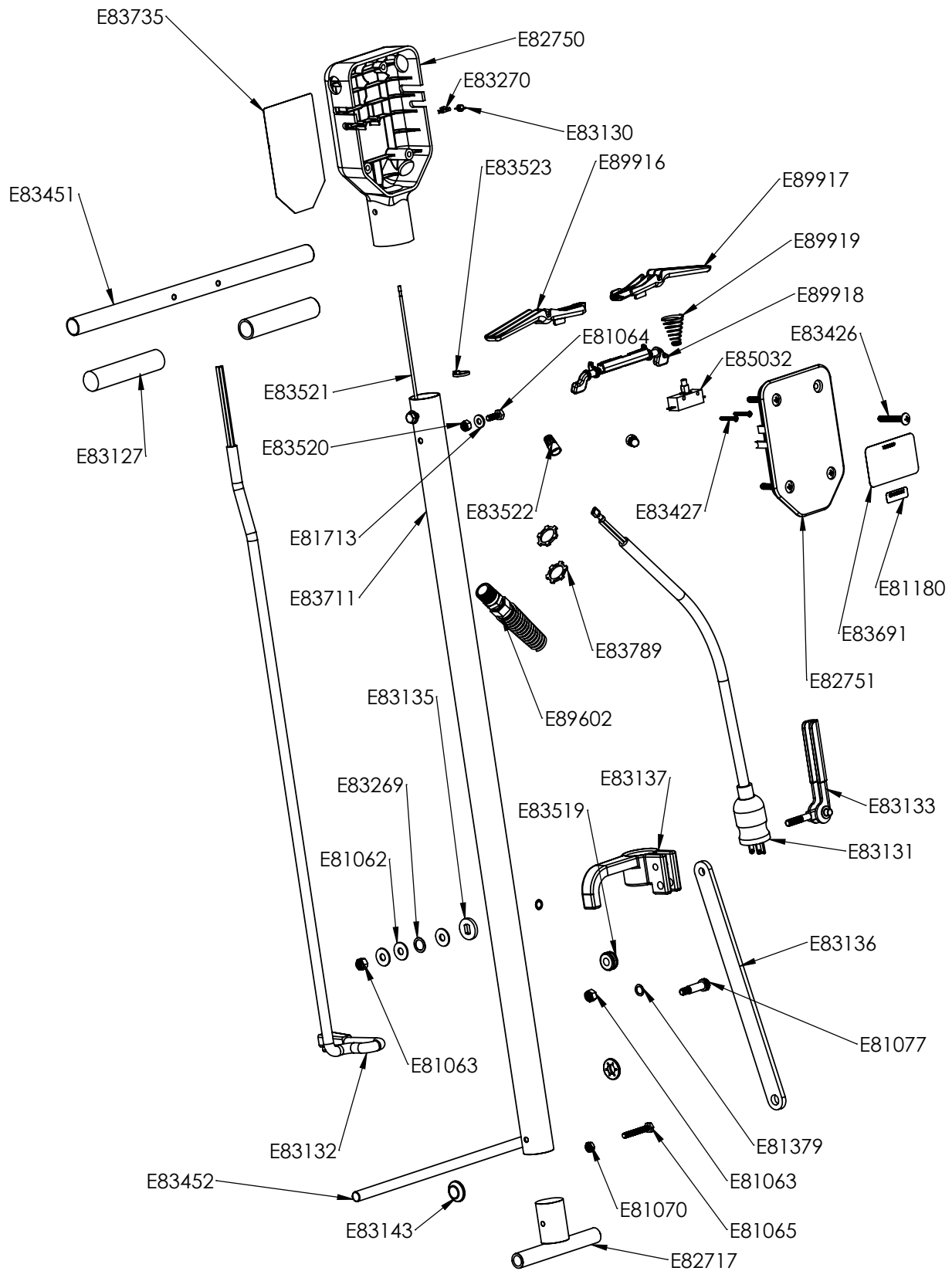

# HANDLE PARTS AFTER SERIAL NUMBER 0438426

PART #	DESCRIPTION	QTY.
E50078	Handle ASM Floor Machine	1
E83711	MAIN HANDLE TUBE	1
E82750	Switch Box, Handle, Black	1
E83520	NYLOC HEX NUT 1/4-20	2
E83789	Strain Relief Nut, Metal	2
E83427	Screw 6-32 x 1.00 Lg	2
E83426	TRUSS HD SCREW, 1/4-20 x 1.750 LG ZINC	4
E83523	Cable Tie 4.125 Lg x 0.125 W	1
E83130	Spring, Extension	2
E83691	Decal, Warning	1
E83270	Spring Clip	2
E81064	HEX BOLT 1/4-20 x 0.75 LG ZINC	2
E81065	Hex Hd Bolt, 1/4-20 x 1-3/4 Lg, Zinc	1
E81070	THIN NYLOC NUT, 1/4-20	1
E85032	SWITCH, 25 AMP, 1.5 HP, 125 VAC	1
E83132	Handle Cord 14-3	1
E83132	Handle Cord	1
E83519	GROMMET, 1/8 W x 5/8 GROOVE	1
E83521	GREEN GROUND WIRE	1
E83521-01	14 AWG WIRE, 5.0	1
E83521-02	TERMINAL, RING, 16-14 GA, 0.197 STUD DIA, NON INSULATED	1
E83522	WIRE, NUT YELLOW	2
E83131	Cord, 14-3 x 75 ft STW Yellow	1
E83131	75 FT YELLOW CORD	1
E83131-02	Terminal, 14-16 AWG, Female, Quick Disconnect, Insulated	1
E83127	Handle Grip 7/8 ID	2
E82751	Cover, Switchbox	1
E83451	HANDLE GRIP TUBE	1
E82717	Handle Socket	1
E83137	HANDLE LOCK CORD HOOK	1
E81713	FLAT WASHER 1/4	2
E81180	SERIAL DECAL	1
E81077	Shoulder Screw 0.3125 x 18, 0.375 x 1	1
E81379	SPRING WASHER, 0.375 CRESCENT	1
E81063	Nyloc Hex Nut 0.3125-18 Zinc	2
E89602	STRAIN RELIEF	1
E89602-03	NIPPLE	1
E89602-01	NIPPLE	1
E89602-04	FERRULE	1
E89602-02	SPRING	1
E89919	SAFETY SPRING	1
E89917	SWITCH LEVER	1
E89918	SAFETY LOCK	1
E89916	SWITCH LEVER	1
E83735	Decal, Betco Crewman 2000	1
E83133	CAM LOCK HANDLE	1
E83133-01	CAM LOCK LEVER	1
E83133-02	PIN, 0.25 x 0.75	1
E83133-03	PUSH CAP, 0.25	1
E83133-04	WASHER, 1/4	1
E83133-05	BOLT, ADJUSTABLE, CAM, 5/16-18	1
E81062	Flat Washer 0.3125 Zinc	3
E83269	Spring Washer 1/2 ID	1
E83135	OVAL WASHER	1
E83136	BRACKET, FLAT HANDLE	1
E83143	Axle Cap 1/2 in	2
E83452	AXLE, 0.500 OD x 12.375 Lg	1

# BASE, MOTOR, AND WHEELS

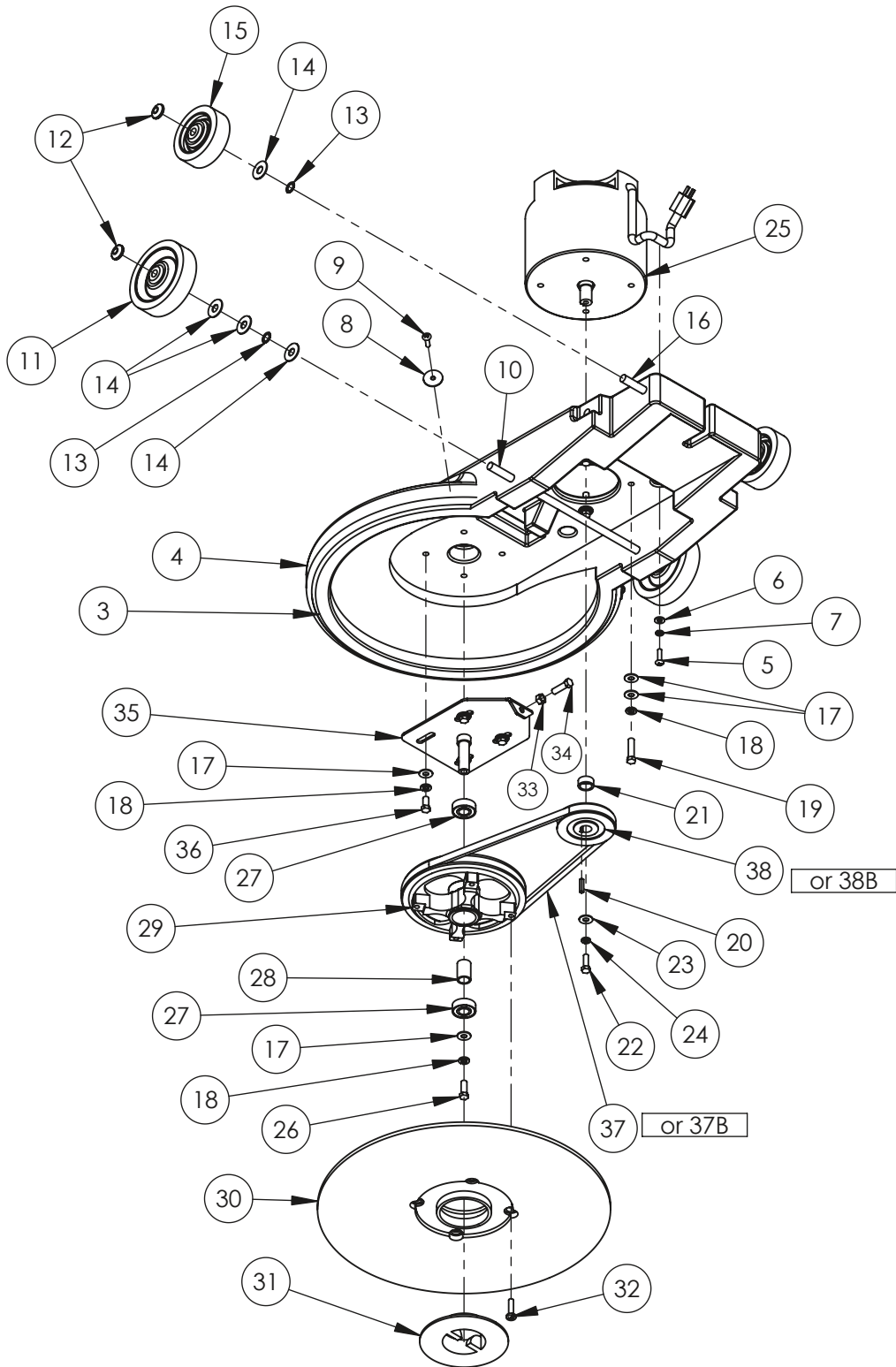

Not Shown - EP50089 - Pad Driver Pulley Asm

## BASE, MOTOR, AND WHEELS

ITEM	SKU	DESCRIPTION	QTY.
3	E83138	BASE, HIGH SPEED	1
4	E83141	BUMPER	1
5	E83570	SCREW, PHILLIPS, 1/4-20 x 1	4
6	E89334	WASHER, FLAT, 1/4	4
7	E81078	WASHER, LOCK, 1/4	4
8	E81068	WASHER, FENDER, 1/4	2
9	E83425	SCREW, PHILLIPS, 1/4-20 x 1	2
10	E83651	AXLE, 1/2 x 17.25	1
11	E83144	WHEEL, 5 INCH	2
12	E83143	CAPS, AXLE, 0.5	4
13	E83269	WASHER, SPRING, 1/2	4
14	E83145	WASHER, NYLON	8
15	E83142	WHEEL, 4 INCH	2
16	E83379	AXLE, 1/2 x 13.875	1
17	E11136	WASHER, FLAT, 3/8	13
18	E81066	WASHER, LOCK, 3/8	9
19	E81087	BOLT, HEX, 3/8-16 x 1.5"	4
20	E11721	KEY, 3/16 x 3/16 x 1	1
21	E83787	SPACER, .75 ID	1
22	E81072	BOLT, HEX, 5/16-18 x 1	1
23	E81062	WASHER, FLAT, USS, 5/16	1
24	E81067	WASHER, LOCK, 5/16	1
25	E83139	MOTOR, 1.5 HP, 3200 RPM	1
26	E85396	BOLT, HEX, 3/8-16 x 1	1
27	E83310	BEARING	2
28	E83377	SPACER, PULLEY BEARINGS	1
29	E83376	PULLEY, PAD DRIVE	1
30	E83148	PAD DRIVER, COMPLETE ASSEMBLY	1
31	E81150	CENTERING DEVICE, BIG MOUTH	1
32	E83190	SCREW, PHILLIPS PAN, ZN, 5/16-18 x 1.25	4
33	E81069	NUT, 3/8-16	1
34	E83629	BOLT, HEX, 3/8-16 x 1.25	1
35	E83150	BRACKET, PULLEY MOUNT	1
36	E81080	BOLT, HEX, 3/8-16 x .75	4
37	E83149	BELT, 2000 RPM	1
38	E81276	PULLEY, 2000 RPM	1
37B	E83140	BELT, 1600 RPM	1
38B	E83478	PULLEY, 1600 RPM	1
Not Shown	E85042	Rectifier	1
Not Shown	E85053	Carbon Brush Set of 4	1

# MOTOR COVERS

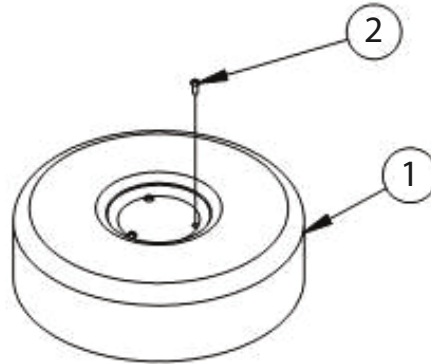

ITEM	SKU	DESCRIPTION	QTY.
1	E81141	COVER, MOTOR, 9" OD x 2.65 TALL	1
2	E81523	SCREW, PHILLIPS, 8/32 x 3/8 TRUSS HEAD	3

# ELECTRICAL

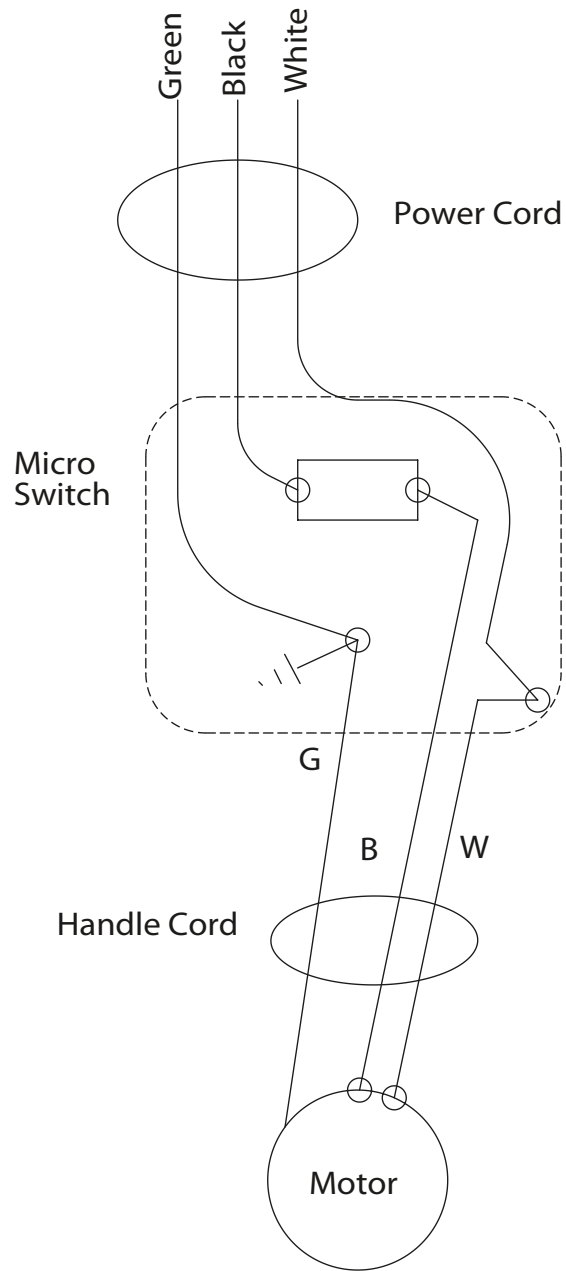

Standard Machines

Not Shown E85042 Rectifier  
Not Shown E85053 Carbon Brush Set of 4





# BETCO US WARRANTY POLICY

## 10 year coverage

Subject to the conditions stated below, Betco warrants parts and labor on rotationally molded polyethylene tanks/ housings and injection molded vacuum head assemblies to be free from defects in materials and workmanship for a period of ten years to the original purchaser.

## 3 Year Coverage

Subject to the conditions stated below, Betco warrants parts and labor on all other Betco components to be free from defects in materials and workmanship for a period of three years to the original purchaser.

## 1 Year Coverage

Subject to the conditions stated below, Betco offers a limited warranty on parts and labor on the following equipment: parts and accessories to be free from defects in materials and workmanship for a period of one year to the original purchaser.

- PowerUp™ 14 Upright Vacuum: #E29990-00
- Bac Pac Lite Vacuum: #85903-00
- FiberPRO® Floor Dryer: #85507-00
- WORKMAN™ Series Vacuums: #85024-00, #85025-00, #83012-00, #85027-00
- All Tools and Accessories
- All Battery Chargers
- All Batteries are pro-rated for 1 year

### **Allowable Travel Time Warranty Reimbursement:**

Eligible equipment: All battery and propane powered equipment products. Warranty period: 90 days from date of sale to the original purchaser. A maximum 180 mile round trip at 50 cents per mile will be allowed for warranty consideration.

### **Propane Machine Warranty:**

Kawasaki engines are warranted by Kawasaki for a period of 2 years against manufacturer defects. All other components (except wear items)\* are warranted by Betco for a period of 3 years.

**\*Wear Items exempt from Warranty consideration include but may not be limited to: power cords, transport wheels, vacuum bags, belts, squeegee blades, pad drivers, clutch plates, handle grips, filters, screens, throttle cables, brushes and carbon brushes.**

Subject to the conditions and exceptions stated in this warranty, Betco warrants the Betco products to be free from defects in material and workmanship, under normal use and service, for the periods listed under the warranty policy to the original purchaser. At any time during the warranty period, Betco will furnish replacement parts for the Betco parts to the original purchaser. Such parts will be furnished and charged including transportation costs, to the original owner through any Betco authorized Service Distributor. If the original part is returned within the warranty policy period from date of delivery for inspection by Betco and is found to be defective the owner will be credited for the cost of replacement parts plus shipping and handling. Replacement parts that have become defective through wear or abuse are not included in this warranty.

This warranty does not apply to damage or defect caused by accident, misuse, negligence, fire, or to any Betco product which has been serviced or repaired by other than an authorized Betco Service Distributor or Betco factory personnel. This warranty is void if products are used for any purpose other than that which was intended. There are no other warranties expressed or implied. In no event shall Betco be liable for incidental or consequential damages or any damage to person or property. (Please note some states do not allow the exclusion or limitations for incidental and consequential damages).

