



Electronic Service Manuals

This electronic document is provided as a service to our customers. We do not create the contents of the information contained in this document. Should you have detailed questions pertaining to the information contained in this document, you may contact Michco, or the manufacturer which provided the original information in this electronic deliverable. Michco's only part in this electronic deliverable was the electronic assembly process. By providing this manual online we are not guaranteeing parts availability.

You may contact Michco through the following methods:

Phone (517) 484-9312

2011 N. High St. -- Lansing, Michigan -- 48906

Fax: (517) 484-9836

Email: CustomerService@Michco.com

Website: www.Michco.Com

Order Parts online at:

www.Michco.Com

Directly to Parts & Service:

By Email: **CustomerService@Michco.com**

By Fax: (517) 484-9836

By Voice: (517) 484-9312

Serving the Cleaning Industry Since 1922

Notice: All copyrighted material remains property of original owners, all trademarks are property of respective owners. Manuals are subject to Manufacturer's reproduction limitations. Originals or reproductions were provided by manufacturers through a request. We make no warranty as to the correctness of information provided in this document and you assume all risk. By placing these manuals on line we are not declaring our corporation to be an manufacturer authorized dealer or provider, please check our web site for authorized manufacturers we represent.



E29975-00



FiberCAP™ 20

20" Carpet
Cleaning Machine



Operator Manual

TABLE OF CONTENTS

RECEIVING THE MACHINE.....	3
TECHNICAL SPECIFICATIONS.....	3
GENERAL SAFETY REGULATIONS.....	4
MACHINE PREPARATION.....	5
OPERATION	6 - 7
USE OF MAINTENANCE TIPS.....	8
PARTS DIAGRAMS AND LISTINGS.....	9 - 11
WARRANTY	12

RECEIVING THE MACHINE

Immediately check, when receiving the machine, that all the materials indicated on delivery documents have been received and also that the machine has not been damaged in transit. If it has been damaged, this damage must be immediately reported to the shipper and also to our customer service department. Only acting promptly in this manner will make it possible to receive missing material and to be compensated for damage.

INTRODUCTION

This is a carpet cleaning machine which, via the mechanical action of the rotating brush can clean many types of carpeted flooring.

The machine must be used only for this purpose.

Even the best machines will only work well if used correctly and kept in good working order. We therefore suggest you read this instruction booklet carefully and re-read it whenever difficulties arise while using the machine. Please contact our technical service department or your dealer if you have any questions about the machine.



Specifications

TECHNICAL DESCRIPTION	Measurement Unit	FiberCap™ 20
Working Width	Inches	20
Work Capacity	Sq. Ft. / Hour	10,000
Brush Speed	RPM	380
Brush Pressure	Lbs.	40
Weight of Machine	Lbs.	47
Power Supply	V / Hz	110 / 120 and 50 / 60
Machine Dimensions (Length/Width/Height)	Inches	21.25 / 9.25 / 42.5

GENERAL SAFETY REGULATIONS

The regulations below must be carefully followed in order to avoid harm to the operator and damage to the machine.

- Read all labels on the machine carefully. Do not cover them for any reason and replace them immediately if they become damaged.
- The machine must be used exclusively by authorized and trained personnel.
- When operating the machine be careful of other people.
- The power cable outlet must be provided with a proper ground.
- Avoid damaging the power cable by crushing, bending, cutting or stressing it.
- Whenever the power cable is damaged, immediately contact a BETCO service center.
- Do not set containers on the machine.
- Machine storage temperature is between -10°F and 130°F, never store outside under humid conditions.
- Operating conditions: room temperature between 33°F and 100°F with relative humidity between 30% to 95%.
- Only use the machine in closed areas and do not expose it directly to rain.
- Never use the machine in an explosive environment.
- Do not use the machine as a means of transport.
- Never use acidic chemicals which could damage the machine.
- Avoid running the brushes with the machine stopped; this could damage the floor.
- Never vacuum up flammable liquids.
- Never use the machine to gather dangerous powders.
- Use a powder fire extinguisher in case of fire. Do not use water.
- Do not hit against shelving or scaffolding. The operator must always be equipped with the appropriate safety device (gloves, shoes, helmet, glasses, etc.)
- If the machine does not work properly, perform routine maintenance. Otherwise, request the assistance of the BETCO technical service.
- When replacing parts ask for ORIGINAL spare parts from your Authorized BETCO Dealer and/or Retailer.
- Always turn off the machine and disconnect the power supply whenever maintenance is performed.
- Never use the machine without side guards or dust collection bins secured to the machine.
- **Never wash the machine with direct or pressurized jets of water or with corrosive substances.**
- Have your BETCO service center check the machine once a year.
- Before using the machine make sure that all doors and covers are positioned as shown in this operating and maintenance manual.
- When your BETCO machine is ready to be retired, the machine must be disposed of properly. It contains oils and electronic components. The machine was built using totally recyclable materials.
- Use only brushes furnished with the machine or those specified in the user's manual. Use of other brushes can compromise safety.

MACHINE PREPARATION

1. ASSEMBLING THE HANDLE

The handle assembly is comprised of four individual parts.

- A. Install the main cross bar onto the machine by pulling the finger pins outward on both sides and locking them into the handle mounts of the machine.
- B. Insert the open end of both handle uprights into the cross bar.
- C. Insert the open end of the round handle bar into each of the handle uprights.

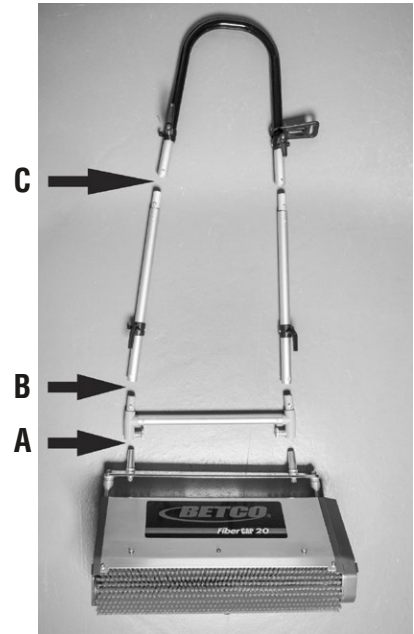

2. ASSEMBLING THE SIDE SHIELDS

The side shields must also be installed on the machine. Be sure the machine is not plugged in when performing this installation.

- A. Place the open end of the teardrop hole over the mounting pins.
- B. Slide the side shield to the right until the center spring pin locks it into place.
- C. Repeat this installation on the other side of the machine.



3. ASSEMBLING THE STORAGE TRAY

- A. Insert the metal support into the two holes on both sides of the plastic storage tray.
- B. Insert the metal axle through the single hole on both sides of the plastic storage tray.
- C. Attach the wheels to each end of the axle. The metal clip on the inside hub of the wheel should lock into place on the channel at each end of the axle.

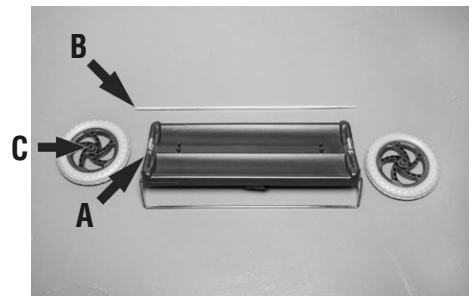

MACHINE OPERATION

1. STARTING THE MACHINE

- A. Attach the extension cord to the plug on the machine.
- B. Insert cord through strain relief holder.
- C. Plug into a grounded 110V/120V outlet.
- D. Push down the start lever on the left side of the machine. The machine will automatically start when the handle is lowered to an operating position.
- E. To turn off the machine, simply raise the handle back to a locked an upright position. The machine will automatically stop.



WARNING: Be sure to keep loose carpets and cords from passing under the machine while in operation.



2. USING THE SWEEPING FUNCTION

To use the machine as a sweeper, simply remove the side shields from the machine and install the dust collection bins.

- A. Be sure the machine is unplugged from any power source.
- B. Press the center locking pin on the side shield and slide the shield to the left. Then lift the side shield from the mounting pins on the base.
- C. Place the open end of the teardrop hole on the dust collection bin over the mounting pins.
- D. Slide the dust collection bin to the right until the center spring pin locks it into place.
- E. Repeat this installation on the other side of the machine.
- F. Now the machine can be plugged in to a power supply and used to sweep loose debris from the floor.
- G. The machine can be operated in a forward and backward motion.
- H. After use, remove the dust collection bins and empty debris.



WARNING: Be sure to keep loose carpets and cords from passing under the machine while in operation.



MACHINE OPERATION

3. ENCAPSULATION CLEANING

Follow these steps for interim encapsulation cleaning of carpet:

- A. Install the dust collection bins on the machine and sweep the carpet to remove any large and loose debris.
- B. In a spray bottle or pump sprayer dilute the Betco® FiberCap™ MP solution according to the directions on the bottle.



WARNING: Always wear gloves to protect yourself from contact with hazardous chemicals.

- C. Spray a light mist of solution onto the carpeted surface.
- D. Remove the dust collection bins on the machine and install the side shields.
- E. Turn on the machine and agitate the carpeted surface. Work in both a north-south direction as well as an east-west direction to ensure that all sides of the carpet fibers are agitated.
- F. The carpeted surface should dry in 20-30 minutes.
- G. Once dry, vacuum the carpet at the next scheduled service interval for that area.
- H. Repeat the process on a regular basis to maintain the best possible appearance of the carpet.



WARNING: Be sure to keep loose carpets and cords from passing under the machine while in operation.



USE AND MAINTENANCE TIPS

1. REMOVAL OF BRUSHES AND CLEANING THE MACHINE

After each use, the brushes should be removed and cleaned. The underside of the machine should be cleaned as well.

- A. Disconnect the power supply from the machine.
- B. Lay the machine on the floor and pull the axle out from the center of the brush on the right side of the machine.
- C. Clean the brushes with jet-powered water.
- D. Clean the underside of the machine with a hand brush or cloth.
- E. To install the brushes, simply slide the axle back through the center core of the brush until it locks into place on the left side of the machine.
- F. The brushes should be replaced once the overall bristle-to-bristle diameter is less than 2.75”.

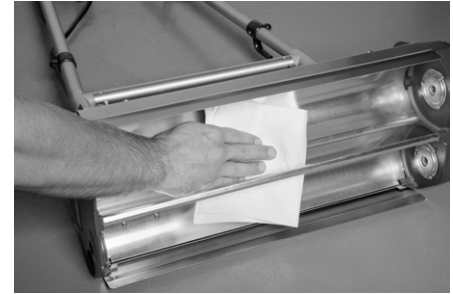

WARNING: Carry out all maintenance operations with the power cord unplugged from the wall outlet.

2. MOTOR SAFETY SWITCH

- A. The safety switch automatically cuts off the electricity when the motor overloads.
- B. Should this happen, disconnect the power supply, wait 30 seconds, and press the button inwards to reset the safety switch.
- C. Then reconnect the power supply and continue working.



3. TANDEM USE

Two machines can be connected together to double the productivity of carpet cleaning.

- A. Position two machines side-by-side facing in the same direction.
- B. Completely remove the handles from both machines.
- C. Install the tandem mounting bar on the handle posts for both machines.
- D. Install one of the operator handles to the tandem mounting bar.
- E. Plug the short cord from one machine to the open electrical socket on the rear of the second machine.
- F. Connect the power cord from the second machine to the extension cord.
- G. Press the activation lever on both machines to lower the handle and begin use.

PARTS DIAGRAM

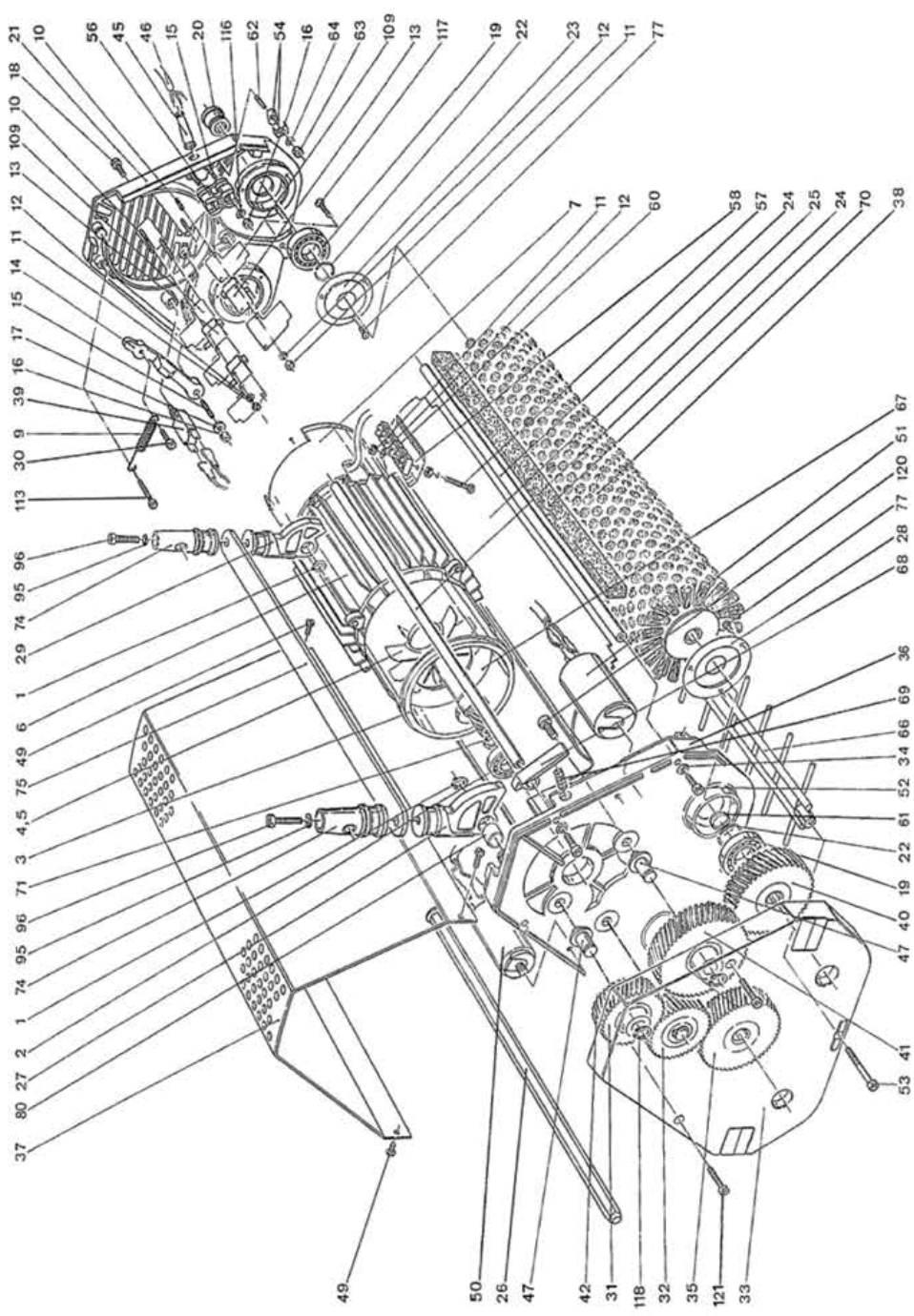

PARTS LISTING

Item #	Part #	Description	Item #	Part #	Description
1	E84600	Snapring	53	E84641	Screw, M5 x 45
2	E84607	Bearing	54	E84642	Clamp Strip
3	E84601	Motor Spacer	56	E84644	Cable Clamp
4	E84602	Roll Pin	57	E84645	Screw, M3 x 16
5	E84603	Motor Fan	58	E84646	Wire Fixing Plate
6	E84608	Motor, 1.0 HP	60	E84647	Wire Terminal
7	E84604	Motor Spacer	61	E84648	V-Ring
9	E84610	Spring	62	E84649	Worm Screw
10	E84605	Worm Screw, M3 x 35	63	E84688	Nut, M4
11	E84686	Nut, M3	64	E84650	Lock Washer, M4
12	E84687	Split Washer, M3	68	E84652	Handle Stop
13	E84685	Rectifier	69	E84653	Spring, Handle Stop
14	E84611	Switch Lever	70	E84651	Plastic Strip
15	E84606	Worm Screw, M5 x 25	71	E84654	Snapring
16	E82317	Nut, M5	74	E84655	Handle Connector
17	E83879	Washer, M5	75	E84656	Flat Bar
18	E84612	Socket Screw, M5 x 12	77	E84657	Screw, M3 x 5
19	E84622	Bearing	78	E84658	Locking Pin
20	E84623	Flange	96	E84663	Screw, M6 x 30
22	E84613	Retaining Ring	113	E84664	Screw, M6 x 16
23	E84614	Protective Plate	116	E84665	Lock Washer
24	E84615	Motor Stud	117	E84666	Screw, M5 x 12
25	E84616	Brush Shield	120	E84668	Screw, M6 x 16
26	E84617	Brush Axle	121	E84669	Screw, M5 x 12
27	E84618	Handle Connector, Right	126	E84677	Cord Wrap Hook
28	E84619	Protective Plate	151	E84673	Bolt For Dust Bin
29	E84620	Handle Connector, Left	162	E84676	Wiring Cover
30	E84621	Screw, M6 x 16	165	E84680	Wiring Cover
31	E84624	Gear, 48 Right	166	E84681	Rubber Bumper
32	E84625	Gear, 48 Left	167	E84682	Wiring Cover
33	E84626	Gear Cover			
34	E84627	Lock Washer, M5			
35	E84631	Gear, 66 Right			
37	E84628	Motor Cover			
38A	E84634	Brush, General Purpose 20" Cylindrical (Carpet)			
38B	E84633	Brush, Medium Duty 20" Cylindrical (Hard Surface)			
39	E84632	Circuit Breaker			
40	E84635	Gear, 66 Left			
41	E84636	Gear, 73 Right			
45	E84629	Grommet			
46	E84683	Extension Cord			
47	E84637	Bearing Stud			
49	E84630	Screw			
50	E84638	Run Capacitor, 22 MFD			
51	E84639	Start Capacitor, 145 MFD			
52	E84640	Screw, Socket Head M5 x 12			

PARTS DIAGRAM & LISTING

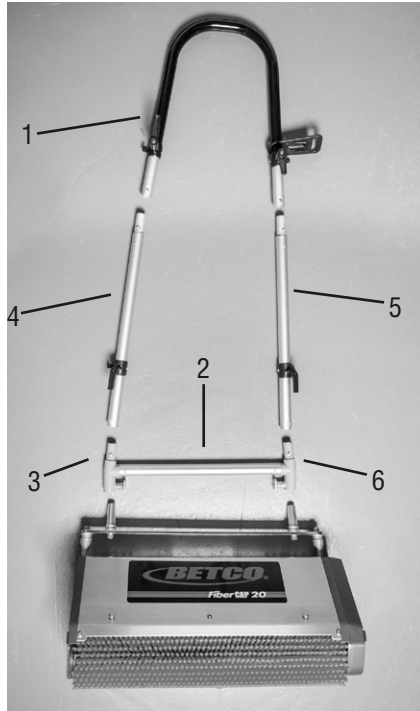

Item #	Part #	Description
1	E84659	Handle Bar, Upper Section
2	E84660	Handle Base Cross Bar
3	E84661	Handle T-Mount, Left
4	E84670	Handle Tube, Lower Left
5	E84671	Handle Tube, Lower Right
6	E84672	Handle T-Mount, Right

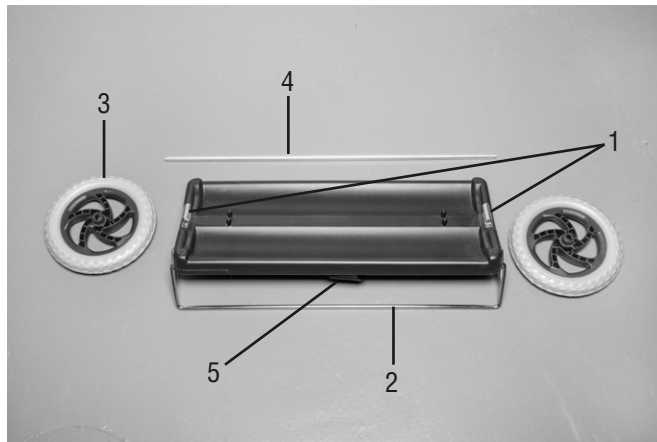

Item #	Part #	Description
1	E84643	Trolley Spring Tab
2	E84674	Trolley Support
3	E84678	Trolley Wheel
4	E84675	Trolley Axle
5	E84679	Trolley Velcro Belt

BETCO US WARRANTY POLICY

10 year coverage

Subject to the conditions stated below, Betco warrants parts and labor on rotationally molded polyethylene tanks/ housings and injection molded vacuum head assemblies to be free from defects in materials and workmanship for a period of ten years to the original purchaser.

3 Year Coverage

Subject to the conditions stated below, Betco warrants parts and labor on all other Betco components to be free from defects in materials and workmanship for a period of three years to the original purchaser.

1 Year Coverage

Subject to the conditions stated below, Betco offers a limited warranty on parts and labor on the following equipment: parts and accessories to be free from defects in materials and workmanship for a period of one year to the original purchaser.

- PowerUp™ 14 Upright Vacuum: #E29990-00
- Bac Pac Lite Vacuum: #85903-00
- FiberPRO® Floor Dryer: #85507-00
- WORKMAN™ Series Vacuums: #85024-00, #85025-00, #83012-00, #85027-00
- All Tools and Accessories
- All Battery Chargers
- All Batteries are pro-rated for 1 year

Allowable Travel Time Warranty Reimbursement:

Eligible equipment: All battery and propane powered equipment products. Warranty period: 90 days from date of sale to the original purchaser. A maximum 180 mile round trip at 50 cents per mile will be allowed for warranty consideration.

Propane Machine Warranty:

Kawasaki engines are warranted by Kawasaki for a period of 2 years against manufacturer defects. All other components (except wear items)* are warranted by Betco for a period of 3 years.

***Wear Items exempt from Warranty consideration include but may not be limited to: power cords, transport wheels, vacuum bags, belts, squeegee blades, pad drivers, clutch plates, handle grips, filters, screens, throttle cables, brushes and carbon brushes.**

Subject to the conditions and exceptions stated in this warranty, Betco warrants the Betco products to be free from defects in material and workmanship, under normal use and service, for the periods listed under the warranty policy to the original purchaser. At any time during the warranty period, Betco will furnish replacement parts for the Betco parts to the original purchaser. Such parts will be furnished and charged including transportation costs, to the original owner through any Betco authorized Service Distributor. If the original part is returned within the warranty policy period from date of delivery for inspection by Betco and is found to be defective the owner will be credited for the cost of replacement parts plus shipping and handling. Replacement parts that have become defective through wear or abuse are not included in this warranty.

This warranty does not apply to damage or defect caused by accident, misuse, negligence, fire, or to any Betco product which has been serviced or repaired by other than an authorized Betco Service Distributor or Betco factory personnel. This warranty is void if products are used for any purpose other than that which was intended. There are no other warranties expressed or implied. In no event shall Betco be liable for incidental or consequential damages or any damage to person or property. (Please note some states do not allow the exclusion or limitations for incidental and consequential damages).

