



## **Electronic Service Manuals**

This electronic document is provided as a service to our customers. We do not create the contents of the information contained in this document. Should you have detailed questions pertaining to the information contained in this document, you may contact Michco, or the manufacturer which provided the original information in this electronic deliverable. Michco's only part in this electronic deliverable was the electronic assembly process. By providing this manual online we are not guaranteeing parts availability.

You may contact Michco through the following methods:

**Phone (517) 484-9312**

2011 N. High St. -- Lansing, Michigan -- 48906

Fax: (517) 484-9836

Email: [CustomerService@Michco.com](mailto:CustomerService@Michco.com)

Website: [www.Michco.Com](http://www.Michco.Com)

Order Parts online at:

**[www.Michco.Com](http://www.Michco.Com)**

Directly to Parts & Service:

By Email: **[CustomerService@Michco.com](mailto:CustomerService@Michco.com)**

By Fax: (517) 484-9836

By Voice: (517) 484-9312

**Serving the Cleaning Industry Since 1922**

Notice: All copyrighted material remains property of original owners, all trademarks are property of respective owners. Manuals are subject to Manufacturer's reproduction limitations. Originals or reproductions were provided by manufacturers through a request. We make no warranty as to the correctness of information provided in this document and you assume all risk. By placing these manuals on line we are not declaring our corporation to be an manufacturer authorized dealer or provider, please check our web site for authorized manufacturers we represent.

# WS17

**Chemicals**  
**Equipment**  
**Programs**  
**Process**



## Betco Watchman® 17" Automatic Scrubber

The Betco Watchman® series of automatic scrubbers bring a new dimension to cleaning maintenance. The Watchman® 17 offers a compact size for easy maneuvering making it perfect for small to medium size facilities with tight areas. Its simple design and controls make operation easy and reduce operator training. Unique features include hands free pad driver installation and a removable recovery tank, no tools required. A heavy-duty squeegee assembly provides maximum water recovery.

### Applications

- General cleaning
- Heavy duty cleaning

### Features

- Simple design for easy operation
- Hands free pad driver installation
- Heavy duty squeegee assembly
- Removable recovery tank for easy transport and serviceability
- Durable rotationally molded polyethylene construction

### Warranty

Tank: 10 Year

Other components: 3 Year\*

\*Please refer to Betco Equipment Price/Product Guide for complete equipment warranty information.

### Specifications

Cleaning path .....	17"
Pad Driver .....	(1) 17"
Brush motor .....	(1) 0.5 hp
Brush pressure .....	50 lbs.
Brush speed .....	275 RPM
Vacuum motor .....	0.5 hp 2-stage
Noise level .....	65 dB
Water lift .....	48"
Solution control .....	Gravity feed - adjustable
Solution tank .....	10 gallon
Recovery tank .....	11 gallon
Weight .....	155 lbs.
Length .....	43"
Width .....	18" w/o squeegee
Width .....	26" w/squeegee
Height .....	38"
Volts .....	24 volt system
Batteries .....	(2) 12 volt
Run time .....	Approximately 3.5 hours
Tires .....	Heavy duty non-marking
Productivity .....	15,000 sq. ft./hour

### Available In

WS17 Watchman® - 17": Item #86001-00

Literature Item #86001-92

**SUMMARY**

<b>ON CONSIGNMENT OF THE MACHINE .....</b>	<b>24</b>
<b>FOREWORD .....</b>	<b>24</b>
<b>TECHNICAL DESCRIPTION .....</b>	<b>24</b>
<b>SYMBOLGY USED ON THE MACHINE .....</b>	<b>25</b>
<b>SYMBOLGY USED IN THE MANUAL .....</b>	<b>26</b>
<b>MACHINE PREPARATION .....</b>	<b>27</b>
MOVING THE PACKED MACHINE .....	27
HOW TO UNPACK THE MACHINE.....	27
INSTALLING THE BATTERY.....	28
CONNECTING THE BATTERY CHARGER.....	28
BATTERY RECHARGING.....	29
CONNECTING BATTERY CONNECTOR.....	29
BATTERY CHARGE LEVEL GAUGE.....	30
INSTALLING THE SQUEEGEE .....	30
SQUEEGEE HEIGHT ADJUSTING .....	30
SQUEEGEE INCLINATION ADJUSTING .....	30
INSTALLING THE SPLASH-GUARD .....	31
INSTALLING THE BRUSH.....	31
RECOVERY TANK .....	32
SOLUTION TANK.....	32
<b>GENERAL SECURITY RULES .....</b>	<b>33</b>
<b>WORK .....</b>	<b>34</b>
WORK PREPARATION.....	34
OVERFLOW DEVICE .....	35
TRACTION.....	35
<b>UPON COMPLETION OF WORK .....</b>	<b>36</b>
<b>DAILY MAINTENANCE.....</b>	<b>37</b>
RECOVERY TANK CLEANING .....	37
SUCTION FILTER CLEANING.....	37
SQUEEGEE CLEANING .....	37
REAR SQUEEGEE RUBBERS REPLACEMENT .....	38
BRUSHES DISASSEMBLY .....	38
<b>WEEKLY MAINTENANCE .....</b>	<b>39</b>
SQUEEGEE PIPE CLEANING .....	39
SOLUTION TANK CLEANING .....	39
<b>WORKING CONTROL .....</b>	<b>40</b>
INSUFFICIENT WATER TO THE BRUSHES.....	40
THE MACHINE DOES NOT CLEAN PROPERLY .....	40
THE SQUEEGEE DOES NOT DRY PERFECTLY .....	40
FOAM OVER-FORMATION.....	40
<b>CHOICE AND USE OF BRUSHES .....</b>	<b>41</b>

### On consignment of the machine

When the machine is consigned to the customer, an immediate check must be performed to ensure all the material mentioned in the shipping documents have been received and moreover to find out that the machine has not suffered damage during transportation. If damage has occurred, get the shipping agent to verify immediately the amount and nature of the damage suffered and at the same time inform our claim department. It is only by prompt action of this type that compensation for damage may be successfully claimed.

### Foreword

This is a sweep-scrubbing machine which, using the mechanic abrasive action of two rotary brushes and the chemical action of a solution water-detergent, is able to clean any type of floor, picking up during its advance movement, the removed dirt and the detergent solution which has not been absorbed from the floor.

**The machine must be used only for such purpose.** We would impress upon you that any machine will function efficiently and operate successfully, only if used correctly and maintained in fully efficient working order. We therefore suggest you to read this instruction booklet carefully and re-read it whenever difficulties arise in the course of machine use. Our Service Department is at your disposal for all such advice and servicing as may prove necessary.



TECHNICAL DESCRIPTION	U/M	ABILA 42	ABILA 52
Cleaning width	mm	400	500
Squeegee width	mm	660	660
Working capacity, up to	sqm/h	1400	1750
Brushes diameter	mm	2x210	2x255
Brushes rpm	rpm	340	275
Brushes pressure	kg	20 max	22 max
Brushes motor	W	400	400
Drive type		Semi-aut.	Semi-aut.
Movement speed	km/h	3.5	3.5
Max gradient		2%	2%
Suction motor	W	370	370
Suction vacuum	mbar	100	100
Solution tank	l	36	36
Recovery tank	l	40	40
Machine length	mm	1060	1100
Machine height	mm	960	960
Machine width (without squeegee)	mm	455	565
Batteries (voltage)	V	24	24
Batteries (capacity)	Ah	50	50
Batteries (compartment)	mm	360x330x250	360x330x250
Batteries weight	kg	40	40
Machine weight (empty and without batteries)	kg	70	72
Acoustic radiation pressure level (IEC 704/1)	db (A)	<65	<65
Vibration level	m/sqs	1.00	1.00

**SYMBOLGY USED ON THE MACHINE**

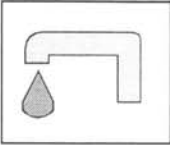

Cock symbol  
Indicates the cock lever  
Indicates the cock open signal lamp

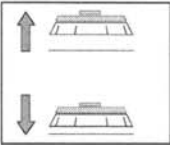

Squeegee base lift/lower symbol  
Indicates the base lift lever

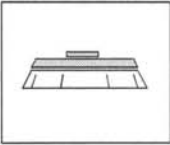

Brush symbol  
Indicates the brush motor switch

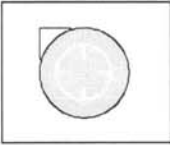

Suction motor symbol  
Indicates the suction motor switch

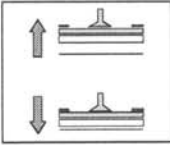

Squeegee lift/lower symbol  
Indicates the squeegee lift lever

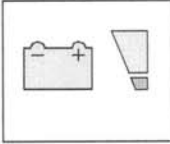

Battery charge level symbol

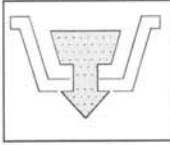

Indicated the recovery tank outlet pipe

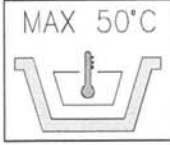

Indicates the detergent solution maximum temperature  
It is placed by the solution tank inlet mouth.



Hooking symbol  
Indicates anchoring points and loading direction.

**SYMBOLY USED ON THE MACHINE**

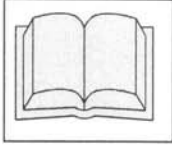

Open book symbol  
Indicates to the operator to read the manual before using the machine.

**SYMBOLY USED IN THE MANUAL**



Warning symbol  
Carefully read the sections marked with this symbol, for the security of both the operator and the machine.

## MACHINE PREPARATION

### MOVING THE PACKED MACHINE

The machine is contained in specific packing with a platform so that a forklift can move it. No more than two packing crates can be stacked on each other

The total weight is : -Abila 42: 136 Kg  
-Abila 52: 138 Kg

Packing dimensions are the following:

- A** : 1260 mm
- B** : 660 mm
- C** : 1230 mm

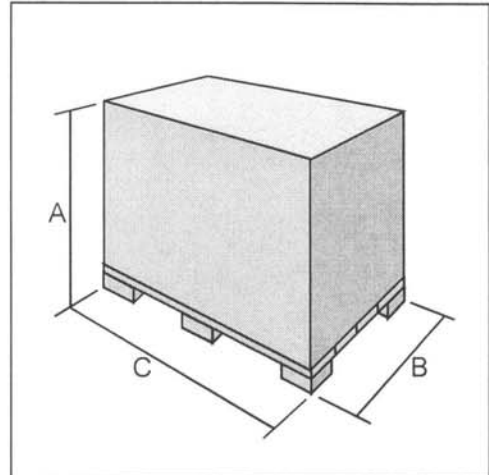

### HOW TO UNPACK THE MACHINE

1. Remove outer packing.
2. The machine is strapped to its platform.
3. Remove the strap.

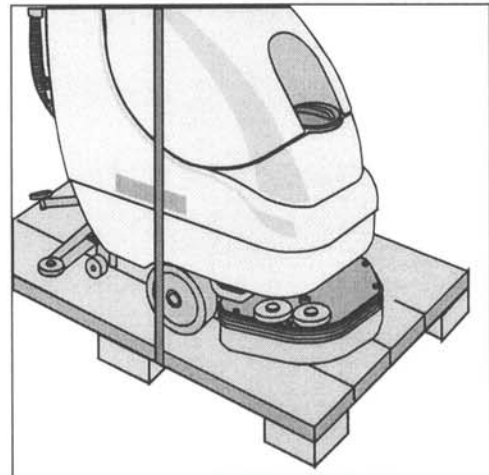

4. Use a ramp to lower the machine off the platform, pushing it backward in reverse. Avoid violent blows against the base.
5. Keep the packing platform since it may become necessary to transport the machine again.

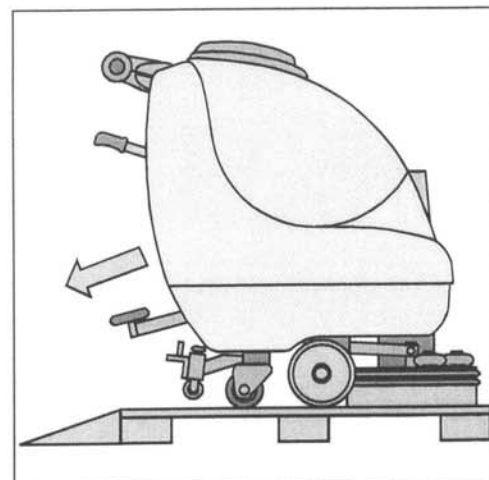

## MACHINE PREPARATION

### INSTALLING THE BATTERY

Battery must be housed in the battery compartment below the recovery tank, and must be handled using special hoisting equipment with suitable grasping systems and designed to support the battery weight.

The battery must also conform to the requirements given in CEI 21-5 standards.



**WARNING:** Strictly comply with all the instructions given by the battery manufacturer or retailer regarding battery maintenance and daily recharging. Specialists must carry out all installation and maintenance procedures.

Battery installation procedure:

1. Open the recovery tank lid forward.
2. Disconnect the squeegee cable (1) from the recovery tank.
3. Remove the suction cap (2) by turning it in anticlockwise sense.
4. Disconnect the "recovery tank " outlet pipe from the proper hook.
5. Remove the recovery tank.

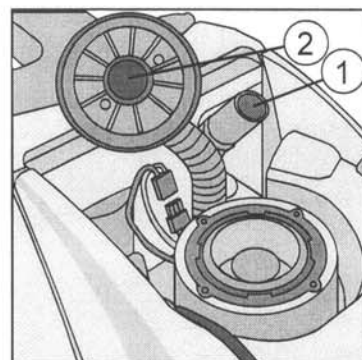

6. Place the battery.
7. Connect the battery connector (2) to the machine connector (1).
8. Reassemble everything.

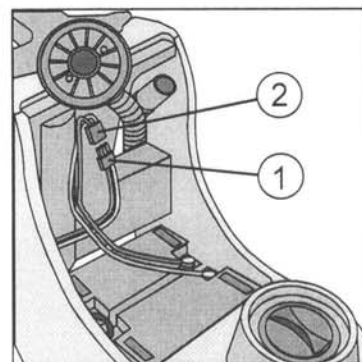

### CONNECTING THE BATTERY CHARGER

The battery connector (2), in which the battery charger connector is to be inserted, is placed under the recovery tank cap. The battery charger connector is delivered inside the bag containing this instructions booklet, and must be fitted to the battery charger cables according to instructions.



**WARNING:** this procedure is to be carried out by specialists. A wrong or defective connection of the cables to the connectors can cause serious damages persons and things.

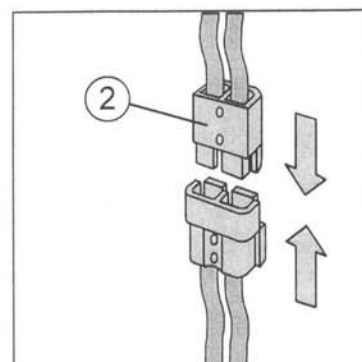

## MACHINE PREPARATION

### BATTERY RECHARGING

Make sure that the battery charger is suitable to the installed battery, both in capacity and in type (lead/acid or GEL and equivalent).



**WARNING:** never charge a GEL battery with an unsuitable battery charger. Strictly follow the instructions provided by the battery and battery charger manufacturer.

In order to avoid permanent damages to the battery, they should never be totally discharged. To do this, they should be recharged within a few minutes after the battery discharge signal starts to flash.

**NOTE:** Never left the battery completely discharged, not even if the machine is not being used.



**WARNING:** For the daily recharging of the battery it is necessary to strictly follow the instructions provided by the manufacturer or dealer. Specialists must carry out all installing and maintenance procedures. Danger of exhalation of gas and emission of corroding substances. Danger of fire: keep away from flames.

### CONNECTING BATTERY CONNECTOR

The battery connector (2) must be connected to the machine connector (1).

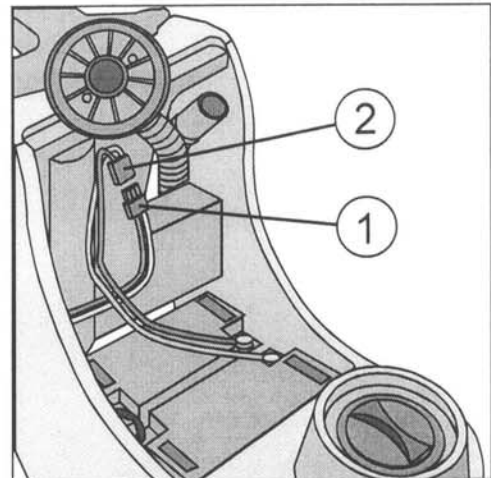

## MACHINE PREPARATION

### BATTERY CHARGE LEVEL GAUGE

The batteries' indicator is digital with 4 fixed positions and a blinking one. The numbers, which appear on the display, show the approximate charge level.

**4** = maximum charge, **3** = charge 3/4, **2** = charge 2/4, **1** = charge 1/4,

**0** = (blinking) discharged batteries)



**WARNING:** Some seconds after that "0" blinks, the brush motor automatically switches off. Anyways, the machine can finish to dry before recharging the batteries.

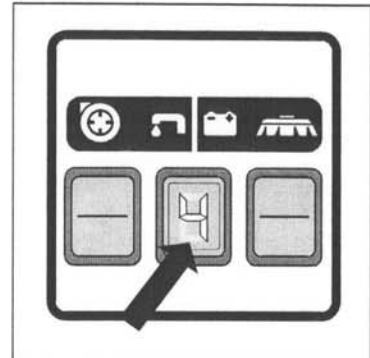

### INSTALLING THE SQUEEGEE

The squeegee is supplied separately from the machine, due to packing reasons. It must be installed as shown in the picture, threading the retaining pin into the squeegee column. Put the squeegee suction tube into its sleeve.

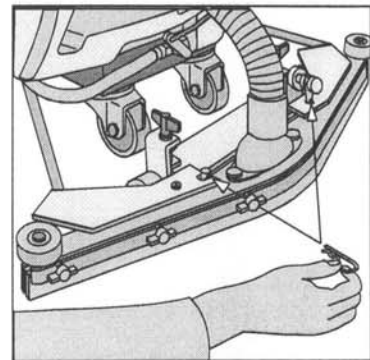

### SQUEEGEE HEIGHT ADJUSTING

The squeegee height is to be regulated according to rubbers wearing. To adjust this: rotate the wing nuts (1) anticlockwise to lift the squeegee and clockwise to lower it.

Note: The right and left wheels must undergo the same regulation, to allow the squeegee to work parallel to the ground.

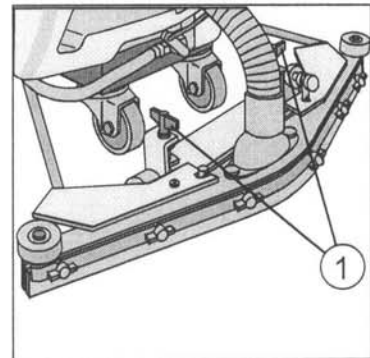

### SQUEEGEE INCLINATION ADJUSTING

During the running, the back rubber is to be lightly inclined backwards (about 5 mm, on its whole length). Should it be necessary, you can increase the rubber central inclination by inclining backwards the squeegee body, turning the regulator anticlockwise (1). To increase the bending of the rubber on the squeegee sides, turn the register clockwise. Once the regulation is finished, lock the block nut.

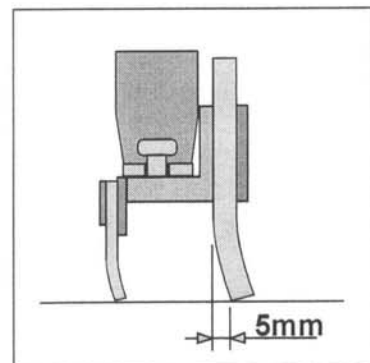

## MACHINE PREPARATION

### INSTALLING THE SPLASH-GUARD

The splashguard is supplied separately from the machine, for packing reasons, and is to be installed as shown in the picture.

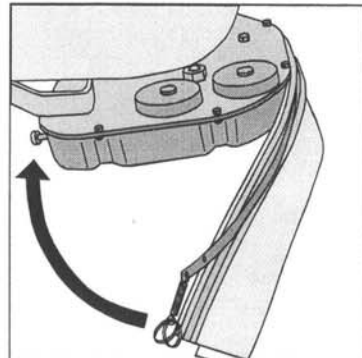

### INSTALLING THE BRUSH

1. Lift the brush base by acting on the pedal.

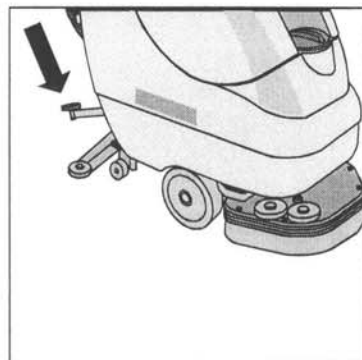

2. Keeping the base lifted, thread the brushes on their seat on the hole under the base, turning them until the three buttons enter the holes in the plate. Snap-shut the button on the coupling spring to block it.  
The picture shows the rotation direction just for the right brush: for the left one, turn on the opposite direction.

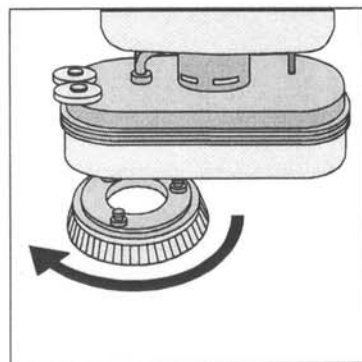

We recommend to exchange daily the right brush with the left brush and vice versa. If the brushes are not new, and their bristles are twisted, you would better reassemble them in their original position, to avoid any overloads on the motor or excessive vibrations.

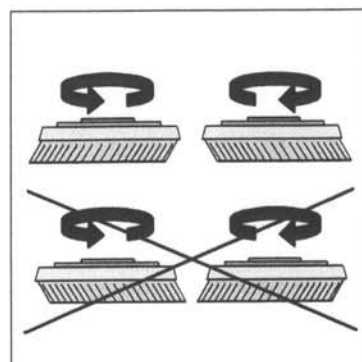

## MACHINE PREPARATION

### RECOVERY TANK

Open the lid and check that plug (2) is properly anchored (it must not pull out when it is lifted, otherwise turn it clockwise), and that suction tube (1) is inserted in its seat, in the back of the machine, and closed.

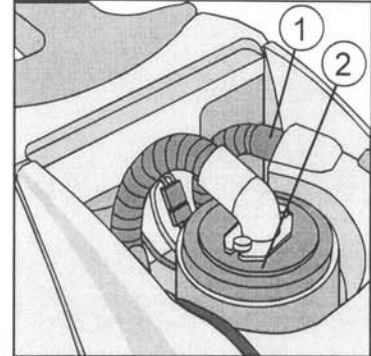

### SOLUTION TANK

Fill the solution tank with clean water at a temperature not in excess of 50°C. Add liquid detergent in the amounts and using the procedures recommended by the detergent manufacturer. Use only a minimal percentage of detergent to prevent formation of an excessive quantity of foam, as this could damage the suction motor. Close the cap.



**WARNING:** always use low-foam detergent. Introduce a small amount of anti-foam detergent in the recovery tank before start working, to be sure to prevent foam formation. **Never use pure acids.**

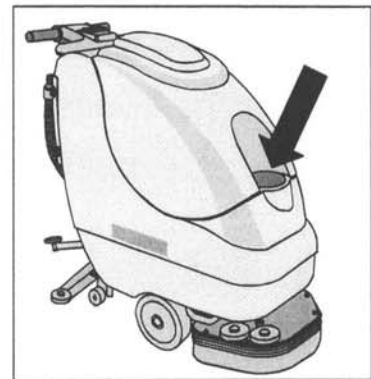

## GENERAL SECURITY RULES

**Please carefully follow the listed below rules in order to avoid harm to the operator and damage to the machine:**

- Read the labels on the machine carefully. Never cover them for any reason and always immediately replace them if they are damaged
- The machine is to be used by authorised and trained personnel only
- Pay attention to other people and particularly to children while the machine is working
- Never mix different types of detergents: this could generate noxious gases
- Never sets containers of liquids on the machine
- Machine storage temperature must be between -25°C and +55°C
- Operating conditions: room temperature between 0°C and +40°C with respective humidity between 30 and 95%
- Never use the machine in an explosive environment
- Never use the machine to transport goods
- Never use acid solutions, which could damage people or the machine
- Avoid running the brushes with the machine stopped: this could damage the floor
- Never aspirate flammable liquids
- This appliance is not suitable for picking up hazardous dust
- Use a powder fire extinguisher in case of fire. Do not use water
- Do not hit against shelving or scaffolding when there is a danger of falling objects
- Suit operating speed to traction conditions
- ATTENTION: Never exceed the maximum slope limits: this could cause instability
- The machine must perform washing and drying operations simultaneously. Any other operations must be done in zones where the presence of unauthorised persons is prohibited. Signal wet floor with suitable signs
- Whenever the machine has operating troubles check to make sure these are not due to insufficient ordinary maintenance. Should not it be the case, enquire with your nearest **COMAC** assistance centre
- When replacing machine parts, always ask for ORIGINAL spare parts from your Authorized Agent and/or Retailer
- Use only original **COMAC** brushes indicated in the paragraph "CHOICE AND USE OF BRUSHES"
- Always cut out the electric power supply to the machine whenever maintenance is performed
- ATTENTION: Restore all electrical connections after any maintenance operation
- Never remove guards that require tools for removal
- Never wash the machine with direct pressurised jets of water or with corrosive substances
- Have your nearest **COMAC** service centre checks the machine every 200 operating hours
- To avoid encrustations on the solution tank filter, do not fill it with the detergent solutions many hours before using the machine
- Before using the machine, make sure that all the doors and coverings are positioned as shown in this use and maintenance booklet
- Check that the recovery tank is empty before removing it
- Carry off consumption materials according to the laws in force
- When, after years of precious work your **COMAC** machine will be ready to be "pensioned", organise the carrying off of its composing materials, in particular oils, batteries and electronics components. Please remember that the machine has been built using totally recyclable materials

## WORK

### WORK PREPARATION

1. Connect the connector (1) to the battery.

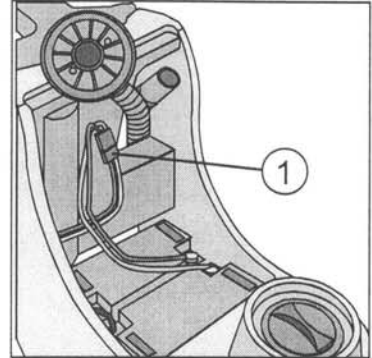

2. Press the brush switch (2)
3. Press the suction switch (3)

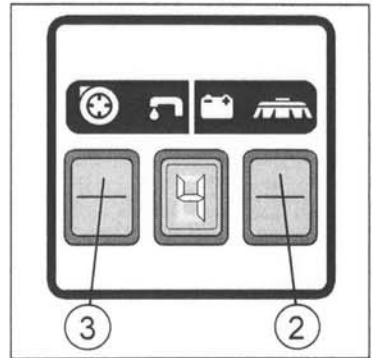

4. Act on the cock lever (4) to adjust the detergent solution quantity: it should be enough to regularly wet the floor but not as much as to flow out the splashguard. Please note the right solution quantity depends on floor type, on dirt importance and on speed.
5. Release the pedal and let the base lower.
6. Lower the squeegee acting on the lever (5).

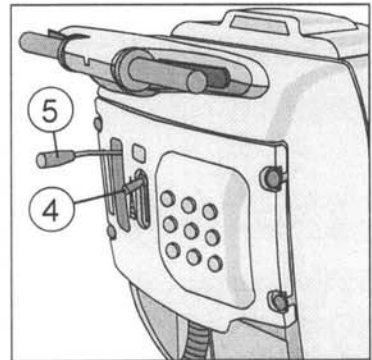

7. Acting on the deadman lever (6) the brushes start turning and the squeegee starts drawing in.
8. During the first few metres check that the amount of water is sufficient and that the squeegee dries the floor perfectly.

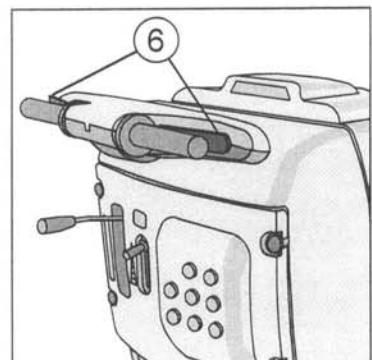

**WORK**

**OVERFLOW DEVICE**

The machine is supplied with float that trips whenever the recovery tank is full, closing the suction tube. In this case you should empty the recovery tank by removing the outlet pipe cap.



**WARNING:** Always wear gloves during this procedure, to avoid any contact with dangerous substances.



**TRACTION**

The brush obtains the traction of this machine: its inclination while working allows dragging the machine along.



**WARNING:** While going into reverse, even briefly, make sure that the squeegee is lifted.

## UPON COMPLETION OF WORK

At the end of the work, and before performing any type of maintenance:

1. Close the cock by lever (1).
2. Raise base by pedal.
3. Raise squeegee by lever (2)

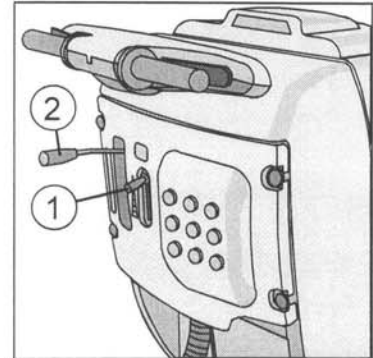

4. Turn off the brush switch (3).
5. Turn off suction motor switch (4).



**WARNING!** If after having switched off the brush switch (3) the display of the battery indicator remains on, this means that, the solution cock is open. Close the water cock through the lever (1) in order to avoid leakage of the detergent solution.

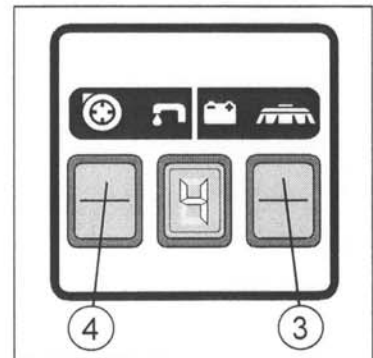

6. Move the machine to the water disposal point.

7. Hold the pipe placed on the back of the machine.
8. Remove the outlet cap and empty the tank.



**WARNING:** Always wear gloves during this procedure to avoid any contact with dangerous substances.

9. Disassembly the brush and clean it by a jet of water (for the disassembly of the brush see the following "DISASSEMBLY OF THE BRUSH")



## DAILY MAINTENANCE

### RECOVERY TANK CLEANING

1. Hold the recovery tank outlet pipe.
2. Remove the outlet cap and empty the tank.



**WARNING:** Always wear gloves during this procedure, to avoid any contact with dangerous substances.



3. Lift the recovery tank lid.
4. Remove the suction cap (1) turning it anticlockwise.
5. Remove the filter and its protection.
6. Rinse the tank with a jet of water.

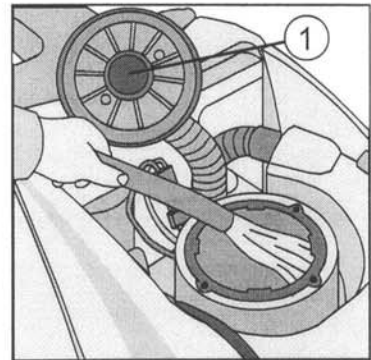

### SUCTION FILTER CLEANING

1. Lift the lid.
2. Remove the suction cap turning in anticlockwise.
3. Remove the filter.
4. Clean the filter walls and bottom by a jet of water.
5. Carry out the cleaning procedures very carefully.
6. Reassemble everything.

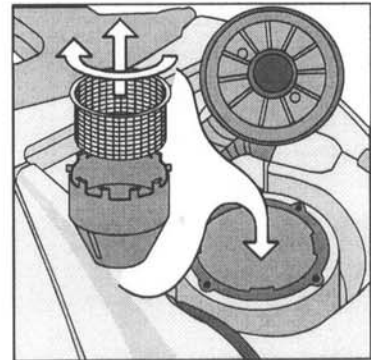

### SQUEEGEE CLEANING

The squeegee must be in perfect working condition to achieve a good drying process. Proceed as follows to clean it:

1. Remove the pipe from the squeegee.
2. Loosen the knobs (1) shown in picture.
3. Remove the mouth and clean it.
4. Carefully clean the inside of the squeegee.
5. Carefully clean the squeegee rubbers.
6. Reassemble everything.

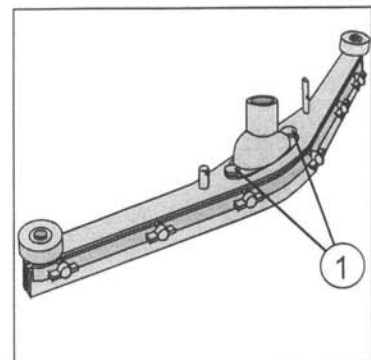

## DAILY MAINTENANCE

### REAR SQUEEGEE RUBBERS REPLACEMENT

Check the squeegee rubbers wear and replace them if necessary.  
Proceed as follows

1. Unthread the squeegee pipe from sleeve.
2. Remove the pin from column.
3. Remove the squeegee from its support.
4. Loosen the wing nuts (1) blocking the rubber blades and take them off.
5. Replace the rubbers

To reassemble the squeegee repeat the above-mentioned operations.

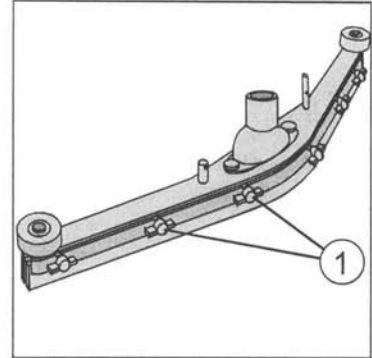

### BRUSHES DISASSEMBLY

6. Push lever down to raise the base.
7. Turn key to OFF and remove it from the control panel (1)



**WARNING:** Removing the brushes with power on may cause injury to the hands.

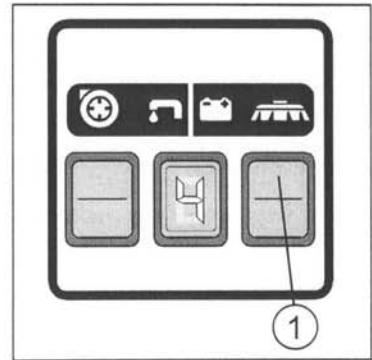

8. Rotate the brush, with base raised, until it exits from the brush-bearing plate as shown in the picture. The picture shows the direction of rotation for releasing the right brush. Rotate in opposite direction for the left brush.



**WARNING:** make sure that no persons or object are nearby the brush during this operation.

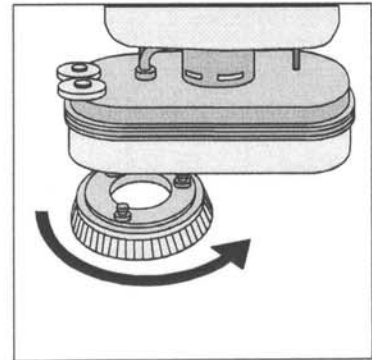

**WEEKLY MAINTENANCE**

**SQUEEGEE PIPE CLEANING**

Weekly, or whenever the suction is insufficient, it is necessary to check that the squeegee pipe is not obstructed. Should it be the case, proceed as follows to clean it:

1. Unthread the pipe from the squeegee sleeve.
2. Unthread the other end from the recovery tank.
3. Wash the inside of pipe by a jet of water, from the side it is plug to the tank.
4. To reassemble the pipe repeat the above-mentioned operations.



**WARNING:** Do not wash the pipe connecting the aspirator to the suction cap.

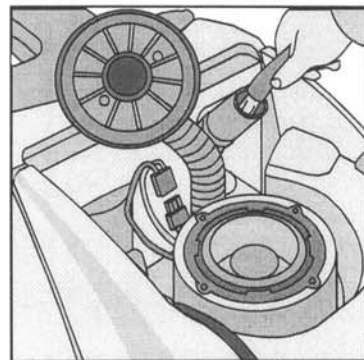

**SOLUTION TANK CLEANING**

1. Remove the cap from the solution tank.
2. Rinse with a jet of water.
3. Remove the outlet cap (1) and empty the tank



**WARNING:** Always wear gloves during this procedure, to avoid any contact with dangerous substances.

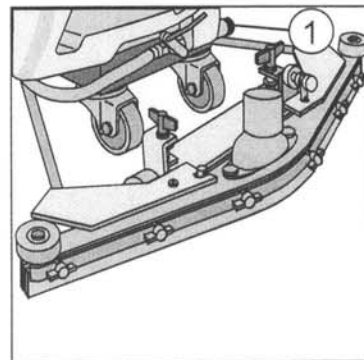

## WORKING CONTROL

### INSUFFICIENT WATER TO THE BRUSHES

1. Check that the cock (1) is open.
2. Check that there is water in the solution tank.

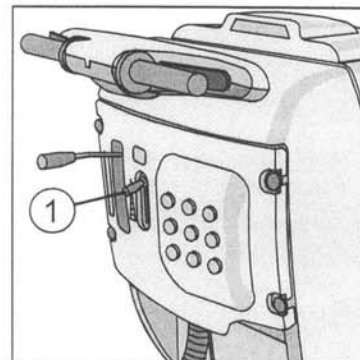

### THE MACHINE DOES NOT CLEAN PROPERLY

1. Check the brushes wear and replace them if necessary (the brushes must be replaced when bristles are 15 mm high).  
To replace brushes see "BRUSHES DISASSEMBLY" and "BRUSH ASSEMBLY".
2. Use another type of brush rather than the standard brush. We recommend, for cleaning exceptionally difficult dirt floors, the use of special brushes, supplied on request and according to your specific needs (see "CHOICE AND USE OF BRUSHES").

### THE SQUEEGEE DOES NOT DRY PERFECTLY

1. Check that the squeegee rubbers are clean
2. Adjust the squeegee inclination (see "SQUEEGEE" in "PREPARING THE MACHINE")
3. Check that the suction pipe is correctly housed in its seat on the recovery tank.
4. Remove the whole suction unit and clean it.
5. Replace the rubbers if worn.
6. Check that the suction motor switch is turn on.
7. Check the wheels regulation.

### FOAM OVER-FORMATION

Check that low-foam detergent is used. Add, if necessary, a small quantity of anti-foam liquid to recovery tank.

Please remember that more foam is generated when the floor to be cleaned it is not very dirty. In this case use a more diluted detergent solution.

## CHOICE AND USE OF BRUSHES

### POLYPROPYLENE BRUSH (PPL)

It is used on all floor types and offers good resistance to wear and to hot water (not over 60°C). PPL is not hygroscopic, then preserves its characteristics even when working on wet floors.

### NYLON BRUSH

It is used on all floor types and offers excellent resistance to wear and to hot water (60°C and over). Nylon is hygroscopic and tends, over a period of time, to lose its characteristics when working on wet floors.

### TYNEX BRUSH

This brush bristles are impregnated with highly aggressive abrasives. This brush is used to clean very dirty floors. We recommend using only the minimum necessary bare pressure to prevent damages to the floor.

### STEEL BRUSHES

Bristles are made of steel wire or flat blades, or are mixed steel and synthetic fibres. The steel brush is used to remove scale from badly uneven floors or floors with wide joints between tiles. Brushes with flat steel bristles (stiffer) are used to clean the toughest scale.

### BRISTLES THICKNESS

Thicker bristles are stiffer and should be used on smooth floors with narrow joints between tiles.

We recommend using softer bristles when floors are uneven or have deep joints or raised edges. Softer bristles penetrate easier into joints.

Remember that when brush bristles are worn and become too short they become stiffer and are no longer able to penetrate in depth. This is also because, as when using bristles that are too big, the brush tends to jump and skip.

### PAD HOLDER

Pad holder is recommended for cleaning polished surfaces.

There are two types of pad holders:

1. Traditional pad holders with set of anchor stubs that retain and drive the abrasive disk during operation.
2. CENTER LOCK pad holders which, in addition to anchor stubs, also have a plastic snap-in centre lock system. This permits perfect centring of the abrasive disk and ensures it is kept anchored without detaching. This type of pad holder is best for machines with several brushes, where it is difficult to centre the abrasive disks.

### LIST FOR THE CHOICE OF THE BRUSHES

Machine	Brushes N°	Code	Bristles type	Bristles Ø	Brush Ø	Remarks
ABILA 42	2	66805020	PPL	0.3	210	
		66805050	PPL	0.5	210	
		66805060	PPL	0.9	210	
		66805120	TYNEX	1	210	
		66705020	Pad holder		200	
ABILA 52	2	66808010	PPL	0.3	255	
		66808040	PPL	0.5	255	
		66808020	PPL	0.9	255	
		66808030	TYNEX	1	255	
		66708010	Pad holder		245	

REPLACE AND NULLIFY THE DOCUMENT RC2401 REV 01 ISSUED 10/2005-SS

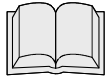

## READ THE USE AND MAINTENANCE HANDBOOK

### Inspection electric system

1. Check the functionality of the electric system:
  - brush motor (the motor ignition depends on the double consent of the **brush switch** and the **control levers**)
  - suction motor (ignite the motor through the **suction switch**).
2. Check the double function of the **display**, situated in the centre of the instrument board:
  - Under working conditions it is an indicator of the batteries charge level (4 full charge, 0= stop of the brush motor)
  - When no motor is activated the display indicates the open solution cock, when it remains lighted up.
3. Check the tightness of the **power contacts** of the electric system situated in the upper back part of the machine (behind the back panel).
4. Check the conditions and the correct assembly of the **fuses**.

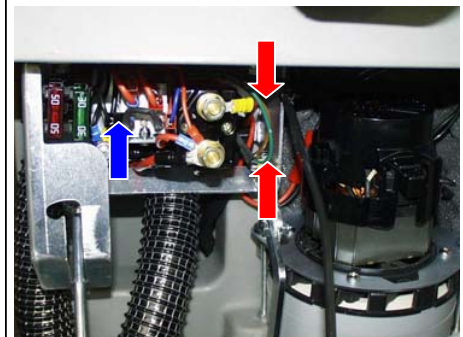
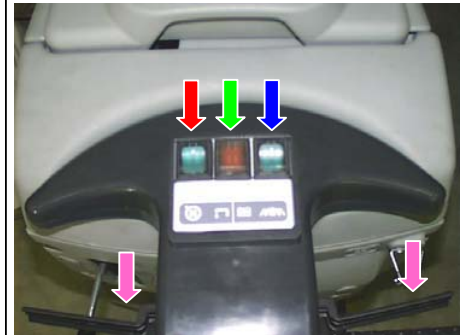

### Adjustment battery check card

1. Check-up the right set-up of the battery check card. The adjustment can be performed by **microswitches**.
2. The possibles configurations are the following:

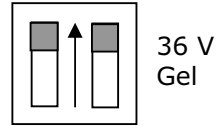
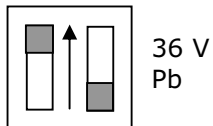
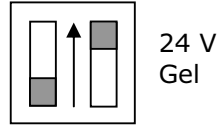
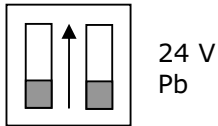

The right configuration is one of the two above depending on the battery type.

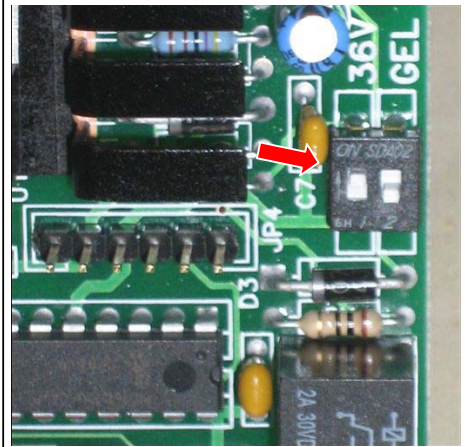
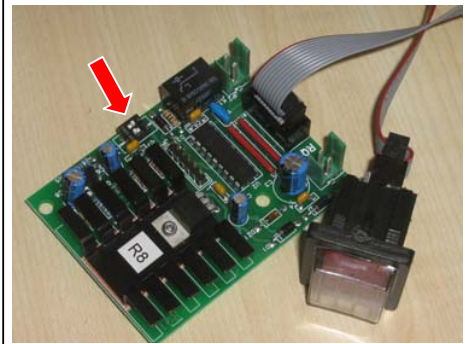

### Inspection of the water system

1. Fill up the solution tank and check the tightness of the fittings and in particular the gaskets of the **solution cock** and on the **solution filter**.
2. Check the distribution of water on the floor under the brush base is uniform and proportional to the opening of the solution cock. If necessary check the cleaning of the cock (see also next paragraph).
3. Check the internal cleaning of the filter and clean it if necessary and remove the obstructions
4. Clean the tank and let the water out of **opening**.

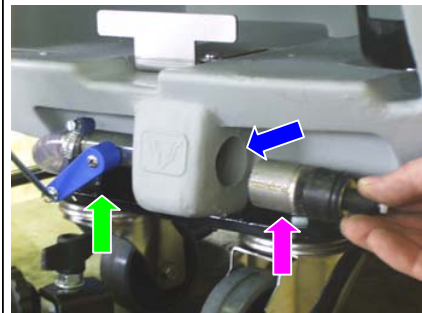

### Suction system test

1. To verify cleaning and functionality of the **filter - float**. The rod of the float has to move freely in the center of the filter.
2. Check, once closed, the tightness of the **cover** on the recovery tank verifying the complete tightness of the **gasket** on the flange filter.

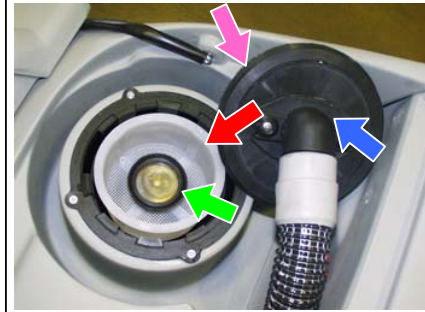

3. verify the correct insertion and the tightness of the **couplings** on the suction motor, on the squeegee and on the cover.
4. Check the tightness of the gaskets on the **squeegee mouthpiece**.

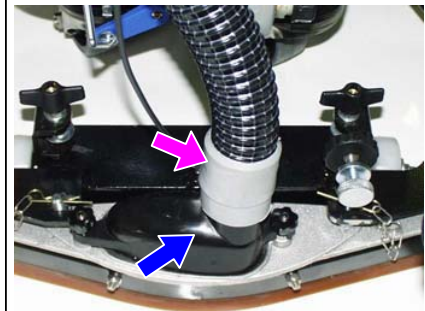

### Regulation brush base

#### 1. Regulation horizontal inclination brush base

- To position the machine on a plain and regular floor.
- Assembly the brushe and lower the brush base onto the floor.
- To loosen **nut** of the left lifting arm and adapt the brush base
- in the a right position to the floor.
- The slot rod of the brush base will be positioned automatically
- in the correct way.
- Screw nut and bolt.
- With this operation you set up a correct earth alignment of the brush base for a uniform floor cleaning.

**Attention** : by an incorrect adjustment the machine can go to the right or the backward direction.

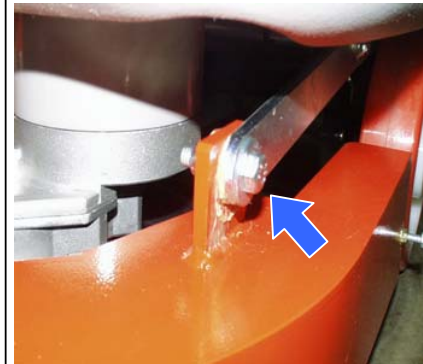
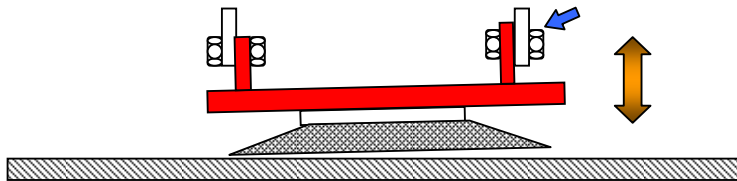

#### 2. Regulation vertical inclination brush base:

- To loosen **lock nut**.
- Adjust the brush base without brush so that it touches before on the back and it is higher 6-7 mm. on the front.
- Screw the block nut.
- The correct adjustment gives a correct inclination of the brush on the floor.

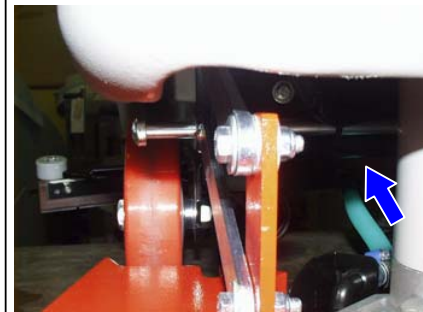
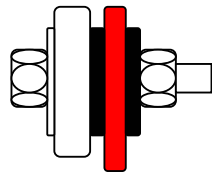

#### Traction adjustment

In order to adjust the traction operate upon the **screw** in the picture after having loosen the **knob**:

- Screw in order to increase the traction effect
- Unscrew in order to decrease the traction effect
- Fix the nut after the adjustment.

**Attention**: increasing the traction of the machine, the working capacity lower.

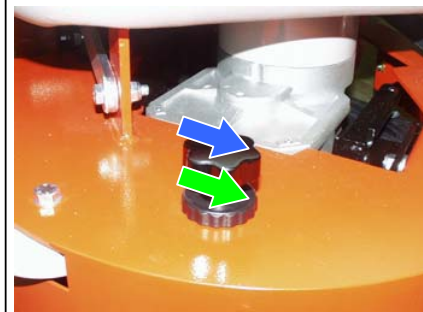

### Regulation touching of the brush

Check that the **round head screw** touch lightly the flat base of the brush. The space between the head and the brush have to be 1-2 mm. at the maximum when the brush is hooked and lowered.

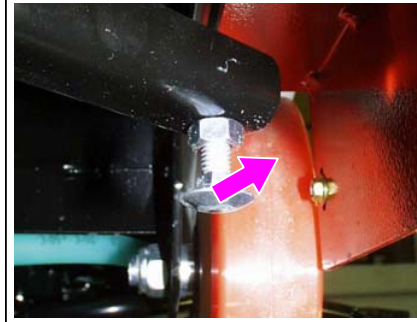

### Squeegee adjustment

#### 1. Adjustment squeegee lifting

- Loose the **nut**
- Screw the **threaded shaft** until the head of the shaft arrives
- to the fork base
- Fix the nut

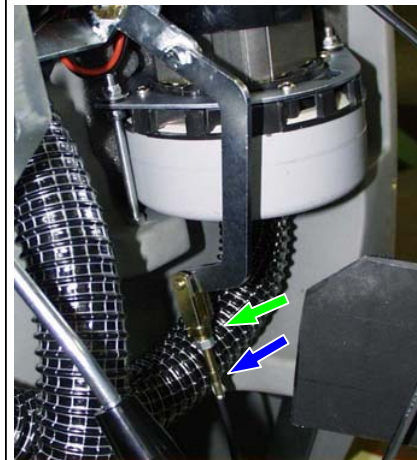
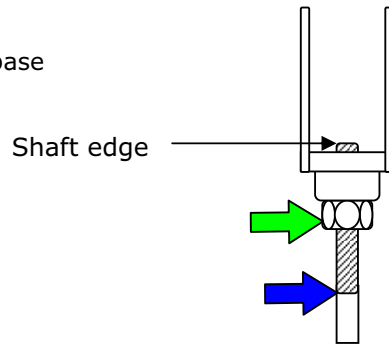

#### 2. Squeegee adjustment

The rubbers must have a inclination from 30° to 45° with respect to the floor and uniform over the complete squeegee length

For establishing this situation act upon the **knobs** for the regulation of the height and the balancing right/left of the squeegee on the floor.

For the rubber inclination act upon the **metal knob** and block the adjustment with the black plastic **hand wheel**.

Make sure that the adjustment is blocked.

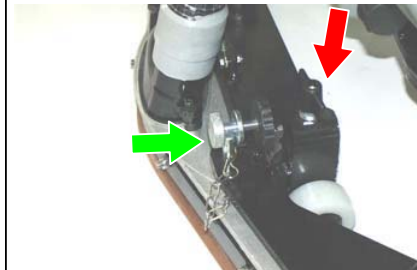
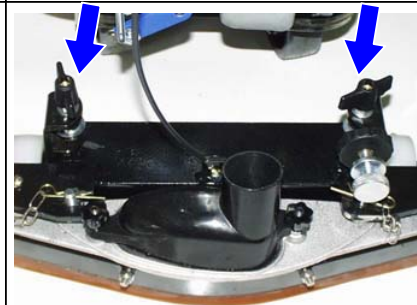
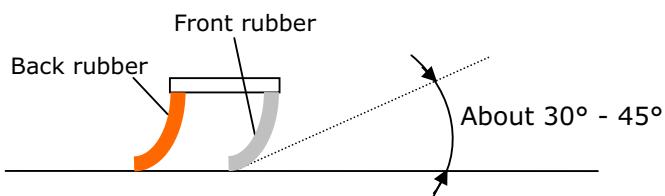



### Functional inspection of the machine

- Check the functionality of switches and lamps;
- Check the brush assembly functionality;
- Check the functionality of brush motor;
- Check the functionality of the squeegee;
- Check the functionality of suction motor;
- Check the functionality of handbrake;
- Check the conditions of battery connectors and cables;

### Functional test of the machine

- Fill the tanks with water and check their tightness;
- Check that solution fall on the brushes equally;
- Check the squeegee wheels with a functional test;
- Adjust the brush pressure and the brush assembly inclination doing a functional test;
- Check the functionality of the water cock;
- Check the braking efficiency;

### Final inspections

Control all functions: scrubbing, suction, traction.

**GRUPPO BASAMENTO ABILA 17B H2O CENTRALE**

BRUSH BASE ASSEMBLY

GROUPE PLATEAU DES BROSSES

GRUPPE BÜRSTENGESTELL

GRUPO BANCADA CEPILLO

01A

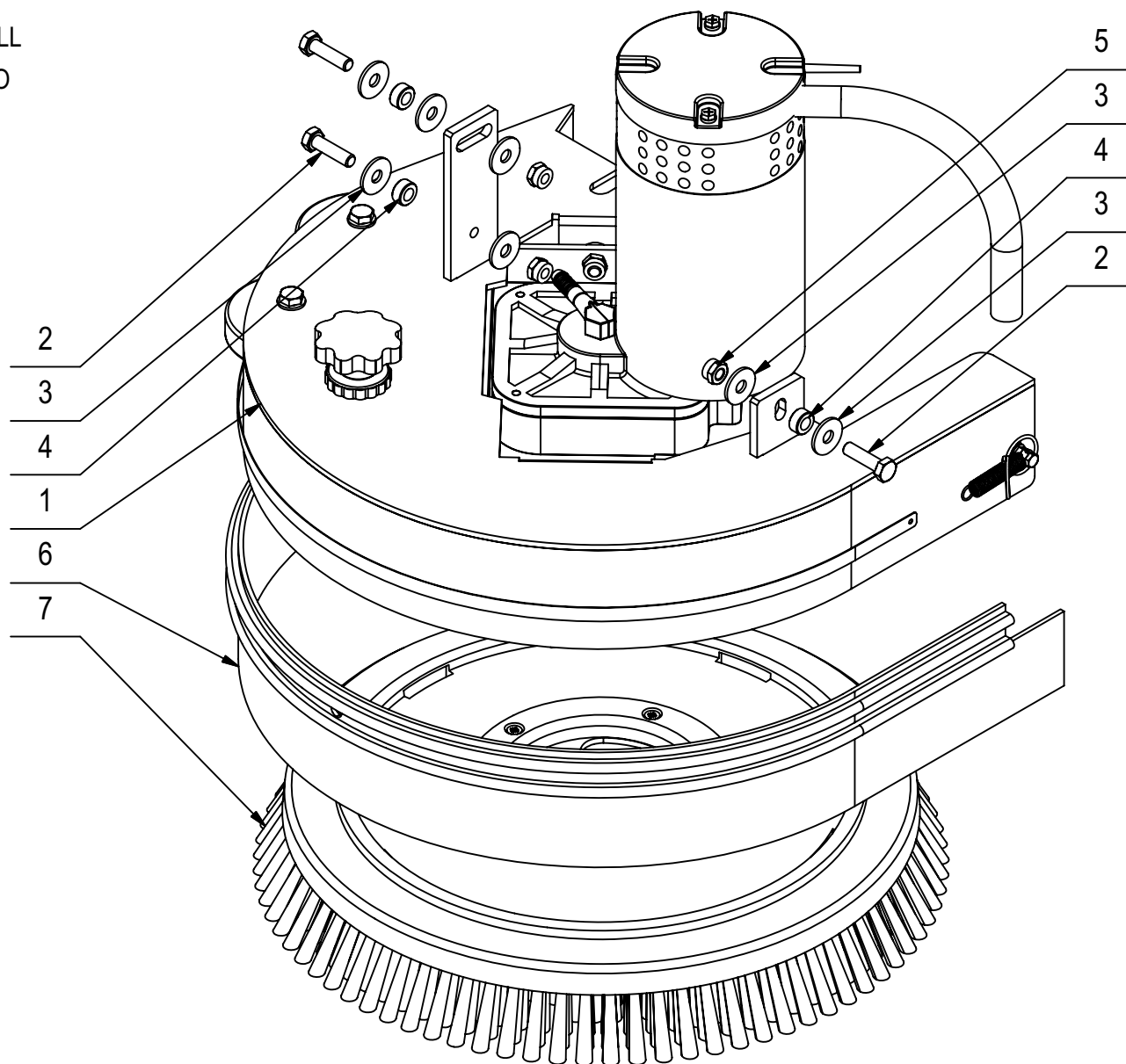

1.

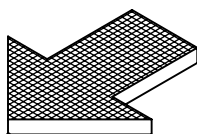

<b>ITEM</b>	<b>SKU</b>	<b>DESCRIPTION</b>	<b>QTY</b>
1	216740	BRUSH BASE ASSEMBLY	1
2	E83802	Hex Bolt M8x30 Zinc	3
3	E83404	Flat Washer M9x24x2.5 Zinc	7
4	E83970	Bushing	3
5	409085	LOCK NUT	3
6	E83295	splash guard WS17	1
7	405653	BRUSH	1

**PREM. BASAMENTO ABILA 17B H2O CENTRALE**

BRUSH BASE ASSEMBLY

GROUPE PLATEAU DES BROSSES

GRUPPE BÜRSTENGESTELL

GRUPO BANCADA CEPILLO

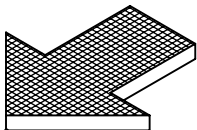
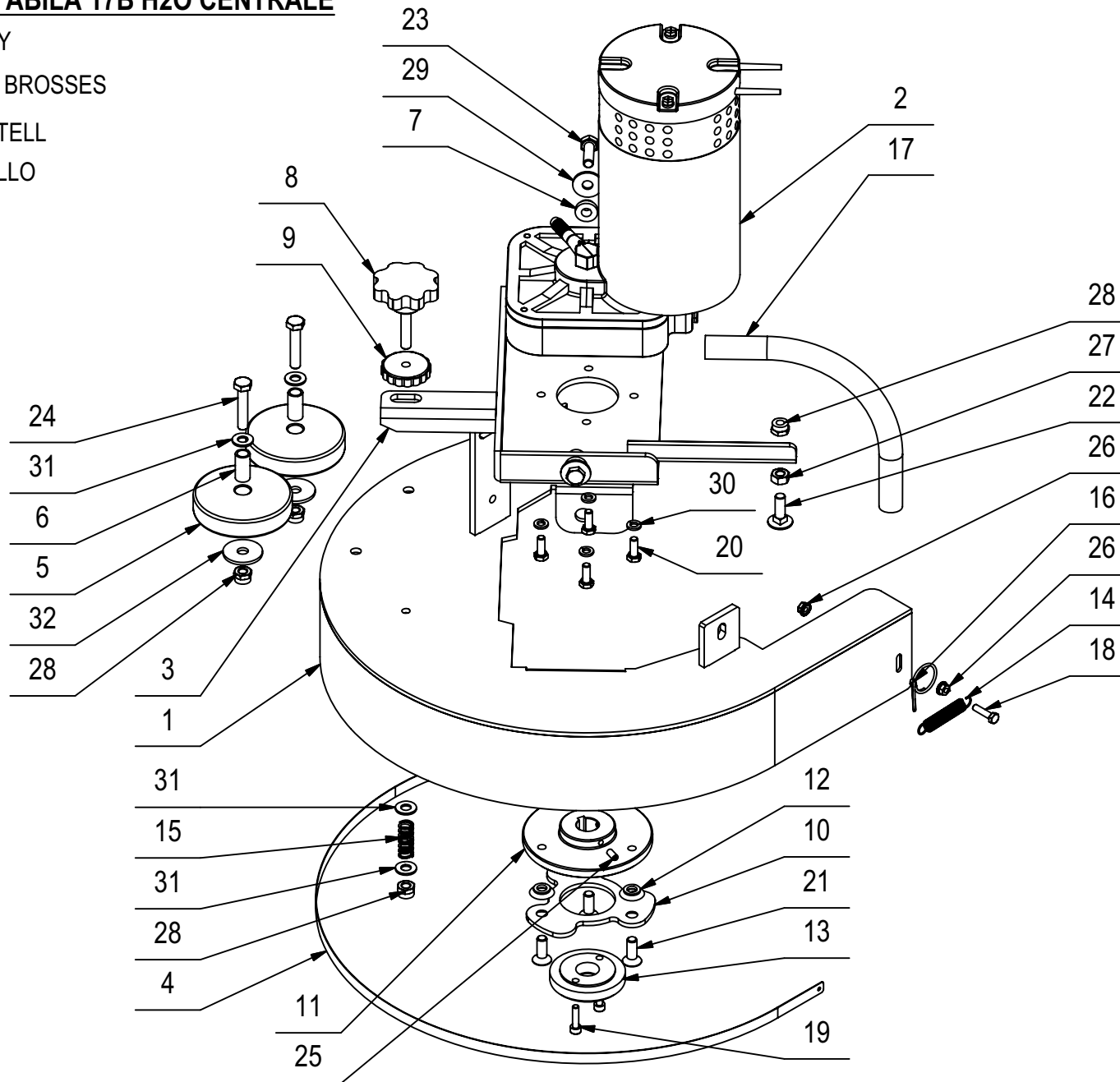
**02A**

ITEM	SKU	DESCRIPTION	QTY
1	E83645	Brush cover support	1
2	EP5009	Brush Gear Motor 24VDC 400W	1
3	206830	MOTOR SUPPORT	1
4	E83490	Splashguard band WS17	1
5	E83895	Wheel 80 OD x 23 W	2
6	E83524	Bushing	2
7	E82312	Bushing	2
8	410240	KNOB	1
9	E83331	Knob	1
10	E82844	Clutch Plate	1
11	E20418	Clutch Coupling, w/ Key Slot	1
12	E82845	Spacer	3
13	422582	FLANGE	1
14	E83491	Spring	2
15	E82309	Spring, Compression	2
16	E83489	Rings	2
17	209371	SHEATH	1
18	E83881	Hex Bolt M5x20 Zinc	2
19	415757	SCREW	2
20	E83547	M6x16 Bolt, Zinc Hex Head	4
21	E83826	Screw, M8x22	3
22	408623	SCREW	1
23	E83833	Hex Bolt M8x25 Zinc	2
24	E83830	Hex Bolt M8x40 Zinc	2
25	E20358	Set Screw Hex Soc Cone Point M5x1	2
26	E88010	Hex Nut, M5	4
27	E83656	Hex Nut, M8x6.5 Zinc	1
28	409085	LOCK NUT	6
29	E83404	Flat Washer M9x24x2.5 Zinc	2
30	E82774	Lock Washer, M6 Zinc	4
31	E81874	Flat Washer M8x17x1.6 Zinc	4
32	E81918	Flat Washer M9x32x2.5 Zinc	2

**GRUPPO TELAIO ABILA 17-20 B**

FRAME ASSY

GROUPE DE CHASSIS

RAHMEN GRUPPE

GRUPO BASTIDOR

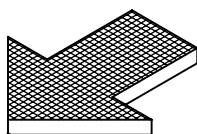
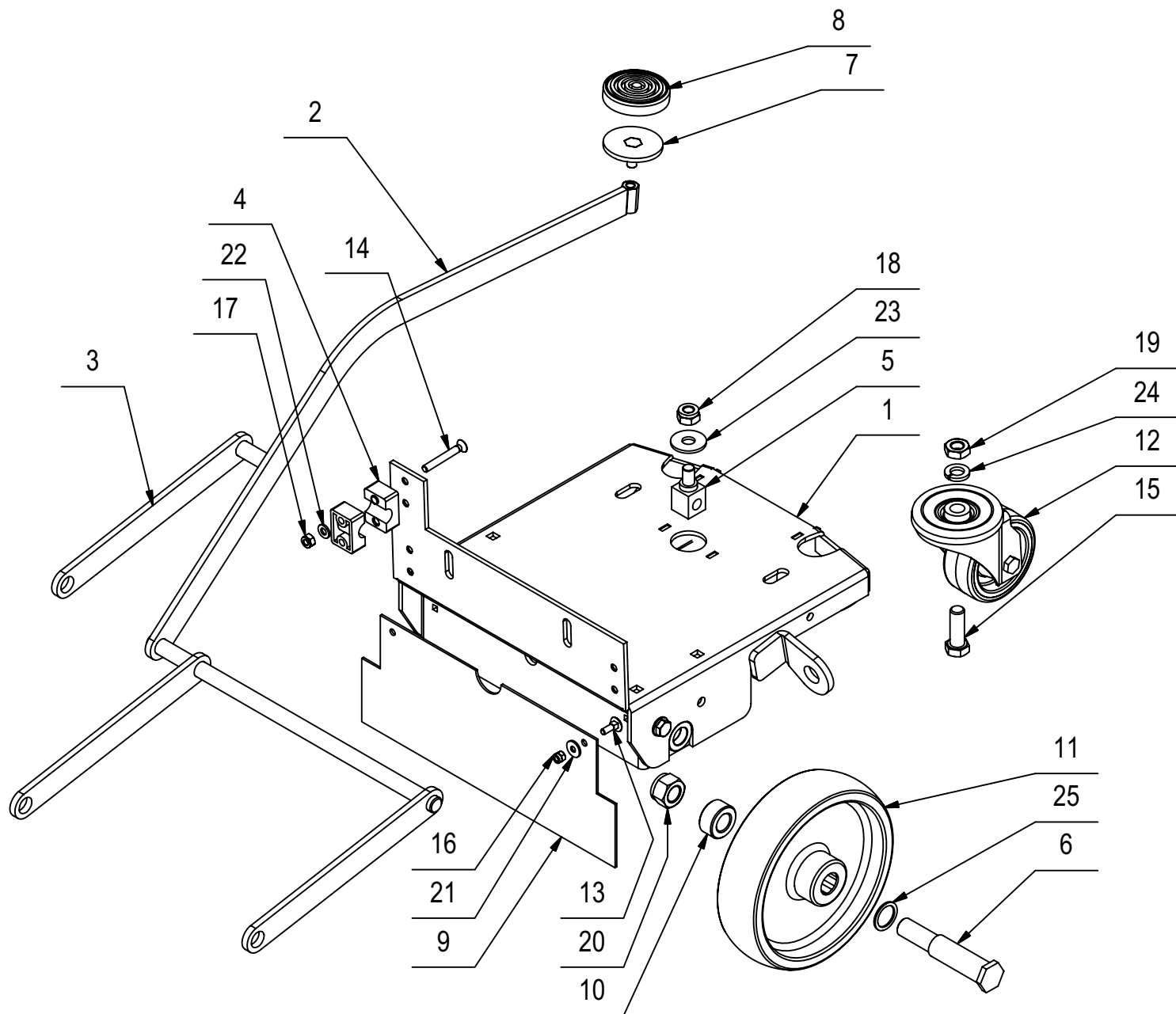
**03A**

ITEM	SKU	DESCRIPTION	QTY
1	407637	FRAME	1
2	E82525	Arm s42	1
3	E82833	Arm	1
4	E82834	Pivot Block	6
5	204226	COUPLING	1
6	215023	PIN	2
7	206838	PEDAL	1
8	E83669	Pedal cover	1
9	427244	SPLASH GUARD	1
10	E88103	Spacer	2
11	E82551	Transport Wheel 175 OD x 45 W	2
12	E82529	Caster, Rear Abila	2
13	408614	SCREW	2
14	E81635	Screw, M6X45	6
15	E81735	Hex Bolt M12x35 Zinc	2
16	409081	LOCK NUT	2
17	E83550	NyLoc Hex Nut, M6 Zinc	6
18	E83381	Nyloc Hex Nut, M10 Zinc	1
19	E83829	Hex Jam Nut, M12X7 Zinc	2
20	E81627	Nyloc Hex Nut, M16 Zinc	2
21	E20122	Flat Washer M5 x 15 x 1.5 SS	2
22	E82761	Washer 6x12x1.6	6
23	E81020	Washer, 11x30X2.5	1
24	E81738	Flat Washer M4x12x3 Zinc	2
25	E81948	Flat Washer M20x26x1.5 AL	2

**PREM. TERGIPAVIMENTO ABILA 17-42-52**

SQUEEGE ASSY

GROUPE DE SUCEUR

SAUGFUSS GRUPPE

GRUPO LIMPIAPAVIMENTOS

04A

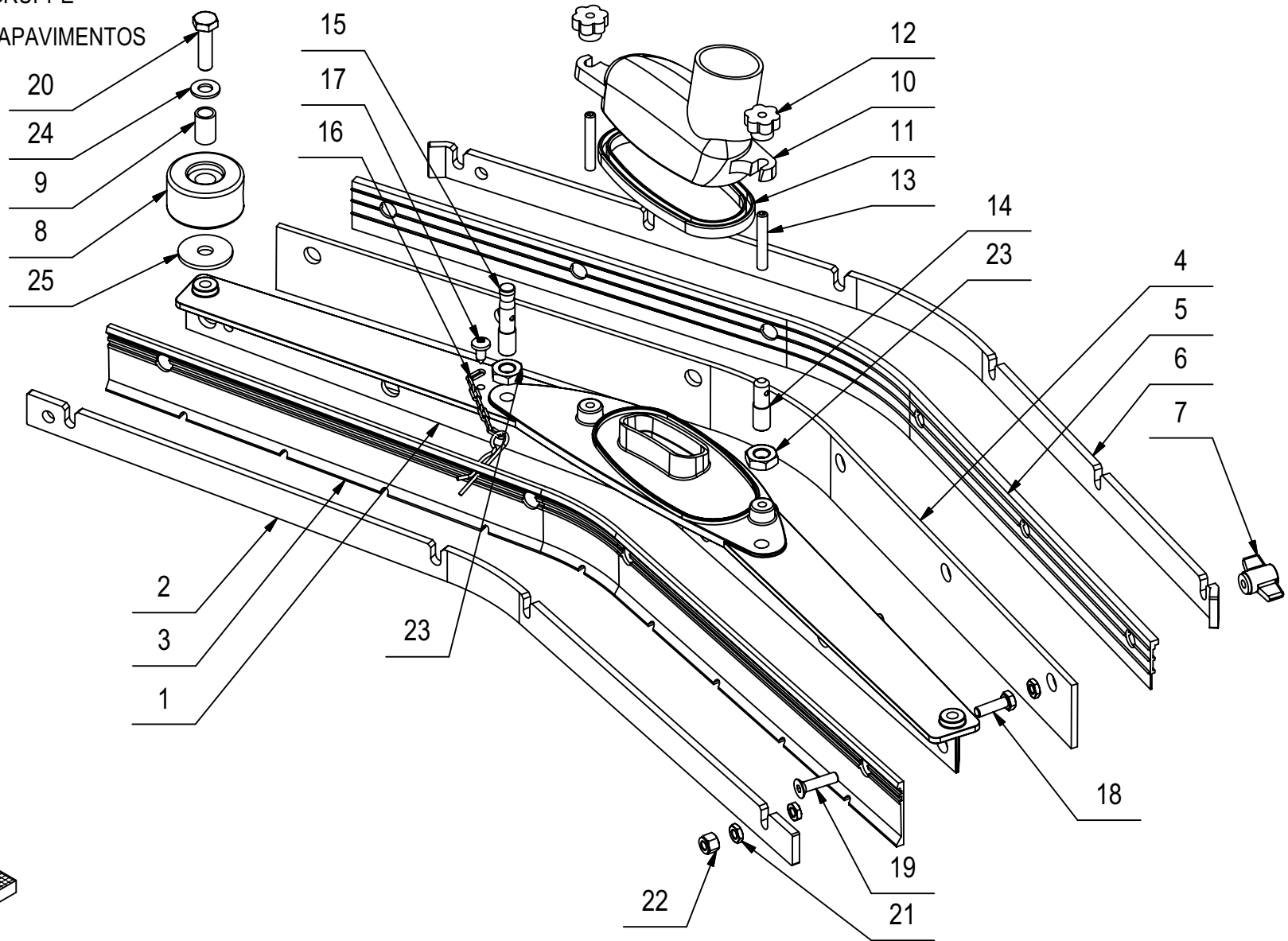

ITEM	SKU	DESCRIPTION	QTY
1	E82665	Squeegee Shoe	1
2	E81809	Band Clamp	1
3	E83327	Squeegee Blade, Front	1
4	E83417	Squeegee Blade, Gum Rubber 27" x 1 3/4" x 1/8"	1
5	E83326	Squeegee Blade, Polyurethane 27" x 1 7/16" x 1/8"	1
6	E81633	Band Clamp	1
7	E83591	Knob	6
8	E82451	Wheel 45 OD x 25 W	2
9	E82253	Bushing, Brass OD 11.95mm x ID 8.9mm x L 8.45mm	2
10	E82307	Squeegee Vacuum Adapter	1
11	E83971	Gasket	1
12	E83810	Knob	2
13	E82707	Set Screw Hex Soc Flat End M6x40 SS	2
14	E83945	Stud Bolt M10x33 Custom	1
15	E83911	Stud Bolt M10x46 Custom	1
16	E83590	Chain	1
17	E83851	Screw, Pan Hd Phil Self Tap M5.5x13 SS	1
18	E83914	Hex Bolt M6x20 SS	4
19	E81848	Flat Hd Soc Machine Screw M6x25 SS	6
20	E83802	Hex Bolt M8x30 Zinc	2
21	409045	NUT	14
22	E83550	NyLoc Hex Nut, M6 Zinc	4
23	E83875	Hex Jam Nut, M10X6 Zinc	2
24	E81874	Flat Washer M8x17x1.6 Zinc	2
25	E81918	Flat Washer M9x32x2.5 Zinc	2



ITEM	SKU	DESCRIPTION	QTY
1	213352	TANK ASM	1
1.1	217003	SOLUTION TANK ASM	1
1.1.1	E82319	Tank Abila Solution	1
1.1.2	E82332	Gasket	1
1.1.3	E83560	Filter Asm	1
1.1.4	E82612	Filter	1
1.1.5	E83561	Bracket WS17	1
1.1.6	E83533	Angle WS17	1
1.1.7	400893	SUPPORT	1
1.1.8	E82429	Cap	1
1.1.9	E83851	Screw, Pan Hd Phil Self Tap M5.5x13 SS	4
1.1.10	E83799	Flat Washer M6.6x18x2 SS	2
1.1.11	E81614	Stud bolt	2
1.1.12	E86701	Nut M6	2
1.1.13	E83550	NyLoc Hex Nut, M6 Zinc	2
1.1.14	E83547	M6x16 Bolt, Zinc Hex Head	2
1.1.15	E82774	Lock Washer, M6 Zinc	2
1.1.16	E83707	Deadening WS17	1
1.1.17	E82798	Washer, 6x18x1.5	2
1.2	217002	RECOVERY TANK ASM	1
1.2.1	E81470	Abila Recovery Tank	1
1.2.2	E83995	Ring	1
1.2.3	E83796	Screw, Pan Hd Phil Self Tap M4.2x16 Zinc	4
1.2.4	E82254	Chain Protector	2
1.2.5	E88430	Support Chain Tank Cover	2
1.2.6	E83881	Hex Bolt M5x20 Zinc	4
1.2.7	E82352	Cover, Abila	1
1.2.8	E83966	Hose Clamp	1
1.2.9	E88023	Hose, Drain Assembly Abila 42	1
1.2.10	E85764	Gasket	1
1.2.11	E85763	Connector	1
1.3	217007	PANEL ASSY	1
1.3.1	420031	PANEL	1
1.3.2	E83164	Micro Switch	1
1.3.3	408867	SCREW	2
1.3.4	E87296	Drain Hose Clip	1

**GRUPPO SERBATOI ABILA**

TANKS ASSY

GRUPE RESERVOIRS

TANK GRUPPE

GRUPO TANQUE

**06-07**

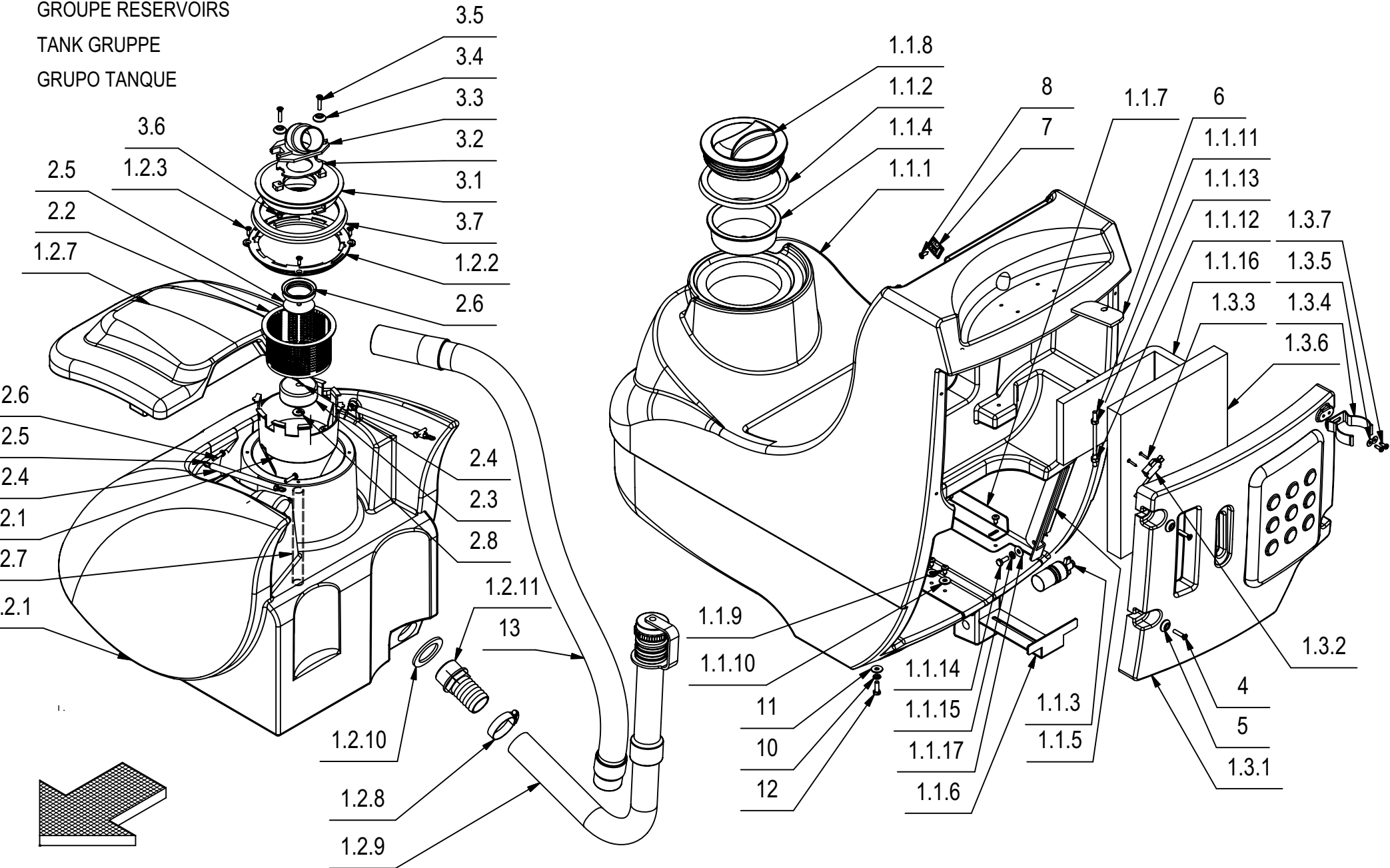

ITEM	SKU	DESCRIPTION	QTY
1.3.5	E83037	Flat Washer M4x12x1.6 Zinc	2
1.3.6	E85784	Vac Motor Deadening	1
1.3.7	408879	SCREW	2
2	200823	FLOAT PROTECTION ASSY	1
2.1	E81006	Vacuum Splash Guard	1
2.2	E81615	Filter	1
2.3	E83338	Float WS17	1
2.4	E83605	Split pin	2
2.5	E82611	Rod	1
2.6	E82313	Grommet	1
2.7	E82490	Hose, Abila	1
2.8	E83799	Flat Washer M6.6x18x2 SS	1
3	200691	PLUG ASSY	1
3.1	E82450	Cover	1
3.2	E83994	Gasket	1
3.3	E82267	Coupling	1
3.4	E83850	Flat Washer M5x20 SS	2
3.5	E83934	Screw m5x25	2
3.6	409081	LOCK NUT	2
3.7	E82381	Gasket Ring	1
4	E83934	Screw m5x25	4
5	E83850	Flat Washer M5x20 SS	4
6	405966	GASKET	2
7	E81619	Cable Tie Holder	4
8	E83796	Screw, Pan Hd Phil Self Tap M4.2x16	4
9	407668	SCREW	2
10	E82774	Lock Washer, M6 Zinc	4
11	E82798	Washer, 6x18x1.5	4
12	407665	SCREW	2
13	E83536	Squeegee hose	1

**GRUPPO COMANDO TERGI ABILA B**

SQUEEGE CONTROL ASSY

COMMANDE DE SUCEUR

SAUGFUSS KONTROLL GRUPPE

GRUPO COMANDO LIMPIAPAVIMENTOS

**05A**

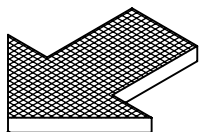
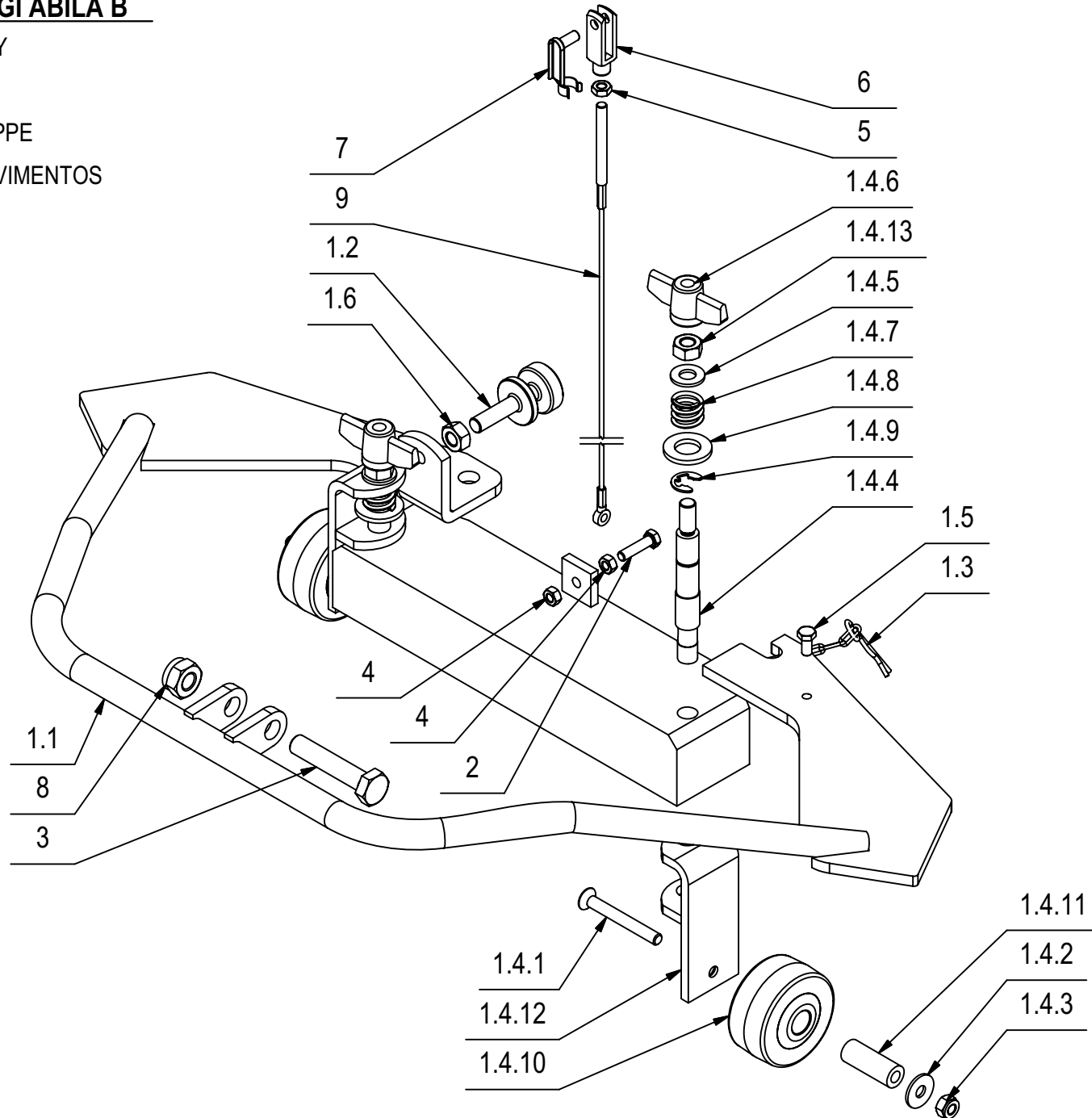

ITEM	SKU	DESCRIPTION	QTY
1	200821	SQUEEGEE CONTROL ASM	1
1.1	E86246	Coupling, Squeegee	1
1.2	E83655	Adjuster Knob	1
1.3	E83590	Chain	1
1.4	203067	SUPPORT WHEEL ASSY	2
1.4.1	408974	SCREW	1
1.4.2	E82798	Washer, 6x18x1.5	1
1.4.3	E83550	NyLoc Hex Nut, M6 Zinc	1
1.4.4	E82329	Threaded Pin	1
1.4.5	E81874	Flat Washer M8x17x1.6 Zinc	1
1.4.6	E83531	Knob	1
1.4.7	E81634	Spring Compression	1
1.4.8	E85722	Flat Washer M13x24x2.5 Zinc	1
1.4.9	E85498	E Style Circlip	1
1.4.10	E82428	Wheel 52 OD x 28 W	1
1.4.11	E82273	Bushing	1
1.4.12	E85497	Weldment, Squeegee Wheel Support	1
1.4.13	E83656	Hex Nut, M8x6.5 Zinc	1
1.5	418312	SCREW	1
1.6	E83656	Hex Nut, M8x6.5 Zinc	1
2	E83881	Hex Bolt M5x20 Zinc	1
3	408724	SCREW	1
4	E82317	Hex Jam Nut, M5X3.5 Zinc	2
5	415887	NUT	1
6	E86154	Fork	1
7	E81907	Pin	1
8	E83381	Nyloc Hex Nut, M10 Zinc	1
9	E85768	Squeegee Cable	1

**GRUPPO ASPIRAZIONE ABILA**

SUCTION MOTOR ASSEMBLY

GROUPE MOTEUR D'ASPIRATION

SAUGMOTORGRUPE

GRUPO MOTOR SUCCION

07

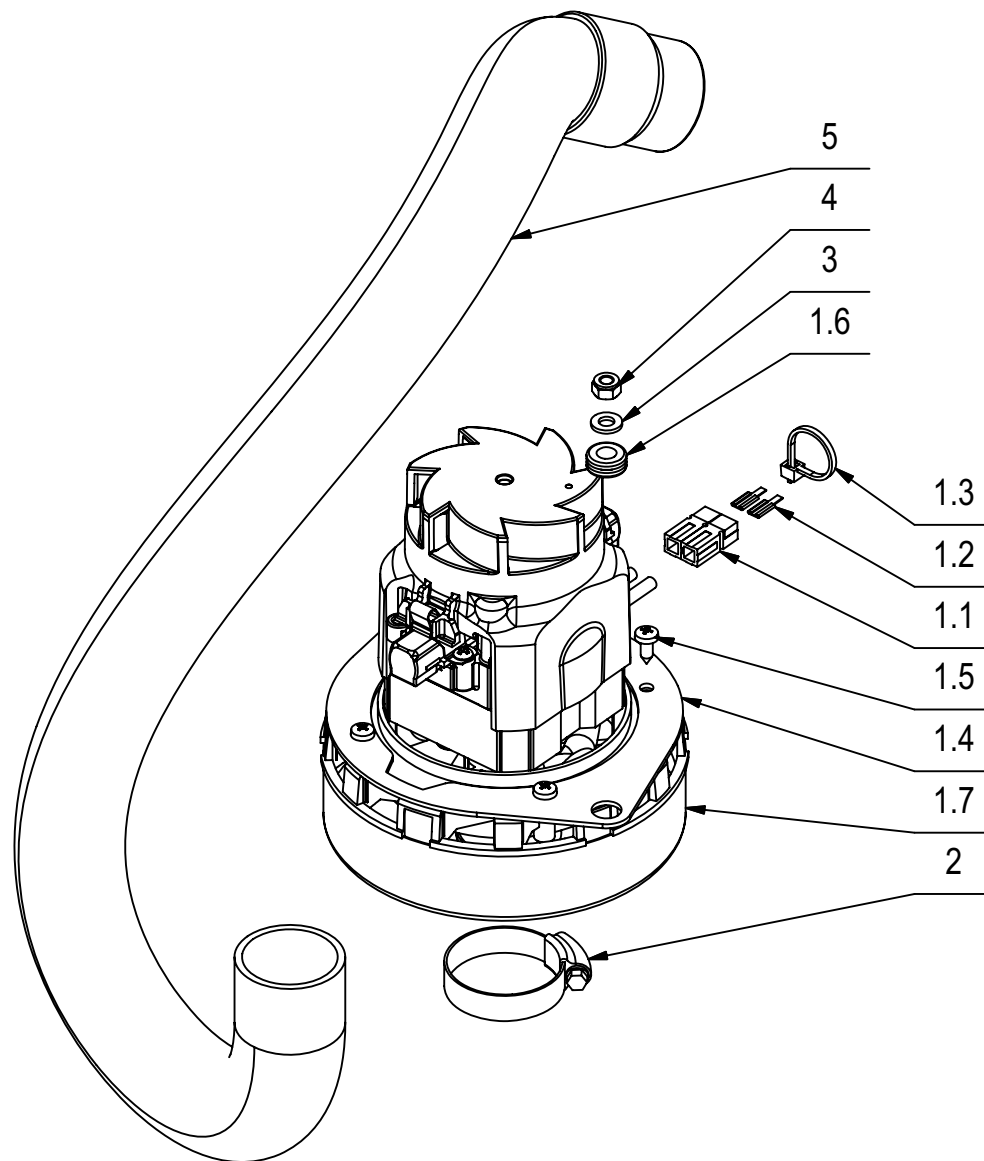

1.

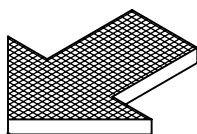

<b>ITEM</b>	<b>SKU</b>	<b>DESCRIPTION</b>	<b>QTY</b>
1	E83454	Motor asp 24 volt	1
1.1	E83897	Connector, Electrical Housing 30A	2
1.2	E83883	Lug, Electrical 30A	2
1.3	E83935	Wire Tie	1
1.4	E82838	Motor Plaque	1
1.5	E88017	Screw, Pan Hd Phil Self Tap M4.8x13 SS	4
1.6	E87975	Stud Bolt Tripla	2
1.7	407504	SUCTION MOTOR	1
2	E83966	Hose Clamp	1
3	E82761	Washer 6x12x1.6	2
4	E83550	NyLoc Hex Nut, M6 Zinc	2
5	E82371	Vac exhaust hose	1

**GRUPPO IMP. IDRICO ABILA 17-20-42-52**

WATER UNIT

GROUPE HIDRIQUE

WASSERGRUPPE

GRUPO AGUA

08

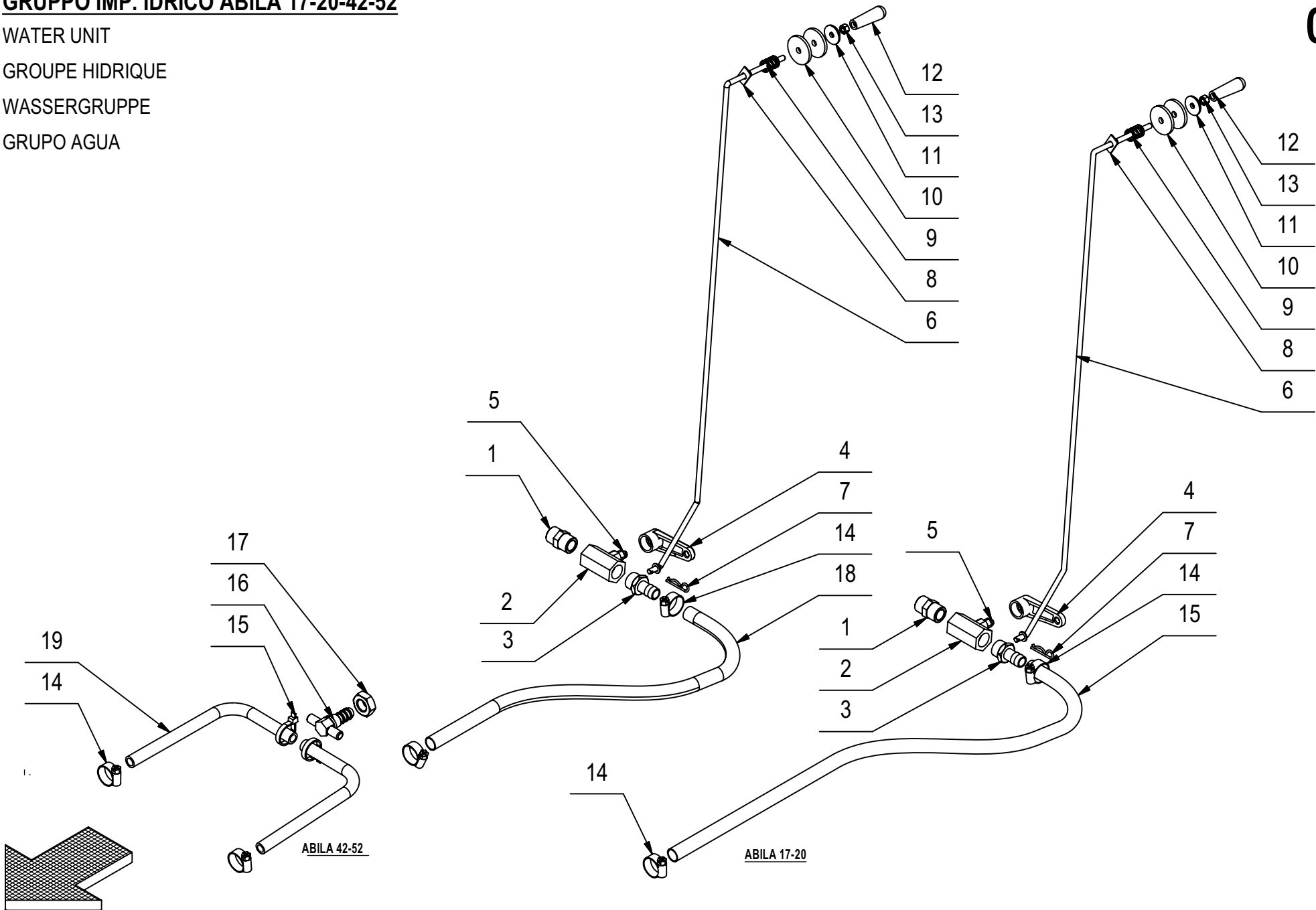

**ABILA 42-52**

ITEM	SKU	DESCRIPTION	QTY
1	E83943	Nipple, Double Male 3/8"	1
2	E83361	Ball Valve, 5/8 Double Female	1
3	E82269	Barbed Fitting, 3/8 in.	1
4	E83534	Solution valve lever	1
5	E83816	Screw	1
6	E83532	Solution rod	1
7	E83537	Clip	1
8	E83845	Nut, M5	1
9	E82309	Spring, Compression	1
10	E83798	Flat Washer M6x30x3 PVC Black	2
11	E83850	Flat Washer M5x20 SS	1
12	E83639	Solution control knob	1
13	E83535	Hex Nut, M5x5 Zinc	1
14	E83499	Clamp DRS/CRS	4
15	E81565	Clamp, 4.8x200 Black	2
16	400884	DISTRIBUTORE SENZA LAMELLA	1
17	E88198	Nut	1
18	E82693	Hose, 17 OD x 12 ID x L 420	1
19	E82494	Tube, Solution Abila	2

**ABILA 17-20**

ITEM	SKU	DESCRIPTION	QTY
1	E83943	Nipple, Double Male 3/8"	1
2	E83361	Ball Valve, 5/8 Double Female	1
3	E82269	Barbed Fitting, 3/8 in.	1
4	E83534	Solution valve lever	1
5	E83816	Screw	1
6	E83532	Solution rod	1
7	E83537	Clip	1
8	E83845	Nut, M5	1
9	E82309	Spring, Compression	1
10	E83798	Flat Washer M6x30x3 PVC Black	2
11	E83850	Flat Washer M5x20 SS	1
12	E83639	Solution control knob	1
13	E83535	Hex Nut, M5x5 Zinc	1
14	E83499	Clamp DRS/CRS	2
15	E82306	Hose	1

**GRUPPO IMP. ELETTRICO ABILA B**

ELECTRIC COMPONENTS

COMPOSANTS ELECTRIQUES

ELEKTROTEILE

COMPONENTES ELÉCTRICOS

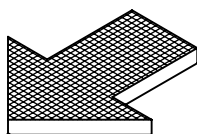
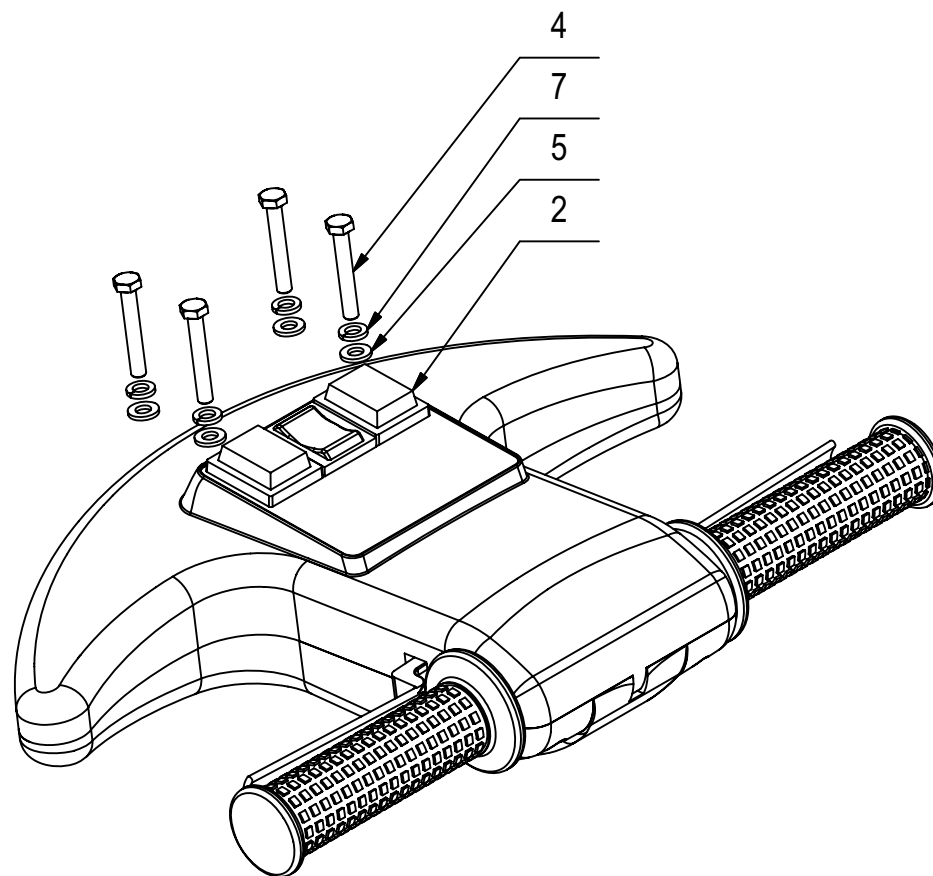
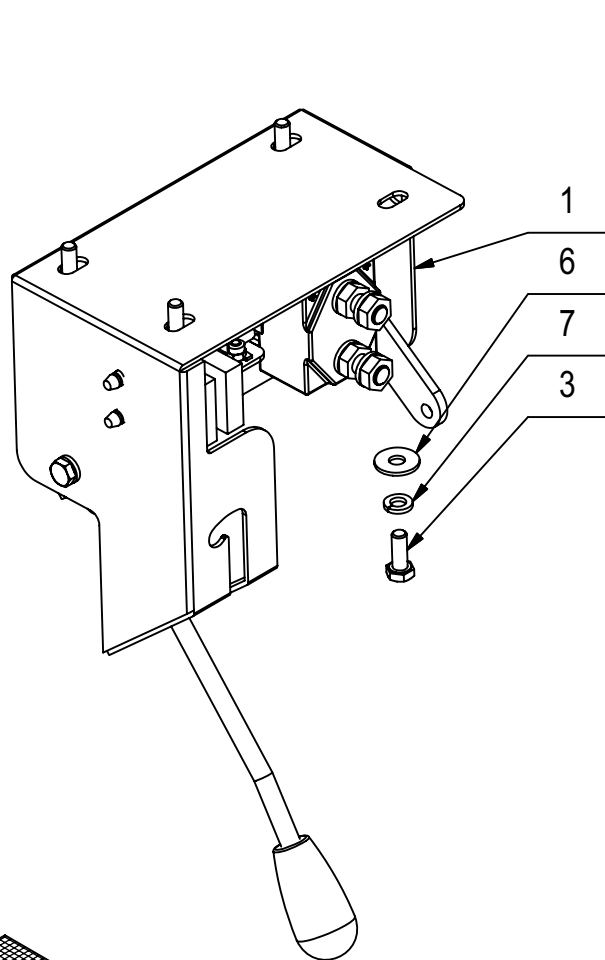
**09A**

<b>ITEM</b>	<b>SKU</b>	<b>DESCRIPTION</b>	<b>QTY</b>
1	202966	ELECTRIC SYSTEM	1
2	200822	HANDLE BAR	1
3	E83547	M6x16 Bolt, Zinc Hex Head	4
4	E81983	Hex Bolt M6x40 Zinc	4
5	E82761	Washer 6x12x1.6	4
6	E82798	Washer, 6x18x1.5	4
7	E82774	Lock Washer, M6 Zinc	8

**PREM. MANUBRIO ABILA B**

HANDLE BAR

TIMON

LENKSTANGE

MANILLAR

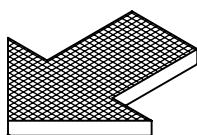
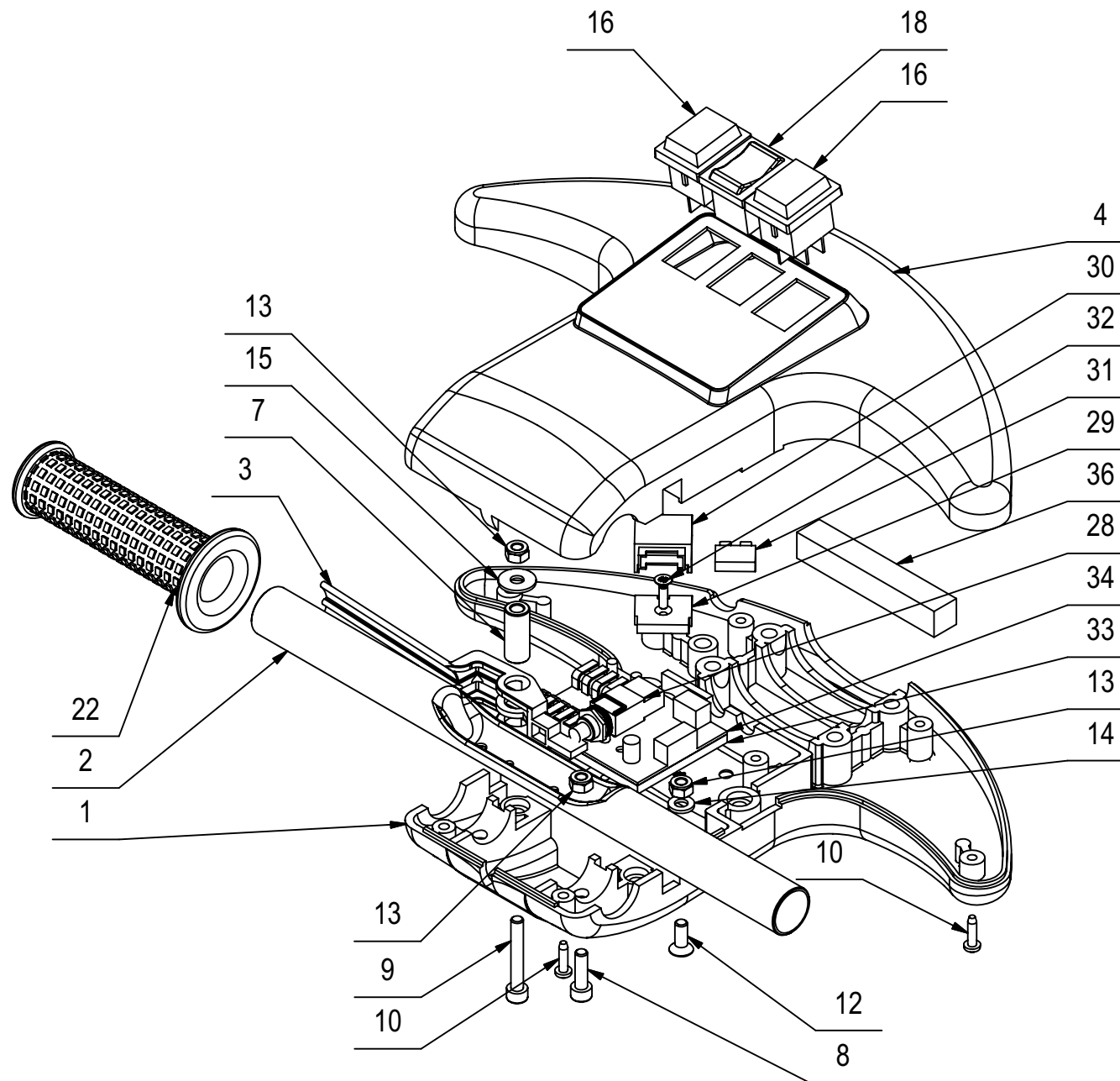
**10A**

ITEM	SKU	DESCRIPTION	QTY
1	E83407	Handle bar body WS17	1
2	E83408	Handle bar (pipe) WS17	1
3	E83465	WS17 lever	2
4	E83405	Handle bar cover WS17	1
7	E82308	Pin	2
8	408796	VITE M6x20 TCEI UNI 5931 ZINC	2
9	E20342	Soc Hd Cap Screw M6x40 Zinc	2
10	408881	VITE D.4,2x16 AUTOF. UNI 6954	4
12	E88042	Flat Hd Soc Machine Screw M6x16 Zinc	1
13	E83550	NyLoc Hex Nut, M6 Zinc	5
14	E82761	Washer 6x12x1.6	1
15	E82798	Washer, 6x18x1.5	2
16	E83328	Vacuum switch	2
18	E83175	battery level display	1
22	E83615	Handle grip WS17	2
28	E82796	Switch, Momentary	1
29	409869	PIASTRINA ATTACCO	1
30	E88244	Fuse Holder for Crewman AS20B	1
31	E83168	Fuse, 3 amp	1
32	E86144	Screw, Battery Cover	1
33	E82704	Gasket	1
34	E83157	battery indicator card	1
36	209359	PROFILO MOUSSE 15x15x92	1

**PREM. IMPIANTO ELETTRICO ABILA B-BT**

ELECTRIC COMPONENTS

COMPOSANTS ELECTRIQUES

ELEKTROTEILE

COMPONENTES ELÉCTRICOS

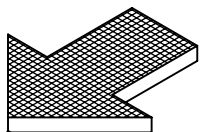
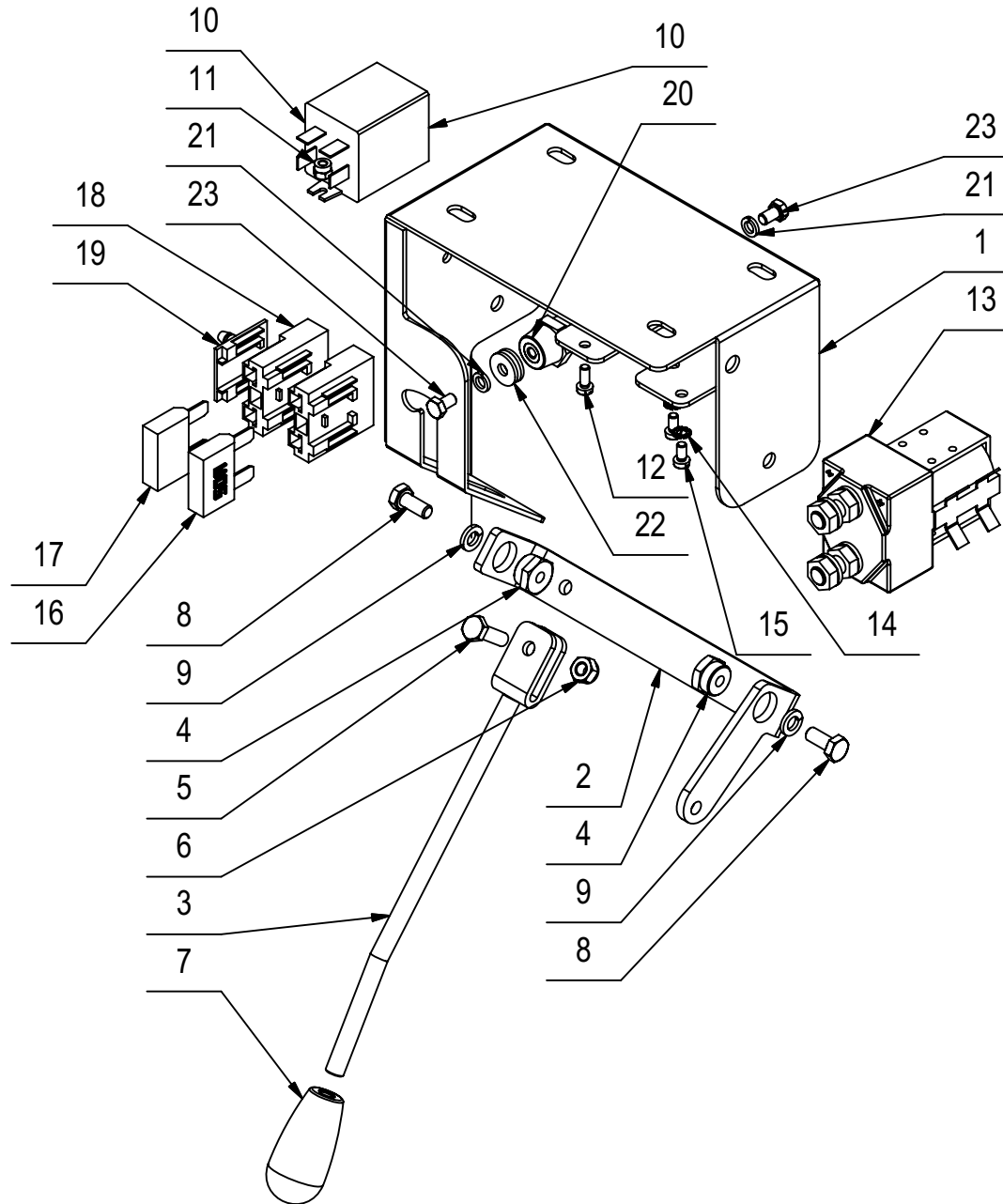

ITEM	SKU	DESCRIPTION	QTY
1	204228	COUPLING	1
2	E83540	Lever WS17	1
3	E82550	Handle - Lever S42	1
4	E82698	bushing	2
5	E82772	Hex Bolt M6x20 Zinc	1
6	E83550	NyLoc Hex Nut, M6 Zinc	1
7	E81477	Knob 25X50 M8	1
8	E82456	Hex Bolt M6x14 Zinc	2
9	E82774	Lock Washer, M6 Zinc	2
10	E83160	Relay 24VDC 30A	1
11	E83867	Nyloc Hex Nut, M4x6 Zinc	1
12	E83887	Screw M4X10	1
13	E83628	Contactora 24VDC	1
14	E81954	Washer, Lock	2
15	E83816	Screw	2
16	E82305	Fuse 50A faston brushes motor	1
17	E83972	Fuse 30A fasten	1
18	E81642	Fuseholder	2
19	E88497	Fuse Block End Cap	1
20	E83664	Insulator WS17	1
21	E20123	Lock Washer M5x1.6 Zinc	2
22	E20122	Flat Washer M5 x 15 x 1.5 SS	2
23	E81437	Screw	2
24	427722	CABLES	1

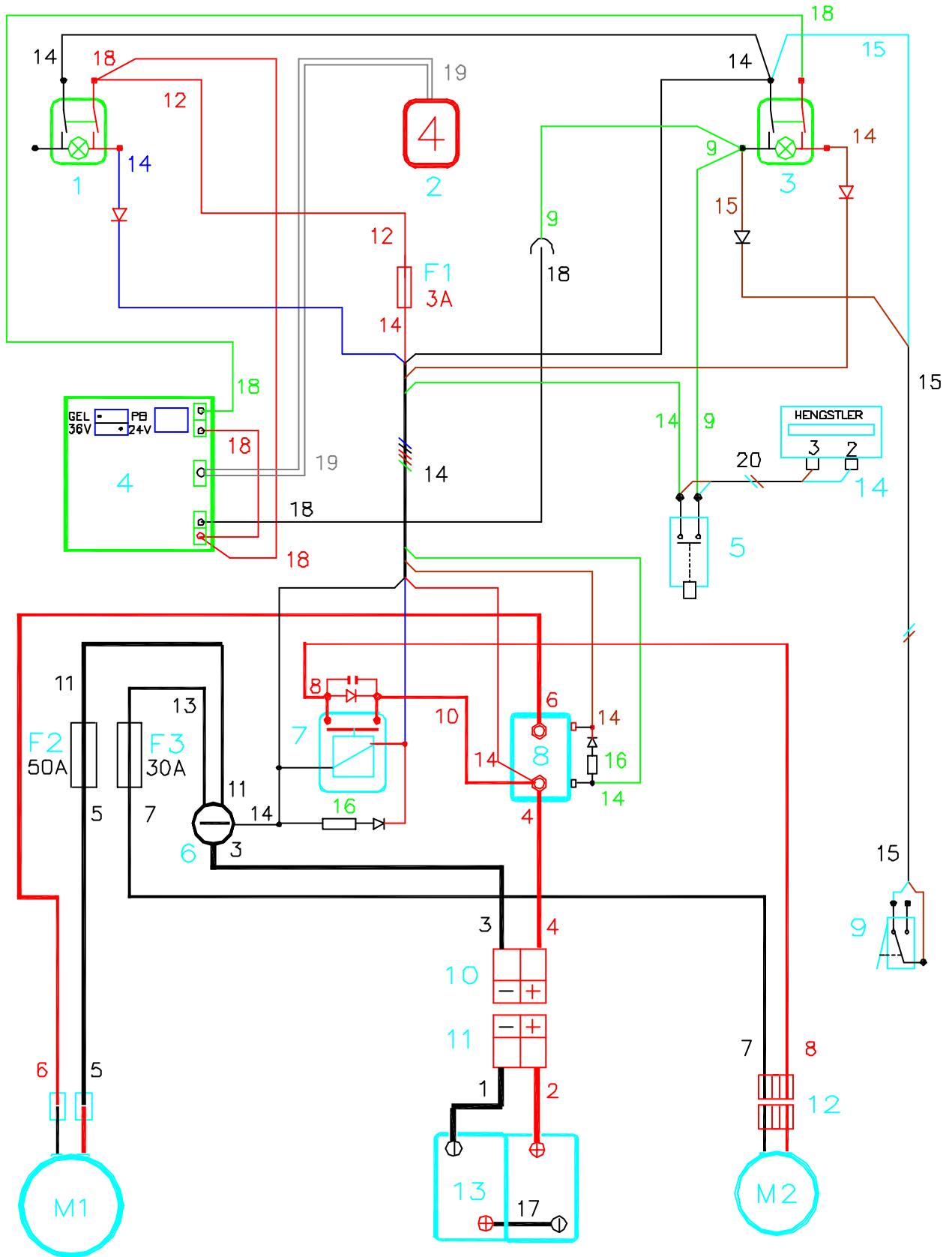

Dalla Matricola 03004404

03	13/01/04	Diventa Abila 17-42-52	Olivo	Zanardi	Guerra
02	16/12/02	Eliminato diodo su cavo 9	Olivo	Dalla Verde	Guerra
01	12/02/2002	Introduz. scheda contr. batt.+cambio numeraz.fusibili+Abila	Olivo	Dalla Verde	Guerra
REV.	DATA	MOTIVO	DISEGNATO	CONTROLLATO	APPROVATO

COMMA S.p.A.

S. Giovanni Lupatoto VERONA

DISEGNATO	Olivo	CONTROLLATO	Dalla Verde	APPROVATO	Guerra	DATA REVISIONE 0	04/10/2001
MACCHINA	Abila 17-42-52			CODICE		75124005	
GRUPPO	Impianto Elettrico			N° DISEGNO		24.51.02	
OGGETTO	Schema Impianto Elettrico e componenti						

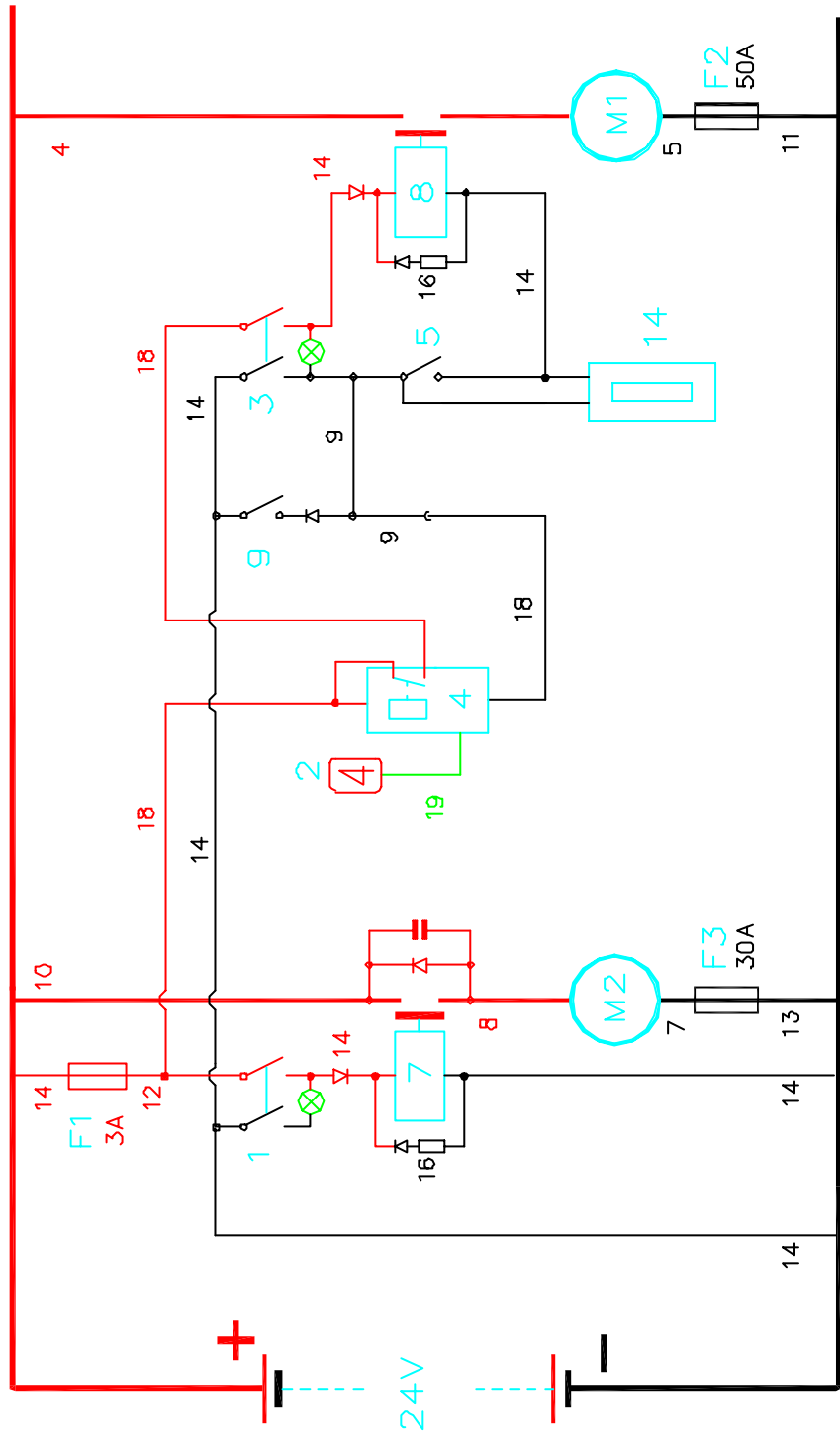

Dalla Matricola 03004404

03	13.01.04	Diventa Abila 17-42-52	Olivo	Zanardi	Guerra
02	16.12.02	Eliminato diodo su cavo 9	Olivo	Dalla Verde	Guerra
01	12/02/02	Introduz. scheda contr.bat.+ cambio numeraz. fusibili+Abila	Olivo	Dalla Verde	Guerra
REV.	DATA	MOTIVO	DISEGNATO	CONTROLLATO	APPROVATO

			S. Giovanni Lupatoto VERONA		
DISEGNATO	Olivo	CONTROLLATO	Dalla Verde	APPROVATO	Guerra
MACCHINA	Abila 17-42-52			DATA REVISIONE o	04/10/2001
GRUPPO	Impianto Elettrico			CODICE	75124005
OGGETTO	Schema Funzionale			N° DISEGNO	24.51.01

ITEM	SKU	DESCRIPTION	ITEM	SKU	DESCRIPTION CABLES
1	E83328	Vacuum switch	1-2	68024001	Cables black-red+battery terminals +
2	E83175	battery level display	3-4	68024002	Cables black-red + conn. 50A -3/4-
3	E83328	Vacuum switch	5-6	68024003	Cables black-red with couplings -5/6-
4	E83157	battery indicator card	7-8	68024004	Cables black-red + conn. 30A -7/8-
5	E82796	Switch, Momentary	9	E83844	Cable
6	E83664	Insulator WS17	10	E86168	Cable, Red/Diode/Condenser
7	E83160	Relay 24VDC 30A	11	68024007	Cable black -11-
8	E83628	Contactora 24VDC	12	68024018	Cable red -12-
9	E83164	Micro Switch	13	68024009	1 Cable black -13-
10	E83253	Male connector lug (Fr.)	14	68024010	Cable 5x1 + black bridges -14-
11	72700012	Connector female 50A	15	68024011	2 Cables blue-brown -15-
12	72700007	Connect. double 30A suction motor	16	E82372	Diode and Resistance w/ Terminal
13	E11767	Batteries	17	68024013	Cable black battery bridge -17-
14	72904005	Hourmeter self-fed (optional)	18	68024017	3 Cables black-red-green+conn.+brid.
M1	E82576	Brush Motor 24VDC 400W	19	68000892	Cable display battery signal -19-
M1	68200550	Brushes motor 24V (Abila 17)	20	68024016	2 Cables blue-brown -20- (opt.hourm.)
M2	E83454	Motor asp 24 volt			
F1	E83168	Fuse, 3 amp			
F2	E82305	Fuse 50A faston brushes motor			
F3	E83926	Fuse 301 faston suction motor			

CODICE	Q.	NR.	P.	
68024001	1	1	-	MORS. ⊕ + COPRI MORSETTO BATTERIA NERO 10 X 750
	2	+		MORS. ⊕ + COPRI MORSETTO BATTERIA ROSSO 10 X 750
				STAGNATI 72700029 STAGNATI 72700012 CONN. 50A
68024002	1	3	-	5  NERO 10 X 300
	4	+		8  ROSSO 10 X 350
				STAGNATI CONN. 50A 72700011
68024003	1	5	-	MAXI  NERO 6 X 1300
	6	+		8  ROSSO 6 X 1200
				GUAINA 1000 NL2-M NL2-M
68024004	1	7	-	MAXI  ROSSO 2,5 X 300
	8	+		6  ROSSO 2,5 X 300
				CONN. 30A
68024005	1	9		6  VERDE 1 X 300
				6  VERDE 1 X 100
68024006	1	10	+	8  ROSSO 2,5 X 170
				0.47MF 1N4007
68024007	1	11	-	MAXI  NERO 4 X 150
68024018	1	12	+	6  ROSSO 1 X 250
68024009	1	13	-	MAXI  NERO 2,5 X 150
68024010	1	14		6  GUAINA 150
				6  GUAINA 150
				8  5 X 1 X 600
				6  NERO 1 X 150
				6  NERO 1 X 100
				1N4007 1N4007
68024011	1	15		6  50
				6  2 X 0,5 X 600
				80 1N4007

CODICE	Q.	NR.	P.	
72500011	2	16		6  RESIST. 270 Ω
				TERMORETRAIBILE 1N4007
68024013	1	17	-	MORS. ⊕ + COPRI MORSETTO BATTERIA NERO 10 X 450
				STAGNATO + COPRI MORSETTO BATTERIA
68024017	1	18		6  VERDE 0.5 X 220
				AMP AMP
				ROSSO 0,5 X 100
				AMP AMP
				6  NERO 0,5 X 170
				6  ROSSO 0.5 X 340
68000892	1	19		CAVO FLAT 10 X 500 DISPLAY BATTERIE
68024016	1	20		OPTIONAL CONTAORE
				PKE PKE
				2 X 0,5 X 500
				AMP AMP

04	16/12/2002	Eliminato diodo su cavo 9	Olivo	Dalla Verde	Guerra
03	05/11/2002	Correzione su capicorda cavo 20; annulla dis.24.51.04	Olivo	Dalla Verde	Guerra
02	20/03/2002	Allung.10mm+manetta con. cavo 1-2 occhiello d.5 cavo14	Olivo	Dalla Verde	Guerra
1	15/02/2002	Rev.cavo12+agg.cavi18-19 (scheda contr.batt.)+nome Abila	Olivo	Dalla Verde	Guerra
REV.	DATA	MOTIVO	DISEGNATO	CONTROLLATO	APPROVATO

COMMO S.p.A.			S. Giovanni Lupatoto VERONA		
DISEGNATO	Olivo	CONTROLLATO	Dalla Verde	APPROVATO	Guerra
MACCHINA	Abila 42-52		CODICE		
GRUPPO	Impianto Elettrico		N° DISEGNO		
OGGETTO	Distinta cavi		24.51.03		
			DATA REVISIONE 0 04/10/2001		

# BETCO US WARRANTY POLICY

## 10 year coverage

Subject to the conditions stated below, Betco warrants parts and labor on rotationally molded polyethylene tanks/housings and injection molded vacuum head assemblies to be free from defects in materials and workmanship for a period of ten years to the original purchaser.

## 3 Year Coverage

Subject to the conditions stated below, Betco warrants parts and labor on all other Betco components to be free from defects in materials and workmanship for a period of three years to the original purchaser.

## 1 Year Coverage

Subject to the conditions stated below, Betco offers a limited warranty on parts and labor on the following equipment: parts and accessories to be free from defects in materials and workmanship for a period of one year to the original purchaser.

- DM Series Vacuums: #85506-00, #85507-00
- Bac Pac Lite Vacuum: #85903-00
- FiberPRO® Floor Dryer: #85507-00
- WORKMAN™ Series Vacuums: #85024-00, #85025-00, #85026-00, #85027-00
- CV100T Vacuum: #85023-00
- All Tools and Accessories
- All Battery Chargers
- All Batteries are pro-rated for 1 year

### **Allowable Travel Time Warranty Reimbursement:**

Eligible equipment: All battery and propane powered equipment products. Warranty period: 90 days from date of sale to the original purchaser. A maximum 60 mile round trip at 44 cents per mile will be allowed for warranty consideration.

### **Propane Machine Warranty:**

Honda engines are warranted by Honda for a period of 2 years against manufacturer defects. Kawasaki engines are warranted by Kawasaki for a period of 2 years against manufacturer defects. All other components (except wear items)\* are warranted by Betco for a period of 3 years.

**\*Wear Items exempt from Warranty consideration include but may not be limited to: power cords, transport wheels, vacuum bags, belts, squeegee blades, pad drivers, clutch plates, handle grips, filters, screens, throttle cables, brushes and carbon brushes.**

Subject to the conditions and exceptions stated in this warranty, Betco warrants the Betco products to be free from defects in material and workmanship, under normal use and service, for the periods listed under the warranty policy to the original purchaser. At any time during the warranty period, Betco will furnish replacement parts for the Betco parts to the original purchaser. Such parts will be furnished and charged including transportation costs, to the original owner through any Betco authorized Service Distributor. If the original part is returned within the warranty policy period from date of delivery for inspection by Betco and is found to be defective the owner will be credited for the cost of replacement parts plus shipping and handling. Replacement parts that have become defective through wear or abuse are not included in this warranty.

This warranty does not apply to damage or defect caused by accident, misuse, negligence, fire, or to any Betco product which has been serviced or repaired by other than an authorized Betco Service Distributor or Betco factory personnel. This warranty is void if products are used for any purpose other than that which was intended. There are no other warranties expressed or implied. In no event shall Betco be liable for incidental or consequential damages or any damage to person or property. (Please note some states do not allow the exclusion or limitations for incidental and consequential damages)

