



Electronic Service Manuals

This electronic document is provided as a service to our customers. We do not create the contents of the information contained in this document. Should you have detailed questions pertaining to the information contained in this document, you may contact Michco, or the manufacturer which provided the original information in this electronic deliverable. Michco's only part in this electronic deliverable was the electronic assembly process. By providing this manual online we are not guaranteeing parts availability.

You may contact Michco through the following methods:

Phone (517) 484-9312

2011 N. High St. -- Lansing, Michigan -- 48906

Fax: (517) 484-9836

Email: CustomerService@Michco.com

Website: www.Michco.Com

Order Parts online at:

www.Michco.Com

Directly to Parts & Service:

By Email: **CustomerService@Michco.com**

By Fax: (517) 484-9836

By Voice: (517) 484-9312

Serving the Cleaning Industry Since 1922

Notice: All copyrighted material remains property of original owners, all trademarks are property of respective owners. Manuals are subject to Manufacturer's reproduction limitations. Originals or reproductions were provided by manufacturers through a request. We make no warranty as to the correctness of information provided in this document and you assume all risk. By placing these manuals on line we are not declaring our corporation to be an manufacturer authorized dealer or provider, please check our web site for authorized manufacturers we represent.



E89606-00 E89770-00
E89769-00



STEALTH™ AS020BT

20" Automatic Scrubber
with Traction Drive



Operator and Parts
Manual

TABLE OF CONTENTS

RECEIVING THE MACHINE.....	3 - 4
GENERAL SAFETY REGULATIONS	5
MACHINE PREPARATION.....	6 - 13
OPERATION	14 - 15
SHUTTING DOWN THE MACHINE.....	16
DAILY MAINTENANCE.....	17 -18
WEEKLY MAINTENANCE.....	19
TROUBLESHOOTING	20
PAD SELECTION AND USE.....	20
MAINTENANCE SCHEDULE.....	21
WEAR ITEMS LISTING.....	22
PARTS DIAGRAMS AND LISTINGS.....	24 - 43
ELECTRICAL SYSTEM.....	44 - 45
BATTERY CHECK CARD – HOUR METER.....	46
SOLUTION TANK INSPECTIONS	47
VACUUM SYSTEM INSPECTION	47
BRAKE ADJUSTMENT.....	48
SQUEEGEE ADJUSTMENT	48
CHECK LIST	49
WARRANTY	52

RECEIVING THE MACHINE

Immediately check, when receiving the machine, that all the materials indicated on delivery documents have been received and also that the machine has not been damaged in transit. If it has been damaged, this damage must be immediately reported to the shipper and also to our customer's service department. Only acting promptly in this manner will make it possible to receive missing material and to be compensated for damage. If it has been damaged, this damage must be immediately reported to the shipper and also to our customer's service department or a claim may not be made.

INTRODUCTION

This is an automatic scrubber which, via the mechanical action of the oscillating pad and the chemical action of a water/detergent solution, can clean and strip many types of hard flooring. As it advances, it also collects the dirt removed and the detergent solution not absorbed by the floor.

Only use this machine for its intended purpose. Please keep the machine in good working order by performing routine maintenance. Read this instruction manual and refer back to it when machine questions arise. Our technical customer service representatives should be contacted when machine questions are not answered by this manual.

Serial # Plate

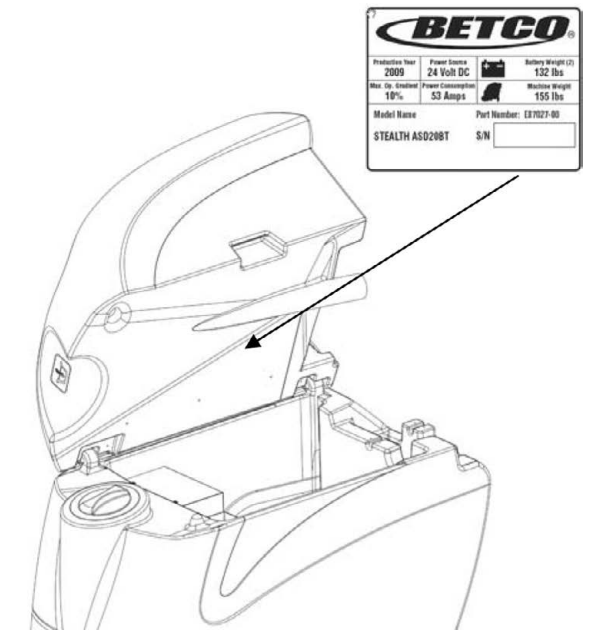

SYMBOLS USED ON THE MACHINE

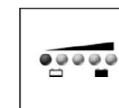

Battery charge gauge

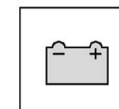

Battery symbol

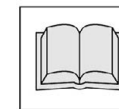

Open book symbol

Used to tell the operator to read the manual before using the machine



Maximum solution temperature gauge

Located near the solution tank inlet

GENERAL SAFETY REGULATIONS

TECHNICAL DESCRIPTION	Measurement Unit	Stealth™ AS020BT
Rated power	HP (W)	1.44 (1074)
Working width	In (mm)	20 (508)
Rear squeegee width	In (mm)	30 (762)
Work capacity	ft ² /h (m ² /h)	20,000 (1,858)
Water consumption	g/m ²	38
Pad (width)	in (mm)	20 (508)
Motor RPM	RPM	2,000
Pad pressure	lb. (Kg)	110 (50)
Deck motor	V / HP (V / W)	24 / 0.91 (24 / 680)
Drive Type		Automatic
Traction motor	V / HP (V / W)	24 / 0.20 (24 / 400)
Forward movement speed	mph (km/h)	2.5 (4)
Maximum grade		10%
Vacuum motor	V / HP (V / W)	24 / 0.42 (24 / 310)
Vacuum motor suction	inches of water (mbar)	75.6 (188)
Solution tank capacity	Gal (l)	10.5 (40)
Recovery tank capacity	Gal (l)	13 (50)
Weight of machine (excluding batteries)	lb. (Kg)	285 (129)
Batteries	V / Ah	12 / 130 (2)
Charger	V / A	24 / 12
Battery compartment dimensions (Length / Height / Width)	in x in x in (mm/mm/mm)	14.2 x 12.8 x 13.0 (360 / 325 / 330)
Machine dimensions (Length / Height / Width)	in x in x in (mm/mm/mm)	43 x 39 x 21 (1090 / 990 / 530)
Noise level	dBA	64 / 62 Eco Mode

The regulations below must be carefully followed in order to avoid harm to the operator and damage to the machine.

- Read all labels on the machine carefully. Do not cover them for any reason and replace them immediately if they become damaged.
- The machine must be used exclusively by authorized and trained personnel.
- When operating the machine be careful of other people.
- The machine is not designed for cleaning carpets.
- The power cable outlet must be provided with a proper ground.
- Avoid damaging the power cable of the battery charger by crushing, bending, cutting or stressing it.
- Whenever the power cable of the battery charger is damaged, immediately contact a BETCO service center.
- Do not mix different types of detergent as this may produce harmful gases.
- Do not set containers on the machine.
- Machine storage temperature is between -10°F and 130°F, never store outside under humid conditions.
- Operating conditions: room temperature between 33°F and 100°F with relative humidity between 30% to 95%.
- Only use the machine in closed areas and do not expose it directly to rain.
- Never use the machine in an explosive environment.
- Do not use the machine as a means of transport.
- Never use acidic chemicals which could damage the machine.
- Avoid running the brushes with the machine stopped; this could damage the floor.
- Never vacuum up flammable liquids.
- Never use the machine to gather dangerous powders.
- Use a powder fire extinguisher in case of fire. Do not use water.
- Do not hit against shelving or scaffolding. The operator must always be equipped with the appropriate safety device (gloves, shoes, helmet, glasses, etc.)
- Do not use the machine on surfaces with an inclination greater than the one shown on the serial plate.
- The machine is designed to wash and dry floors simultaneously. Signal the presence of wet floors with suitable signs.
- If the machine does not work properly, perform routine maintenance. Otherwise, request the assistance of the BETCO technical service.
- When replacing parts ask for ORIGINAL spare parts from your Authorized BETCO Dealer and/or Retailer.
- Always turn off the machine and disconnect the battery connector whenever maintenance is performed.
- Never remove guards that require tools for removal.
- **Never wash the machine with direct or pressurized jets of water or with corrosive substances.**
- Have your BETCO service center check the machine once a year.
- To prevent the formation of scale in the solution tank filter, do not store the machine with detergent solution in the tanks.
- Before using the machine make sure that all doors and covers are positioned as shown in this operating and maintenance manual.
- When your BETCO machine is ready to be retired, the machine must be disposed of properly. It contains oils and electronic components. The machine was built using totally recyclable materials.
- Use only pads furnished with the machine or those specified in the user's manual. Use of other pads can compromise safety.
- When removing the battery, unplug the battery connection, unplug the charger and disconnect the battery terminals.
- Before recycling the machine, remove the battery.

MACHINE PREPARATION

1. HANDLING THE PACKED MACHINE

The machine is contained in specific packaging.
It is not possible to place more than two packages on top of each other.
The total weight, as shipped with batteries, is 481 lb. (218 kg).
The overall dimensions of the package are:
A : 45.1 in (1145 mm)
B : 26.2 in (665 mm)
C : 48.4 in (1230 mm)

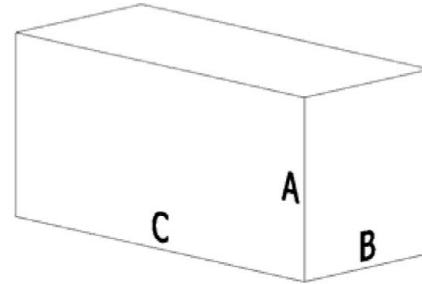

2. HOW TO UNPACK THE MACHINE

- Remove the outer packaging.
- Remove the key (1) from the ignition to prevent damage.
- The machine is fixed to the pallet with wedges (2) which lock the wheels. Remove these wedges.
- Disengage the parking brake (3) by rotating the lever until the brake is no longer in contact with the wheel.

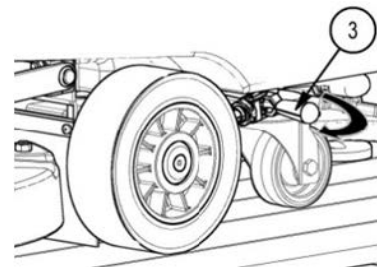

- Use a ramp to get the machine down from the pallet, pushing it backwards.
- Keep the pallet for any future transport needs.

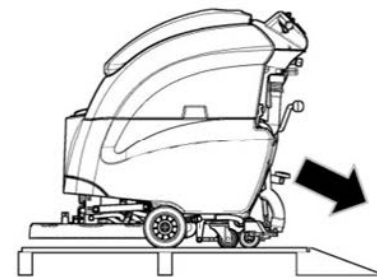

MACHINE PREPARATION

3. BATTERY INSTALLATION

The machine will be supplied with a battery charger and either two 12V Wet or AGM batteries. The batteries must be housed in the battery tray in the battery compartment beneath the recovery tank.
To insert the batteries you must:
A. Lower the squeegee and brush deck.
B. Open the rear latch that secures the recovery tank (2).
C. Rotate the recovery tank as far as it will go, using the side handle (3).

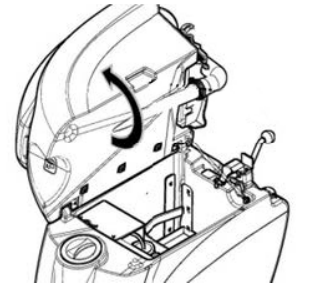

WARNING: To avoid acid leakage you can use sealed batteries.

WARNING: Perform one battery charging cycle before using the machine.

4. TYPE OF BATTERY

To power the machine you can use:

- Wet batteries
- AGM batteries
- Gel batteries

OTHER TYPES MUST NOT BE USED.

The maximum dimensions and the weight are:

Width 6.7 in (171 mm)
Length 12.9 in (329 mm)
Height 9.6 in (245 mm)
Weight 68 lb. (31 kg)



WARNING: Your charger must be set according to the type of battery you install. Call BETCO customer service to ensure correct charger setting after replacement batteries are installed.

- The batteries must be handled using lifting and transportation means suitable for the weight and dimensions.
- They must be lifted by the handles on the upper part.
- They must be connected together in series, to obtain an overall voltage of 24V on the lugs.
- The electrical connection operations must be carried out by certified trained personnel.

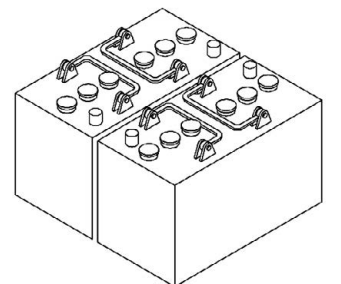
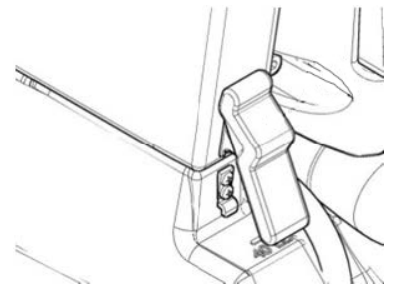

MACHINE PREPARATION

5. BATTERY MAINTENANCE

For maintenance and recharging, follow the instructions provided by the battery manufacturer.

6. BATTERY DISPOSAL

When the battery reaches the end of its working life, it must be disconnected by certified professional, and removed from the battery compartment.

7. CONNECTING THE BATTERY CHARGER

Beneath the recovery tank there is the battery connector (7), the battery charger connector must be plugged into. Disconnect the battery plug and plug the charger into the machine plug.



WARNING: This process must be carried out by qualified personnel. The incorrect or imperfect connection of the cables to the connector can seriously harm people and damage objects.

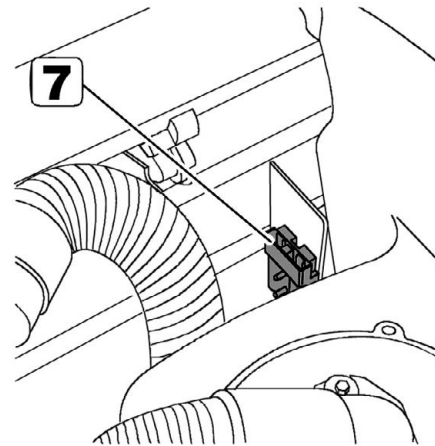

8. RECHARGING THE BATTERIES

Perform one complete battery charge cycle before using the machine. Avoid totally discharging the batteries! This can cause permanent damage to them. Recharge as soon as the battery discharged signal light starts to flash.



WARNING: Never leave the batteries completely discharged, not even if the machine is not being used. This can cause permanent damage to them. While recharging, keep the recovery tank raised. Ensure the battery charger is suitable for the batteries installed.



Danger of inhalation of gas and leakage of corrosive liquids.



Danger of fire: do not go near flames.

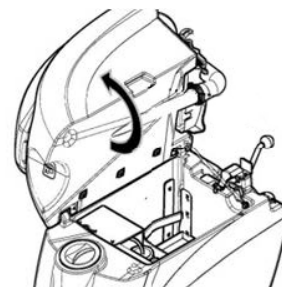

MACHINE PREPARATION

9. CONNECTING THE BATTERY CONNECTOR

Connect the battery connector (2) to the machine connector (1)

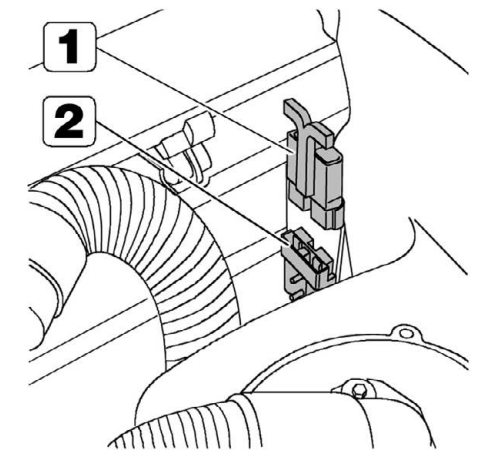

10. BATTERY INDICATOR

The battery indicator uses LEDs and has 8 positions (7 yellow - charged batteries, and 1 red - run down batteries).



WARNING: A few seconds after the red indicator light comes on, the brush motor switches off automatically. With the remaining charge it is possible to complete the drying process before recharging.

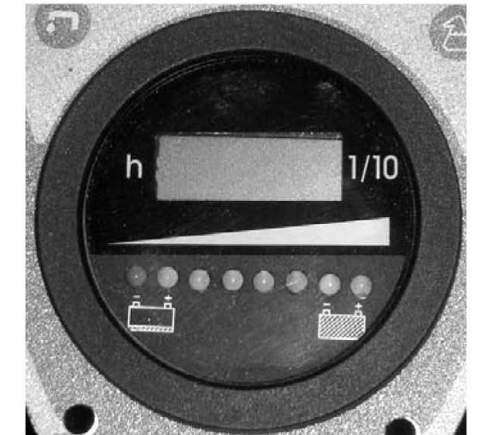

MACHINE PREPARATION

11. INSTRUMENT PANEL COMPONENTS

The instrument panel components are identified as follows:

1. Levers to activate pad / traction (located beneath the handlebar)
2. ON/OFF key switch
3. Battery level / hour-counter display
4. Traction speed control knob
5. Eco-mode button

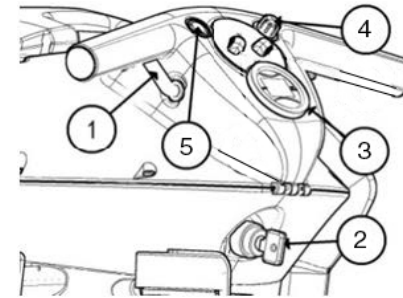

12. REAR COMPONENTS

The rear components are identified as follows:

6. Foot pedal to raise the brushes
7. Water / solution level hose
8. Drain hose with recovery tank cap
9. Latch to close the tanks
10. Compartment storage
11. Lever to raise the squeegee
12. Solution filter
13. Solution control valve

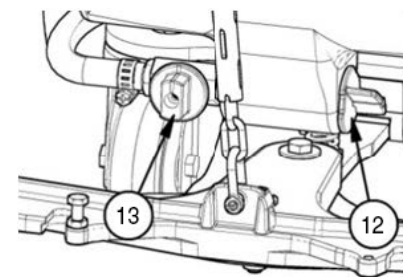
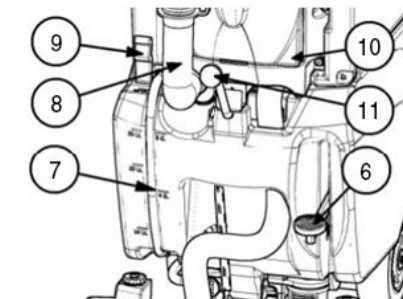

13. SIDE COMPONENTS

The side components are identified as follows:

14. Handle to raise the recovery tank
15. Parking brake lever
16. Handle to raise the vacuum unit
17. Upper storage compartment
18. Solution tank fill inlet

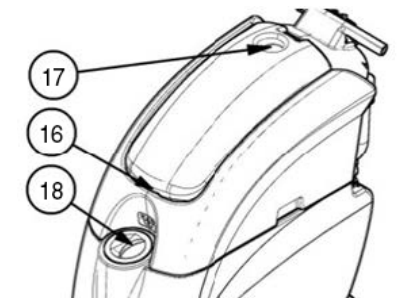
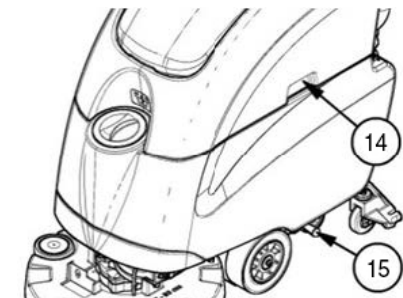

14. ASSEMBLING THE SQUEEGEE

For packaging reasons, the squeegee is supplied dismantled from the machine, and must be assembled as follows:

- Insert the two small pins of the squeegee in the appropriate holes on the squeegee yoke.
- Insert the two cotter pins chained to the squeegee shoe.
- Attach the squeegee vacuum hose over the squeegee shoe adapter.

14. ASSEMBLING THE SQUEEGEE

For packaging reasons, the squeegee is supplied dismantled from the machine, and must be assembled as follows:

1. Close the recovery tank
2. Secure the recovery tank with the latch
3. Loosen the knobs (3) on the squeegee body
4. Insert the left squeegee pin into the left slot (4), tighten the knob (3), ensuring that the washer (5) and spring are on the upper part of the squeegee body.
4. Insert the right squeegee pin into the right slot (6), tighten the knob (3), ensuring that the washer (7) and spring are on the upper part of the squeegee body.
5. Insert the vacuum hose (8) onto the the squeegee vacuum port (9).

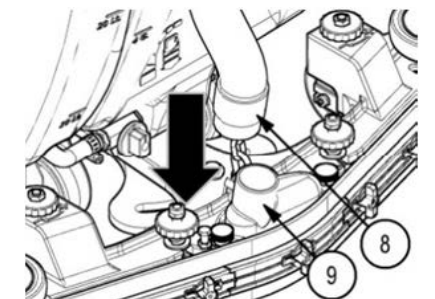
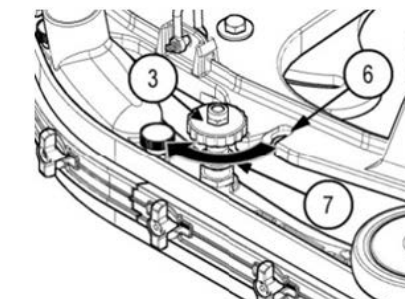
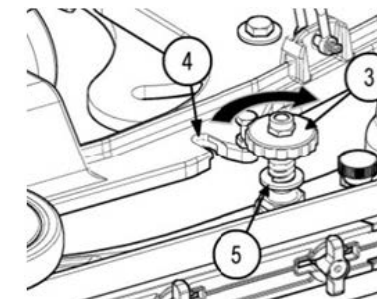
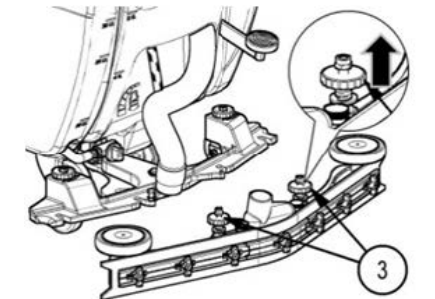
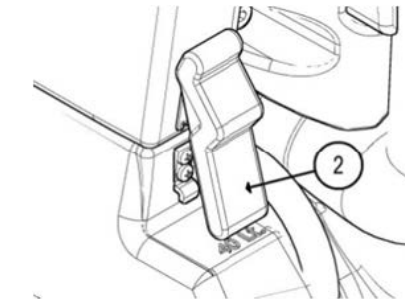
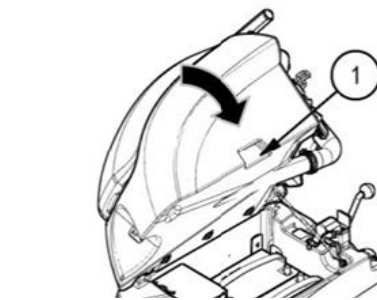

15. ADJUSTING THE SQUEEGEE HEIGHT

The height of the squeegee must be adjusted based on wear of the squeegee blade. To do this, turn the knobs counter clockwise to raise the squeegee, and clockwise to lower it.

Note: The right and left wheels must be adjusted to the same level, so the squeegee can work parallel to the floor.

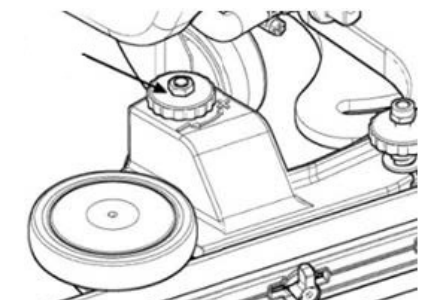

MACHINE PREPARATION

16. ADJUSTING THE SQUEEGEE INCLINATION

During operation, the rear squeegee blade is slightly tilted backwards (by about 0.2 in. (5 mm) in a uniform way over entire length. If it is necessary to increase the bend of the squeegee blade in the center, you must tilt the squeegee backwards, rotating the adjuster clockwise. To increase the bend of the squeegee blade at the outside edges of the squeegee, rotate the adjuster counterclockwise. When fully adjusted, tighten the jam nut.

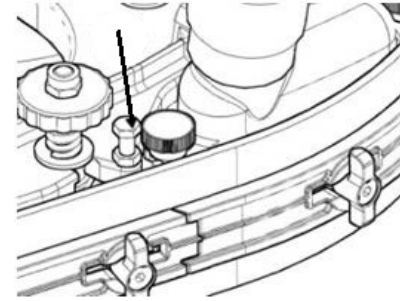

17. RECOVERY TANK

Check the drain hose cap (on the rear of the machine) to ensure it's closed.

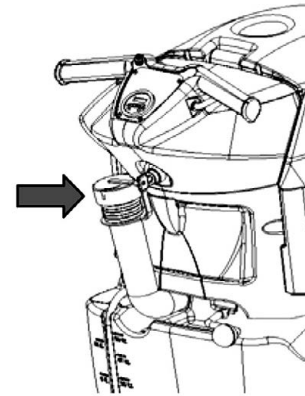

18. SOLUTION TANK

Remove the front inlet cap and check the solution filter is correctly installed. Check the filter cap (beneath the solution tank, at the back) is correctly closed.

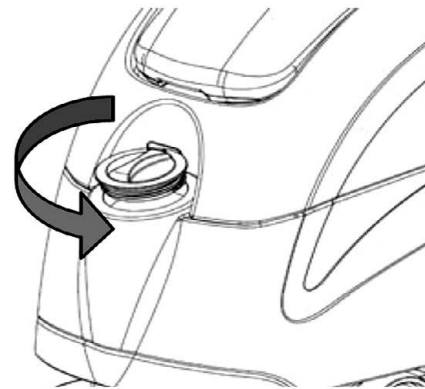

19. SOLUTION TANK

Fill the tank with clean water in the front fill location (1) at a temperature not exceeding 120°F (50°C). You can check the level of solution in the tank by means of the rear hose (2).

Add liquid detergent into the tank, in the concentration and manner specified by the manufacturer. The formation of excess foam could damage the vacuum motor, so be sure to use only the correct amount of detergent.



WARNING: Always use low-foam detergent. Introduce a small amount of defoaming liquid in the recovery tank before starting work to prevent foam from being generated.

WARNING: Never use pure acids.

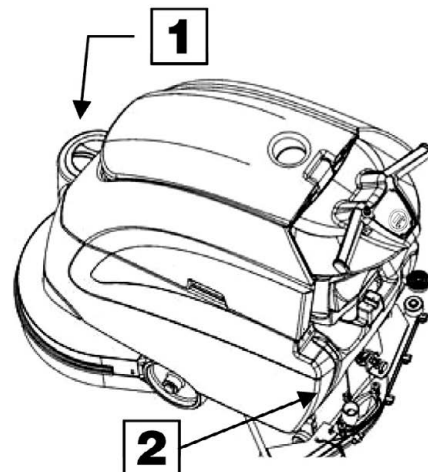

MACHINE PREPARATION

20. PAD INSTALLATION

- Raise the deck and remove any pad or debris from the pad locking face.
- Line up a new red pad with the pad driving plate and push up lightly to install.
- Lower the deck to complete the installation.
- When using a screen, abrasive pad, or any pad less than 1/2" thick, place it on the ground below the red pad before lowering the deck.



WARNING: Never operate the machine without a red backing pad. Failure to use a red backing pad will cause damage to the floor and the machine.

OPERATION

1. MACHINE OPERATION

A. Connect the battery plug to the machine plug.

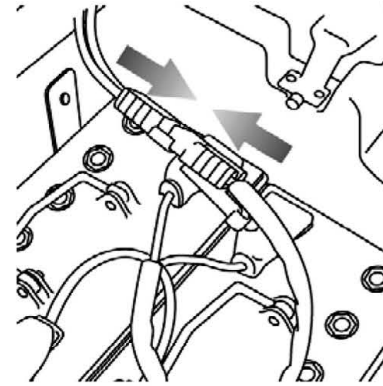

B. Turn the key (1) of the main switch to the "ON" position (clockwise). The battery charge level indicator lights will immediately come on.

C. Turn on the water valve (2) (the water dispenses automatically when the pad is oscillating).

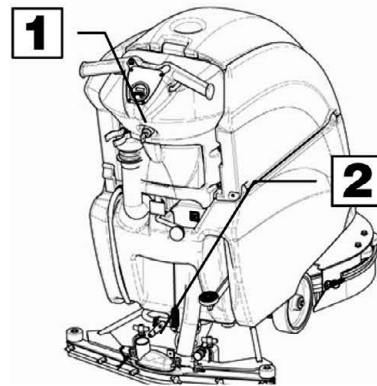

D. Release the foot lever (3) and lower the pad deck.

E. Lower the squeegee by rotating the squeegee lift handle (4) counter clockwise. The vacuum motor will turn on.

F. Check that the brake (5) is released.

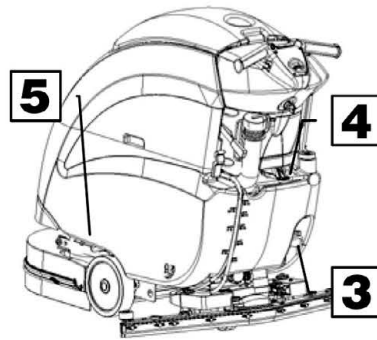

G. Pulling the switch levers (1), activates the pad and the machine begins to move. During the first few feet, check that the amount of solution dispensed is correct, and that the squeegee dries the floor.

H. The machine will now start to scrub and dry until the solution tank is empty or recovery tank is full.

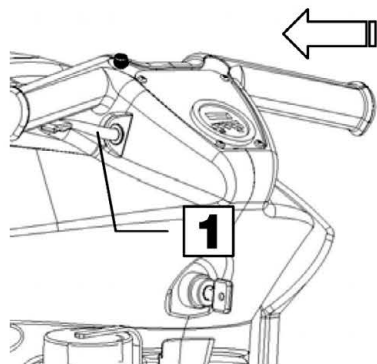

OPERATION

2. REVERSE MOVEMENT

To move the machine in reverse push the switch levers (1) forward.



WARNING: When moving the machine in reverse, raise the squeegee.

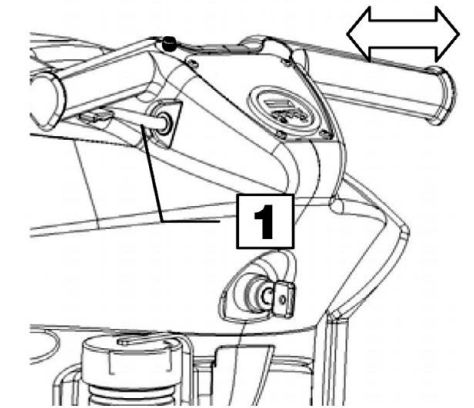

3. OVERFLOW DEVICE

The machine has a float in a filter basket that trips when the recovery tank is full to stop airflow into the vacuum hose.

At this point empty the recovery tank by removing the cap of the drain hose.



WARNING: Always wear gloves when doing this operation to protect yourself from contact with hazardous chemicals.

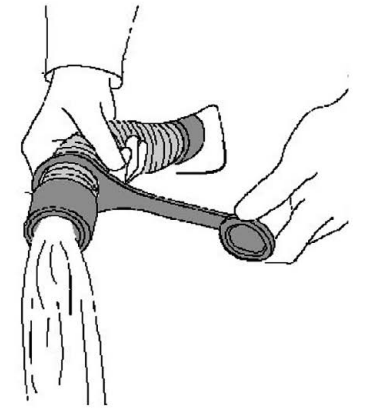

SHUTTING DOWN THE MACHINE

1. END OF WORK

When shutting down the machine and before you perform any type of maintenance:

- A. Turn off the solution control valve (1)
- B. Raise the pad deck using the foot pedal (2)
- C. Raise the squeegee using the squeegee lift lever (3)
- D. Turn off the key switch (4)
- E. Move the machine where the tanks can be drained.

- F. Remove the drain hose from it's hook, remove the drain cap and empty the recovery tank.
- G. The squeegee must be raised when the machine is not operating, to avoid deforming the squeegee blades.
- H. Remove any used pads and clean them with water.

 **WARNING: Always wear gloves when doing this operation to protect yourself from contact with hazardous chemicals.**

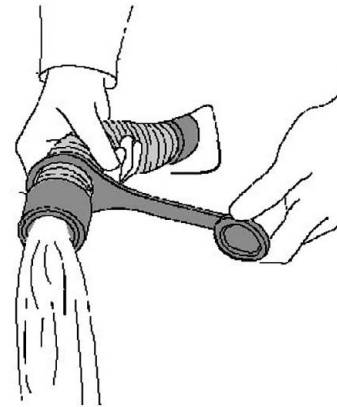
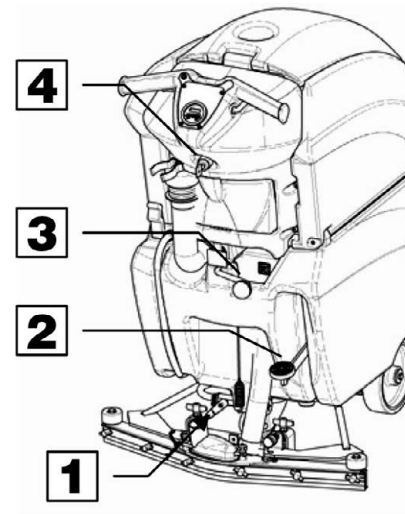

DAILY MAINTENANCE

1. CLEANING THE RECOVERY TANK

- A. Raise the vacuum cover (1).
- B. Remove the drain hose (2) from it's hook and empty the tank.
- C. Rinse the inside of the tank with water.
- D. Close the cover on the machine and replace the drain hose cap and drain hose.

 **WARNING: Always wear gloves when doing this operation to protect yourself from contact with hazardous chemicals.**

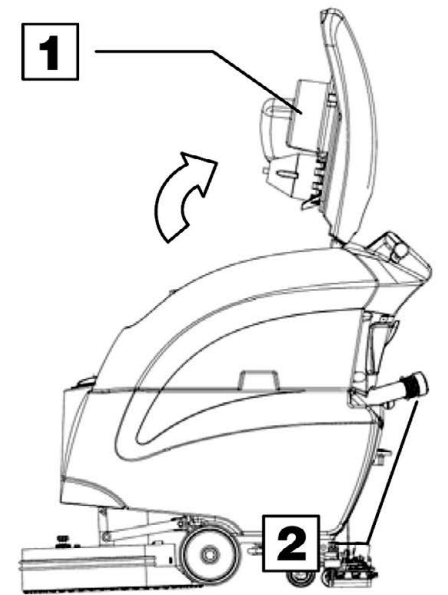

2. CLEANING THE VACUUM FILTER

- A. Raise the cover.
- B. Remove the vacuum filter cover by rotating it clockwise.
- C. Pull the filter straight down from the lid to remove it.
- D. Use water to clean the walls and base of the filter.
- E. Reassemble all the components.

 **WARNING: Always wear gloves when doing this operation to protect yourself from contact with hazardous chemicals.**

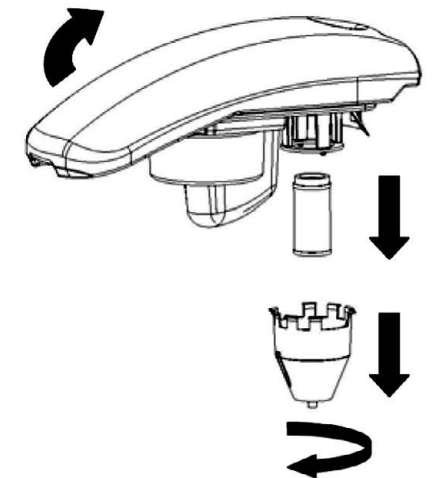

DAILY MAINTENANCE

3. CLEANING THE SQUEEGEE

To clean:

- Take the machine to a safe location on flat ground and ensure that the device is in a safe condition.
- Close the lid using the handle (1).
- Secure the recovery tank latch (2).
- Remove the vacuum hose (3) from the vacuum hose port (4).
- Loosen the knobs (5) from the squeegee assembly and remove it from the machine.
- Using a hose and cloth, thoroughly clean the squeegee assembly body (6).
- Using a hose and cloth, thoroughly clean the front squeegee blade (7) and the rear squeegee blade (8).
- Inspect the squeegee blades and replace them if the edges are worn.
- Remove the vacuum hose port knobs (9) and clean inside the vacuum hose port (4) including the mating face on the squeegee assembly.



WARNING: Always wear gloves when doing this operation to protect yourself from contact with hazardous chemicals.

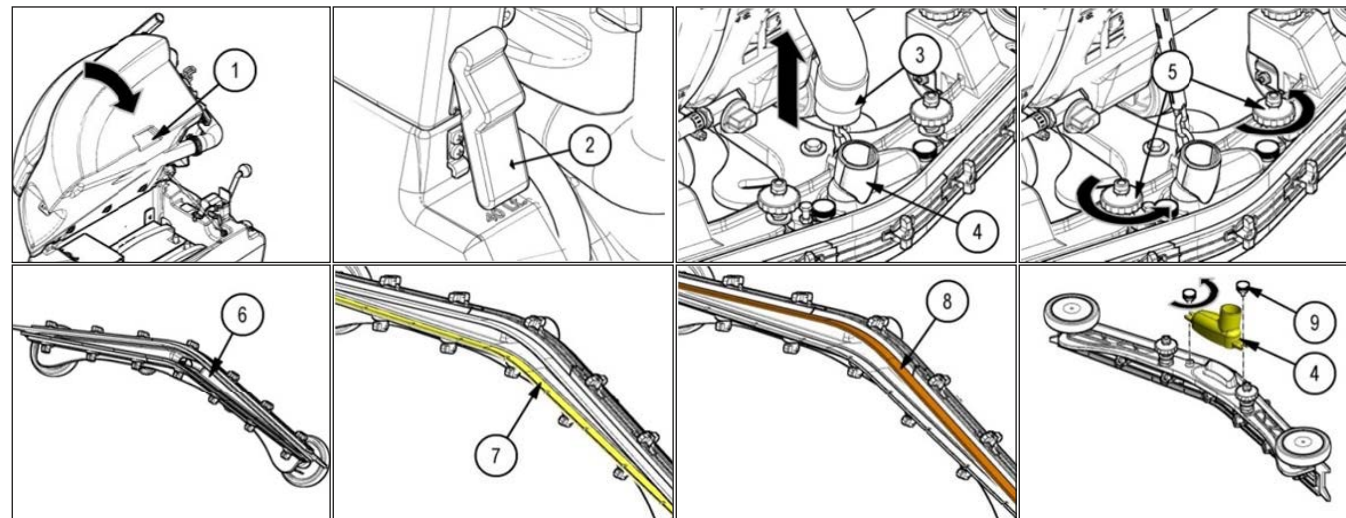

4. REPLACING THE SQUEEGEE BLADES

Check the wear of the squeegee blades and, if necessary, replace them.

To replace them:

- Follow the instructions in "Cleaning the Squeegee" section to remove the squeegee assembly.
- Turn the wing nuts (1) that hold the front squeegee pressing blades (2) on the squeegee assembly.
- Remove the front squeegee pressing blades (2) and the front squeegee (3) from the assembly.
- Turn the wing nuts (4) that hold the rear squeegee pressing blades (5) on the squeegee assembly.
- Remove the rear squeegee pressing blades (5) and the rear squeegee (6) from the assembly.
- Reverse these instructions to reinstall the new squeegee blades.



WARNING: Always wear gloves when doing this operation to protect yourself from contact with hazardous chemicals.

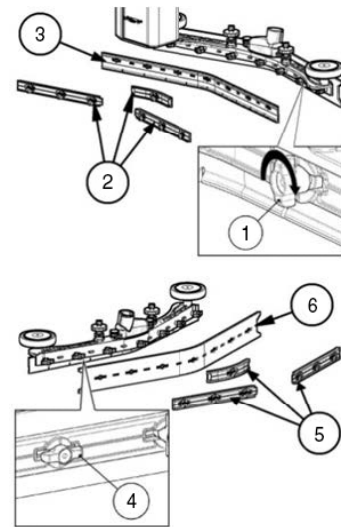

WEEKLY MAINTENANCE

1. CLEANING THE SQUEEGEE HOSE

Every week, or whenever vacuum seems to be unsatisfactory, check the squeegee hose for obstructions. To clean it:

- Remove the vacuum hose from the squeegee shoe adapter on the squeegee shoe.
- Wash the inside of the hose with water.
- Drain and clean the recovery tank after cleaning the hose.
- Reassemble the hose.



WARNING: Always wear gloves when doing this operation to protect yourself from contact with hazardous chemicals.

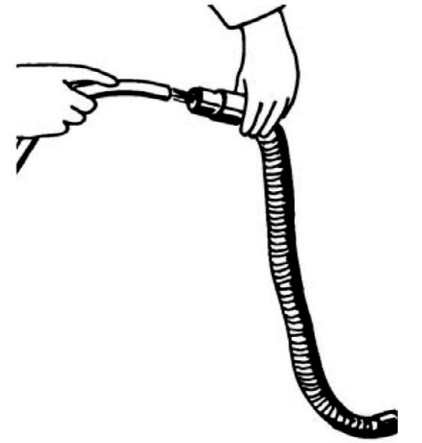

2. CHECKING THE BRAKE

Every week, check the distance between the work brake pads and the wheels. If necessary, adjust so they are at a distance of 0.12 in (3 mm) when released.

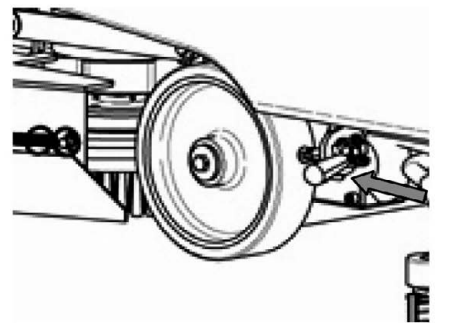

3. CLEANING THE SOLUTION TANK

- Remove the solution tank cap.
- Rinse with water.
- Remove the drain cap (1) located on the filter, and empty the tank.



WARNING: Always wear gloves when doing this operation to protect yourself from contact with hazardous chemicals.

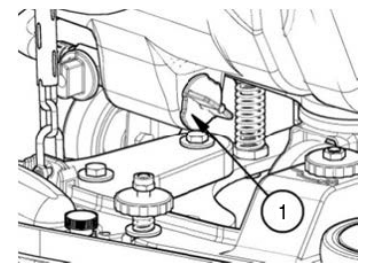

TROUBLESHOOTING GUIDE

INSUFFICIENT WATER ON THE PAD

1. Check water level in solution tank (1).
2. Check that the solution control valve (2) is rotated to the left.
3. Clean the solution tank filter (3) and inspect for blockages.

THE MACHINE DOES NOT CLEAN WELL

1. Check the wear of the scrubbing pad and, if necessary, replace it.

THE SQUEEGEE DOES NOT DRY WELL

1. Check that the squeegee blades are clean.
2. Adjust the inclination of the squeegee.
3. Ensure the vacuum hose is correctly inserted in its housing in the recovery tank.
4. Disassemble the entire vacuum unit and clean it.
5. Replace the squeegee blades, if worn.
6. Check squeegee wheel adjustment.

TOO MUCH FOAM IS GENERATED

Check that low-foam detergent is being used. If necessary add a small amount of de-foamer liquid to the recovery tank. Remember that more foam is generated when the floors are not very dirty. Dilute the detergent more when cleaning floors that are not very dirty.



CHOOSING AND USING THE PADS

RED SCRUBBING PAD - E89831

Used for general cleaning and scrubbing. It is capable of removing soil from the top of most hard surfaces. This pad is also used to drive maroon pads and must be placed between the pad driver and maroon pad to avoid damage to the floor or the machine.

MAROON STRIPPING PAD - E84057

The recommended pad for removing finishes from hard floors. It is also proficient at removing heavy soil and scuffs from concrete and epoxy coated floors. This pad must be used with a red pad between it and the pad driver.

GREEN TILE AND GROUT PAD - E84073

Used to clean tile floors, terrazzo, textured floors, and concrete.

WHITE POLISH PAD

Removes light soil and scuff marks from softer finishes. This pad is similar to the red pad but is less aggressive and will not dull softer finishes such as wood floors.

MAINTENANCE SCHEDULE						
	Stealth ASDO20B	DAILY	RECOMMENDED SERVICE INTERVALS (HOURS)			
			50	100	200	400
BATTERIES	Check water level - add if necessary	DAILY				
	Check cables, connections and plugs		50			1,800
	Check cleanliness of machine battery tray				200	
ELECTRIC	Check tightness of electric contacts and fuses		50			
	Check state of electric cables crossing the machine					400
SOLUTION TANK	Check cleanliness of the tank	DAILY				400
	Check water valves and hoses to the deck		50			
	Check all water connections from the tank to the deck				200	
RECOVERY TANK	Check cleanliness of the tank	DAILY				
	Check filter and float system	DAILY				
	Check vacuum and drain hoses	DAILY				1,800
	Check vacuum gasket and drain hose plugs			100		
ORBITAL HEAD	Check state of bearing and isolators					400 1,500
	Check pad locking face				200	
	Check wear of pad	DAILY	50		X	
DECK MOTOR	Check cleanliness of air cooling inlet			100		
	Check carbon brushes					400 1,800
	Check amp draw and noise level					1,000
VACUUM MOTOR	Check noise level and cleanliness of the inlet hose		50			
	Check carbon brushes				200	400
	Check vacuum performance, replace if necessary					1,800
SQUEEGEE	Check cleanliness of the squeegee blades and shoe	DAILY				
	Check wear of rear squeegee blade		50	100		
	Check wear of front squeegee blade			100	200	
	Check squeegee structure and machine support			100		
	Check lever and lifting cable					400

Suggested replacement 

WEAR ITEMS LISTING

Wear Items

Part #	Description
E20060	Pad Driver
E20213	Isolator (10 per machine)
E22128	Bearing
E20215	Eccentric
E89831	Red Scrubbing Pad
E84057	Maroon Stripping Pad
E84073	Green Grout and Tile Pad

Part #	Description
E22637	Squeegee Blade Kit, 31"
E84277	Squeegee Blade Kit, Poly, 31"
E84278	Squeegee Blade Kit, Latex, 31"
E11767	Battery 12V 130AH Wet
E88030	Battery 12V 110AH AGM
E86276	Battery 12V 115AH Wet

ORBITAL DECK DRIVE DIAGRAM

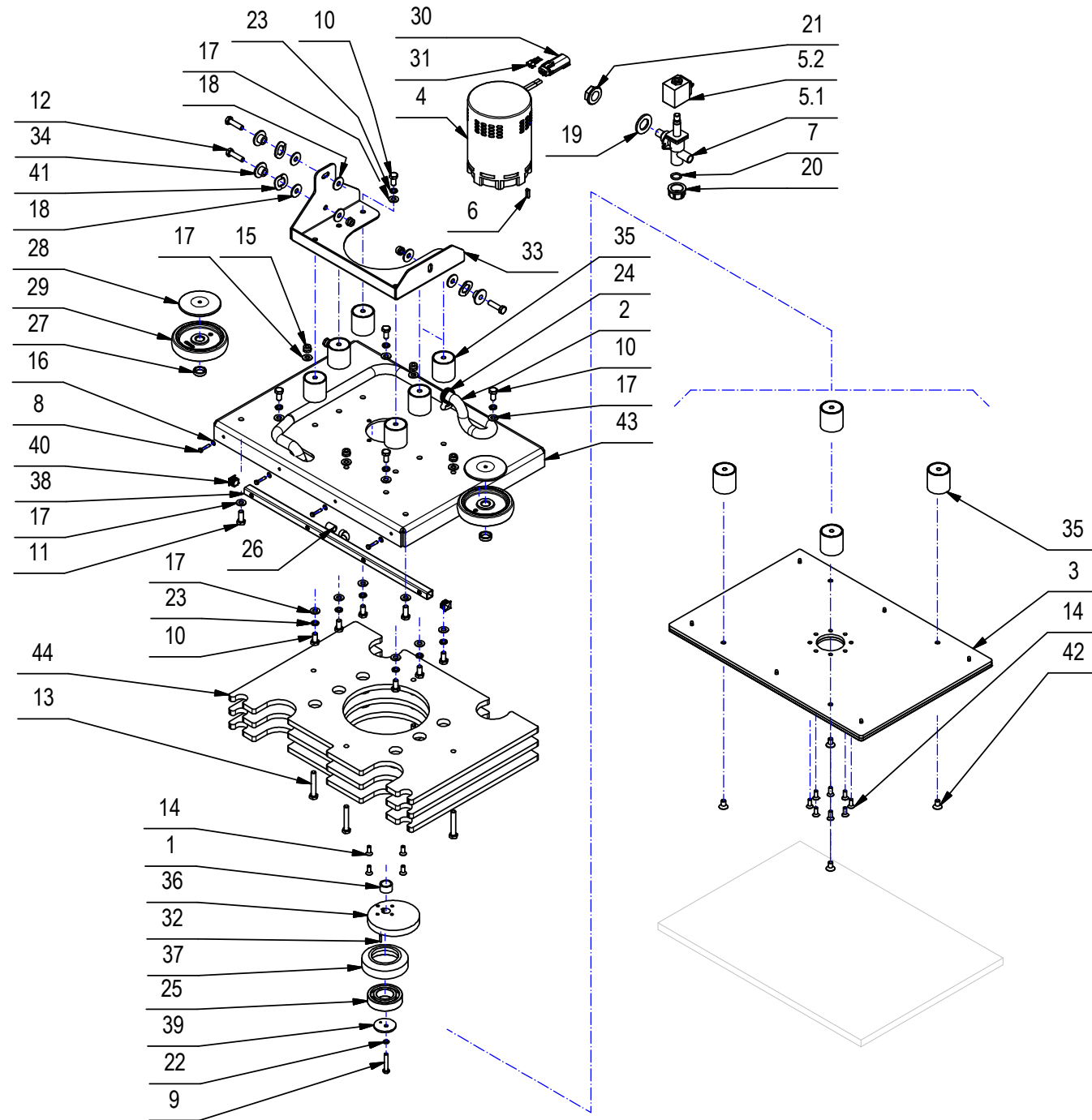

ORBITAL DECK DRIVE PARTS LISTING

Item#	Part #	Description	Qty.	Item#	Part #	Description	Qty.
1	E20001	Spacer, 22 x 17 x 13	1	22	E20323	Washer, Lock, M6, SS	1
2	E20048	Pipe	1	23	E81046	Washer, Lock, M8 x 14.8 x 2, Zinc	16
3	E20060	Pad Driver	1	24	E84264	Clamp, Hose	2
4	E82576	Motor, Brush, 24VDC 400W 2300RPM	1	25	E22128	Bearing, 6206 2RSL/C3	1
5	E82322	Solenoid Valve, 24v 10w 3-Port Nylon	1	26	E20577	Spacer	1
5.1	E81794	Valve Body, Solenoid	1	27	E20116	Spacer, 22 x 17.3 x 6	2
5.2	E81795	Solenoid	1	28	E22646	Cover, Wheel	2
6	E82399	Shaft Key	1	29	E22668	Wheel, Bumper	2
7	E83617	O-Ring, 14 x 2.5mm, Buna-N	1	30	E22641	Connector, Female	1
8	E20082	Screw, M4 x 20	4	31	E84319	Molex Pin	2
9	E22545	Screw	1	32	E20153	Pin, Spring	1
10	E83795	Bolt, Hex, M8 x 16, Zinc	16	33	E20169	Support	1
11	E81917	Bolt, Hex, M8 x 20, Zinc	2	34	E20170	Bushing	3
12	E83802	Bolt, Hex, M8 x 30, Zinc	3	35	E20213	Isolator	10
13	E87285	Bolt, Hex, M8 x 50, Zinc	4	36	E20215	Eccentric	1
14	E22511	Screw, Flat Hd Soc Machine, M6 x 16	12	37	E20263	Bearing Retainer	1
15	E81709	Nut, Nyloc Hex, M8, Zinc	7	38	E20280	Distributor	1
16	E83859	Washer	4	39	E20308	Washer	1
17	E81874	Washer, Flat, M8 x 17 x 1.6, Zinc	22	40	E20344	Cap	2
18	E83404	Washer, Flat, M8 x 24 x 2, Zinc	6	41	E20347	Washer	3
19	E20253	Washer, Flat, M21 x 60 x 3, Zinc	1	42	E20361	Screw, M8 x 14	4
20	E83882	Cap, 1/2" NPT	1	43	E20410	Base	1
21	E20433	Nut, Hex Flange, M20, Plastic	1	44	E20423	Weight	3

SQUEEGEE ASSEMBLY DIAGRAM

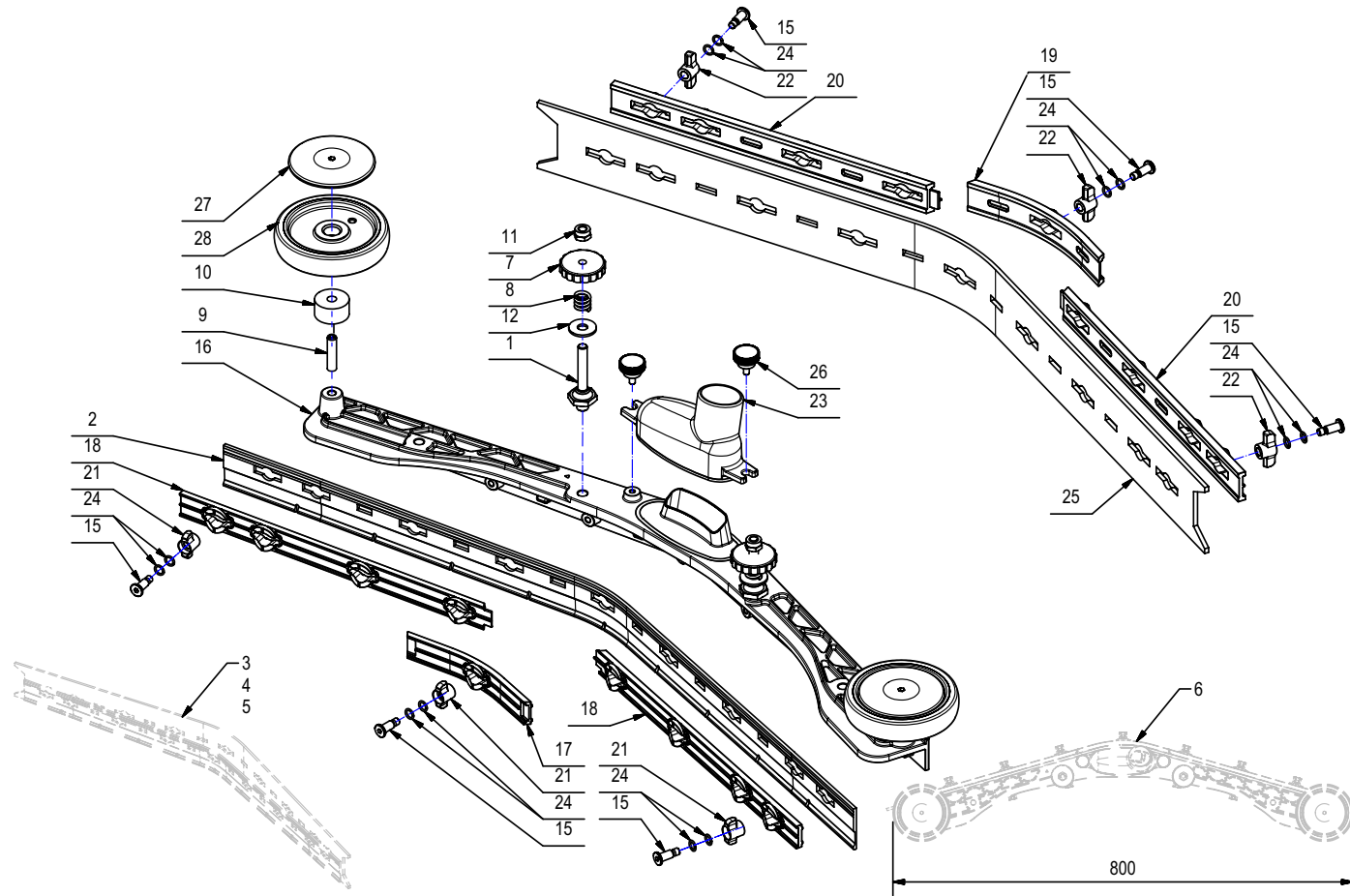

SQUEEGEE ASSEMBLY PARTS LISTING

Item#	Part #	Description	Qty.	Item#	Part #	Description	Qty.
1	E84336	Mounting Stud	2	17	E22352	Center Front Squeegee Blade Clamp	1
3	E22637	Squeegee Blade Kit, 31"	1	18	E22635	Clamp, Front Squeegee Blade	2
4	E84277	Squeegee Blade Kit, Poly, 31"	1	19	E22355	Center Rear Squeegee Blade Clamp	1
5	E84278	Squeegee Blade Kit, Latex, 31"	1	20	E22634	Rear Squeegee Blade Clamp	2
6	E84337	Squeegee Assembly Complete, 31.5"	1	21	E22358	Wing Nut Knob	9
7	E83331	Knob, M8 Round Nylon Female	2	22	E22359	Wing Nut Knob	9
8	E83402	Spring, 15mm O.D. x 11mm I.D. x 16mm L	2	23	E22360	Squeegee Shoe Adapter	1
9	E83804	Stud	2	24	E22385	O-Ring, 7mm	36
10	E84338	Spacer	2	25A	E22637	Squeegee Blade Kit, 31"	1
11	E81342	Nut, Hex Jam, Nyloc, M8 SS	2	25B	E84277	Squeegee Blade Kit, Poly, 31"	1
12	E86164	Flat Washer M9x24x2.5 SS	2	25C	E84278	Squeegee Blade Kit, Latex, 31"	1
15	E22346	Screw, Custom Cap	18	26	E22630	Thumb Screw	2
16	E22633	Squeegee Body	1	27	E22646	Wheel Cover	2
				28	E22668	Bumper Wheel	2

SQUEEGEE YOKE DIAGRAM

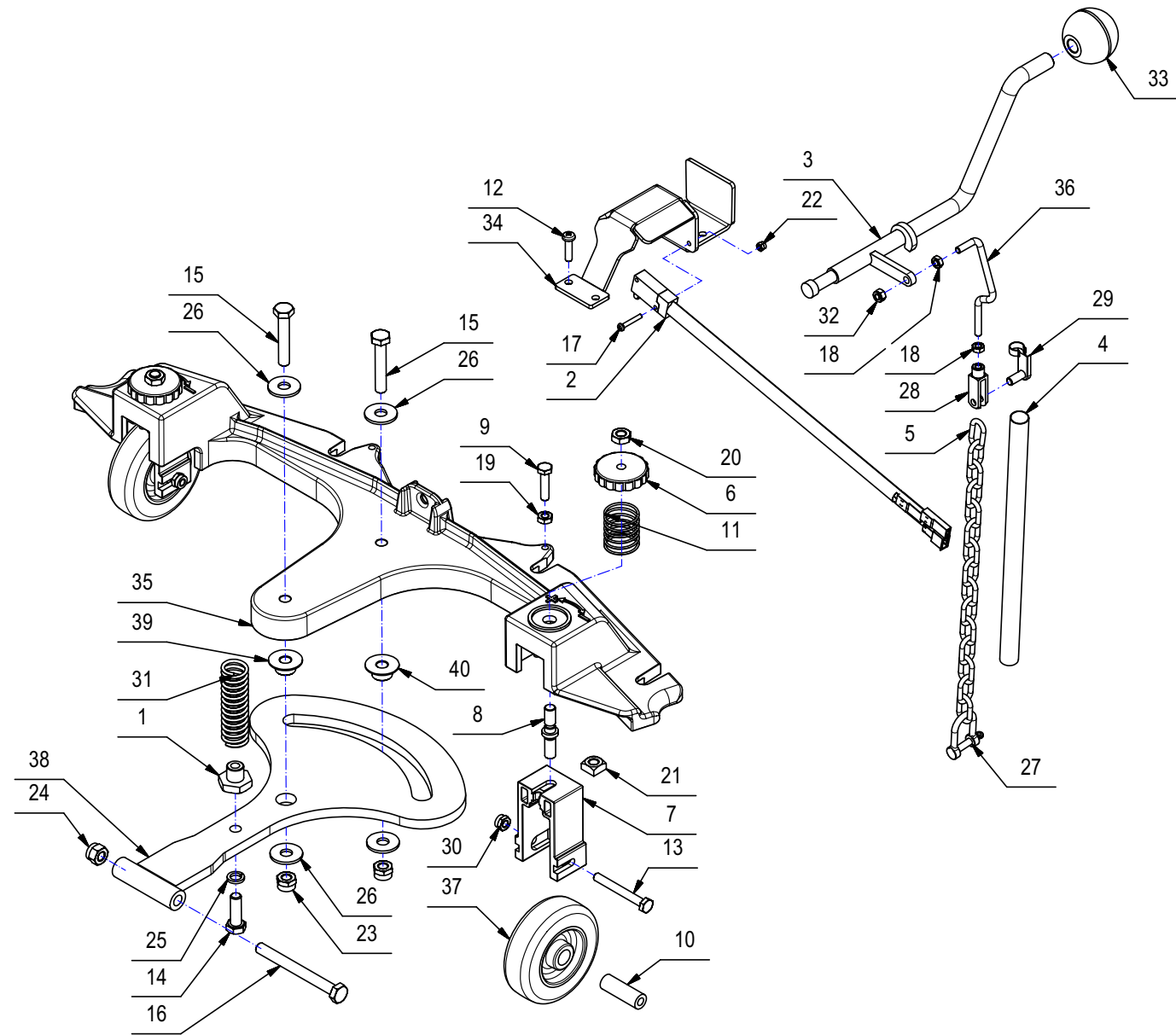

SQUEEGEE YOKE PARTS LISTING

Item#	Part #	Description	Qty.	Item#	Part #	Description	Qty.
1	E20006	Bushing	1	21	E83824	Square Nut, M8 SS	2
2	E88279	Micro Switch Sealed	1	22	E81673	Nut, Hex Nyloc, M3 Zinc	2
3	E20408	Squeegee Lift Lever	1	23	E81342	Nut, Hex Jam, Nyloc, M8 SS	2
4	E84339	Sheath	1	24	E20119	Nyloc Hex Nut, M8 SS	1
5	E84340	Squeegee Lift Chain	1	25	E81046	Lock Washer M8 Zinc	1
6	E83331	Knob, M8 Round Nylon Female	2	26	E86164	Flat Washer M9x24x2.5 SS	4
7	E20078	Squeegee Wheel Support	2	27	E86147	Split Pin	1
8	E20079	Threaded Adjuster Rod	2	28	E83538	Fork	1
9	E22671	Bolt, M6 x 25	1	29	E83542	Clip	1
10	E82274	Bushing	2	30	E82314	Nut, Hex Jam, Nyloc, M6, SS	2
11	E20091	Spring	2	31	E20519	Spring	1
12	E82288	Screw, Pan Hd Phil, Self Tap, M5.2 x 20, Zinc	4	32	E82256	Nyloc Hex Nut, M5x7 Zinc	1
13	E83933	Screw, Tripla Side Squeegee	2	33	E20638	Knob	1
14	E83833	Hex Bolt M8x25 Zinc	1	34	E84341	Cam Guard	1
15	E20287	Hex Bolt M8x45 SS	2	35	E84342	Squeegee Carriage	1
16	E20099	Hex Bolt M8x80 SS	1	36	E84343	Lift Coupling	1
17	E20242	Pan Hd Phil Machine Screw M3x20 Zinc	2	37	E84344	Squeegee Support Wheel	2
18	E82317	Hex Jam Nut, M5X3.5 Zinc	2	38	E84345	Pivot Plate	1
19	E20113	Hex Jam Nut, M6X4 SS	1	39	E84346	Spacer	1
20	E83672	Hex Jam Nut, M8x5 SS	2	40	E84347	Spacer	1

MAIN FRAME DIAGRAM

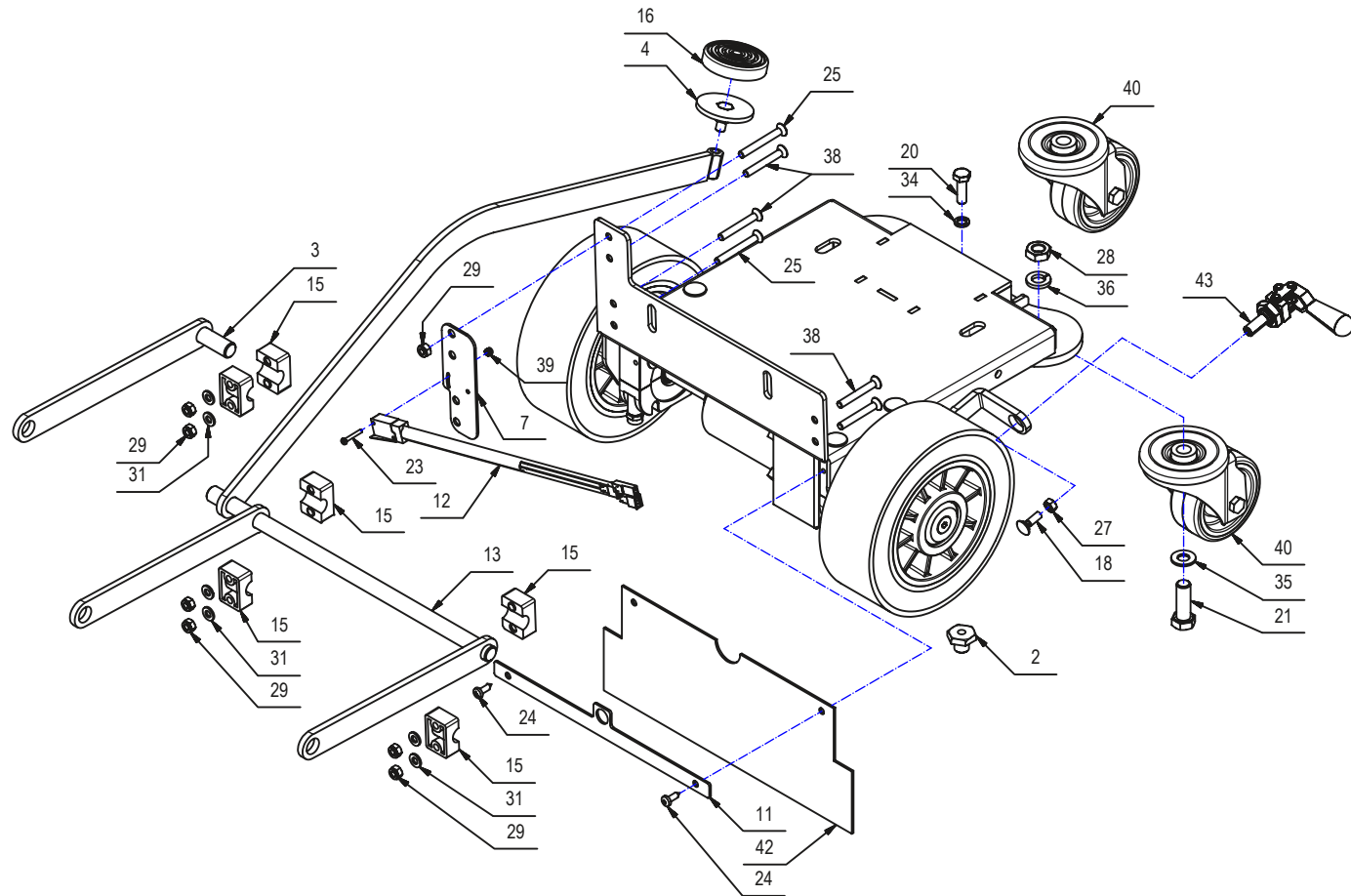

MAIN FRAME PARTS LISTING

Item#	Part #	Description	Qty.	Item#	Part #	Description	Qty.
1	E88253	Bushing	4	24	E20108	Screw, Pan Hd Phil Self Tap M4.8x16 SS	2
2	E20006	Bushing	1	25	E20246	Flat Hd Soc Machine Screw M6x50 Zinc	2
3	E83597	Brush Deck Lift Idler Arm Weldment	1	26	E22002	Screw, M8 x 30	2
4	E20370	Foot Pedal	1	27	E83852	Nut, Hex, M8, Zinc	1
5	E20609	Bearing Mount Base	2	28	E83829	Hex Jam Nut, M12X7 Zinc	2
6	E20014	Bearing Mount Cap	2	29	E83550	NyLoc Hex Nut, M6 Zinc	10
7	E20473	Switch Plate	1	30	E86853	Nyloc Hex Nut, M8 Zinc	4
8	E20315	Shim Plate	2	31	E82761	Flat Washer M6x12x1.6 Zinc	10
9	E20446	Axle Shaft, Right	1	32	E88585	Washer, Flat, M6 x 18, Zinc	2
10	E20458	Axle Shaft, Left	1	33	E88594	Washer, Split Lock, M6, Zinc	2
11	E20071	Clamp Plate	1	34	E81046	Lock Washer M8 Zinc	1
12	E88256	Micro Switch	1	35	E82773	Flat Washer M10x21x2 Zinc	2
13	E20388	Brush Deck Lift Arm Weldment	1	36	E81738	Flat Washer M4x12x3 Zinc	2
14	E20582	Drive Motor 24VDC 150W	1	37	E84333	Bearing Washer	2
14.1.1	E20523	Carbon Brush	2	38	E20255	Flat Hd Soc Machine Screw M6x45 Zinc	4
15	E82834	Pivot Block	6	39	E20435	Nyloc Hex Nut, M3 SS	2
16	E83669	Pedal cover	1	40	E20437	Castor	2
17	E81657	Bearing, 6204 2RS	2	41	E20591	Carriage Bolt M8x100 Zinc	4
18	E20356	Carriage Bolt M6x20 Zinc	1	42	E20501	Splash Guard	1
19	E88888	Hex Bolt, M6 x 40, Zinc	4	43	E20369	Parking Brake	1
20	E83833	Hex Bolt M8x25 Zinc	1	44	E84334	Wheel	2
21	E81735	Hex Bolt M12x35 Zinc	2	45	E84335	Spacer	2
22	E83578	Soc Hd Cap Screw M6x25 Zinc	2	46	E84331	Chassis	1
23	E20242	Pan Hd Phil Machine Screw M3x20 Zinc	2				

TRANSAXLE DIAGRAM

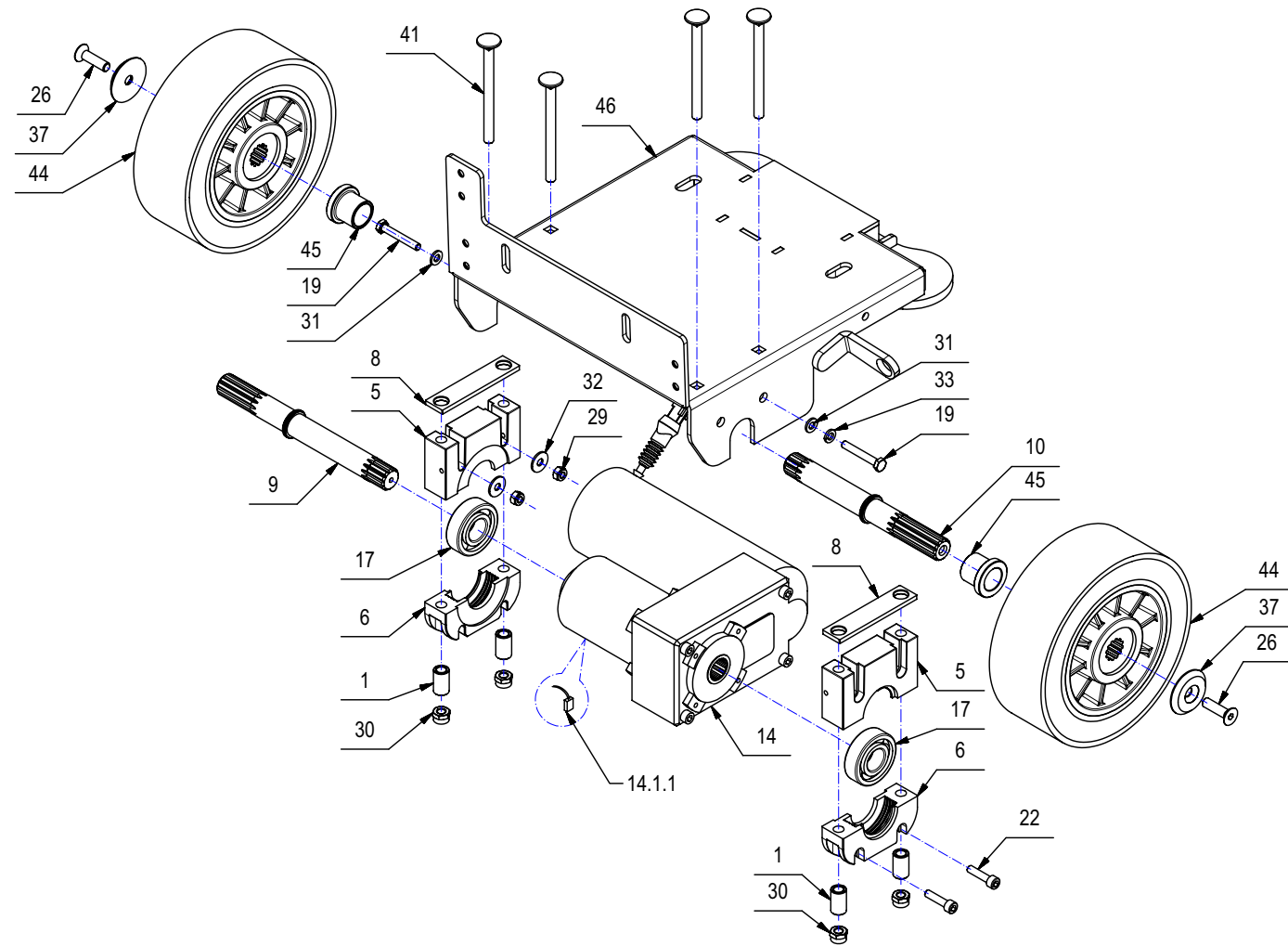

TRANSAXLE PARTS LISTING

Item#	Part #	Description	Qty.	Item#	Part #	Description	Qty.
1	E88253	Bushing	4	24	E20108	Screw, Pan Hd Phil Self Tap M4.8x16 SS	2
2	E20006	Bushing	1	25	E20246	Flat Hd Soc Machine Screw M6x50 Zinc	2
3	E83597	Brush Deck Lift Idler Arm Weldment	1	26	E22002	Screw, M8 x 30	2
4	E20370	Foot Pedal	1	27	E83852	Nut, Hex, M8, Zinc	1
5	E20609	Bearing Mount Base	2	28	E83829	Hex Jam Nut, M12X7 Zinc	2
6	E20014	Bearing Mount Cap	2	29	E83550	NyLoc Hex Nut, M6 Zinc	10
7	E20473	Switch Plate	1	30	E86853	Nyloc Hex Nut, M8 Zinc	4
8	E20315	Shim Plate	2	31	E82761	Flat Washer M6x12x1.6 Zinc	10
9	E20446	Axle Shaft, Right	1	32	E88585	Washer, Flat, M6 x 18, Zinc	2
10	E20458	Axle Shaft, Left	1	33	E88594	Washer, Split Lock, M6, Zinc	2
11	E20071	Clamp Plate	1	34	E81046	Lock Washer M8 Zinc	1
12	E88256	Micro Switch	1	35	E82773	Flat Washer M10x21x2 Zinc	2
13	E20388	Brush Deck Lift Arm Weldment	1	36	E81738	Flat Washer M4x12x3 Zinc	2
14	E20582	Drive Motor 24VDC 150W	1	37	E84333	Bearing Washer	2
14.1.1	E20523	Carbon Brush	2	38	E20255	Flat Hd Soc Machine Screw M6x45 Zinc	4
15	E82834	Pivot Block	6	39	E20435	Nyloc Hex Nut, M3 SS	2
16	E83669	Pedal cover	1	40	E20437	Castor	2
17	E81657	Bearing, 6204 2RS	2	41	E20591	Carriage Bolt M8x100 Zinc	4
18	E20356	Carriage Bolt M6x20 Zinc	1	42	E20501	Splash Guard	1
19	E88888	Hex Bolt, M6 x 40, Zinc	4	43	E20369	Parking Brake	1
20	E83833	Hex Bolt M8x25 Zinc	1	44	E84334	Wheel	2
21	E81735	Hex Bolt M12x35 Zinc	2	45	E84335	Spacer	2
22	E83578	Soc Hd Cap Screw M6x25 Zinc	2	46	E84331	Chassis	1
23	E20242	Pan Hd Phil Machine Screw M3x20 Zinc	2				

SOLUTION TANK DIAGRAM

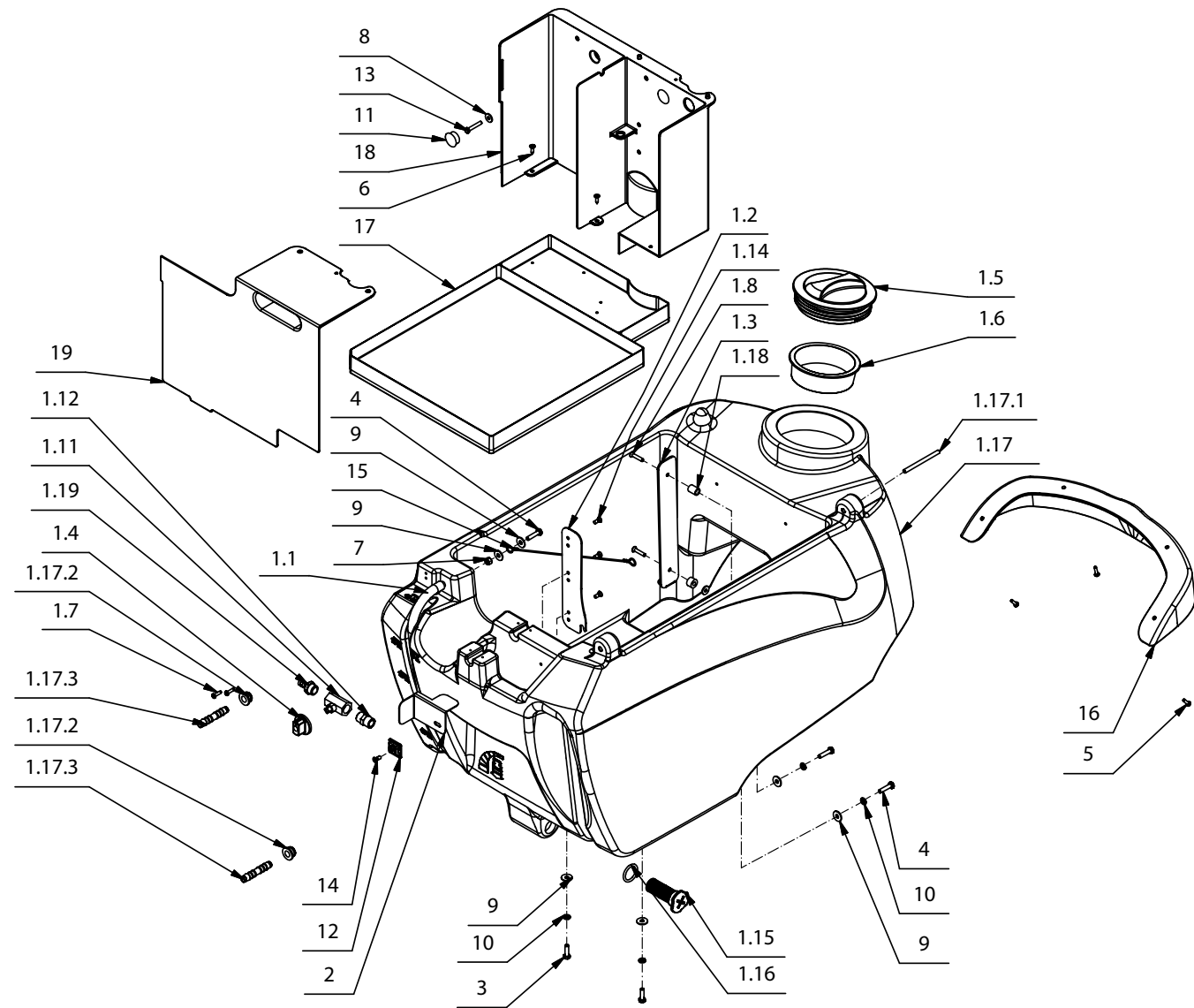

SOLUTION TANK PARTS LISTING

Item#	Part #	Description	Qty.	Item#	Part #	Description	Qty.
1	E20285	Solution Tank ASM	1	1.18	E20577	Spacer	1
1.1	E88258	Hose, Glass Reinforced 15 OD x 10 ID x 496 L	1	1.19	E20602	Fitting, Barbed Threaded	1
1.2	E20409	Foot Pedal Latch Plate	1	2	E20411	Bracket	1
1.3	E20611	Guard Plate	1	3	E82772	Hex Bolt M6x20 Zinc	2
1.4	E86145	Knob	1	4	E20090	Hex Bolt M6x25 Zinc	3
1.5	E82429	Cap	1	5	E20392	Pan Hd Phil Machine Screw M4x16 Zinc	4
1.6	E82612	Filter	1	6	E83796	Screw, Pan Hd Phil Self Tap M4.2x16 Zinc	5
1.7	E20107	Screw, Pan Hd Phil Self Tap M4.2x16 SS	2	7	E20112	Hex Nut, M6x6 Zinc	1
1.8	E20110	Flat Hd Soc Machine Screw M5x25 SS	2	8	E20121	Flat Washer M5x15x1.5 Zinc	2
1.9	E20122	Flat Washer M5 x 15 x 1.5 SS	1	9	E82798	Washer, 6x18x1.5	6
1.10	E85762	Hose Clamp	1	10	E82774	Lock Washer, M6 Zinc	4
1.11	E83361	Ball Valve	1	11	E20708	Cover, Bolt	2
1.12	E83943	Nipple, Double Female 3/8"	1	12	E81619	Support Bracket	1
1.13	E81981	Spacer	1	13	E20359	Hex Bolt M5x30 Zinc	2
1.14	E20468	Flat Hd Phil Machine Screw M5x12 Zinc	3	14	E20468	Flat Hd Phil Machine Screw M5x12 Zinc	1
1.15	E88259	Filter, Water 23 x 53 Plug 3/4"	1	15	E88260	Lanyard	1
1.16	E88261	Flat Washer M8.2x32x4 Zinc	1	16	E20438	Bezel	1
1.17	E20197	Solution Tank, Gray	1	17	E20709	Battery Tray	1
1.17.1	E20389	Hinge Pin	1	18	E20710	Housing, Plastic	1
1.17.2	E20271	Grommet	2	19	E20711	Housing Cover, Plastic	1
1.17.3	E20196	Fitting, Barbed	2				

RECOVERY TANK DIAGRAM

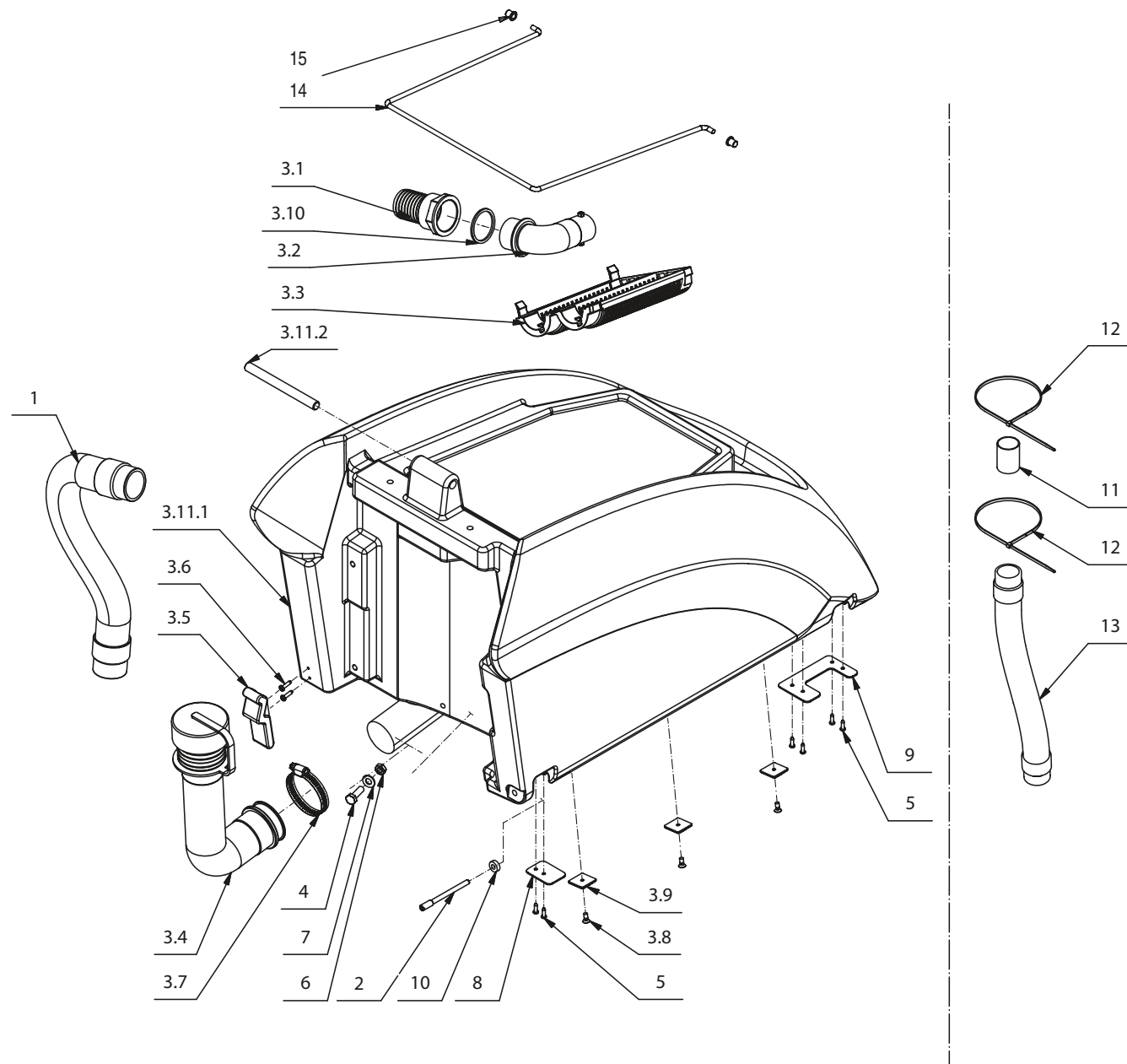

RECOVERY TANK PARTS LISTING

Item#	Part #	Description	Qty.	Item#	Part #	Description	Qty.
1	E88499	Hose, Vacuum	1	3.11.2	E20188	Hinge Pin	1
2	E20074	Hinge Pin	1	4	E83833	Hex Bolt M8x25 Zinc	1
3	E20354	Recovery Tank ASM	1	5	E82638	Screw, Pan Hd Phil Self Tap M3.9x13 SS	6
3.1	E20189	Fitting, Barbed	1	6	E82808	Hex Jam Nut, M8X5 Zinc	1
3.2	E20186	Elbow	1	7	E20127	Flat Washer M9x18x1.5 Zinc	1
3.3	E88285	Filter, Cage	1	8	E20563	Plate	1
3.4	E88286	Hose, Drain	1	9	E20195	Plate	1
3.5	E12633	Latch	1	10	E20524	Spacer, Nylon	1
3.6	E20107	Screw, Pan Hd Phil Self Tap M4.2x16 SS	2	11	E88500	Fitting, Hose D38, W1.5, L50	1
3.7	E20707	Clamp, Hose M40-64 Zinc	1	12	E83920	Clamp 9x300 4,8x360 black	2
3.8	E20468	Flat Hd Phil Machine Screw M5x12 Zinc	3	13	E88499	Hose, Vacuum	1
3.9	E81619	Cable Tie Holder	3	14	E22072	Bale, Vac Lid	1
3.10	E82341	Gasket	1	15	E22074	Plug, Vac Lid Bale	2
3.11.1	E20198	Recovery Tank, Red	1				

VACUUM UNIT DIAGRAM

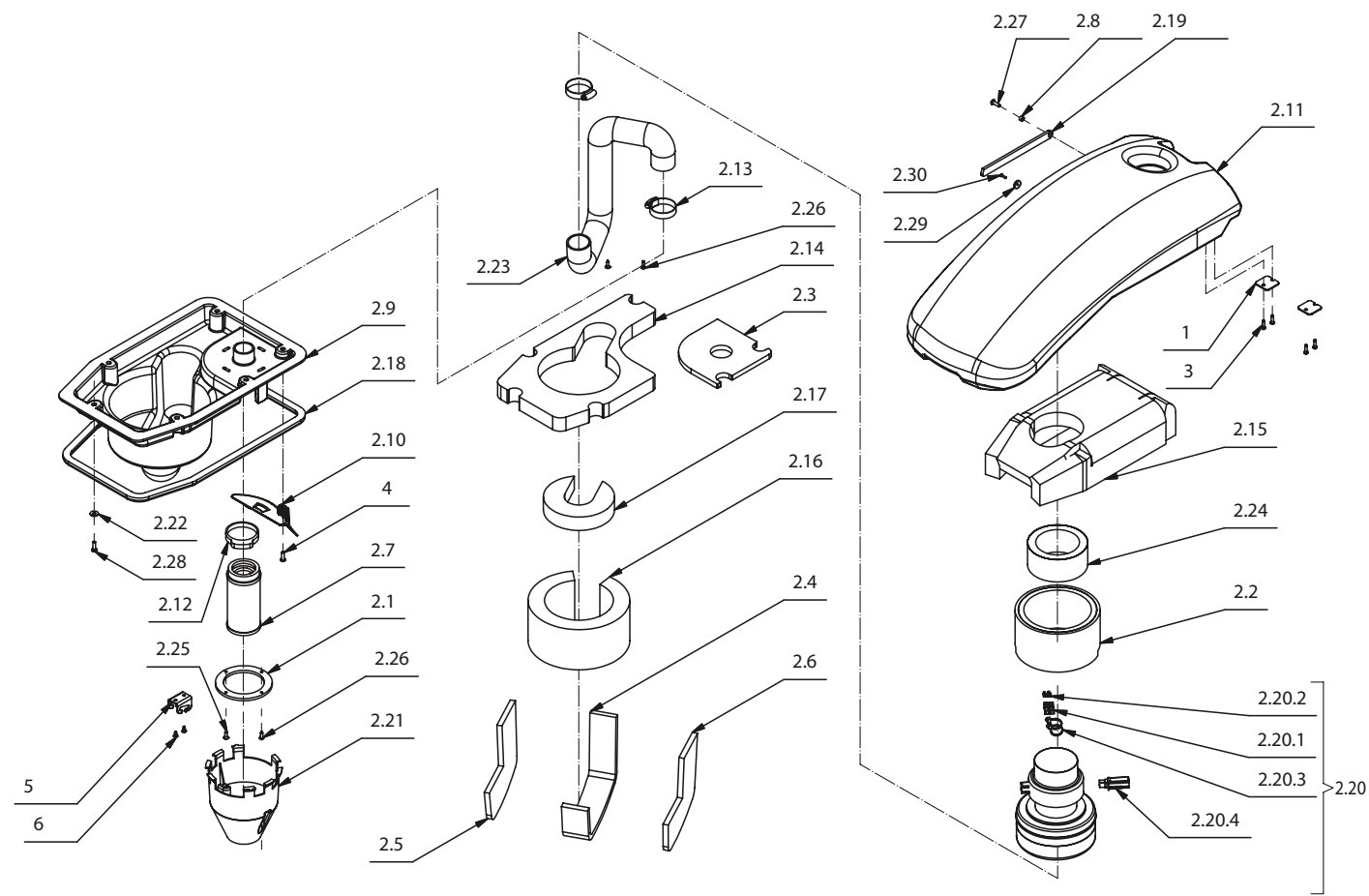

VACUUM UNIT PARTS LISTING

Item#	Part #	Description	Qty.	Item#	Part #	Description	Qty.
1	E20265	Plate	2	2.19	E20064	Support Bracket	1
2	E20066	Recovery Tank Cover ASM	1	2.20	E88291	Vacuum Motor 24VDC 310W	1
2.1	E20305	Mounting Ring	1	2.20.1	E83897	Connector, Electrical Housing 30A	2
2.2	E20652	Sound Deadening Foam	1	2.20.2	E83883	Lug, Electrical 30A	2
2.3	E20180	Sound Deadening Foam	1	2.20.3	E83935	Wire Tie	2
2.4	E20179	Sound Deadening Foam	1	2.20.4	E22324	Carbon Brush	2
2.5	E20178	Sound Deadening Foam	1	2.21	E81006	Vacuum Splash Guard	1
2.6	E20266	Sound Deadening Foam	1	2.22	E20122	Flat Washer M5 x 15 x 1.5 SS	5
2.7	E88292	Filter, Cage	1	2.23	E88290	Hose, Vacuum	1
2.8	E20486	Bushing	1	2.24	E20440	Sound Deadening Foam	1
2.9	E20384	Vacuum Motor Cover	1	2.25	E83796	Screw, Pan Hd Phil Self Tap M4.2x16 Zinc	2
2.10	E20191	Deflector	1	2.26	E83838	Screw, Flat Hd M4x15 Zinc	2
2.11	E20199	Recovery Tank Cover	1	2.27	E20442	Button Hd Soc Machine Screw M5x16 Zinc	1
2.12	E81710	Hose Clamp	1	2.28	E20084	Hex Bolt M5x16 SS	5
2.13	E20325	Hose Clamp	2	2.29	E20712	Magnet	1
2.14	E20181	Sound Deadening Foam	1	2.30	E20192	CHIPBOARD SCREW M3x12 Zinc	1
2.15	E20184	Sound Deadening Foam	1	3	E20107	Screw, Pan Hd Phil Self Tap M4.2x16 SS	4
2.16	E20183	Sound Deadening Foam	1	4	E20298	Soc Button Head Screw M5x16 SS	1
2.17	E20182	Sound Deadening Foam	1	5	E22075	Hook, Vac Lid Bale	1
2.18	E88289	Gasket	1	6	E22076	Screw, M4 x 10	2

SOLUTION DELIVERY DIAGRAM

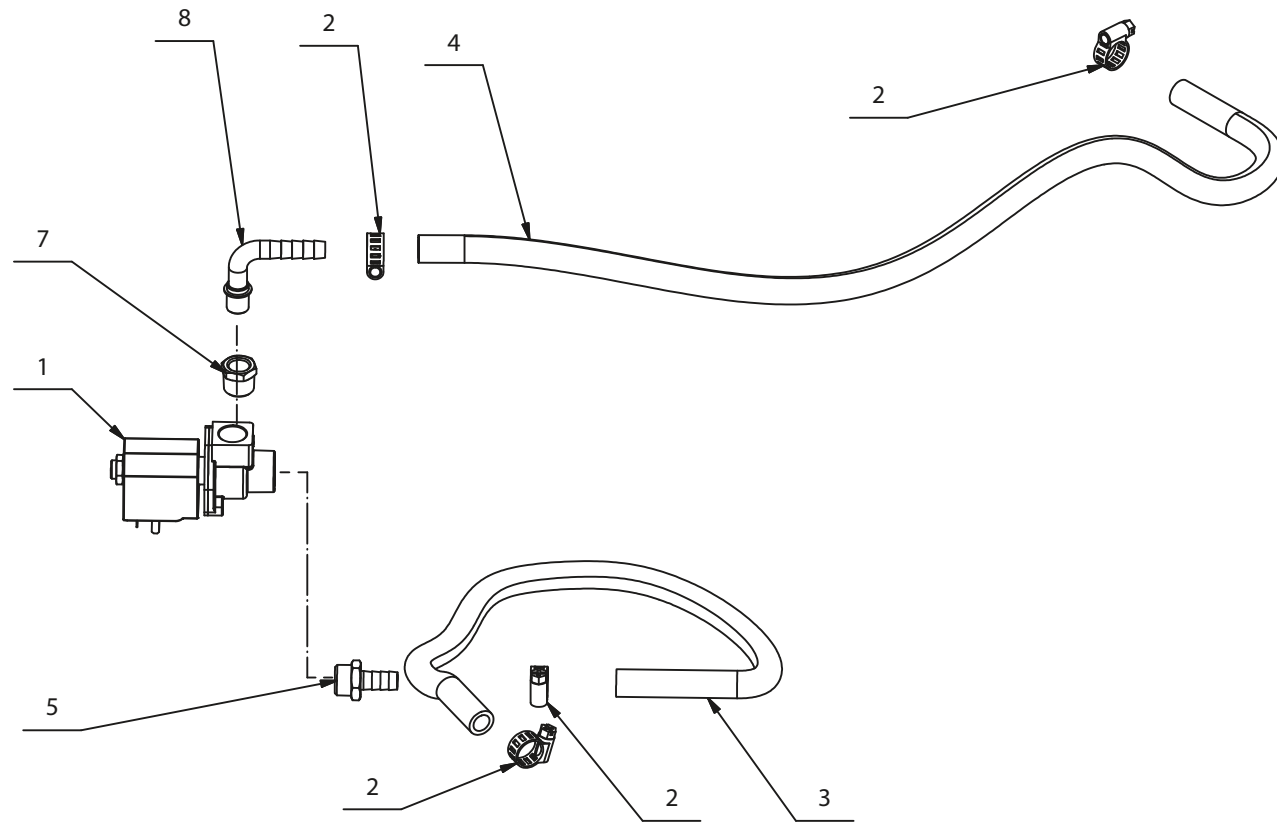

SOLUTION DELIVERY PARTS LISTING

Item#	Part #	Description	Qty.
1	E81035	Solenoid Valve	1
2	E85762	Hose Clamp	4
3	E22144	Tubing, 10 ID x 370 L	1
4	E20375	Tubing, 10 ID x 650 L	1

Item#	Part #	Description	Qty.
5	E20602	Fitting, Threaded Barb	1
7	E22145	Fitting, 3/8" - 1/4" Reducer	1
8	E88829	Fitting, 90 Degree Elbow	1

HANDLEBAR DIAGRAM

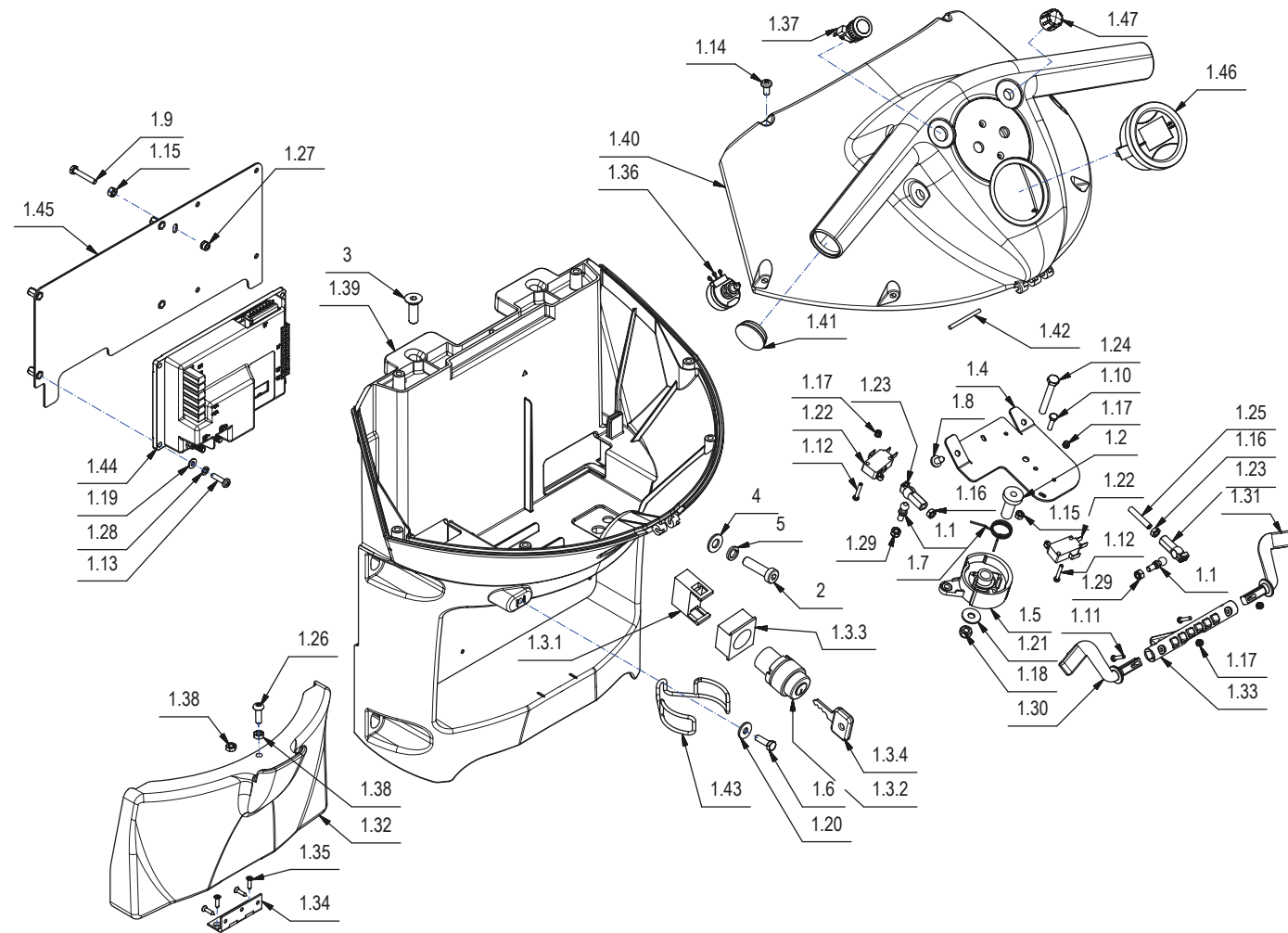

HANDLEBAR PARTS LISTING

Item#	Part #	Description	Qty.	Item#	Part #	Description	Qty.
1.1	E20330	Ball Stud M10x22.5	2	1.25	E20362	Set Screw Hex Soc Dog Point M5x30 Zinc	1
1.2	E20574	Bushing	1	1.26	E20298	Soc Button Head Screw M5x16 SS	1
1.3	E82351	Key Switch Assembly w/Keys	1	1.27	E81978	Nut	1
1.3.1	E83173	Contact, Key Switch	1	1.28	E20475	Lock Washer M4 Zinc	4
1.3.2	E83316	Key Switch	1	1.29	E82256	Nyloc Hex Nut, M5x7 Zinc	2
1.3.3	E81358	Switch Flange	1	1.3	E88300	Lever, Left Switch	1
1.3.4	E83315	Switch Key (1)	1	1.31	E88301	Lever, Right Switch	1
1.4	E22079	Plate, Electrical Panel	1	1.32	E20267	Door	1
1.5	E81763	Cam	1	1.33	E88267	Switch Cam	1
1.6	E83836	Hex Bolt M5x16 Zinc	1	1.34	E20400	Hinge	1
1.7	E82304	Spring, 20.2x1.3x20.8mm Steel Torsion	1	1.35	E20192	Screw, Chipboard, M3x12 Zinc	4
1.8	E83851	Screw, Pan Hd Phil Self Tap, M5.5x13, SS	2	1.36	E20713	Potentiometer	1
1.9	E84348	Screw, M4 x 25 Zinc	1	1.37	E84350	Push Button	1
1.1	E20341	Hex Bolt M4x16 Zinc	1	1.38	E22619	Nut	2
1.11	E84349	Bolt, M3 x 16	2	1.39	E22082	Lower Handle Bar	1
1.12	E20242	Pan Hd Phil Machine Screw M3x20 Zinc	4	1.4	E22083	Upper Handle Bar	1
1.13	E20392	Pan Hd Phil Machine Screw M4x16 Zinc	4	1.41	E22084	Cap, Handle Bar	2
1.14	E83899	Screw, Machine, Pan Hd Phil, M5x10, SS	6	1.42	E22085	Hinge Pin	1
1.15	E20248	Hex Nut, M4x4 Zinc	2	1.43	E22620	Hose Clip	1
1.16	E82317	Hex Jam Nut, M5X3.5 Zinc	2	1.44	E84351	Control Card	1
1.17	E81673	Nut, Hex Nyloc, M3 Zinc	6	1.45	E84352	Plate	1
1.18	E83550	NyLoc Hex Nut, M6 Zinc	1	1.46	E84353	Battery Discharge Indicator	1
1.19	E20292	Flat Washer M4x9x0.8 Zinc	4	1.47	E84354	Speed Control Knob	1
1.2	E20121	Flat Washer M5x15x1.5 Zinc	1	2	E20288	Soc Hd Cap Screw M8x30 Zinc	4
1.21	E88585	Washer, Flat, M6 x 18, Zinc	1	3	E20346	Screw, Flat Hd Soc Machine, M8x25, SS	2
1.22	E82270	Micro Switch	2	4	E81874	Flat Washer M8x17x1.6 Zinc	4
1.23	E81625	Shank, M5x32 Female Threaded Nylon	2	5	E81046	Washer, Lock, M8, Zinc	4
1.24	E20360	Hex Bolt M6x45 Zinc	1	6	E89890	Battery Cable w/ 80Amp Fuse	1

ELECTRICAL DIAGRAM

ELECTRICAL PARTS LISTING

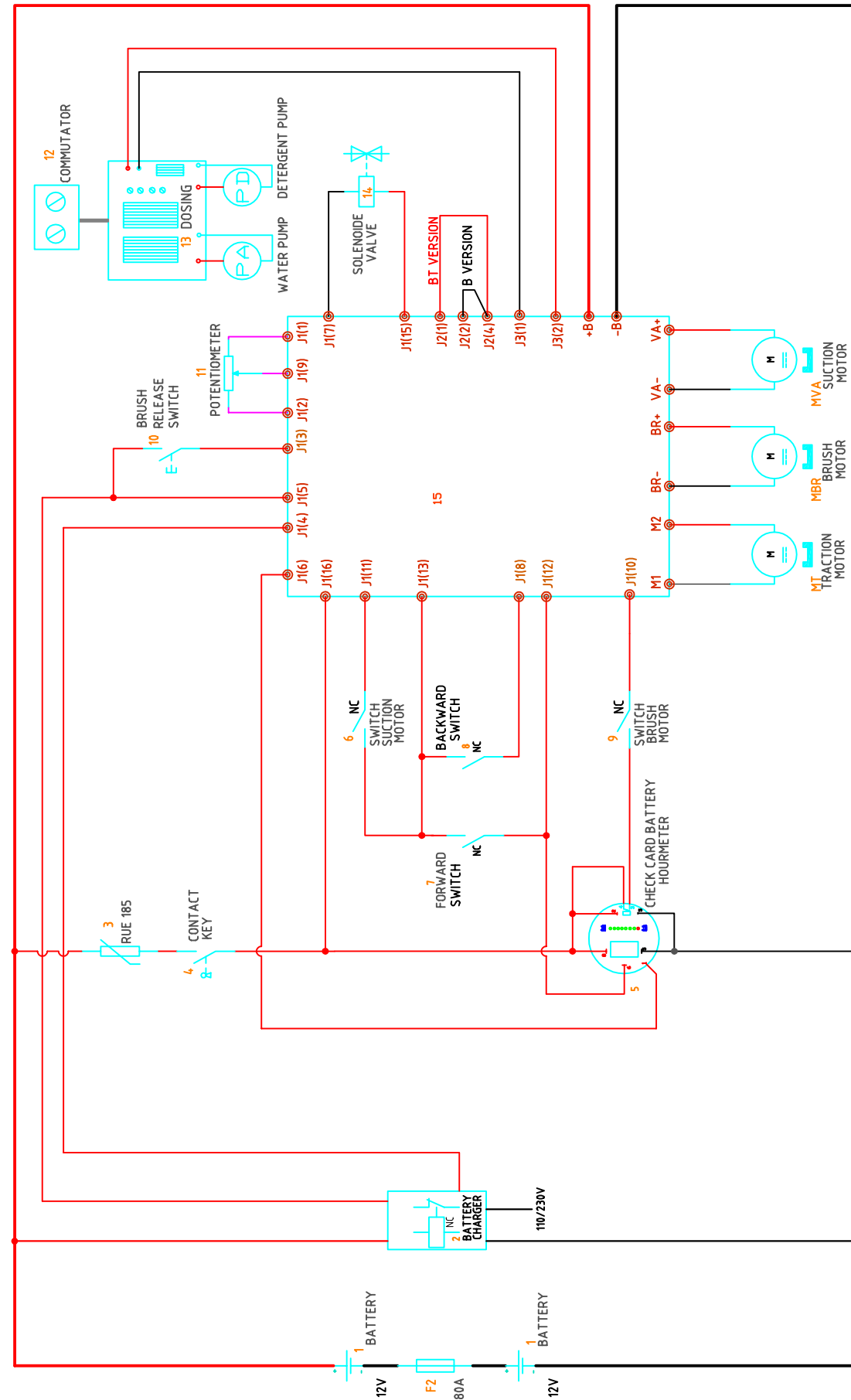

COLOR LEGEND
 1, 2, ... =COMPONENTS
 JX(Y), ... =PCB CONNECTIONS

Item#	Part #	Description	Qty.
1	Various	Batteries	2
2	Various	Battery Charger	1
3		Fuse	1
4	E83316	Key Switch	1
5	E84353	Battery Discharge Indicator	1
6	E88279	Microswitch Vacuum Motor	1
7	E82270	Microswitch Forward	1
8	E82270	Microswitch Reverse	1
9	E88256	Microswitch Brush Motor	1
10	E84350	Push Button	1

Item#	Part #	Description	Qty.
11	E20713	Potentiometer	1
12	N/A	Dilution Control Commutator Card (Not Used)	0
13	N/A	Dilution Control Card (Not Used)	0
14	E81035	Solenoid Valve	1
15	E84351	Control Card	1
F2	E89890	Fuse 80A	1
MT	E20582	Traction Motor	1
MBR	E84328	Brush Motor	1
MVA	E88291	Vacuum Motor 24VDC 310W	1

BATTERY CHECK CARD / HOUR METER

1. Verify that when turning on the machine, the battery discharge indicator has the following starting sequence:

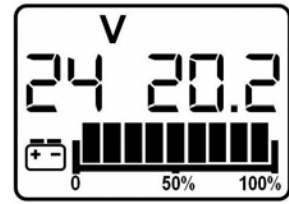

- For the first 2 seconds, display the setting of the dip switches.

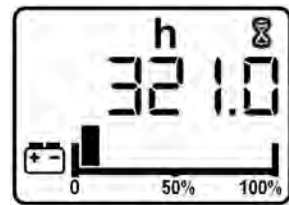

- Then display the total worked hours and level of residual charge of the battery.

During the first 2 seconds, the value displayed on the left indicates the rated voltage set for the battery discharge indicator. The value on the right indicates the low voltage shutoff threshold.

For Wet Cell batteries, the low voltage shutoff should be equal to 20.2V.
For Gel or AGM batteries, the low voltage shutoff should be equal to 21.8V.

2. The battery discharge indicator should be adjusted according to the type of batteries that are installed in the machine. To change the settings, simply adjust the dip switches located on the back of the device.
The grid below shows the proper settings for each battery type.



Hour meter Dip Switch Settings

1	2	3	4	5	6	Setup
OFF	ON	OFF	OFF	OFF	OFF	Wet Cell
OFF	ON	ON	OFF	OFF	OFF	GEL / AGM

SOLUTION TANK INSPECTIONS

1. Fill up the solution tank and verify the sealing of the gasket particularly on the **solution valve** and on the **drain plug**.
2. Verify that the water distribution on the floor is even and dependent on the solution valve adjustment.
3. Check the internal cleanness of the water valve. If necessary clean it using a metal bar putted inside the threaded hole of the filter plug.

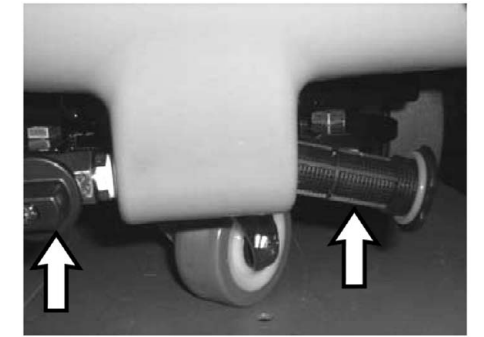

4. Verify the cleanness and functionality of the **solution filter** under the solution tank plug.



VACUUM SYSTEM INSPECTIONS

1. Verify the cleanness and functionality of the **float filter**.
2. Check the air sealing of the **vacuum unit** on the recovery tank.
3. Verify the connections and the sealing of the vacuum hoses and the squeegee hoses.

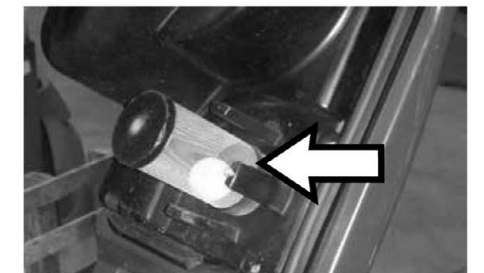

4. Check the sealing of the **squeegee hose adapter**.
5. Check the sealing of the exhaust hose and exhaust hose plug.

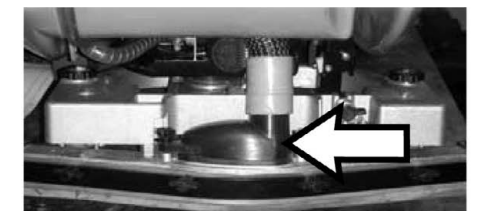

6. Vacuum micro switch adjustment:
7. Adjust the vacuum micro switch in way that when the cam on the squeegee lever **push the micro switch** there is about 0.5 mm of clearance of the micro switch lever.



BRAKE ADJUSTMENT

1. Verify that the brake on the left hand wheel locks the wheel when active.
2. Otherwise adjust as follows:
 - Unscrew the **jam nut**.
 - Loosen the **pad screw** to achieve the right adjustment.
 - Verify the adjustment with a functional test
 - Tighten the **jam nut** to assure a right adjustment.

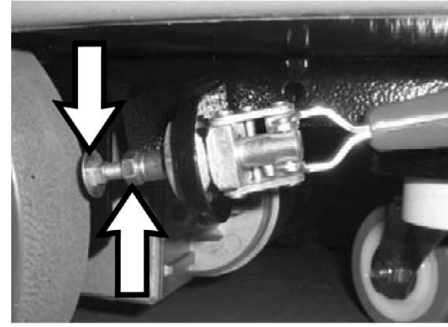

SQUEEGEE ADJUSTMENT

1. Adjust the inclination adjuster of the squeegee blade until the blade has a common inclination over its entire length.
2. Adjust the height of the wheels using the knob checking that the blade has an inclination between 30 and 45 degrees.

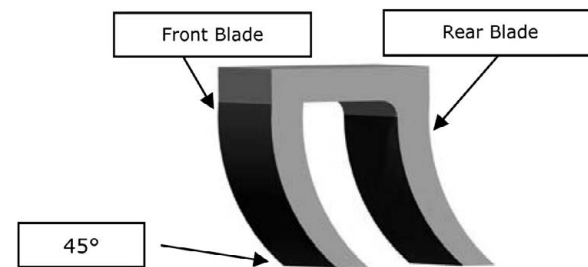

3. Verify the cleanliness and sealing of the squeegee hose adapter.

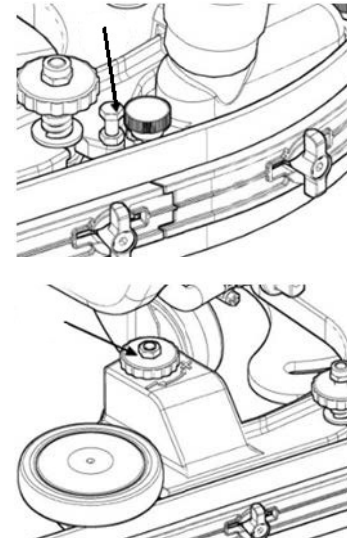

CHECK LIST

Functional check of the machine

- Check the functionality of switches.
- Check the functionality of the switch lever.
- Check the functionality of the orbital deck.
- Check the functionality of the deck motor.
- Check the functionality of the solenoid valve.
- Check the functionality of the vacuum motor.
- Check the functionality of the brakes.
- Check the functionality of batteries and power cables.

Functional test of the machine

- Fill up the tanks completely and verify the sealing.
- Verify the sealing of all the water fittings and that the water is dispensed to the deck.
- Adjust the inclination and the height of the squeegee blades doing a functional test.
- Check the efficiency of the parking brake.
- Verify the forward and backward movement, acceleration and braking.

Final test

- Check all the functions: washing, drying and movement.

BETCO US WARRANTY POLICY

10 year coverage

Subject to the conditions stated below, Betco warrants parts and labor on rotationally molded polyethylene tanks/ housings and injection molded vacuum head assemblies to be free from defects in materials and workmanship for a period of ten years to the original purchaser.

3 Year Coverage

Subject to the conditions stated below, Betco warrants parts and labor on all other Betco components to be free from defects in materials and workmanship for a period of three years to the original purchaser.

- Lithium Ion battery for MotoMop™ is a full 3 years

1 Year Coverage

Subject to the conditions stated below, Betco offers a limited warranty on parts and labor on the following equipment: parts and accessories to be free from defects in materials and workmanship for a period of one year to the original purchaser.

- PowerUp™ 14 Upright Vacuum: #E29990-00
- Bac Pac Lite Vacuum: #85903-00
- FiberPRO® Floor Dryer: #85507-00
- WORKMAN™ Series Vacuums: #85024-00, #85025-00, #83012-00, #85027-00
- All Tools and Accessories
- All Battery Chargers
- Deep cycle batteries are pro-rated for 1 year

Allowable Travel Time Warranty Reimbursement:

Eligible equipment: All battery and propane powered equipment products. Warranty period: 90 days from date of sale to the original purchaser. A maximum 180 mile round trip at 50 cents per mile will be allowed for warranty consideration.

Propane Machine Warranty:

Kawasaki engines are warranted by Kawasaki for a period of 2 years against manufacturer defects. All other components (except wear items)* are warranted by Betco for a period of 3 years.

***Wear Items exempt from Warranty consideration include but may not be limited to: power cords, transport wheels, vacuum bags, belts, squeegee blades, pad drivers, clutch plates, handle grips, filters, screens, throttle cables, brushes and carbon brushes.**

Subject to the conditions and exceptions stated in this warranty, Betco warrants the Betco products to be free from defects in material and workmanship, under normal use and service, for the periods listed under the warranty policy to the original purchaser. At any time during the warranty period, Betco will furnish replacement parts for the Betco parts to the original purchaser. Such parts will be furnished and charged including transportation costs, to the original owner through any Betco authorized Service Distributor. If the original part is returned within the warranty policy period from date of delivery for inspection by Betco and is found to be defective the owner will be credited for the cost of replacement parts plus shipping and handling. Replacement parts that have become defective through wear or abuse are not included in this warranty.

This warranty does not apply to damage or defect caused by accident, misuse, Negligence, fire, or to any Betco product which has been serviced or repaired by other than an authorized Betco Service Distributor or Betco factory personnel. This warranty is void if products are used for any purpose other than that which was intended. There are no other warranties expressed or implied. In no event shall Betco be liable for incidental or consequential damages or any damage to person or property. (Please note some states do not allow the exclusion or limitations for incidental and consequential damages).

