



Electronic Service Manuals

This electronic document is provided as a service to our customers. We do not create the contents of the information contained in this document. Should you have detailed questions pertaining to the information contained in this document, you may contact Michco, or the manufacturer which provided the original information in this electronic deliverable. Michco's only part in this electronic deliverable was the electronic assembly process. By providing this manual on line we are not guaranteeing parts availability.

You may contact Michco through the following methods:

Phone (517) 484-9312 or (800) 331-3339

2011 N. High St. -- Lansing, Michigan -- 48906

Fax: (517) 484-9836

Email: CustServe@Michco.com

Web site: www.Michco.Com

Parts Web site: www.FloorMachineParts.Com

Order Parts on Line at:

www.FloorMachineParts.Com

Directly to Parts & Service:

By Email: **Shop@Michco.com**

By Fax: (517) 702-2041

By Voice: Use numbers above.

Serving the Cleaning Industry Since 1922

Notice: All copyrighted material remains property of original owners, all trademarks are property of respective owners. Manuals are subject to Manufacturer's reproduction limitations. Originals or reproductions were provided by manufacturers through a request. We make no warranty as to the correctness of information provided in this document and you assume all risk. By placing these manuals on line we are not declaring our corporation to be an manufacturer authorized dealer or provider, please check our web site for authorized manufacturers we represent.



E87028-00
E88063-00



STEALTH™ ASD20BT

20" Automatic Scrubber
with Traction Drive



Scan this QR code to view
operator training video

**Operator and Parts
Manual**

TABLE OF CONTENTS

RECEIVING THE MACHINE.....	3 - 4
GENERAL SAFETY REGULATIONS.....	5
MACHINE PREPARATION.....	6 - 12
OPERATION	13 - 14
TURNING OFF THE MACHINE	15
DAILY MAINTENANCE.....	16 -17
WEEKLY MAINTENANCE.....	18
TROUBLESHOOTING	19
BRUSH AND SELECTION USE.....	19
PARTS DIAGRAMS AND LISTINGS.....	20 - 39
ELECTRICAL SYSTEM.....	40 - 42
BATTERY CHECK CARD – HOUR METER.....	43
HYDRAULIC PLANT INSPECTIONS.....	43
VACUUM SYSTEM INSPECTION	44
BRUSH BASE ADJUSTMENT	45
BRAKE ADJUSTMENT.....	45
SQUEEGEE ADJUSTMENT	46
CHECK LIST	46
MAINTENANCE SCHEDULE AND WEAR ITEMS	47
WARRANTY	48

RECEIVING THE MACHINE

Immediately check, when receiving the machine, that all the materials indicated on delivery documents have been received and also that the machine has not been damaged in transit. If it has been damaged, this damage must be immediately reported to the shipper and also to our customer's service department. Only acting promptly in this manner will make it possible to receive missing material and to be compensated for damage.

INTRODUCTION

This is an automatic scrubber which, via the mechanical action of the rotating brush and the chemical action of a water/detergent solution, can clean many types of hard flooring. As it advances, it also collects the dirt removed and the detergent solution not absorbed by the floor.

The machine must be used only for this purpose. Even the best machines will only work well if used correctly and kept in good working order. We therefore suggest you read this instruction booklet carefully and re-read it whenever difficulties arise while using the machine. Please contact our technical service department or your dealers if you have any questions about the machine.

Serial # Plate

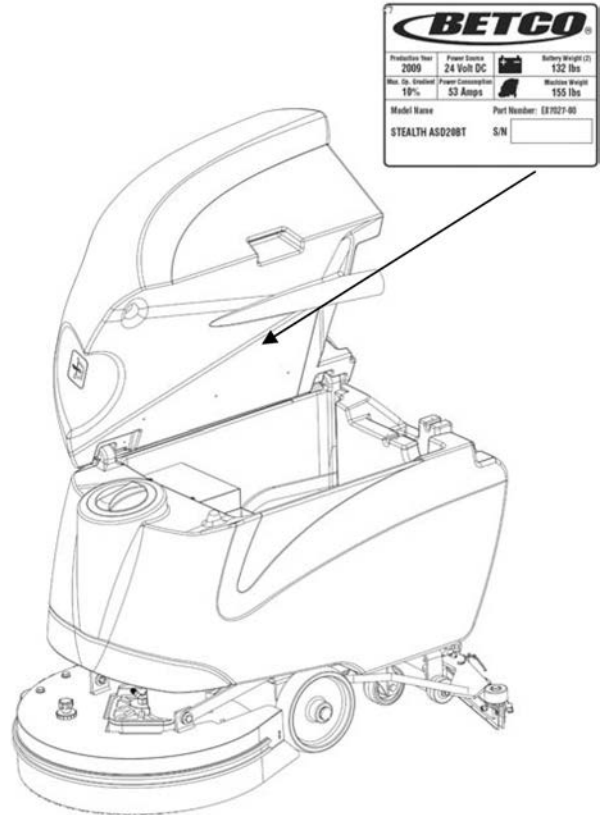

SYMBOLS USED ON THE MACHINE

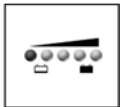

Battery charge gauge



Battery symbol



Open book symbol

Used to tell the operator to read the manual before using the machine



Maximum solution temperature gauge

Located near the solution tank inlet

TECHNICAL DESCRIPTION	Measurement Unit	Stealth™ ASD20BT
Rated power	HP (W)	1.5 (1100)
Working width	In (mm)	19.7 (500)
Rear squeegee width	In (mm)	29.2 (742)
Work capacity	ft ² /h (m ² /h)	22,050 (1450)
Water consumption	g/m ²	38
Brush & Pad (diameter)	in (mm)	20 (500)
Brush RPM	RPM	140
Brush pressure	lb. (Kg)	51 (23)
Brush motor	V / HP (V / W)	24 / 0.54 (24 / 400)
Drive Type		Automatic
Traction motor	V / HP (V / W)	24 / 0.20 (24 / 400)
Forward movement speed	mph (km/h)	2.5 (4)
Maximum grade		10%
Vacuum motor	V / HP (V / W)	36 / 0.74 (36 / 550)
Vacuum motor suction	inches of water (mbar)	75.6 (188)
Solution tank capacity	Gal (l)	11 (40)
Recovery tank capacity	Gal (l)	13 (50)
Weight of machine (excluding batteries)	lb. (Kg)	210 (95)
Batteries	V / Ah	12 / 130 (2)
Charger	V / A	24 / 12
Battery compartment dimensions (Length / Height / Width)	in x in x in (mm/mm/mm)	14.2 x 12.8 x 13.0 (360 / 325 / 330)
Machine dimensions (Length / Height / Width)	in x in x in (mm/mm/mm)	45.3 x 39.4 x 20.9 (1150 / 1000 / 530)
Noise level	dBA	58

GENERAL SAFETY REGULATIONS

The regulations below must be carefully followed in order to avoid harm to the operator and damage to the machine.

- Read all labels on the machine carefully. Do not cover them for any reason and replace them immediately if they become damaged.
- The machine must be used exclusively by authorized and trained personnel.
- When operating the machine be careful of other people.
- The machine is not designed for cleaning carpets.
- The power cable outlet must be provided with a proper ground.
- Avoid damaging the power cable of the battery charger by crushing, bending, cutting or stressing it.
- Whenever the power cable of the battery charger is damaged, immediately contact a BETCO service center.
- Do not mix different types of detergent as this may produce harmful gases.
- Do not set containers on the machine.
- Machine storage temperature is between -10°F and 130°F, never store outside under humid conditions.
- Operating conditions: room temperature between 33°F and 100°F with relative humidity between 30% to 95%.
- Only use the machine in closed areas and do not expose it directly to rain.
- Never use the machine in an explosive environment.
- Do not use the machine as a means of transport.
- Never use acidic chemicals which could damage the machine.
- Avoid running the brushes with the machine stopped; this could damage the floor.
- Never vacuum up flammable liquids.
- Never use the machine to gather dangerous powders.
- Use a powder fire extinguisher in case of fire. Do not use water.
- Do not hit against shelving or scaffolding. The operator must always be equipped with the appropriate safety device (gloves, shoes, helmet, glasses, etc.)
- Do not use the machine on surfaces with an inclination greater than the one shown on the serial plate.
- The machine is designed to wash and dry floors simultaneously. Signal the presence of wet floors with suitable signs.
- If the machine does not work properly, perform routine maintenance. Otherwise, request the assistance of the BETCO technical service.
- When replacing parts ask for ORIGINAL spare parts from your Authorized BETCO Dealer and/or Retailer.
- Always turn off the machine and disconnect the battery connector whenever maintenance is performed.
- Never remove guards that require tools for removal.
- **Never wash the machine with direct or pressurized jets of water or with corrosive substances.**
- Have your BETCO service center check the machine once a year.
- To prevent the formation of scale in the solution tank filter, do not store the machine with detergent solution in the tanks.
- Before using the machine make sure that all doors and covers are positioned as shown in this operating and maintenance manual.
- When your BETCO machine is ready to be retired, the machine must be disposed of properly. It contains oils and electronic components. The machine was built using totally recyclable materials.
- Use only brushes furnished with the machine or those specified in the user's manual. Use of other brushes can compromise safety.
- When removing the battery, unplug the battery connection, unplug the charger and disconnect the battery terminals.
- Before recycling the machine, remove the battery.

MACHINE PREPARATION

1. HANDLING THE PACKED MACHINE

The machine is contained in specific packaging.

It is not possible to place more than two packages on top of each other.

The total weight is 220 lb. (100 kg).

The overall dimensions of the package are:

A : 45.1 in (1145 mm)

B : 26.2 in (665 mm)

C : 48.4 in (1230 mm)

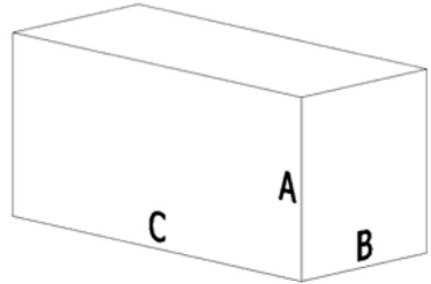

2. HOW TO UNPACK THE MACHINE

A. Remove the outer packaging.

B. The machine is fixed to the pallet with wedges which lock the wheels.

C. Remove these wedges.

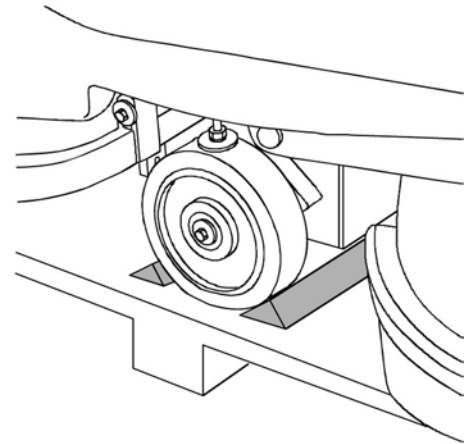

D. Use a ramp to get the machine down from the pallet, pushing it backwards.

E. Keep the pallet for any future transport needs.

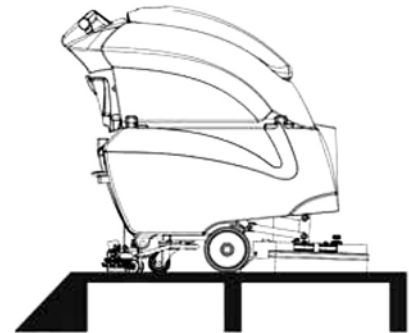

MACHINE PREPARATION

3. BATTERY INSTALLATION

The machine will be supplied with a battery charger and either two 12V Wet or AGM batteries. The batteries must be housed in the battery tray in the battery compartment beneath the recovery tank.

To insert the batteries you must:

- A. Lower the squeegee and brush deck.
- B. Open the rear latch that secures the recovery tank (2).
- C. Rotate the recovery tank as far as it will go, using the side handle (3).



WARNING: To avoid acid leakage you can use sealed batteries.

WARNING: Perform one battery charging cycle before using the machine.



4. TYPE OF BATTERY

To power the machine you can use:

- Wet batteries
- AGM batteries
- Gel batteries

OTHER TYPES MUST NOT BE USED.

The maximum dimensions and the weight are:

- Width 6.7 in (171 mm)
- Length 12.9 in (329 mm)
- Height 9.6 in (245 mm)
- Weight 68 lb. (31 kg)



WARNING: Your charger must be set according to the type of battery you install. Call BETCO customer service to ensure correct charger setting after replacement batteries are installed.

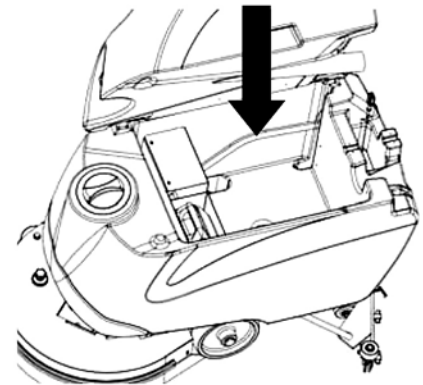

- The batteries must be handled using lifting and transportation means suitable for the weight and dimensions.
- They must be lifted by the handles on the upper part.
- They must be connected together in series, to obtain an overall voltage of 24V on the lugs.
- The electrical connection operations must be carried out by certified trained personnel.

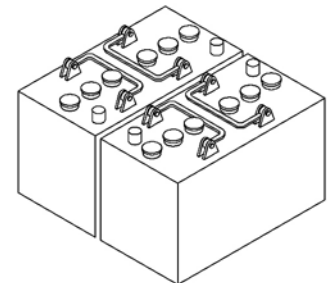

MACHINE PREPARATION

5. BATTERY MAINTENANCE

For maintenance and recharging, follow the instructions provided by the battery manufacturer.

6. BATTERY DISPOSAL

When the battery reaches the end of its working life, it must be disconnected by certified professional, and removed from the battery compartment.

7. CONNECTING THE BATTERY CHARGER

Beneath the recovery tank there is the battery connector (7), the battery charger connector must be plugged into. Disconnect the battery plug and plug the charger into the machine plug.



WARNING: This process must be carried out by qualified personnel. The incorrect or imperfect connection of the cables to the connector can seriously harm people and damage objects.

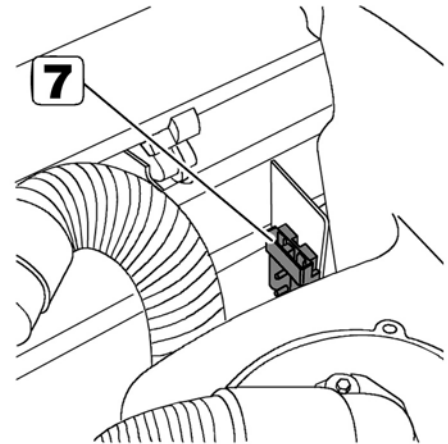

8. RECHARGING THE BATTERIES

Perform one complete battery charge cycle before using the machine. Avoid totally discharging the batteries! This can cause permanent damage to them. Recharge as soon as the battery discharged signal light starts to flash.



WARNING: Never leave the batteries completely discharged, not even if the machine is not being used. This can cause permanent damage to them. While recharging, keep the recovery tank raised. Ensure the battery charger is suitable for the batteries installed.

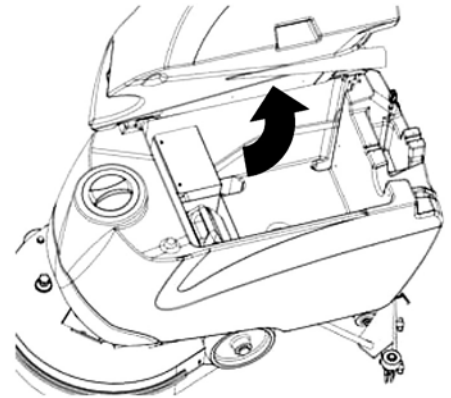

Danger of inhalation of gas and leakage of corrosive liquids.



Danger of fire: do not go near flames.

MACHINE PREPARATION

9. CONNECTING THE BATTERY CONNECTOR

Connect the battery connector (2) to the machine connector (1)

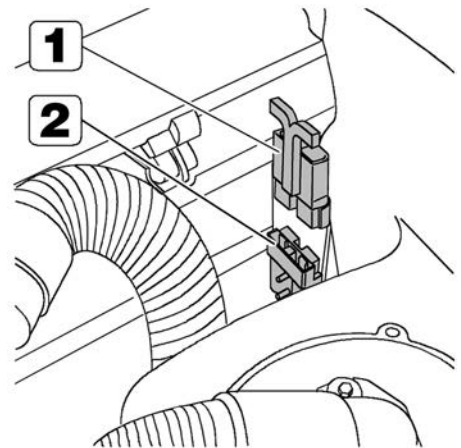

10. BATTERY INDICATOR

The battery indicator uses LEDs and has 8 positions (7 yellow - charged batteries, and 1 red - run down batteries).



WARNING: A few seconds after the red indicator light comes on, the brush motor switches off automatically. With the remaining charge it is possible to complete the drying process before recharging.

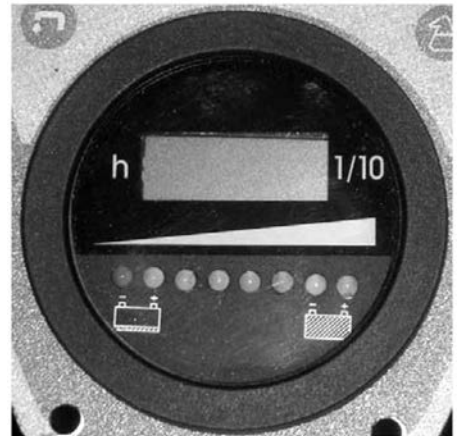

MACHINE PREPARATION

11. INSTRUMENT PANEL COMPONENTS

The instrument panel components are identified as follows:

- A. Levers to activate brushes / traction (located beneath the handlebar)
- B. ON/OFF key switch
- C. Battery level / hour-counter display
- D. Traction speed control knob

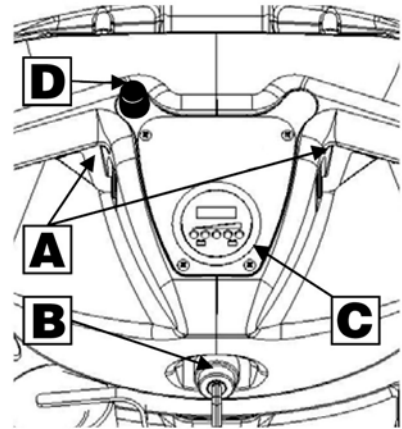

12. REAR COMPONENTS

The rear components are identified as follows:

- A. Foot pedal to raise the brushes
- B. Water / solution level hose
- C. Drain hose with recovery tank cap
- D. Latch to close the tanks
- E. Compartment storage
- F. Lever to raise the squeegee
- G. Solution filter

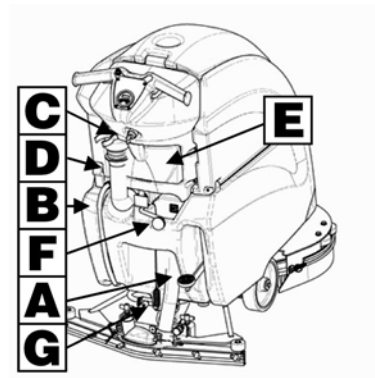

13. SIDE COMPONENTS

The side components are identified as follows:

- A. Valve for manual regulation of clean water flow
- B. Handle to raise the recovery tank
- C. Handle to raise the vacuum unit
- D. Upper storage compartment
- E. Brake lever

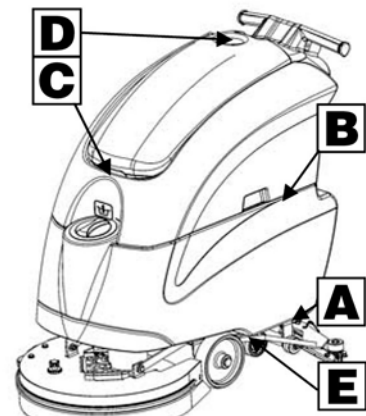

14. ASSEMBLING THE SQUEEGEE

For packaging reasons, the squeegee is supplied dismantled from the machine, and must be assembled as follows:

- A. Insert the two small pins of the squeegee in the appropriate holes on the squeegee yoke.
- B. Insert the two cotter pins chained to the squeegee shoe.
- C. Attach the squeegee vacuum hose over the squeegee shoe adapter.

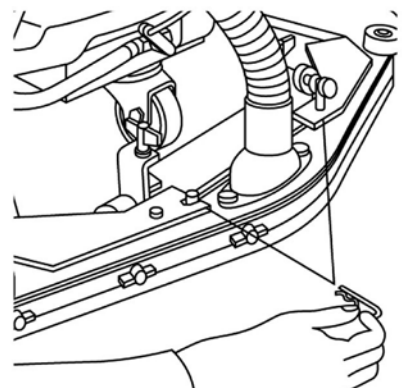

MACHINE PREPARATION

15. ADJUSTING THE SQUEEGEE HEIGHT

The height of the squeegee must be adjusted based on wear of the squeegee blade. To do this, turn the knobs **(2)** counter clockwise to raise the squeegee, and clockwise to lower it.

Note: the right and left wheels must be adjusted to the same level, so the squeegee can work parallel to the floor.

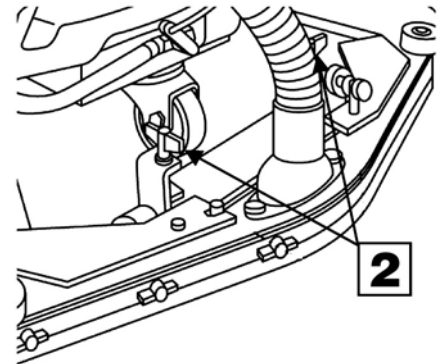

16. ADJUSTING THE SQUEEGEE INCLINATION

During operation, the rear squeegee blade is slightly tilted backwards (by about 0.2 in. (5 mm) in a uniform way over entire length. If it is necessary to increase the bend of the squeegee blade in the center, you must tilt the squeegee backwards, rotating the adjuster **(1)** counter clockwise. To increase the bend of the squeegee blade at the outside edges of the squeegee, rotate the adjuster clockwise. When fully adjusted, tighten the jam nut.

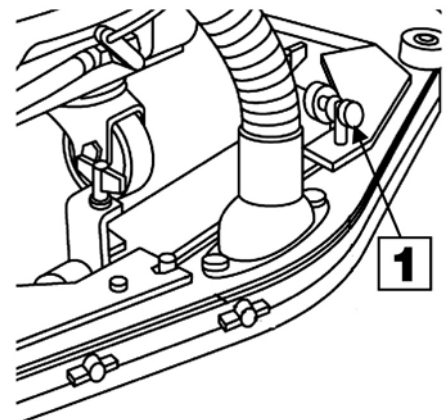

17. RECOVERY TANK

Check the drain hose cap (on the rear of the machine) to ensure it's closed.

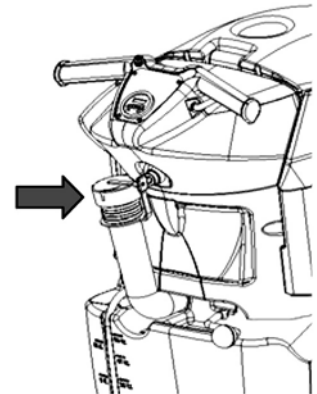

MACHINE PREPARATION

18. SOLUTION TANK

Remove the front inlet cap and check the solution filter is correctly installed. Check the filter cap (beneath the solution tank, at the back) is correctly closed.

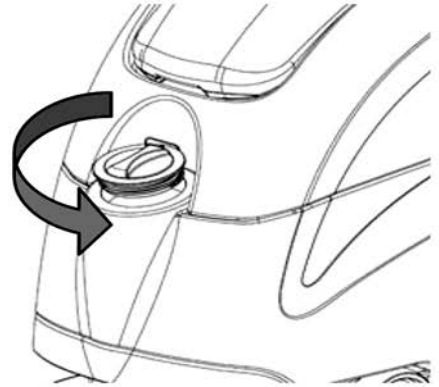

19. SOLUTION TANK

Fill the tank with clean water in the front fill location (1) at a temperature not exceeding 120°F (50°C). You can check the level of solution in the tank by means of the rear hose (2).

Add liquid detergent into the tank, in the concentration and manner specified by the manufacturer. The formation of excess foam could damage the vacuum motor, so be sure to use only the correct amount of detergent.



WARNING: Always use low-foam detergent. Introduce a small amount of defoaming liquid in the recovery tank before starting work to prevent foam from being generated.

WARNING: Never use pure acids.

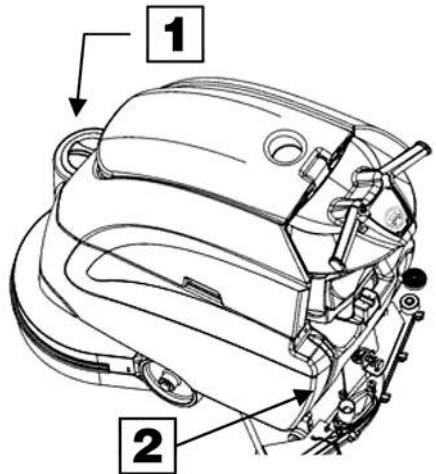

20. ASSEMBLING THE BRUSH

- A. With the brush deck up, place the brush and center it under the brush deck.
- B. Lower the brush deck, turn the key (1) to position "1", pull the switch levers (2) on the handlebars.

The brush is now installed.



WARNING: Make sure there are no objects or people in the vicinity of the brush when doing this operation.

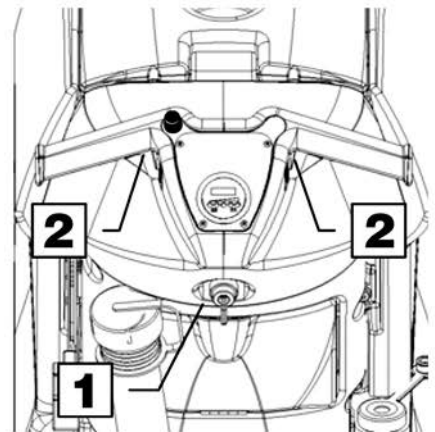

OPERATION

1. MACHINE OPERATION

A. Connect the battery plug to the machine plug.

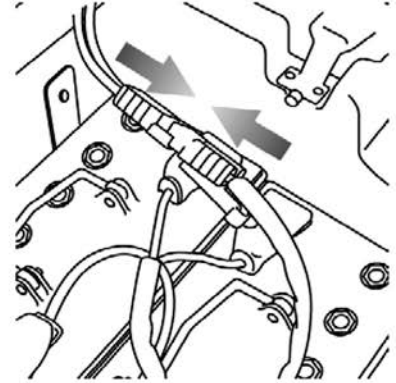

B. Turn the key (1) of the main switch to the "ON" position (clockwise). The battery charge level indicator lights will immediately come on.

C. Turn on the water valve (2) (the water dispenses automatically when the brush is turning).

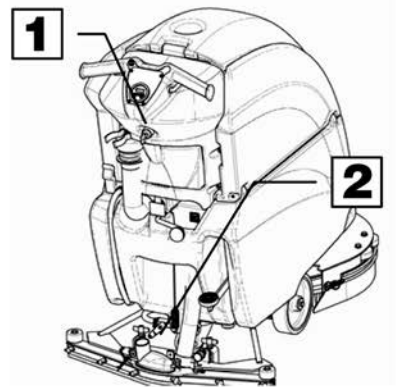

D. Release the foot lever (3) and lower the brush deck.

E. Lower the squeegee by rotating the squeegee lift handle (4) counter clockwise. The vacuum motor will turn on.

F. Check that the brake (5) is released.

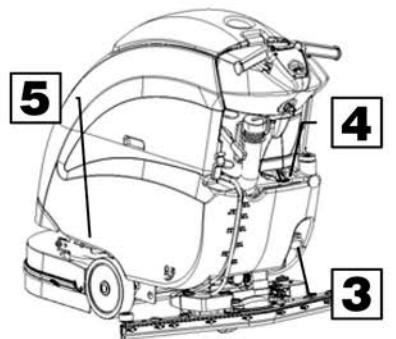

G. Pulling the switch levers (1), activates the brush and the machine begins to move. During the first few feet, check that the amount of solution dispensed is correct, and that the squeegee dries the floor.

H. The machine will now start to scrub and dry until the solution tank is empty or recovery tank is full.

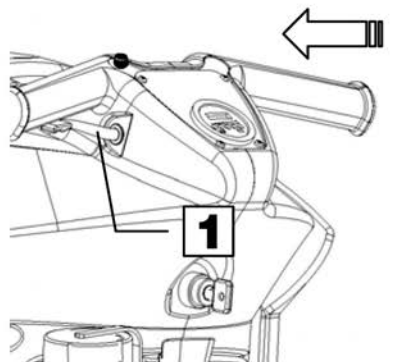

OPERATION

2. REVERSE MOVEMENT

To move the machine in reverse push the switch levers (1) forward.



WARNING: *When moving the machine in reverse, raise the squeegee.*

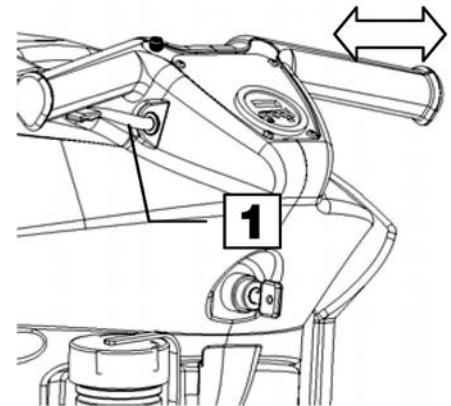

3. OVERFLOW DEVICE

The machine has a float in a filter basket that trips when the recovery tank is full to stop airflow into the vacuum hose.

At this point empty the recovery tank by removing the cap of the drain hose.



WARNING: *Always wear gloves when doing this operation to protect yourself from contact with hazardous chemicals.*



SHUTTING DOWN THE MACHINE

1. END OF WORK

When shutting down the machine and before you perform any type of maintenance:

- A. Turn off the solution control valve (1)
- B. Raise the brush deck using the foot pedal (2)
- C. Raise the squeegee using the squeegee lift lever (3)
- D. Turn off the key switch (4)
- E. Move the machine where the tanks can be drained.

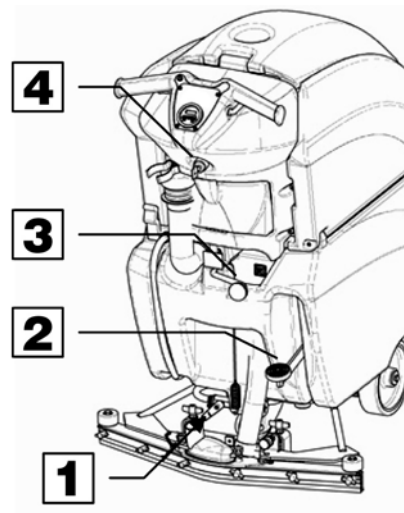

- F. Remove the drain hose from its hook, remove the drain cap and empty the recovery tank.
- G. The squeegee must be raised when the machine is not operating, to avoid deforming the squeegee blades.
- H. Disassemble the pads and clean them with water.



WARNING: Always wear gloves when doing this operation to protect yourself from contact with hazardous chemicals.

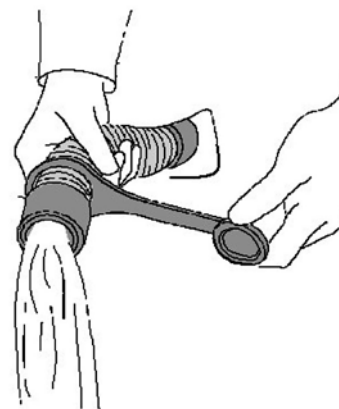

DAILY MAINTENANCE

1. CLEANING THE RECOVERY TANK

- Raise the vacuum cover (1).
- Remove the drain hose (2) from its hook and empty the tank.
- Rinse the inside of the tank with water.
- Close the cover on the machine and replace the drain hose cap and drain hose.



WARNING: Always wear gloves when doing this operation to protect yourself from contact with hazardous chemicals.

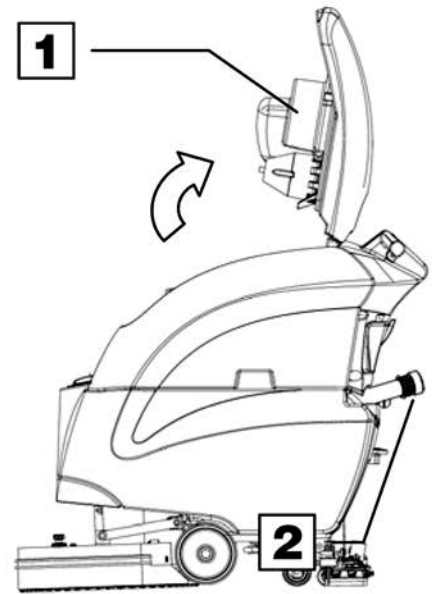

2. CLEANING THE VACUUM FILTER

- Raise the cover.
- Remove the vacuum filter cover by rotating it clockwise.
- Pull the filter straight down from the lid to remove it.
- Use water to clean the walls and base of the filter.
- Reassemble all the components.



WARNING: Always wear gloves when doing this operation to protect yourself from contact with hazardous chemicals.

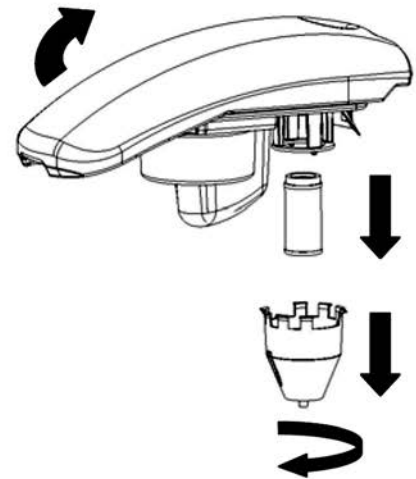

3. CLEANING THE VACUUM HOSE FILTER

- Raise the vacuum cover.
- Rotate the inner filter (1) and remove it.
- Use water to clean the walls and base of the filter.
- Reassemble all the components.



WARNING: Always wear gloves when doing this operation to protect yourself from contact with hazardous chemicals.

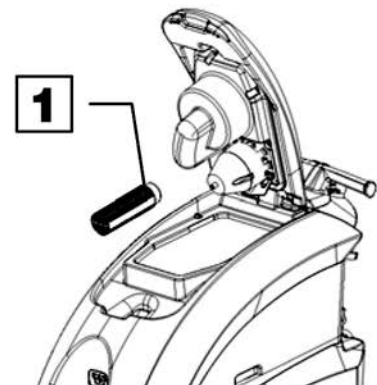

DAILY MAINTENANCE

4. CLEANING THE SQUEEGEE

To clean:

- A. Remove the vacuum hose from the squeegee shoe adaptor.
- B. Loosen the knobs (1) at the squeegee shoe adaptor.
- C. Remove and clean the squeegee shoe adaptor.
- D. Carefully clean inside the squeegee shoe.
- E. Carefully clean the squeegee blades.
- F. Reassemble all the squeegee components.

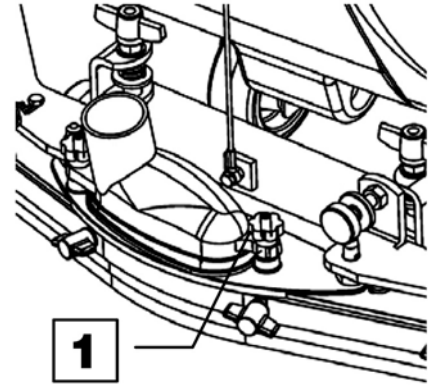

5. MOVING THE PAD DRIVER

To remove the pad driver:

- A. Turn on the machine with the key switch.
- B. Press the foot pedal that raises and lowers the brush deck, and slightly raise the pad off the floor (1).
- C. Pull the switch levers (2) then release them immediately.
- D. The pad driver will be automatically release from the brush deck.

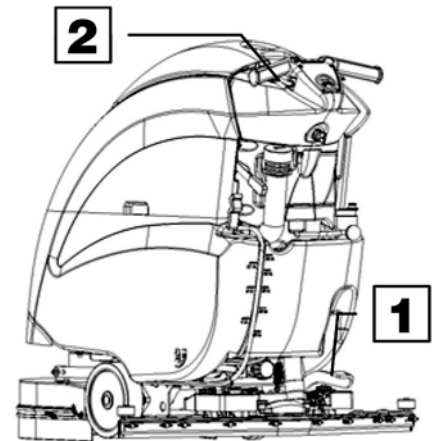

6. REPLACING THE SQUEEGEE BLADES

Check the wear of the squeegee blades and, if necessary, replace them.

To replace them:

- A. Remove the vacuum hose from the squeegee shoe adaptor.
 - B. Remove the cotter pins that mount the squeegee shoe.
 - C. Remove the squeegee shoe from the squeegee yoke.
 - D. Loosen the wing nuts (1).
 - E. Remove the squeegee band clamp and squeegee blade.
 - F. Replace the squeegee blades.
- To reassemble the squeegee, repeat the operations in the reverse order.

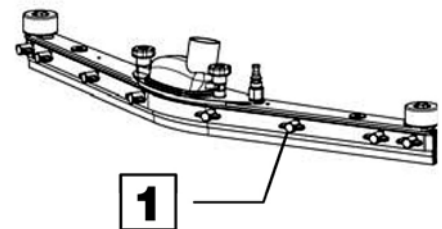

WARNING: Always wear gloves when doing this operation to protect yourself from contact with hazardous chemicals.

WEEKLY MAINTENANCE

1. CLEANING THE SQUEEGEE HOSE

Every week, or whenever vacuum seems to be unsatisfactory, check the squeegee hose for obstructions. To clean it:

- A. Remove the vacuum hose from the squeegee shoe adapter on the squeegee shoe.
- B. Remove the other end from the recovery tank.
- C. Wash the inside of the hose with water from the end that it is connected to the tank.
- D. Reassemble the hose.



WARNING: Always wear gloves when doing this operation to protect yourself from contact with hazardous chemicals.

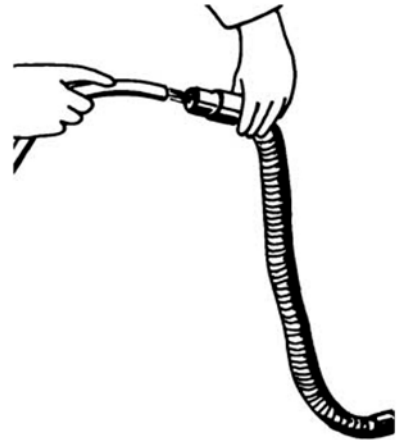

2. CHECKING THE BRAKE

Every week, check the distance between the work brake pads and the wheels. If necessary, adjust so they are at a distance of 0.12 in (3 mm) when released.

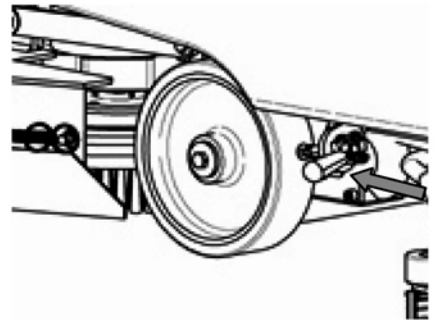

3. CLEANING THE SOLUTION TANK

- A. Remove the solution tank cap.
- B. Rinse with water.
- C. Remove the drain cap (1) located on the filter, and empty the tank.



WARNING: Always wear gloves when doing this operation to protect yourself from contact with hazardous chemicals.

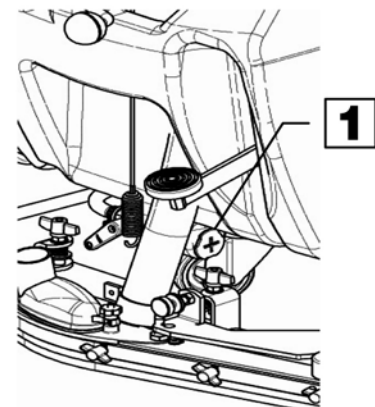

TROUBLESHOOTING GUIDE

INSUFFICIENT WATER ON THE PAD

1. Check the valve – located beneath the symbol – (1) is turned on.
2. Check there is water in the solution tank.

THE MACHINE DOES NOT CLEAN WELL

1. Check the wear of the scrubbing pad and, if necessary, replace it.

THE SQUEEGEE DOES NOT DRY WELL

1. Check that the squeegee blades are clean.
2. Adjust the inclination of the squeegee.
3. Ensure the vacuum hose is correctly inserted in its housing in the recovery tank.
4. Check the inner filter inside the recovery tank to ensure that it is clean and, if necessary, clean it thoroughly.
5. Disassemble the entire vacuum unit and clean it.
6. Replace the squeegee blades, if worn.
7. Check squeegee wheel adjustment.

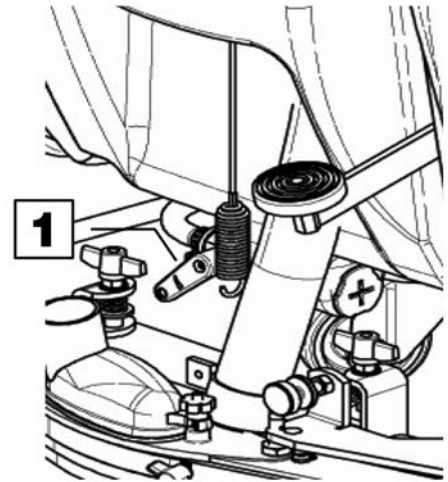

TOO MUCH FOAM IS GENERATED

Check that low-foam detergent is being used. If necessary add a small amount of defoamer liquid to the recovery tank. Remember that more foam is generated when the floors are not very dirty. Dilute the detergent more when cleaning floors that are not very dirty.

CHOOSING AND USING THE BRUSHES

POLYPROPYLENE BRUSH (PPL)

Used on all types of floors. Good resistance to wear and tear, and hot water (no greater than 140°F (60°C)).

NYLON BRUSH

Used on all types of floors. Excellent resistance to wear and tear and hot water (even over 140°F (60°C)).

ABRASIVE BRUSH

The bristles of this type of brush are coated with highly aggressive abrasives. It is used to clean very dirty floors.

THICKNESS OF THE BRISTLES

Thicker bristles are more rigid and are therefore used on smooth floors or floors with small joints. On uneven floors or those with deep joints, it is advisable to use softer bristles which can enter the gaps easier. Remember that when the bristles are worn and too short, they will become rigid and are no longer able to penetrate and clean deep and cause the brush to bounce.

PAD DRIVER

A pad driver is recommended for cleaning smooth surfaces. There are two types of pad drivers:

1. The traditional pad holder is fitted with a series of anchor points that allow the abrasive floor pad to be held while working.
2. The CENTER LOCK type pad holder not only has anchor points, but also a snap-type central locking system made of plastic that allows the abrasive floor pad to be centered and held without any risk of it becoming detached.

BRUSH DECK DIAGRAM

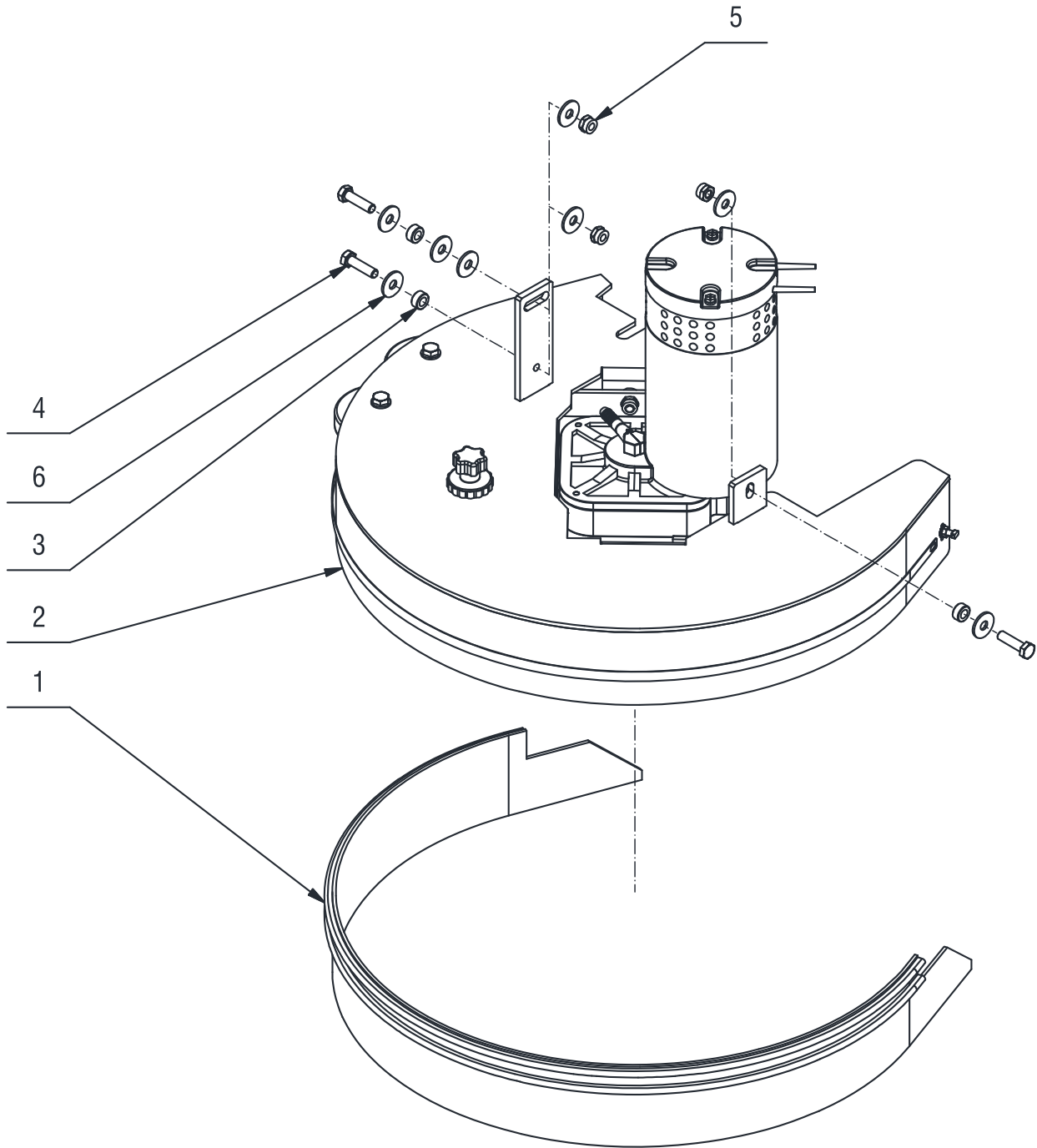

BRUSH DECK PARTS LISTING

Item#	Part #	Description	Qty.
1	E88272	Brush Deck Splash Guard	1
2	E20073	Brush Deck	1
3	E83970	Bushing	3

Item#	Part #	Description	Qty.
4	E83802	Hex Bolt M8x30 Zinc	3
5	E81709	Nyloc Hex Nut, M8 Zinc	3
6	E83404	Flat Washer M9x24x2.5 Zinc	8

BRUSH DECK DRIVE DIAGRAM

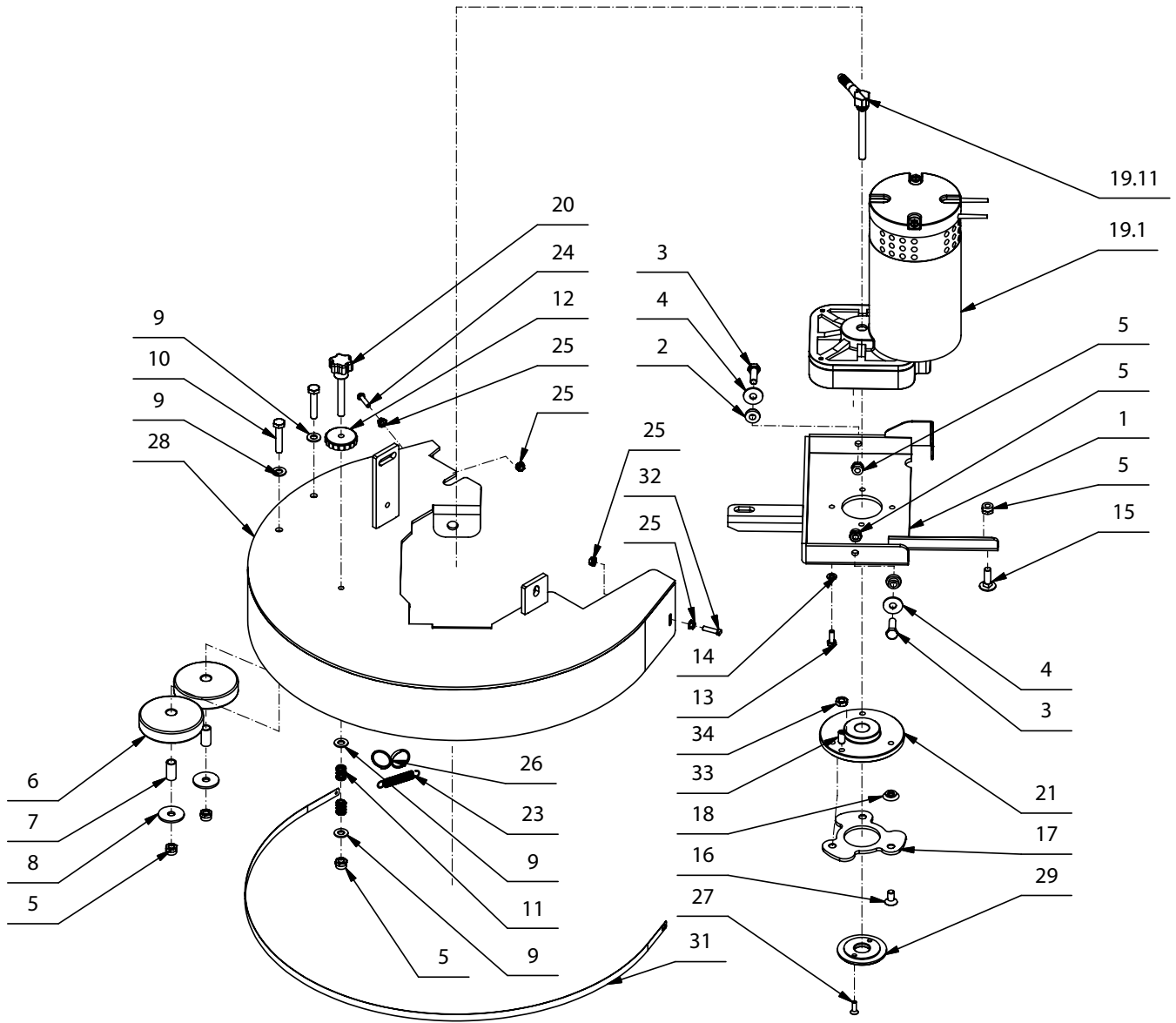

BRUSH DECK DRIVE PARTS LISTING

Item#	Part #	Description	Qty.
1	E20011	Motor Mount Plate	1
2	E82312	Bushing	2
3	E83833	Hex Bolt M8x25 Zinc	2
4	E83404	Flat Washer M9x24x2.5 Zinc	2
5	E81709	Nyloc Hex Nut, M8 Zinc	6
6	E83895	Wheel 80 OD x 23 W	2
7	E83524	Bushing	2
8	E81918	Flat Washer M9x32x2.5 Zinc	2
9	E81874	Flat Washer M8x17x1.6 Zinc	4
10	E83830	Hex Bolt M8x40 Zinc	2
11	E82309	Spring, Compression	2
12	E83331	Knob	1
13	E83547	M6x16 Bolt, Zinc Hex Head 4	
14	E82774	Lock Washer, M6 Zinc	4
15	E20093	Carriage Bolt M8x25 Zinc	1
16	E20297	Flat Hd Soc Machine Screw M8x16 Zinc	3
17	E82844	Clutch Plate	1

Item#	Part #	Description	Qty.
18	E82845	Spacer	3
19	E88245	Motor, Geared 24V 400W 140 RPM	1
19.11	E20451	Fitting, Solution Delivery Tube	1
20	E83565	Knob	1
21	E88246	Brush, Flange Threaded	1
23	E83491	Spring	1
24	E83881	Hex Bolt M5x20 Zinc	1
25	E88010	Hex Nut, M5	4
26	E83489	Rings	1
27	E20290	Flat Hd Soc Machine Screw M5x16 SS	2
28	E20507	Brush Deck	1
29	E20584	Retainer	1
31	E86169	Band Clamp	1
32	E83823	Screw M5x20/ SS Custom	1
33	E20592	Dowel Pin M8	1
34	E83672	Hex Jam Nut, M8x5 SS	1

SQUEEGEE ASSEMBLY DIAGRAM

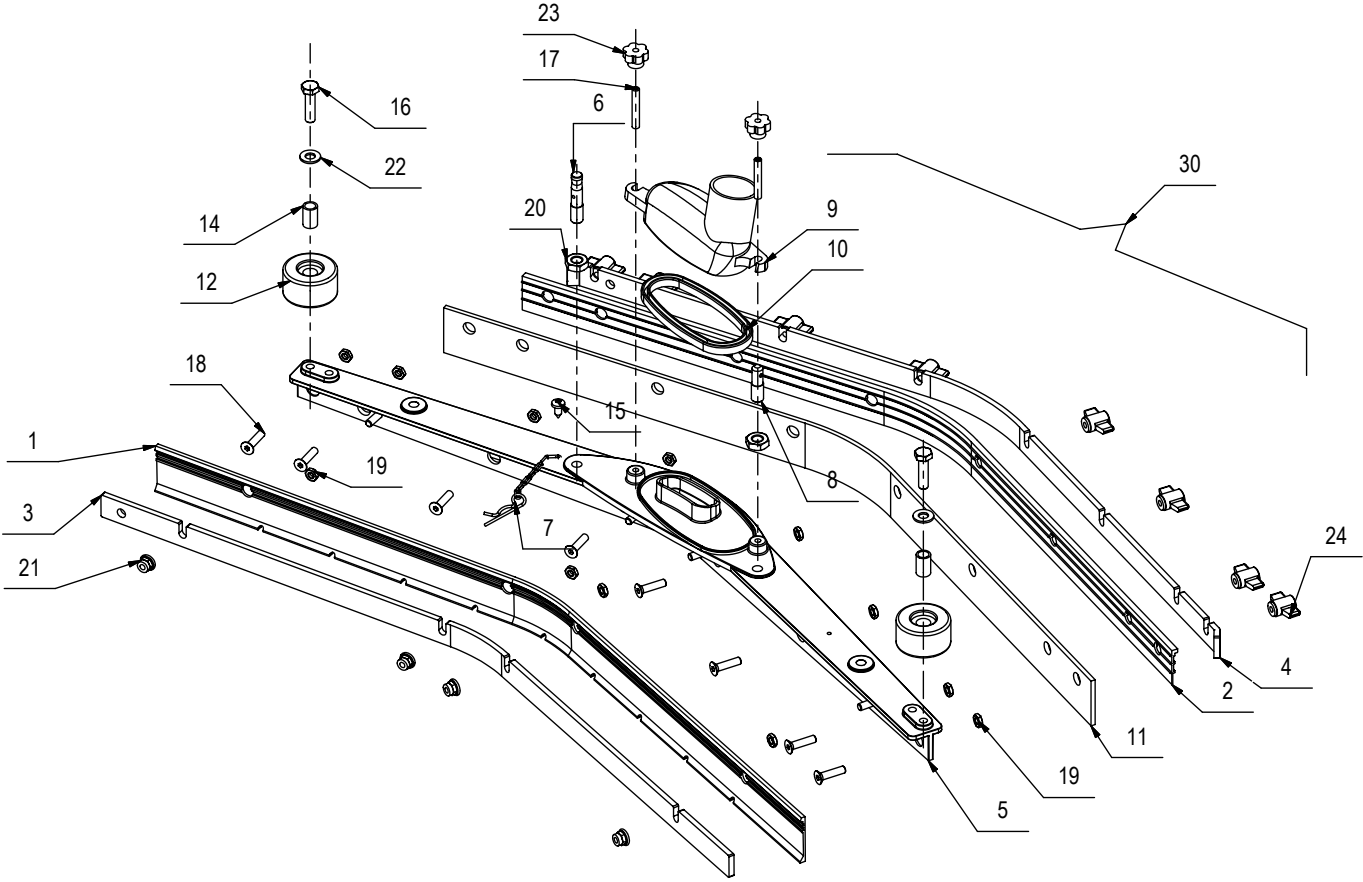

SQUEEGEE ASSEMBLY PARTS LISTING

Item#	Part #	Description	Qty.
1	E83909	Squeegee Blade, Polyurethane 30" x 1 3/4" x 1/8"	1
2	E12560	Squeegee Blade, Polyurethane 30 3/4" x 1 3/4" x 1/8"	1
3	E82608	Band Clamp 29 1/2" x 7/8" x 1/8"	1
4	E82676	Band Clamp 31 1/4" x 7/8" x 1/8"	1
5	E88240	Squeegee Body	1
6	E83911	Stud Bolt M10x46 Custom	1
7	E83590	Chain	1
8	E83945	Stud Bolt M10x33 Custom	1
9	E82307	Squeegee Vacuum Adapter	1
10	E83971	Gasket	1
11	E12686	Squeegee Blade, Gum Rubber 30 3/4" x 1 3/4" x 1/8"	1
12	E82451	Wheel 45 OD x 25 W	2
13	E83914	Hex Bolt M6x20 SS	2

Item#	Part #	Description	Qty.
14	E82253	Bushing, Brass OD 11.95mm x ID 8.9mm x L 8.45mm	1
15	E83851	Screw, Pan Hd Phil Self Tap M5.5x13 SS	2
16	E83802	Hex Bolt M8x30 Zinc	2
17	E82707	Set Screw Hex Soc Flat End M6x40 SS	8
18	E81848	Flat Hd Soc Machine Screw M6x25 SS	12
19	E20114	Hex Jam Nut, M6X3 SS	2
20	E83875	Hex Jam Nut, M10X6 Zinc	4
21	E20117	Nyloc Hex Jam Nut, M6x9 SS	2
22	E81874	Flat Washer M8x17x1.6 Zinc	2
23	E83810	Knob	8
24	E83591	Knob	1
30	E88536	Squeegee Assembly	1

SQUEEGEE YOKE DIAGRAM

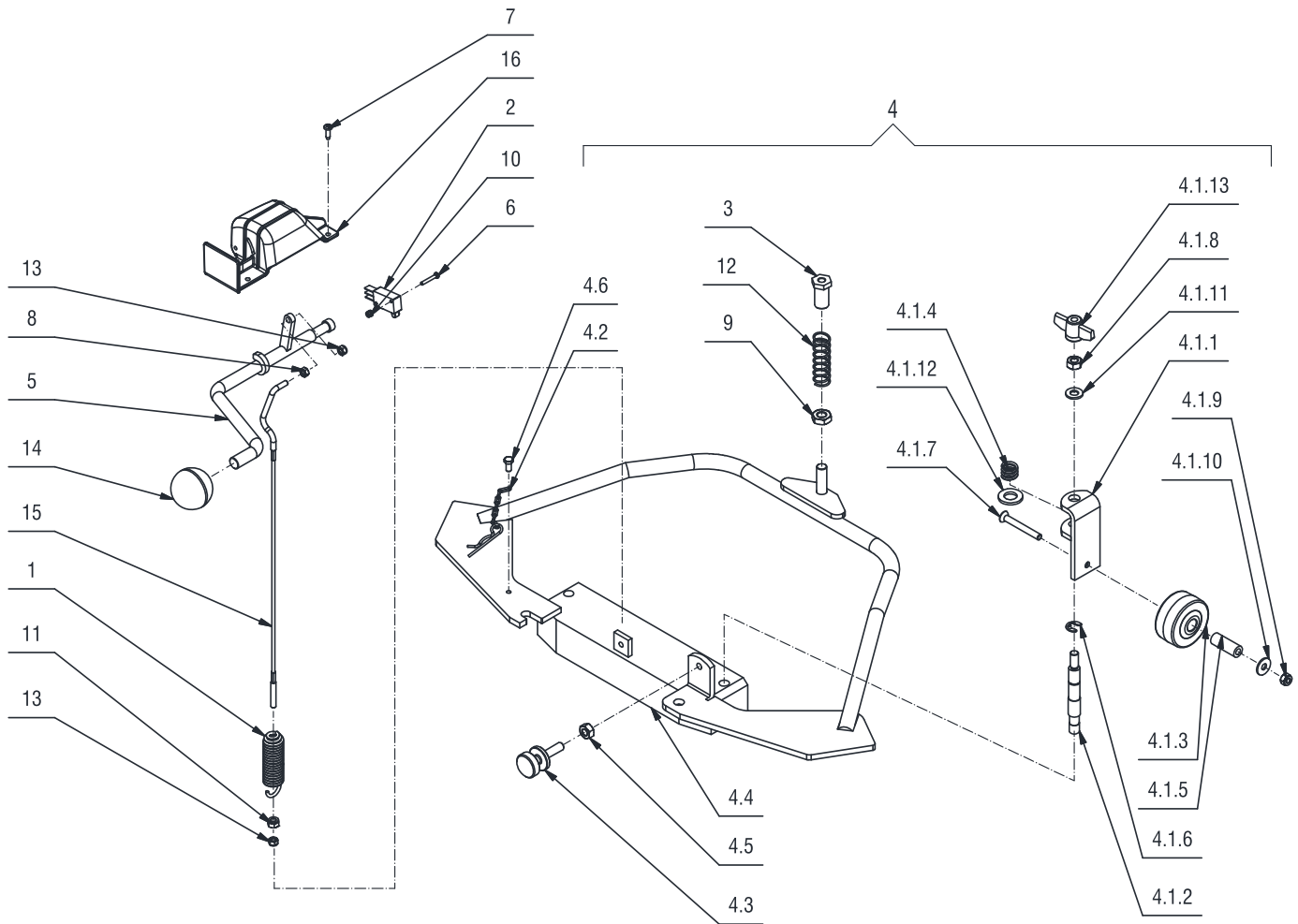

SQUEEGEE YOKE PARTS LISTING

Item#	Part #	Description	Qty.
1	E82279	Spring	1
2	E88279	Micro Switch Sealed	1
3	E20373	Guide Bushing	1
4	E20227	Squeegee Yoke ASM	1
4.1	E20644	Squeegee Wheel Support ASM	2
4.1.1	E85497	Weldment, Squeegee Wheel Support	1
4.1.2	E82329	Threaded Pin	1
4.1.3	E82428	Wheel 52 OD x 28 W	1
4.1.4	E81634	Spring Compression	1
4.1.5	E82273	Bushing	1
4.1.6	E85498	E Style Circlip	1
4.1.7	E20246	Flat Hd Soc Machine Screw M6x50 Zinc	1
4.1.8	E83656	Hex Nut, M8x6.5 Zinc	1
4.1.9	E83550	NyLoc Hex Nut, M6 Zinc	1
4.1.10	E82798	Flat Washer M6x18x1.5 Zinc	1
4.1.11	E81874	Flat Washer M8x17x1.6 Zinc	1
4.1.12	E85722	Flat Washer M13x24x2.5 Zinc	1
4.1.13	E83531	Knob	1

Item#	Part #	Description	Qty.
4.2	E83590	Chain	1
4.3	E83655	Adjuster Knob	1
4.4	E20286	Squeegee Yoke	1
4.5	E85499	Hex Nut, M8x6.5 SS	1
4.6	E20134	Hex Bolt M5x10 Zinc	1
5	E20408	Squeegee Lift Lever	1
6	E20242	Pan Hd Phil Machine Screw M3x20 Zinc	2
7	E83838	Screw 4.2 X 13	4
8	E82317	Hex Jam Nut, M5X3.5 Zinc	1
9	E83875	Hex Jam Nut, M10X6 Zinc	1
10	E81673	Hex Nyloc Nut, M3 Zinc	2
11	E83550	NyLoc Hex Nut, M6 Zinc	1
12	E88248	Spring 17 x 14 x 53 Wide D=1.5	1
13	E20382	Nyloc Hex Nut, M5x5 Zinc	2
14	E20638	Knob	1
15	E88250	Squeegee Lift Cable	1
16	E20641	Bracket	1

MAIN FRAME PARTS LISTING

Item#	Part #	Description	Qty.
1	E82834	Pivot Block	6
2	E81735	Hex Bolt M12x35 Zinc	1
3	E83829	Hex Jam Nut, M12X7 Zinc	1
4	E83550	NyLoc Hex Nut, M6 Zinc	10
5	E81738	Flat Washer M4x12x3 Zinc	1
7	E83669	Pedal cover	1
8	E20370	Foot Pedal	1
9	E82761	Flat Washer M6x12x1.6 Zinc	10
10	E86182	Drive Motor 24VDC 150W	1
10/A	E20523	Carbon Brush	2
11	E88253	Bushing	4
12	E20014	Bearing Mount Cap	2
13	E20609	Bearing Mount Base	2
14	E20315	Shim Plate	2
15	E20591	Carriage Bolt M8x100 Zinc	4
16	E81657	Bearing	2
17	E81709	Nyloc Hex Nut, M8 Zinc	4
18	E82798	Flat Washer M6x18x1.5 Zinc	2
19	E82774	Flat Washer M6x12x1.6 SS	2
20	E81983	Hex Bolt M6x40 Zinc	4
21	E20446	Axle Shaft, Right	1
22	E20458	Axle Shaft, Left	1
23	E88254	Spacer 25 x 20 x 31	2
24	E81915	Flat Washer M8.2x32x4 Zinc	2
25	E81917	Hex Bolt M8x20 Zinc	2

Item#	Part #	Description	Qty.
26	E20071	Clamp Plate	1
27	E20501	Splash Guard	1
28	E20108	Screw, Pan Hd Phil Self Tap M4.8x16 SS	2
29	E83578	Soc Hd Cap Screw M6x25 Zinc	2
30	E20369	Parking Brake	1
31	E20356	Carriage Bolt M6x20 Zinc	1
32	E83852	Hex Nut, M6x5	1
33	E82542	Drive Wheel 175 OD x 45 W	2
34	E20226	Bumper	1
36	E85722	Flat Washer M13x24x2.5 Zinc	2
37	E20334	Bumper	1
50	E88256	Micro Switch	1
38	E20600	Main Frame Weldment	1
39	E83597	Brush Deck Lift Idler Arm Weldment	1
40	E20473	Switch Plate	1
41	E20435	Nyloc Hex Nut, M3 SS	2
42	E20242	Pan Hd Phil Machine Screw M3x20 Zinc	2
43	E20388	Brush Deck Lift Arm Weldment	1
44	E20437	Castor	1
46	E20380	Soc Hd Cap Screw M12x30 Zinc	2
47	E20246	Flat Hd Soc Machine Screw M6x50 Zinc	2
48	E20255	Flat Hd Soc Machine Screw M6x45 Zinc	4
49	E82773	Flat Washer M10x21x2 Zinc	1
50	E88256	Micro Switch	1

SOLUTION TANK DIAGRAM

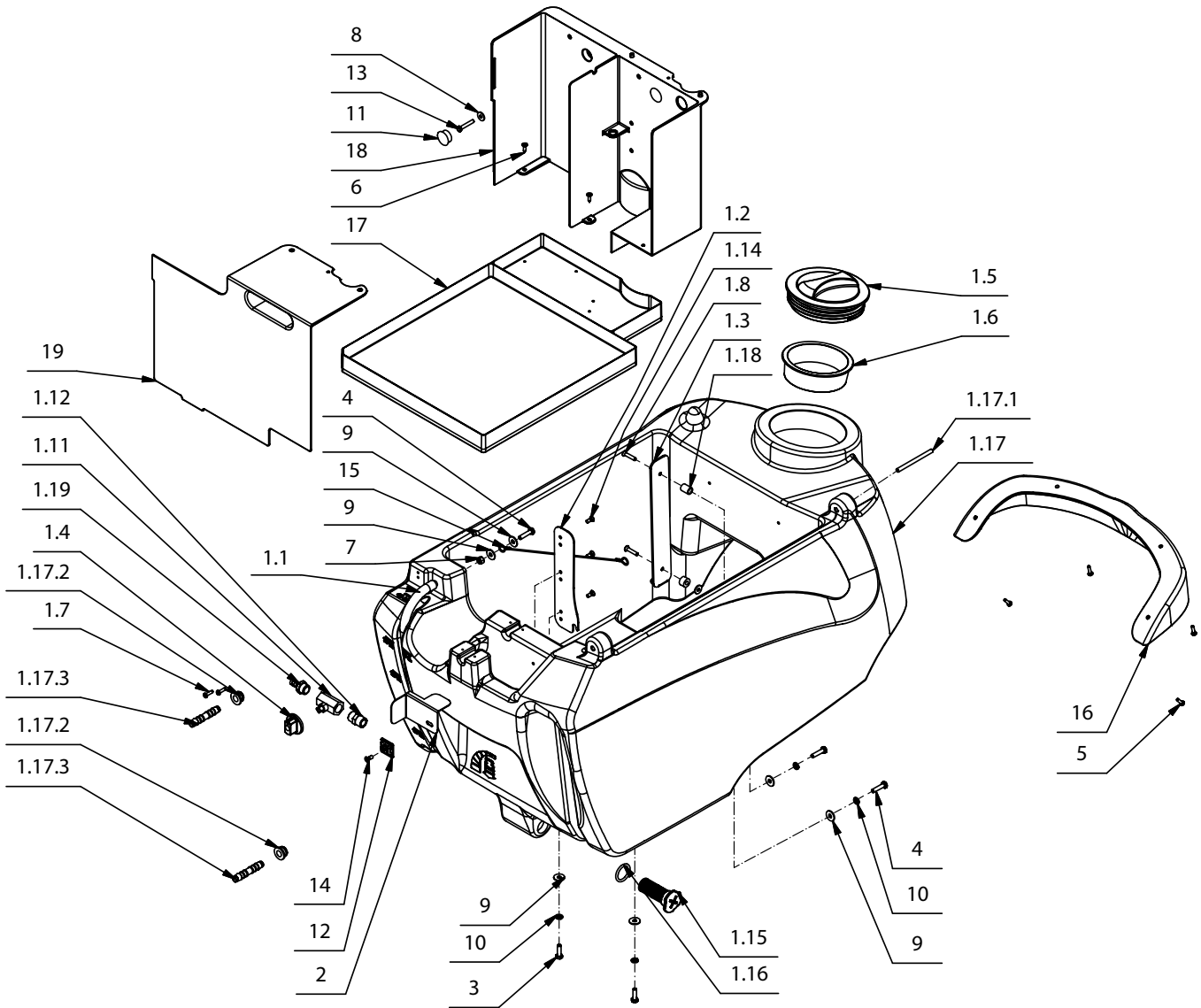

SOLUTION TANK PARTS LISTING

Item#	Part #	Description	Qty.
1	E20285	Solution Tank ASM	1
1.1	E88258	Hose, Glass Reinforced 15 OD x 10 ID x 496 L	1
1.2	E20409	Foot Pedal Latch Plate	1
1.3	E20611	Guard Plate	1
1.4	E86145	Knob	1
1.5	E82429	Cap	1
1.6	E82612	Filter	1
1.7	E20107	Screw, Pan Hd Phil Self Tap M4.2x16 SS	2
1.8	E20110	Flat Hd Soc Machine Screw M5x25 SS	2
1.9	E20122	Flat Washer M5 x 15 x 1.5 SS	1
1.10	E85762	Hose Clamp	1
1.11	E83361	Ball Valve	1
1.12	E83943	Nipple, Double Female 3/8"	1
1.13	E81981	Spacer	1
1.14	E20468	Flat Hd Phil Machine Screw M5x12 Zinc	3
1.15	E88259	Filter, Water 23 x 53 Plug 3/4"	1
1.16	E88261	Flat Washer M8.2x32x4 Zinc	1
1.17	E20197	Solution Tank, Gray	1
1.17.1	E20389	Hinge Pin	1
1.17.2	E20271	Grommet	2
1.17.3	E20196	Fitting, Barbed	2

Item#	Part #	Description	Qty.
1.18	E20577	Spacer	1
1.19	E20602	Fitting, Barbed Threaded	1
2	E20411	Bracket	1
3	E82772	Hex Bolt M6x20 Zinc	2
4	E20090	Hex Bolt M6x25 Zinc	3
5	E20392	Pan Hd Phil Machine Screw M4x16 Zinc	4
6	E83796	Screw, Pan Hd Phil Self Tap M4.2x16 Zinc	5
7	E20112	Hex Nut, M6x6 Zinc	1
8	E20121	Flat Washer M5x15x1.5 Zinc	2
9	E82798	Washer, 6x18x1.5	6
10	E82774	Lock Washer, M6 Zinc	4
11	E20708	Cover, Bolt	2
12	E81619	Support Bracket	1
13	E20359	Hex Bolt M5x30 Zinc	2
14	E20468	Flat Hd Phil Machine Screw M5x12 Zinc	1
15	E88260	Lanyard	1
16	E20438	Bezel	1
17	E20709	Battery Tray	1
18	E20710	Housing, Plastic	1
19	E20711	Housing Cover, Plastic	1

RECOVERY TANK DIAGRAM

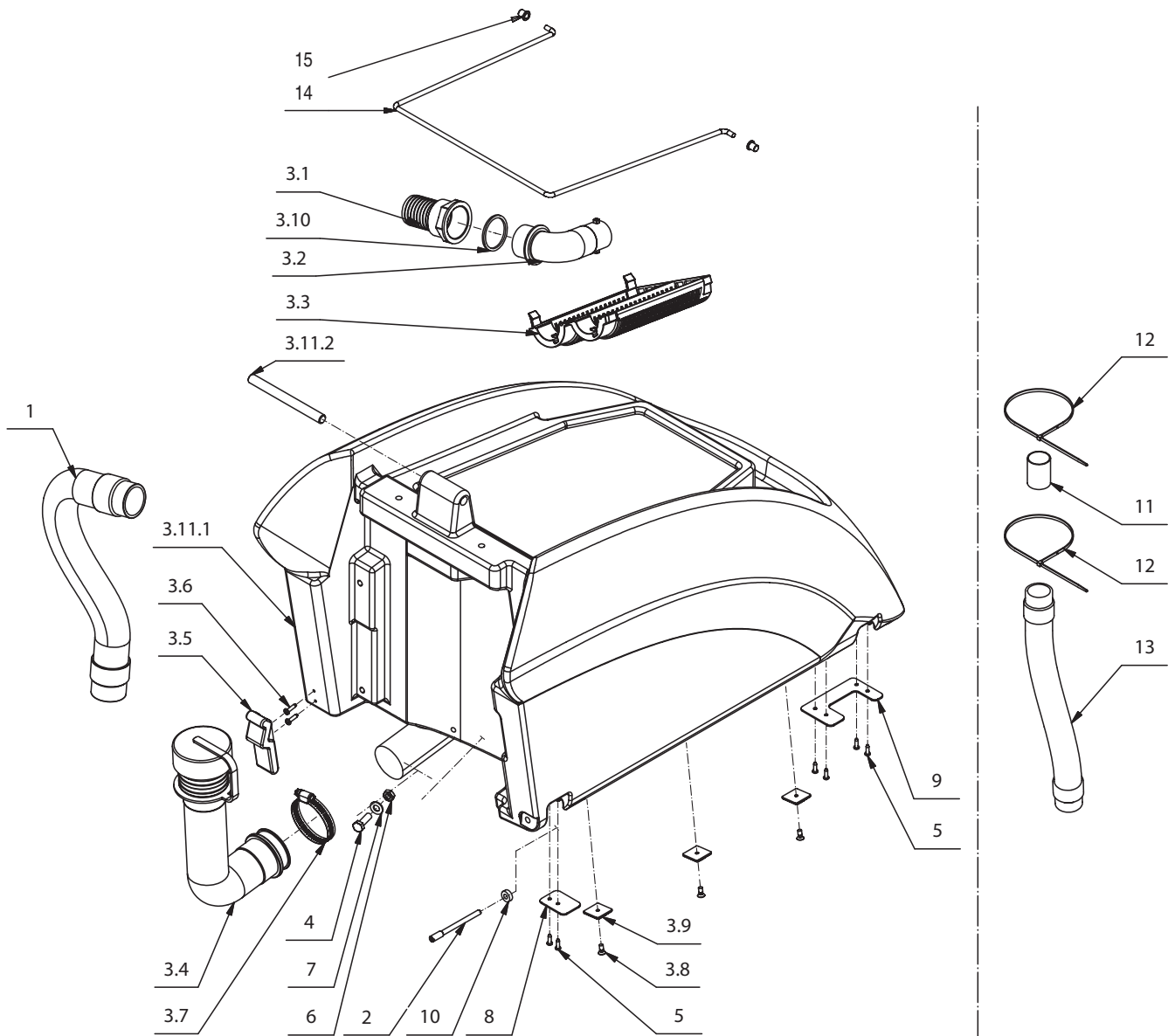

RECOVERY TANK PARTS LISTING

Item#	Part #	Description	Qty.
1	E88499	Hose, Vacuum	1
2	E20074	Hinge Pin	1
3	E20354	Recovery Tank ASM	1
3.1	E20189	Fitting, Barbed	1
3.2	E20186	Elbow	1
3.3	E88285	Filter, Cage	1
3.4	E88286	Hose, Drain	1
3.5	E20413	Latch	1
3.6	E20107	Screw, Pan Hd Phil Self Tap M4.2x16 SS	2
3.7	E20707	Clamp, Hose M40-64 Zinc	1
3.8	E20468	Flat Hd Phil Machine Screw M5x12 Zinc	3
3.9	E81619	Cable Tie Holder	3
3.10	E82341	Gasket	1
3.11.1	E20198	Recovery Tank, Red	1

Item#	Part #	Description	Qty.
3.11.2	E20188	Hinge Pin	1
4	E83833	Hex Bolt M8x25 Zinc	1
5	E82638	Screw, Pan Hd Phil Self Tap M3.9x13 SS	6
6	E82808	Hex Jam Nut, M8X5 Zinc	1
7	E20127	Flat Washer M9x18x1.5 Zinc	1
8	E20563	Plate	1
9	E20195	Plate	1
10	E20524	Spacer, Nylon	1
11	E88500	Fitting, Hose D38, W1.5, L50	1
12	E83920	Clamp 9x300 4,8x360 black	2
13	E88499	Hose, Vacuum	1
14	E22072	Bale, Vac Lid	1
15	E22074	Plug, Vac Lid Bale	2

VACUUM UNIT DIAGRAM

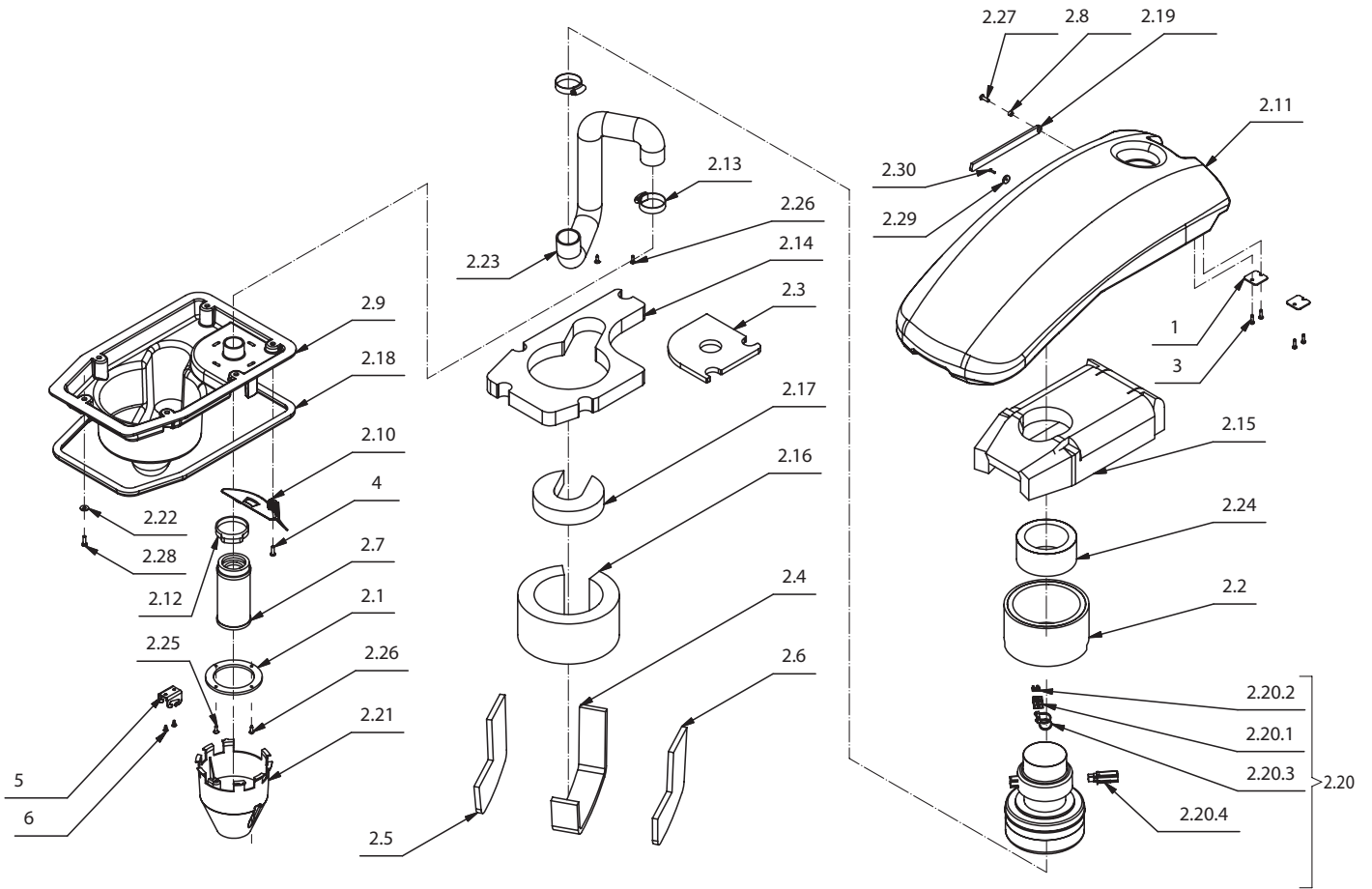

VACUUM UNIT PARTS LISTING

Item#	Part #	Description	Qty.
1	E20265	Plate	2
2	E20066	Recovery Tank Cover ASM	1
2.1	E20305	Mounting Ring	1
2.2	E20652	Sound Deadening Foam	1
2.3	E20180	Sound Deadening Foam	1
2.4	E20179	Sound Deadening Foam	1
2.5	E20178	Sound Deadening Foam	1
2.6	E20266	Sound Deadening Foam	1
2.7	E88292	Filter, Cage	1
2.8	E20486	Bushing	1
2.9	E20384	Vacuum Motor Cover	1
2.10	E20191	Deflector	1
2.11	E20199	Recovery Tank Cover	1
2.12	E81710	Hose Clamp	1
2.13	E20325	Hose Clamp	2
2.14	E20181	Sound Deadening Foam	1
2.15	E20184	Sound Deadening Foam	1
2.16	E20183	Sound Deadening Foam	1
2.17	E20182	Sound Deadening Foam	1
2.18	E88289	Gasket	1

Item#	Part #	Description	Qty.
2.19	E20064	Support Bracket	1
2.20	E88291	Vacuum Motor 36VDC 550W	1
2.20.1	E83897	Connector, Electrical Housing 30A	2
2.20.2	E83883	Lug, Electrical 30A	2
2.20.3	E83935	Wire Tie	2
2.20.4	E20525	Carbon Brush	2
2.21	E81006	Vacuum Splash Guard	1
2.22	E20122	Flat Washer M5 x 15 x 1.5 SS	5
2.23	E88290	Hose, Vacuum	1
2.24	E20440	Sound Deadening Foam	1
2.25	E83796	Screw, Pan Hd Phil Self Tap M4.2x16 Zinc	2
2.26	E83838	Screw, Flat Hd M4x15 Zinc	2
2.27	E20442	Button Hd Soc Machine Screw M5x16 Zinc	1
2.28	E20084	Hex Bolt M5x16 SS	5
2.29	E20712	Magnet	1
2.30	E20192	CHIPBOARD SCREW M3x12 Zinc	1
3	E20107	Screw, Pan Hd Phil Self Tap M4.2x16 SS	4
4	E20298	Soc Button Head Screw M5x16 SS	1
5	E22075	Hook, Vac Lid Bale	1
6	E22076	Screw, M4 x 10	2

SOLUTION DELIVERY PARTS LISTING

Item#	Part #	Description	Qty.
1	E81035	Solenoid Valve	1
2	E85762	Hose Clamp	4
3	E22144	Tubing, 10 ID x 370 L	1
4	E20375	Tubing, 10 ID x 650 L	1

Item#	Part #	Description	Qty.
5	E20602	Fitting, Threaded Barb	1
7	E22145	Fitting, 3/8" - 1/4" Reducer	1
8	E88829	Fitting, 90 Degree Elbow	1

HANDLEBAR DIAGRAM

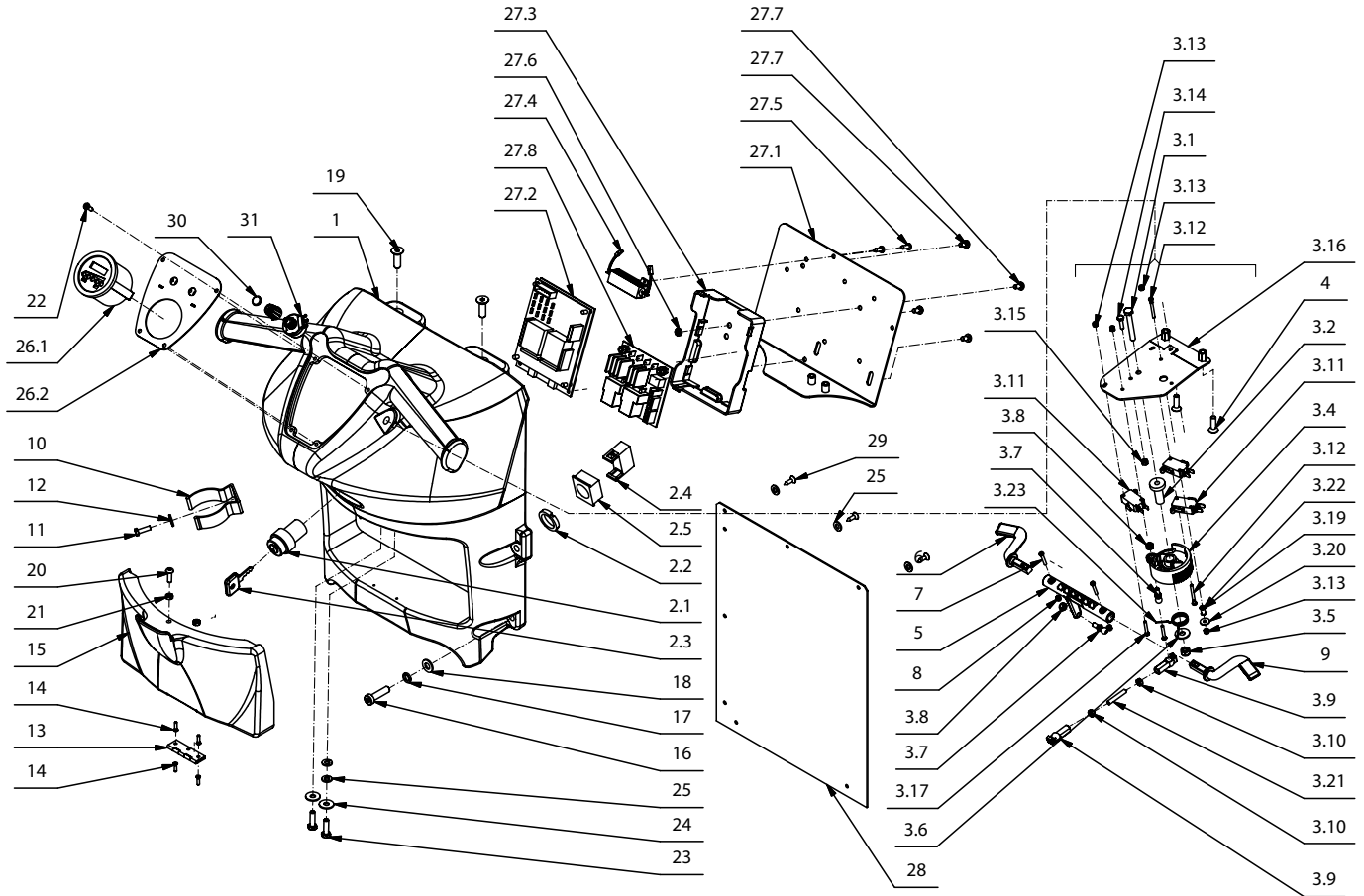

HANDLEBAR PARTS LISTING

Item#	Part #	Description	Qty.
1	E20200	Handlebar Housing	1
2	E82351	Key switch	1
2.1	E83316	Key Switch	1
2.2	E83316	Key Switch	1
2.3	E83315	Switch Key	1
2.4	E83173	Key Switch Contact	1
2.5	E81358	Switch Flange	1
3	E20223	Drive Control	1
3.1	E20360	Hex Bolt M6x45 Zinc	1
3.2	E81597	Circuit Breaker 10 amp 1600-037-100 1/4 in. Tab terminals	1
3.4	E81763	Cam	1
3.5	E83550	NyLoc Hex Nut, M6 Zinc	1
3.6	E82798	Washer, 6x18x1.5	1
3.7	E20330	Pin	2
3.8	E20382	Nyloc Hex Nut, M5 x 5 Zinc	2
3.9	E81625	Ball Stud Receiver	2
3.1	E82317	Hex Jam Nut, M5X3.5 Zinc	2
3.11	E82270	Micro Switch	3
3.12	E20243	Pan Hd Phil Machine Screw M3x30 Zinc	2
3.13	E81673	Hex Nyloc Nut, M3 Zinc	4
3.14	E20341	Hex Bolt M4x16 Zinc	1
3.15	E20248	Hex Nut, M4x4 Zinc	1
3.16	E20556	Plate	1
3.17	E20242	Pan Hd Phil Machine Screw M3x20 Zinc	2
3.19	E20466	Insert	1
3.2	E83037	Flat Washer M4x12x1.6 Zinc	1
3.21	E20362	Set Screw Hex Soc Dog Point M5x30 Zinc	1
3.22	E20469	Flat Washer M3 SS	2
3.23	E82304	Spring	1
4	E20111	Flat Hd Soc Machine Screw M6x20 Zinc	2
5	E88267	Switch Cam	1
6	E88300	Lever, Left Switch	1
7	E20242	Pan Hd Phil Machine Screw M3x20 Zinc	2
8	E81673	Hex Nyloc Nut, M3 Zinc	2

Item#	Part #	Description	Qty.
9	E88301	Lever, Right Switch	1
10	E87296	Drain Hose Clip	1
11	E83836	Hex Bolt M5x16 Zinc	1
12	E20121	Flat Washer M5x15x1.5 Zinc	1
13	E20400	Hinge	1
14	E20192	CHIPBOARD SCREW M3x12 Zinc	4
15	E20267	Door	1
16	E20288	Soc Hd Cap Screw M8x30 Zinc	4
17	E83704	Lock Washer M8x13x2.2 Zinc	4
18	E81874	Flat Washer M8x17x1.6 Zinc	4
19	E20346	Flat Hd Soc Machine Screw M8x25 SS	2
20	E20442	Button Hd Soc Machine Screw M5x16 Zinc	1
21	E82317	Hex Jam Nut, M5X3.5 Zinc	2
22	E83838	Screw 4.2 X 13	4
23	E82772	Hex Bolt M6x20 Zinc	2
24	E82798	Washer, 6x18x1.5	2
25	E82761	Washer 6x12x1.6	5
26	E20463	Instrument Panel ASM	1
26.1	E88293	Hour Meter	1
26.2	E20332	Panel	1
27	E20410	Electrical Control Panel ASM	1
27.1	E20374	Plate	1
27.2	E20646	Chopper Card	1
27.3	E85788	Electrical Housing	1
27.4	E20368	Resistor	1
27.5	E20104	Screw, Pan Hd Phil Self Tap M4.2x13 SS	2
27.6	E82317	Hex Jam Nut, M5X3.5 Zinc	1
27.7	E83899	Pan Hd Phil Machine Screw M5x10 SS	4
27.8	E88266	Relay Card	1
28	E88456	Electrical Cover Rubber Flap	1
29	E83796	Screw, Pan Hd Phil Self Tap M4.2x16 Zinc	3
30	E88408	Knob	1
31	E20713	Potentiometer	1

ELECTRICAL DIAGRAM

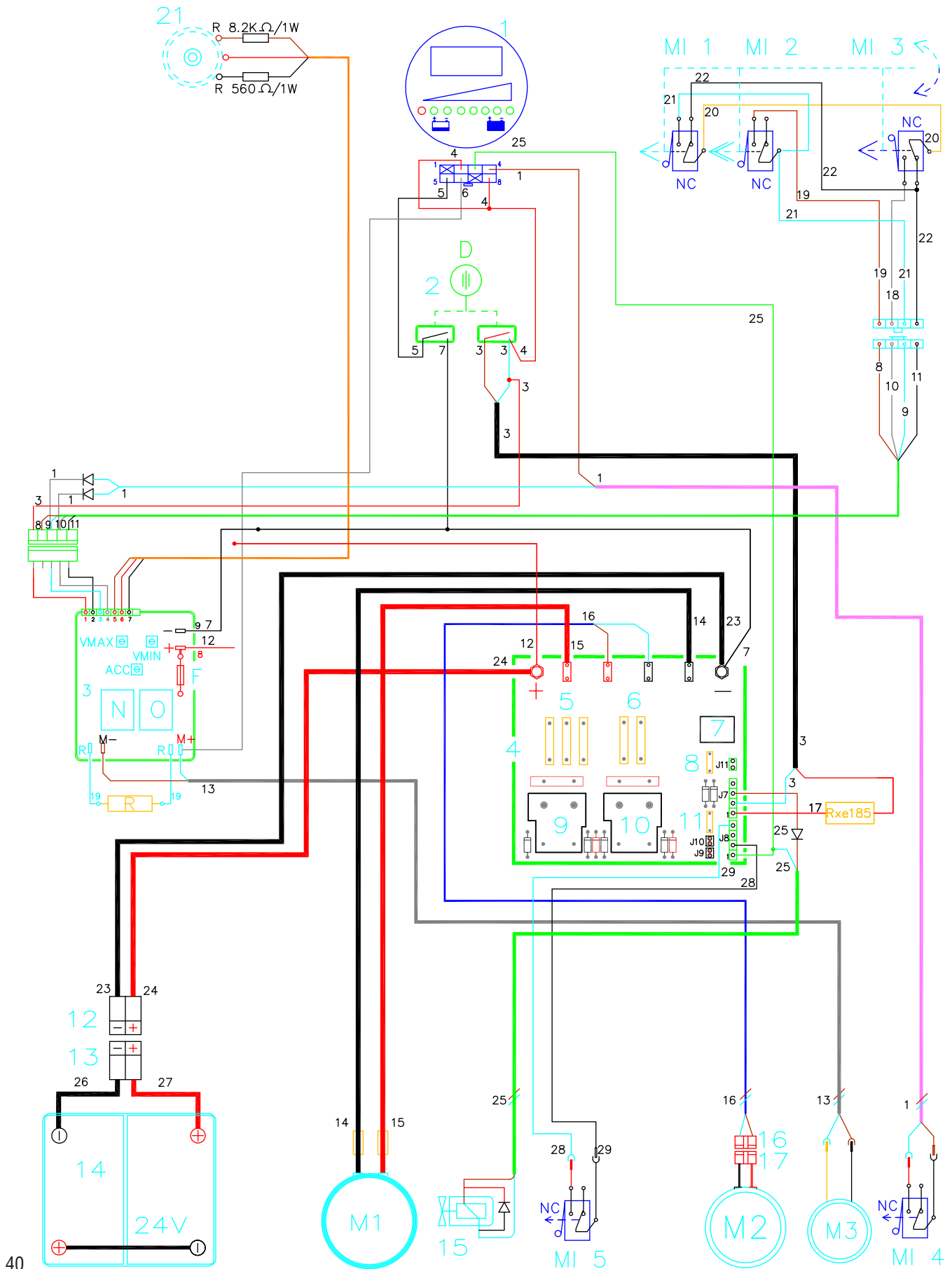

ELECTRICAL LISTING

Item#	Part #	Description	
1	E88293	Battery Check Card, Hour Meter	1
2	E82351	Key Switch Assembly w/Keys	1
3	E20646	Chopper Card	1
4	E88266	Relay Card	1
5	--	Fuse, Self Reseting Rue 800	3
6	--	Fuse, Self Reseting Rue 900	2
7	--	Relay, Vacuum Motor Auto-Hold	1
8	--	Fuse, Self Reseting Rue 90	1
9	--	Relay, Brush Motor 24V 40A	1
10	--	Relay, Vacuum Motor 24V 40A	1
11	--	Fuse, Vacuum Motor Auto-Hold Rue 90	1
12	E86208	SB50 Red Electrical Connector	2
13	E86208	SB50 Red Electrical Connector	2
14 (Std)	E11767	Battery 12V 130AH Wet	2
14 (Opt)	E88030	Battery 12V 110AH AGM	2
15	E81035	Solenoid Valve	1

Item#	Part #	Description	
16	E20402	Electrical Connector 30A	2
17	E20402	Electrical Connector 30A	2
21	E20713	Potentiometer	1
F	E83972	Fuse 30A fasten	1
N	E83159	Relay 24VDC 20A	2
O	E83159	Relay 24VDC 20A	2
R	E20368	Resistor	1
MI 1	E82270	Micro Switch	3
MI 2	E82270	Micro Switch	3
MI 3	E82270	Micro Switch	3
MI 4	E88256	Micro Switch	1
MI 5	E88279	Micro Switch Sealed	1
M1	E82576	Brush Motor 24VDC 400W	1
M2	E88291	Vacuum Motor 36VDC 550W	1
M3	E20582	Traction Motor 24VDC 150W	1

ELECTRICAL DIAGRAM

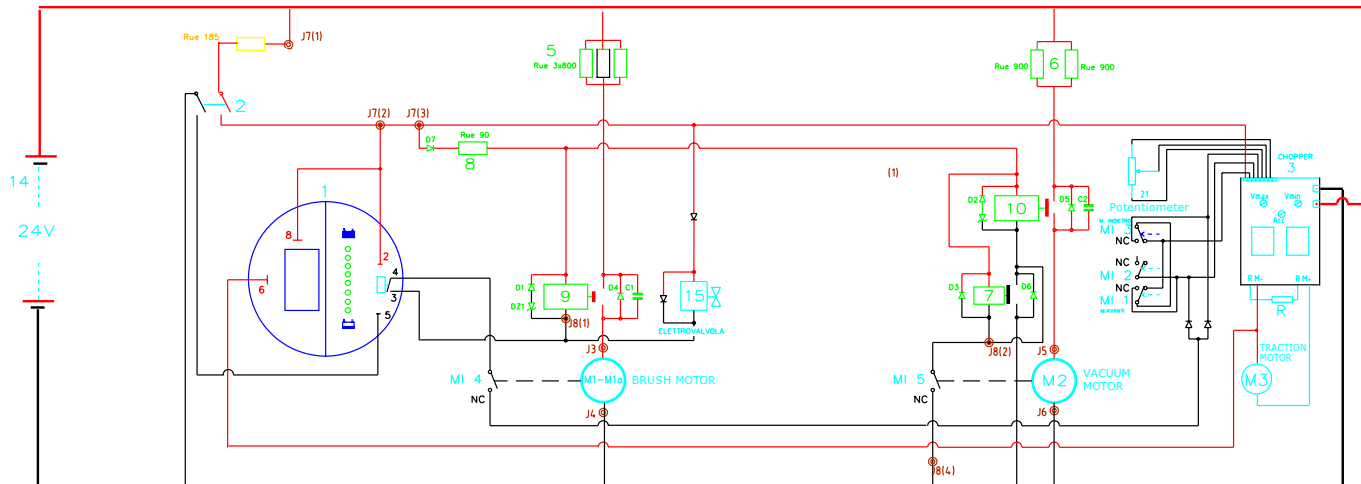

ADJUSTMENT/INSPECTIONS OF THE VARIABLE SPEED CONTROL CARD

1. Verify the functionality of the variable speed control card.
2. If necessary adjust the traction card:
 - Lift up at least one of the traction wheel .
 - Remove the handlebar for access to the electric controls.
 - Set-up the tester in volt-meter with 50V maximum.
 - Put the tester pins on the faston **M+** and **M-** of the speed control card.
 - Turn on the key master switch.
 - Pull the switch lever until you hear the forward first **micro switch click** (first speed).
 - The tester has to show a voltage between 14 and 15V. If the reading is different adjust the **trimmer** (first speed) to have the right output voltage.
 - Completely pull the switch lever until the second (maximum) speed **micro switch** is pressed. A voltage of 24V (the same as the battery voltage) has to be read; in opposite case verify the power connections and the conditions of the battery.
 - Acceleration adjustment: Adjust on the **“ACC” trimmer** to let it be between 30° and 45° respect the central position rotating clockwise. Verify that with this regulation the machine reach the maximum speed in 4 second.
 - Check the backward direction .
 - Check the braking power of the traction motor. At maximum speed the machine has to stop in about 1 meter.

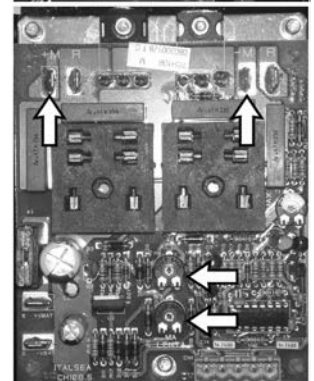
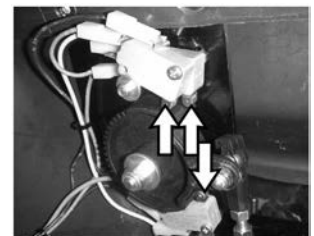

ELECTRICAL SYSTEM

1. ELECTRIC HARNESS INSPECTION

1. Verify the functionality and adjustment of the **micro switches** of the handlebar control.
2. Verify that the micro switches are pressed with the switch lever in rest position and that in that condition the micro switch lever has about **0.5 mm of movement**.
3. Verify the functionality and conditions of the **power contactors** of the **self recovery fuses** and of the connections of the control card.
4. Verify the condition of the **brake resistor** and its connection.
5. Verify the conditions of the speed control card and the functionality of the **direction contactors**.

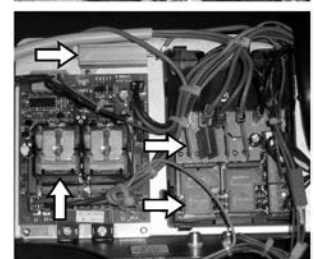
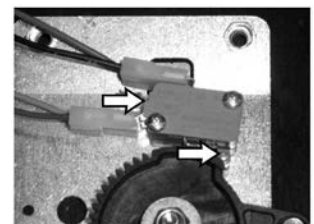

BATTERY CHECK CARD – HOUR METER

1. Verify that turning on the machine the battery check card has the following starting sequence:
 - Turning on of the LED which correspond to the set-up (red LED = “0”).
 - Turning on of all the LEDs (check of the lamps)
 - Turning on of the LEDs depending on the charge of the battery
2. Verify the hour meter functionality
 - To verify which is the set-up you simply need to turn on the machine and check which is the first LED that turns on. Counting the LEDs since the left side any LED correspond to a position and the LED which turn on correspond to the current set-up.

- Verify that if the machine uses wet cell batteries the adjustment is on position 1.

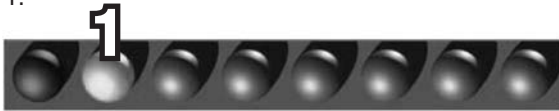

- Verify that if the machine uses GEL batteries the adjustment is on position 4.



WARNING: A wrong set-up of the battery control card can compromise the battery efficiency and damage then in irreversible way.

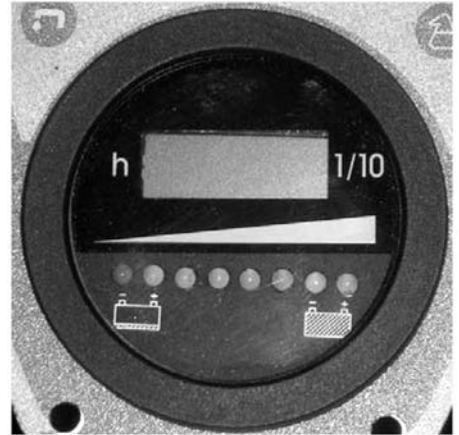

HYDRAULIC PLANT INSPECTIONS

1. Fill up the solution tank and verify the sealing of the gasket particularly on the **solution valve** and on the **drain plug**.
2. Verify that the water distribution on the floor is even and dependent on the solution valve adjustment.
3. Check the internal cleanness of the water valve. If necessary clean it using a metal bar putted inside the threaded hole of the filter plug.

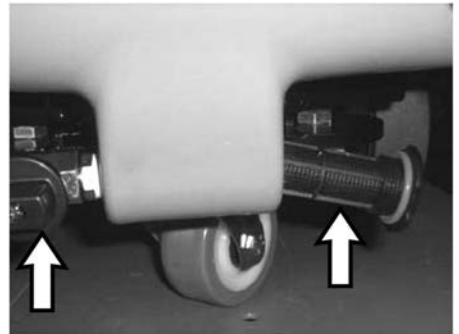

4. Verify the cleanness and functionality of the **solution filter** under the solution tank plug.



VACUUM SYSTEM INSPECTION

1. Verify the cleanness and functionality of the **float filter**.
2. Check the air sealing of the **vacuum unit** on the recovery tank.
3. Verify the connections and the sealing of the vacuum hoses and the squeegee hoses.
4. Check the sealing of the **squeegee hose adapter**.
5. Check the sealing of the exhaust hose and exhaust hose plug.
6. Vacuum micro switch adjustment:
7. Adjust the vacuum micro switch in way that when the cam on the squeegee lever **push the micro switch** there is about 0.5 mm of clearance of the micro switch lever.

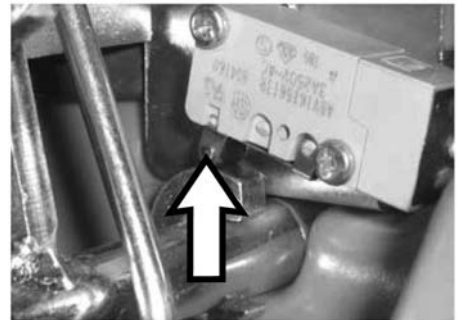
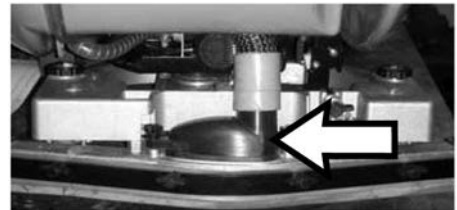
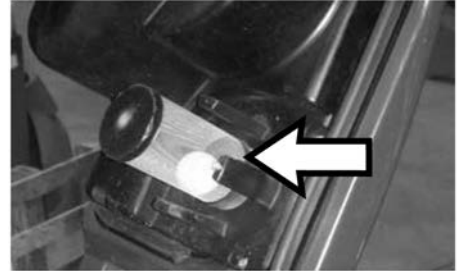

BRUSH BASE ADJUSTMENT

Verify the right inclination of the brush deck adjust. To adjust the brush deck adjust as follows:

- Lower the brush deck to the floor with a brush installed.
- **Loosen the M8 bolt and the M8 nut** that attach the brush deck to the left arm.
- **Loosen the nut and the bolt** that attach the brush deck to the idler arm.
- Verify that the brush deck correctly lays on the floor and the brush touches the floor completely.
- **Tighten the nut and its M8 bolt** to lock the left arm of the brush deck.
- Lift up the front side of the brush deck to let it be 5 mm from the floor relative to the back side.
- **Tighten the M8 nut** to secure the brush deck in position.

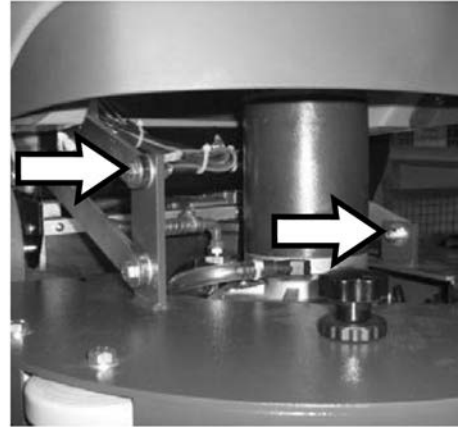

Check that the **pan head screw** on the back side is adjusted near the flat part of the brush deck. The distance between the screw head and the brush deck has to be 1 - 2 mm when the brush is locked and the brush deck is lowered.

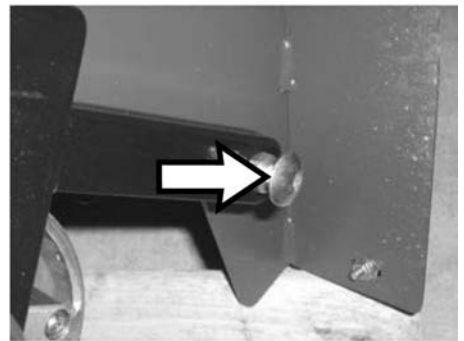

BRAKE ADJUSTMENT

1. Verify that the brake on the left hand wheel locks the wheel when active.
2. Otherwise adjust as follows:
 - Unscrew the **jam nut**.
 - Loosen the **pad screw** to achieve the right adjustment.
 - Verify the adjustment with a functional test
 - Tighten the **jam nut** to assure a right adjustment.

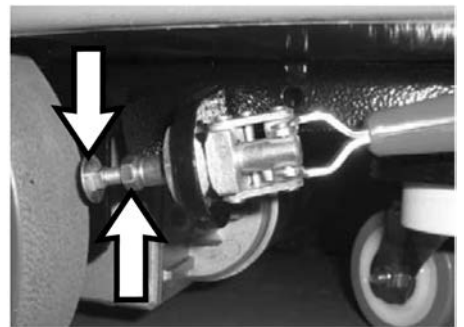

SQUEEGEE ADJUSTMENT

1. Adjust the inclination adjuster of the squeegee blade until the blade has a common inclination over its entire length.
2. Adjust the height of the wheels using the knob checking that the blade has an inclination between 30 and 45 degrees.

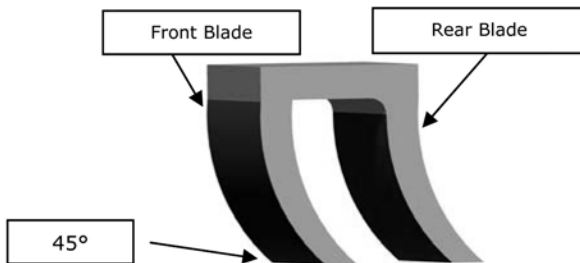

3. Verify the cleanliness and sealing of the squeegee hose adapter.

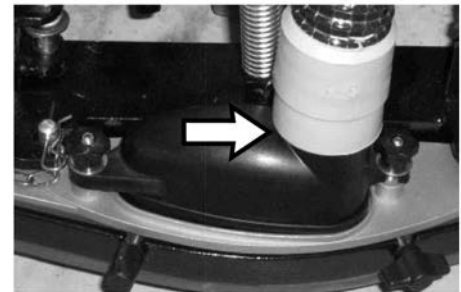
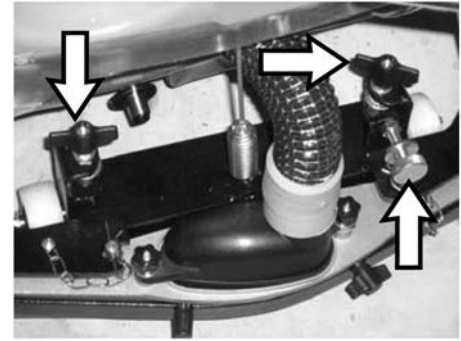

CHECK LIST

Functional check of the machine

- Check the functionality of switches.
- Check the functionality of the switch lever.
- Check the functionality of the brush deck.
- Check the functionality of the brush motor.
- Check the functionality of the solenoid valve.
- Check the functionality of the vacuum motor.
- Check the functionality of the brakes.
- Check the functionality of batteries and power cables.

Functional test of the machine

- Fill up the tanks completely and verify the sealing.
- Verify the sealing of all the water plant and that the water is dispensed through the brush.
- Adjust the inclination and the height of the squeegee blades doing a functional test.
- Adjust the inclination of the brush deck and do a functional test.
- Check the efficiency of the parking brake.
- Verify the forward and backward movement, acceleration and braking.

Final test

- Check all the functions: washing, drying and movement.

MAINTENANCE SCHEDULE							
	Stealth ASD20BT		RECOMMENDED SERVICE INTERVALS (HOURS)				
		DAILY	50	100	200	400	1,000
BATTERIES	Check water level add if necessary	DAILY					
	Check cables, connections and plugs		50				1,000
	Check cleanliness of machine battery tray				200		
ELECTRIC	Check tightness of electric contacts and fuses		50				
	Check state of electric cables crossing the machine					400	
SOLUTION TANK	Check cleanliness of solution filter	DAILY				400	
	Check water valves and hoses to the brush head		50				
	Check all water connection from the tank to the brushes				200		
RECOVERY TANK	Check cleanliness of the tank	DAILY					
	Check filter and float system	DAILY					
	Check vacuum and drain hoses	DAILY					1,000
	Check vacuum gasket and drain hoses plugs			100			
BRUSH HEAD	Check spraying guard and right brush inclination		50			400	
	Check state of bearings					400	1,000
	Check brush attachments				200		
	Check wear of rotating brushes		50		200		
BRUSH MOTOR	Check cleanliness of air cooling inlet			100			
	Check carbon brushes					400	1,000
	Check amp draw and noise level						1,000
VACUUM MOTOR	Check noise level and cleanliness of the inlet hose		50				
	Check carbon brushes				200	400	
	Check vacuum performance, replace if necessary						1,000
SQUEEGEE	Check cleanliness of the squeegee blades and shoe	DAILY					
	Check wear of rear squeegee blade		50	100			
	Check wear of front squeegee blade			100	200		
	Check squeegee structure and machine support			100			
	Check lever and lifting cable						400

Suggested replacement 

WEAR ITEMS	
PART #	DESCRIPTION
E88268	Pad Holder
E88269	Brush Poly 0.55 MM Tuft
E88271	Brush Grit Tuft
E88272	Brush Deck Splash Guard
E86169	Blade Strap
E83417	Squeegee Blade, Central Shore 33
E83987	Squeegee Blade, Central Shore 40
E83650	Squeegee Blade, Central, Oil Resistant
E11767	Battery 12V 130 AH Wet
E88030	Battery 12V 110AH AGM
E88035	Charger 24VDC 12AMP 120VAC EXT AGM WET RSB50

BETCO US WARRANTY POLICY

10 year coverage

Subject to the conditions stated below, Betco warrants parts and labor on rotationally molded polyethylene tanks/ housings and injection molded vacuum head assemblies to be free from defects in materials and workmanship for a period of ten years to the original purchaser.

3 Year Coverage

Subject to the conditions stated below, Betco warrants parts and labor on all other Betco components to be free from defects in materials and workmanship for a period of three years to the original purchaser.

1 Year Coverage

Subject to the conditions stated below, Betco offers a limited warranty on parts and labor on the following equipment: parts and accessories to be free from defects in materials and workmanship for a period of one year to the original purchaser.

- HF14 Upright Vacuum: #E88820-00
- Bac Pac Lite Vacuum: #85903-00
- FiberPRO® Floor Dryer: #85507-00
- WORKMAN™ Series Vacuums: #85024-00, #85025-00, #83012-00, #85027-00
- CV100T Vacuum: #85023-00
- All Tools and Accessories
- All Battery Chargers
- All Batteries are pro-rated for 1 year

Allowable Travel Time Warranty Reimbursement:

Eligible equipment: All battery and propane powered equipment products. Warranty period: 90 days from date of sale to the original purchaser. A maximum 180 mile round trip at 50 cents per mile will be allowed for warranty consideration.

Propane Machine Warranty:

Kawasaki engines are warranted by Kawasaki for a period of 2 years against manufacturer defects. All other components (except wear items)* are warranted by Betco for a period of 3 years.

***Wear Items exempt from Warranty consideration include but may not be limited to: power cords, transport wheels, vacuum bags, belts, squeegee blades, pad drivers, clutch plates, handle grips, filters, screens, throttle cables, brushes and carbon brushes.**

Subject to the conditions and exceptions stated in this warranty, Betco warrants the Betco products to be free from defects in material and workmanship, under normal use and service, for the periods listed under the warranty policy to the original purchaser. At any time during the warranty period, Betco will furnish replacement parts for the Betco parts to the original purchaser. Such parts will be furnished and charged including transportation costs, to the original owner through any Betco authorized Service Distributor. If the original part is returned within the warranty policy period from date of delivery for inspection by Betco and is found to be defective the owner will be credited for the cost of replacement parts plus shipping and handling. Replacement parts that have become defective through wear or abuse are not included in this warranty.

This warranty does not apply to damage or defect caused by accident, misuse, negligence, fire, or to any Betco product which has been serviced or repaired by other than an authorized Betco Service Distributor or Betco factory personnel. This warranty is void if products are used for any purpose other than that which was intended. There are no other warranties expressed or implied. In no event shall Betco be liable for incidental or consequential damages or any damage to person or property. (Please note some states do not allow the exclusion or limitations for incidental and consequential damages).

