



Electronic Service Manuals

This electronic document is provided as a service to our customers. We do not create the contents of the information contained in this document. Should you have detailed questions pertaining to the information contained in this document, you may contact Michco, or the manufacturer which provided the original information in this electronic deliverable. Michco's only part in this electronic deliverable was the electronic assembly process. By providing this manual online we are not guaranteeing parts availability.

You may contact Michco through the following methods:

Phone (517) 484-9312

2011 N. High St. -- Lansing, Michigan -- 48906

Fax: (517) 484-9836

Email: CustomerService@Michco.com

Website: www.Michco.Com

Order Parts online at:

www.Michco.Com

Directly to Parts & Service:

By Email: **CustomerService@Michco.com**

By Fax: (517) 484-9836

By Voice: (517) 484-9312

Serving the Cleaning Industry Since 1922

Notice: All copyrighted material remains property of original owners, all trademarks are property of respective owners. Manuals are subject to Manufacturer's reproduction limitations. Originals or reproductions were provided by manufacturers through a request. We make no warranty as to the correctness of information provided in this document and you assume all risk. By placing these manuals on line we are not declaring our corporation to be an manufacturer authorized dealer or provider, please check our web site for authorized manufacturers we represent.



E88778-00



GENIE™ CE HD APS

14" Cord Electric
Heavy Duty All Purpose
Automatic Scrubber



Operator and Parts
Manual

TABLE OF CONTENTS

RECEIVING THE MACHINE.....	3 - 4
GENERAL SAFETY REGULATIONS.....	5
MACHINE PREPARATION.....	6 - 8
OPERATION	9
TURNING OFF THE MACHINE	10
DAILY MAINTENANCE.....	11 - 12
TROUBLESHOOTING	14
BRUSH AND SELECTION USE.....	15
PARTS DIAGRAMS AND LISTINGS.....	16 - 30
TROUBLESHOOTING - HANDLE.....	32
TROUBLESHOOTING - WATER SYSTEM.....	32
TROUBLESHOOTING - VACUUM SYSTEM.....	33
TROUBLESHOOTING - BRUSH BASE.....	34
CHECK LIST	34
MAINTENANCE SCHEDULE AND WEAR ITEMS	35
WARRANTY	36

RECEIVING THE MACHINE

Immediately check, when receiving the machine, that all the materials indicated on delivery documents have been received and also that the machine has not been damaged in transit. If it has been damaged, this damage must be immediately reported to the shipper and also to our customer's service department. Only acting promptly in this manner will make it possible to receive missing material and to be compensated for damage.

INTRODUCTION

This is an automatic scrubber which, via the mechanical action of the rotating brush and the chemical action of a water/detergent solution, can clean any type of hard flooring. As it advances, it also collects the dirt removed and the detergent solution not absorbed by the floor.

The machine must be used only for this purpose. Even the best machines will only work well if used correctly and kept in good working order. We therefore suggest you read this instruction booklet carefully and re-read it whenever difficulties arise while using the machine. If necessary, remember that our assistance and customer service is always available for advice or direct intervention.

Serial # Plate

BETCO®		
Production Year 2011	Power Source 120 Volt AC	Power Frequency 60 Hz
Max. Op. Gradient 2%	Power Consumption 5 Amps	Machine Weight 95 lbs
Model Name GENIE CE HD APS	Part Number S/N <input type="text"/>	



SYMBOLS USED ON THE MACHINE

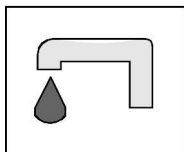

Valve symbol
Used to indicate the solenoid valve switch

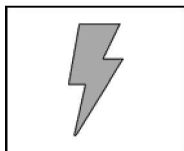

Power symbol
Used to indicate the machine's power is on

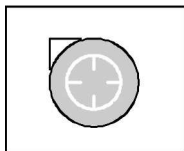

Vacuum motor symbol
Used to indicate the vacuum motor switch

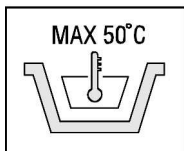

Maximum solution temperature gauge
Located near the solution tank inlet

TECHNICAL DESCRIPTION	Measurement Unit	Genie™ CE HD
Rated power	HP (W)	0.83 (570)
Working width	in (mm)	13.8 (350)
Rear squeegee width	in (mm)	17.3 (440)
Work capacity	ft ² /h (m ² /h)	11,300 (1050)
Water consumption	g/m ²	-
Brush & Pad (diameter)	in (mm)	13.8 (350)
Brush RPM	RPM	140
Brush pressure	lb (Kg)	39 (17.7)
Brush motor	V / HP (V / W)	115 / 0.50 (115 / 370)
Drive type		Pad Assist
Forward movement speed	mph (km/h)	1.9 (3)
Maximum grade		2%
Vacuum motor	V / HP (V / W)	115 / 0.33 (115 / 250)
Vacuum Motor Suction	in. of water (mbar)	29 (72)
Solution tank capacity	Gal (l)	2.0 (7.5)
Recovery tank capacity	Gal (l)	2.5 (9.3)
Weight of empty machine (including brush and tanks)	lb (Kg)	77.6 (35.2)
Weight of empty machine (without brush and recovery tank)	lb (Kg)	68.6 (31.1)
Machine dimensions open (Length / Height / Width)	in x in x in (mm/mm/mm)	24.4 x 41.3 x 17.3 (620 / 1050 / 440)
Machine dimensions closed (Length / Height / Width)	in x in x in (mm/mm/mm)	34.8 x 16.7 x 17.3 (885 / 425 / 440)

GENERAL SAFETY REGULATIONS

The regulations below must be carefully followed in order to avoid harm to the operator and damage to the machine.

- Read the labels on the machine carefully. Do not cover them for any reason and replace them immediately if they are damaged.
- The machine must be used exclusively by authorized and trained personnel.
- When operating the machine be careful of other people.
- The machine is not suitable for cleaning carpets.
- The power cable outlet must be plugged into a grounded power outlet.
- Avoid damaging the power cable by crushing, bending, cutting or stressing it.
- **WARNING:** do not let the power cable come into contact with the rotating brush.
- Whenever the power cable is damaged, immediately contact a BETCO service center.
- Do not mix different types of detergent as this may produce harmful gases.
- Do not set containers on the machine.
- Machine storage temperature is between -10°F and 130°F, never store outside under humid conditions.
- Operating conditions: room temperature between 33°F and 100°F with relative humidity between 30% to 95%.
- Do not expose the machine to rain.
- Never use the machine in an explosive environment.
- Do not use the machine as a means of transport.
- Never use acidic chemicals which could damage the machine.
- Avoid running the brushes with the machine stopped as this could damage the floor.
- Never vacuum up flammable liquids.
- Never use the machine to gather dangerous powders.
- Use a powder fire extinguisher in case of fire. Do not use water.
- Do not hit against shelving or scaffolding. The operator must always be equipped with the appropriate safety device (gloves, shoes, helmet, glasses, etc.)
- Do not use the machine on surfaces with an inclination greater than the one shown on the serial plate.
- The machine is designed to wash and dry floors simultaneously. Signal the presence of wet floors with suitable signs.
- If the machine does not work properly, perform routine maintenance. Otherwise, request the assistance of BETCO technical support.
- When replacing parts ask for ORIGINAL spare parts from your Authorized BETCO Dealer and/or Retailer.
- Always turn off the machine and unplug the power cord whenever maintenance is performed.
- Never remove guards that require tools to remove.
- **Never wash the machine with direct or pressurized jets of water or with corrosive substances.**
- Have your BETCO service center check the machine once a year.
- To prevent the formation of scale in the solution tank filter, do not store the machine with detergent in the tanks.
- Before using the machine make sure that all doors and covers are positioned as shown in this operating and maintenance manual.
- When your BETCO machine is ready to be retired, the machine must be disposed of properly. It contains oils and electronic components. The machine itself was built using totally recyclable materials.
- Use only brushes furnished with the machine or those specified in the user's manual. Use of other brushes can compromise safety.
- This machine must be operated by trained professionals.

MACHINE PREPARATION

1. HANDLING THE PACKED MACHINE

No more than two boxes can be stacked.

Total weight is 150 lb (70 kg).

Overall dimensions are:

A : 19.7 in (500 mm)

B : 19.7 in (500 mm)

C : 45.3 in (1150 mm)

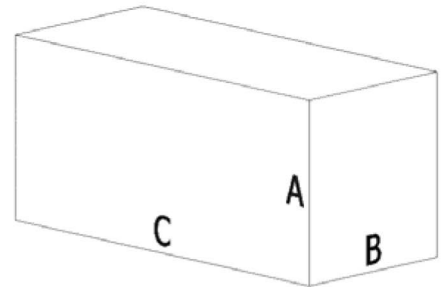

2. HOW TO UNPACK THE MACHINE

A. Open the packing on the side indicated.

B. Remove the machine from the packing.

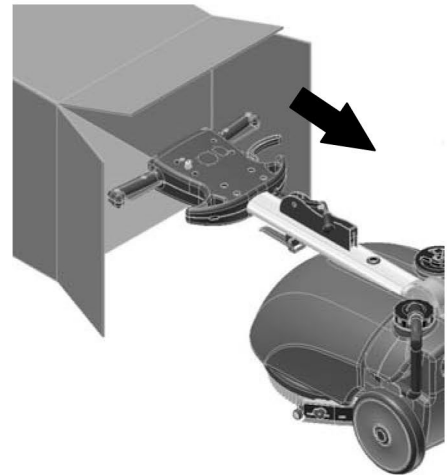

3. HANDLING AND TRANSPORTATION OF THE UNPACKED MACHINE

Genie™ CE is a machine that can be transported with little effort. Be sure that squeegee assembly is in the UP position before transport.

Lift the front end of the machine, using the machine handle as a lever. The rear wheels allow it to be transported and can be loaded on a truck with the use of an approved ramp.

Genie™ CE is easy to transport. The handle can be folded down to minimize its size.

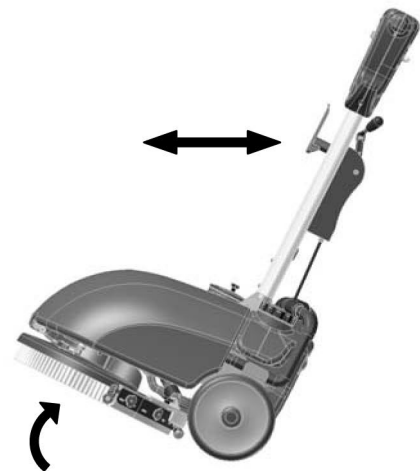

MACHINE PREPARATION

4. SUPPLY POWER FOR THE MACHINE

The machine is supplied with a 50 foot (15.2 m) power cord.

To power the machine, you must:

- A. Plug the power cord into a grounded wall outlet.



WARNING: Before plugging in the power cord, place all control switches in the off ("0") position!



5. HANDLE

The machine is shipped with the handle folded down and must be rotated to an upright operating position prior to machine use. To raise the handle:

- A. Pull the indicated lever upwards.
- B. Swing the handle to the upright working position.



6. SOLUTION TANK FILLING

Fill the solution tank with clean water at a temperature that does not exceed 120°F (50°C). Add liquid detergent at the concentration and according to the procedures recommended by the chemical manufacturer. To prevent excess foam, use a defoaming chemical in the recovery tank. If foam passes through the vacuum motor, damage will occur and will not be covered under warranty.



WARNING: Always use low-foam detergent. Add defoaming chemical to the recovery tank before starting work to prevent foam from being generated.

WARNING: Never use acids.

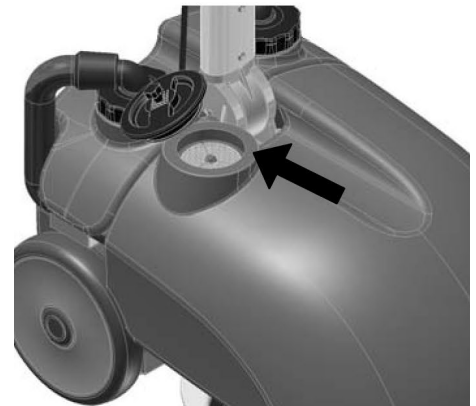

MACHINE PREPARATION

7. RECOVERY TANK

- A. Make sure that the recovery tank is properly mounted and that the hoses are properly installed onto the fittings that exit the recovery tank caps.
- B. Check that the caps are properly sealed.



8. SOLUTION TANK

- A. Check that the cap is properly connected, and that the vent pin is pushed in (A).
- B. Check that the quick connect fitting is properly connected (B).

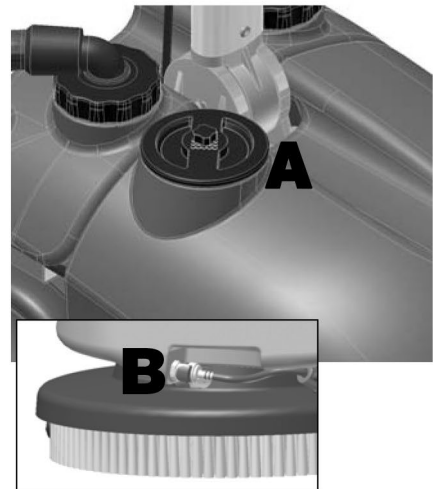

OPERATION

1. MACHINE OPERATION

Before operating the machine:

- A. Ensure all switches are in the off ("0") position.
- B. Plug the power cord into a grounded wall outlet.



- C. Lower the squeegee control lever.

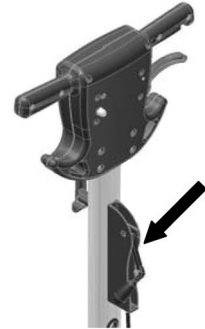

- D. Turn on main switch (1) and verify that the green indicator light comes on.
- E. Turn on the vacuum switch (2).
- F. Turn on the solenoid valve switch (3).
- G. At this point the machine is ready for operation. The operating lever will turn on the brush motor (4).



2. OVERFLOW DEVICE

The machine has a float in the filter basket that stops vacuum airflow when the recovery tank is full. When this happens the recovery tank must be emptied.



WARNING: Always wear gloves when doing this operation to protect yourself from contact with hazardous chemicals.



3. FORWARD MOVEMENT

Forward movement of the machine is assisted by the brush.



WARNING: Always make sure the squeegee is lifted when moving backwards, even for short distances.



TURNING OFF THE MACHINE

To properly turn off the machine after use or before maintenance:

1. Turn off the solenoid valve switch. **(3)**
2. Raise the squeegee with the squeegee lift lever.
3. Turn off the vacuum switch. **(2)**
4. Turn off the main switch. **(1)**
5. Unplug the power cord from the grounded wall outlet.



6. Remove the recovery tank by lifting the rubber latch on top of the recovery tank and pull the tank rearward.



7. Remove the recovery tank caps to empty the tank.
8. Remove the brush and rinse it with clear water.



WARNING: Always wear gloves to protect yourself from contact with hazardous chemicals.

DAILY MAINTENANCE



WARNING: Always wear gloves to protect yourself from contact with hazardous chemicals.

1. CLEANING THE RECOVERY TANK

- A. Disconnect the vacuum hoses.
- B. Remove the tank from the machine.
- C. Remove the caps to open the tank.
- D. Clean the filter with clear water.
- E. Rinse out the tank with clear water.



WARNING: Always wear gloves to protect yourself from contact with hazardous chemicals.

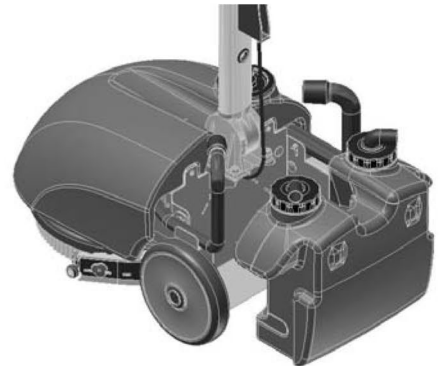

2. CLEANING THE SQUEEGEE

Verify that the squeegee blades are clean and free from cuts. This ensures optimum drying.

To clean the squeegee:

- A. Raise the front of the machine.
- B. Carefully clean the inside of the squeegee shoe.
- C. Carefully clean the squeegee blades.



WARNING: Always wear gloves to protect yourself from contact with hazardous chemicals.



DAILY MAINTENANCE

3. REPLACING THE SQUEEGEE BLADES

Examine the condition of the squeegee blades. Replace as necessary. To replace the blades:

- A. Lift the squeegee.
- B. Remove the two knobs.
- C. Detach the squeegee from the squeegee yoke.
- D. Remove the hose from the squeegee hose adaptor.
- E. Unscrew the squeegee knobs that hold the band clamps on squeegee shoe.
- F. Remove the band clamps and squeegee blades.
- G. Replace the squeegee blades and band clamps.
- H. Reinstall everything by performing this procedures in reverse.

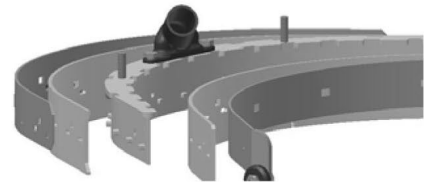
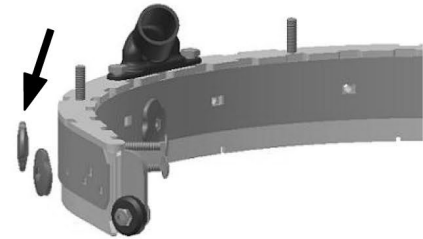
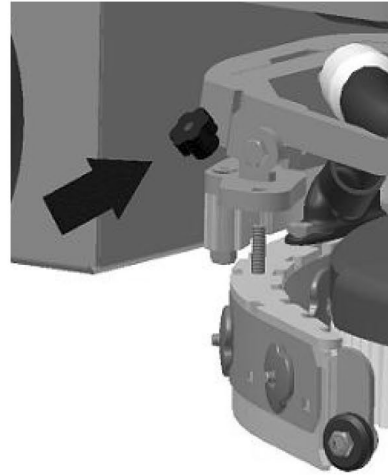

4. BRUSH DISASSEMBLY

- A. Lift the squeegee.
- B. Lift the front of the machine by pressing down on the handle until the brush is 2" - 4" off the floor.
- C. When the brush is lifted jog the brush motor. The brush releases automatically and falls onto the floor.



WARNING: Carry out all maintenance operations with the power cord unplugged from the wall outlet.

WARNING: Make sure there are no objects or people in the vicinity of the machine during brush removal.



SCHEDULED MAINTENANCE

1. CLEANING THE SQUEEGEE HOSE

Check the squeegee hose for blockage if the suction is insufficient and at periodic intervals. To clean the hose:

- A. Remove the hose end from the squeegee hose adapter.
- B. Remove the other end of the hose from the recovery tank.
- C. Wash the inside of the hose with clear water, spraying from the end that connects to the tank.
- D. Reinstall the hose.

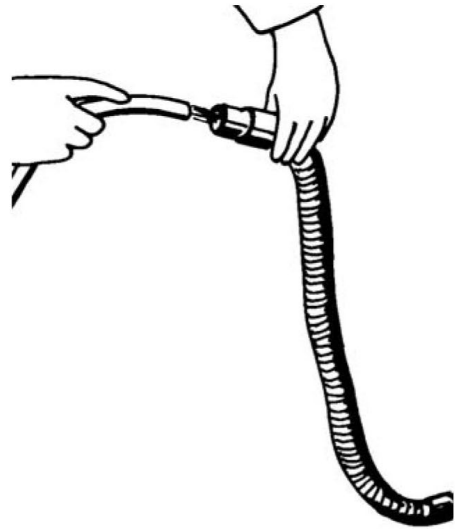

WARNING: Do not wash the hose that goes from the vacuum unit to the recovery tank. This will damage the vacuum motor!

2. CLEANING THE SOLUTION TANK AND SCREEN

- A. Unscrew the cap on the solution tank.
- B. Remove and clean the filter screen.
- C. Unplug the solution quick disconnect at the front of the tank.
- D. Using a screwdriver, remove the two screws holding the solution tank to the frame.
- E. Remove the solution tank by pushing it forwards and unhooking it from the locking plate.
- F. Rinse the tank with clear water.
- G. Drain the tank.
- H. Reinstall tank on the machine.
- I. Reinstall the filter screen and the cap.

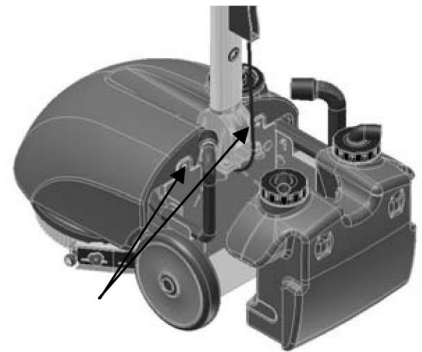

WARNING: Always wear gloves to protect yourself from contact with hazardous chemicals.

WARNING: Disconnect the quick disconnect fitting before removing the solution tank.

TROUBLESHOOTING GUIDE

1. ELECTRICAL SYSTEM SAFETY

The machine is equipped with a thermal breaker unit that has a manual reset. The brushes motor is re-enabled by resetting the thermal breaker unit located within the handle.

If the machine stops repeatedly contact the BETCO technical assistance center at 877-856-5954.

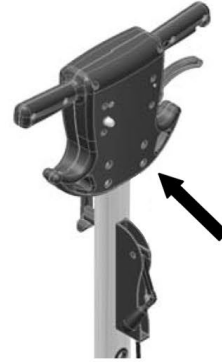

2. INSUFFICIENT WATER ON THE FLOOR

- A. Verify that the solution tank is clean.
- B. Verify that the solenoid valve switch is turned on.
- C. Verify the quick disconnect is properly connected.
- D. Verify the adjustment of the ball valve that supplies water.
- E. Verify the vent pin on the solution tank cap is lowered.

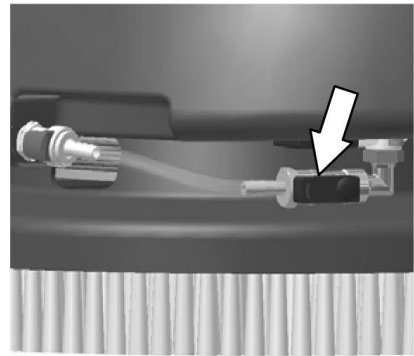

3. THE MACHINE DOES NOT CLEAN WELL

- A. Check the condition of the brushes or pad. Replace them as required.
Brushes must be replaced when the tufts are roughly 5/8" (15 mm) long.

4. THE SQUEEGEE DOES NOT DRY THE FLOOR

- A. Verify that the squeegee blades are clean.
- B. Verify that the vacuum hoses are properly installed and seated on the squeegee.
- C. Verify the vacuum hose nozzle is clean.
- D. Replace worn squeegee blades.

5. EXCESSIVE FOAM PRODUCTION

Verify that low-foam detergent is being used. Add defoaming chemical to the recovery tank.

More foam is generated when the floors are not very dirty. Dilute the detergent more when cleaning floors that are not very dirty.



BRUSH SELECTION AND USE

POLYPROPYLENE BRUSHES (PPL)

These are used on all types of floors and offer good wear resistance.

PAD DRIVERS

Pad driver and an floor pad is recommended when cleaning smooth floors.

There are two types of pad drivers:

1. The traditional pad driver is fitted with a series of anchor points that allow the abrasive floor pad to be held while working.
2. The CENTER LOCK type pad driver not only has anchor points, but also a snap-type central locking system made of plastic that allows the abrasive floor pad to be centered and held with reduced risk of it becoming detached.

BRUSH DECK PARTS DIAGRAM

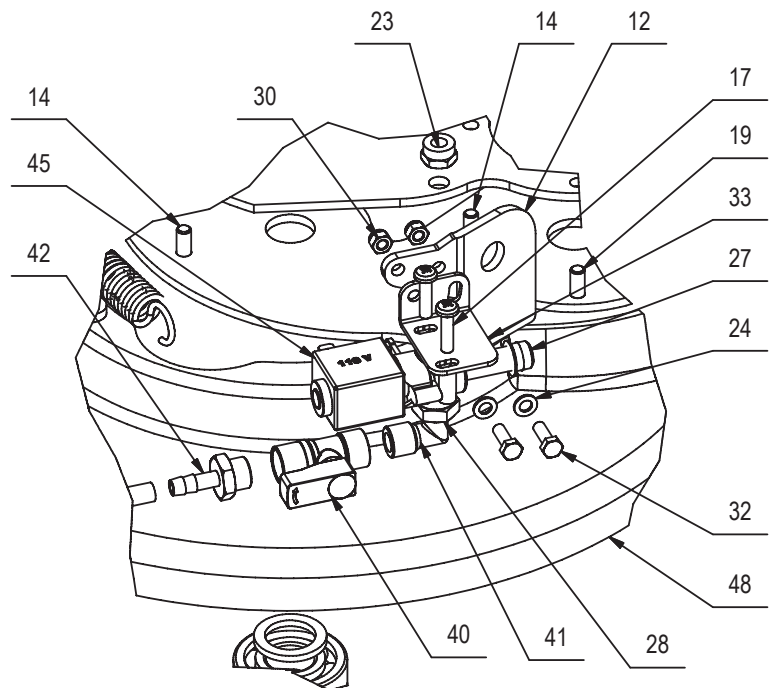
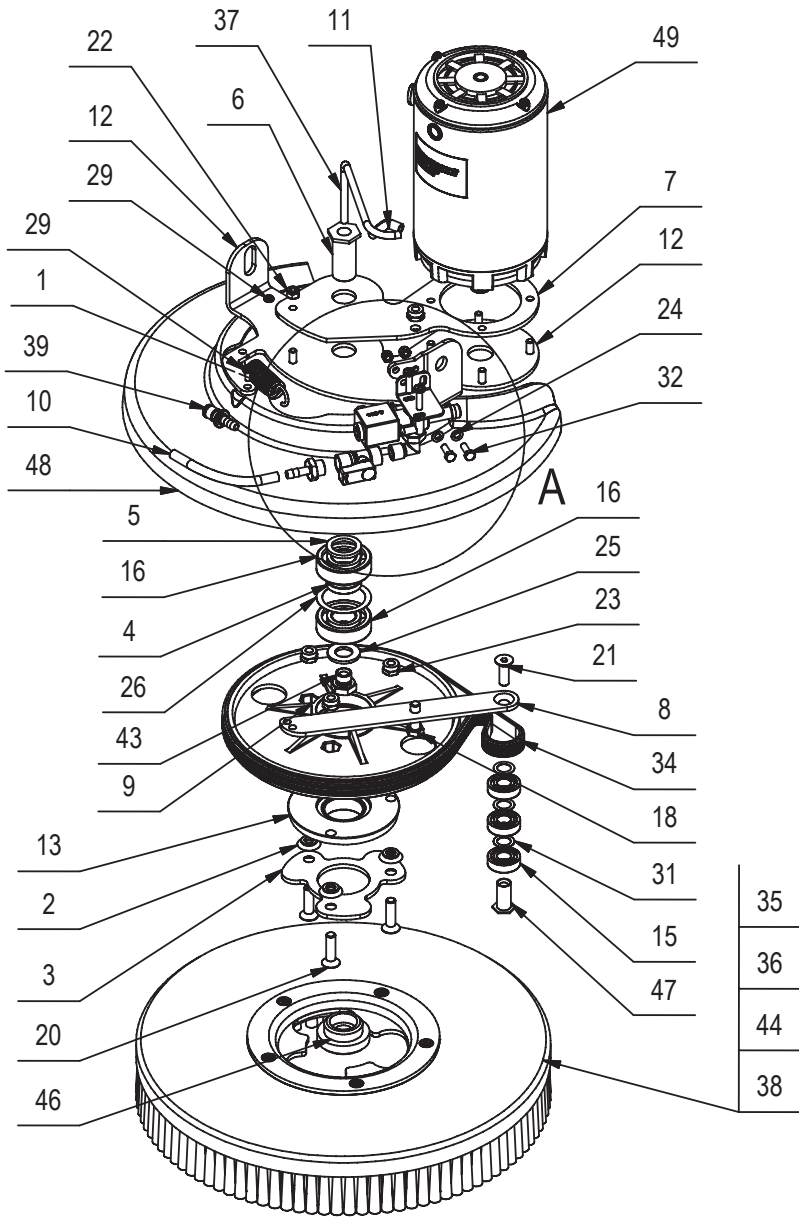

BRUSH DECK PARTS LISTING

Item#	Part #	Description	Qty.
1	E81530	Spring, 17, 5x2, 5x69 mm	1
2	E82845	Spacer	3
3	E82844	Clutch Plate	1
4	E20503	Spacer	1
5	E20019	Spacer	1
6	E20026	Bearing Shaft	1
7	E20047	Motor Mount Plate	1
8	E88366	Tensioner Arm	1
9	E20553	Clutch Pulley	1
10	E82710	Hose, 8 OD x 5 ID x L 105	1
11	E81752	Tubing 5 OD x 30 L	1
12	E22000	Support, Brush Motor	1
13	E22001	Flange	1
14	E83547	M6x16 Bolt, Zinc Hex Head	4
15	E86667	Bearing, 6001 2RS	3
16	E81657	Bearing, 6204 2RS	2
17	E82288	Screw, Pan Hd Phil Self Tap	2
18	E83833	Hex Bolt M8x25 Zinc	1
19	E88042	Flat Hd Soc Machine Screw M6x16 Zinc	1
20	E22002	Screw, M8 x 30	3
21	E20291	Flat Hd Soc Machine Screw M8x25 Zinc	1
22	E83550	NyLoc Hex Nut, M6 Zinc	1
23	E86853	Nyloc Hex Nut, M8 Zinc	4
24	E83879	Flat Washer M5x11x1 Zinc	2
25	E20395	Flat Washer M14 SS	1

Item#	Part #	Description	Qty.
26	E87290	Shim M37x47x0.3	1
27	E81719	Cap	1
28	E81967	Jam Nut, 1/4" NPT Brass"	1
29	E81998	Pan Hd Phil Machine Screw M4x10 SS	3
30	E20256	Nyloc Hex Jam Nut, M5 Zinc	2
31	E22003	Spacer	3
32	E86250	Hex Bolt M5x14 Zinc	2
33	E81727	Bracket	1
34	E81541	Brush Drive Belt	1
35	E83863	Brush, General Scrub 0.3 mm PPL	1
36	E82526	Brush, Medium Scrub 0.4 mm PPL	1
37	E86167	Pipe, 1/4" x 8" Copper	1
38	E81608	Brush, Heavy Scrub 0.6 mm PPL	1
39	E82711	Quick Disconnect, Male 1/4"	1
40	E81550	Ball Valve, 1/4" NPT Double Female	1
41	E81551	Elbow, 90 degree 1/4" NPT	1
42	E81552	Fitting, Brass, 1/4" x 7mm	1
43	E20157	Hex Lug	1
44	E88140	Pad Holder 14" STD	1
45	E88303	Solenoid Valve 110V	1
46	E22004	Bushing	1
47	E22005	Bushing	1
48	E22006	Brush Cover	1
49	E22007	Motor, Brush Drive, 0.5 HP	1

SQUEEGEE SYSTEM PARTS DIAGRAM

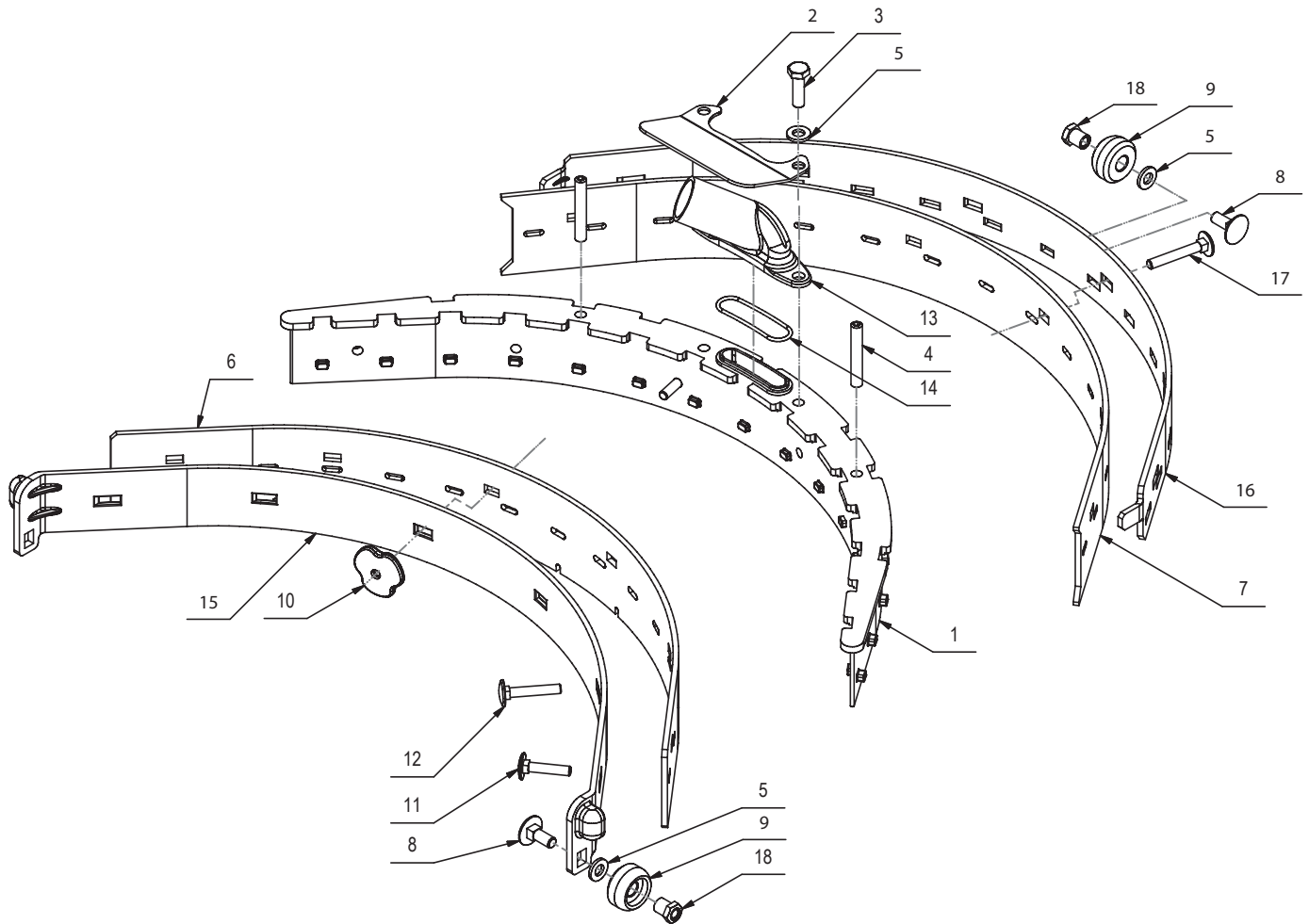

SQUEEGEE SYSTEM PARTS LISTING

Item#	Part #	Description	Qty.
1	E85792	Squeegee Shoe	1
2	E20701	Squeegee Hose Guard	1
3	E83914	Hex Bolt M6x20 SS	2
4	E82707	Set Screw Hex Soc Flat End M6x40 SS	2
5	E81934	Flat Washer M6x12x1.6 SS	5
6	E83870	Squeegee Blade, Front, Shore 33	1
7	E83869	Squeegee Blade, Rear, Shore 33	1
8	E81896	Carriage Bolt M6x16 SS	3
9	E81531	Squeegee Support Wheel 24 OD x 12.7 W	3

Item#	Part #	Description	Qty.
10	E81753	Knob M5	6
11	E86264	Carriage Bolt M5x25 SS	2
12	E81941	Carriage Bolt M5x30 SS	2
13	E81815	Squeegee Vacuum Adapter	1
14	E81755	O-Ring	1
15	E81909	Front Squeegee Band Clamp	1
16	E82731	Rear Squeegee Blade Band Clamp	1
17	E20616	Carriage Bolt M5 x 35 SS	2
18	E81897	Bushing	3

SQUEEGEE YOKE PARTS DIAGRAM

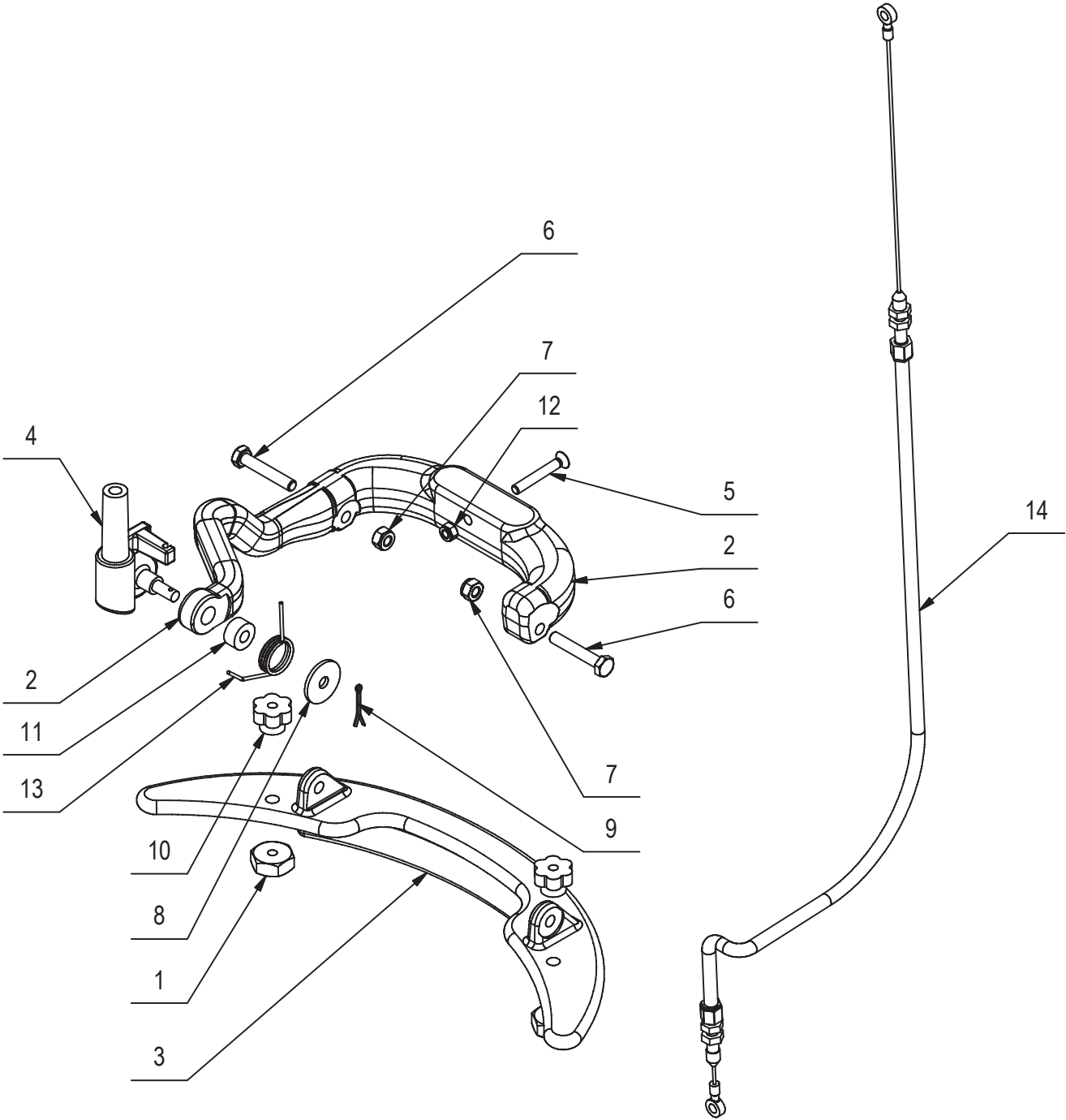

SQUEEGEE YOKE PARTS LISTING

Item#	Part #	Description	Qty.
1	E83512	Spacer	2
2	E87971	Squeegee Yoke Support Arm	1
3	E86153	Squeegee Yoke	1
4	E82839	Squeegee Yoke Pivot	1
5	E86263	Oval Hd Phil Machine Screw M5x35 SS	1
6	E83834	Hex Bolt M6x35 Zinc	2
7	E83550	NyLoc Hex Nut, M6 Zinc	2

Item#	Part #	Description	Qty.
8	E83278	Flat Washer M6.5x24x2 Zinc	1
9	E83710	Cotter Pin D2x20 Zinc	1
10	E83810	Knob	2
11	E86152	Spacer, PVC 15x6.5x7.5	1
12	E20382	Nyloc Hex Nut, M5 x 5 Zinc	1
13	E81545	Spring	1
14	E88231	Squeegee Lift Cable Genie CE	1

MAIN FRAME PARTS DIAGRAM

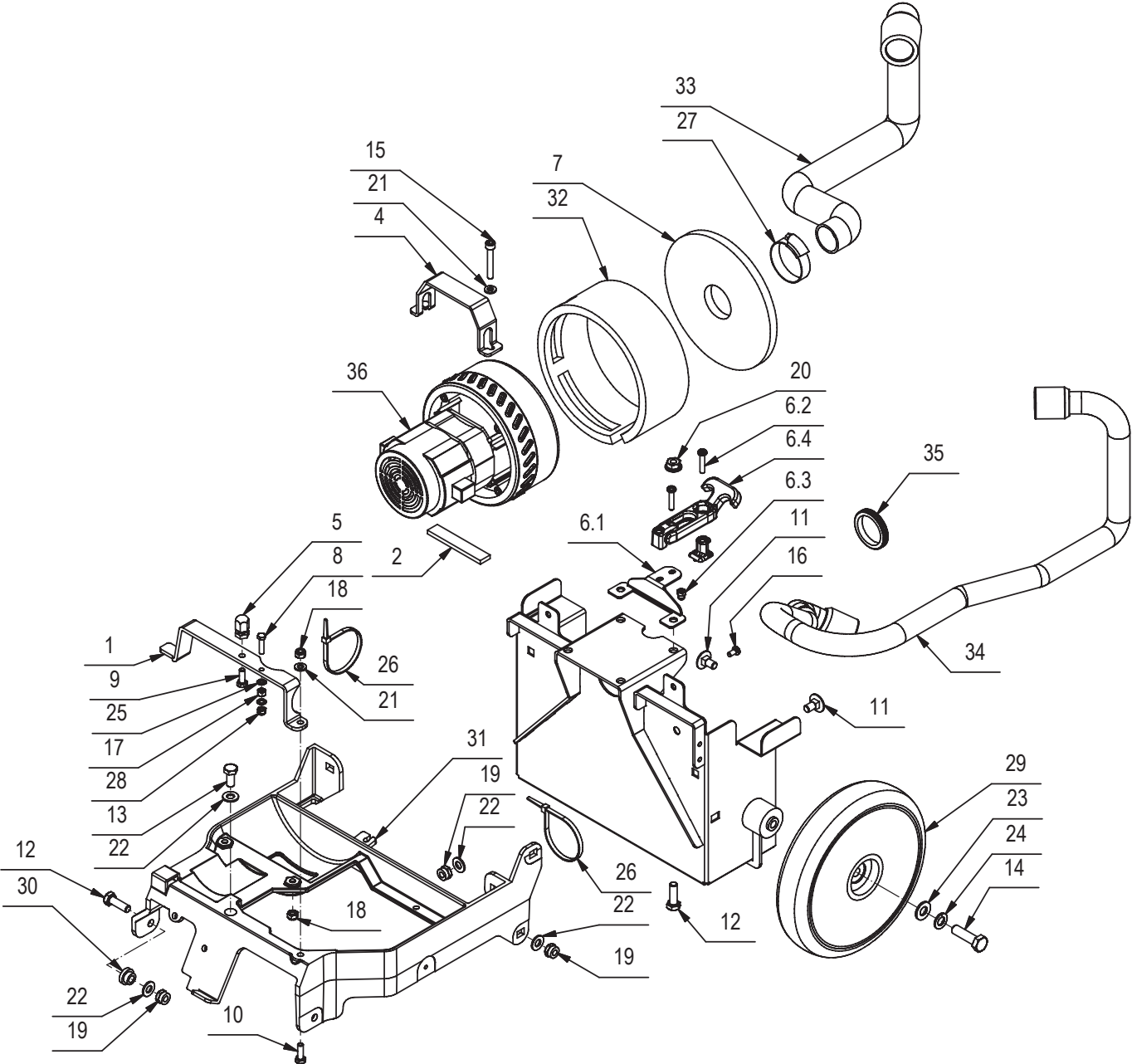

MAIN FRAME PARTS LISTING

Item#	Part #	Description	Qty.
1	E20053	Bracket	1
2	E20279	Dampener	1
3	E20604	Main Frame Weldment	1
4	E20549	Bracket Clamp	1
5	E20070	Hex Lug	1
6	E22008	Tank Hook Kit	1
6.1	E22009	Tank Hook Support	1
6.2	E22010	Screw, Pan Hd Phil M5 x 25	3
6.3	E22011	Acorn Nut, M5	2
6.4	E22012	Tank Latch	1
7	E83944	Sound Deadening Foam	1
8	E83881	Hex Bolt M5x20 Zinc	1
9	E83547	M6x16 Bolt, Zinc Hex Head	1
10	E20088	Hex Bolt M6x18 Zinc	1
11	E20235	Carriage Bolt M8x16 Zinc	4
12	E83833	Hex Bolt M8x25 Zinc	6
13	E20098	Hex Bolt M8x18 Zinc	1
14	E82455	Hex Bolt M10x35 Zinc	2
15	E20342	Soc Hd Cap Screw M6x40 Zinc	2
16	E83899	Pan Hd Phil Machine Screw M5x10 SS	2

Item#	Part #	Description	Qty.
17	E83535	Hex Nut, M5x5 Zinc	1
18	E83550	NyLoc Hex Nut, M6 Zinc	3
19	E86853	Nyloc Hex Nut, M8 Zinc	6
20	E20251	Flange Nut M8	4
21	E82761	Flat Washer M6x12x1.6 Zinc	3
22	E81874	Flat Washer M8x17x1.6 Zinc	7
23	E86255	Flat Washer M10x21x2 SS	2
24	E83948	Lock Washer M10x18x2.2 Zinc	2
25	E83841	External Serrated Lock Washer M5 Zinc	2
26	E81565	Clamp, 4.8x200 Black	3
27	E83966	Hose Clamp	1
28	E20256	Nyloc Hex Jam Nut, M5 Zinc	1
29	E81539	Transport Wheel 200 OD x 42 W	2
30	E20383	Bushing	2
31	E87024	Main Frame Weldment	1
32	E82840	Sound Deadening Foam	1
33	E20557	Hose, Vacuum 29 D x 590 L	1
34	E20270	Hose, Vacuum 20 D x 950 L	1
35	E20597	Grommet	1
36	E88302	Vacuum Motor 120VAC 250W	1

SOLUTION AND RECOVERY TANKS PARTS DIAGRAM

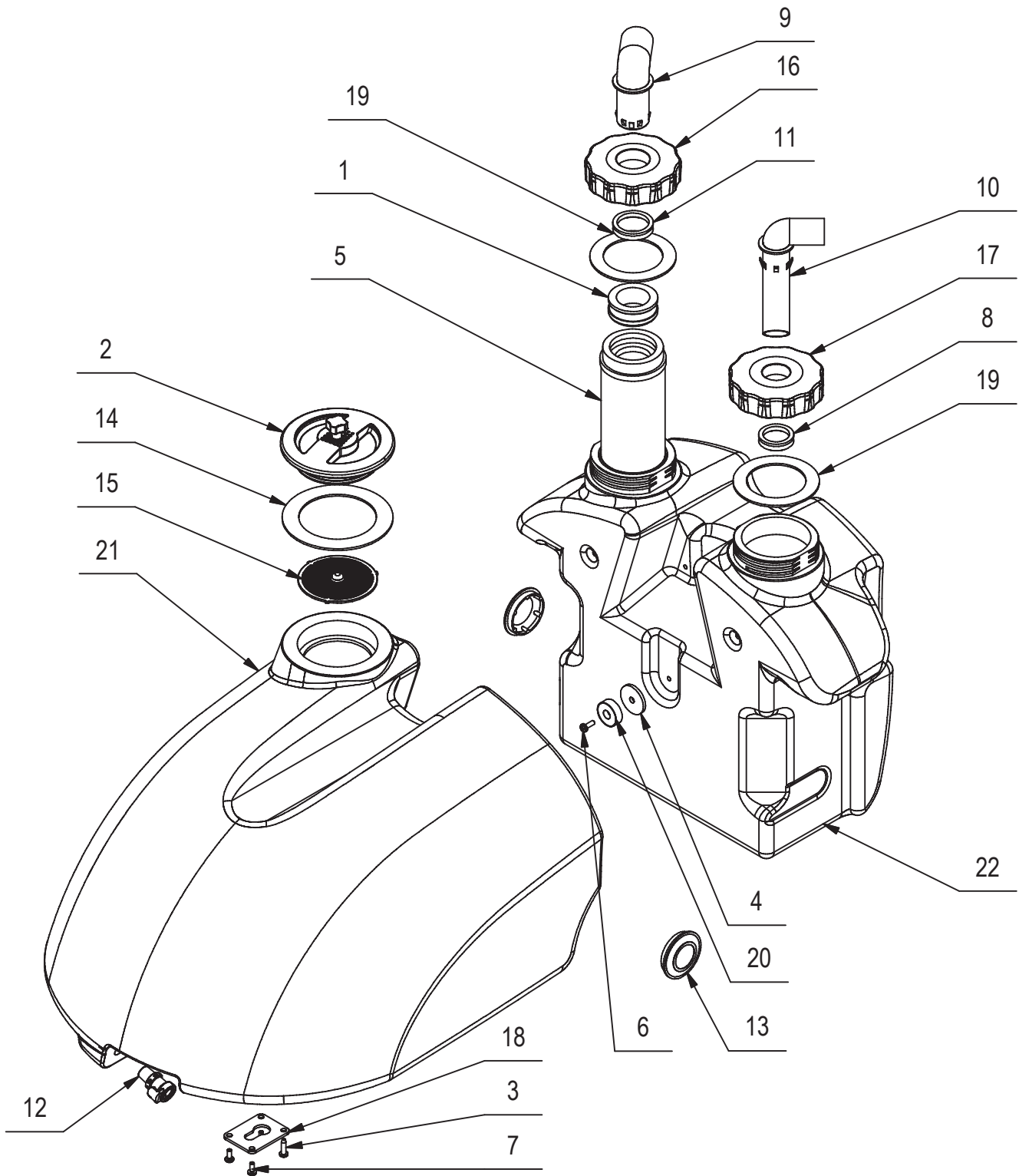

SOLUTION AND RECOVERY TANKS PARTS LISTING

Item#	Part #	Description	Qty.
1	E82853	Filter Flange	1
2	E81548	Solution Tank Cap	1
3	E20107	Screw, Pan Hd Phil Self Tap M4.2x16 SS	1
4	E83798	Flat Washer M6x30x3 PVC Black	1
5	E82790	Air Filter/Shutoff	1
6	E22013	Pan Hd Phil Screw M4x12 SS	1
7	E81998	Pan Hd Phil Machine Screw M4x10 SS	3
8	E81944	Grommet	1
9	E81849	Vacuum Elbow Fitting	1
10	E81943	Vacuum Elbow Fitting Long	1
11	E86193	Grommet	1

Item#	Part #	Description	Qty.
12	E82712	Quick Disconnect, Female 1/4	1
13	E81971	Wheel Cap	2
14	E20545	Gasket, Vispa	1
15	E88233	Filter, Inlet	1
16	E20268	Recovery Tank Vacuum Cap	1
17	E20194	Recovery Tank Inlet Cap	1
18	E20269	Latch Plate	1
19	E20327	Recovery Tank Cap Gasket	2
20	E20307	Magnet	1
21	E20490	Solution Tank, Genie CE	1
22	E20193	Recovery Tank, Genie CE	1

CONTROL HANDLE PARTS DIAGRAM

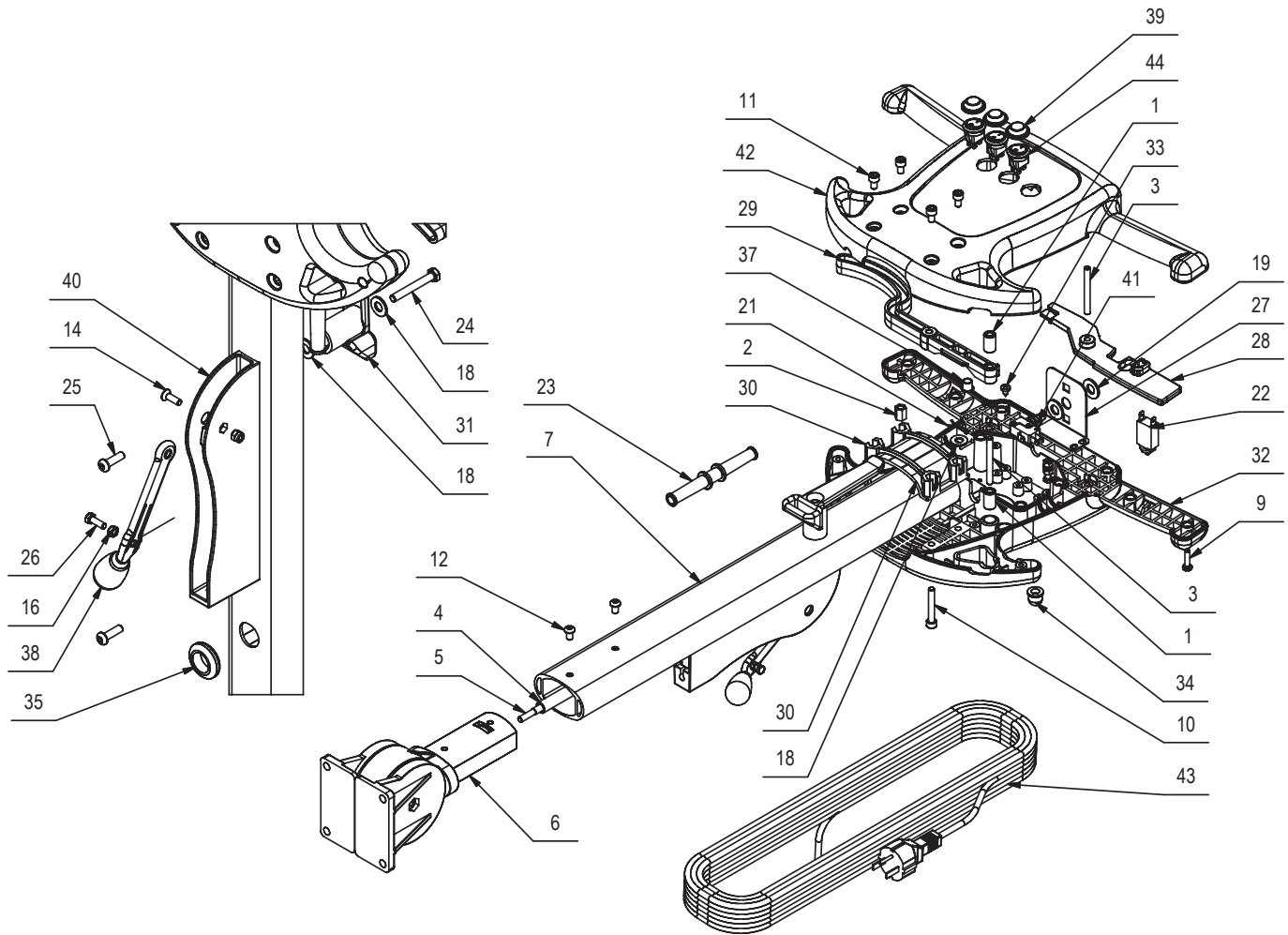

CONTROL HANDLE PARTS LISTING

Item#	Part #	Description	Qty.
1	E86149	Bushing	2
2	E85770	High Hex Nut M6x13 Zinc	4
3	E81793	Spring Pin M6x12 Zinc	3
4	E20273	Connector Tube	1
5	E82721	Tie Rod	1
6	E20593	Handle Pivot Base ASM	1
7	E20527	Handle Tube	1
8	E83881	Hex Bolt M5x20 Zinc	1
9	E82288	Screw, Pan Hd Phil Self Tap	10
10	E20342	Soc Hd Cap Screw M6x40 Zinc	4
11	E82835	Soc Hd Cap Screw M6x10 Zinc	4
12	E20319	Button Hd Soc Machine Screw M6x10 Zinc	2
13	E20109	Screw, Pan Hd Phil Self Tap M4.8x19 Zinc	1
14	E20290	Flat Hd Soc Machine Screw M5x16 SS	1
15	E83535	Hex Nut, M5x5 Zinc	2
16	E82317	Hex Jam Nut, M5X3.5 Zinc	1
17	E82256	Nyloc Hex Nut, M5x7 Zinc	1
18	E81874	Flat Washer M8x17x1.6 Zinc	3
19	E82773	Flat Washer M10x21x2 Zinc	2
20	E83841	External Serrated Lock Washer M5 Zinc	2
21	E83710	Cotter Pin D2x20 Zinc	1
22	E22014	Circuit Breaker, 6A	1

Item#	Part #	Description	Qty.
23	E22015	Cord Strain Relief	1
24	E20360	Hex Bolt M6x45 Zinc	1
25	E20364	Button Hd Soc Machine Screw M6x20 Zinc	2
26	E86250	Hex Bolt M5x14 Zinc	1
27	E20567	Bracket	1
28	E81792	Switch Lever	2
29	E81766	Lever, Handle Adjustment	1
30	E81994	Support	1
31	E20547	Power Cord Hanger	1
32	E81744	Handle Bar Console Rear	1
33	E86150	Screw, Pan Hd Phil Self Tap M4.8x9.5 SS	4
34	E88299	Cover, Thermal Switch	1
35	E20302	Grommet	1
36	E20397	Wire Clamp	1
37	E81790	Cap	1
38	E20264	Squeegee Lift Lever	1
39	E20306	Rocker Switch Cover	3
40	E20548	Bracket, Squeegee Lift Lever	1
41	E88232	Micro Switch	1
42	E22016	Handle Cover, Front	1
43	E20690	Power Cord	1
44	E22017	Switch, 2-Way Rocker	3

ELECTRIC SYSTEM PARTS DIAGRAM

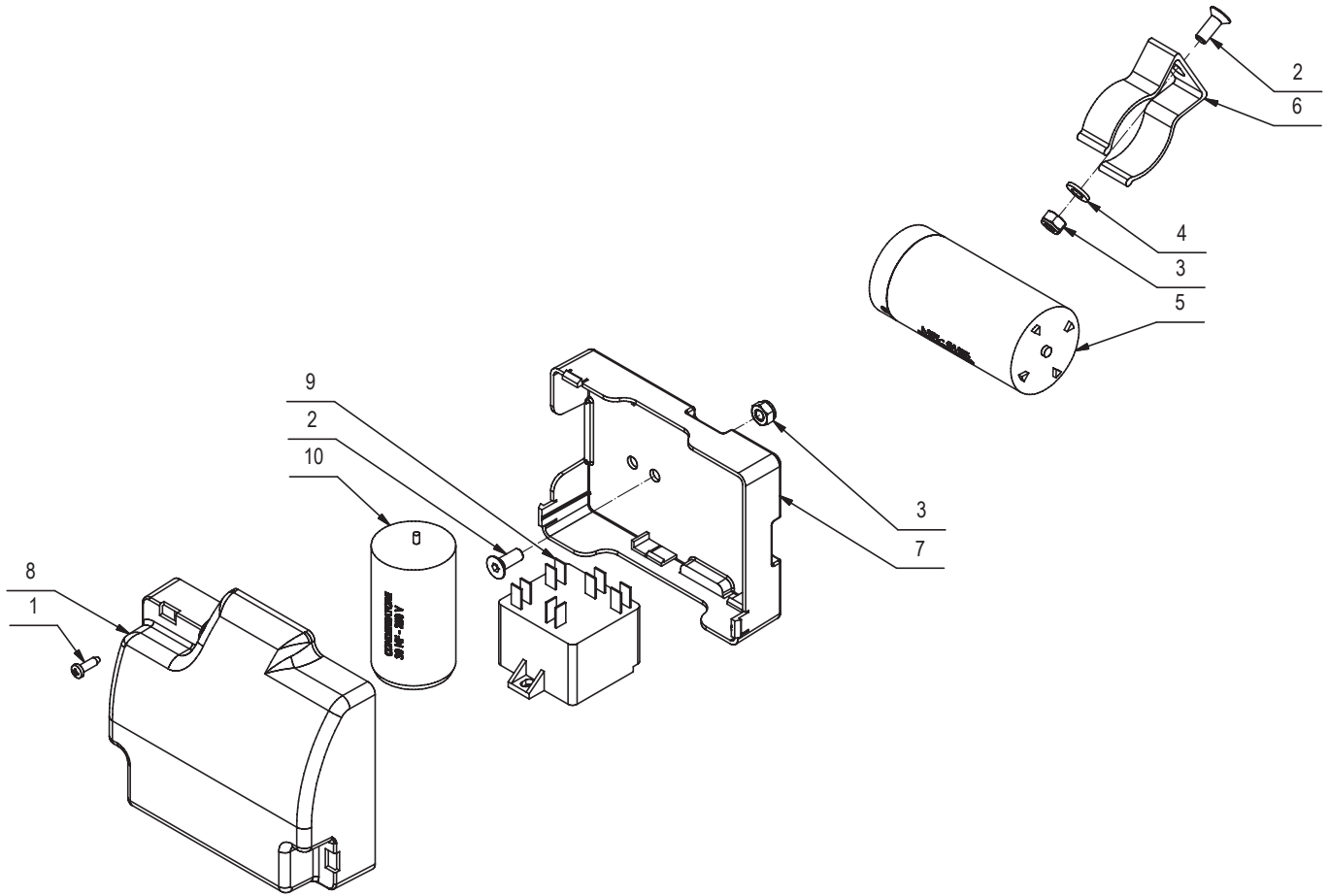

ELECTRIC SYSTEM PARTS LISTING

Item#	Part #	Description	Qty.
1	E20343	Screw, Pan Hd Phil Self Tap M3.9x13 SS	3
2	E88042	Flat Hd Soc Machine Screw M6x16 Zinc	2
3	E83550	NyLoc Hex Nut, M6 Zinc	2
4	E82761	Flat Washer M6x12x1.6 Zinc	1
5	E22018	Capacitor, Start	1

Item#	Part #	Description	Qty.
6	E81786	Hose Clip	1
7	E85788	Electrical Housing	1
8	E85771	Electrical Cover	1
9	E88308	Switch, Start / Run 110V	1
10	E22019	Capacitor, Run	1

ELECTRICAL DIAGRAM

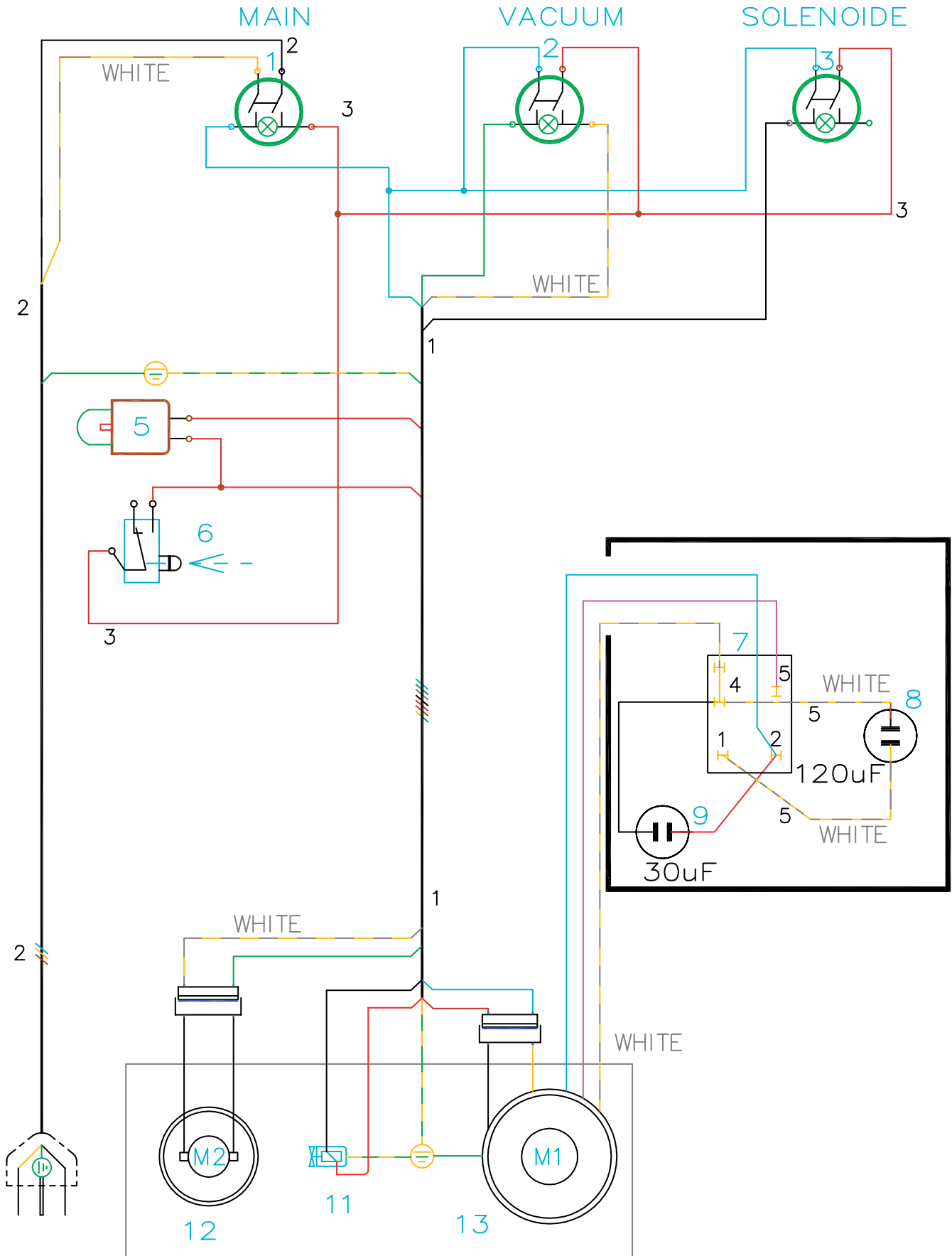

TROUBLE SHOOTING - HANDLE



Remove the plug from the outlet before any inspection. The voltage and the frequency on the machine label must correspond with the voltage and frequency of the electric power supply. The outlet has to be grounded.

1. VERIFY THE FUNCTIONS OF THE ELECTRICAL SUPPLY

- Confirm that the supply cable and the socket-plug are not damaged.
- Check the connection of the grounded power cable on the machine.

2. CHECK THE FUNCTIONALITY OF THE CONTROL PANEL

- Brush motor (the motor starts only when the **brush switch (A)** and the **switch levers** are actuated).
- Vacuum motor (turn it on **switch (C)**).
- Solenoid valve (this is turned on only when the **solenoid valve switch (D)** and **switch levers (B)** are actuated).

3. CHECK THE FUNCTIONALITY OF THE HANDLE ADJUSTER

If necessary, adjust it as follow:

- Unscrew the 4 screws which attach the handle support.
- Be sure that the **M6x10 screw** is loose and that the pin can move.
- Check between the pin and the inside face of the rod that there are **2 to 3 threads**.

4. VERIFY CLEARANCE BETWEEN THE TIE ROD AND THE LOCKING BOLT

- If necessary unscrew the **M8 nut** until there is clearance.
- If the handle bar doesn't lock, adjust the lock nut.

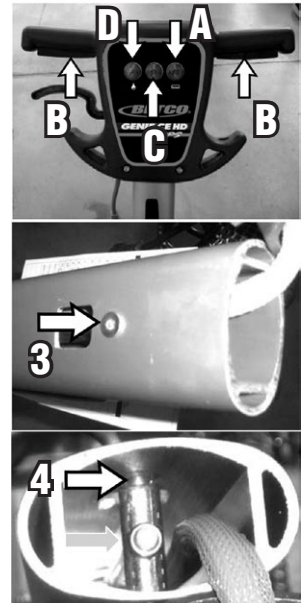

TROUBLE SHOOTING - WATER SYSTEM

1. CHECK THE FUNCTIONALITY AND THE CLEANLINESS OF THE SOLUTION FILTER.

2. CHECK THE FUNCTIONALITY OF THE CLEAN WATER CAP AND THE FUNCTIONALITY OF THE AIR VENT.

3. FILL THE SOLUTION TANK AND CHECK FOR FOR WATER LEAKS AT THE BALL VALVE AND SOLENOID VALVE.

4. CHECK THAT THE WATER FLOW TO THE FLOOR IS UNIFORM AND PROPORTIONAL TO THE VALVE SETTING.

5. CHECK THE QUICK CONNECT COUPLING CONNECTION.

6. CHECK THE CLEANLINESS OF THE COMPLETE WATER SYSTEM AND THE DISPENSING TUBE AT THE CENTER OF THE BRUSH CLUTCH.

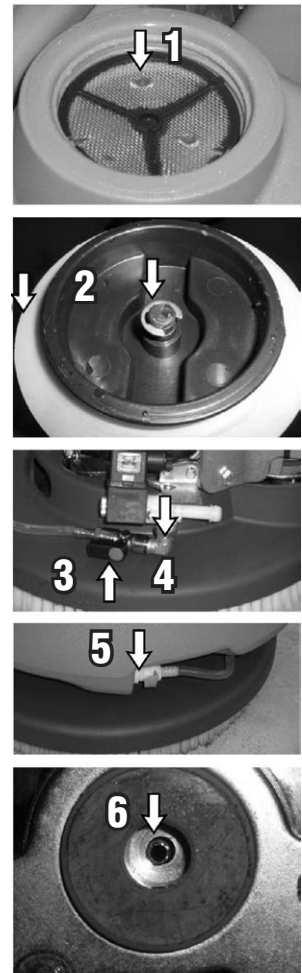

TROUBLE SHOOTING - VACUUM SYSTEM

1. CHECK THE CLEANLINESS AND FUNCTIONALITY OF THE FILTER AND FLOATS.



2. CONFIRM CORRECT POSITIONING AND THE FUNCTIONALITY OF THE HOSES ON THE CAPS OF THE RECOVERY TANK.

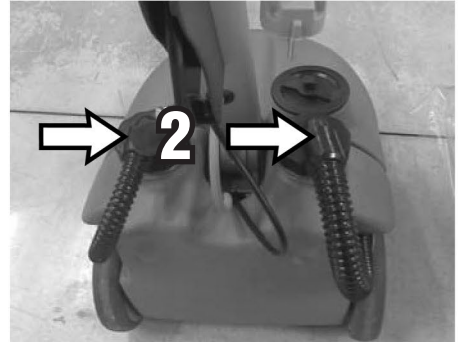

3. CHECK THE WEAR OF THE SQUEEGEE BLADE AND THAT THE ATTACHMENT KNOBS ARE TIGHT.
4. CHECK THE TIGHTNESS OF THE KNOBS ON THE SQUEEGEE BLADE BAND CLAMP.

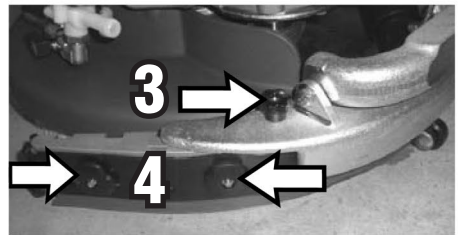

5. TO ENSURE CORRECT USE OF SQUEEGEE, VERIFY FREE MOVEMENT OF SQUEEGEE SUPPORT.



TROUBLE SHOOTING - BRUSH BASE

1. CHECK THAT THE BRUSH BASE SUPPORT ON THE RIGHT SIDE IS FREE TO MOVE INSIDE THE HOLE OF THE FRAME ARM.

- This allows the brush base to adjust itself to the floor. If movement is restricted, slightly loosen lock nut.

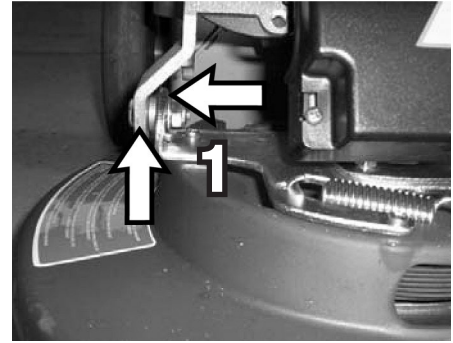

CHECK LIST

Functional check

- Check the switches and lights functionality.
- Check the brush base functionality.
- Check the brush motor functionality.
- Check the squeegee functionality.
- Check the vacuum motor functionality.
- Check the condition of the electrical plug and the cables.

Functional test

- Fill solution and recovery tanks to check for leaks.
- Check the wear of the squeegee blades.
- Check the functionality of water ball valve and solenoid valve.

Final test

- Check all functions: cleaning, drying.

MAINTENANCE SCHEDULE								
Genie CE HD		RECOMMENDED SERVICE INTERVALS (HOURS)						
		DAILY	50	100	250	400	750	1,000
ELECTRIC	Check tightness of electric contacts and fuses			100				1,000
	Check state of electric cables crossing the machine					400		
SOLUTION TANK	Check cleanliness of solution filter	DAILY					750	
	Check water valves and hoses to the brush head			100			750	
	Check all water connection from the tank to the brushes				250			
RECOVERY TANK	Check cleanliness of the tank	DAILY						
	Check filter and float system	DAILY					750	
	Check vacuum and drain hoses	DAILY						1,000
	Check vacuum gasket and drain hoses plugs			100				
BRUSH HEAD	Check splash guard and right brush inclination			100				
	Check tightness and of the belts and state of bearings				250			1,000
	Check brush attachments (rust, ruined parts, cracks)				250			
	Check wear of the brushes		50		250			
BRUSH MOTOR	Check cleanliness of air cooling inlet			100				
	Check carbon brushes				250	400		
	Check Amps consumption and noise level							1,000
VACUUM MOTOR	Check noise level and cleanliness of the inlet hose			100				
	Check carbon brushes				250		750	
	Check vacuum performance, replace if necessary					400		1,000
SQUEEGEE	Check cleanliness of the blades and squeegee regulation	DAILY						
	Check wear of back blade		50	100				
	Check wear of front blade			100	250			
	Check squeegee structure and machine support					400		
	Check lever and lifting cable					400		

Suggested replacement 

WEAR ITEMS	
Genie CE HD	
PART NUMBER	DESCRIPTION
E81608	Aggressive Brush
E82408	Pad Holder
E82526	Brush, Med. Scrubbing
E83863	Brush, General Scrubbing
E83869	Squeegee Blade, Rear, Shore 33
E83870	Squeegee Blade, Front, Shore 33

BETCO US WARRANTY POLICY

10 year coverage

Subject to the conditions stated below, Betco warrants parts and labor on rotationally molded polyethylene tanks/housings and injection molded vacuum head assemblies to be free from defects in materials and workmanship for a period of ten years to the original purchaser.

3 Year Coverage

Subject to the conditions stated below, Betco warrants parts and labor on all other Betco components to be free from defects in materials and workmanship for a period of three years to the original purchaser.

1 Year Coverage

Subject to the conditions stated below, Betco offers a limited warranty on parts and labor on the following equipment: parts and accessories to be free from defects in materials and workmanship for a period of one year to the original purchaser.

- PowerUp™ 14 Upright Vacuum: #E29990-00
- Bac Pac Lite Vacuum: #85903-00
- FiberPRO® Floor Dryer: #85507-00
- WORKMAN™ Series Vacuums: #85024-00, #85025-00, #83012-00, #85027-00
- All Tools and Accessories
- All Battery Chargers
- All Batteries are pro-rated for 1 year

Allowable Travel Time Warranty Reimbursement:

Eligible equipment: All battery and propane powered equipment products. Warranty period: 90 days from date of sale to the original purchaser. A maximum 180 mile round trip at 50 cents per mile will be allowed for warranty consideration.

Propane Machine Warranty:

Kawasaki engines are warranted by Kawasaki for a period of 2 years against manufacturer defects. All other components (except wear items)* are warranted by Betco for a period of 3 years.

***Wear Items exempt from Warranty consideration include but may not be limited to: power cords, transport wheels, vacuum bags, belts, squeegee blades, pad drivers, clutch plates, handle grips, filters, screens, throttle cables, brushes and carbon brushes.**

Subject to the conditions and exceptions stated in this warranty, Betco warrants the Betco products to be free from defects in material and workmanship, under normal use and service, for the periods listed under the warranty policy to the original purchaser. At any time during the warranty period, Betco will furnish replacement parts for the Betco parts to the original purchaser. Such parts will be furnished and charged including transportation costs, to the original owner through any Betco authorized Service Distributor. If the original part is returned within the warranty policy period from date of delivery for inspection by Betco and is found to be defective the owner will be credited for the cost of replacement parts plus shipping and handling. Replacement parts that have become defective through wear or abuse are not included in this warranty.

This warranty does not apply to damage or defect caused by accident, misuse, negligence, fire, or to any Betco product which has been serviced or repaired by other than an authorized Betco Service Distributor or Betco factory personnel. This warranty is void if products are used for any purpose other than that which was intended. There are no other warranties expressed or implied. In no event shall Betco be liable for incidental or consequential damages or any damage to person or property. (Please note some states do not allow the exclusion or limitations for incidental and consequential damages).

