



Electronic Service Manuals

This electronic document is provided as a service to our customers. We do not create the contents of the information contained in this document. Should you have detailed questions pertaining to the information contained in this document, you may contact Michco, or the manufacturer which provided the original information in this electronic deliverable. Michco's only part in this electronic deliverable was the electronic assembly process. By providing this manual online we are not guaranteeing parts availability.

You may contact Michco through the following methods:

Phone (517) 484-9312

2011 N. High St. -- Lansing, Michigan -- 48906

Fax: (517) 484-9836

Email: CustomerService@Michco.com

Website: www.Michco.Com

Order Parts online at:

www.Michco.Com

Directly to Parts & Service:

By Email: **CustomerService@Michco.com**

By Fax: (517) 484-9836

By Voice: (517) 484-9312

Serving the Cleaning Industry Since 1922

Notice: All copyrighted material remains property of original owners, all trademarks are property of respective owners. Manuals are subject to Manufacturer's reproduction limitations. Originals or reproductions were provided by manufacturers through a request. We make no warranty as to the correctness of information provided in this document and you assume all risk. By placing these manuals on line we are not declaring our corporation to be an manufacturer authorized dealer or provider, please check our web site for authorized manufacturers we represent.



E83025-00 E29937-00
E29936-00



CREWMAN™ AS20B

20" Automatic Scrubber
with Brush Assist



Operator Manual

TABLE OF CONTENTS

| | |
|----------------------------------|---------|
| RECEIVING THE MACHINE..... | 3 |
| TECHNICAL SPECIFICATIONS..... | 4 |
| GENERAL SAFETY REGULATIONS..... | 5 |
| MACHINE PREPARATION..... | 6 - 10 |
| OPERATION | 11 - 12 |
| TURNING OFF THE MACHINE | 13 |
| DAILY MAINTENANCE..... | 14 - 15 |
| WEEKLY MAINTENANCE..... | 16 |
| TROUBLESHOOTING | 17 |
| BRUSH AND SELECTION USE..... | 17 |
| PARTS DIAGRAMS AND LISTINGS..... | 18 - 39 |
| ELECTRICAL SYSTEM..... | 40 - 41 |
| WARRANTY | 44 |





RECEIVING THE MACHINE

Immediately check, when receiving the machine, that all the materials indicated on delivery documents have been received and also that the machine has not been damaged in transit. If it has been damaged, this damage must be immediately reported to the shipper and also to our customer's service department. Only acting promptly in this manner will make it possible to receive missing material and to be compensated for damage.

INTRODUCTION

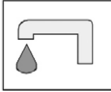
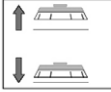
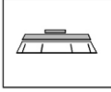
This is an automatic scrubber which, via the mechanical action of the rotating brush and the chemical action of a water/detergent solution, can clean many types of hard flooring. As it advances, it also collects the dirt removed and the detergent solution not absorbed by the floor.

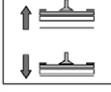
The machine must be used only for this purpose. Even the best machines will only work well if used correctly and kept in good working order. We therefore suggest you read this instruction booklet carefully and re-read it whenever difficulties arise while using the machine. Please contact our technical service department or your dealers if you have any questions about the machine.

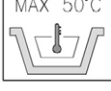
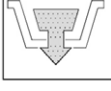
| SYMBOLS USED ON THE MACHINE | |
|---|---|
|  | Cock symbol Indicates the cock lever Indicates the cock open signal lamp |
|  | Brush base lift/lower symbol Indicates the base lift lever |
|  | Brush symbol Indicates the brush motor switch |
|  | Suction motor symbol Indicates the suction motor switch |
|  | Squeegee lift/lower symbol Indicates the squeegee lift lever |
|  | Battery symbol |
|  | Indicator of the battery charge level |
|  | Indicates the detergent solution maximum temperature |
|  | Indicates the recovery tank outlet pipe |

| TECHNICAL DESCRIPTION | Measurement Unit | Crewman™ AS20B |
|--|--|---------------------------------------|
| Working width | In (mm) | 20 (508) |
| Rear squeegee width | In (mm) | 26 (660) |
| Work capacity | ft ² /h (m ² /h) | 18,500 (1720) |
| Brush & Pad (diameter) | in (mm) | 20 (500) |
| Brush RPM | RPM | 275 |
| Brush pressure | lb. (Kg) | 50 (22) |
| Brush motor | V / HP (V / W) | 24 / 0.54 (24 / 400) |
| Drive Type | | Semi-Automatic |
| Vacuum motor | V / HP (V / W) | 24 / 0.5 (24 / 370) |
| Vacuum motor suction | inches of water (mbar) | 40 (100) |
| Solution tank capacity | Gal (l) | 9 (33) |
| Recovery tank capacity | Gal (l) | 10.5 (40) |
| Weight of machine (excluding batteries) | lb. (Kg) | 165 (75) |
| Charger | V / A | 24 / 12 |
| Battery compartment dimensions (Length / Height / Width) | in x in x in (mm/mm/mm) | 14.2 x 12.8 x 10.0 (360 /325 /250) |
| Noise level | dBA | 65 |

GENERAL SAFETY REGULATIONS

The regulations below must be carefully followed in order to avoid harm to the operator and damage to the machine.

- Read all labels on the machine carefully. Do not cover them for any reason and replace them immediately if they become damaged.
- The machine must be used exclusively by authorized and trained personnel.
- When operating the machine be careful of other people.
- The machine is not designed for cleaning carpets.
- The power cable outlet must be provided with a proper ground.
- Avoid damaging the power cable of the battery charger by crushing, bending, cutting or stressing it.
- Whenever the power cable of the battery charger is damaged, immediately contact a BETCO service center.
- Do not mix different types of detergent as this may produce harmful gases.
- Do not set containers on the machine.
- Machine storage temperature is between -10°F and 130°F, never store outside under humid conditions.
- Operating conditions: room temperature between 33°F and 100°F with relative humidity between 30% to 95%.
- Only use the machine in closed areas and do not expose it directly to rain.
- Never use the machine in an explosive environment.
- Do not use the machine as a means of transport.
- Never use acidic chemicals which could damage the machine.
- Avoid running the brushes with the machine stopped; this could damage the floor.
- Never vacuum up flammable liquids.
- Never use the machine to gather dangerous powders.
- Use a powder fire extinguisher in case of fire. Do not use water.
- Do not hit against shelving or scaffolding. The operator must always be equipped with the appropriate safety device (gloves, shoes, helmet, glasses, etc.)
- Do not use the machine on surfaces with an inclination greater than the one shown on the serial plate.
- The machine is designed to wash and dry floors simultaneously. Signal the presence of wet floors with suitable signs.
- If the machine does not work properly, perform routine maintenance. Otherwise, request the assistance of the BETCO technical service.
- When replacing parts ask for ORIGINAL spare parts from your Authorized BETCO Dealer and/or Retailer.
- Always turn off the machine and disconnect the battery connector whenever maintenance is performed.
- Never remove guards that require tools for removal.
- **Never wash the machine with direct or pressurized jets of water or with corrosive substances.**
- Have your BETCO service center check the machine once a year.
- To prevent the formation of scale in the solution tank filter, do not store the machine with detergent solution in the tanks.
- Before using the machine make sure that all doors and covers are positioned as shown in this operating and maintenance manual.
- When your BETCO machine is ready to be retired, the machine must be disposed of properly. It contains oils and electronic components. The machine was built using totally recyclable materials.
- Use only brushes furnished with the machine or those specified in the user's manual. Use of other brushes can compromise safety.
- When removing the battery, unplug the battery connection, unplug the charger and disconnect the battery terminals.
- Before recycling the machine, remove the battery.

MACHINE PREPARATION

1. HANDLING THE PACKED MACHINE

Do not place more than two packages on top of each other.

The total weight is 220 lb. (100 kg).

The overall dimensions of the package are:

- A : 50 in (1260 mm)
- B : 26 in (660 mm)
- C : 48.4 in (1230 mm)

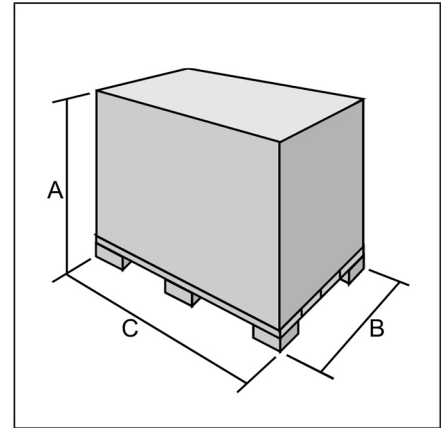

2. HOW TO UNPACK THE MACHINE

- A. Remove outer packaging.
- B. The machine is strapped to it's pallet.
- C. Remove the strap.

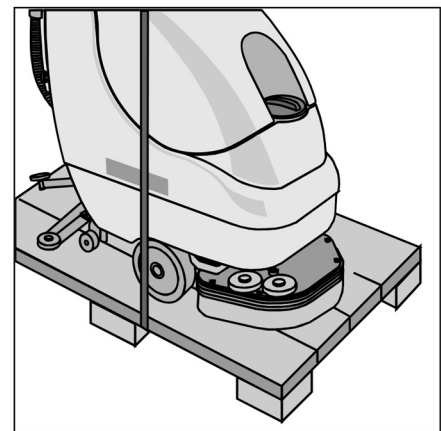

- D. Use a ramp to get the machine down from the pallet, pulling it backwards.
- E. Keep the pallet for any future transport needs.

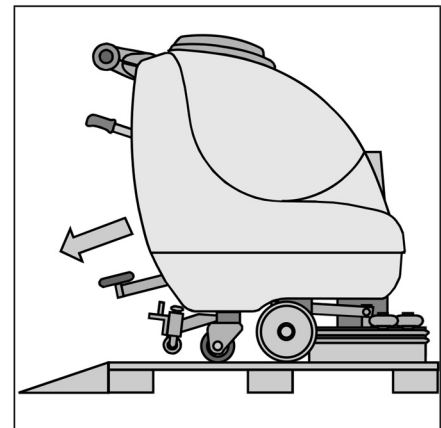

MACHINE PREPARATION

3. BATTERY INSTALLATION

The machine will be supplied with a battery charger and either two 12V Wet or AGM batteries. The batteries must be housed in the battery tray in the battery compartment beneath the recovery tank.

To insert the batteries you must:

- A. Open the recovery tank lid.
- B. Disconnect the squeegee hose (1) from the recovery tank.
- C. Remove the suction cap (2) by turning it counterclockwise.
- D. Disconnect the "recovery tank" drain hose from the proper hook.
- E. Remove the recovery tank.
- F. Place the battery.
- G. Connect the battery connector (2) to the machine connector (1).
- H. Reassemble everything.



WARNING: To avoid acid spillage you can use sealed batteries.

WARNING: Perform one battery charging cycle before using the machine.

4. BATTERY CHARGER

Make sure that the battery charger is suitable to the installed battery, both in capacity and in type (lead/acid or GEL and equivalent).



WARNING! Never charge a GEL battery with an unsuitable battery charger. Strictly follow the instructions provided by the battery and battery charger manufacturer.

In order to avoid permanent damages to the battery, they should never be totally discharged. To do this, they should be recharged within a few minutes after the battery discharge signal starts to flash.

NOTE: Never leave the battery completely discharged, even if the machine is not being used.

ATTENTION! For daily recharging of the battery it is necessary to strictly follow the instructions provided by the manufacturer or dealer. Specialists must carry out all installing and maintenance procedures. Danger of exhalation of gas and emission of corroding substances. Danger of fire: Keep away from flames.

MACHINE PREPARATION

5. BATTERY CHARGE LEVEL GAUGE

The batteries' indicator is digital with 4 fixed positions and a blinking one. The numbers, which appear on the display, show the approximate charge level.

4 = maximum charge, 3 = charge 3/4, 2 = charge 2/4, 1 = charge 1/4, 0 = (blinking) discharged batteries)



WARNING! Some seconds after that "0" blinks, the brush motor automatically switches off. Anyway, the machine can finish to dry before recharging the batteries.

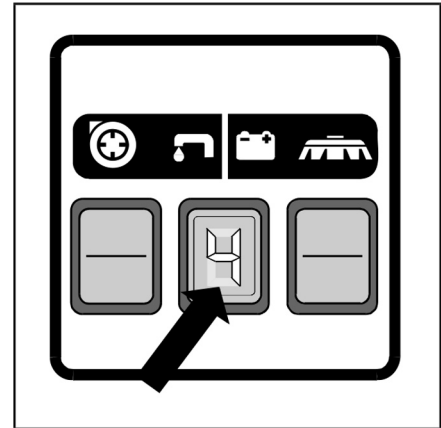

6. INSTALLING THE SQUEEGEE

The squeegee is supplied separately from the machine, due to packing reasons. It must be installed as shown in the picture, threading the retaining pin into the squeegee column. Put the squeegee suction hose into its sleeve.

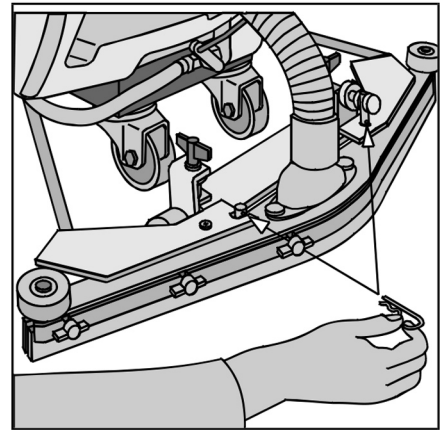

7. SQUEEGEE HEIGHT ADJUSTING

The squeegee height is maintained by the guide wheels. To adjust this: rotate the wing nuts (1) counterclockwise to lift the squeegee and clockwise to lower it.

Note: The right and left wheels must be set at the same height, to allow the squeegee to work parallel to the ground.

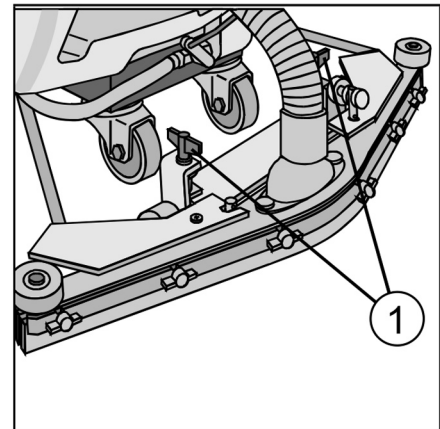

8. SQUEEGEE INCLINATION ADJUSTING

During operation, the back rubber is to be lightly inclined backwards (about 5 mm, on its whole length). Should it be necessary, you can increase the rubber central inclination by inclining backwards the squeegee body, turning the regulator counterclockwise (1). To increase the bending of the rubber on the squeegee sides, turn the register clockwise. Once the adjustment is finished, lock the block nut.

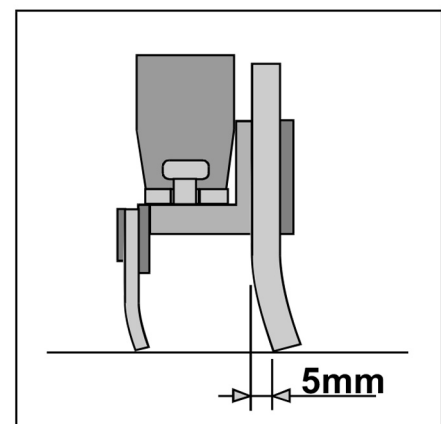

MACHINE PREPARATION

9. RECOVERY TANK

Open the cover and check if the suction plug (2) is insert correctly and its notches are locked turning the plug clockwise and is well connected with the hose which leads to the suction motor.
Furthermore check, that the squeegee hose (1) is well connected and that the exhaust plug at the back of the machine is closed.

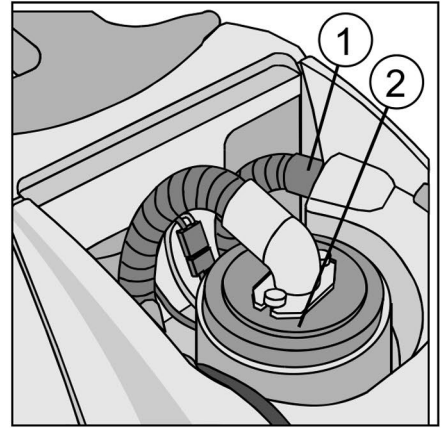

10. SOLUTION WATER

Fill the solution tank with clean water at a temperature not in excess of 120°F (50°C). Add liquid detergent in the amounts and using the procedures recommended by the detergent manufacturer. Use only a minimal percentage of detergent to prevent formation of an excessive quantity of foam, as this could damage the suction motor. Close the cap.



ATTENTION! Always use low-foam detergent. Introduce a small amount of anti-foam detergent in the recovery tank before operating, to be sure to prevent foam formation. Never use pure acids.

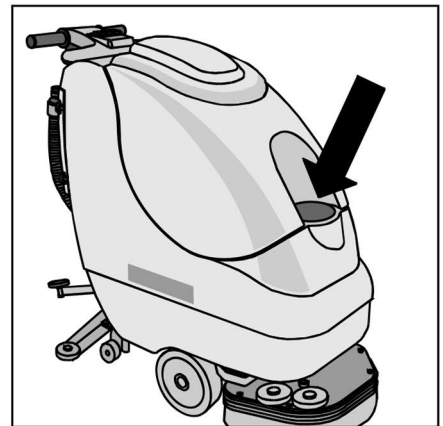

11. INSTALLING THE SPLASH-GUARD

The splashguard is supplied separately from the machine, for packing reasons, and is to be installed as shown in the picture.

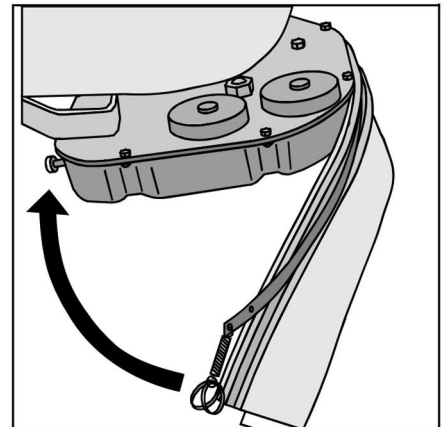

MACHINE PREPARATION

12. BRUSH ASSEMBLY

- A. Push the pedal in order to lift the brush base.
- B. With lifted brush base try to bring the brushes in the right position corresponding to the center of the machine.
- C. Let the brush base down by releasing on the pedal.

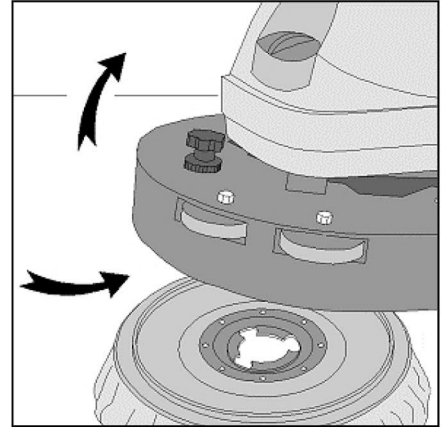

- D. Press the operator present control lever **(6)** and the brush will be hooked automatically.

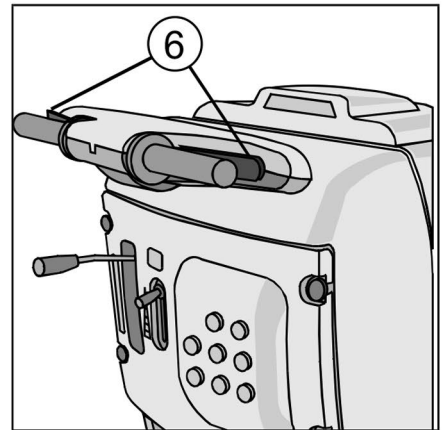

- E. In order to vary the advancement speed act upon the knob indicated in the illustration.

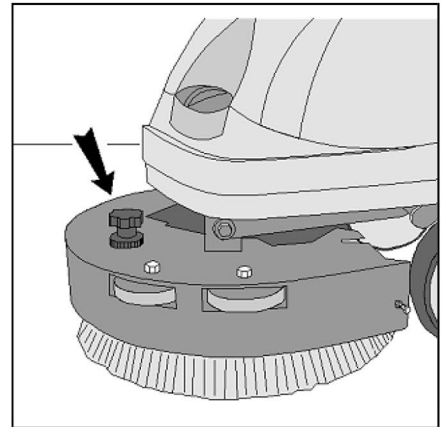

OPERATION

1. MACHINE OPERATION

A. Connect the battery cable (1).

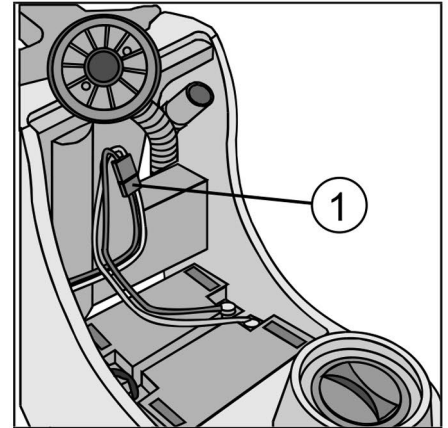

B. Press the brush switch (2).

C. Press the suction switch (3).

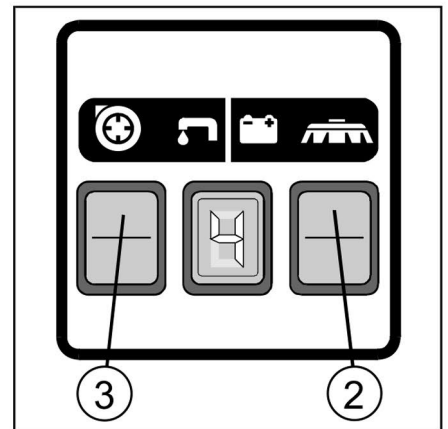

D. Use the solution knob (4) to adjust the detergent solution quantity: it should be enough to regularly wet the floor but not as much as to flow out the splashguard. Please note the right solution quantity depends on floor type, on dirt importance and on speed.

E. Release the pedal and let the base lower.

F. Lower the squeegee using the lever (5).

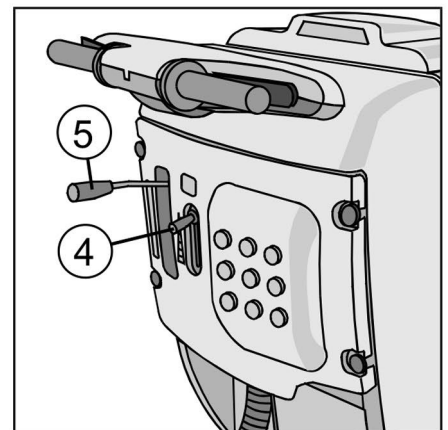

G. Pulling the trigger will cause (6) the brushes to start turning and the squeegee starts drawing in.

H. During the first few feet check that the amount of water is sufficient and that the squeegee dries the floor perfectly.

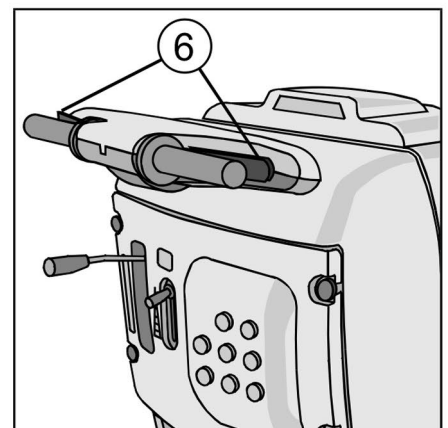

OPERATION

2. OVERFLOW DEVICE

The machine is supplied with float that trips whenever the recovery tank is full, closing the suction tube. In this case you should empty the recovery tank by removing the outlet pipe cap.



ATTENTION! Always wear gloves during this procedure, to avoid any contact with dangerous substances.

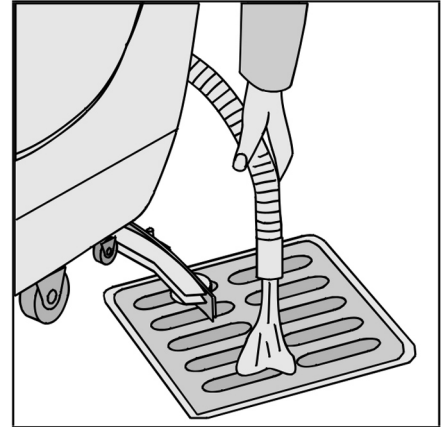

SHUTTING DOWN THE MACHINE

At the end of the work, and before performing any type of maintenance:

1. Close the solution valve(1).
2. Raise deck by pressing on foot pedal.
3. Raise squeegee lever (2).

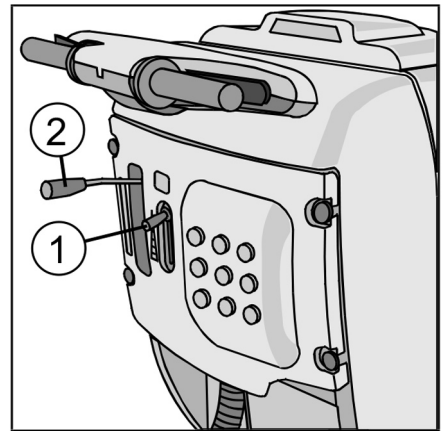

4. Turn off the brush switch (3).
5. Turn off suction motor switch (4).



ATTENTION! If after having switched off the brush switch (3) the display of the battery indicator remains on, this means that, the solution valve is open. Close the water valve using the lever (1) in order to avoid leakage of the detergent solution.

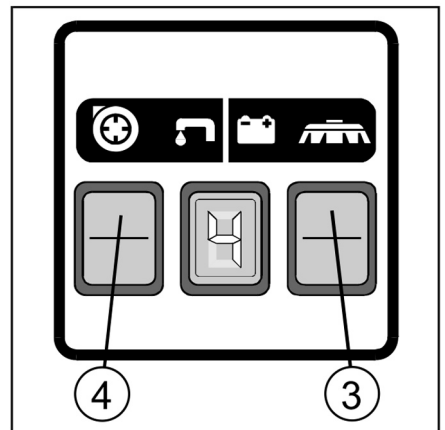

6. Move the machine to the water disposal point.

7. Hold the hose placed on the back of the machine.
8. Remove the outlet cap and empty the tank.



ATTENTION! Always wear gloves during this procedure to avoid any contact with dangerous substances.

9. Disassemble the brush and clean it by a jet of water (for the disassembly of the brush see the following "DISASSEMBLY OF THE BRUSH").

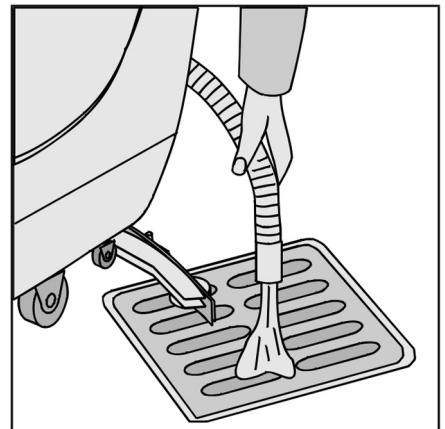

DAILY MAINTENANCE

1. RECOVERY TANK CLEANING

- A. Hold the recovery tank outlet hose.
- B. Remove the outlet cap and empty the tank.



ATTENTION! Always wear gloves during this procedure, to avoid any contact with dangerous substances.

- C. Lift the recovery tank lid.
- D. Remove the suction cap (1) turning it counterclockwise.
- E. Remove the filter and its protection.
- F. Rinse the tank with a jet of water.

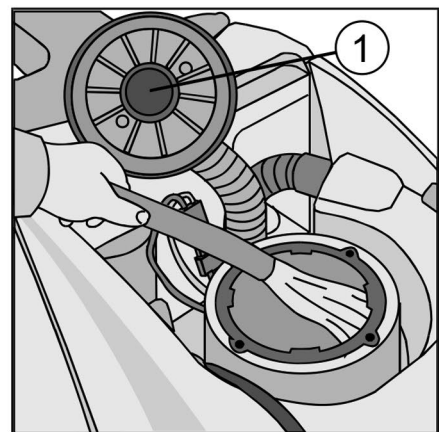
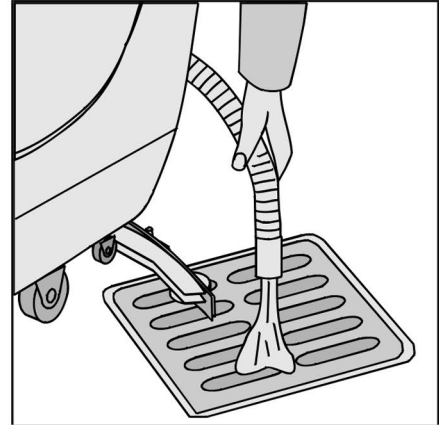

2. SUCTION FILTER CLEANING

- A. Lift the lid.
- B. Remove the suction cap turning in counterclockwise.
- C. Remove the filter.
- D. Clean the filter walls and bottom by a jet of water.
- E. Carry out the cleaning procedures very carefully.
- F. Reassemble everything.

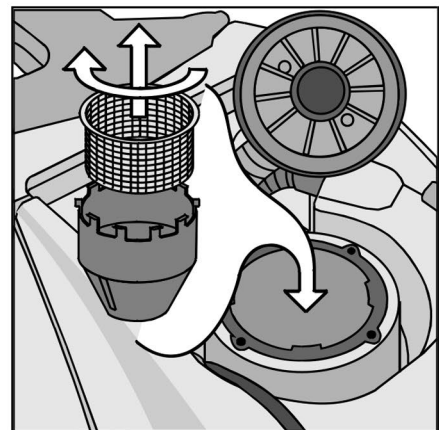

3. CLEANING THE VACUUM HOSE FILTER

The squeegee must be in perfect working condition to achieve a good drying process.

Proceed as follows to clean it:

- A. Remove the hose from the squeegee.
- B. Loosen the knobs (1) shown in picture.
- C. Remove the mouth and clean it.
- D. Carefully clean the inside of the squeegee.
- E. Carefully clean the squeegee blades.
- F. Reassemble everything.

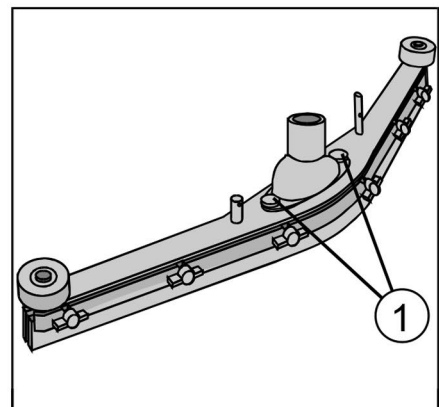

DAILY MAINTENANCE

4. BRUSHES DISASSEMBLY

- A. Lift the brush base through the pedal (push down).
- B. With brush base in lifted position operate the operator control lever, and the brush will unhook automatically.

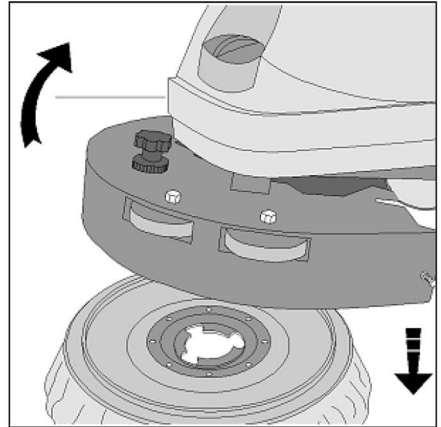

5. CLEANING SOLUTION FILTER

- A. Take off the filter on the solution tank.
- B. Clean it thoroughly.
- C. Reassemble everything.



ATTENTION! Always wear gloves during this procedure, to avoid any contact with dangerous substances.

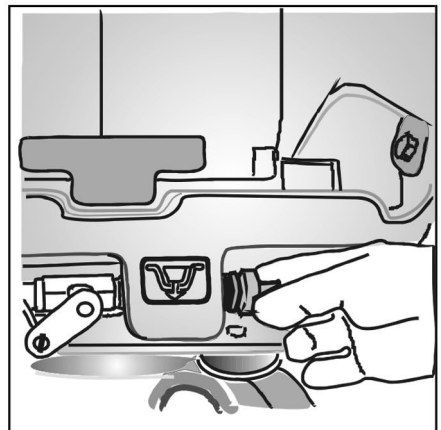

WEEKLY MAINTENANCE

1. CLEANING SQUEEGEE HOSE

Weekly, or whenever the suction is insufficient, it is necessary to check that the squeegee hose is not obstructed. Should it be the case, proceed as follows to clean it:

- A. Unthread the hose from the squeegee sleeve.
- B. Unthread the other end from the recovery tank.

- C. Wash the inside of hose by a jet of water.
- D. To reassemble the hose repeat the above-mentioned operations.



ATTENTION! Do not wash the hose connecting the vacuum motor to the suction cap.

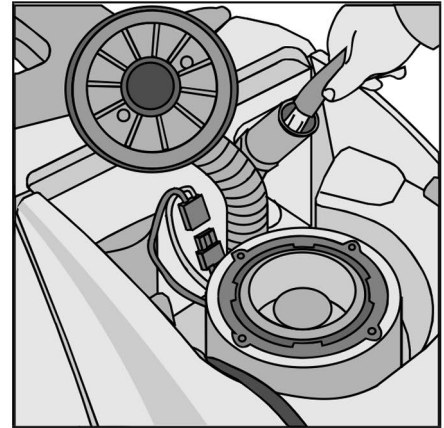

2. CLEANING SOLUTION TANK

- A. Remove the cap from the solution tank.
- B. Rinse with a jet of water.
- C. Remove the outlet cap (1) and empty the tank.



ATTENTION! Always wear gloves during this procedure, to avoid any contact with dangerous substances.

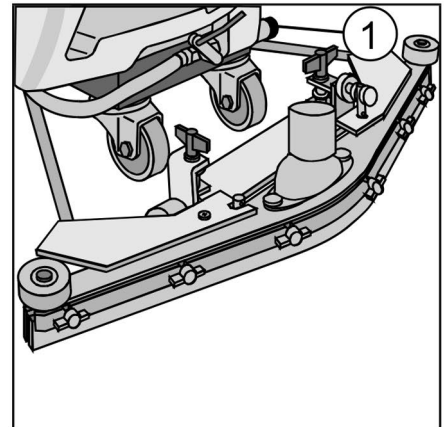

3. REAR SQUEEGEE BLADE REPLACEMENT

Check the squeegee blade wear and replace them if necessary. Proceed as follows:

- A. Unthread the squeegee hose from sleeve.
 - B. Remove the pin from column.
 - C. Remove the squeegee from its support.
 - D. Loosen the wing nuts (1) holding the squeegee blades and take them off.
 - E. Replace the squeegee blades.
- To reassemble the squeegee repeat the above-mentioned operations.

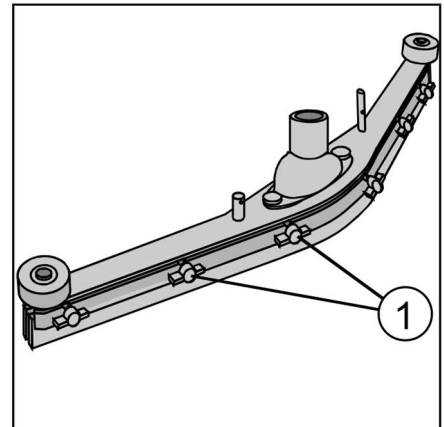

TROUBLESHOOTING GUIDE

INSUFFICIENT WATER TO THE BRUSHES

1. Check that the solution valve (1) is open.
2. Check that there is water in the solution tank.

THE MACHINE DOES NOT CLEAN PROPERLY

1. Check the brush wear and replace them if necessary (the brushes must be replaced when bristles are 15 mm high). To replace brushes see "BRUSHES DISASSEMBLY" and "BRUSH ASSEMBLY".
2. Use another type of brush rather than the standard brush. We recommend, for cleaning exceptionally difficult dirt floors, the use of special brushes, supplied on request and according to your specific needs (see "CHOICE OF BRUSHES AND COMMON ORDERED PARTS").

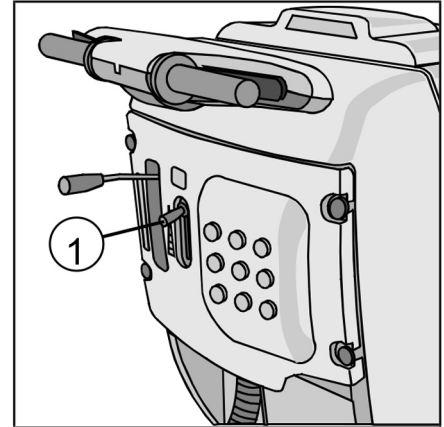

THE SQUEEGEE DOES NOT DRY EFFECTIVELY

1. Check that the squeegee blades are clean.
2. Adjust the squeegee inclination (see "SQUEEGEE" in "PREPARING THE MACHINE").
3. Check that the suction hose is correctly housed in its seat on the recovery tank.
4. Remove the whole suction unit and clean it.
5. Replace the blades if worn.
6. Check that the suction motor switch is turn on.
7. Check the squeegee height wheels.

TOO MUCH FOAM IS GENERATED

Check that low-foam detergent is used. Add, if necessary, a small quantity of defoaming liquid to recovery tank. Please remember that more foam is generated when the floor to be cleaned it is not very dirty. In this case use a more diluted detergent solution.

CHOICE OF BRUSHES AND COMMON ORDERED PARTS

CREWMAN™ AS20B BRUSH OPTIONS

| Item Number | Description |
|-------------|--------------------------------------|
| E88268-00 | Pad Driver |
| E88330-00 | Brush, General Purpose 20" 0.3mm PPL |
| E88269-00 | Brush, Medium Duty 20" 0.55mm PPL |
| E88270-00 | Brush, Heavy Duty 20" 0.7mm PPL |
| E88271-00 | Brush, Stripping Grit 20" 1.2mm |

CREWMAN™ AS20B COMMON PARTS

| Item Number | Description |
|-------------|---|
| E83909-00 | Front Squeegee Blade, Polyurethane 30" x 1 3/4" x 1/8" |
| E12686-00 | Wiping Squeegee Blade, Gum Rubber 30 3/4" x 1 3/4" x 1/8" |
| E88276-00 | Wiping Squeegee Blade, Polyurethane 30 3/4" x 1 3/4" x 1/8" |
| E12560-00 | Support Blade, Polyurethane 30 3/4" x 1 3/4" x 1/8" |
| E11767-00 | Battery 12V 130AH Wet |
| E86276-00 | Battery 12V 115AH Wet |
| E88030-00 | Battery 12V 110AH AGM |
| E88035-00 | Charger 24VDC 12AMP |

BRUSH DECK PARTS LISTING

| Item# | Part # | Description | Qty. |
|--------------|---------------|-------------------------|-------------|
| 1 | E88272 | Brush Deck Splash Guard | 1 |
| 2 | E20073 | Brush Deck | 1 |
| 3 | E83970 | Bushing | 3 |

| Item# | Part # | Description | Qty. |
|--------------|---------------|----------------------------|-------------|
| 4 | E83802 | Hex Bolt M8x30 Zinc | 3 |
| 5 | E81709 | Nyloc Hex Nut, M8 Zinc | 3 |
| 6 | E83404 | Flat Washer M9x24x2.5 Zinc | 8 |

BRUSH DECK DRIVE PARTS LISTING

| Item# | Part # | Description | Qty. |
|-------|--------|--------------------------------------|------|
| 1 | E20011 | Motor Mount Plate | 1 |
| 2 | E82312 | Bushing | 2 |
| 3 | E83833 | Hex Bolt M8x25 Zinc | 2 |
| 4 | E83404 | Flat Washer M9x24x2.5 Zinc | 2 |
| 5 | E81709 | Nyloc Hex Nut, M8 Zinc | 6 |
| 6 | E83895 | Wheel 80 OD x 23 W | 2 |
| 7 | E83524 | Bushing | 2 |
| 8 | E81918 | Flat Washer M9x32x2.5 Zinc | 2 |
| 9 | E81874 | Flat Washer M8x17x1.6 Zinc | 4 |
| 10 | E83830 | Hex Bolt M8x40 Zinc | 2 |
| 11 | E82309 | Spring, Compression | 2 |
| 12 | E83331 | Knob | 1 |
| 13 | E83547 | M6x16 Bolt, Zinc Hex Head 4 | |
| 14 | E82774 | Lock Washer, M6 Zinc | 4 |
| 15 | E20093 | Carriage Bolt M8x25 Zinc | 1 |
| 16 | E20297 | Flat Hd Soc Machine Screw M8x16 Zinc | 3 |
| 17 | E82844 | Clutch Plate | 1 |

| Item# | Part # | Description | Qty. |
|-------|--------|------------------------------------|------|
| 18 | E82845 | Spacer | 3 |
| 19 | E88245 | Motor, Geared 24V 400W 140 RPM | 1 |
| 19.11 | E20451 | Fitting, Solution Delivery Tube | 1 |
| 20 | E83565 | Knob | 1 |
| 21 | E88246 | Brush, Flange Threaded | 1 |
| 23 | E83491 | Spring | 1 |
| 24 | E83881 | Hex Bolt M5x20 Zinc | 1 |
| 25 | E88010 | Hex Nut, M5 | 4 |
| 26 | E83489 | Rings | 1 |
| 27 | E20290 | Flat Hd Soc Machine Screw M5x16 SS | 2 |
| 28 | E20507 | Brush Deck | 1 |
| 29 | E20584 | Retainer | 1 |
| 31 | E86169 | Band Clamp | 1 |
| 32 | E83823 | Screw M5x20/ SS Custom | 1 |
| 33 | E20592 | Dowel Pin M8 | 1 |
| 34 | E83672 | Hex Jam Nut, M8x5 SS | 1 |

FRAME ASSEMBLY DIAGRAM

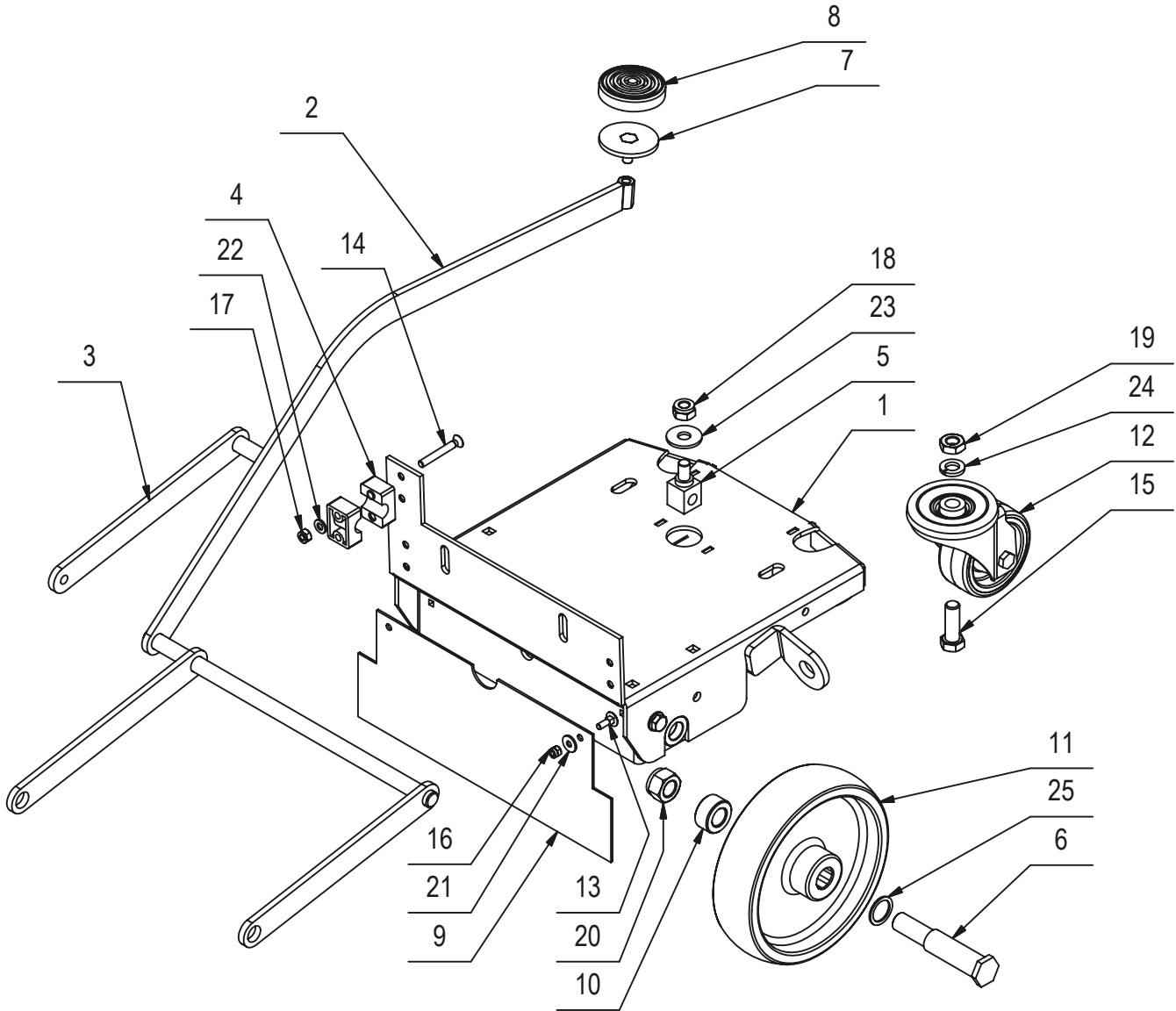

FRAME ASSEMBLY PARTS LISTING

| Item# | Part # | Description | Qty. |
|-------|--------|-------------------------------|------|
| 1 | E20430 | Main Frame ASM | 1 |
| 2 | E82525 | Arm s42 | 1 |
| 3 | E82833 | Arm | 1 |
| 4 | E82834 | Pivot Block | 6 |
| 5 | E22146 | Coupling | 1 |
| 6 | E20647 | Axle Shaft | 2 |
| 7 | E20370 | Foot Pedal | 1 |
| 8 | E83669 | Pedal cover | 1 |
| 9 | E20501 | SPLASH GUARD | 1 |
| 10 | E88103 | Spacer | 2 |
| 11 | E82551 | Transport Wheel 175 OD x 45 W | 2 |
| 12 | E82529 | Caster, Rear Abila | 2 |
| 13 | E20488 | Carriage Bolt M5x16 Zinc | 2 |

| Item# | Part # | Description | Qty. |
|-------|--------|------------------------------|------|
| 14 | E81635 | Screw, M6X45 | 6 |
| 15 | E81735 | Hex Bolt M12x35 Zinc | 2 |
| 16 | E20705 | Nyloc Hex Nut, M5 Zinc | 2 |
| 17 | E83550 | NyLoc Hex Nut, M6 Zinc | 6 |
| 18 | E83381 | Nyloc Hex Nut, M10 Zinc | 1 |
| 19 | E83829 | Hex Jam Nut, M12X7 Zinc | 2 |
| 20 | E81627 | Nyloc Hex Nut, M16 Zinc | 2 |
| 21 | E20122 | Flat Washer M5 x 15 x 1.5 SS | 2 |
| 22 | E82761 | Washer 6x12x1.6 | 6 |
| 23 | E81020 | Washer, 11x30X2.5 | 1 |
| 24 | E81738 | Flat Washer M4x12x3 Zinc | 2 |
| 25 | E81948 | Flat Washer M20x26x1.5 AL | 2 |

SQUEEGEE ASSEMBLY DIAGRAM

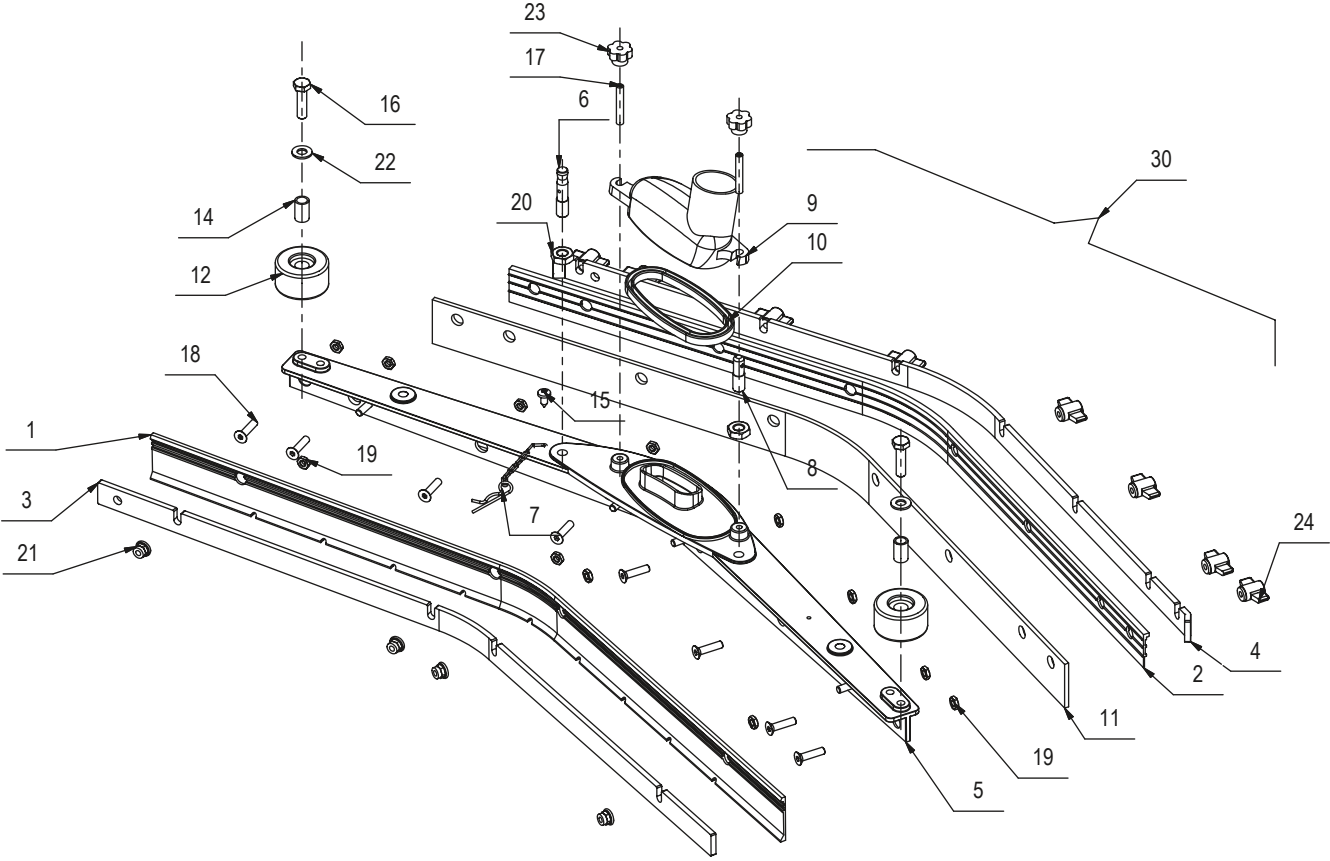

SQUEEGEE ASSEMBLY PARTS LISTING

| Item# | Part # | Description | Qty. |
|-------|--------|--|------|
| 1 | E83909 | Squeegee Blade, Polyurethane 30" x 1 3/4" x 1/8" | 1 |
| 2 | E12560 | Squeegee Blade, Polyurethane 30 3/4" x 1 3/4" x 1/8" | 1 |
| 3 | E82608 | Band Clamp 29 1/2" x 7/8" x 1/8" | 1 |
| 4 | E82676 | Band Clamp 31 1/4" x 7/8" x 1/8" | 1 |
| 5 | E88240 | Squeegee Body | 1 |
| 6 | E83911 | Stud Bolt M10x46 Custom | 1 |
| 7 | E83590 | Chain | 1 |
| 8 | E83945 | Stud Bolt M10x33 Custom | 1 |
| 9 | E82307 | Squeegee Vacuum Adapter | 1 |
| 10 | E83971 | Gasket | 1 |
| 11 | E12686 | Squeegee Blade, Gum Rubber 30 3/4" x 1 3/4" x 1/8" | 1 |
| 12 | E82451 | Wheel 45 OD x 25 W | 2 |
| 13 | E83914 | Hex Bolt M6x20 SS | 2 |

| Item# | Part # | Description | Qty. |
|-------|--------|---|------|
| 14 | E82253 | Bushing, Brass OD 11.95mm x ID 8.9mm x L 8.45mm | 1 |
| 15 | E83851 | Screw, Pan Hd Phil Self Tap M5.5x13 SS | 2 |
| 16 | E83802 | Hex Bolt M8x30 Zinc | 2 |
| 17 | E82707 | Set Screw Hex Soc Flat End M6x40 SS | 8 |
| 18 | E81848 | Flat Hd Soc Machine Screw M6x25 SS | 12 |
| 19 | E20114 | Hex Jam Nut, M6X3 SS | 2 |
| 20 | E83875 | Hex Jam Nut, M10X6 Zinc | 4 |
| 21 | E20117 | Nyloc Hex Jam Nut, M6x9 SS | 2 |
| 22 | E81874 | Flat Washer M8x17x1.6 Zinc | 2 |
| 23 | E83810 | Knob | 8 |
| 24 | E83591 | Knob | 1 |
| 30 | E88536 | Squeegee Assembly | 1 |

TANK ASSEMBLIES DIAGRAM

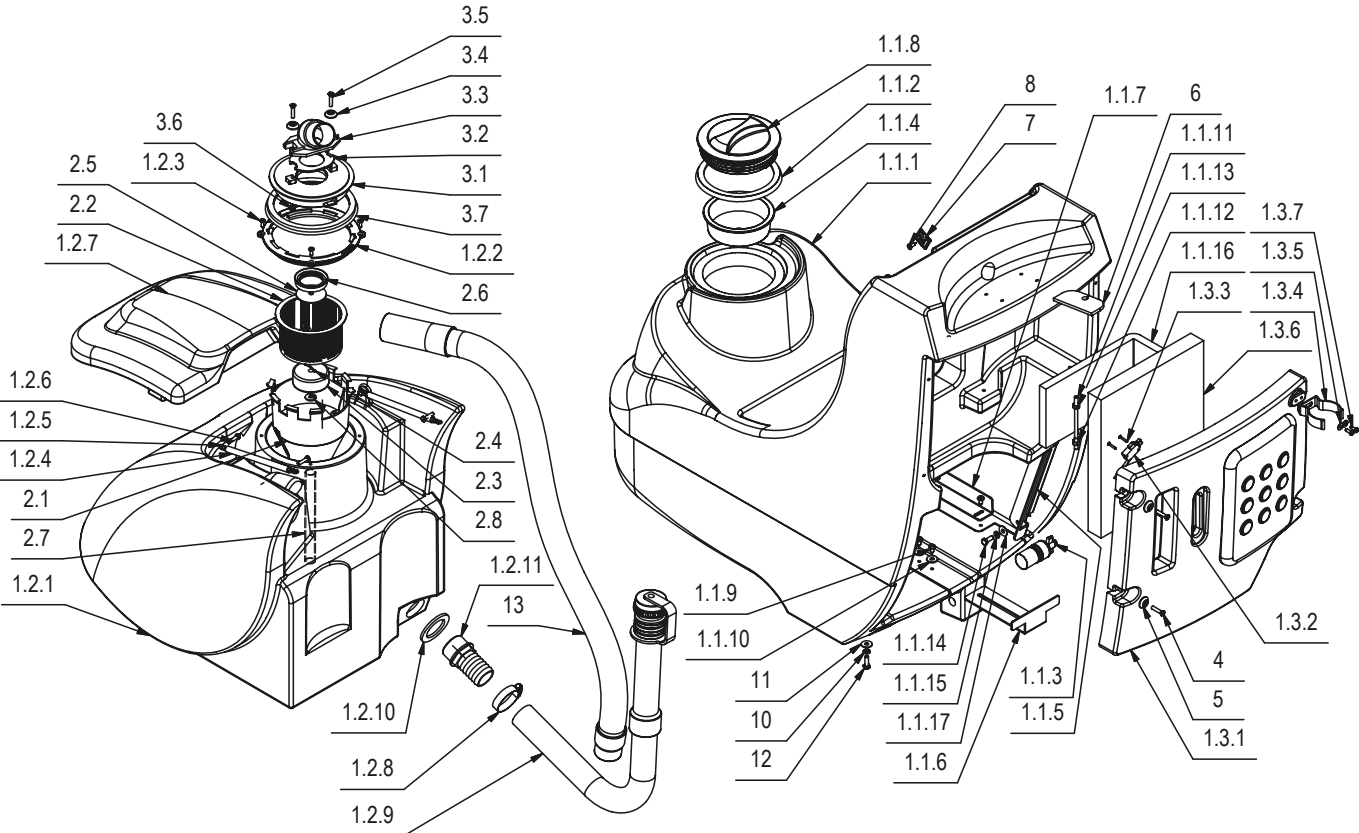

TANK ASSEMBLIES PARTS LISTING

| Item# | Part # | Description | Qty. |
|--------|--------|---|------|
| 1.1.1 | E84978 | Tank, Solution, Crewman AS20B (single disc) | 1 |
| 1.1.2 | E82332 | Gasket | 1 |
| 1.1.3 | E83560 | Filter Asm | 1 |
| 1.1.4 | E82612 | Filter | 1 |
| 1.1.5 | E83561 | Bracket WS17 | 1 |
| 1.1.6 | E83533 | Angle WS17 | 1 |
| 1.1.7 | E22147 | Support | 1 |
| 1.1.8 | E82429 | Cap | 1 |
| 1.1.9 | E83851 | Screw, Pan Hd Phil Self Tap M5.5x13 SS | 4 |
| 1.1.10 | E83799 | Flat Washer M6.6x18x2 SS | 2 |
| 1.1.11 | E81614 | Stud bolt | 2 |
| 1.1.12 | E86701 | Nut M6 | 2 |
| 1.1.13 | E83550 | NyLoc Hex Nut, M6 Zinc | 2 |
| 1.1.14 | E83547 | M6x16 Bolt, Zinc Hex Head | 2 |
| 1.1.15 | E82774 | Lock Washer, M6 Zinc | 2 |
| 1.1.16 | E83707 | Deadening WS17 | 1 |
| 1.1.17 | E82798 | Washer, 6x18x1.5 | 2 |
| 1.2.1 | E81470 | Abila Recovery Tank | 1 |
| 1.2.2 | E83995 | Ring | 1 |
| 1.2.3 | E83796 | Screw, Pan Hd Phil Self Tap M4.2x16 Zinc | 4 |
| 1.2.4 | E82254 | Chain Protector | 2 |
| 1.2.5 | E88430 | Support Chain Tank Cover | 2 |
| 1.2.6 | E83881 | Hex Bolt M5x20 Zinc | 4 |
| 1.2.7 | E82352 | Cover, Abila | 1 |
| 1.2.8 | E83966 | Hose Clamp | 1 |
| 1.2.9 | E88023 | Hose, Drain Assembly Abila 42 | 1 |
| 1.2.10 | E85764 | Gasket | 1 |
| 1.2.11 | E85763 | Connector | 1 |
| 1.3.1 | E22148 | Cover, Back Panel | 1 |
| 1.3.2 | E83164 | Micro Switch | 1 |
| .3.3 | E22293 | Screw | 2 |

| Item# | Part # | Description | Qty. |
|-------|--------|-------------------------------------|------|
| 1.3.4 | E87296 | Drain Hose Clip | 1 |
| 1.3.5 | E83037 | Flat Washer M4x12x1.6 Zinc | 2 |
| 1.3.6 | E85784 | Vac Motor Deadening | 1 |
| 1.3.7 | E20106 | Screw | 2 |
| 2 | E83123 | Float Protection Assembly | 1 |
| 2.1 | E81006 | Vacuum Splash Guard | 1 |
| 2.2 | E81615 | Filter | 1 |
| 2.3 | E83338 | Float WS17 | 1 |
| 2.4 | E83605 | Split pin | 2 |
| 2.5 | E82611 | Rod | 1 |
| 2.6 | E82313 | Grommet | 1 |
| 2.7 | E82490 | Hose, Abila | 1 |
| 2.8 | E83799 | Flat Washer M6.6x18x2 SS | 1 |
| 3 | E85756 | Recovery Tank Lid Assembly | 1 |
| 3.1 | E82450 | Cover | 1 |
| 3.2 | E83994 | Gasket | 1 |
| 3.3 | E82267 | Coupling | 1 |
| 3.4 | E83850 | Flat Washer M5x20 SS | 2 |
| 3.5 | E83934 | Screw m5x25 | 2 |
| 3.6 | E20705 | Nyloc Hex Nut, M5 Zinc | 2 |
| 3.7 | E82381 | Gasket Ring | 1 |
| 4 | E83934 | Screw m5x25 | 4 |
| 5 | E83850 | Flat Washer M5x20 SS | 4 |
| 6 | E22149 | Foam Pad | 2 |
| 7 | E81619 | Cable Tie Holder | 4 |
| 8 | E83796 | Screw, Pan Hd Phil Self Tap M4.2x16 | 4 |
| 9 | E20089 | Hex Bolt M6x22 Zinc | 2 |
| 10 | E82774 | Lock Washer, M6 Zinc | 4 |
| 11 | E82798 | Washer, 6x18x1.5 | 4 |
| 12 | E20088 | Hex Bolt M6x18 Zinc | 2 |
| 13 | E83536 | Squeegee hose | 1 |

SQUEEGEE CONTROL ASSEMBLY DIAGRAM

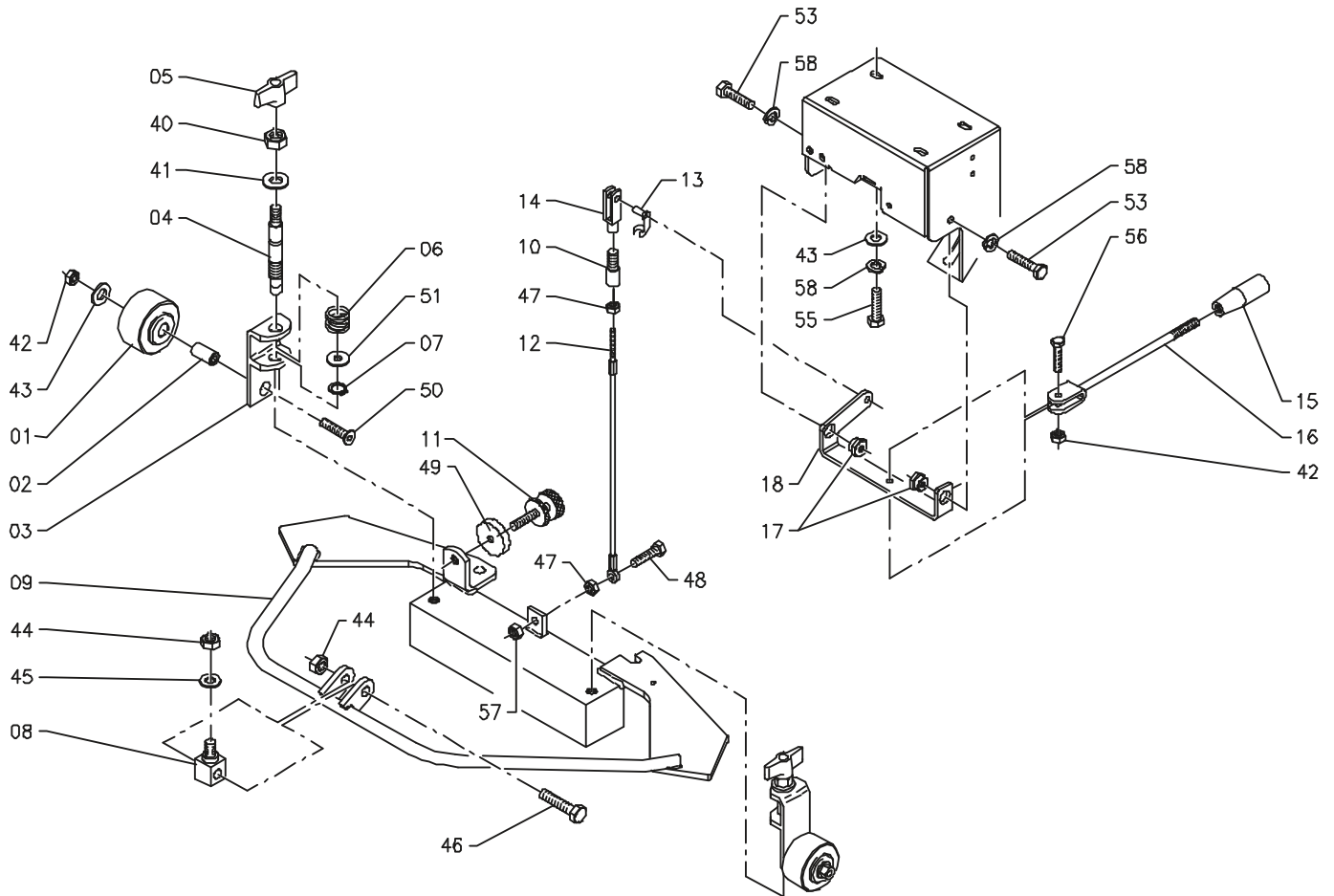

SQUEEGEE CONTROL ASSEMBLY PARTS LISTING

| Item# | Part # | Description | Qty. |
|-------|--------|----------------------------------|------|
| 1 | E82428 | Wheel 52 OD x 28 W | 2 |
| 2 | E82273 | Bushing | 2 |
| 3 | E85497 | Weldment, Squeegee Wheel Support | 2 |
| 4 | E82329 | Threaded Pin | 2 |
| 5 | E83531 | Knob | 2 |
| 6 | E81634 | Spring Compression | 2 |
| 7 | E85498 | Retaining Ring, E-Style, M9 | 2 |
| 8 | E22146 | Coupling | 1 |
| 9 | E86246 | Coupling, Squeegee | 1 |
| 10 | E83541 | Extension Tube | 1 |
| 11 | E83655 | Adjuster Knob | 1 |
| 12 | E83453 | Squeegee Lift Cable | 1 |
| 13 | E83542 | Clip WS17 | 1 |
| 14 | E83538 | Fork WS17 | 1 |
| 15 | E81477 | Knob 25X50 M8 | 1 |
| 16 | E82550 | Handle - Lever | 1 |
| 17 | E82698 | Bushing | 2 |
| 18 | E83540 | Lever | 1 |

| Item# | Part # | Description | Qty. |
|-------|--------|------------------------------|------|
| 40 | E85499 | Hex Nut, M8x6.5 SS | 1 |
| 41 | E81874 | Flat Washer M8x17x1.6 Zinc | 2 |
| 42 | E83550 | NyLoc Hex Nut, M6 Zinc | 2 |
| 43 | E88585 | Washer, Flat, M6 x 18, Zinc | 4 |
| 44 | E83381 | Nyloc Hex Nut, M10 Zinc | 1 |
| 45 | E81736 | Flat Washer M17x30x3 Zinc | 1 |
| 46 | E10646 | Bolt, M10 x 45 | 1 |
| 47 | E83535 | Hex Nut, M5x5 Zinc | 1 |
| 48 | E83881 | Hex Bolt M5x20 Zinc | 1 |
| 49 | E83656 | Hex Nut, M8x6.5 Zinc | 2 |
| 50 | E85721 | Screw, Machine M6 x50 | 2 |
| 51 | E85722 | Flat Washer M13x24x2.5 Zinc | 2 |
| 53 | E82456 | Hex Bolt M6x14 Zinc | 1 |
| 55 | E83547 | M6x16 Bolt, Zinc Hex Head | 1 |
| 56 | E82772 | Hex Bolt M6x20 Zinc | 1 |
| 57 | E82256 | Nyloc Hex Nut, M5x7 Zinc | 1 |
| 58 | E88594 | Washer, Split Lock, M6, Zinc | 3 |

VACUUM MOTOR ASSEMBLY DIAGRAM

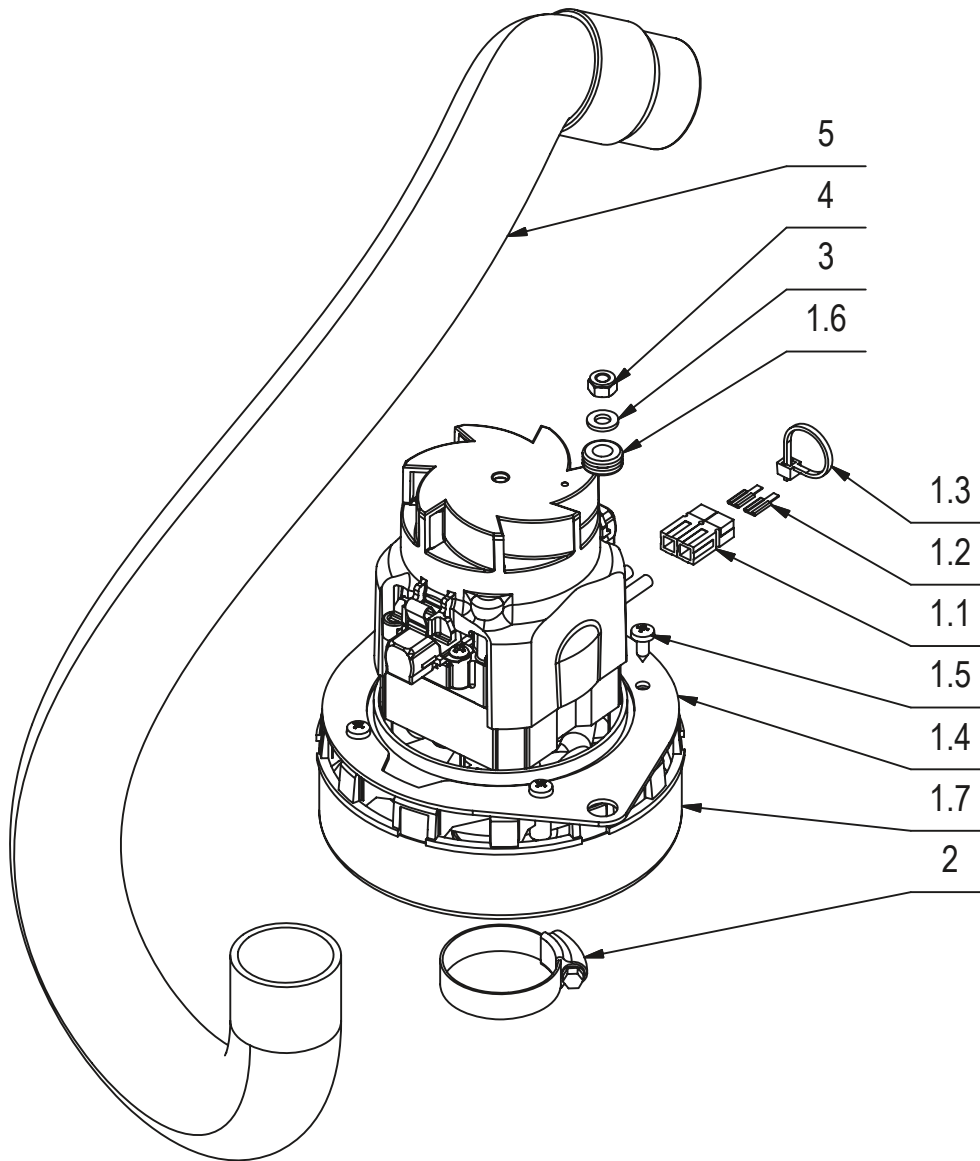

VACUUM MOTOR ASSEMBLY PARTS LISTING

| Item# | Part # | Description | Qty. |
|--------------|---------------|--|-------------|
| 1 | E83454 | Vacuum Motor, 24 volt | 1 |
| 1.1 | E83897 | Connector, Electrical Housing 30A | 2 |
| 1.2 | E83883 | Lug, Electrical 30A | 2 |
| 1.3 | E83935 | Wire Tie | 1 |
| 1.4 | E82838 | Motor Plaque | 1 |
| 1.5 | E88017 | Screw, Pan Hd Phil Self Tap M4.8x13 SS | 4 |

| Item# | Part # | Description | Qty. |
|--------------|---------------|------------------------|-------------|
| 1.6 | E87975 | Stud Bolt Tripla | 2 |
| 1.7 | E83454 | Vacuum Motor, 24 volt | 1 |
| 2 | E83966 | Hose Clamp | 1 |
| 3 | E82761 | Washer 6x12x1.6 | 2 |
| 4 | E83550 | NyLoc Hex Nut, M6 Zinc | 2 |
| 5 | E82371 | Vac exhaust hose | 1 |

SOLUTION ASSEMBLY DIAGRAM

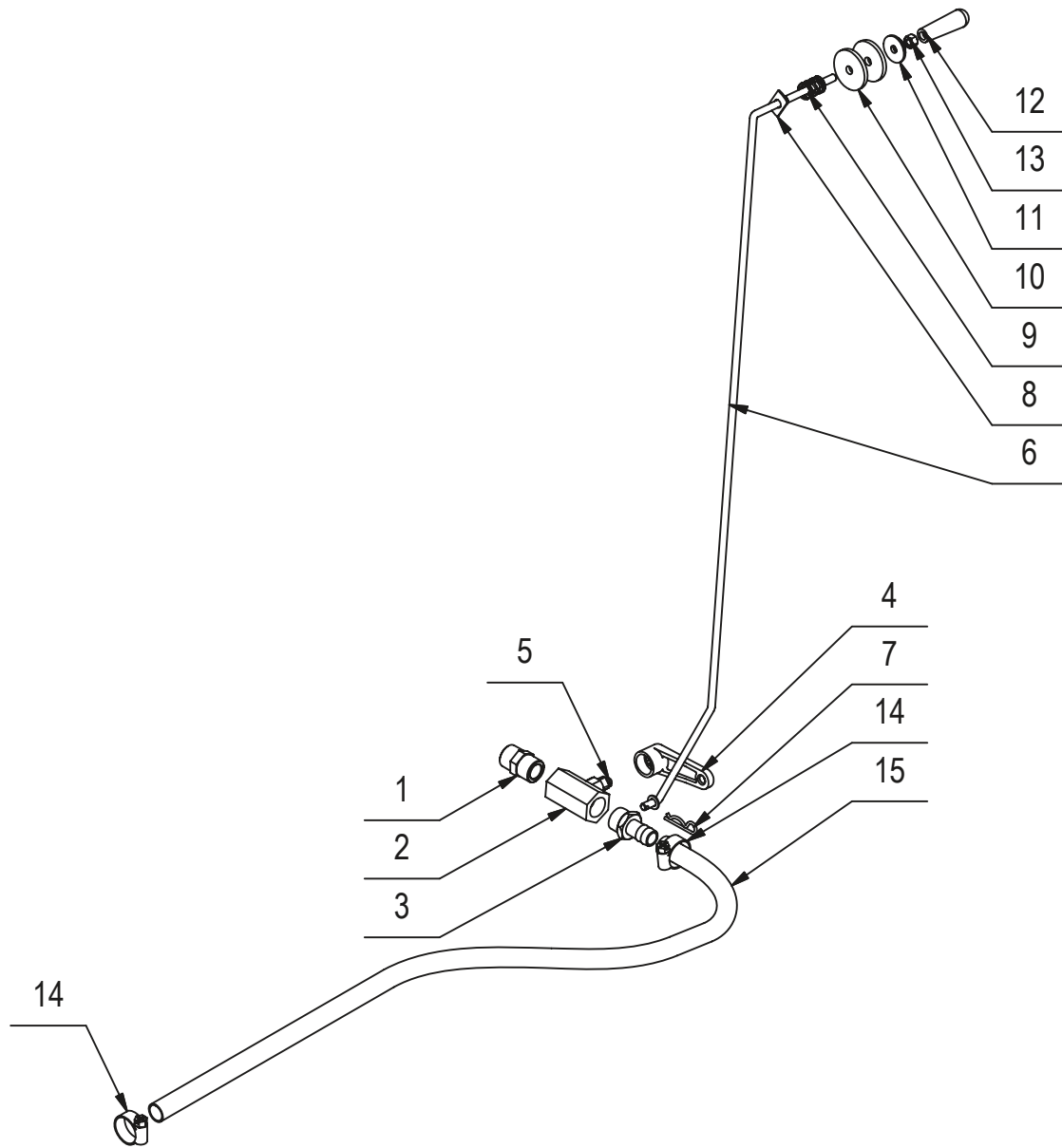

SOLUTION ASSEMBLY PARTS LISTING

| Item# | Part # | Description | Qty. |
|-------|--------|-------------------------------|------|
| 1 | E83943 | Nipple, Double Male 3/8" | 1 |
| 2 | E83361 | Ball Valve, 5/8 Double Female | 1 |
| 3 | E82269 | Barbed Fitting, 3/8 in. | 1 |
| 4 | E83534 | Solution valve lever | 1 |
| 5 | E83816 | Screw | 1 |
| 6 | E83532 | Solution rod | 1 |
| 7 | E83537 | Clip | 1 |
| 8 | E83845 | Nut, M5 | 1 |

| Item# | Part # | Description | Qty. |
|-------|--------|-------------------------------|------|
| 9 | E82309 | Spring, Compression | 1 |
| 10 | E83798 | Flat Washer M6x30x3 PVC Black | 2 |
| 11 | E83850 | Flat Washer M5x20 SS | 1 |
| 12 | E83639 | Solution control knob | 1 |
| 13 | E83535 | Hex Nut, M5x5 Zinc | 1 |
| 14 | E83499 | Hose Clamp | 2 |
| 15 | E82306 | Hose | 1 |

ELECTRIC COMPONENTS DIAGRAM

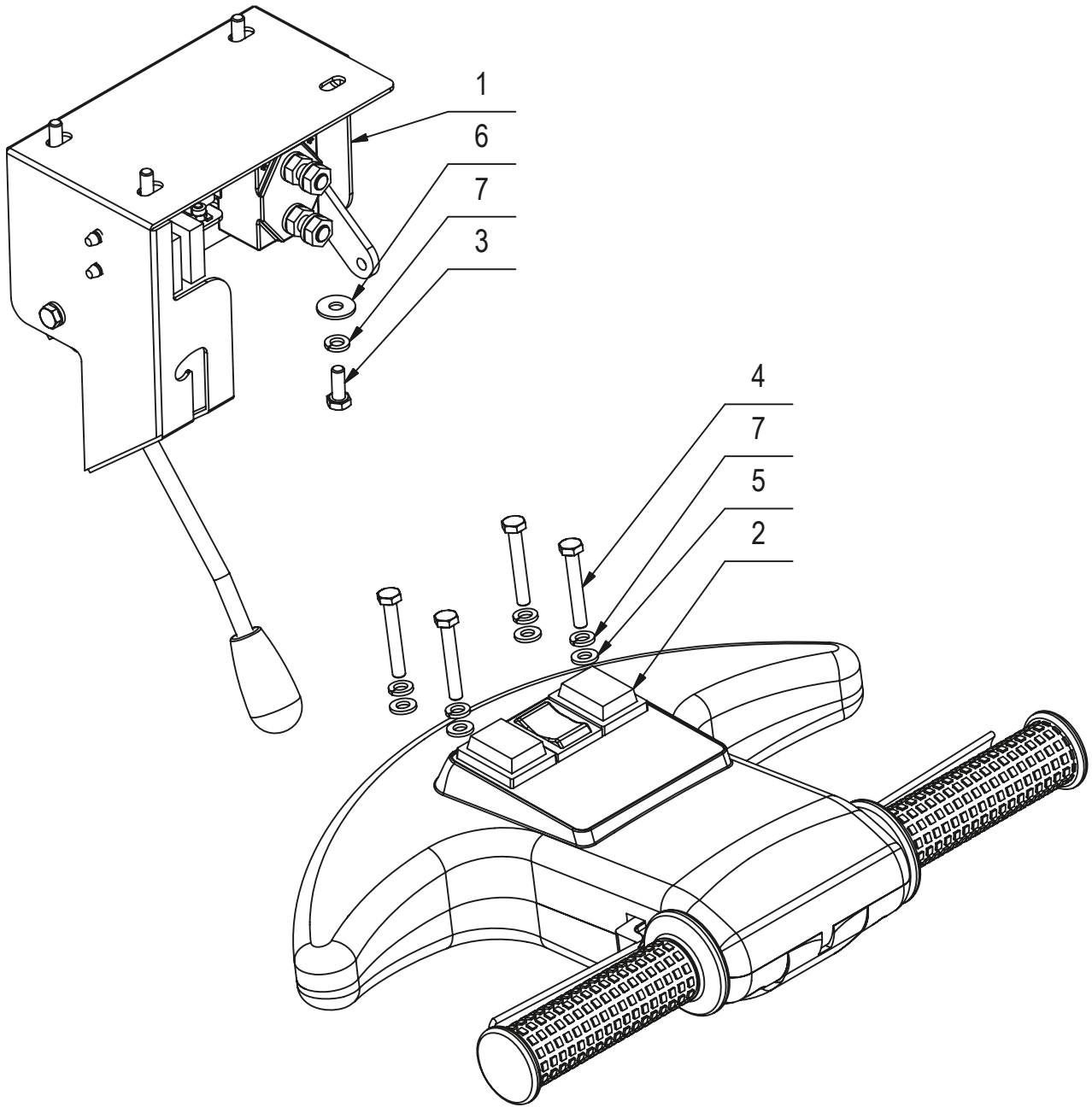

ELECTRIC COMPONENTS PARTS LISTING

| Item# | Part # | Description | Qty. |
|--------------|---------------|---------------------------|-------------|
| 1 | E22151 | Electric System | 1 |
| 2 | E22152 | Handlebar Assembly | 1 |
| 3 | E83547 | M6x16 Bolt, Zinc Hex Head | 4 |
| 4 | E81983 | Hex Bolt M6x40 Zinc | 4 |

| Item# | Part # | Description | Qty. |
|--------------|---------------|----------------------|-------------|
| 5 | E82761 | Washer 6x12x1.6 | 4 |
| 6 | E82798 | Washer, 6x18x1.5 | 4 |
| 7 | E82774 | Lock Washer, M6 Zinc | 8 |

HANDLEBAR ASSEMBLY DIAGRAM

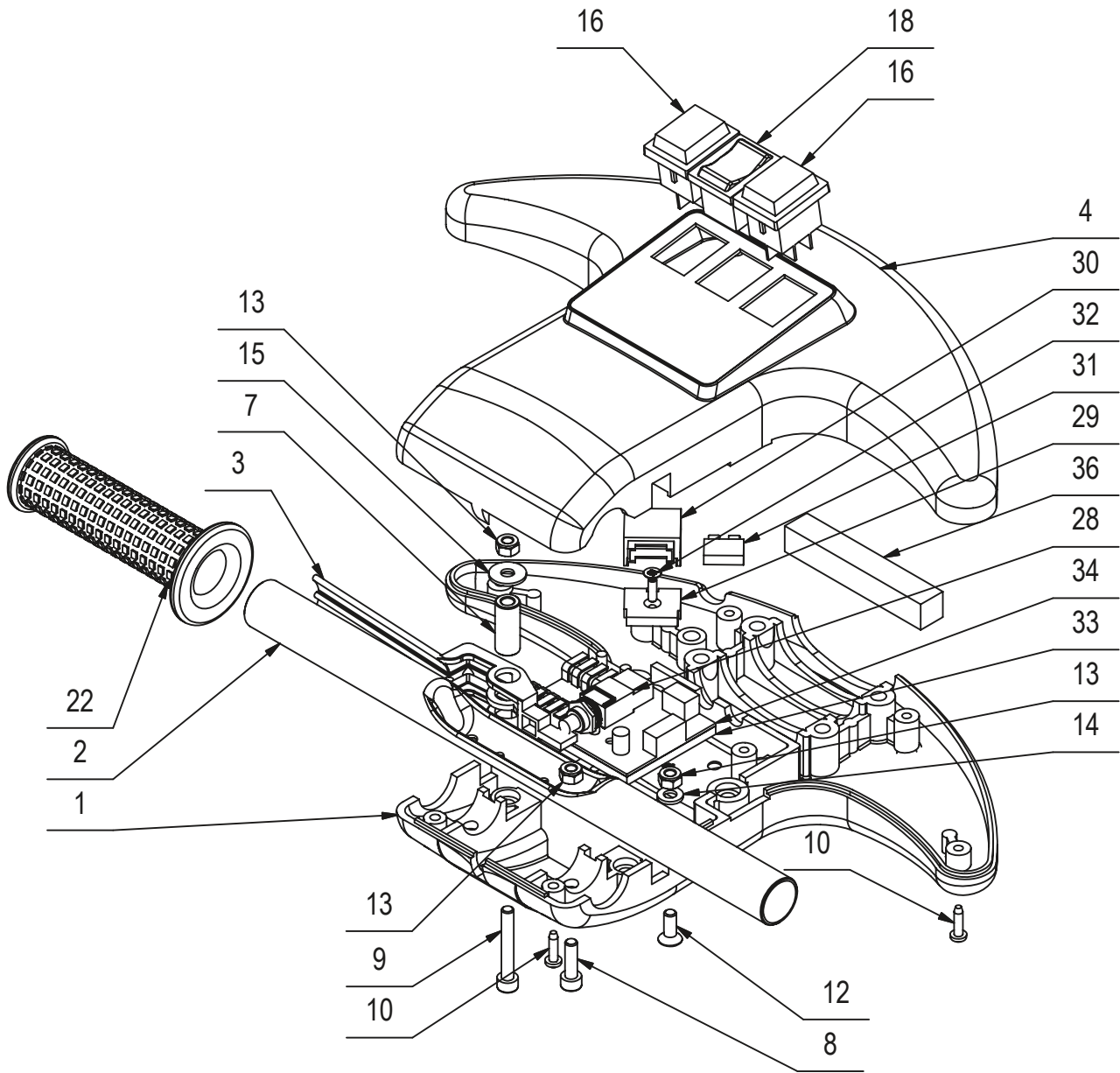

HANDLEBAR ASSEMBLY PARTS LISTING

| Item# | Part # | Description | Qty. |
|-------|--------|--|------|
| 1 | E83407 | Handle bar body WS17 | 1 |
| 2 | E83408 | Handle bar (pipe) WS17 | 1 |
| 3 | E83465 | WS17 lever | 2 |
| 4 | E83405 | Handle bar cover WS17 | 1 |
| 7 | E82308 | Pin | 2 |
| 8 | E20489 | Soc Hd Cap Screw M6x20 Zinc | 2 |
| 9 | E20342 | Soc Hd Cap Screw M6x40 Zinc | 2 |
| 10 | E20107 | Screw, Pan Hd Phil Self Tap M4.2x16 SS | 4 |
| 12 | E88042 | Flat Hd Soc Machine Screw M6x16 Zinc | 1 |
| 13 | E83550 | NyLoc Hex Nut, M6 Zinc | 5 |
| 14 | E82761 | Washer 6x12x1.6 | 1 |
| 15 | E82798 | Washer, 6x18x1.5 | 2 |

| Item# | Part # | Description | Qty. |
|-------|--------|-------------------------------|------|
| 16 | E83328 | Vacuum switch | 2 |
| 18 | E83175 | battery level display | 1 |
| 22 | E83615 | Handle grip WS17 | 2 |
| 28 | E82796 | Switch, Momentary | 1 |
| 29 | E22153 | Mounting Plate | 1 |
| 30 | E88244 | Fuse Holder for Crewman AS20B | 1 |
| 31 | E83168 | Fuse, 3 amp | 1 |
| 32 | E86144 | Screw, Battery Cover | 1 |
| 33 | E82704 | Gasket | 1 |
| 34 | E83157 | battery indicator card | 1 |
| 36 | E22154 | Spacer 15x15x92 | 1 |

ELECTRIC CONTROLS PARTS LISTING

| Item# | Part # | Description | Qty. |
|-------|--------|--------------------------|------|
| 1 | E22155 | Electric Panel | 1 |
| 2 | E83540 | Lever WS17 | 1 |
| 3 | E82550 | Handle - Lever S42 | 1 |
| 4 | E82698 | bushing | 2 |
| 5 | E82772 | Hex Bolt M6x20 Zinc | 1 |
| 6 | E83550 | NyLoc Hex Nut, M6 Zinc | 1 |
| 7 | E81477 | Knob 25X50 M8 | 1 |
| 8 | E82456 | Hex Bolt M6x14 Zinc | 2 |
| 9 | E82774 | Lock Washer, M6 Zinc | 2 |
| 10 | E83160 | Relay 24VDC 30A | 1 |
| 11 | E83867 | Nyloc Hex Nut, M4x6 Zinc | 1 |
| 12 | E83887 | Screw M4X10 | 1 |

| Item# | Part # | Description | Qty. |
|-------|--------|-------------------------------|------|
| 13 | E83628 | Contactora 24VDC | 1 |
| 14 | E81954 | Washer, Lock | 2 |
| 15 | E83816 | Screw | 2 |
| 16 | E82305 | Fuse 50A faston brushes motor | 1 |
| 17 | E83972 | Fuse 30A fasten | 1 |
| 18 | E81642 | Fuseholder | 2 |
| 19 | E88497 | Fuse Block End Cap | 1 |
| 20 | E83664 | Insulator WS17 | 1 |
| 21 | E20123 | Lock Washer M5x1.6 Zinc | 2 |
| 22 | E20122 | Flat Washer M5 x 15 x 1.5 SS | 2 |
| 23 | E81437 | Screw | 2 |

ELECTRICAL DIAGRAM

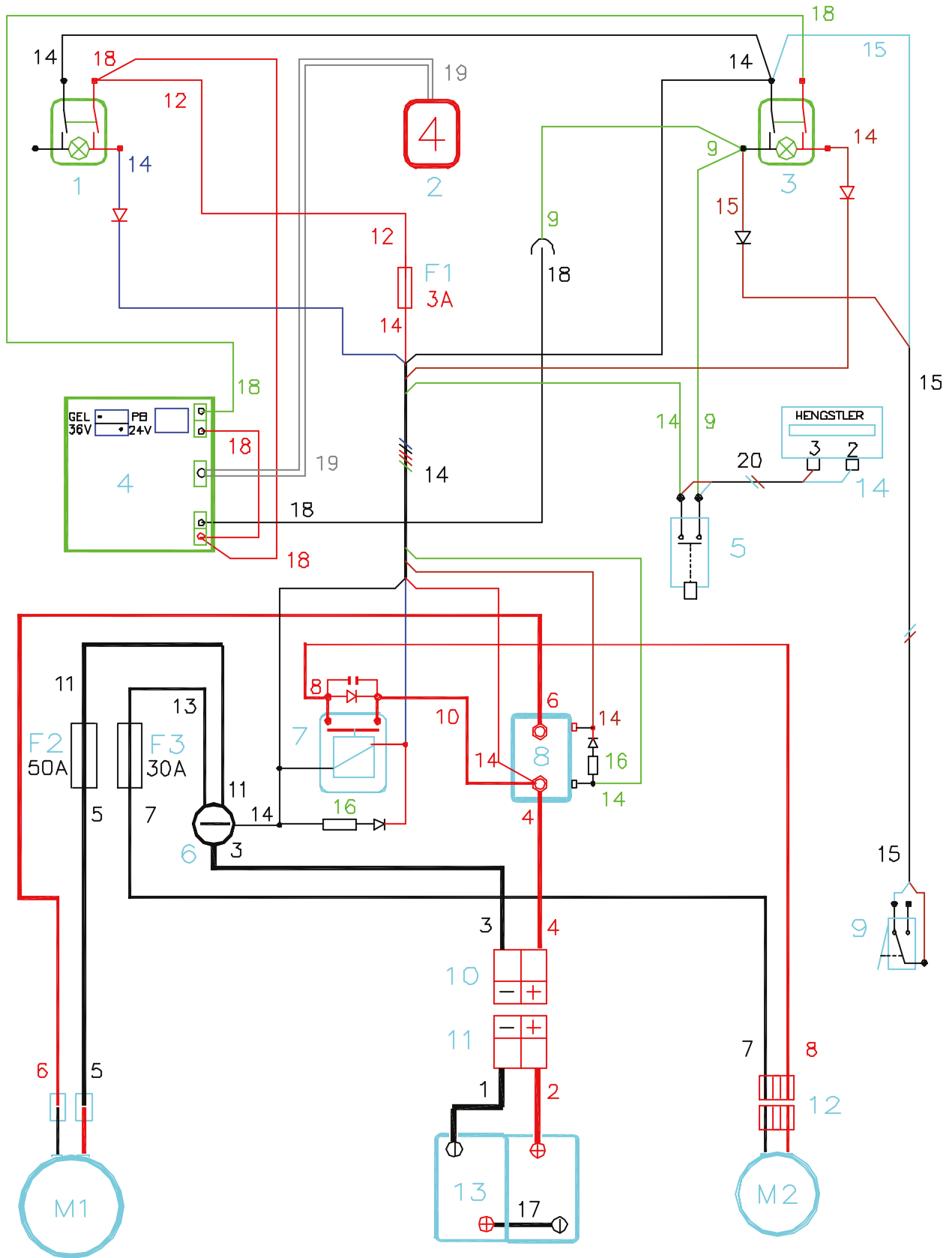

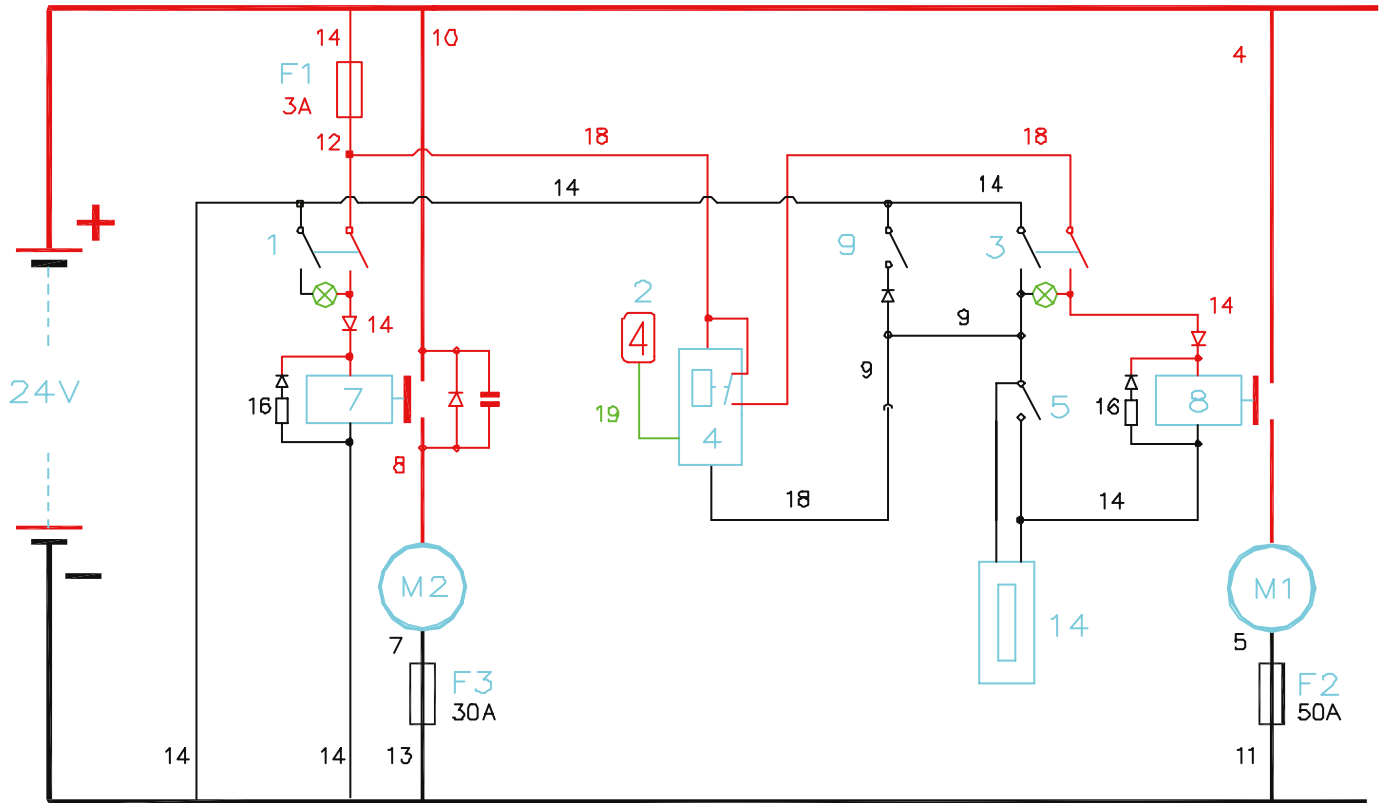

ELECTRICAL LISTING

| Item# | Part # | Description |
|-------|--------|------------------------|
| 1 | E83328 | Vacuum Switch |
| 2 | E83175 | Battery Level Display |
| 3 | E83328 | Vacuum Switch |
| 4 | E83157 | Battery Indicator Card |
| 5 | E82796 | Switch, Momentary |
| 6 | E83664 | Insulator |
| 7 | E83160 | Relay 24VDC 30A |
| 8 | E83628 | Contactora 24VDC |
| 9 | E83164 | Micro Switch |

| Item# | Part # | Description |
|-------|---------|-----------------------------------|
| 10 | E86208 | Connector, SB50, Red, #6, w/ Lugs |
| 11 | E86208 | Connector, SB50, Red, #6, w/ Lugs |
| 13 | Various | Battery |
| M1 | E88245 | Motor, Geared 24V 400W |
| M2 | E83454 | Vacuum Motor, 24 volt |
| F1 | E83168 | Fuse, 3 amp |
| F2 | E82305 | Fuse 50A Brush Motor |
| F3 | E83926 | Fuse 30A Vacuum Motor |

BETCO US WARRANTY POLICY

10 year coverage

Subject to the conditions stated below, Betco warrants parts and labor on rotationally molded polyethylene tanks/ housings and injection molded vacuum head assemblies to be free from defects in materials and workmanship for a period of ten years to the original purchaser.

3 Year Coverage

Subject to the conditions stated below, Betco warrants parts and labor on all other Betco components to be free from defects in materials and workmanship for a period of three years to the original purchaser.

- Lithium Ion battery for MotoMop™ is a full 3 years

1 Year Coverage

Subject to the conditions stated below, Betco offers a limited warranty on parts and labor on the following equipment: parts and accessories to be free from defects in materials and workmanship for a period of one year to the original purchaser.

- PowerUp™ 14 Upright Vacuum: #E29990-00
- Bac Pac Lite Vacuum: #85903-00
- FiberPRO® Floor Dryer: #85507-00
- WORKMAN™ Series Vacuums: #85024-00, #85025-00, #83012-00, #85027-00
- All Tools and Accessories
- All Battery Chargers
- Deep cycle batteries are pro-rated for 1 year

Allowable Travel Time Warranty Reimbursement:

Eligible equipment: All battery and propane powered equipment products. Warranty period: 90 days from date of sale to the original purchaser. A maximum 180 mile round trip at 50 cents per mile will be allowed for warranty consideration.

Propane Machine Warranty:

Kawasaki engines are warranted by Kawasaki for a period of 2 years against manufacturer defects. All other components (except wear items)* are warranted by Betco for a period of 3 years.

***Wear Items exempt from Warranty consideration include but may not be limited to: power cords, transport wheels, vacuum bags, belts, squeegee blades, pad drivers, clutch plates, handle grips, filters, screens, throttle cables, brushes and carbon brushes.**

Subject to the conditions and exceptions stated in this warranty, Betco warrants the Betco products to be free from defects in material and workmanship, under normal use and service, for the periods listed under the warranty policy to the original purchaser. At any time during the warranty period, Betco will furnish replacement parts for the Betco parts to the original purchaser. Such parts will be furnished and charged including transportation costs, to the original owner through any Betco authorized Service Distributor. If the original part is returned within the warranty policy period from date of delivery for inspection by Betco and is found to be defective the owner will be credited for the cost of replacement parts plus shipping and handling. Replacement parts that have become defective through wear or abuse are not included in this warranty.

This warranty does not apply to damage or defect caused by accident, misuse, Negligence, fire, or to any Betco product which has been serviced or repaired by other than an authorized Betco Service Distributor or Betco factory personnel. This warranty is void if products are used for any purpose other than that which was intended. There are no other warranties expressed or implied. In no event shall Betco be liable for incidental or consequential damages or any damage to person or property. (Please note some states do not allow the exclusion or limitations for incidental and consequential damages).

