



Electronic Service Manuals

This electronic document is provided as a service to our customers. We do not create the contents of the information contained in this document. Should you have detailed questions pertaining to the information contained in this document, you may contact Michco, or the manufacturer which provided the original information in this electronic deliverable. Michco's only part in this electronic deliverable was the electronic assembly process. By providing this manual on line we are not guaranteeing parts availability.

You may contact Michco through the following methods:

Phone (517) 484-9312 or (800) 331-3339

2011 N. High St. -- Lansing, Michigan -- 48906

Fax: (517) 484-9836

Email: CustServe@Michco.com

Web site: www.Michco.Com

Parts Web site: www.FloorMachineParts.Com

Order Parts on Line at:

www.FloorMachineParts.Com

Directly to Parts & Service:

By Email: **Shop@Michco.com**

By Fax: (517) 702-2041

By Voice: Use numbers above.

Serving the Cleaning Industry Since 1922

Notice: All copyrighted material remains property of original owners, all trademarks are property of respective owners. Manuals are subject to Manufacturer's reproduction limitations. Originals or reproductions were provided by manufacturers through a request. We make no warranty as to the correctness of information provided in this document and you assume all risk. By placing these manuals on line we are not declaring our corporation to be an manufacturer authorized dealer or provider, please check our web site for authorized manufacturers we represent.



E84700-00



MOTOMOP™

Small Area
Cleaning Machine



Operator and Parts
Manual

TABLE OF CONTENTS

RECEIVING THE MACHINE	3
TECHNICAL INFORMATION.....	4
GENERAL SAFETY INFORMATION	5
MACHINE PREPARATION	6 - 9
OPERATION	10
AFTER OPERATION	11
MAINTENANCE	12 - 14
DISPOSAL.....	15
MACHINE DIAGRAM AND PARTS LISTING	16 - 35
WARRANTY	36

RECEIVING THE MACHINE

Immediately check, when receiving the machine, that all the materials indicated on delivery documents have been received and also that the machine has not been damaged in transit. If it has been damaged, this damage must be immediately reported to the shipper and also to our customer's service department or a claim may not be made.

INTRODUCTION

This is an automatic scrubber which, via the mechanical action of the rotating brush and the chemical action of a water/detergent solution, cleans all types of hard flooring. As the scrubber advances, it also collects the dirt removed and the detergent solution not absorbed by the floor.

Only use this machine for its intended purpose. Please keep the machine in good working order by performing routine maintenance. Read this instruction manual and refer back to it when machine questions arise. Our technical customer service representatives should be contacted when machine questions are not answered by this manual.

Serial # Plate



SYMBOLS USED ON THE MACHINE



Main switch symbol:

Located on the rear part of the machine, to indicate the main switch.



Solenoid valve switch symbol:

Located on the rear part of the machine, to indicate the solenoid valve switch.



Symbol for squeegee movement to "work position":

Indicates the rotation direction of the squeegee control knob in order to bring the squeegee blades into contact with the floor.



Symbol for squeegee movement to "idle position":

Indicates the rotation direction of the squeegee control knob in order to raise the squeegee blades off the floor.



Lifting point symbol:

Indicates the location of the elements for lifting the machine or moving mobile machine parts.



"OPEN" symbol:

Located on the upper part of the machine, to indicate the position of the handle for opening the front cover.



Warning symbol not to rotate the machine:

Indicates that the machine must not be rotated when the tanks are full.

TECHNICAL DESCRIPTION	Measurement Unit	MotoMop™
Working width	in	13.5
Rear squeegee width	in	16
Work capacity	ft ² /hr	7,320
Battery	-	Lithium-ion
Run time	-	Up to 1 hour
Brush diameter	in	4.3
Brush motor	W	50
Drive type	-	Brush Assisted
Maximum grade	-	2%
Vacuum motor	W	100
Solution tank capacity	Gal	1/3 gallon
Recovery tank capacity	Gal	1/3 gallon
Weight of empty machine (without battery)	lbs	19.8
Weight of empty machine (with battery)	lbs	22.0
Machine dimensions upright (Length/Height/Width)	in x in x in	17.5 x 51.0 x 15.9
Machine dimensions stored (Length/Height/Width)	in x in x in	14.4 x 36.0 x 15.9



GENERAL SAFETY GUIDELINES

The guidelines below must be carefully followed in order to avoid harm to the operator and damage to the machine.

- Read the labels on the machine carefully. Do not cover the labels and replace them if they become damaged.
- The machine must be used only by authorized and trained personnel.
- When operating the machine do not endanger other people.
- The machine is not suitable for cleaning carpets.
- The charger power cord must be plugged into a grounded power outlet.
- Avoid damaging the power cable by not crushing, bending, cutting or stressing it.
- **WARNING:** Do not let the power cable come into contact with the rotating brush.
- Whenever the power cable is damaged, immediately contact a BETCO service center for a replacement power cord.
- Do not mix different types of detergent as they may produce harmful gases.
- Do not place objects on the machine.
- Machine storage temperature is between 33°F and 130°F, never store outside in humid conditions.
- Operating conditions: room temperature between 33°F and 100°F with relative humidity between 30% and 95%.
- Do not expose the machine to rain.
- Never use the machine in an explosive environment.
- Do not use the machine as a means of transportation.
- Never use acidic chemicals which could damage the machine.
- Avoid running the brushes with the machine stopped in one spot, as this could damage the floor.
- Never use the machine to vacuum up flammable liquids.
- Never use the machine to collect dangerous powders.
- Use a dry powder fire extinguisher in case of fire. Do not use water.
- Do not strike shelving or scaffolding.
- The operator must wear the appropriate Personal Protective Equipment (gloves, shoes, helmet, glasses, etc.)
- Do not use the machine on surfaces with an inclination greater than the one shown on the serial plate. The machine is designed to wash and dry floors simultaneously. Place caution signs in areas where wet floors are present.
- If the machine does not work properly, first perform routine maintenance. If further service is required, contact your dealer or contact BETCO technical service.
- When replacing parts, only use ORIGINAL replacement parts from your Authorized BETCO Dealer.
- Always turn off the machine and remove battery whenever maintenance is performed.
- Never remove guards that require tools to remove.
- Never wash the machine with direct or pressurized jets of water or with corrosive substances.
- Have your BETCO service center perform routine maintenance on the machine once a year.
- To prevent the formation of scale in the solution tank filter, clean tank with clear water after each use.
- Before using the machine, make sure that all covers are positioned as shown in this operating and maintenance manual.
- When your BETCO machine is ready to be disposed of, the machine must be disposed of properly. It contains oils and electronic components. The machine itself was built using totally recyclable materials.
- Use only brushes furnished with the machine or those specified in the user's manual. Use of other brushes can compromise safety.
- This machine must be operated by trained professionals.



IMPORTANT: The machine must not be transported or parked in its idle position when the solution tank and recovery tank have fluids in the tanks.

MACHINE PREPARATION

1. HANDLING THE PACKED MACHINE

Total weight is 40 lbs. per box.

Overall dimensions are:

A: 10.6 in (270 mm)

B: 19.2 in (487 mm)

C: 27.5 in (698 mm)

2. HOW TO UNPACK THE MACHINE

1. Place the lower part of the outer packaging in contact with the floor.
2. Open the outer box.
3. Remove the accessories from the box and carefully lay them on the ground.
4. Take the MotoMop out of the box.

3. MACHINE ASSEMBLY

1. Take the package to the maintenance department.
2. Remove the MotoMop and all the accessories from the box.
3. Insert the lower tube (1) of the control handle into the hole on the joint (2) (Fig.1).
4. Attach the handle to the joint using the screw and nut (3), making sure the hole in the handle aligns with the hole on the joint (Fig.2).
5. Lock the handle in the horizontal position. Rest your foot on the main part of the machine to prevent it from tilting, then push the handle away from you until it snaps into the horizontal position (Fig.3).
6. Rotate the stop lever of the handle (4) in the direction of the arrow (Fig.4).
7. Collapse the handle by pushing the handle (5) towards the main body of the machine (Fig.5).
8. Rotate the lock lever of the handle (4) in the direction of the arrow (Fig.6).

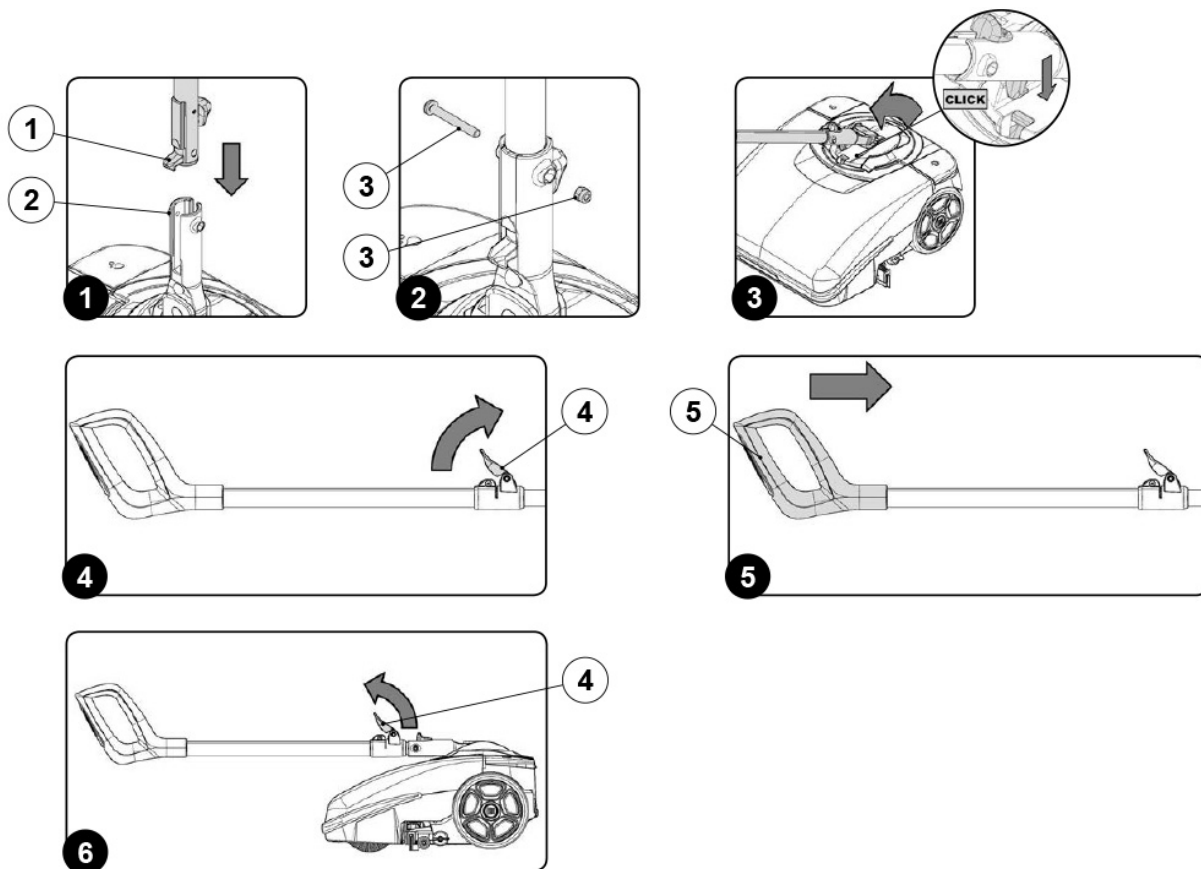

MACHINE PREPARATION

4. HANDLING AND TRANSPORTATION OF THE UNPACKED MACHINE

The procedure for the safe handling of the machine is the following:

1. If the machine is in operation, turn it off via the main switch (1) (Fig.1).
2. Empty the recovery tank.
3. Empty the solution tank.
4. Remove the battery (2) from the machine. To remove the battery, slide the stop lever (3) in the direction of the arrow (Fig.2).
5. Remove the battery from the machine using the handle molded into it (Fig.3).
6. Lock the handle in the horizontal position. Rest your foot on the main part of the machine to prevent it from tilting, then push the handle away from you until it snaps into the horizontal position (Fig.4).
7. Rotate the stop lever of the handle (4) in the direction of the arrow (Fig.5).
8. Collapse the handle by pushing the handle (5) towards the main part of the machine (Fig.6).
9. Rotate the lock lever of the handle (4) in the direction of the arrow (Fig.7).
10. To raise the device off the floor, use the handle (6) at the back of the machine (Fig.8).

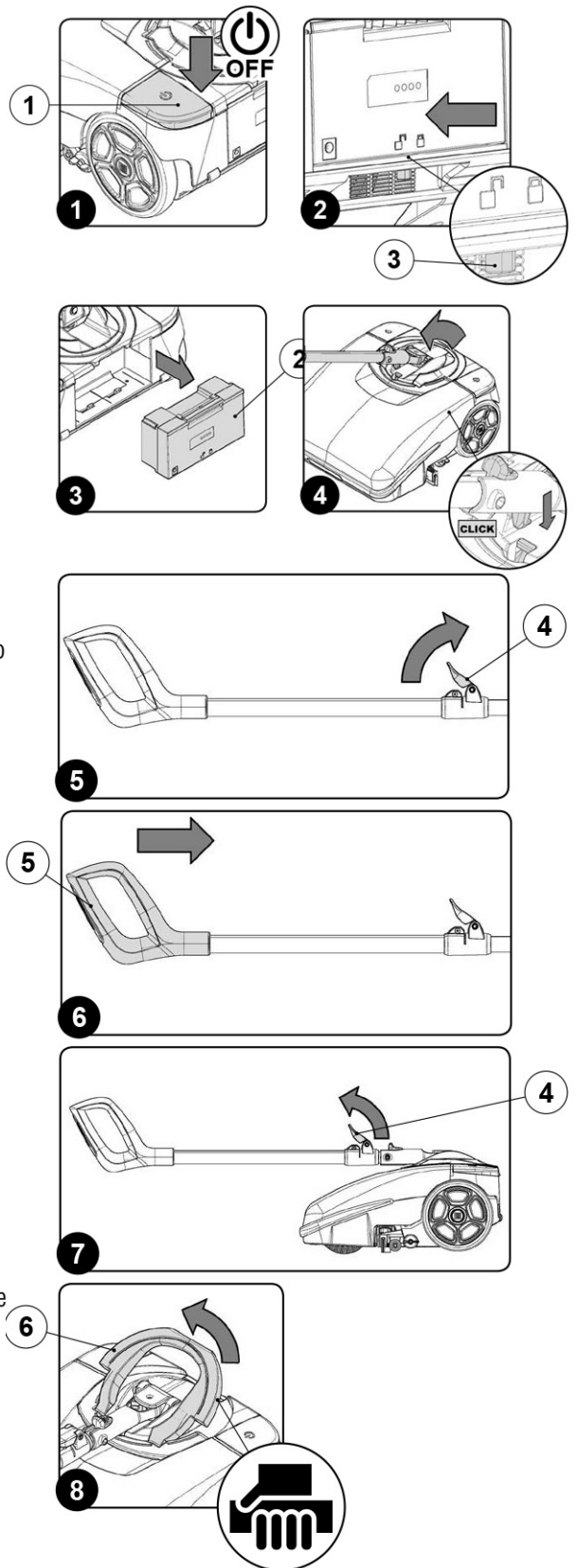

MACHINE PREPARATION

5. CHARGING THE BATTERY

The battery must be charged prior to the first use, and when it is discharged from use. To recharge the battery, proceed as follows:

1. Take the machine to its battery recharging area.
2. If the machine is working, turn it off via the main switch (1) (Fig. 1).
3. Lock the handle in the vertical position.
4. Read the battery charger manual (supplied with the device) before inserting the power plug (2) in the power supply unit (3) (Fig.2).
5. Plug the power plug (2) into an appropriate electrical outlet.
6. Remove the cap (5) covering the battery power socket (Fig.4).
7. Insert the battery charger power cable plug (6) in the socket (7) on the battery (Fig.5).
8. Perform a complete battery charging cycle.
9. Once the charging cycle is completed, remove the plug (2) on the battery charger from its electrical power outlet.
10. Take the power cable plug (6) out of the socket (7) on the battery.
11. Insert the cap (5) that covers the battery power socket.

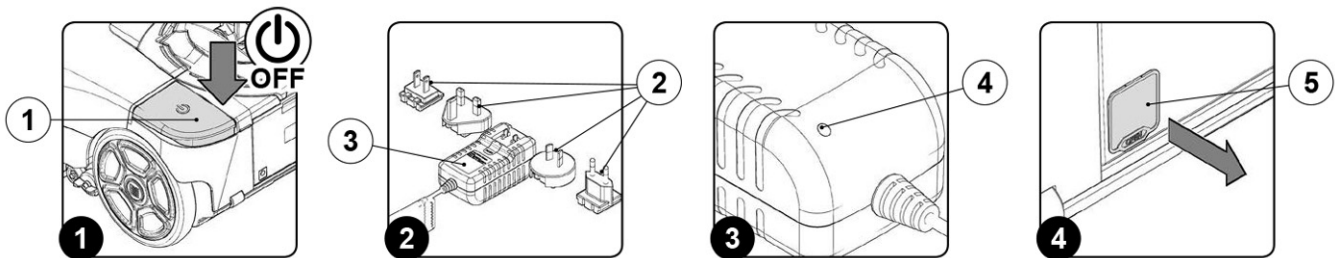

ATTENTION: the room where the batteries are recharged must be adequately ventilated to prevent the accumulation of gases that leak from batteries.

ATTENTION: before inserting the plug (6) in the socket (7), make sure the battery charger housing compartment is not dirty (dust, condensation or other types of liquid).

ATTENTION: the red LED (4) remains on until the battery is fully charged. When the recharging cycle has ended, the red LED goes off and the green LED comes on.

ATTENTION: The charger and the battery can be left connected to the power outlet. The red LED (4) lights up when the charger occasionally tops up the battery.

ATTENTION: make sure the green LED (4) on the battery charger lights up when you enable the battery charger base circuit (Fig.3). This LED indicates that the battery charger circuit is correctly powered.

ATTENTION: to prevent any damage to the mains socket, pull directly on the plug (not on the cable) when taking it out.

ATTENTION: during the charging phase, the battery may overheat. This is normal and does not mean there is any problem with the battery.

ATTENTION: if the battery used in this machine is overcharged, there may be a risk of fire, explosion or chemical burns.

6. CONNECTING THE BATTERY

Insert the battery (6) in the battery compartment (7) in the rear part of the machine (Fig.7). Push the battery until the uncoupling lever (8) locks into place.

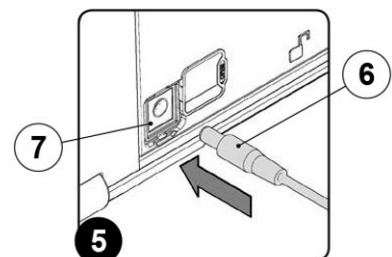

MACHINE PREPARATION

7. BATTERY MAINTENANCE AND DISPOSAL

To power the MotoMop, use only the battery supplied in the package or supplied by a Betco authorized service provider. OTHER BATTERY TYPES CANNOT BE USED.

The MotoMop is powered by a lithium-ion battery. The battery compartment can accommodate a single battery slot at 25.55V.

 **ATTENTION:** for the maintenance and disposal of the battery, refer to the document supplied by the battery manufacturer.

8. PREPARING FOR WORK CYCLE

Before beginning to work, it is necessary to:

1. Before using the machine, make sure it is in a good, safe working condition. If there are items that are not in order, the machine must not be used.
2. Position the handle so it is vertical.
3. Activate the machine using the main switch (1) (Fig.1).
4. Check the battery charge level. There are four LEDs (2) on the battery to show the charge percentage (Fig.2). If all the LEDs are lit up, the battery is fully charged; if they are all switched off, the battery is completely discharged.
5. Turnoff the machine using the main switch (1) (Fig.3).
6. Remove the battery (3) from the machine. To free the battery, slide the lock lever (4) in the direction of the arrow (Fig.4).
7. Remove the battery from the machine using the molded handle (Fig.5).
8. Make sure the condition of the squeegee blades are suitable for the work you want to perform. If they are damaged, perform the necessary maintenance (read "MAINTENANCE").
9. Make sure the condition of the brush is suitable for the work you want to perform. If it worn, perform the necessary maintenance (read "MAINTENANCE").
10. Rotate the front cover (5) as far as it will go - do this with the aid of handle (6) (Fig.6).
11. Remove the solution tank from the device (Fig.7). Carefully place it on the floor.
12. Remove the detergent solution filling cap (7) from its seat on the solution tank (Fig.8).
13. Fill with clean water, at a temperature no higher than 120° F and no lower than 50° F.
14. Add the liquid detergent to the solution tank in the concentration and manner indicated on the detergent manufacturer's label.
15. Replace the detergent solution filling cap (7) in its seat on the solution tank (Fig.9).
16. Insert the solution tank in the device (Fig.10).
17. Rotate the front cover (5) as far as the work position - do this with the aid of the handle (6) (Fig.11).
18. Insert the battery in the battery compartment in the rear part of the device.

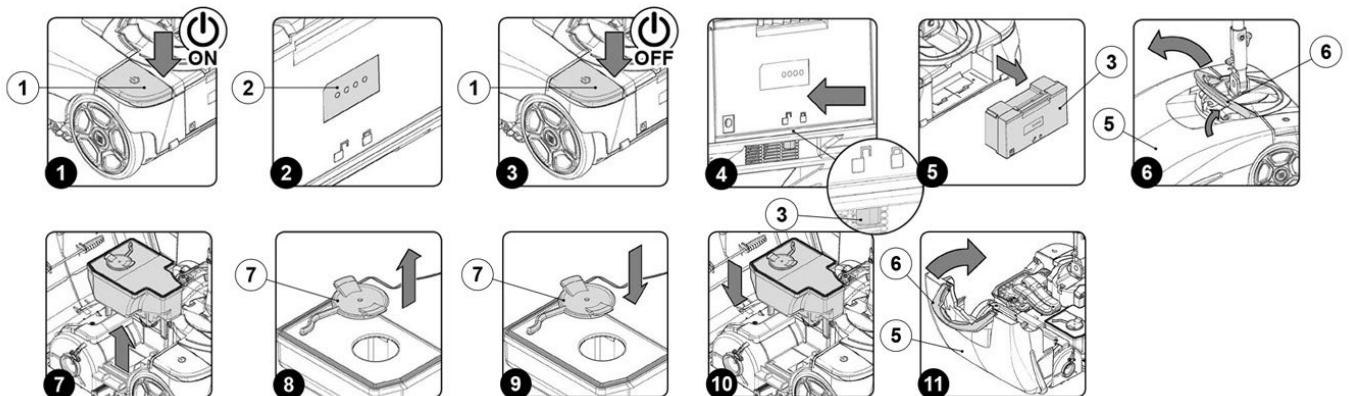



 **ATTENTION:** before beginning the first work cycle, fully recharge the battery (read "RECHARGING THE BATTERY").

 **ATTENTION:** these operations must be carried out using protective gloves to avoid any possible contact with the edges or tips of metal objects.

 **ATTENTION:** Always use detergents whose manufacturer's label indicates their suitability for scrubbing machines. Do not use acid or alkaline products or solvents without this indication. Acid or alkaline maintenance detergents can be used, as long as they have pH values between four and ten, and do not contain oxidising agents, chlorine or bromine, formaldehyde, mineral solvents.

 **ATTENTION:** if the LED of the main switch (1) (Fig.1) is lit up, this means the electrical system of the machine is activated.

 **ATTENTION:** The formation of excess foam could damage the vacuum motor, so use only the minimum amount of detergent that is necessary.

 **ATTENTION:** it is good practice to empty the recovery tank every time you top up the solution tank level.

 **ATTENTION:** always use low-foam detergent. To avoid the production of foam, put a small amount of defoamer liquid in the recovery tank before starting to clean. Do not use pure acids.

 **ATTENTION:** protective gloves should always be worn before handling detergents or acidic or alkaline solutions, to avoid serious injury to the hands.

OPERATION

1. Carry out the operations described in the “PREPARING TO WORK” chapter.
2. Check that the squeegee body is in contact with the surface to be cleaned. If it isn't, turn the knob (1) in the direction of the arrow (Fig.1).
3. Release the handle from its vertical position and rotate it towards you.
4. Adjust the length of the handle.
5. Activate the machine using the main switch (2) (Fig.2).
6. Activate the detergent solution supply by pressing the electric pump control switch (3) (Fig.3).
7. The machine will now begin to work until the battery is discharged or until the detergent solution runs out.

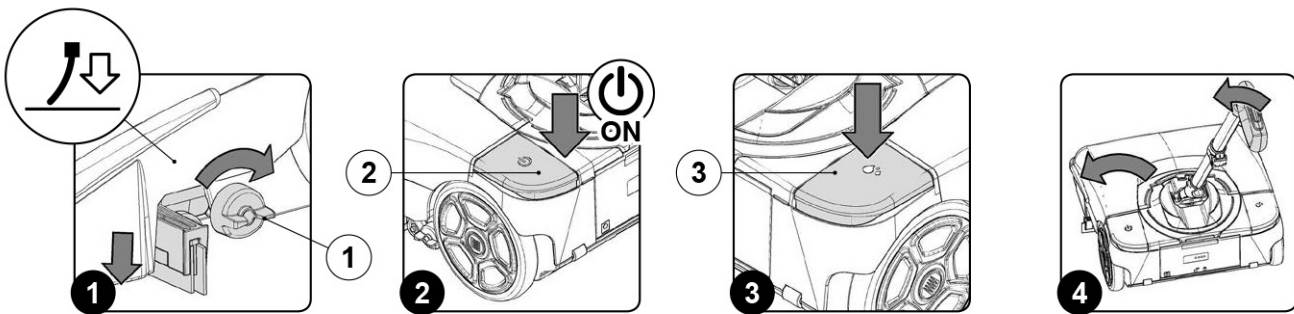

ATTENTION: Fig.1 shows the left side of the device. Rotate the knob on the right-hand side in the opposite direction.

ATTENTION: During this operation, do not rest your foot on the machine.

ATTENTION: if the LED of the main switch (2) (Fig.2) is lit up, this means the electrical system of the machine is activated.

ATTENTION: as soon as the device has been activated, the front LEDs will light up and both the brush motor and the vacuum motor will start working.

ATTENTION: if the LED of the electric pump control switch (3) (Fig.3) is active, this means the pump will supply detergent solution.

ATTENTION: the joint on the device guarantees greater manageability. To make a left-hand turn, rotate the handle to the left (Fig.4); rotate it to the right when you want to turn right.

ATTENTION: if you need to turn back while you are working, just rotate the device by 180° by rotating the handle.

ATTENTION: if the handle is placed in the idle position (vertical) during use, the brush motor and electric pump will stop working. After a few seconds, the vacuum motor will switch off as well.

ATTENTION: when the battery charge levels reach a certain value during use, the brush motor and the electric pump will stop working. After a few seconds, the vacuum motor will switch off automatically as well. Both the LED of the main switch and that of the electric pump control switch will remain ON.

AFTER OPERATION

1. Turn off the machine using the main switch (1) (Fig.1).
2. Rotate the handle so it is vertical.
3. Raise the squeegee off the floor and rotate the knob (2) in the direction of the arrow (Fig.2).
4. Take the machine to the waste water drainage area.
5. Remove the battery (3) from the machine. To free the battery, slide the stop lever (4) in the direction of the arrow (Fig.3).
6. Remove the battery from the machine using the handle molded into it (Fig.4).
7. Rotate the front cover (5) as far as it will go - do this with the aid of the handle (6) (Fig.5).

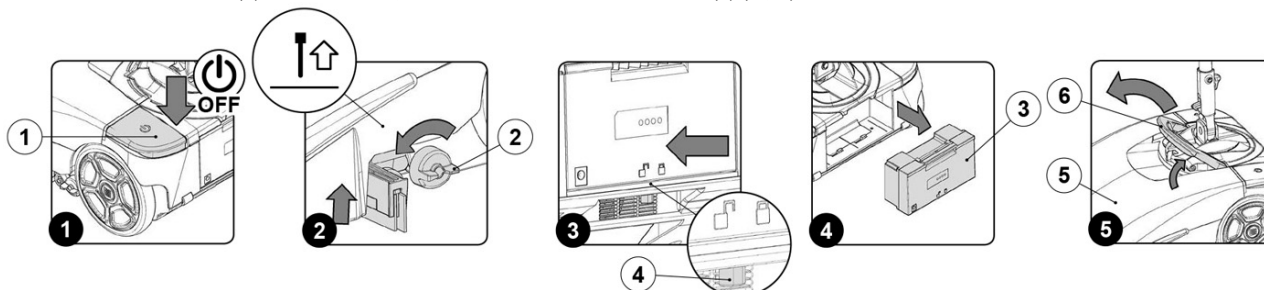

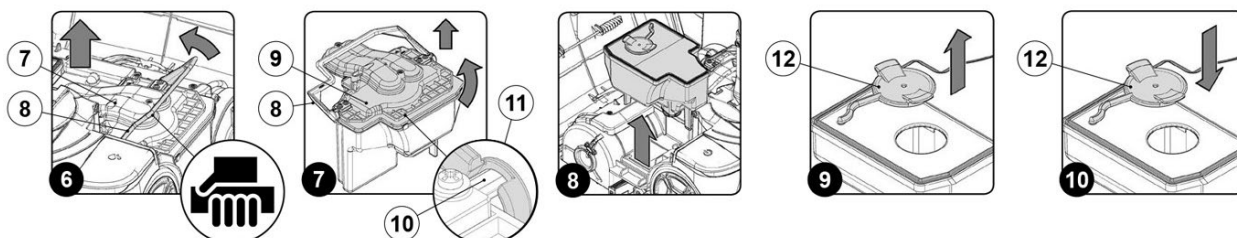

8. Remove the recovery tank (7) from the machine - do this with the aid of the handle (8) (Fig.6).
9. Remove the recovery tank cover (9), then rotate the handle (8) completely to free the pin (10) from the clamp (11) (Fig.7).
10. Empty the tank.
11. Rinse the inside of the tank with clear water.
12. Position the recovery tank cover (9) on the tank.
13. Fix the cover on the tank, then rotate the handle (8) completely to locking pin (10) on the clamp (11).
14. Remove the solution tank from the device (Fig.8).
15. Remove the detergent solution filling cap (12) from its seat on the solution tank (Fig.9).
16. Empty the tank.
17. Rinse the inside of the tank with clear water.
18. Replace the detergent solution filling cap (12) in its seat on the solution tank (Fig.10)



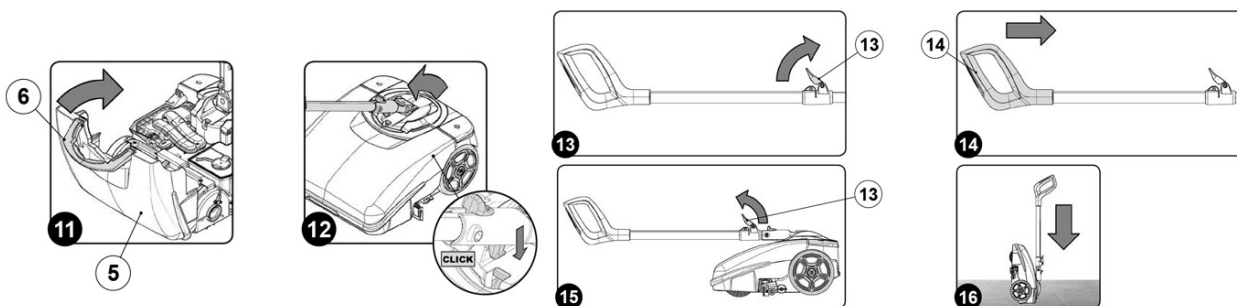

19. Insert the two tanks in the machine, positioning first the solution tank and then the recovery tank.
20. Rotate the front cover (5) as far as the work position - do this with the aid of the handle (6) (Fig.11).
21. Lock the handle in the horizontal position (Fig.12).
22. Rotate the stop lever of the handle (13) in the direction of the arrow (Fig.13).
23. Collapse the handle by pushing the handle (14) towards the main part of the machine (Fig.14).
24. Rotate the stop lever of the handle (13) in the direction of the arrow (Fig.15).
25. Take the machine to its storage area.
26. Position the machine with its rear part in contact with the floor (Fig.16).





 **ATTENTION:** During this operation, do not rest your foot on the machine.

 **ATTENTION:** The place this operation is carried out should comply with current environmental protection regulations.

 **ATTENTION:** these operations must be carried out using protective gloves to avoid any possible contact with the edges or tips of metal objects.

 **ATTENTION:** Fig.2 shows the left side of the device. Rotate the knob on the right-hand side in the opposite direction.

 **ATTENTION:** protective gloves should always be worn before handling detergents or acidic or alkaline solutions, to avoid serious injury to the hands.

 **ATTENTION:** Park the machine in an enclosed place, on a flat surface; near the machine there must be no objects that could either damage it, or be damaged through contact with it.

MAINTENANCE

1. Turn off the machine using the main switch (1) (Fig.1).
2. Rotate the handle so it is vertical.
3. Remove the battery (2) from the machine. To remove the battery, slide the stop lever (3) in the direction of the arrow (Fig.2).
4. Remove the battery from the machine using the handle molded into (Fig.3).
5. Rotate the front cover (4) as far as it will go - do this with the aid of the handle (5) (Fig.4).
6. Remove the brush housing cover (6) and slide the stop levers (7) as indicated by the arrows (Fig.5).

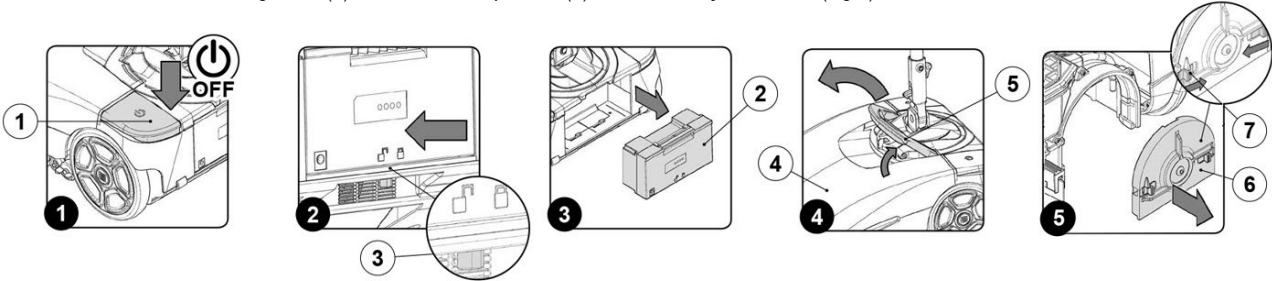

7. Remove the brush (8) from the machine (Fig.6).
8. Clean the brush under running water to remove any impurities present in the bristles. Check that the bristles are not worn; in the event of excessive wear, replace the brush (the bristles should be at least 10 mm long).
9. Fit the brush (8) on the pin in the brush motor (the brush can only be inserted in one direction) (Fig.7).
10. Replace the brush housing cover (6) and slide the stop levers (7) as indicated by the arrows (Fig.8)
11. Remove the recovery tank (9) from the machine - do this with the aid of the handle (10) (Fig.9).
12. Remove the recovery tank cover (11), then rotate the handle (10) completely to free the pin (12) from the clamp (13) (Fig.10).

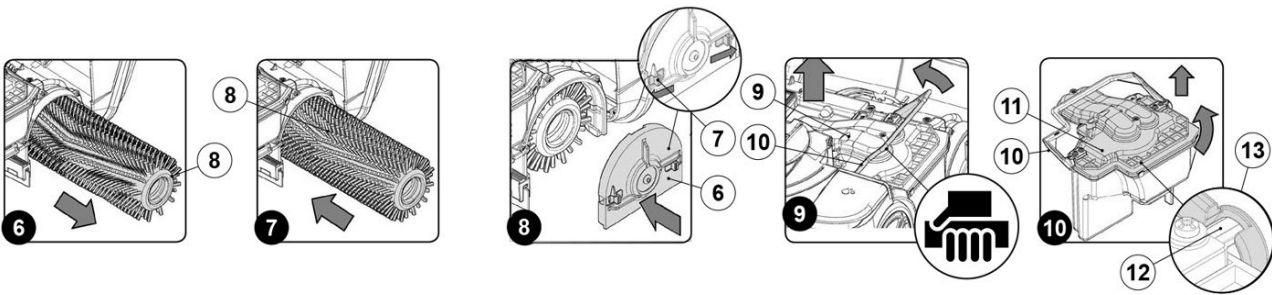

13. Use a clear water and then a damp cloth to thoroughly clean the rotation pivot (14) of the vacuum motor floats (Fig.11).
14. Use clear water and then a damp cloth to thoroughly clean the central float (15) (Fig.12).
15. Clean the recovery tank with clear water; the entrance hole to this compartment is identified by the letter (A), while the outlet is identified with the letter (B) (Fig. 13).
16. Clean the vacuum motor air conveyor compartment with air; the entrance hole to this compartment is identified by the letter (C), while the outlet is identified with the letter (D) (Fig. 14).
17. Replace the cover on the recovery tank, then rotate the handle (10) completely to lock the pin (12) on the clamp (13).
18. Remove the solution tank from the machine (Fig.15).
19. Remove the filter cartridge (17) and clean it with clear water to remove any impurities that might be attached. If necessary, replace it (Fig.16).
20. Remove the vacuum duct cleaning brush (18) from its support (Fig.17).
21. Clean the inside of the vacuum duct (19) with the brush (18) (Fig.18).
22. Replace the vacuum duct cleaning brush (18) in its support (Fig.19).
23. Rotate the front cover (4) as far as the work position - do this with the aid of the handle (5) (Fig.20).
24. Lock the handlebar in the horizontal position (Fig.21).

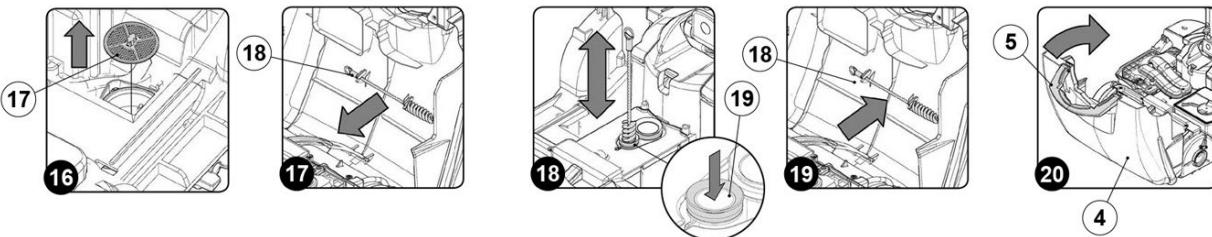

MAINTENANCE

25. Rotate the stop lever of the handle (20) in the direction of the arrow (Fig.22).
26. Collapse the handle, pushing the handle (21) towards the main part of the machine (Fig.23).
27. Rotate the clamp lever of the handle (20) in the direction of the arrow (Fig.24).
28. Position the machine with its rear part in contact with the floor (Fig.25).
29. Make sure the squeegee is in the work position. To do this rotate the knob (22) in the direction of the arrow (Fig.26).

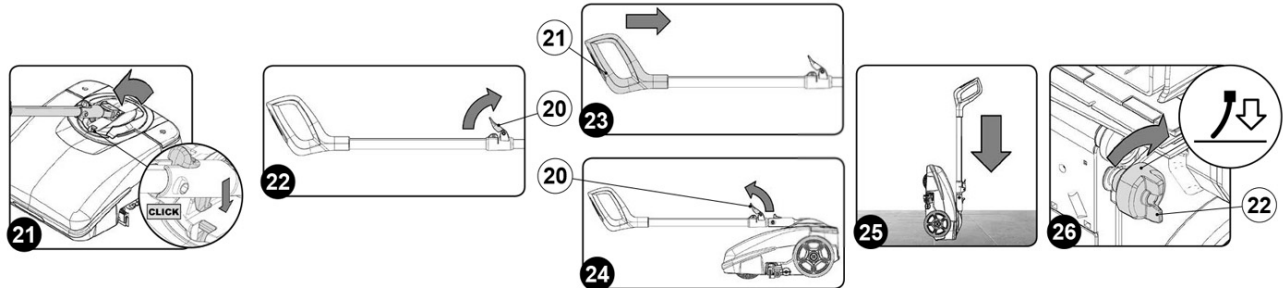

30. Use a damp cloth to thoroughly clean the vacuum nozzle duct (23) (Fig.29).
31. Use a damp cloth to thoroughly clean the vacuum chamber of the squeegee (25) (Fig.30).
32. Use a damp cloth to thoroughly clean the front blade (26) of the squeegee (Fig.31). Check the condition of the front blade; if the edge that is in contact with the floor is worn, replace it.
33. Use a damp cloth to thoroughly clean the rear blade (27) of the squeegee (Fig.32). Check the condition of the rear blade; if the edge that is in contact with the floor is worn, replace it.

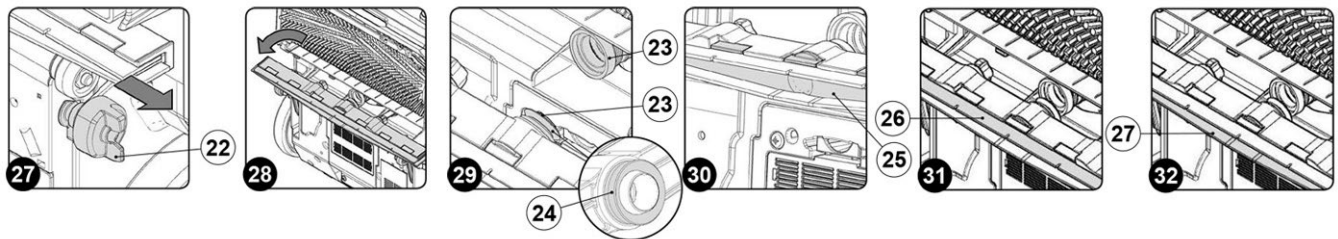

Careful maintenance of the squeegee blades guarantees better cleaning and drying of the floor, as well as a longer vacuum motor life. To replace the squeegee blades, proceed as follows:
Turn the wing nuts (28) that hold the squeegee by 90° (Fig.33). Remove the squeegee from the slots on the squeegee connector, taking care not to lose the seal on the vacuum nozzle (Fig.34).

Replace the worn/damaged blades.

Repeat the operations in reverse order to reassemble all the parts.

34. Bring the squeegee coupling to the idle position and shift the squeegee towards the machine (Fig.35).
35. Lock the squeegee coupling in the idle position. Push the knob (22) towards the machine (Fig.36), then rotate it in the direction of the arrow (Fig.38).
36. Remove the exhaust air filter support (29) from the machine by pressing the locking tab (30) in the direction of the arrow (Fig.38).
37. Clean the filter cartridges (31) with a jet of air (Fig.39), from a distance of at least 8 inches.

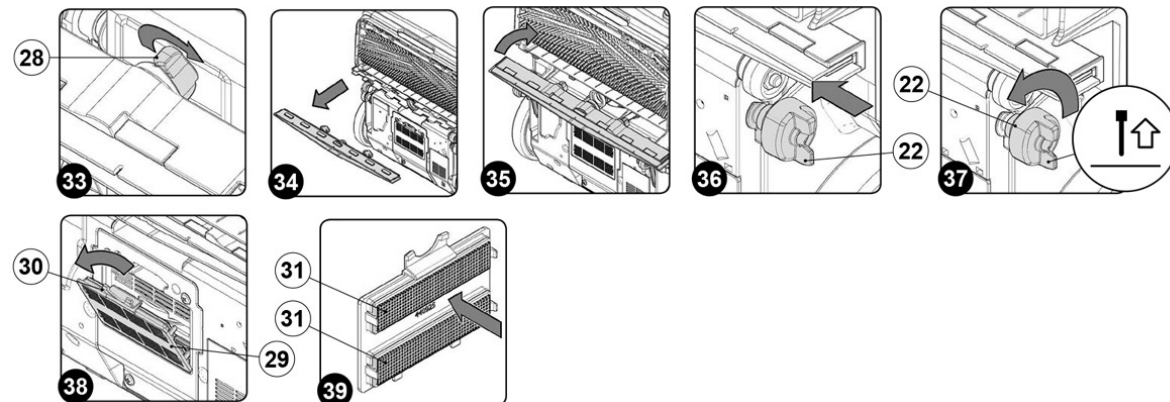

MAINTENANCE

Remove the filter cartridge supports (32) from the filter support (Fig.40).

Remove the worn filter cartridge (31) from the filter cartridge support (32) and replace it with the new one (Fig.41). Repeat the operations in reverse order to reassemble all the parts.

38. Insert the exhaust air filter support (29) in the machine (Fig.42).

39. Rotate the machine to its work position (Fig.43).

40. Lock the handle in the vertical position; to release the handle, move the stop (33) in the direction of the arrow (Fig.44).

41. Rotate the front cover (4) as far as it will go - do this with the aid of the handle (5) (Fig.45).

42. Insert the two tanks and the detergent solution filter cartridge in the machine, positioning first the detergent solution filter cartridge, then the solution tank, and finally the recovery tank.

43. Rotate the front cover (4) as far as the work position - do this with the aid of the handle (5) (Fig.46).

44. Insert the battery in the battery compartment in the rear part of the machine (Fig.47).

45. Position the machine with its rear part in contact with the floor (Fig.48).

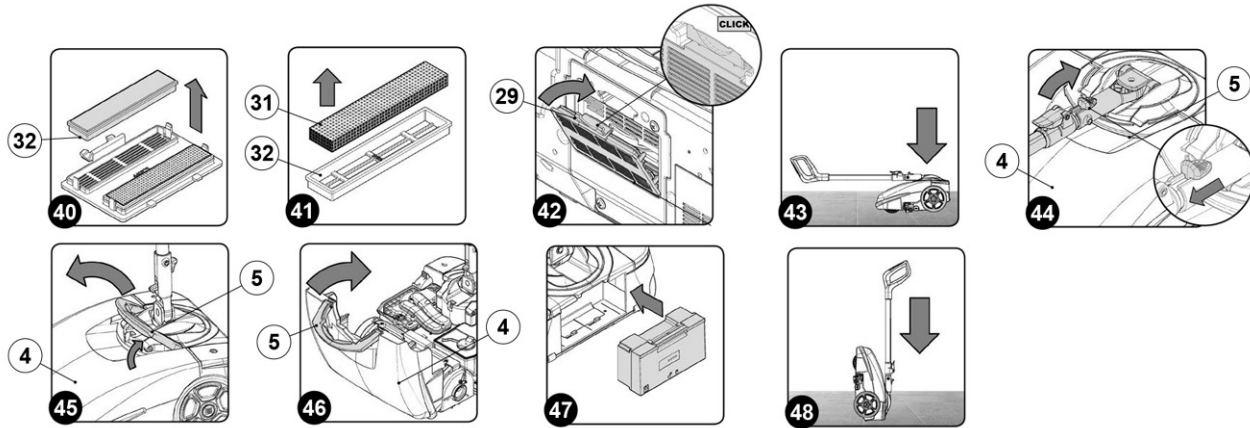

ATTENTION: During this operation, do not rest your foot on the machine.



ATTENTION: these operations must be carried out using protective gloves to avoid any possible contact with the edges or tips of metal objects.



ATTENTION: During this operation, do not rest your foot on the machine.



ATTENTION: carry out this operation for both the left-hand knob and the right-hand knob.



ATTENTION: Fig.37 shows the left side of the device. Rotate the knob on the right-hand side in the opposite direction.



ATTENTION: The place this operation is carried out should comply with current environmental protection regulations.



ATTENTION: during this process, keep the handle still, in order to prevent the machine from moving accidentally.



ATTENTION: Fig.26 shows the left side of the device. Rotate the knob on the right-hand side as well.



ATTENTION: be careful not to lose or damage the seal (24) above the vacuum nozzle (Fig.29).



ATTENTION: Park the machine in an enclosed place, on a flat surface.

DISPOSAL

To dispose of the machine, take it to a re-cycling center or an authorized collection center. Before scrapping the machine, it is necessary to remove and separate out the following materials, then send them to the appropriate collection centers in accordance with applicable environmental regulations:

- Brush
- Electric and electronic parts*
- Battery
- Plastic parts
- Metallic parts

(*) In particular, contact your distributor when scrapping electric and electronic parts.



DIAGRAM 1

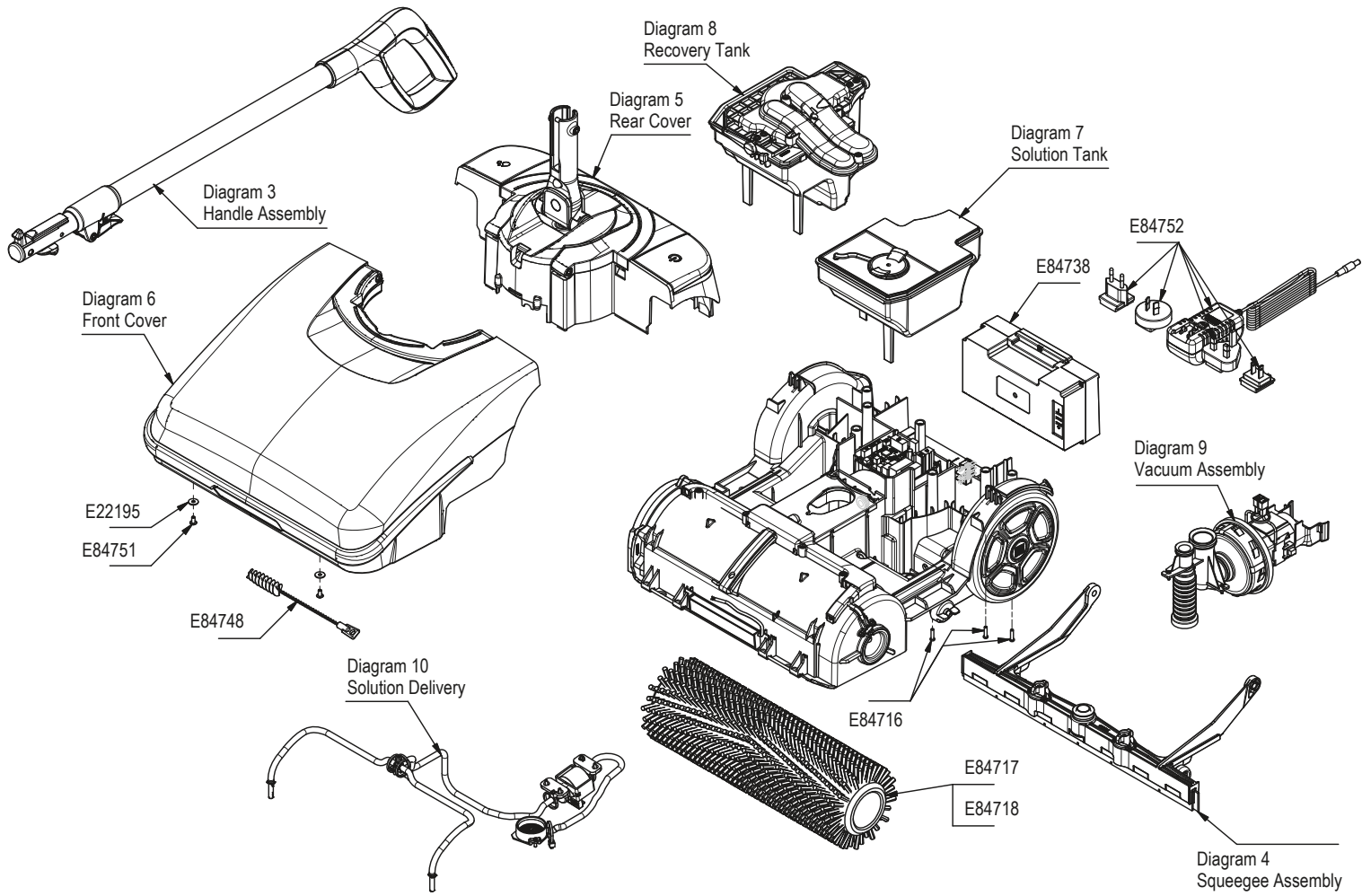

DIAGRAM 1 PARTS LISTING

Part #	Description	Qty.
E84738	LITHIUM ION BATTERY	1
E84717	CYLINDRICAL BRUSH, BLUE, PPL 0.3	1
E84718	CYLINDRICAL BRUSH, BLACK, PPL 0.2	1
E84748	MAINTENANCE BRUSH	1

Part #	Description	Qty.
E84752	BATTERY CHARGER	1
E22195	WASHER, FLAT M4 X 12 X 1	2
E84716	SCREW, PAN HEAD, PHIL SELF TAPPING M3.5 X 14 MM LG SS	8
E84751	SCREW, PAN HEAD, PHIL SELF TAPPING M4 X 8 MM LG SS	2

DIAGRAM 2 MAIN BODY

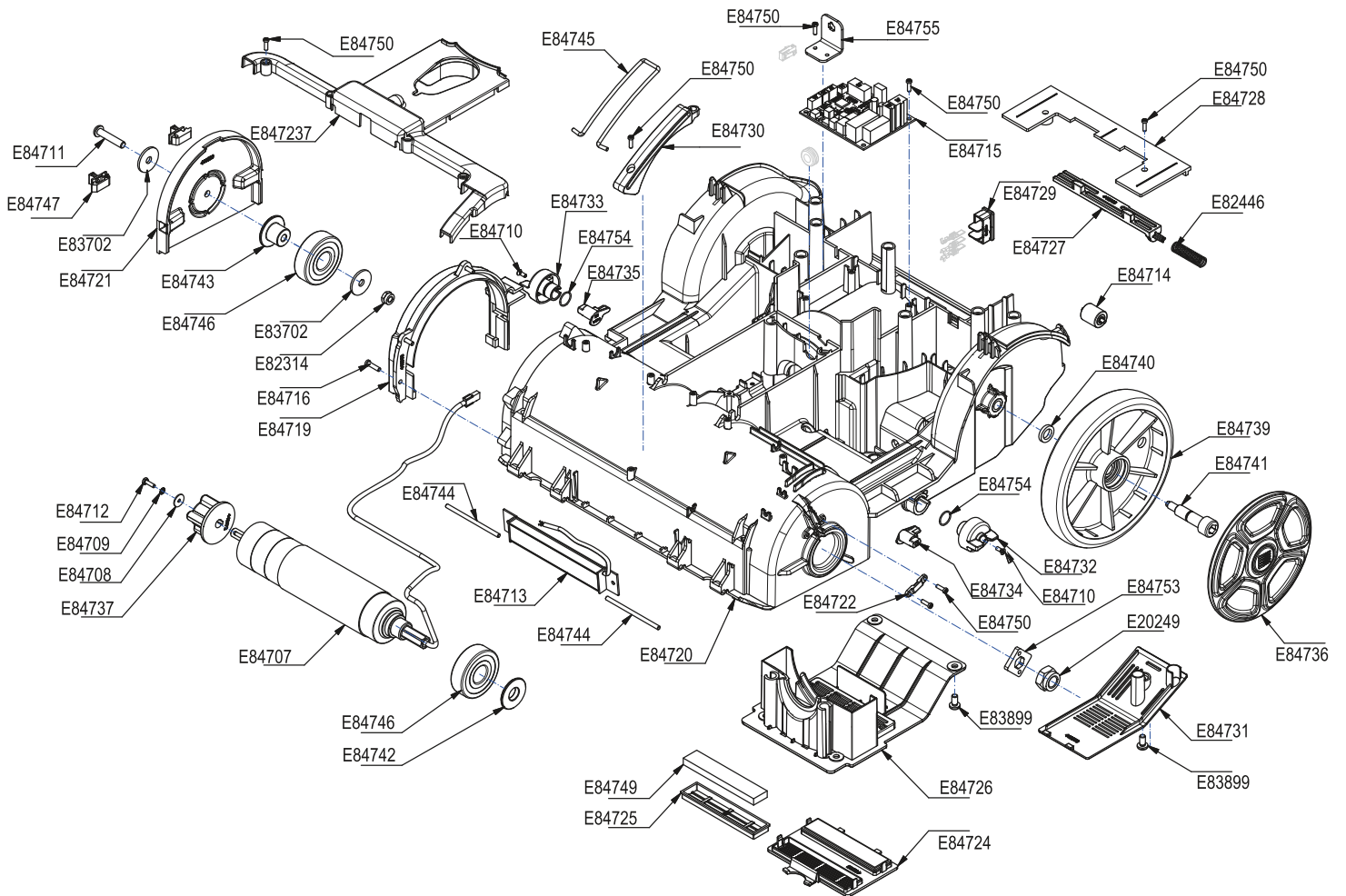

DIAGRAM 2 PARTS LISTING

Part #	Description	Qty.
E84706	BRUSH COVER ASSEMBLY	1
E83702	WASHER, FENDER M6 X 24 MM X 2 MM	2
E84711	SCREW, SOCKET BUTTON HEAD M6 X 30 MM LG	1
E82314	NUT, HEX NYLOC M6	1
E84721	HUB COVER	1
E84743	BUSHING	1
E84746	BEARING	2
E84747	COVER LOCK	2
E84707	BRUSH MOTOR, 24V 32W 375RPM	1
E82446	SPRING	1
E83899	SCREW, PAN HEAD PHIL M5 X 10 MM LG	5
E84708	WASHER, FENDER, M3 X 12 X 0.8	1
E84709	WASHER, SERRATED LOCK	1
E84710	SCREW, FLAT HEAD PHIL M3 X 8 MM LG	2
E84712	BOLT, HEX M3 X 12 MM LG	1
E20249	NUT, HEX NYLOC M12	1
E84713	LED HEAD LIGHT	1
E84714	SMALL REAR WHEEL	2
E84715	CONTROLLER CARD	1
E84716	SCREW, PAN HEAD, PHIL SELF TAPPING M3.5 X 14 MM LG	4
E84719	BRUSH COVER REINFORCEMENT	1
E84720	LOWER BODY FRAME	1
E84722	CLAMP	1
E84723	ROUTING COVER	1
E84724	VACUUM MOTOR FILTER COVER	1

Part #	Description	Qty.
E84725	FILTER HOLDER	2
E84726	VACUUM MOTOR COVER	1
E84727	BATTERY RELEASE LEVER	1
E84728	BATTERY BOX LOWER COVER	1
E84729	BATTERY ELECTRICAL CONTACTS	1
E84730	COVER SUPPORT GUIDE	1
E84731	WATER PUMP COVER	1
E84732	SQUEEGEE POSITION KNOB LEFT	1
E84733	SQUEEGEE POSITION KNOB RIGHT	1
E84734	SQUEEGEE POSITION LEVER LEFT	1
E84735	SQUEEGEE POSITION LEVER RIGHT	1
E84736	WHEEL COVER	2
E84737	BRUSH DRIVER	1
E84739	MAIN WHEEL	2
E84740	WHEEL SPACER	2
E84741	WHEEL AXLE	2
E84742	BUSHING	1
E84744	COVER PIVOT PIN	2
E84745	COVER SUPPORT	1
E84749	VACUUM MOTOR FILTER	2
E84750	SCREW, PAN HEAD, PHIL SELF TAPPING M3 X 10 MM LG	15
E84753	MOTOR WASHER	1
E84754	O-RING	2
E84755	SUPPORT BRACKET	1

DIAGRAM 3 HANDLE ASSEMBLY

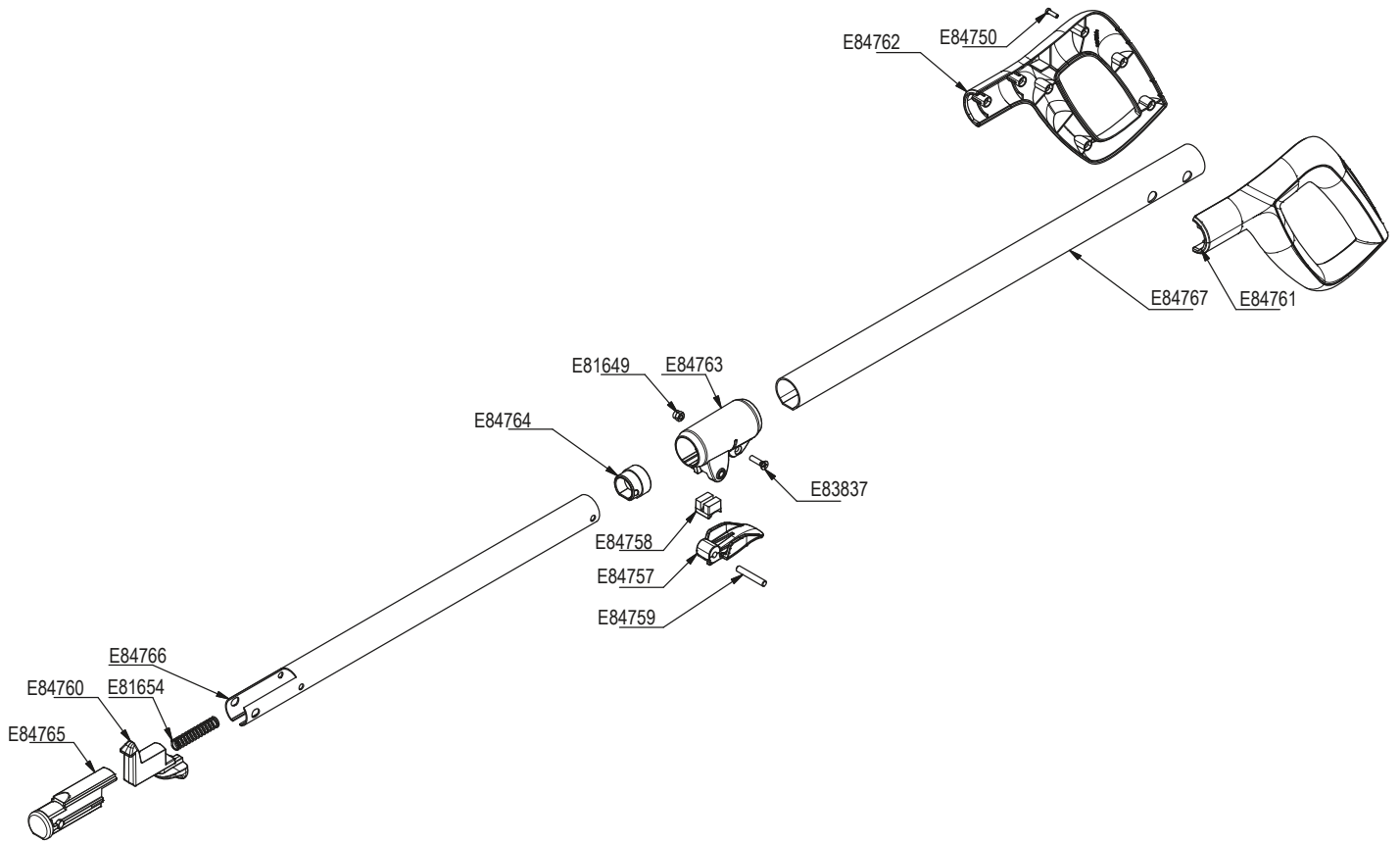

DIAGRAM 3 PARTS LISTING

Part #	Description	Qty.	Part #	Description	Qty.
E84756	LOCKING JOINT ASSEMBLY	1	E84760	LOWER LOCKING LEVER	1
E83837	SCREW, FLAT HEAD, PHIL M4 X 16 MM LG	1	E84761	LEFT HANDLE SIDE	1
E81649	NUT, HEX NYLOC M4	1	E84762	RIGHT HANDLE SIDE	1
E84757	LOCKING HANDLE LEVER	1	E84764	TELESCOPING RESTRICTION CAP	1
E84758	LOCKING SLIDE	1	E84765	LOWER LOCK RETENTION CAP	1
E84759	HANDLE PIVOT PIN	1	E84766	LOWER TELESCOPING HANDLE TUBE	1
E84763	LOCKING JOINT BODY	1	E84767	UPPER TELESCOPING HANDLE TUBE	1
E81654	SPRING	1	E84750	SCREW, PAN HEAD, PHIL SELF TAPPING M3 X 10 MM LG	7

DIAGRAM 4 SQUEEGEE ASSEMBLY

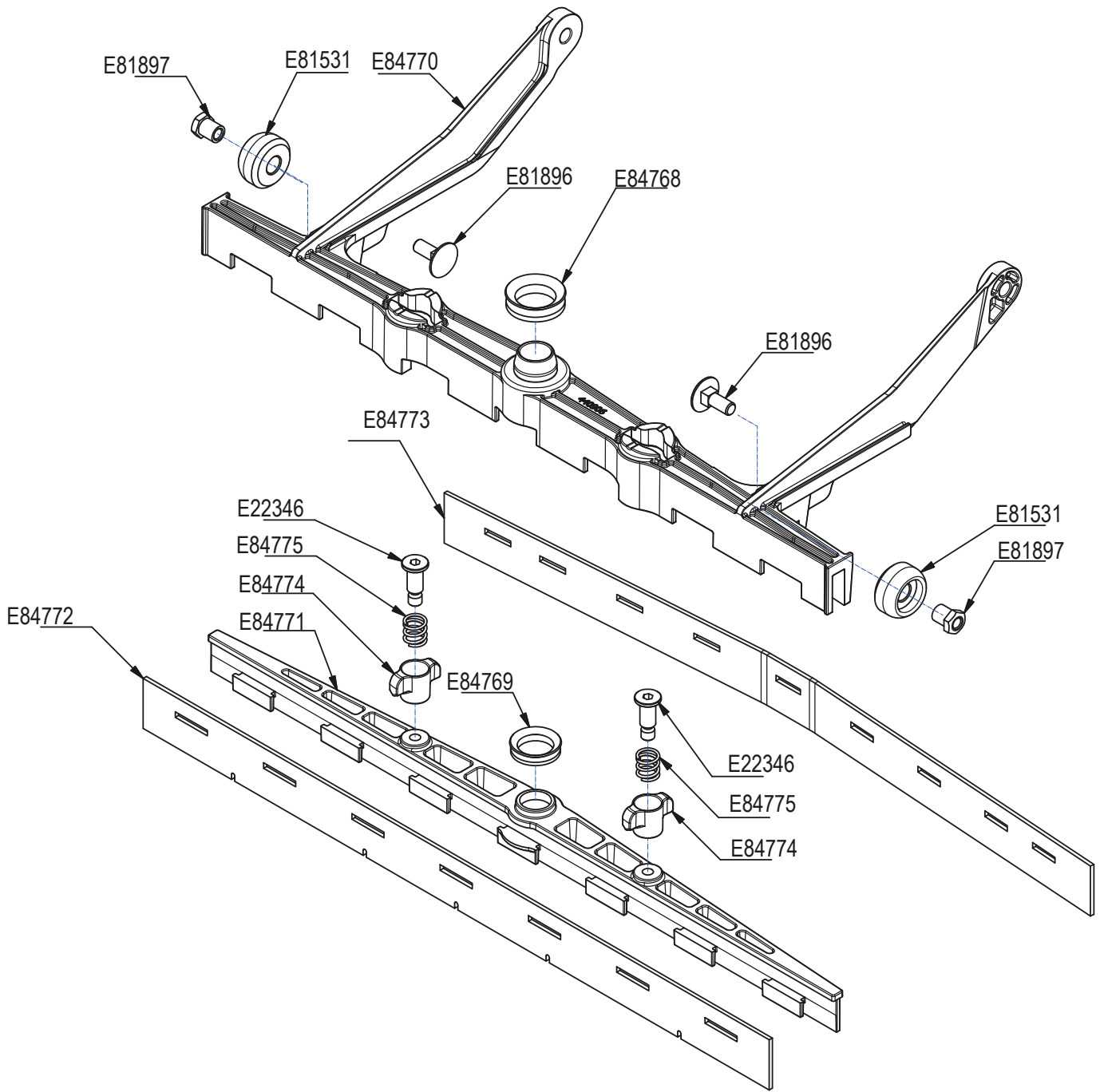

DIAGRAM 4 PARTS LISTING

Part #	Description	Qty.	Part #	Description	Qty.
E81896	BOLT, CARRIAGE, M6 X 16 MM LG SS	2	E84770	SQUEEGEE SUPPORT BRACKET	1
E81531	SQUEEGEE WHEEL	2	E84771	SQUEEGEE MOUNTING BRACKET	1
E22346	SQUEEGEE RETENTION PIN	2	E84772	FRONT SQUEEGEE	1
E81897	WHEEL BUSHING	2	E84773	REAR SQUEEGEE	1
E84768	UPPER SQUEEGEE SEAL	1	E84774	SQUEEGEE RETENTION KNOB	2
E84769	LOWER SQUEEGEE SEAL	1	E84775	SQUEEGEE RETENTION SPRING	2

DIAGRAM 5 REAR COVER

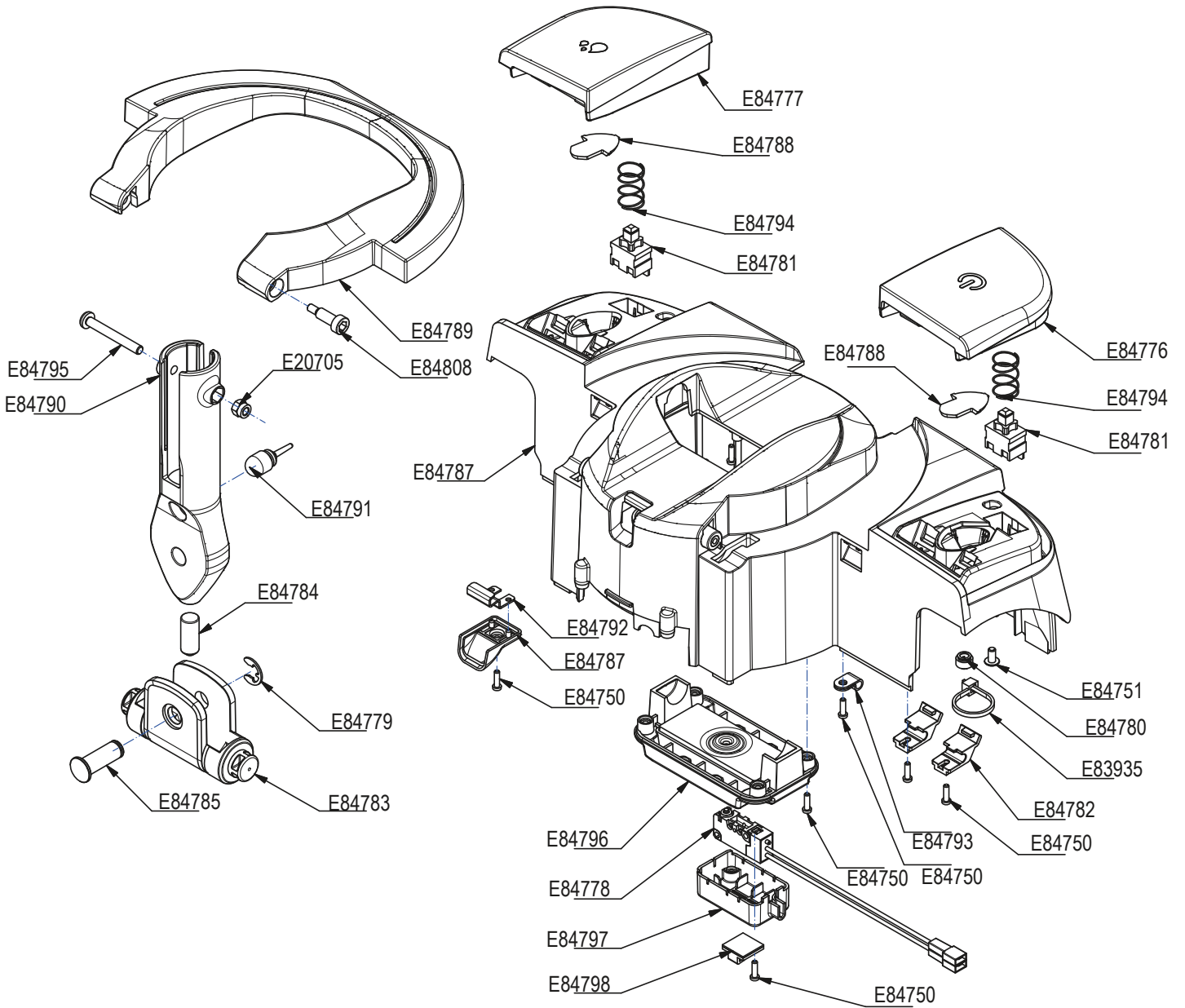

DIAGRAM 5 PARTS LISTING

Part #	Description	Qty.	Part #	Description	Qty.
E84776	POWER ON/OFF BUTTON	1	E84788	LIGHT DIFFUSER	2
E84777	WATER PUMP ON/OFF	1	E84789	CARRY HANDLE	1
E84778	HANDLE POSTION SWITCH	1	E84790	UPPER HANDLE PIVOT	1
E84779	HANDLE PIVOT CIRCLIP	1	E84791	HANDLE BUMPER	1
E20705	NUT, NYLOC HEX M5	1	E84808	CARRY HANDLE PIN	2
E84780	LED HOUSING	2	E84792	SUPPORT CLIP	1
E83935	WIRE TIE	2	E84793	CABLE TIE	2
E84781	ON/OFF SWITCH	2	E84794	BUTTON SPRING	2
E84782	BUTTON PIVOT PLATE	4	E84750	SCREW, PAN HEAD, PHIL SELF TAPPING M3 X 10 MM LG	19
E84783	LOWER HANDLE PIVOT	1	E84751	SCREW, PAN HEAD, PHIL SELF TAPPING M4 X 8 MM LG	2
E84784	HANDLE DETENT	1	E84795	SCREW, FILISTER HEAD, PHIL M5 X 40 MM LG	1
E84785	HANDLE PIVOT PIN	1	E84796	STRIKER PLATE	1
E84786	REAR COVER	1	E84797	HANDLE POSITION SWITCH HOUSING	1
E84787	COVER	1	E84798	CABLE CLIP	1

DIAGRAM 6 FRONT COVER

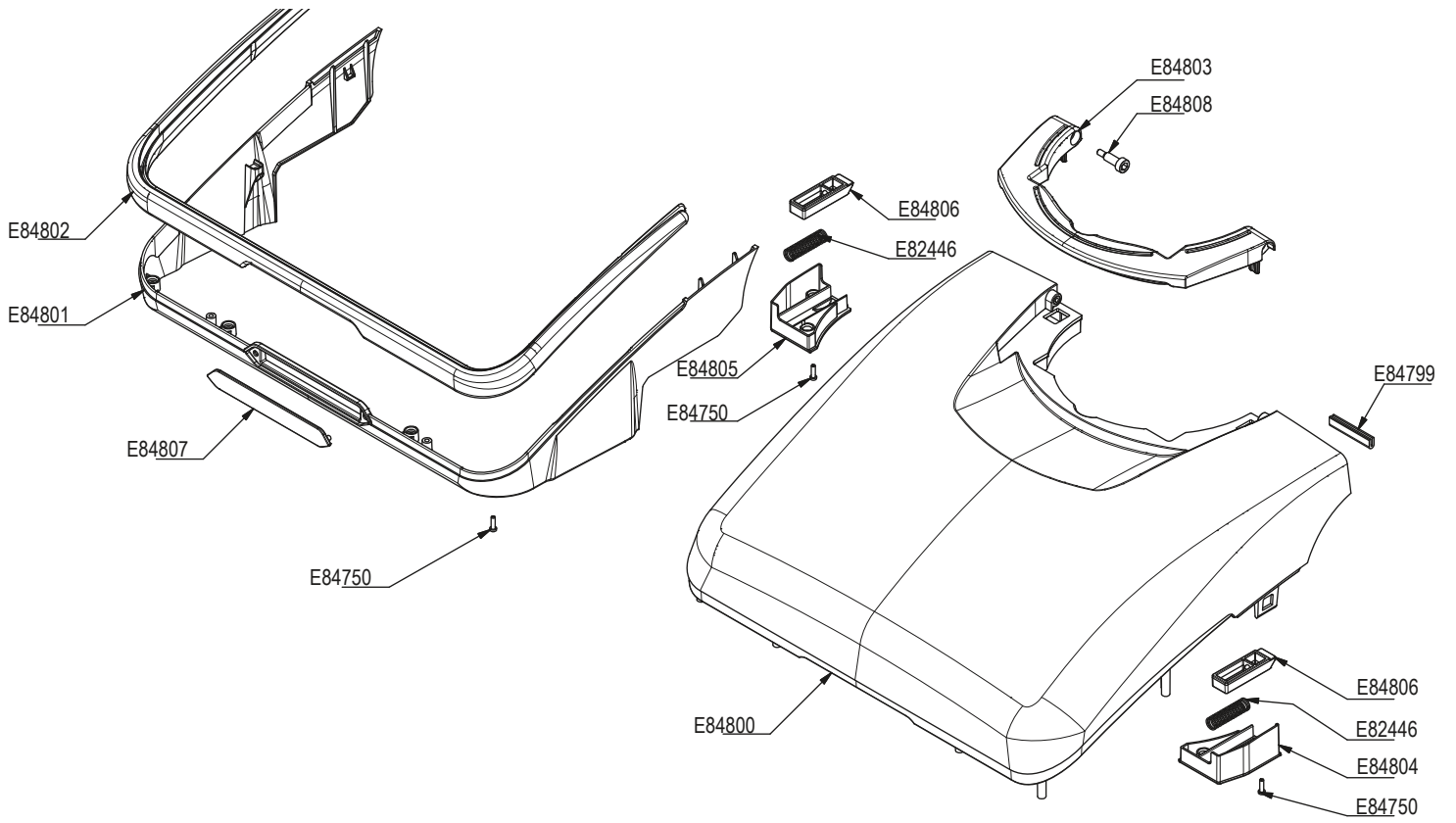

DIAGRAM 6 PARTS LISTING

Part #	Description	Qty.	Part #	Description	Qty.
E84799	RUBBER SCUFF GUARD	1	E84804	LEFT LATCH HOUSING	1
E82446	COVER LATCH SPRING	2	E84805	RIGHT LATCH HOUSING	1
E84800	FRONT UPPER COVER	1	E84806	COVER LATCH	2
E84801	FRONT LOWER COVER	1	E84807	LED LENS	1
E84802	FRONT BUMPER	1	E84808	COVER LATCH PIN	2
E84803	COVER LATCH HANDLE	1	E84750	SCREW, PAN HEAD, PHIL SELF TAPPING M3 X 10 MM LG	10

DIAGRAM 7 SOLUTION TANK

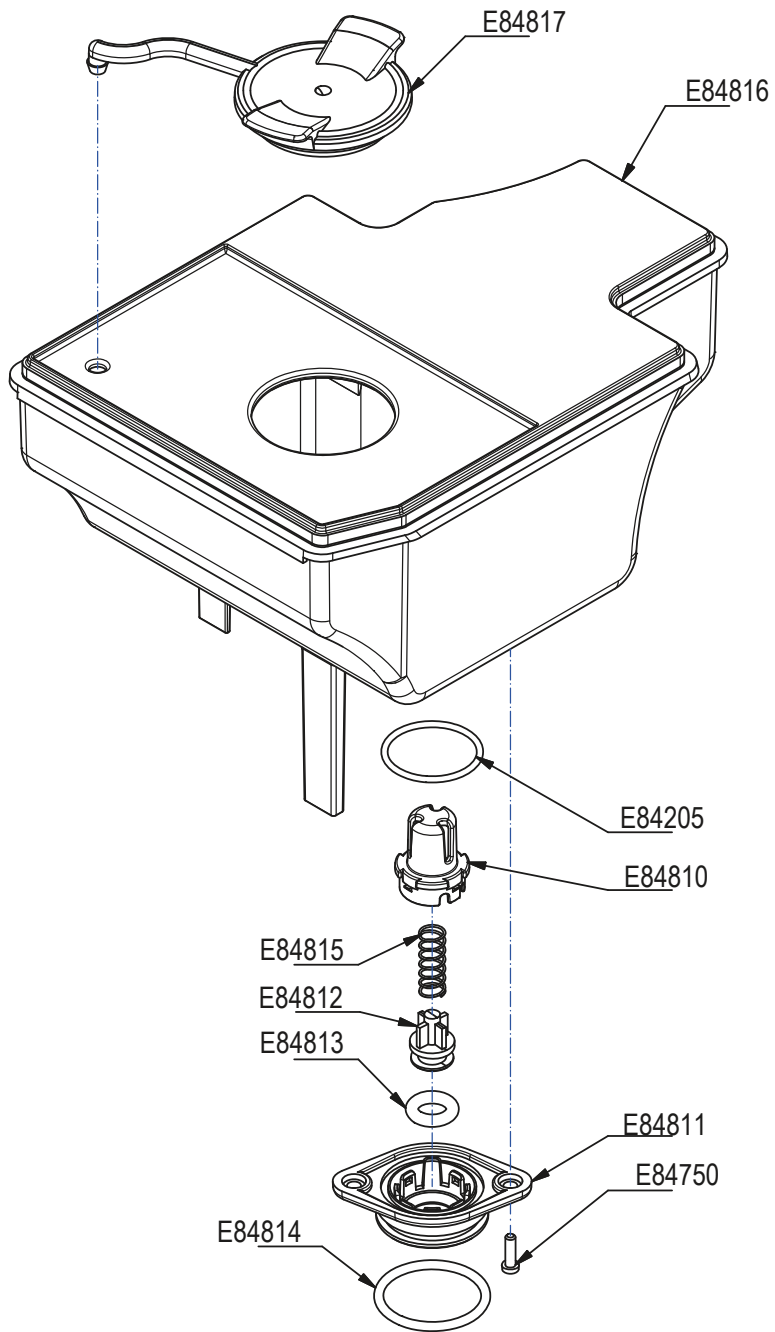
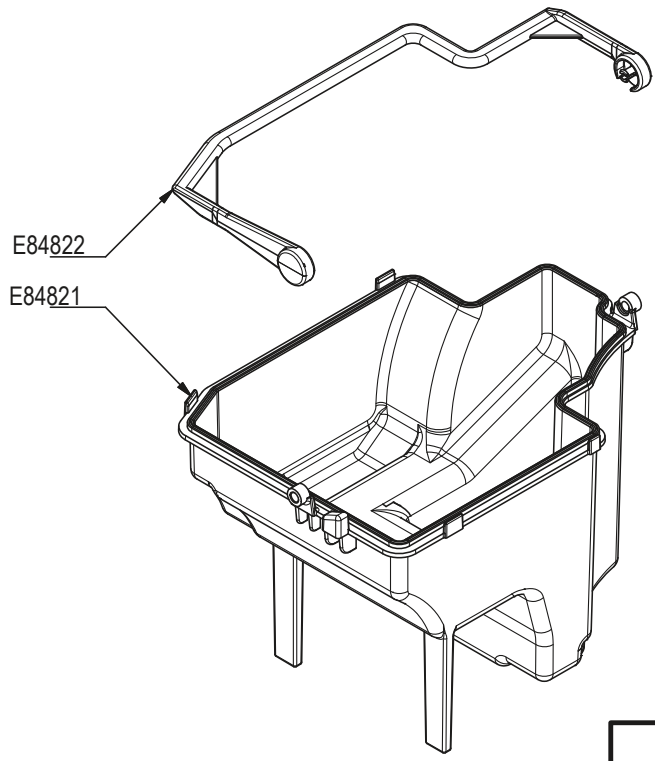

DIAGRAM 7 PARTS LISTING

Part #	Description	Qty.	Part #	Description	Qty.
E84809	VALVE ASSEMBLY	1	E84814	O-RING	1
E84205	O-RING	1	E84815	VALVE SPRING	1
E84810	UPPER VALVE BODY	1	E84817	RESERVOIR CAP	1
E84811	LOWER VALVE BODY	1	E84816	SOLUTION TANK	1
E84812	VALVE PLUNGER	1	E84750	SCREW, PAN HEAD, PHIL SELF TAPPING M3 X 10 MM LG SS	2
E84813	O-RING	1			

DIAGRAM 8 RECOVERY TANK



E84818 Assembly

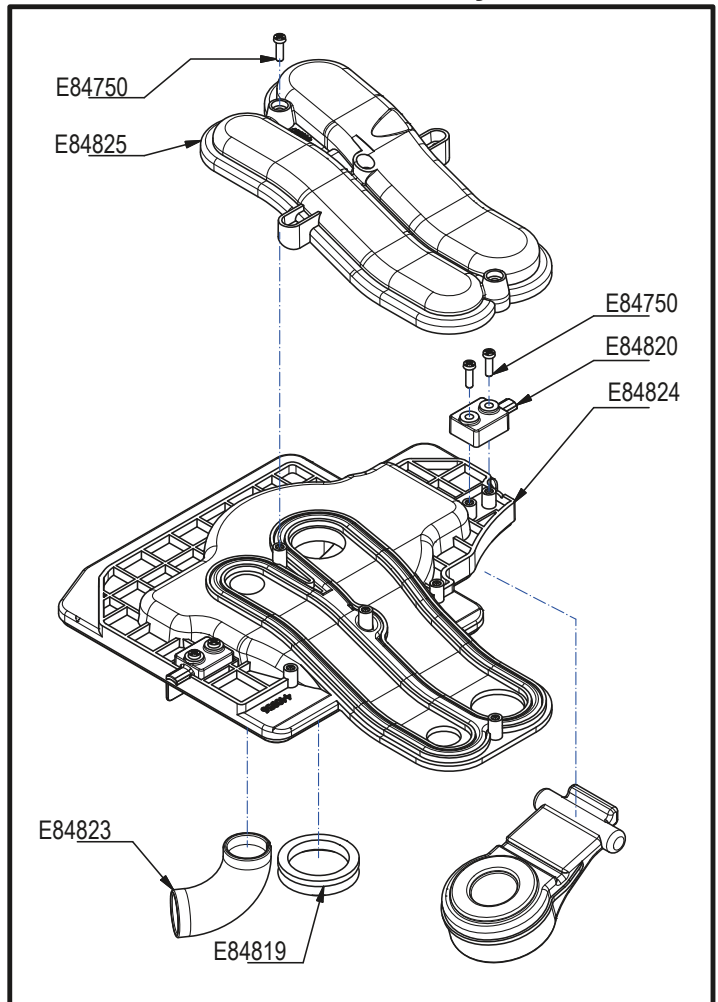

DIAGRAM 8 PARTS LISTING

Part #	Description	Qty.	Part #	Description	Qty.
E84818	RECOVERY TANK COVER ASSEMBLY	1	E84825	UPPER RECOVERY TANK COVER	1
E84819	V-RING GASKET	1	E84750	SCREW, PAN HEAD, PHIL SELF TAPPING M3 X 10 MM LG SS	9
E84820	HANDLE PIVOT INSERT	2	E84826	FLOAT	1
E84823	RUBBER PIPE ELBOW	1	E84821	RECOVERY TANK	1
E84824	LOWER RECOVERY TANK COVER	1	E84822	RECOVERY TANK HANDLE	1

DIAGRAM 9 VACUUM ASSEMBLY

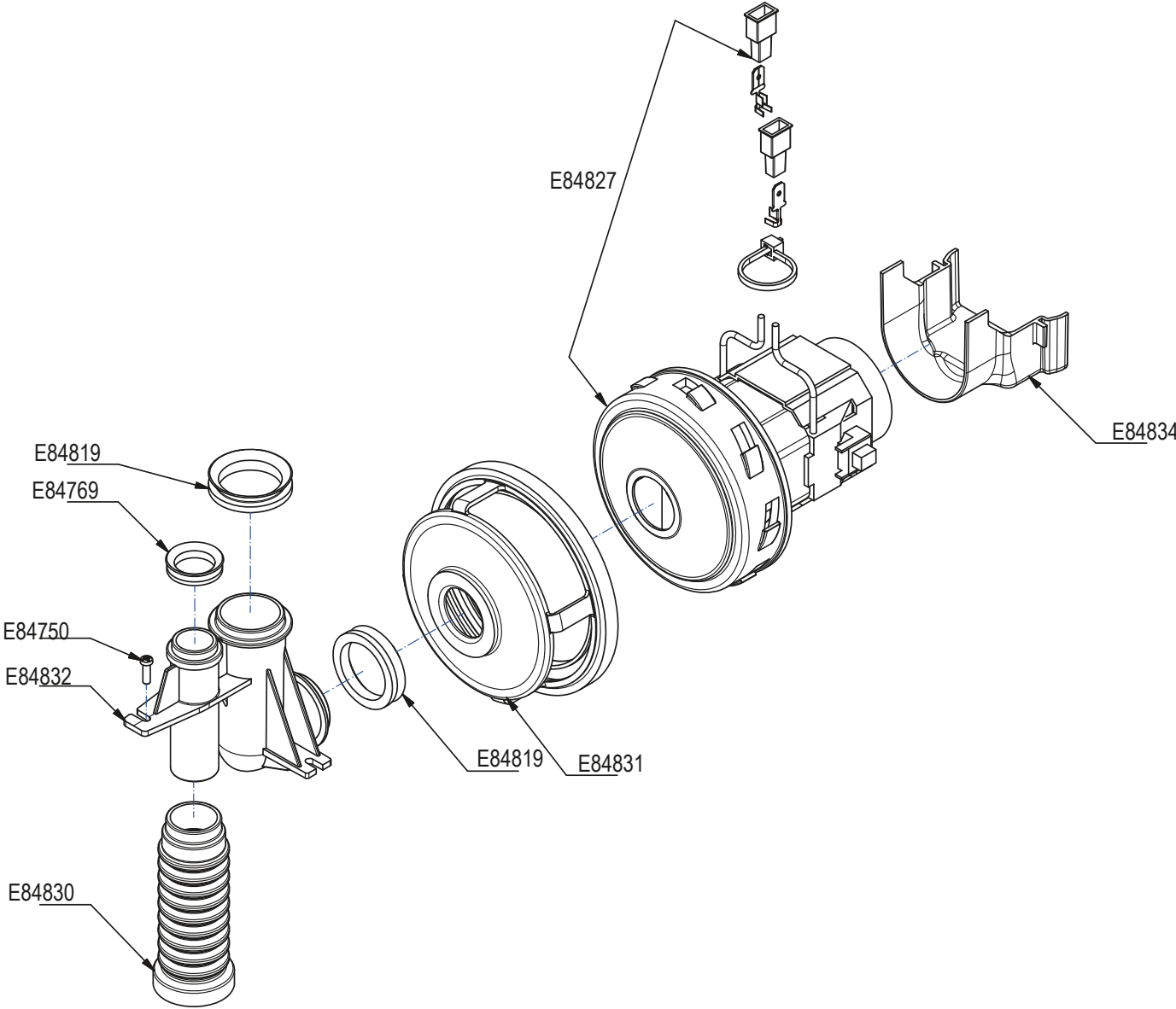

DIAGRAM 9 PARTS LISTING

Part #	Description	Qty.	Part #	Description	Qty.
E84827	VACUUM MOTOR ASSEMBLY, 24V 100W	1	E84831	V-RING GASKET	1
E84819	V-RING GASKET	2	E84832	VACUUM MANIFOLD	1
E84830	VACUUM HOSE	1	E84750	SCREW, PAN HEAD, PHIL SELF TAPPING M3 X 10 MM LG	3
E84769	V-RING GASKET	1	E84834	EXHAUST CHANNEL	1

DIAGRAM 10 SOLUTION DELIVERY

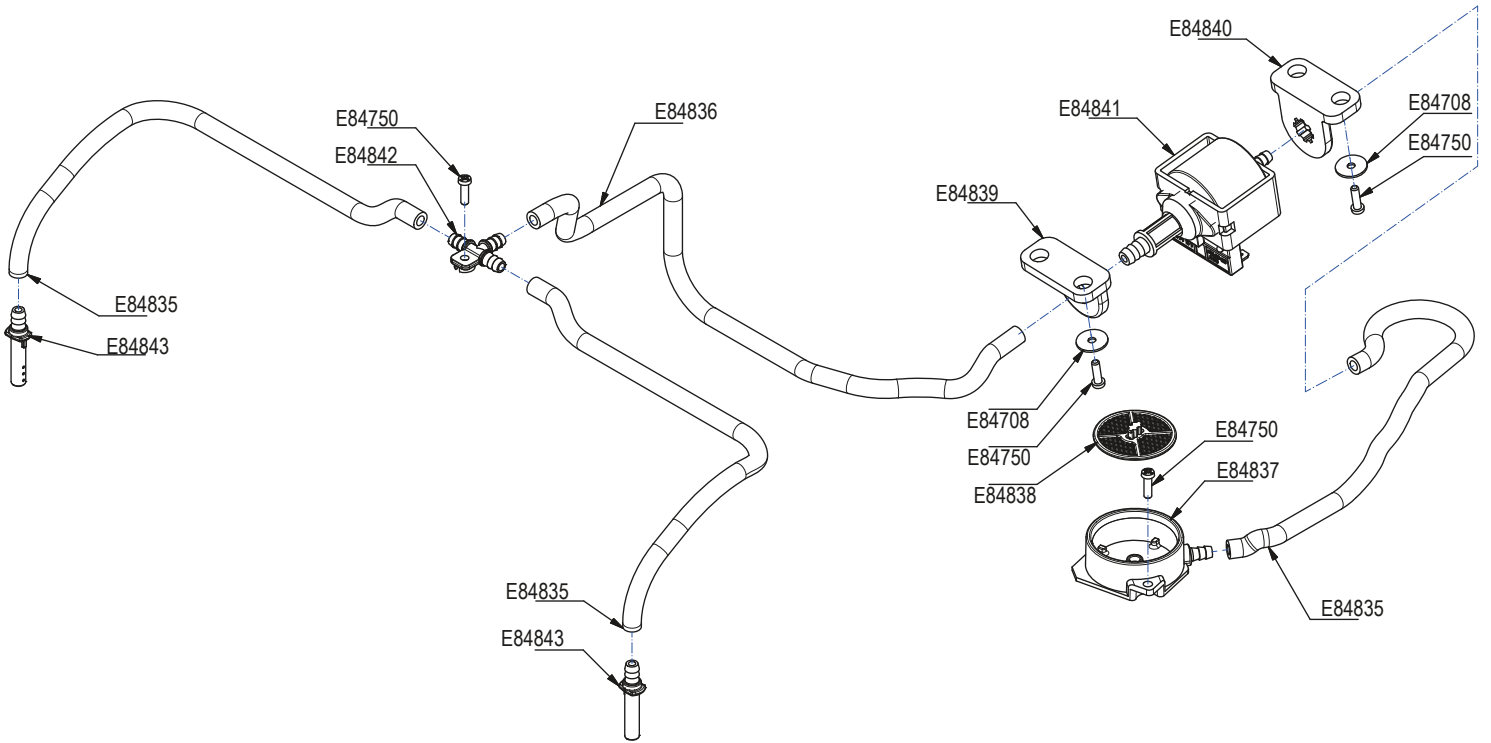

DIAGRAM 10 PARTS LISTING

Part #	Description	Qty.	Part #	Description	Qty.
E84835	SILICONE HOSE, 70D X 4ID X 225L	3	E84840	REAR PUMP MOUNT	1
E84836	SILICONE HOSE, 70D X 4ID X 350L	1	E84841	SOLUTION PUMP	1
E84708	WASHER, FFENDER, M3 X 12 X 0.8 ZINC	4	E84842	SOLUTION HOSE T-FITTING	1
E84837	VALVE HOUSING	1	E84843	SOLUTION NOZZLE	2
E84838	FILTER SCREEN	1	E84750	SCREW, PAN HEAD, PHIL SELF TAPPING M3 X 10 MM LG	7
E84839	FRONT PUMP MOUNT	1			

BETCO US WARRANTY POLICY

10 year coverage

Subject to the conditions stated below, Betco warrants parts and labor on rotationally molded polyethylene tanks/ housings and injection molded vacuum head assemblies to be free from defects in materials and workmanship for a period of ten years to the original purchaser.

3 Year Coverage

Subject to the conditions stated below, Betco warrants parts and labor on all other Betco components to be free from defects in materials and workmanship for a period of three years to the original purchaser.

- Lithium Ion battery for MotoMop™ is a full 3 years

1 Year Coverage

Subject to the conditions stated below, Betco offers a limited warranty on parts and labor on the following equipment: parts and accessories to be free from defects in materials and workmanship for a period of one year to the original purchaser.

- PowerUp™ 14 Upright Vacuum: #E29990-00
- Bac Pac Lite Vacuum: #85903-00
- FiberPRO® Floor Dryer: #85507-00
- WORKMAN™ Series Vacuums: #85024-00, #85025-00, #83012-00, #85027-00
- All Tools and Accessories
- All Battery Chargers
- Deep cycle batteries are pro-rated for 1 year

Allowable Travel Time Warranty Reimbursement:

Eligible equipment: All battery and propane powered equipment products. Warranty period: 90 days from date of sale to the original purchaser. A maximum 180 mile round trip at 50 cents per mile will be allowed for warranty consideration.

Propane Machine Warranty:

Kawasaki engines are warranted by Kawasaki for a period of 2 years against manufacturer defects. All other components (except wear items)* are warranted by Betco for a period of 3 years.

***Wear Items exempt from Warranty consideration include but may not be limited to: power cords, transport wheels, vacuum bags, belts, squeegee blades, pad drivers, clutch plates, handle grips, filters, screens, throttle cables, brushes and carbon brushes.**

Subject to the conditions and exceptions stated in this warranty, Betco warrants the Betco products to be free from defects in material and workmanship, under normal use and service, for the periods listed under the warranty policy to the original purchaser. At any time during the warranty period, Betco will furnish replacement parts for the Betco parts to the original purchaser. Such parts will be furnished and charged including transportation costs, to the original owner through any Betco authorized Service Distributor. If the original part is returned within the warranty policy period from date of delivery for inspection by Betco and is found to be defective the owner will be credited for the cost of replacement parts plus shipping and handling. Replacement parts that have become defective through wear or abuse are not included in this warranty.

This warranty does not apply to damage or defect caused by accident, misuse, Negligence, fire, or to any Betco product which has been serviced or repaired by other than an authorized Betco Service Distributor or Betco factory personnel. This warranty is void if products are used for any purpose other than that which was intended. There are no other warranties expressed or implied. In no event shall Betco be liable for incidental or consequential damages or any damage to person or property. (Please note some states do not allow the exclusion or limitations for incidental and consequential damages).

