



Electronic Service Manuals

This electronic document is provided as a service to our customers. We do not create the contents of the information contained in this document. Should you have detailed questions pertaining to the information contained in this document, you may contact Michco, or the manufacturer which provided the original information in this electronic deliverable. Michco's only part in this electronic deliverable was the electronic assembly process. By providing this manual on line we are not guaranteeing parts availability.

You may contact Michco through the following methods:

Phone (517) 484-9312 or (800) 331-3339

2011 N. High St. -- Lansing, Michigan -- 48906

Fax: (517) 484-9836

Email: CustServe@Michco.com

Web site: www.Michco.Com

Parts Web site: www.FloorMachineParts.Com

Order Parts on Line at:

www.FloorMachineParts.Com

Directly to Parts & Service:

By Email: **Shop@Michco.com**

By Fax: (517) 702-2041

By Voice: Use numbers above.

Serving the Cleaning Industry Since 1922

Notice: All copyrighted material remains property of original owners, all trademarks are property of respective owners. Manuals are subject to Manufacturer's reproduction limitations. Originals or reproductions were provided by manufacturers through a request. We make no warranty as to the correctness of information provided in this document and you assume all risk. By placing these manuals on line we are not declaring our corporation to be an manufacturer authorized dealer or provider, please check our web site for authorized manufacturers we represent.

MPV-60



Service Manual

American-Lincoln Models: 578-618, 578-619, 578-620, 578-621
578-622, 578-623

American-Lincoln®

8/06 FORM NO. 56043109

TABLE OF CONTENTS

SERVICE PRECAUTIONS	3
SERVICE CHART	4
SERVICE INSTRUCTIONS	6
MAIN BROOM.....	6
TO CHECK THE MAIN BROOM SWEEP PATTERN	6
TO ADJUST THE MAIN BROOM SWEEP HEIGHT.....	6
TO REPLACE THE MAIN BROOM.....	6
MAIN BROOM LEVEL ADJUSTMENT.....	6
SIDE BROOM	7
TO CHECK THE SIDE BROOM SWEEP PATTERN	7
TO CHANGE THE SIDE BROOM HEIGHT ADJUSTMENT	7
TO CHANGE THE SIDE BROOM.....	7
HOPPER	8
TO CLEAN HOPPER	8
TO CHECK HOPPER SEALS	8
TO CHECK HOPPER FLAPS	8
DUST FLAPS	8
TO CHECK THE DUST FLAPS.....	8
TO ADJUST THE DUST FLAPS	8
DUST CONTROL FILTER	9
TO CHECK THE DUST CONTROL FILTER	9
TO CLEAN THE DUST CONTROL FILTER.....	9
TO CHANGE THE DUST CONTROL FILTER.....	9
TO CHECK THE VIBRATION ARM.....	9
BRAKE SERVICE	10
BRAKE PEDAL ADJUSTMENT.....	10
BRAKE DRUM ADJUSTMENT	10
HYDRAULIC SYSTEM SERVICE	11
HYDRAULIC OIL COOLER.....	11
TO FILL THE HYDRAULIC RESERVOIR	11
TO CLEAN THE HYDRAULIC SYSTEM.....	11
TO DRAIN THE HYDRAULIC RESERVOIR	11
TO CLEAN THE HYDRAULIC SUCTION STRAINER	12
TO REPLACE THE RETURN FILTER ELEMENT	12
ENGINE AIR INTAKE SERVICE	13
AIR FILTER	13
TO REPLACE AIR FILTER ELEMENT.....	13
ENGINE COOLING SYSTEM SERVICE	14
HOSES.....	14
RADIATOR	14
COOLANT LEVEL.....	14
DRIVE BELTS	14
BATTERY	14
LP SAFETY PRECAUTIONS	15
LP COMPONENTS	16
LP FUEL SYSTEM	16
LP VAPOR WITHDRAWAL SYSTEM.....	16
LP CHECKLIST	16
LP VAPORIZER-REGULATOR QUICK CHECK	16
LP FUEL TANKS	17
USE AND CARE OF LP TANKS	17
CHANGING LP FUEL TANKS.....	18
STORAGE OF LP FUEL TANKS.....	18
STANDARD METRIC ENGINE TORQUE REQUIREMENTS	19
HYDRAULIC TORQUE REQUIREMENTS	20
BOLT IDENTIFICATION CHART	21
DECIMAL-METRIC CONVERSION TABLE	22
HARDWARE ABBREVIATIONS	23
HARDWARE LEGEND	24
CHECK ENGINE LIGHT CODES	30
ORDERING PARTS	33

SERVICE PRECAUTIONS



WARNING

Do not attempt to Service this Machine until you have read and understand all Safety Warnings associated with the equipment you are working on.



WARNING

Electrical repairs must be done by authorized personnel only. Consult your American-Lincoln Authorized Service Person to do service procedures. Use only genuine American-Lincoln parts.



WARNING

Unexpected movement could cause injury. Always park on a level surface, turn key off, and engage parking brake before working on the machine.



WARNING

Maintenance and repairs must be done by authorized personnel only. Always empty the Hopper and Disconnect the Batteries before doing any maintenance. Keep all fasteners tight. Keep adjustments according to the specifications as shown in the Service Manual for this machine.



WARNING

Always wear eye protection and protective clothing when working near batteries. Do not put tools or other metal objects across the tops of the batteries. NO SMOKING.



WARNING

Hopper Could Fall And Cause Serious Injury. Always Engage Hopper Safety Arm Before Working Under Hopper.



WARNING

Moving Fan And Belt Could Cause Injury. Stay Clear Of Moving Parts.



WARNING

Pinch Points Could Cause Injury. Stay Clear Of Moving Parts.



WARNING

To Maintain The Stability Of This Sweeper In Normal Operation, the Over- Head Guard, Counterweights, rear Bumper Guard, Or Any Similar Equipment, Installed by The Manufacturer As Original Equipment, Should Never Be Removed. If It Becomes Necessary To Remove Such Equipment For Repair Or Maintenance. This Equipment Must Be Reinstalled Before The Sweeper Is Placed Back In Operation.



WARNING

The Wheels Are A Split Rim Type Which Could Explode Causing Personal Injury. To Prevent Injury Deflate Tires Before Removing From The Machine For Service.



WARNING

To Prevent Injury Or Engine Damage Never Remove The Radiator Cap Under Any Conditions While The Engine Is Running Or When It Is Hot. To Prevent Burns From Steam Or Scalding Hot Coolant Being Expelled From The Radiator, Use Extreme Care When Removing The Radiator Cap. Wait Until The Engine Has Cooled.

SERVICE CHART

EVERY 8 HOURS or DAILY operation check and clean/adjust if necessary:

1. Inspect panel filter for damage and clean.
2. Check engine oil level
3. Check hydraulic fluid level
4. Check radiator cooling fins for blockage
5. Check all flaps for wear or damage
6. Check brooms for wear or damage, adjust as required
7. Check brake pedal and parking brake
8. Clean engine air filter dust cap and check filter
9. Check hydraulic oil filter
10. Check coolant level
11. Check LP connections for odor.

EVERY 50 HOURS

12. Check tension on all belts
13. Check battery electrolyte level
14. Lubricate dump system
15. Check all hydraulic hoses for wear or cuts
16. Rotate main broom (end for end)
17. Clean or replace panel filters
18. Perform recommended engine maintenance (See engine manual)

EVERY 100 HOURS

19. Change crankcase oil.
20. Change engine oil filter.
21. Check fuel hose for leaks or deterioration.
22. Check radiator hoses and clamps.
23. Lubricate steering yoke pivot bearings.
24. Lubricate front wheel bearings.
25. Lubricate all moving joints.
26. Check brake pads for wear and adjustment.
27. Lubricate all 4 "DANHOUSER" bushings with NAPA #765-1363 (or equivalent) anti-seize lubricant. The bushings are located on the steering, hopper lift, and dump door cylinders.
28. Perform recommended engine maintenance (See engine manual)

EVERY 250 HOURS

29. Replace engine air filter element
30. Flush radiator coolant system
31. Remove spark plugs - clean or replace
32. Clean and lubricate governor linkage (Diesel)
33. Replace fuel filter
34. Replace hydraulic filter element
35. Perform recommended engine maintenance (See engine manual)

EVERY 500 HOURS

36. Clean hydraulic reservoir
37. Clean hydraulic intake strainer
38. Change hydraulic fluid
39. Perform recommended engine maintenance (See engine manual)

Refer all Maintenance and Service Requirements to Qualified Maintenance Personnel.

SERVICE CHART

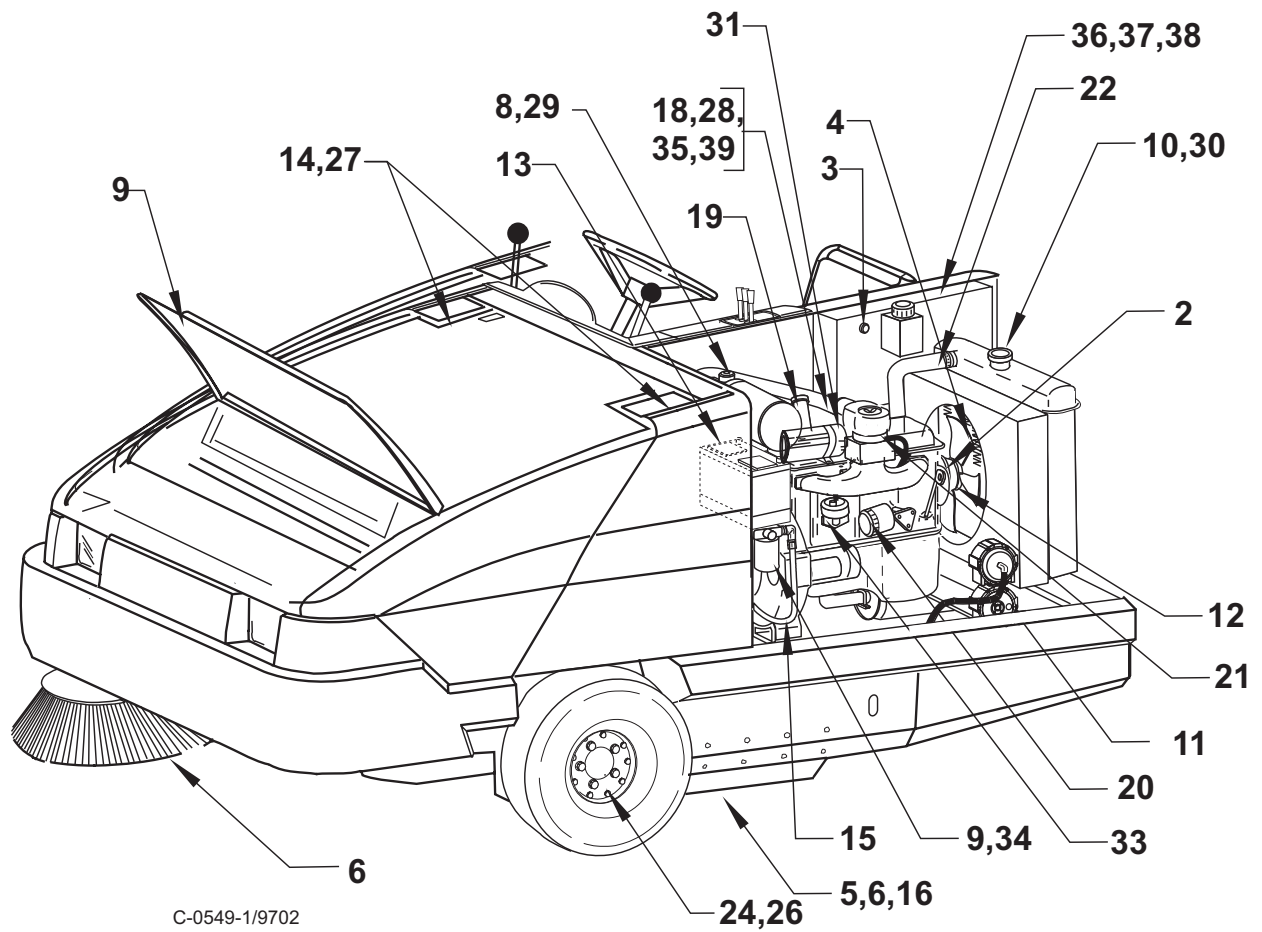
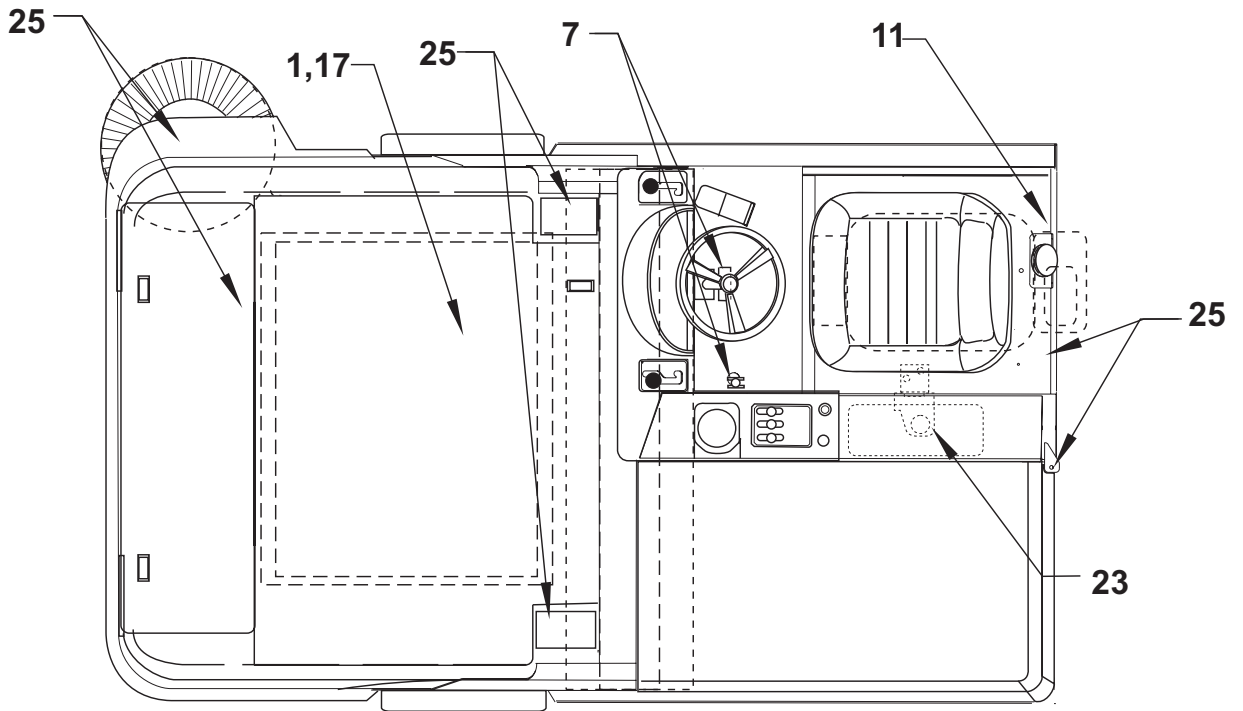

C-0549-1/9702

SERVICE INSTRUCTIONS

SWEEPING SYSTEM SERVICE

MAIN BROOM

To prevent the broom from "setting" in one direction and to provide the maximum life of the broom it is recommended that the broom be turned end for end periodically.

TO CHECK THE MAIN BROOM SWEEP PATTERN

Check the main broom sweep pattern after changing the broom or when poor sweeping performance is encountered while sweeping.

1. While the machine is not moving, lower the main broom to the "SWEEP" position and let machine sweep in one spot for a short period of time.
2. Before moving machine, raise main broom lever to the "UP" position and move the sweeper forward enough to see the pattern left by the main broom bristles on the floor.
3. Check the width of the pattern on the floor to determine if the main broom requires adjustment.
 - A normal sweep pattern left on the floor will be between 1 and 2 inches wide.
 - A pattern that is more than 2 inches wide indicates the broom linkage needs to be adjusted "UP"
 - A pattern that is less than 1 inch wide indicates the broom linkage needs to be adjusted "DOWN"

TO ADJUST THE MAIN BROOM HEIGHT

When changing the sweep height adjustment it is recommended that the bolt be adjusted 1 turn at a time. After adjustment, recheck the sweep pattern to determine if further adjustment is necessary.

- Turn the adjustment knob counterclockwise to INCREASE the sweep pattern width.
- Turn the adjustment knob clockwise to DECREASE the sweep pattern width.

TO REPLACE THE MAIN BROOM

The Main Broom should be replaced when the bristles become worn to less than 2". The main broom is held in place by the right side broom door. This feature provides for easy removal and installation of the main broom without the need for special tools or equipment. Follow the instructions below for main broom removal & replacement.

1. Park sweeper on a smooth level surface, engage parking brake, turn key switch "OFF", place the main broom lever in the "SWEEP" position.
2. Lift the door latch to open the right side broom door.
3. Swing the broom drive idler hub out to clear the main broom.
4. Remove the broom from the broom compartment.
5. Install the replacement broom. Pay special attention to the slots on the broom, it may be necessary to rotate the broom so the tabs on the drive hub align with the slots on the broom.
6. Swing the idler hub to engage the main broom and close the access door. Check the door latch for proper engagement when closed.
7. Check the Main Broom sweep pattern and adjust as necessary.

MAIN BROOM LEVEL ADJUSTMENT

The main broom level is factory set and should not need adjustment. If the level becomes out of adjustment and the broom bristle contact pattern is not an even 2" to 3" wide, the broom arm lift frame will need to be adjusted. The frame is supported by two plates located inside the broom doors. The carriage bolts that secure the plates to the frame will need to be loosened. The frame can then be leveled and the bolts tightened.

SIDE BROOMS SERVICE

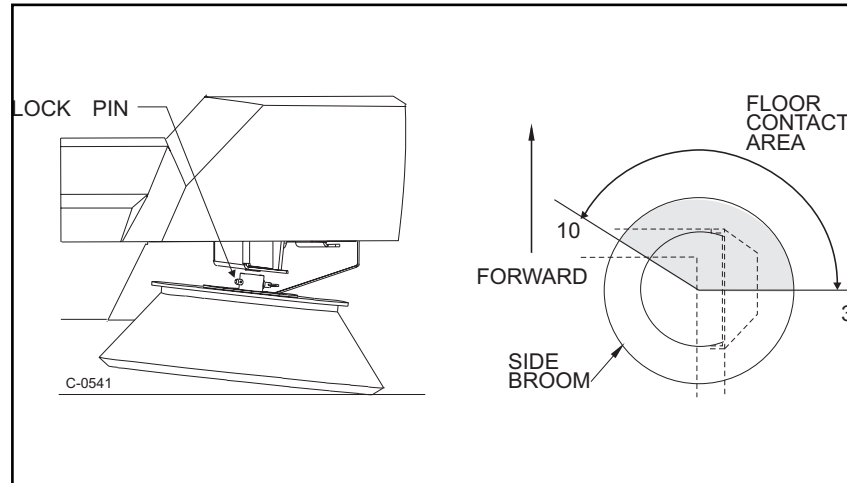

C-0541

FIGURE 33

SIDE BROOM

The Side Broom sweeping angle is not adjustable however the height of the side brooms can be adjusted to compensate for wear as the broom becomes worn from use. Always check and adjust the sweep pattern after changing the side broom.

TO CHECK THE SIDE BROOM SWEEP PATTERN

1. Park the machine on a smooth level surface and turn the Side Broom Switch to the "ON" position.
2. Place the Side Broom Lever in the "DOWN" position.
3. Move the Brooms Control Lever to the "ON" position.
4. While staying in place allow the side broom to sweep for a short period of time. (Allow enough time for the side broom to leave a clean footprint on the floor).
5. Place the Side Broom Lever in the "UP" position.
6. Move the Brooms Control lever to the "OFF" position.
7. Back the sweeper away from the area where the Pattern was left.
8. Turn Key Switch to the "OFF" position and engage parking brake.
9. Leave operator's compartment and check the pattern to determine the Floor Contact area.
10. Determine if adjustment to the side brooms height is necessary by examining the floor contact are broom should contact the floor as shown in fig. 34 above.

If the contact area on the floor does not match the diagram, do one of the following:

- Lower the broom adjustment to increase the size of the pattern
- Raise the broom adjustment to decrease the size of the pattern.

TO ADJUST THE SIDE BROOM HEIGHT

Turn the side broom adjustment knob to change the side broom sweep height. Turn the adjustment knob counterclockwise to INCREASE the sweep pattern width. Turn the adjustment knob clockwise to DECREASE the sweep pattern width. Recheck for proper sweep pattern after adjustment.

TO CHANGE THE SIDE BROOM

Change the side broom when the bristles become worn to less than 3 inches length.

1. Park Machine on a smooth level surface, turn key switch to "OFF" Position and engage Parking Brake.
2. Place the side broom lever in the "UP" Position.
3. Remove the lock pin that holds the broom flange to the motor shaft.
4. Disassemble the flange from the broom by removing the screws that hold the flange to the broom.
5. Assemble the flange to the replacement Broom and fasten using the hardware removed.
6. Install the replacement broom on the shaft and insert the lockpin.

SERVICE INSTRUCTIONS

HOPPER SERVICE

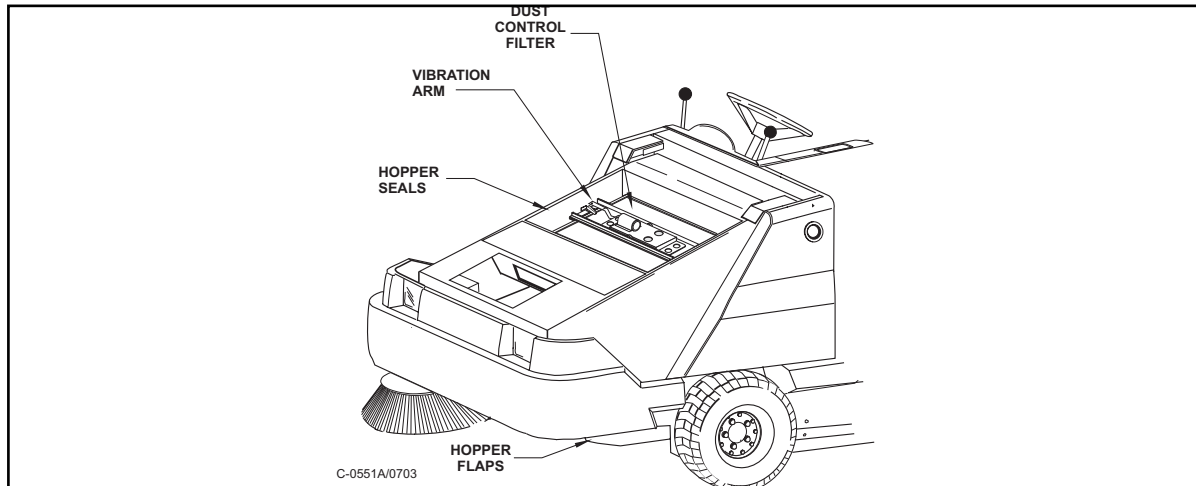

C-0551A

FIGURE 34

HOPPER

The hopper houses the debris compartment, the dust control filter and the vibrating arm. For maximum performance and service life, keep the hopper clean and inspect the seals and flaps daily.

Clean the hopper prior to parking the sweeper at the end of the day. A clean hopper will make inspecting the flaps and seals much easier and will prevent premature deterioration of hopper components. Do not leave the hopper full of debris while in storage or when parked for extended periods of time

TO CLEAN HOPPER

Once the hopper has been emptied the insides of the hopper should be rinsed out with water.

TO CHECK HOPPER SEALS

The Hopper seals are important to positive dust control while sweeping. Damaged seals will reduce vacuum pressure at the broom. Inspect for cuts, tears and proper positioning of the seal material. Replace all seals that become damaged.

DUST FLAPS

The dust flaps are very important to sweeping and dust control and are susceptible to damage and should be inspected daily and maintained in good condition.

TO CHECK THE DUST FLAPS

The Dust Flaps are used on the Wheel Well, Broom Chamber and Broom Door. Inspect the Flaps daily and replace any flap that shows signs of wear or deterioration. All flaps should be replaced when worn or damaged to the point that they can no longer perform their normal function. The adjustable Flaps have slotted mounting holes to facilitate adjustment.

TO ADJUST THE DUST FLAPS

Adjust the flaps so there is a 1/8" to 1/16" Gap between the floor and the bottom edge of the flaps. The rear flap adjustment is 1/16" (16 cm.) above the floor.

1. Park Sweeper on a smooth level surface and engage the Parking Brake.
2. Loosen the Flap retaining screws and adjust the flap to clear the floor and leave a 1/16" to 1/8" Gap.
3. Tighten Flap retaining screws while holding flap in position.
4. Drive sweeper on a smooth surface and recheck the flaps for proper floor clearance.

**HOPPER SERVICE-Cont.
DUST CONTROL FILTER**

The dust control filter should be checked daily for damage and cleaned if necessary. A damaged filter must be replaced to prevent damage to other dust control system components. Inspect the filter for tears in the filter media or excessive dirt lodged in the pleats. A tear in the filter media will allow dirt to pass through the filter and can be easily seen as a dirty patch on the top side on the filter. Cleaning of the filter is necessary when the filter shaker fails to adequately clean the pleats.

TO CHECK THE DUST CONTROL FILTER

1. Park the sweeper on a smooth level surface, Turn the key switch to the "OFF" position and engage the Parking Brake.
2. Raise the hopper lid for access to the filter compartment.
3. Turn the filter latch, lift the filter frame and remove the filter.
4. Inspect the panel filter for tears and clean or replace if necessary.
5. Reinstall the filter, lower the filter frame and engage the filter latch.
6. Close the hopper cover and lock the hopper cover latch.

TO CLEAN THE DUST CONTROL FILTER

Clean the dust control filter when the shaker fails to adequately clear the filter. The filter can be cleaned with compressed air not to exceed 100 psi.

To clean the filter with compressed air, apply the compressed air to the top side of the panel to flush out the lodged dirt from the filter pleats. Be careful to not damage the filter media while cleaning.

The filter can be cleaned with a solution of soap and water. If this cleaning method is used do not use the filter until it has completely dried.

TO CHANGE THE DUST CONTROL FILTER

Change the filter panel when damage is evident.

1. Park the sweeper on a smooth level surface, Turn the key switch to the "OFF" position and engage the Parking Brake.
2. Open the hopper cover latch and raise the cover to gain access to the filter compartment.
3. Turn the latch on the hinged frame counterclockwise and lift the frame.
4. Remove the filter panel.
5. Install replacement filter, lower the hinged frame and engage the latch.
6. Lower the hopper cover and lock the cover latch.

TO CHECK THE VIBRATION ARM

1. Inspect the arm daily to assure it is located directly over the bolt.
2. Inspect the arm to assure there is between 1/32" to 1/16" clearance between the bolt and the arm.
3. Inspect the gland nut to assure that it moves up and down with some drag, this will assure no leakage. (Silicone on the nut may be necessary to prevent loosening while vibrating)

SERVICE INSTRUCTIONS

BRAKE SERVICE

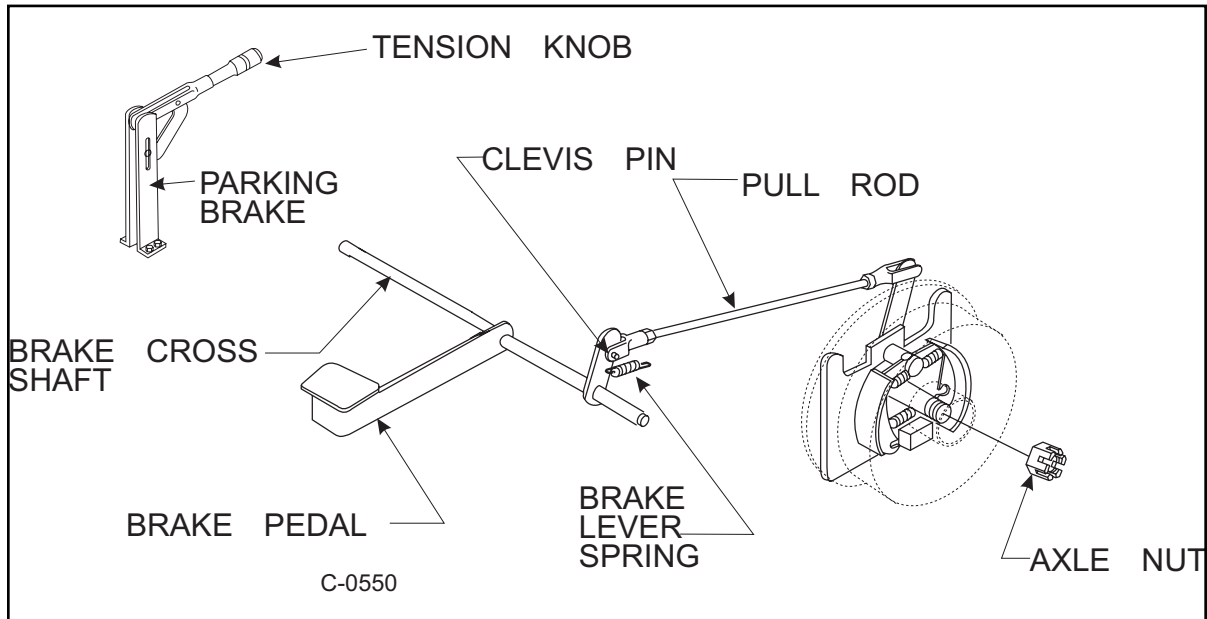

C0550

FIGURE 35

BRAKES

The service brakes are located on the front wheels. They are operated by the brake pedal and the parking brake lever. Check the Brakes daily for proper operation and inspect the brake pads for wear every 100 hours of operation.

BRAKE PEDAL ADJUSTMENT

Perform this adjustment to ensure proper pedal height and linkage operation. The brakes are properly adjusted when the brakes hold the sweeper on an 8 degree ramp. The brakes need adjusted if the Pedal travels closer than 1 inch to the floor of the operator's compartment when the brakes are fully engaged.



WARNING

Hopper Could Fall And Cause Serious Injury. Always Engage Hopper Safety Arm Before Working Under Hopper.



WARNING

Always park on a level surface, chock tires and Observe Safety Procedures when adjusting the brakes

TO ADJUST THE BRAKES

When adjusting the brake clevises be sure to adjust both sides the same amount to prevent uneven braking between the two sides. Follow these steps to adjust the brakes.

1. Empty the debris hopper.
2. Raise the hopper and engage the safety arm.
3. Stop the engine, chock the tires.
4. Remove clevis pins from both sides of the brake cross shaft.
5. Thread the clevis out to decrease brake pedal height or in to increase pedal height.
6. Adjust the brakes so the brakes hold the machine on an 8 degree ramp and the pedal travels no closer than 1 inch from the floor.
7. Reinstall the clevis pins.
8. Start the engine, lift the hopper and lower the hopper safety arm.
9. Lower the hopper and stop the engine.
10. Remove the wheel chocks.

HYDRAULIC SYSTEM SERVICE

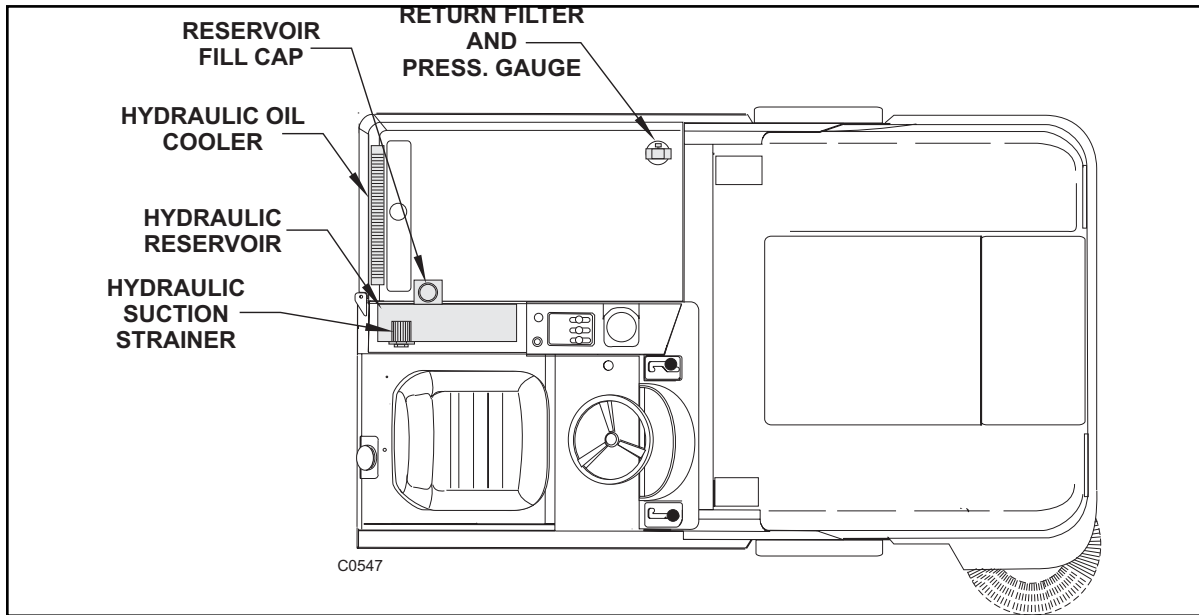

C-O547

FIGURE 36

HYDRAULIC SYSTEM

The brooms, hopper lift, hopper door, drive motor and vacuum fan are hydraulic powered. It is very important to prevent contamination in the hydraulic system. Contamination in the fluid will cause damage to all the hydraulic components. Follow the service chart and be very careful not to allow contaminants to enter the reservoir. Wipe the area surrounding the fill cap before opening.

HYDRAULIC OIL COOLER

The hydraulic oil cooler is located next to the radiator. The cooler can be accessed by opening the engine cover. The oil cooler core must be kept clear of debris and dust.

TO FILL THE HYDRAULIC RESERVOIR

Follow these instructions to add fluid to the reservoir as needed.

1. Open the engine cover.
2. Open the hydraulic reservoir breather filler cap.
3. Remove any debris that is in the breather filler cap screen
4. Fill the reservoir until the fluid is visible in the sight glass that is located on the side of the reservoir. Do not overfill the reservoir.
5. Close the hydraulic reservoir breather filler cap.
6. Close the engine cover.

TO CLEAN THE HYDRAULIC SYSTEM

To assure proper cleaning of the hydraulic system, follow and complete all steps below in order.

TO DRAIN THE HYDRAULIC RESERVOIR

Follow these instructions to drain the hydraulic reservoir.

1. Set the parking brake.
2. Open the engine cover.
3. Place a container under the reservoir drain to catch the reservoir fluid.
4. Remove the drain plug. The reservoir fluid will drain.
5. Properly Dispose of used fluid. Never refill the reservoir with used fluid.

SERVICE INSTRUCTIONS

HYDRAULIC SYSTEM SERVICE-Cont.

TO CLEAN THE HYDRAULIC SUCTION STRAINER

Remove the hydraulic suction strainer after draining the hydraulic reservoir. The suction strainer is part of the filter assembly located on the side of the hydraulic reservoir. It can be removed from the reservoir for replacement.

1. Lift the seat deck to gain access to the suction strainer
2. Remove the hose connected to the suction strainer.
3. Turn the suction strainer counter clockwise to remove from the reservoir.
4. Use a compressed air line on the inside of the strainer to blow impurities out of the filter media. If a compressed air line is unavailable, use new FORD type "F" Automotive Transmission Fluid to flush the filter media.
5. Flush the interior of the hydraulic reservoir with clean fluid.
6. Apply sealant to threads of strainer and install.
7. Rotate strainer clockwise into the reservoir. Stop rotation when hand tight.
8. Install the hydraulic hose removed in step 2.
9. Apply sealant to threads of drain plug and install into the hydraulic tank and tighten.
10. Open the breather filler cap.
11. Fill reservoir with new FORD type "F" automotive transmission fluid. Initially fill the reservoir with 7 gallons of fluid. Run the machine a short period of time to allow air to escape from the system then recheck the fluid level in the sight gauge and add fluid as necessary.
12. Close the breather filler cap.
13. Close the seat deck and engine cover.

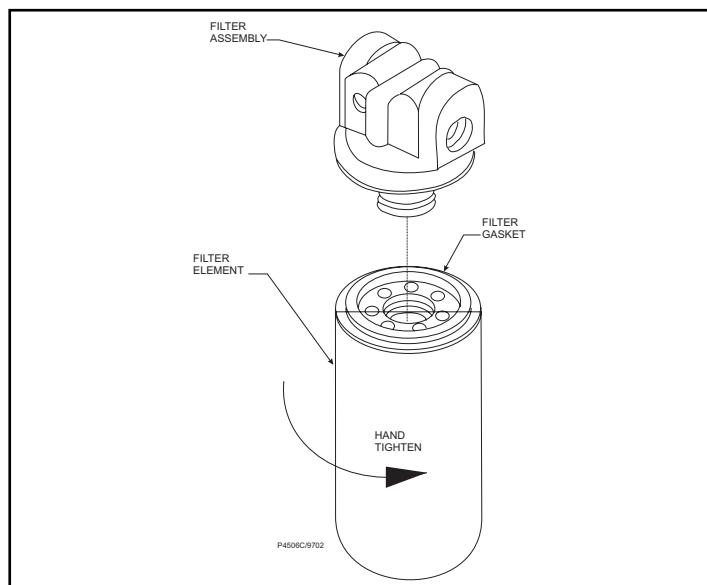

P4506C

FIGURE 37

TO REPLACE THE RETURN FILTER ELEMENT

Replace the return filter element after approximately 250 hours of machine run time.

1. Unscrew the filter element from the filter assembly and discard.
2. Moisten the filter gasket of a new filter element with hydraulic fluid.
3. Put filter element on the threaded nipple of the filter assembly.
4. Turn the filter clockwise until it is hand tight.
5. Wipe clean any hydraulic reservoir fluid spills.

NOTE

Monitor the air filter indicator daily

The importance of replacing the air filter at the appropriate time cannot be overemphasized. Even a small amount of dirt ingested through the air intake system will wear out a set of piston rings in just a few hours.

Always cover the air intake when removing the air filter for replacement. Keep all other air intake components, such as hoses and clamps, secure and in good condition to prevent intake of unfiltered air.

AIR FILTER

The elements contained within this air filter are **NOT** reusable. There is no interim cleaning involved other than a daily emptying of the dust collector housed in the filter cap. Squeeze and release the rubber valve on the filter cap several times to expel any dust or dirt that has accumulated. Replace **BOTH** the safety and main filter elements when the filter service indicator reaches the red band. The indicator will remain at the red band level even after the engine has been shut down. Reset the indicator by depressing the black button at the bottom.

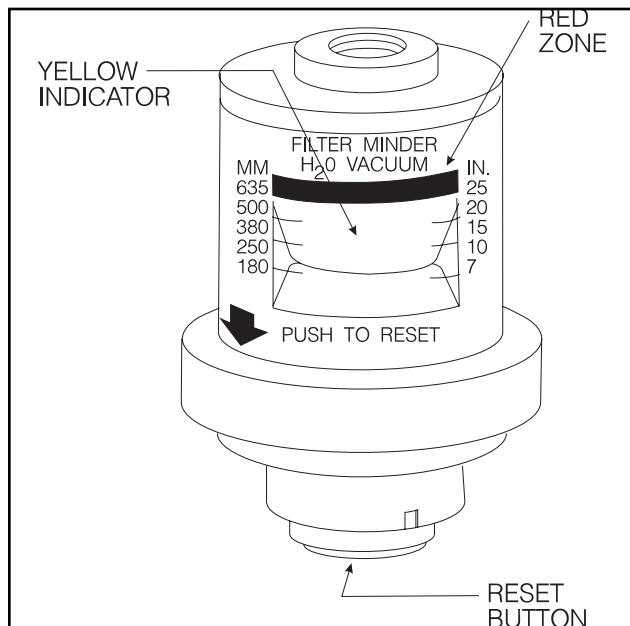

P4713

FIGURE 38a

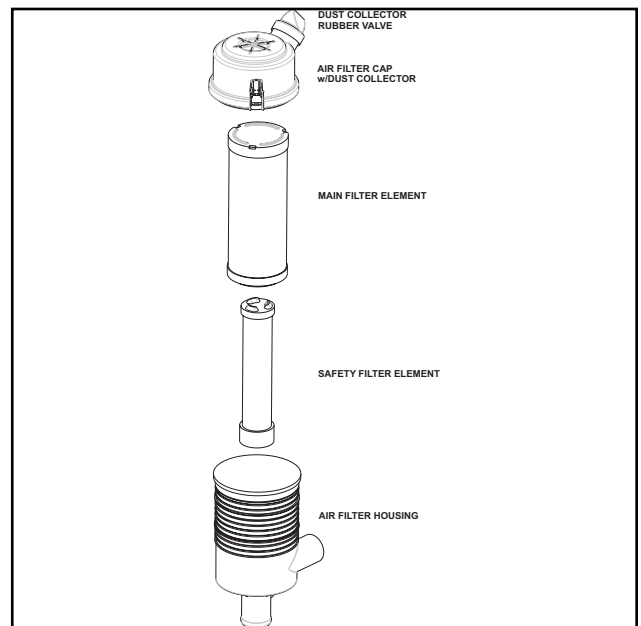

FIGURE 38b

TO REPLACE AIR FILTER ELEMENTS

1. Stop the engine and engage the machine parking brake.



WARNING

Always park on a level surface, stop the engine, and engage parking brake before working on the machine to keep it from creeping or rolling.

2. Unhook the two latches on the filter housing
3. Remove the cap
4. Clean dust collector (housed in cap) by squeezing and releasing the rubber valve several times
5. Remove both filter elements and discard
6. Insert new safety and main filter elements
7. Replace cap and close latches

SERVICE INSTRUCTIONS

ENGINE COOLING SYSTEM SERVICE

HOSES

Check all hoses and connections for leaks. Replace any of the hoses are cracked, frayed, or feel spongy.

RADIATOR

Inspect the exterior of the radiator daily for obstructions. Remove all bugs, dirt, or foreign material with a soft brush or cloth. Use care to avoid damaging the fins. If available, use compressed air or a stream of water in the opposite direction of normal air flow.



WARNING

Never remove the radiator cap under any conditions while the engine is operating. Failure to follow these instructions could result in damage to the cooling system or engine and/or personal injury. To avoid having scalding hot coolant or steam blow out of the radiator, use extreme care when removing the cap from a hot radiator. If possible, wait until the engine has cooled. Wrap a thick cloth around the radiator cap and turn it slowly to the first stop. Step back while pressure is released from the cooling system. When you are sure all pressure has been released, with a cloth, press down on the cap, turn and remove it.

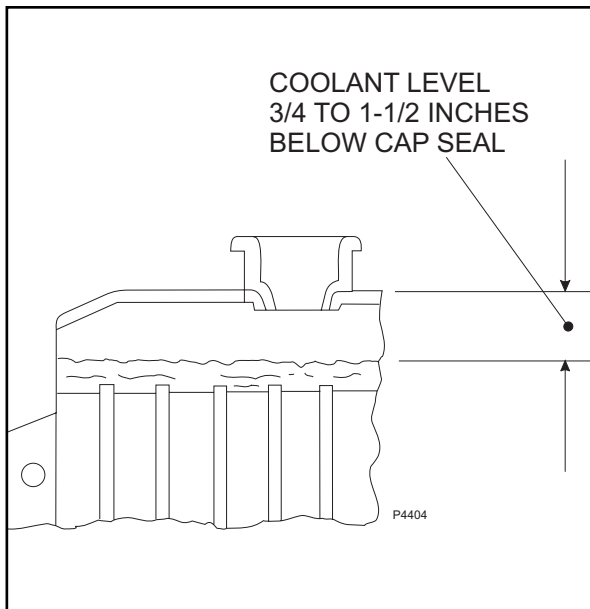

P-4404

FIGURE 39

COOLANT LEVEL

Check the coolant level in the radiator daily and only when the engine is cool. The coolant level should be maintained to approximately 3/4 inch (1.9 cm) below the filler neck seat on the radiator when the coolant is cold. Whenever coolant level checks are made, check the condition of the radiator cap rubber seal. Make sure it is clean and free of any dirt particles. Rinse off with clean water if necessary. When replacing the cap back on the radiator, make sure the radiator filler neck is clean and void of debris.

DRIVE BELTS

The drive belts should be properly adjusted at all times. A loose drive belt causes improper alternator, fan and water pump operation, and overheating. Overtightening the belt may result in excessive wear on the alternator and water pump bearings, as well as premature wear on the belt itself. It is recommended that proper belt tension be maintained and checked periodically.

BATTERY

The battery is located in the engine compartment. Keep the top of the battery clean and dry. Keep the terminals and connectors clean. To clean the tops of batteries, use a damp cloth with a weak solution of ammonia or bicarbonate of soda solution. To clean the terminals and connectors, use a terminal and connector cleaning tool.

ATTENTION

NEVER allow the soda solution to enter the cells. This will permanently discharge the battery.

LP SAFETY PRECAUTIONS



WARNING

Keep cigarettes, sparks, and open flame away when working on LP equipment. When inspecting for gas leaks or when LP tanks are present.



WARNING

Check all components for proper operation. Replace LP components when needed. Never by-pass defective safety components.



WARNING

Check routing of all LP hoses. Keep them away from sharp edges, exhaust manifolds, or other hot surfaces. Check for signs of abrasion or deterioration.



WARNING

Check for gas odor before and during starting operations.. If gas odor is noticed, stop and check for leaks or component malfunction.



WARNING

Make sure LP tank is free of dents or gouges.



WARNING

Make sure service coupling is clean and free of damage. Make sure service coupling of tank matches machine service coupling.



WARNING

Keep the engine properly tuned.



WARNING

Make sure the LP tank matches the fuel system.



WARNING

Make sure the LP tank is securely mounted on the machine with the retainer bracket clamping the tank and with the locating pin in position.



WARNING

Park the machine in a shaded, cool area when not in use.



WARNING

Keep the LP tank service valve closed when the tank is not in use.



WARNING

Never overfill the LP tank. Fill the LP tank to the recommended weight stamped on the tank.



WARNING

Use care in handling LP tanks. Never drop or drag them.



WARNING

Always store and transport LP fuel tanks with the safety relief valve in the "UP" position.



WARNING

Avoid contact with the LP fuel to avoid frostbite.



WARNING

When the machine is to stand unused for a period of time (overnight), park the machine in a designated area. Shut off the service valve at the tank and operate the engine until the remaining fuel is consumed. Turn off the ignition switch.

LP COMPONENTS

LP FUEL SYSTEM

The LP fuel system consists of several components not found on the gasoline system. The LP fuel system also contains the associated mounting hardware and plumbing for the LP components. The major LP components are as follows (these components are factory set, adjustments to these components should only be made by authorized service personnel):

1. Throttle plate & mixer
2. Combination water-heated vaporizer & regulator
3. Megajector
4. LP fuel tank, valves & fittings

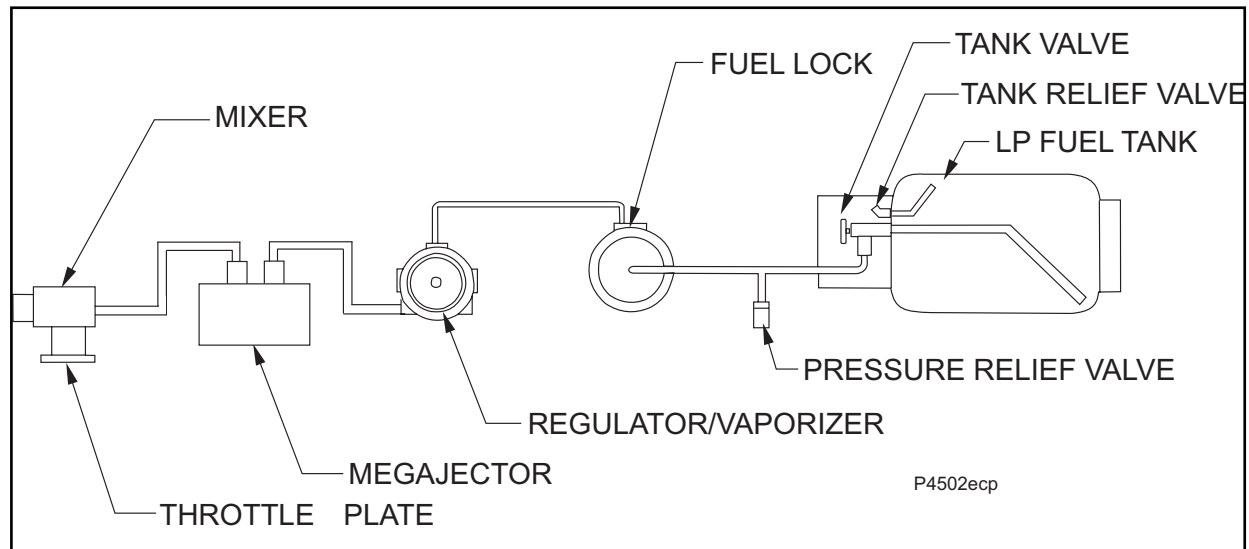

P-4502ecp

LP VAPOR WITHDRAWAL SYSTEM

The liquid fuel flows from the tank under its own pressure to the pressure relief valve. This valve is normally closed, which prevents fuel from escaping into the atmosphere. When the engine is running, LP then flows through the open fuel lock (lock automatically closes when engine is shut down) and into the vaporizer/regulator where it is converted to a gaseous state. (The regulator reduces the tank pressure and makes the flow more constant.) As the vaporized LP moves through the Megajector, the Megajector meters the amount of LP necessary to be piped into the mixer where it is then introduced into the air flow and sent to the combustion chamber.

LP CHECKLIST

This checklist can be performed quickly and should be done before every use. Be sure to make all necessary checks as listed on the Maintenance Chart as discussed earlier.

1. Check connections for leaks.
2. Open the LP storage tank valve.
3. Start the machine's engine.

LP VAPORIZER-REGULATOR QUICK CHECK

1. Turn the ignition switch on.
2. Open the radiator cap.
3. Check the coolant for bubbles. If bubbles are present, the vaporizer may have a leaking gasket or developed a pinhole leak allowing the LP fuel to enter the cooling system.

LP FUEL TANKS

Standard D.O.T. LP fuel tank sizes have 14, 20, 33.5, and 43.5 pounds capacities. The liquid volume permitted in these containers is less than the total volume of the cylinder. This provides for expansion of the LP fuel should be temperature increase above the normal amounts. Excessive heat may cause the fuel to expand too much causing the safety relief valve to vent some LP fuel, relieving internal tank pressure.

Each tank is marked showing the type of construction (liquid or vapor), the manufacturer, the date of manufacture, the capacity, the weight, and the date of re-qualification. D.O.T. fuel tanks must be re-qualified (checked) periodically. This re-qualification must be recorded and maintained for the life of the container.

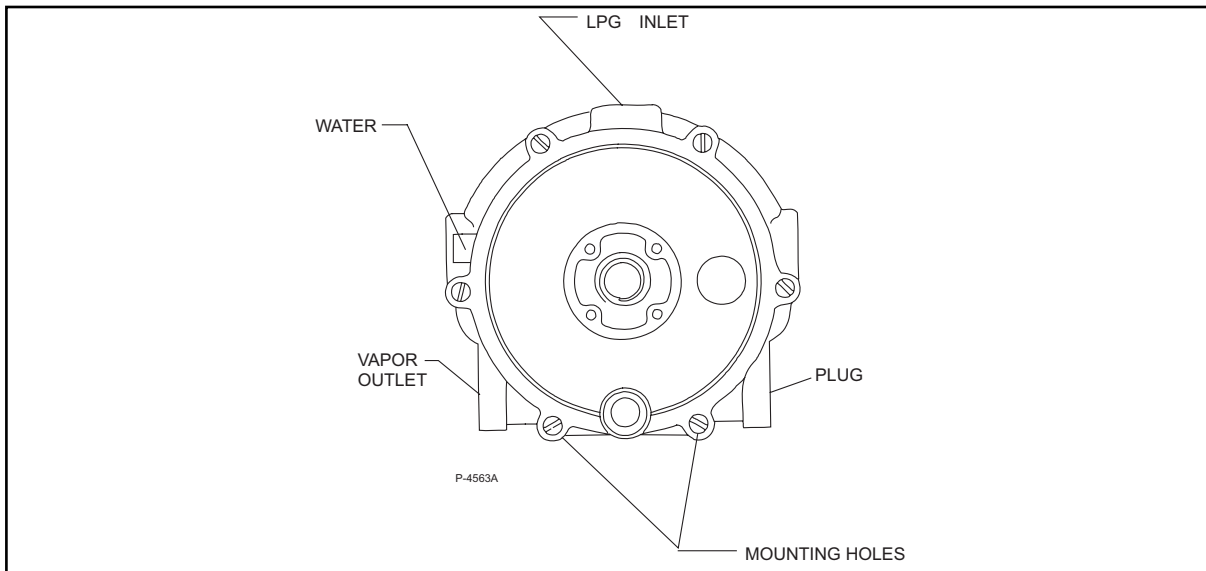

P-4563A

FIGURE 40

LP fuel tanks are equipped with the following approved valves and fittings:

Safety Relief Valve - This is a spring loaded valve that relieves excessive pressures which may develop in the tank due to unusual conditions.

Liquid Service Valve - Liquid is withdrawn from the tank through this valve. The LP tank may be filled through this valve if the tank is not equipped with a filler valve.

Excessive Flow Valve - This valve is part of the Liquid Service Valve. It is mounted inside the tank and prevents LP fuel from leaving the LP tank in the event of accidental breakage of external fittings or hoses. It permits flow in either direction but stops outward flow if that flow becomes excessive.

Filler Valve - This valve is optional. If this valve is not present, the tank is filled through the service valve.

Liquid Level Gauge - This gauge is optional.

USE AND CARE OF LP TANKS

If an LP tank is damaged or leaking, it should be immediately removed to a designated safe area and the proper personnel should be notified. Do not attempt to make repairs to the cylinder regardless of its conditions. Repairs must be made by qualified personnel.

The care of an LP tank receives has a direct bearing on how long the tank can be used safely. LP tanks must not be dropped, dragged, or slid across any surface. To move the LP tank, use a hand truck or roll the tank on its foot ring while it is being held in a position slightly off the vertical.

LP TANK CARE

CHANGING LP TANKS

Refueling machines with LP tanks is an important process. Refueling is accomplished by replacing the empty LP tank with a full one.

The tank changing operation presents an opportunity for the machine operator to carefully inspect the tank, tank fittings, the fuel lines and fuel line fittings. If abnormal wear is detected, the operator should report these findings to the appropriate personnel for immediate action.

TO BEGIN CHANGING THE LP TANK

- Park the machine in a designated safe area and set the parking brake.
- Close the tank valve.
- Remove the quick-disconnect coupling from the tank valve.
- Inspect the machine's fuel lines and the quick disconnect coupling for damage or abnormal wear.
- Remove the empty tank from the holding device.
- Inspect the tank and tank fittings for damage or abnormal wear. Handle the tank carefully. It must not be dropped or mishandled.
- Store the LP tank in a designated safe area.
- Select a filled LP tank and observe for damage or leaks.
- Carefully install the filled tank in the machine so that the tank centering pin enters the aligning hole in the tank collar. This assures that the tank is positioned properly and allows for proper operation of the safety relief valve, liquid level gauge, and service valves.
- Fasten the tank retaining bracket so that the tank is locked into position.
- Reconnect the fuel line to the tank servicing coupling.
- Open the service valve slowly and check for leaks. If a leak is found, close the valve immediately and notify the appropriate personnel.
- If no leaks are detected, the engine is ready to start. Do not start the engine unless the operator is in position with the directional control pedal in the neutral position.

STORAGE OF LP FUEL TANKS

Whether the storage is inside or outside, the LP tanks should not be in the vicinity of combustible materials or high temperature sources such as ovens or furnaces. This may cause the heat to raise the pressure of the fuel to a point where the safety relief valves would begin operation. Care should be taken to ensure that the cylinders are stored in such a manner that if the safety relief valves are triggered, the vapor will be relieved rather than any liquid.

Valves on empty tanks must be closed during storage and transportation.

Similar precautions should be taken in storing machines fitted with LP fuel tanks. They may be stored or serviced inside buildings provided there are no leaks in the fuel system and the tanks have not been overfilled. If machines are being repaired inside a building, the shutoff valve on the tanks must be closed except when the engine must be on during servicing.

TORQUE REQUIREMENTS

STANDARD METRIC TORQUE VALUES

When tightening torques are not specified, tighten the bolts and nuts according to the table below.

GRADE		No-Grade or 4T			7T			9T		
		SS41, S20C			S43C, S48C			SCR435, SCM435		
Nom. Dia.	Unit	N.m	kgf.m	ft-lbs	N.m	kgf.m	ft-lbs	N.m	kgf.m	ft-lbs
M6 (6mm, 0.24 in.)		7.85	0.80	5.79	9.81	1.00	7.23	12.26	1.25	9.04
		to	to	to	to	to	to	to	to	to
		9.32	0.95	6.87	11.28	1.15	8.32	14.22	1.45	10.49
M8 (8mm, 0.31 in.)		17.7	1.8	13.0	23.5	2.4	17.4	29.4	3.9	21.7
		to	to	to	to	to	to	to	to	to
		20.6	2.1	15.2	27.5	2.8	20.3	34.3	3.5	25.3
M10 (10mm, 0.39 in.)		39.2	4.0	28.9	48.1	4.9	35.4	60.8	6.2	44.8
		to	to	to	to	to	to	to	to	to
		45.1	4.6	33.3	55.9	5.7	41.2	70.6	7.2	52.1
M12 (12mm, 0.47 in.)		62.8	6.4	46.3	77.5	7.9	57.1	103.0	10.5	75.9
		to	to	to	to	to	to	to	to	to
		72.6	7.4	53.5	90.2	9.2	66.5	117.7	12.0	86.8

ENGINE TORQUE VALUES

Screws, bolts and nuts must be tightened to the specified torque using a torque wrench. Several screws, bolts, and nuts such as those used on the cylinder head must be tightened in proper sequence and at the proper torque.

ITEM	Size & Pitch	N.m	kgf.m	ft-lbs
*Head Cover Cap Nuts	M6 x 1.0	3.9 to 5.9	0.4 to 0.6	2.9 to 4.3
*Head Bolts	M8 x 1.25	37.2 to 42.1	3.8 to 4.3	28.9 to 32.5
*Bearing Case Bolts 1	M6 x 1.0	12.7 to 15.7	1.3 to 1.6	9.4 to 11.6
*Bearing Case Bolts 2	M7 x 1.0	26.5 to 30.4	2.7 to 3.1	19.6 to 22.5
*Flywheel Bolts	M10 x 1.25	53.9 to 58.8	5.5 to 6.0	39.8 to 43.4
*Connecting Rod Bolts	M6 x 0.75	26.5 to 30.4	2.7 to 3.1	10.8 to 13.7
*Rocker Arm Bracket Bolts	M6 x 1.0	9.81 to 11.28	1.00 to 1.15	7.23 to 8.32
*Idler Gear Shaft Bolts	M6 x 1.0	9.81 to 11.28	1.00 to 1.15	7.23 to 8.32
Spark Plugs	M14 x 1.25	19.6 to 24.5	2.0 to 2.5	14.5 to 18.1
Drain Plugs	M12 x 1.25	32.4 to 37.3	3.3 to 3.8	23.9 to 27.5
Oil Switch Taper Bolt	PT 1/8	14.7 to 19.6	1.5 to 2.0	10.8 to 14.5
*Crankshaft Bolt	M12 x 1.5	98.1 to 107.9	10.0 to 11.0	72.3 to 79.6

For "*" marked bolts and nuts in the table, apply engine oil to their threads and seats before tightening.

Screw and bolt material grades are shown by numbers punched on the screw and bolt heads.

C-2005

HYDRAULIC TORQUE REQUIREMENTS

HYDRAULIC TORQUE REQUIREMENTS

Refer to the following chart for torque values on all hydraulic hoses and fittings.

Nominal SAE Dash Size	O-Ring Face Seal End		SAE O-Ring Boss End	
	Thread Size Inch	Swivel Nut Torque	Thread Size Inch	Str. Fitting or Locknut Torque
		LB-FT		LB-FT
-3	*	*	3/8-24	8-10
-4	9/16-18	10-12	7-16-20	14-16
-5	*	*	1/2-20	18-20
-6	11/16-16	18-20	9/16-18	24-25
-8	13/16-16	32-35	3/4-16	50-60
-10	1-14	46-50	7/8-14	72-80
-12	1 3/16-12	65-70	1 1/16-12	125-135
-14	1 3/16-12	65-70	1 3/16-12	160-180
-16	1 7/16-12	92-100	1 5/16-12	200-220
-20	1 11/16-12	125-140	1 5/8-12	210-280
-24	2-12	150-165	1 7/8-12	270-360

* O-Ring face seal type end not defined for this tube size.

NOTE

Parts must be lightly oiled with hydraulic fluid.

C-2002

STANDARD HARDWARE & TORQUE REQUIREMENTS

BOLT IDENTIFICATION

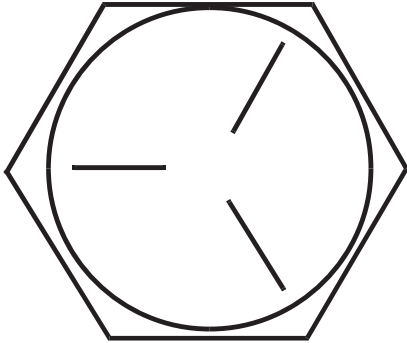

SAE - Grade 5

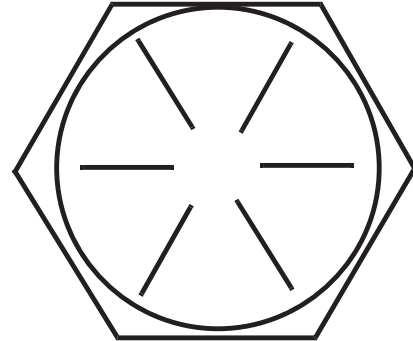

SAE - Grade 8

Screw Size	Grade 5 Plated		Grade 8 Plated		410H Stainless		Brass	Type F & T & BT		Type B, AB
	C	F	C	F	C	F		C	F	
*6	14	15	-	-	18	20	5	20	23	21
*8	27	28	-	-	33	35	9	37	41	34
*10	39	43	-	-	47	54	13	49	64	49
*1/4	86	108	130	151	114	132	32	120	156	120
5/16	15	17	22	24	19	22	6	-	-	-
3/8	28	31	40	44	34	39	10	-	-	-
7/16	44	49	63	70	55	62	16	-	-	-
1/2	68	76	95	108	85	95	-	-	-	-
9/16	98	110	138	155	-	-	-	-	-	-
5/8	135	153	191	216	-	-	-	-	-	-
3/4	239	267	338	378	-	-	-	-	-	-
7/8	387	-	545	-	-	-	-	-	-	-
1	579	-	818	-	-	-	-	-	-	-

C = Coarse Thread

F = Fine Thread

* = Torque values for #6 through 1/4 are lb./in. All others are lb./ft.

NOTE

Decrease the torque by 20% when using thread lubricant
The torque tolerance is \pm on torque values.

+

C2000/9905

DECIMAL METRIC CONVERSION TABLE

FRACTION	DECIMAL	MILLIMETER	FRACTION	DECIMAL	MILLIMETER
$\frac{1}{64}$	0.015625	0.3969	$\frac{33}{64}$	0.515625	13.0969
$\frac{1}{32}$	0.03125	0.7938	$\frac{17}{32}$	0.53125	13.4938
$\frac{3}{64}$	0.046875	1.1906	$\frac{35}{64}$	0.546875	13.8906
$\frac{1}{16}$	0.0625	1.5875	$\frac{9}{16}$	0.5625	14.2875
$\frac{5}{64}$	0.078125	1.9844	$\frac{37}{64}$	0.578125	14.6844
$\frac{3}{32}$	0.09375	2.3813	$\frac{19}{32}$	0.59375	15.0813
$\frac{7}{64}$	0.109375	2.7781	$\frac{39}{64}$	0.609375	15.4781
$\frac{1}{8}$	0.125	3.1750	$\frac{5}{8}$	0.625	15.8750
$\frac{9}{64}$	0.140625	3.5719	$\frac{41}{64}$	0.640625	16.2719
$\frac{5}{32}$	0.15625	3.9688	$\frac{21}{32}$	0.65625	16.6688
$\frac{11}{64}$	0.171875	4.3656	$\frac{43}{64}$	0.671875	17.0656
$\frac{3}{16}$	0.1875	4.7625	$\frac{11}{16}$	0.6875	17.4625
$\frac{13}{64}$	0.203125	5.1594	$\frac{45}{64}$	0.703125	17.8594
$\frac{7}{32}$	0.21875	5.5563	$\frac{23}{32}$	0.71875	18.2563
$\frac{15}{64}$	0.234375	5.9531	$\frac{47}{64}$	0.734375	18.6531
$\frac{1}{4}$	0.25	6.3500	$\frac{3}{4}$	0.75	19.0500
$\frac{17}{64}$	0.265625	6.7469	$\frac{49}{64}$	0.765625	19.4469
$\frac{9}{32}$	0.28125	7.1438	$\frac{25}{32}$	0.78125	19.8438
$\frac{19}{64}$	0.296875	7.5406	$\frac{51}{64}$	0.796875	20.2406
$\frac{5}{16}$	0.3125	7.9375	$\frac{13}{16}$	0.8125	20.6375
$\frac{21}{64}$	0.328125	8.3344	$\frac{53}{64}$	0.828125	21.0344
$\frac{11}{32}$	0.34375	8.7313	$\frac{27}{32}$	0.84375	21.4313
$\frac{23}{64}$	0.359375	9.1281	$\frac{55}{64}$	0.859375	21.8281
$\frac{3}{8}$	0.375	9.5250	$\frac{7}{8}$	0.875	22.2250
$\frac{25}{64}$	0.390625	9.9219	$\frac{57}{64}$	0.890625	22.6219
$\frac{13}{32}$	0.40625	10.3188	$\frac{29}{32}$	0.90625	23.0188
$\frac{27}{64}$	0.421875	10.7156	$\frac{59}{64}$	0.921875	23.4156
$\frac{7}{16}$	0.4375	11.1125	$\frac{15}{16}$	0.9375	23.8125
$\frac{29}{64}$	0.453125	11.5094	$\frac{61}{64}$	0.953125	24.2094
$\frac{15}{32}$	0.46875	11.9063	$\frac{31}{32}$	0.96875	24.6063
$\frac{31}{64}$	0.484375	12.3031	$\frac{63}{64}$	0.984375	25.0031
$\frac{1}{2}$	0.5	12.7000	1	1.0000	25.4000

ABBREVIATIONS - SCREWS

ADJ	= Adjusting Screw
ADJ.SP	= Adjusting Plunger Screw
BHM	= Binding Head Machine Screw
BHS	= Button Head Socket Screw
CAPT.SL	= Captivated Slotted Screw
CAPT.WG	= Captivated Wing Screw
FHM	= Flat Head Machine Screw
FIL.HM	= Filister Head Machine Screw
HHC	= Hexagon Head Cap Screw
HHM	= Hexagon Head Machine Screw
HIHD	= 1/2 High Head Screw
HSHC	= Hexagonal Socket Head Cap Screw
HSFHC	= Hexagonal Socket Flat Head Cap Screw
KNH	= Knurled Head Screw
MHHC	= Metric Hexagon Head Cap Screw
PHM	= Pan Head Machine Screw
RHD	= Round Head Drive Screw
RHM	= Round Head Machine Screw
RHW	= Round Head Wood Screw
SHC	= Shiny Crown Cap Screw
SHTB	= Shoulder Thumb Screw
SQ	= Square Head Screw
TB	= Thumb Screw
THM	= Truss Head Machine Screw
WELD	= Weld Stud
WG	= Wing Screw

ABBREVIATIONS - SETSCREWS

HS	= Hexagonal Socket Setscrew
S	= Slotted Setscrew
SH	= Square Head Setscrew
-KCP	= Knurled Cup Point Setscrew
-CP	= Cup Point Setscrew
-OP	= Oval Point Setscrew
-FDP	= Full Dog Point Setscrew
-HDP	= Half Dog Point Setscrew
-FP	= Flat Point Setscrew
-COP	= Cone Point Setscrew

HARDWARE LEGEND

<u>Key No.</u>	<u>Part Number</u>	<u>Description</u>
H1	2-00-05060	Screw, #6-32 x 1.250 RHM
H2	2-00-00455	Flat Washer, .375 x .156 x .047
H3	2-00-01499	Lock Washer, #6 Med. Helical Spring
H4	2-00-00624	Nut, #6-32 Hex
H5	2-00-00645	Nut, Hex Fiber Insert #6-32
H6	2-00-00049	Screw, # 10-24 x .500 RHM
H7	2-00-00056	Screw, # 10-24 x .750 RHM
H8	2-00-00039	Screw, 10-24 x 1.000 RHM
H9	2-00-00426	Flat Washer, .500 x .219 x .063
H10	2-00-00519	Lock Washer, # 10 Med HS
H11	2-00-00605	Nut, Hex MS # 10-24 x .375 x .125
H12	2-00-01246	Nut, Hex Fiber Insert #10-24
H13	2-00-00054	Screw, 1/4-20 x .500 RHM
H14	2-00-00219	Screw, 1/4-20 x .500 HHC
H15	2-00-00221	Screw, 1/4-20 x .750 HHC
H16	2-00-03051	Screw, 1/4-20 x .750 HSHC
H17	2-00-00205	Screw, 1/4-20 x 1.000 HHC
H18	2-00-00060	Screw, 1/4-20 x 1.250 RHM
H19	2-00-02587	Screw, 1/4-20 x 1.250 HHC
H20	2-00-00203	Screw, 1/4-20 x 1.500 HHC
H21	2-00-01769	Screw, 1/4-20 x 1.750 HHC
H22	2-00-02589	Screw, 1/4-20 x 2.000 HHC
H23	2-00-01980	Screw, 1/4-20 x 2.500 HHC
H24	2-00-00220	Screw, 1/4-20 x .625 HHC
H25	2-00-00594	Nut, Hex 1/4-20 x .437 x .218
H26	2-00-00641	Nut, 1/4-20 Insert Fiber
H27	2-00-03702	Washer, .625 x .281 x .063
H28	2-00-04685	Screw, 1/4-20 x .750 HHC
H29	2-00-04966	Screw, 1/4-20 x 1.500 HHM
H30	2-00-04687	Lock Washer, Hel. Spring 1/4 Med.
H31	2-00-04695	Screw, # 10-32 x .630 RHM
H32	2-00-04688	Nut, 1/4-20 Hex.
H33	2-00-00224	Screw, 5/16-18 x .500 HHC
H34	2-00-00208	Screw, 5/16-18 x .750 HHC
H35	2-00-02708	Screw, 5/16-18 x 1.000 HHM
H36	2-00-00196	Carriage Bolt, 5/16-18 x 1.000
H37	2-00-00207	Screw, 5/16-18 x 1.250 HHC
H38	2-00-00225	Screw, 5/16-18 x 1.500 HHC
H39	2-00-00218	Screw, 5/16-18 x 2.000 HHC
H40	2-00-01770	Screw, 5/16-18 x 2.750 HHC
H41	2-00-02597	Screw, 5/16-18 x 3.250 HHC
H42	2-00-02655	Screw, 5/16-18 x 4.500 HHC
H43	2-00-00409	Flat Washer, .687 x .344 x .062
H44	2-00-00530	Lock Washer, 5/16 HS Med.
H45	2-00-00585	Nut, Hex. 5/16-18 x .500 x .265
H46	2-00-00644	Nut, 5/16-18, Insert Fiber
H47	2-00-00232	Screw, 3/8-16 x .750 HHC
H48	2-00-00233	Screw, 3/8-16 x 1.000 HHC
H49	2-00-00209	Screw, 3/8-16 x 1.250 HHC
H50	2-00-00234	Screw, 3/8-16 x 1.500 HHC
H51	2-00-00216	Screw, 3/8-16 x 2.000 HHC
H52	2-00-00402	Flat Washer, .750 x .390 x .094
H53	2-00-02310	Lock Washer, Helical Spring 3/8
H54	2-00-02360	Nut, 3/8-16 Hex.
H55	2-00-00643	Nut, 3/8-16 Stop

HARDWARE LEGEND

<u>Key No.</u>	<u>Part Number</u>	<u>Description</u>
H56	2-00-00239	Screw, 1/2-13 x 1.000 HHC
H57	2-00-00240	Screw, 1/2-13 x 1.250 HHC
H58	2-00-00241	Screw, 1/2-13 x 1.750 HHC
H59	2-00-00242	Screw, 1/2-13 x 2.250 HHC
H60	2-00-02682	Screw, 1/2-13 x 2.750 HHC
H61	2-00-02616	Screw, 1/2-13 x 3.000 HHC
H62	2-00-00405	Flat Washer, 1.063 x .531 x .094
H63	2-00-02312	Lock Washer, 1/2 HS Med.
H64	2-00-00596	Nut, Hex. 1/2-13 x .750 x .437
H65	2-00-04936	Nut, 1/2-13 Fibre Lock
H66	2-00-02689	Screw, 1/2-20 x 1.000 HHC
H67	2-00-00614	Nut, Hex 1/2-20
H68	2-00-00640	Nut, Hex Fiber Insert 1/2-20
H69	2-00-01255	Screw, 5/16-18 x .875 HHC
H70	2-00-05254	Screw, 3/4-10 x 2.250 HHC
H71	2-00-05255	Nut, 3/4-10 Nylon Lock
H72	2-00-00518	Lock Washer, Helical Spring
H73	2-00-00247	Screw, 1/2-13 x 2.500 HHC
H74	2-00-03170	Flat Washer, 1.500 x .750 x .125
H75	2-00-00618	Nut, Hex Jam 3/8-16
H76	2-00-00632	Nut, Fiber Insert 3/8-24 Steel
H77	2-00-00484	Flat Washer, .625 x .375 x .046
H78	2-00-05187	Carriage Bolt, 3/8-16 x 1.250
H79	2-00-01676	Flat Washer, 1.062 x .265 x .062'
H80	2-00-02196	Carriage Bolt, 1/4-20 x 1.000 RHM
H81	2-00-05276	Screw, 3/8-16 x 5.500
H82	2-00-00505	Lock Washer, 3/8 Int. Tooth
H83	2-00-04877	Screw, 1/4-20 x 1.000 BHS
H84	2-00-00228	Screw, 5/16-18 x 2.250 HHC
H85	2-00-00650	Nut, Cap 3/8-16 Low Crown
H86	2-00-03575	Carriage Bolt, 1/4-20 x .750
H87	2-00-00263	Set Screw, 1/4-20 x .250 HSKCP
H88	2-00-05258	Screw, #8-325 x .750 BHS
H89	2-00-01372	Nut, Fiber Insert #8-32 Steel
H90	2-00-03569	Carriage Bolt, 5/16-18 x .750
H91	2-00-05279	Screw, M6 x 1.0 x 20 mm MHHC
H92	2-00-04801	Flat Washer, .875 x .375 x .125
H93	2-00-00222	Screw, 1/4-20 x 1.250 HHM
H94	2-00-00410	Flat Washer, .875 x .375 x .060
H95	2-00-03382	Spring Washer, .875 x .500 x .015
H96	2-00-02605	Screw, 3/8-16 x 4.500 HHC
H97	2-00-04677	Screw, 1/4-20 x .750 HSC
H98	2-00-05277	Screw, 1/2-13 x .750 HSHC
H99	2-00-02810	Screw, 1/4-20 x 1.000 FHM
H100	2-00-03062	Screw, #10-24 x .625 THM
H101	2-00-04897	Screw, #10-24 x 1.250 THM
H102	2-00-04795	Screw, #10-24 x .750 BHS
H103	2-00-00089	Screw, 10-24 x 1.500 RHM
H104	2-00-03541	Screw, 1/4-20 x 1.500 FHSC
H105	2-00-05260	Nut, Jam #8-32
H106	2-00-04886	Screw, 3/8-16 x .500 HSHC
H107	2-00-04887	Screw, Main Broom Control
H108	2-00-04888	Washer, Main Broom Control
H109	2-00-00522	Lock Washer, 3/4 Helical Spring
H110	2-00-03039	Screw, 1/4-20 x .625 HSHC
H111	2-00-03296	Screw, 3/8-16 x 4.000 HHC

HARDWARE LEGEND

<u>Key No.</u>	<u>Part Number</u>	<u>Description</u>
H112	2-00-02603	Screw, 3/8-16 x 3.500 HHC
H113	2-00-03333	Screw, 3/8-16 x 3.750 HHC
H114	2-00-00633	Nut, Fiber 1/4-28
H115	2-00-03063	Screw, #10-24 x .750 THM
H116	2-00-01951	Carriage Bolt, 1/4-20 x 1.250
H117	2-00-05067	Flat Washer, 1.750 x .531 x .100
H118	2-00-02618	Screw, 1/2-13 x 3.500 HHC
H119	2-00-05005	Screw, M10 x 1.500 30 mm MHHC
H120	2-00-03829	Lock Washer, 3/8 Bolt
H121	2-00-00090	Screw, #8-32 x 1.500 RHM
H122	2-00-05216	Screw, 1/4-20 x 5.000 HHC
H123	2-00-00204	Screw, 1/4-20 x 1.500 HHC
H124	2-00-02296	Lock Washer, #10 Ext. Shakeproof
H125	2-00-00418	Flat Washer, .984 x .627 x .063
H126	2-00-03466	Screw, #10-16 x .500
H127	2-00-03522	Washer, 5/16 x 1.250 x .050
H128	2-00-04681	Carriage Bolt, 5/16-18 x 1.250
H129	2-00-02311	Lock Washer, 4.38 Split
H130	2-00-03334	Screw, .44-20 x 1.000 HHC
H131	2-00-03855	Carriage Bolt, 3/8-16 x 1.000
H132	2-00-00503	Lock Washer, 1/4 Ext.
H133	2-00-00006	Screw, #10-24 x .675 FHM
H134	2-00-03032	Screw, 3/8-16 x .750 FHS
H135	2-00-05298	Flat Washer, .344 x 2.000 x .062
H136	2-00-03940	Screw, #10-24 x .500 T/C HH
H137	2-00-05299	Screw, #10-24 x 1.250 HSHC
H138	2-00-00504	Lock Washer, Int.
H139	2-00-00611	Nut, Hex Jam, 3/8-24
H140	2-00-00447	Flat Washer, 1.250 x .280 x .090
H141	2-00-00501	Lock Washer, Int.
H142	2-00-05244	Carriage Bolt, 1/2-13 x 2.000
H143	2-00-00432	Flat Washer, 1.13 x .770 x .063
H144	2-00-02303	Lock Washer, Int.
H145	2-00-04180	Setscrew, 1/4-20 x .500
H146	2-00-00420	Flat Washer, 1.000 x .516 x .063
H147	2-00-00642	Nut, Fibre Insert 5/18-18
H148	2-00-01778	Screw, 1/2-13 x 2.000 HHC
H149	2-00-01803	Washer, 1.063 x .031 x .063
H150	2-00-00211	Screw, 5/16-18 x 1.750 HHC
H151	2-00-00213	Screw, 5/16-18 x .625 HHC
H152	2-00-01562	Carriage Bolt, 5/16-18 x 2.250
H153	2-00-03266	Washer
H154	2-00-04363	Screw, M8-1.250 x .750
H155	2-00-05044	Lock Washer, M14 Split
H156	2-00-05079	Screw, M14 x 1.500 x 25 mm HHC
H157	2-00-00217	Screw, 5/16-18 x 2.000 HHC
H158	2-00-05306	Screw, M14 x 35 mm HHC
H159	2-00-00512	Lock Washer
H160	2-00-00441	Flat Washer, .438 x .200 x .036
H161	2-00-00153	Screw, #8-24 x .875 OHM
H162	2-00-03961	Screw, 5/16-24 x 1.000 HHC
H163	2-00-03570	Carriage Bolt, 3/8-16 x .750
H164	2-00-00107	Screw, 10-24 x 4.50 RD. HD.
H165	2-00-00589	Nut, Hex Jam, .25-20
H166	2-00-00066	Screw, 6-32 x .50 RHM
H167	2-00-04312	Screw, 10-24 x .625 T/C Hex HD.

HARDWARE LEGEND

<u>Key No.</u>	<u>Part Number</u>	<u>Description</u>
H168	2-00-05261	Insert, 1/4-20
H169	2-00-02637	Screw, 1/4-20 x 2.750 HHC
H170	2-00-03061	Screw, # 10-24 x .500 THM
H171	2-00-02371	Nut, Hex Jam .50-13 STL.
H172	2-00-04986	Screw, 1/4-20 x 4.500
H173	2-00-02709	Screw, 5/16-18 x 1.500
H174	2-00-00183	Screw, 1/4-20 x .750 THM
H175	2-00-01252	Screw, 10-24 x 2.750 RDH
H176	2-00-05337	Screw, #8-32 x .750 BHS SS
H177	2-00-05324	Threaded Insert, #8-32
H178	2-00-00206	Screw, 5/16-18 x 1.000 HHC
H179	2-00-04948	Screw, 25mm - M8 x 1.250
H180	2-00-04378	Clip, Water Line
H181	2-00-05078	Screw, M6 x 1.000 x 10mm HHC
H182	2-00-00236	Screw, 5/8-16 x 2.500 HHC
H183	2-00-05042	Lock Washer, M10
H184	2-00-04366	Screw, M10 x 1.500 x 25mm
H185	2-00-02588	Screw, 1/4-20 x 1.125 HHC Cad. Pl.
H186	2-00-03041	Screw, 1/4 x 1.250 HSC-SS
H187	2-00-00071	Screw, #10-24 x 1.250 RHM
H188	2-00-01987	Flat Washer, .438 x .200 x .036 sst
H189	2-00-00460	Flat Washer, .437 x .192 x .031-s
H190	2-00-00529	Lock Washer - helical sps, 8 MDM
H191	2-00-00602	Nut, MSCR - Hex, 8-32
H192	2-00-04841	Nut 3/4 - 16 Slotted Hex head
H193	2-00-03412	Lock Nut, .375 - 24, sps 21 FK
H194	2-00-03537	Screw - 1/4 - 20 x2.000
H195	2-00-04210	Clamp
H196	2-00-05350	Screw 1/4 - 28 x .63 HHC
H197	2-00-03979	Washer 1.00 x .391 x .06
H198	2-00-03808	Washer 1.50 x .750 x .06
H199	2-00-04603	Clamp
H200	2-00-00626	Nut, Hex MS #10 - 32 x .375 x .125
H201	2-00-02011	Plastic Plug, .440 Dia (Diesel)
H202	2-00-04514	Plastic Plug, .562 Dia (LP & Gas)
H203	2-00-04794	Screw, #10 - 24 x .625 BHS
H204	2-00-04873	Clamp
H205	2-00-04721	Grommet, 1.750 x1.125 x .500 x.125
H206	2-00-00407	Washer, Flat .562 x.265
H207	2-00-02227	Key, .125 x .750 SQ
H208	2-00-00772	Cotterpin .093 x 1.000
H209	2-00-00586	Nut Hex Jam 5/16 - 18x .500 x .187
H210	2-00-00776	Cotterpin .125x1.500
H211	2-00-02728	Screw 10 - 32 x .375 BHM
H212	2-00-00566	Fitting-Grease
H213	2-00-01254	Screw - 1/2 - 13 x 1.500 HHCS
H214	2-00-00462	Flat Washer, .562 x .250 x .031
H215	2-00-02558	Grease Zerk
H216	2-00-04378	Harness Clamp
H217	2-00-00511	Internal Washer, #6
H218	2-00-05345	Screw, Hex Head Cap
H219	2-00-05359	Nut, Serrated Flange 5/16-18
H220	2-00-02617	Screw, 50-13 x 3.25 HHC
H221	2-00-03335	Screw, Hex SOC Cap, .312 -18 x .50
H222	2-00-02848	Screw, 10-32 x .50 Cad PL,STL RHM
H223	2-00-00631	Nut, .31 - 24 Fiber Insert

HARDWARE LEGEND

<u>Key No.</u>	<u>Part Number</u>	<u>Description</u>
H224	2-00-04686	Lock Washer-helical#10Scr.Med. SS
H225	2-00-04851	Washer, Engine Mount
H226	2-00-04689	Washer, 11/16 OD x .260 ID x .050
H227	2-00-04596	Screw, Hex Head 1/4 - 20 x 3.5
H228	2-00-02606	Screw, .375 - 24 x 1.00, STL HHC
H229	2-00-01490	Screw, .25 - 20 x .875 HHC STL
H230	2-00-00466	Flat Washer, .625 x .203 x .031
H231	2-00-02933	Screw, Mach 10 - 24 x 3.50
H232	2-00-04909	Yoke, Pin Assy.
H233	2-00-02638	Screw, HHC .25-20 x 3.00
H234	2-00-00064	Screw- RHM #10-24 x .88
H235	2-00-00197	Carriage Bolt, .38-16 x 2.75
H236	2-00-02369	Nut, Hex Jam, .38-16
H237	2-00-05356	Screw, 5/16 - 18 X 1.25 Grade 8
H238	2-00-03750	Carriage Bolt, .38-16 x 1.50
H239	2-00-02814	Screw-FHM .25-20x1.75
H240	2-00-05398	Screw, HSHC 3/8-16 x .50
H241	2-00-05395	Screw, RHM .25-20 x 4.00 Zinc
H242	2-00-05370	Screw, M12 - 16 x 1.75 x 40mm HHC
H243	2-00-00591	Nut, Hex-Jam .50-20
H244	2-00-05297	Nut, Insert Fiber, .38-16 Heavy Nut
H245	2-00-05401	Shoulder Screw, 1/2-3/4
H246	2-00-05122	Screw-HHC, .25-20 x 2.00
H247	2-00-04590	Washer
H248	2-00-05236	Flat Washer, 2.000 x .281 x .063
H249	2-00-00004	Screw-FHM #10-24 x 1.25
H250	2-00-04968	Screw-T/FRH #14-10 x 1.00 Type A
H251	2-00-02602	Screw, 3/8-16 x 2.750 HHC Cad. PI
H252	2-00-00600	Nut, Hex Heavy 3/8-16
H253	2-00-05120	Nut, .75-Hex Nyloc Jam
H254	2-00-04625	Screw-HHM .375-24 x .75
H255	2-00-00227	Screw-HHC .313-18 x 2.25
H256	2-00-02354	Nut-Hex-Jam .50-20
H257	2-00-00093	Screw-RHM 6-32 x .75
H258	2-00-04062	Screw-T/FFH #6-20 x .50
H259	2-00-05343	Bolt Carriage , .38-16 x 3.50 sstl
H260	2-00-00615	Nut, Hex Fin .63 - 22
H261	2-00-05344	Screw - HHM .313 - 18 x 1.75 Stl
H262	2-00-00617	Nut, Hex, Finish .75-16
H263	2-00-02313	Lock Washer, HS .63 Scr. Med.
H264	2-00-02622	Screw, 5/16 - 18 x 1.000 HHM
H265	2-00-00506	Lock Washer, Int Tooth #8 Dia Screw
H266	2-00-05371	Screw-RHM #8-32 x 2.38
H267	2-00-00068	Screw-RHM #8-32 x .63
H268	2-00-00051	Screw-RH, .25 - 20 x .75
H269	2-00-00118	Screw - RHM #10 - 24 x .625
H270	2-00-05341	Screw-HHC .75-10 x 2.00
H271	2-00-03293	Nut-Hex-Fin .75-10
H272	2-00-04563	Screw, Shoulder #10-24
H273	2-00-03214	Screw, .31-18 x .75 Zinc PL HSHC
H274	2-00-02676	Screw, .50 - 13 x .75 HHM
H275	2-00-00237	Screw, HHC .375 - 16 x 3.00
H276	2-00-00223	Screw, HHC .25-20 x 1.25 nickel
H277	2-00-05164	Screw, HHM 5/16 - 18 x 3.50
H278	2-00-03044	Screw, .38 -16 .75 HSHC
H279	2-00-04914	Screw, .50 - 13 x 4.50 HHC

HARDWARE LEGEND

<u>Key No.</u>	<u>Part Number</u>	<u>Description</u>
H280	2-00-00187	Bolt Carriage, .38 - 16 x 2.50
H281	2-00-00415	Flat Washer, .9375 x .468 x .0625SS
H282	2-00-02562	Fitting
H283	2-00-03842	Roll Pin, 1/4 x 1.00
H284	2-00-04845	Screw, 3/8-16 x 1.00 FHSC
H285	2-00-05153	Screw, 1/4 x 20 1.50 HHC
H286	2-00-05383	Washer, Special
H287	2-00-00264	Set Screw, 1/4-20 x .313 HSKCP
H288	2-00-00668	Wing Nut, 5/16-18
H289	2-00-00532	Snap Ring
H290	2-00-02049	Bearing - Double Seal
H291	2-00-02243	Square Key, .188 - .187 x 1.250
H292	2-00-02293	Lockwasher, 5/8 Int.
H293	2-00-03151	Spacer, 1/2 ID 3/4 .625 Lg.
H294	2-00-03158	Spacer, 1/2 ID 3/4 .3/8 Lg.
H295	2-00-03306	Bearing
H296	2-00-03413	Flat Washer, 1.125 x .765 x .062
H297	2-00-04345	Tye - Wrap
H298	2-00-04708	Terminal
H299	2-00-05183	Terminal, 1/4 x .03 12-10
H300	2-00-00767	Cotter Pin, .063 x.500
H301	2-00-04159	Flat Washer, 1.375 x .563 x .109 SS
H302	2-00-00490	Washer, Spring, Shakeproof
H303	2-00-05103	Flat Washer, .750 x .343 x .050 SS
H304	2-00-00246	Screw, .25 - 20 x 2.25 HHC
H305	2-00-00809	Screw, HSHC .31 - 18 x 1.00
H306	2-00-05405	Nut, 3/8 - 32 NEF 2A
H307	2-00-02963	Screw, RHM #10-32 1/4 PL. (Steel)
H308	2-00-05388	Sealing Washer 46/53 ESP OPT
H309	2-00-01081	Screw - T/C RH #8-32x.50type 2
H311	2-00-05024	Washer Flat, 2 x 1.06
H312	2-00-05227	Screw, HHC M14 x 1.50 x 45mmgr10
H313	2-00-04652	Screw, HHC .438 - 20 x 1.50
H314	2-00-03836	Bolt Carriage, .31 - 18 x 1.75
H315	2-00-00593	Nut, .38-16 Hex heavy Jam
H316	2-00-00044	Screw, RHM #8-32 x .50
H317	2-00-00252	Screw, .313-18 x 4.00 HHC
H318	2-00-04750	Screw, BTN HD SKT
H319	2-00-02352	Nut, Hex Hvy, .50-13 stl-zn.
H320	2-00-05424	Screw, Shoulder 1/2-1/2
H321	2-00-04699	Screw, HHC, .375-16 x 2.75
H322	2-00-03993	Screw, HHM 3/4-16 x 3.000
H323	2-00-00244	Screw, HHC .25-20 x 1.000
H324	2-00-05329	Screw, HHC M10 x 1.50 x 40MM SS
H325	2-00-00092	Screw, Ph. RHM #8-32 x 1.75 Zn.
H326	2-00-00235	Screw HHC .375-16 x 1.75
H327	2-00-05444	#10-24 BHCS 1.00 Black Oxide
H328	2-00-03994	Carriage Bolt, .31-18 x 1.50
H329	2-00-00036	Screw, RHM #10-24 x .25** NLS
H330	2-00-00397	Flatwasher .875 x .516 x .031 ss
H331	2-00-02779	Fhms #10-32 x .312
H332	2-00-05433	M16 x 1.50 Hex Nut (Metric) Gr 10.9
H333	2-00-00451	Flatwasher .750 x .312 x .065 ss-zn
H334	2-00-05450	Shoulder Screw, 5/16-18 x 3/8
H335	2-00-03404	Clamp - Witteck - C24P
H336	2-00-04620	O-Ring

CHECK ENGINE LIGHT CODES

CATEGORY	DESCRIPTION	CODE NUMBER
MAP	MAP high pressure	231
	MAP low voltage	232
TIP	TIP high voltage	1111
	TIP low voltage	1111
FP	FP high voltage	1111
	FP low voltage	1111
ECT/CHT	ECT/CHT high voltage	221
	ECT/CHT low voltage	222
	ECT higher than expected 1	223
	ECT higher than expected 2	224
	CHT higher than expected 1	223
	CHT higher than expected 2	224
IAT	IAT high voltage	211
	IAT low voltage	212
	IAT higher than expected 1	213
	IAT higher than expected 2	214
BP	BP high pressure	234
	BP low pressure	235
Knock	Knock sensor open	253
	Excessive knock signal	254
Battery Voltage	Voltage high	162
	Voltage low	161
5V External	5VE high voltage	632
	5VE low voltage	631
TPS	TPS1 high voltage	531
	TPS1 low voltage	532
	TPS2 high voltage	533
	TPS2 low voltage	534
	TPS1 higher than TPS2	535
	TPS1 lower than TPS2	536
	Unable to reach higher TPS	537
	Unable to reach lower TPS	538
FPP	FPP1 high voltage	511
	FPP1 low voltage	512
	FPP2 high voltage	521
	FPP2 low voltage	522
	FPP1 higher than IVS limit	513
	FPP1 lower than IVS limit	514
	FPP2 higher than IVS limit	523
	FPP2 lower than IVS limit	524
	FPP1 higher than FPP2	515
	FPP1 lower than FPP2	516
Governor Interlock	IVS/Brake interlock failure	545

CHECK ENGINE LIGHT CODES

CATEGORY	DESCRIPTION	DESCRIPTION	CODE NUMBER
Auxiliary Analog Inputs	AUX analog PD1 high		163
	AUX analog PD1 low		164
	AUX analog PU1 high		541
	AUX analog PU1 low		542
	AUX analog PU2 high		543
	AUX analog PU2 low		544
Engine Speed	Max govern speed override		551
	Fuel rev limit		552
	Spark rev limit		553
Oil Pressure	Oil pressure low		215
Adaptive Learn	AL high gasoline bank 1		141
	AL high gasoline bank 2		151
	AL low gasoline bank 1		142
	AL low gasoline bank 2		152
	AL high LPG		143
	AL low LPG		144
	AL high NG		145
	AL low NG		146
Closed Loop	CL high gasoline bank 1		121
	CL high gasoline bank 2		131
	CL low gasoline bank 1		122
	CL low gasoline bank 2		132
	CL high LPG		111
	CL low LPG		124
	CL high NG		125
	CL low NG		126
Catalyst Monitor	Gasoline cat monitor		133
	LPG cat monitor		134
	NG cat monitor		135
EGO Sensors	EGO open/lazy bank 1		112
	EGO open/lazy bank 2/post-cat		113
	EGO open/lazy post-cat		114
Injectors	Injector Loop Open or Low-Side Short to Ground	Injector 1	311
		Injector 2	313
		Injector 3	315
		Injector 4	321
	Injector Coil Shorted	Injector 1	312
		Injector 2	314
		Injector 3	316
		Injector 4	322

CHECK ENGINE LIGHT CODES

CATEGORY	DESCRIPTION	DESCRIPTION	CODE NUMBER
Spark Coil Primary	Primary Loop Open or Low-Side Short to Ground	Coil 1	411
		Coil 2	413
		Coil 3	415
		Coil 4	421
	Primary Coil Shorted	Coil 1	412
		Coil 2	414
		Coil 3	416
		Coil 4	422
Fuel Pump Feedback	F Pump Loop Open or High-Side Short to Ground		351
	F Pump High-Side Shorted to Power		352
MegaJector Diagnostics	MegaJector delivery pressure higher than expected		353
	MegaJector delivery pressure lower than expected		354
	MegaJector comm lost		355
	MegaJector voltage supply high		361
	MegaJector voltage supply low		362
	MegaJector internal actuator fault detection		363
	MegaJector internal circuitry fault detection		364
	MegaJector internal comm fault detection		365
Crank/Cam Sensors	Cam loss		244
	Cam sync noise		245
	Crank sync noise		242
	Never crank synced at start		243
Internal Processor Diagnostics	COP failure		611
	RTI 1 loss		614
	RTI 2 loss		655
	RTI 3 loss		656
	A/D loss		613
	Invalid interrupt		612
	Flash checksum invalid		615
	RAM failure		616
RS-485 Network	Rx Inactive		641
	Rx Noise		642
	Invalid Packet Format		643
	Shutdown Request		644

Parts may be ordered from American-Lincoln authorized distributors. Record the information from the American-Lincoln serial plate to avoid delays in filling your order:

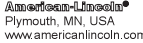
Model: MPV-60	Serial No.:
Part No.:	Code: B06
Fuel:	
Weight: 1293kg	
<small>56100775</small>	
 	

1. Use the model number, catalog number, and serial number when ordering.
2. Give the part number, description, and quantity of parts needed.
3. Give shipping instructions for either freight, UPS, or parcel post.

Parts and supplies listed in this manual can be ordered from the following address:

Nilfisk-Advance, Inc. American-Lincoln Div.	American-Lincoln authorized distributor
14600 - 21 st Ave. No. Plymouth, MN 55447 1-800-214-7700	

MACHINE CATALOG NUMBERS

- | | |
|---------|-----------------------|
| 578-618 | Gas Variable Dump |
| 578-619 | LP Variable Dump |
| 578-620 | Diesel Variable Dump |
| 578-621 | Gas VD Total Steel |
| 578-622 | LP VD Total Steel |
| 578-623 | Diesel VD Total Steel |

American-Lincoln®

14600 21st Avenue North
Plymouth, MN 55447-3408
www.americanlincoln.com
Phone: 800-331-7692
Fax: 877-877-2586
©2006 American-Lincoln