



Electronic Service Manuals

This electronic document is provided as a service to our customers. We do not create the contents of the information contained in this document. Should you have detailed questions pertaining to the information contained in this document, you may contact Michco, or the manufacturer which provided the original information in this electronic deliverable. Michco's only part in this electronic deliverable was the electronic assembly process. By providing this manual on line we are not guaranteeing parts availability.

You may contact Michco through the following methods:

Phone (517) 484-9312 or (800) 331-3339

2011 N. High St. -- Lansing, Michigan -- 48906

Fax: (517) 484-9836

Email: CustServe@Michco.com

Web site: www.Michco.Com

Parts Web site: www.FloorMachineParts.Com

Order Parts on Line at:

www.FloorMachineParts.Com

Directly to Parts & Service:

By Email: **Shop@Michco.com**

By Fax: (517) 702-2041

By Voice: Use numbers above.

Serving the Cleaning Industry Since 1922

Notice: All copyrighted material remains property of original owners, all trademarks are property of respective owners. Manuals are subject to Manufacturer's reproduction limitations. Originals or reproductions were provided by manufacturers through a request. We make no warranty as to the correctness of information provided in this document and you assume all risk. By placing these manuals on line we are not declaring our corporation to be an manufacturer authorized dealer or provider, please check our web site for authorized manufacturers we represent.



AMERICAN-LINCOLN TECHNOLOGY



SMART 2000 Sweeper/scrubber ELECTRICAL TROUBLESHOOTING GUIDE

Beginning with Serial No. 690001



TABLE OF CONTENTS

CAUTION STATEMENT	2
5 HP. DRIVE MOTOR	3
MAIN AND SIDE BROOM CIRCUIT	4
SCRUB DECK AND DRIVE CONTROL	5
CHIME & HOPPER ACT. CIRCUIT	7
VACUUM OPERATION AND CONTROL	8
SQUEEGEE CONTROL	9
DUST FAN & SHAKER CIRCUIT	11
HORN, HOUR AND CONDITION METER CIRCUITS	12
LOW BATTERY SHUT DOWN CIRCUIT	13

ELECTRICAL SERVICE GUIDE

SMART 2000

CAUTION STATEMENT

As with all electrical equipment, caution is essential when doing electrical service. Remove all watches, rings and jewelry before proceeding. Take care when doing power checks. Take time needed to place meter leads correctly so as not to short to nearby terminals and/or electrical connections. Do not forget to disconnect power at the battery when doing continuity checks or damage to your test meter may result. All Electrical service should be done by a qualified technician experienced in DC voltage and DC testing equipment.

GENERAL STATEMENT

The following guide will present each electrical circuit separately, not including options, unless they are in electrical series with the standard machine.

1. "Power Off" means key switch is turned off.
2. "Power Disconnect" means battery unplugged from the machine.
3. All voltages are taken with the battery plugged in and the key switch on unless noted otherwise.
4. All voltage readings are taken with the meter (-) lead connected to the battery (-) or the (-) side of the condition meter unless otherwise specified.
5. All continuity readings are taken with the key switch off or the battery disconnected.

5 HP. DRIVE MOTOR

Conditions necessary for circuit to work

- 1. Battery voltage 36VDC
- 2. Key switch on
- 3. CB-10 & FU1 closed
- 4. Solenoid 1A closed
- 5. Seat switch closed

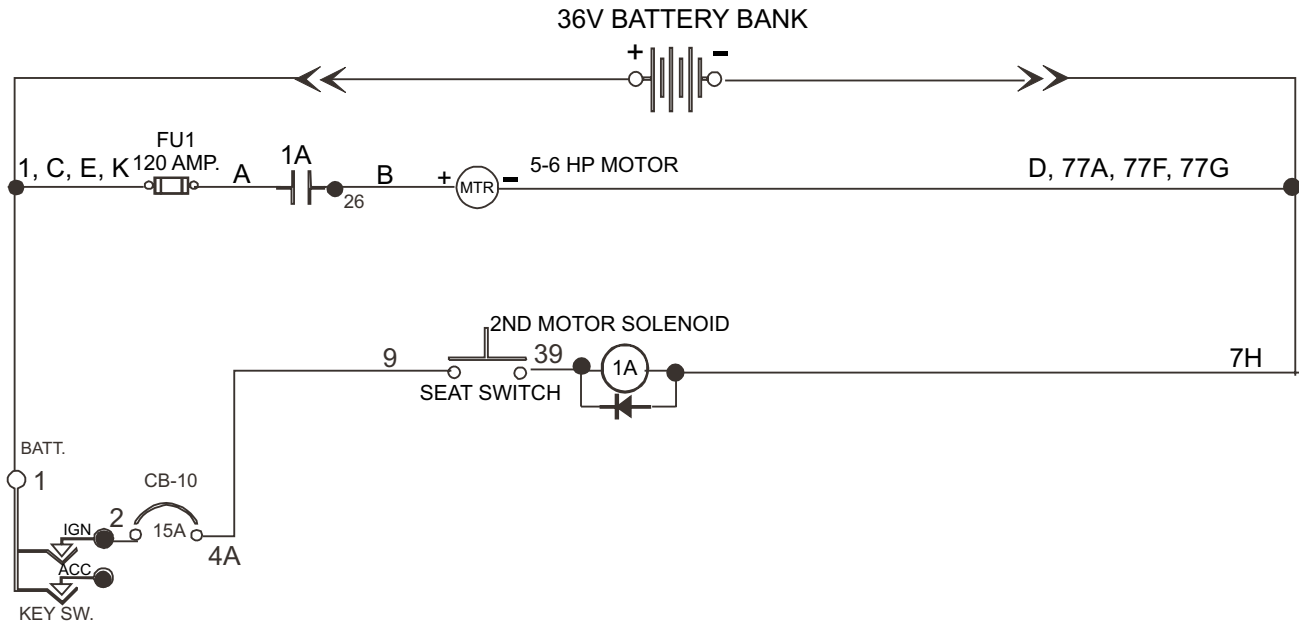

T135

MAIN AND SIDE BROOM CIRCUIT

MAIN AND SIDE BROOM CIRCUIT

Conditions necessary for circuit to work

1. Battery voltage 36VDC
2. Key switch on
3. CB-10 closed
4. Solenoid 4A closed
5. Seat switch closed
6. Broom limit switch closed
7. Solenoid (1A) closed
8. Hopper switch closed

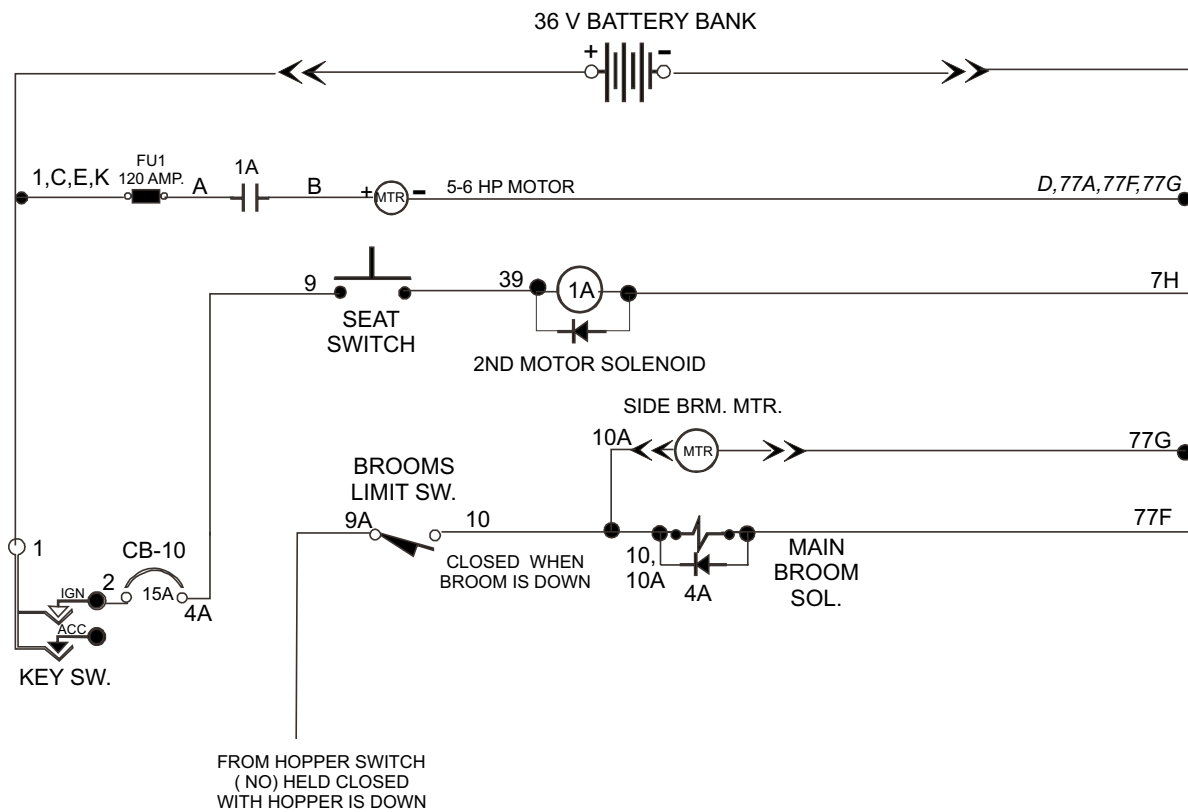

T136

BRUSHES AND SOLUTION OFF IN NEUTRAL CIRCUIT

Conditions necessary for circuit to work

- 1 - Battery voltage >32.5Vdc
- 2 - Key switch on in IGN or ACC mode
- 3 - CB-6, CB-7, & CB-11 closed

Scrub deck lowers when contactor 15A is energized by:

- 1- Scrub deck Switch placed from the Up(raise) position to the middle(Normal Down) position.

OR

- 2- Scrub deck Switch placed from the Up(raise) position or the middle(Normal Down) position to the lower(Heavy Down) position

AND

While 15A is Energized the deck will lower until the corresponding Normal Down or Heavy Down Prox switch is made opening the circuit & de-energizing 15A

Scrub deck raises when contactor 14A is energized by:

- 1- Scrub deck Switch placed from the middle (Normal Down) or the lower (Heavy Down) position to the Up (Raise) position

OR

- 2- When scrub deck switch in lower (Heavy Down) and the Overload Prox switch is activated by over travel of the deck.

SCRUB DRIVE CONTROL

- 1 - Battery Voltage >32.5V
- 2 - Key Switch On in Ign or ACC position
- 3 - Scrub deck in Normal or Heavy Down position
- 4 - Contactor 8A energized

Scrub Deck Control Contactor 8A is energized with the above conditions met when:

-M12 is energized by either the forward or reverse foot pedal proximity switch being activated.
(this prevents operation in neutral)

AND

-TD2 is energized (Requires battery Voltage >32.5Vdc)

AND

-Relay SPD2 is de-energized (Squeegge Interlocks prevents both Squeegge motor & Brush motors from starting together to prevent low voltage fault of squeegge due to excessive in rush)

AND

-M10 is De-energized (Scrub deck Interlock to verify Scrub deck Switch is NOT in the top (UP request) position.

CHIME & HOPPER ACTUATOR CIRCUIT

Conditions necessary for circuit to work

1. Battery voltage
2. Key switch on
3. CB-10, CB-12 & CB-13 closed
4. Hopper switch closed when hopper is open.
5. FU1 Closed
6. Seat switch closed.
7. Solenoid (1A) closed
8. Hopper switch in up or down position.

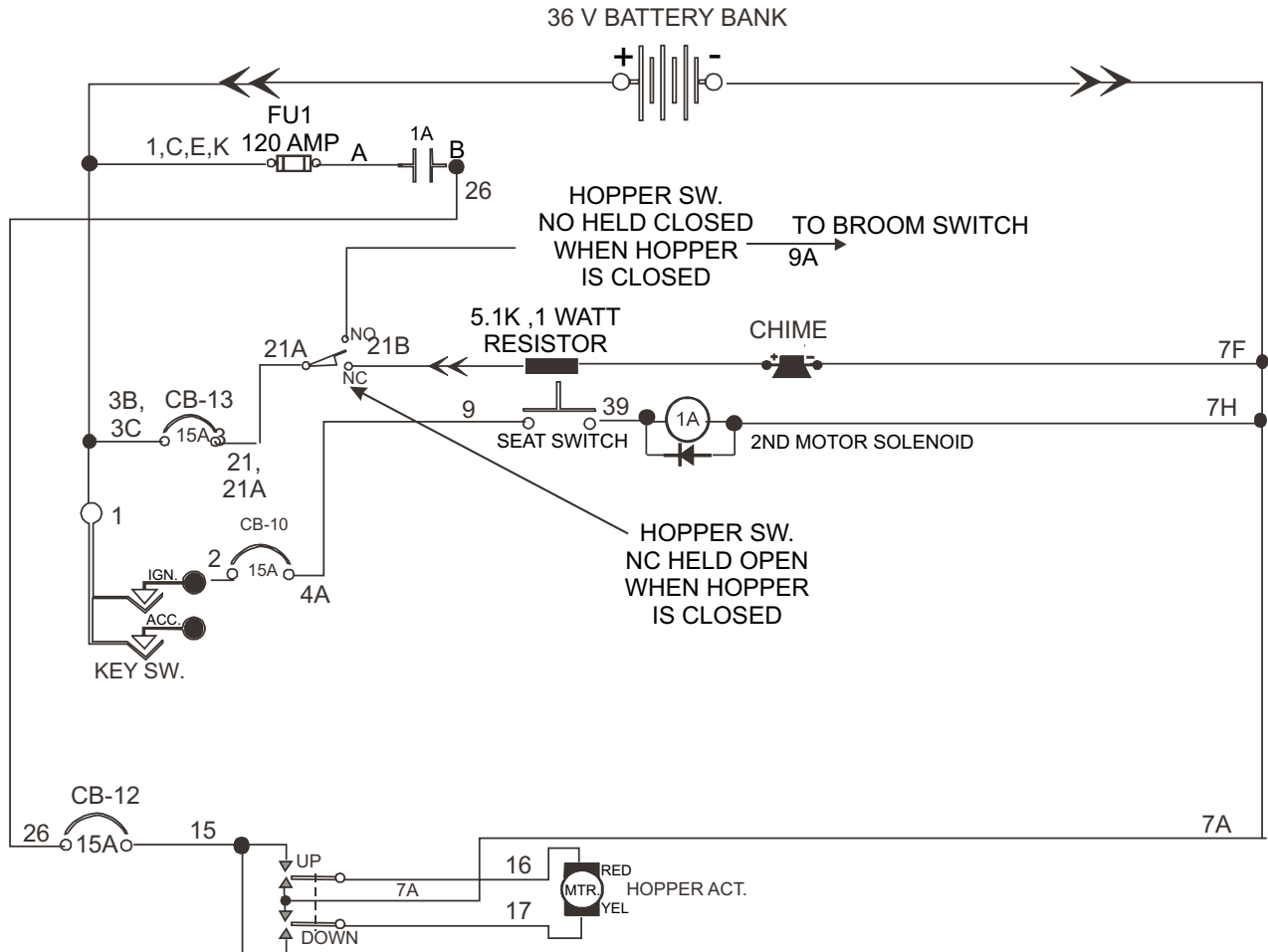

VACUUM AND SQUEEGEE CIRCUIT

VACUUM AND SQUEEGEE CIRCUIT

Conditions necessary for vacuum & circuit to operate

- 1 - Battery voltage
- 2 - Key switch on
- 3 - CB-3, CB-4, CB-9, CB-11 & FU2 closed
- 4 - Contactor 3A controls power to the Vacuum motors & is energized when the Squeeggee switch is placed in the middle & lower positions

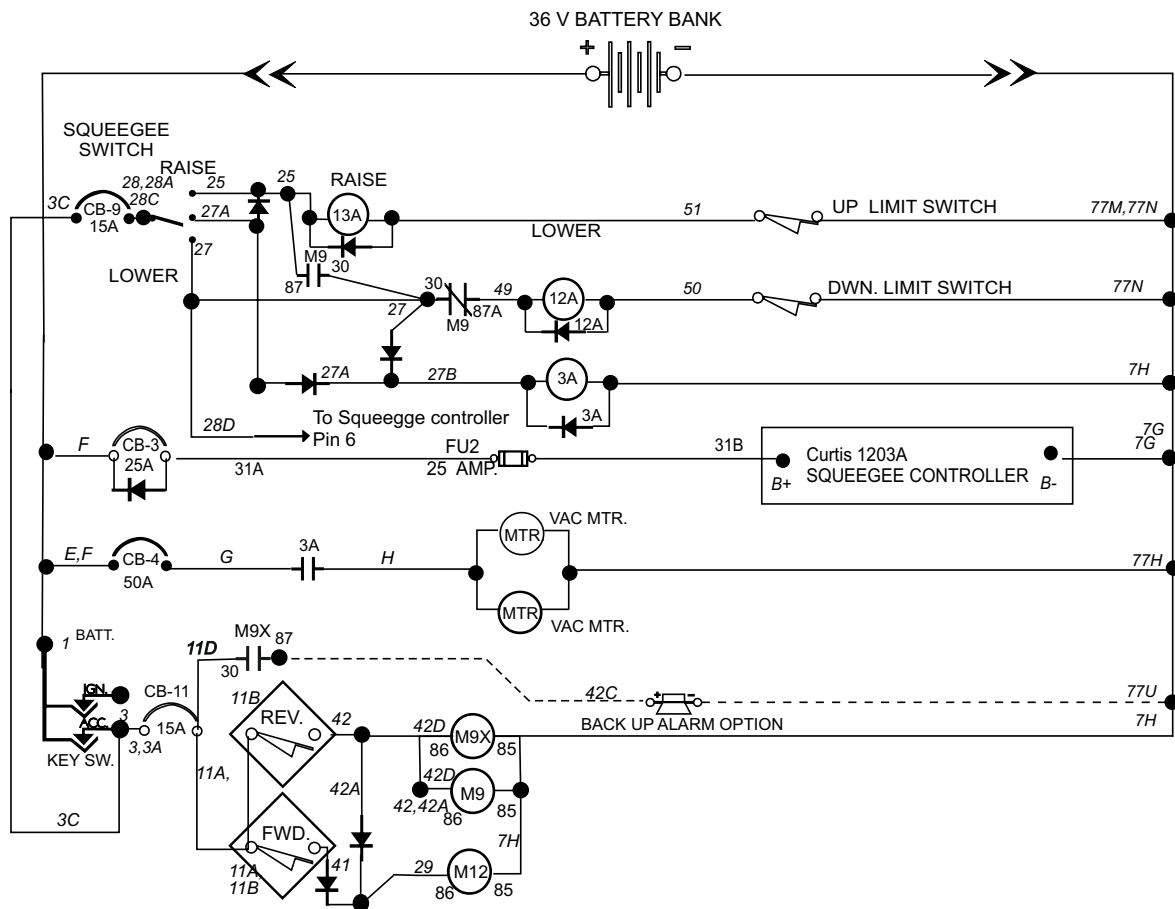

Conditions necessary for Squeegee circuit to operate

- 1 - Battery voltage
- 2 - Key switch on
- 3 - CB-3, CB-9 , CB-11 & FU2 closed
- 4 - Power to the Curtis 1203A Pin 6 Keyswitch input

To Lower the Squeegee

- 1 - Place the Squeegee selector Switch in the lower position.

The Squeegee will raise when

- 1- The Squeegeed selector Switch is placed in the middle or top position

Or

- 2- With the Squeegee selector Switch in the lower position & the Squeegee down then pressing the foot pedal in reverse will raise the squeegee.

The Curtis 1203A motor controller drives the Squeegee motor up & down.

- Pins 1-3 on the Curtis, Resistor Assembly C-1 & Relay SPD provide the STOP/RUN commands to the controller
- With relay SPD de-energized it's contacts connect the 170 Ohm Resistor located between resistor Assy C-1 Terminals T1 &T2 to Pin 1 & Pin 2 respectively. Any Resistance of 200 Ohms or less between Pin 1 & Pin 2 Provides a STOP signal
- With Relay SPD Energized it's contacts connect the 4.7k Ohm & the 170 Ohm resistor located in series between Resistor Assy C-1 Terminals T1 &T3 to Pin1 & Pin 2 respectively. A resistance of 4.8k Ohms or more between Pin 1 & Pin 2 Provides a full speed signal
- The three Resistors located in series between resistor Assy C-1 Terminals T1 &T4 places 5.1KOhms between Pin 1 & Pin 3. This is required at all Times . Less than 5KOhms from Pin1 to Pin3 at ANY time is a Open circuit input & will cause the 1203A to fault & disable Squeegees operation
- Relay SPD is energized whenever relay 12A or relay 13A (but not both) are energized & time delay relay TD3 has had it's 3 second time out.
- Relay 12A & 12B are energized when the Squeegee Selector switch is in the lower position.
- Relay 13A is energized when the Squeegee Selector switch is in the up or middle positions & anytime relay M9 is Energized
- Relay is Energized when the foot pedal is placed in reverse activating the reverse proximity switch.
- TD3 provides a 3 second delay in energizing SPD on startup. This delay is required because the Curtis controller has a high pedal startup disable feature & will NOT initialize if a Run signal is present at startup.
- Normally closed contacts on Relay 12B complete the circuit between pins 4&5 on the Curtis controller and provide the UP/DOWN directional signal to the controller.
- With 12 B de-energized it's N.O. contact creates a open circuit between pins 4 & pin 5 that provides a UP directional signal
- With 12 B energized the N.O. contact closes creating a closed circuit between pins 4 & pins 5 and provides a Down directional signal

SQUEEGEE CONTROL

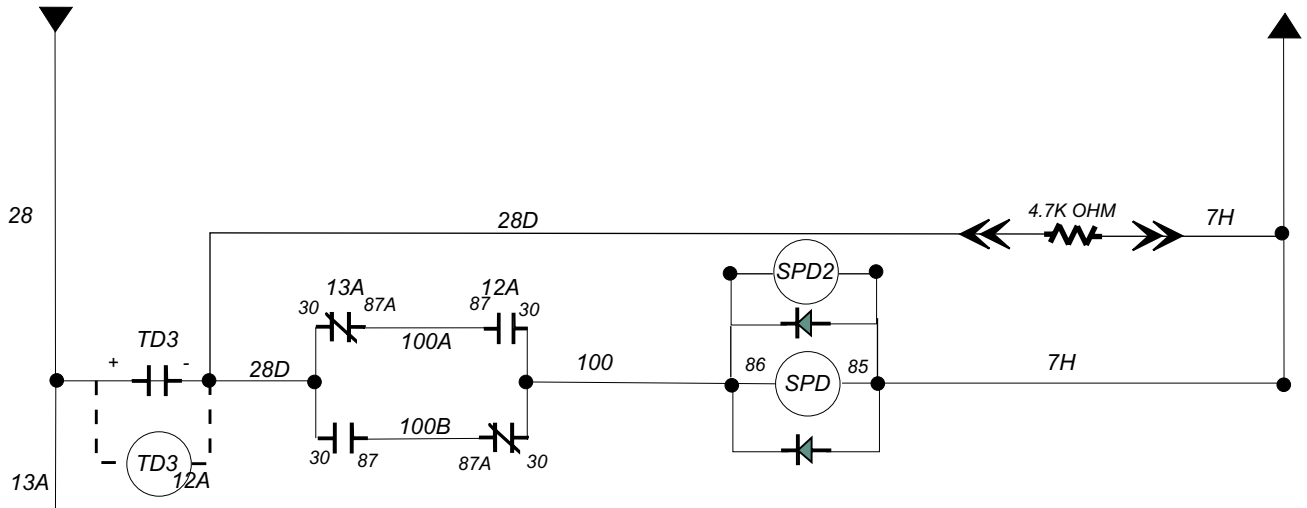

CURTIS 1303-303 CONTROLLER

RESISTOR ASSY. C-1

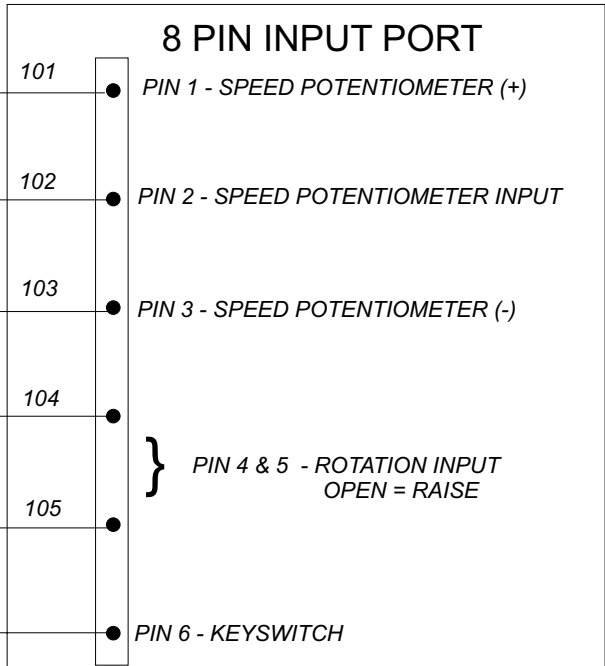
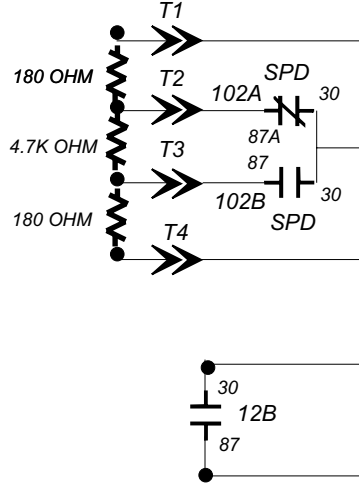

Continued on 71365 SHT 1

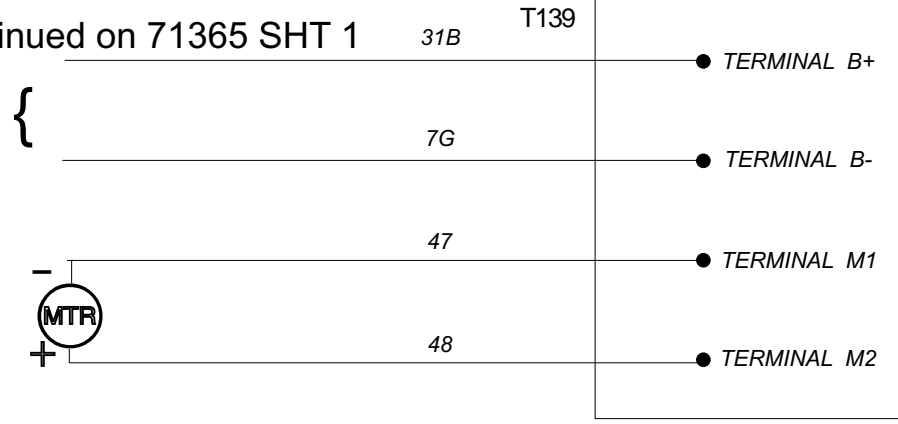

DUST FAN & SHAKER CIRCUIT

Conditions necessary for circuit to work

1. Battery voltage
2. Key switch on
3. CB-14 & CB-15 closed
4. Solenoid 7A closed
5. Seat switch closed
6. Dust fan or shaker switch in on position.
7. Relay M1 & M11 closed
8. TD-1 closed for shaker motor circuit

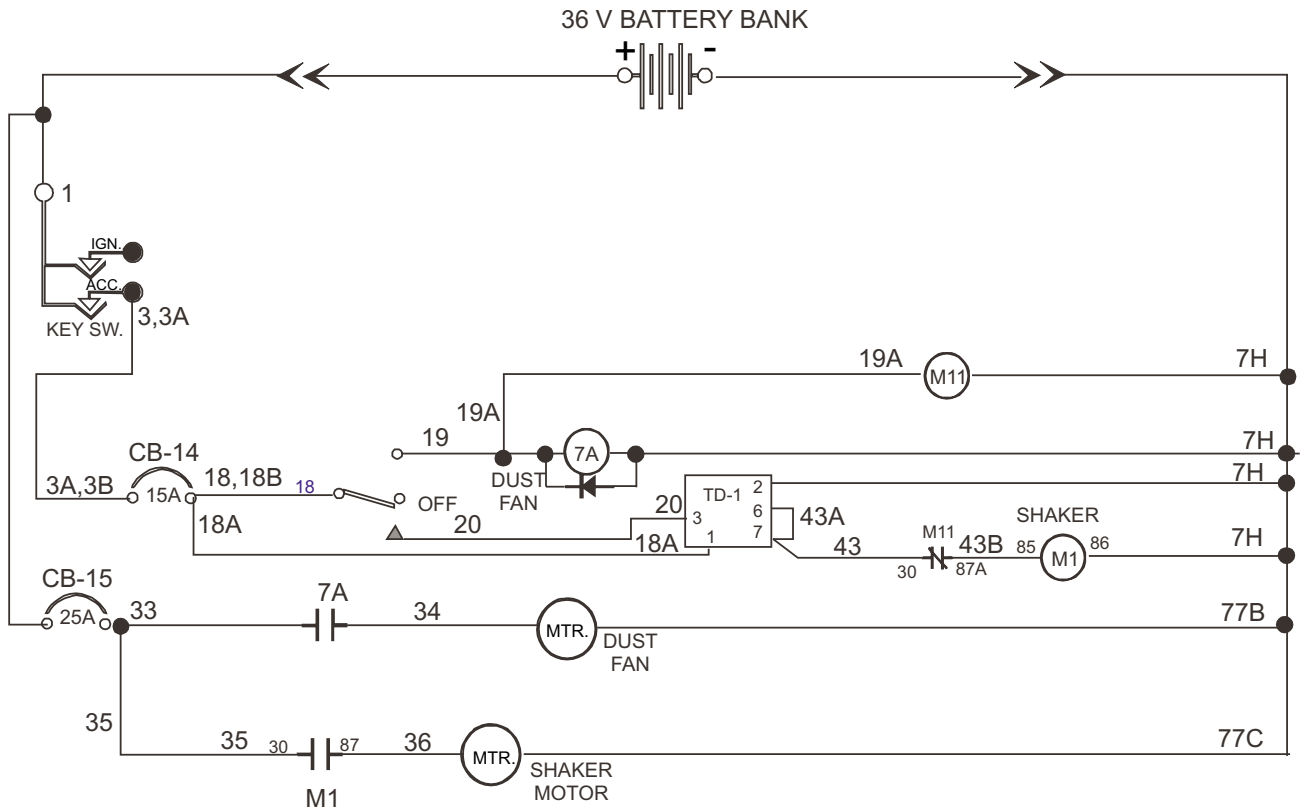

T140

HORN, HOUR AND CONDITION METER CIRCUITS

HORN, HOUR AND CONDITION METER CIRCUITS

Conditions necessary for circuits to work:

1. Battery voltage.
2. Key switch on.
3. FU1, CB-5, 10 & 11 closed.
4. Horn button depressed. (for horn only)
5. Seat switch closed, machine in Fwd. Or Rev. for hour meter to work.
6. Solenoid (1A) closed.

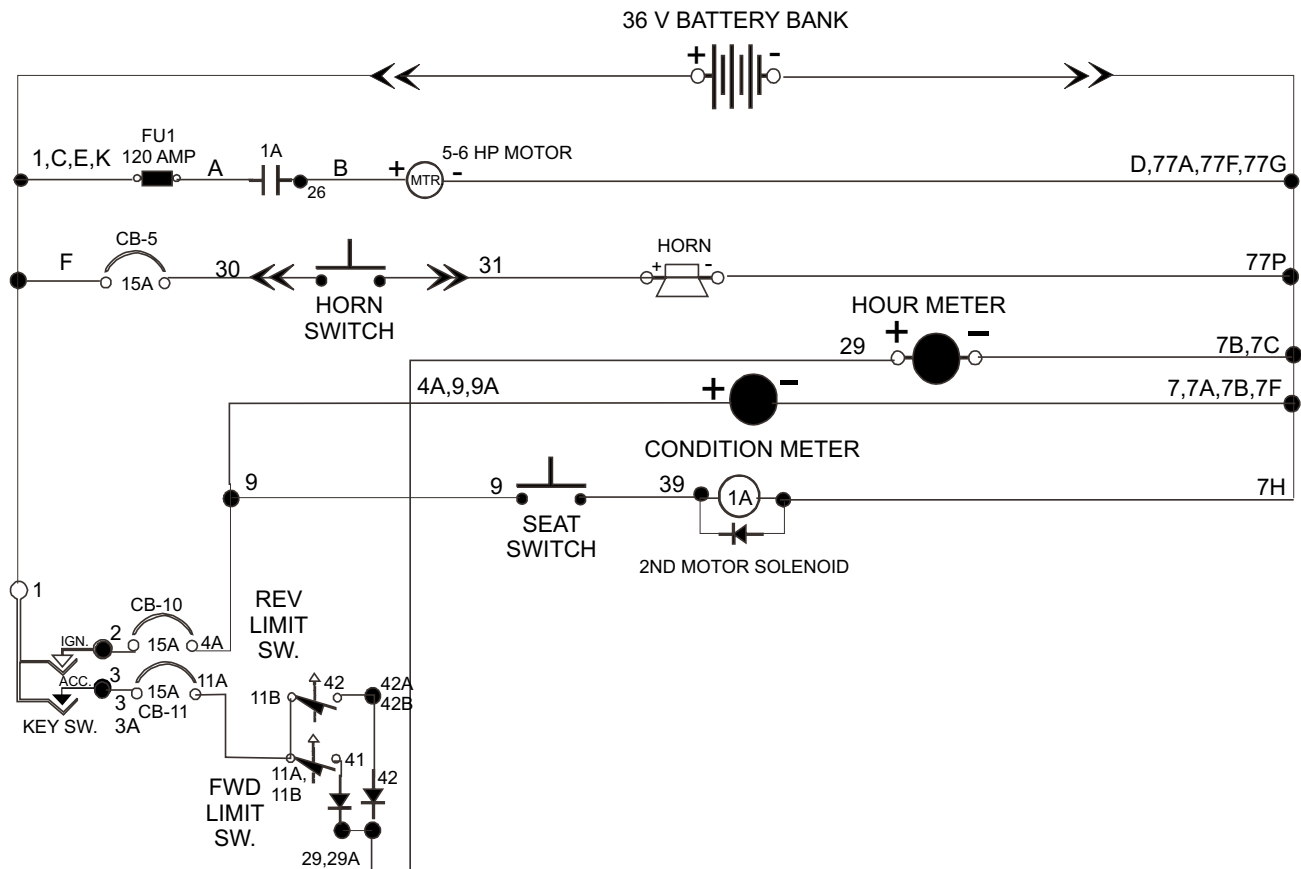

T141

LOW BATTERY SHUT DOWN CIRCUIT

Conditions necessary for circuit to work

1. Battery voltage at 31.5VDC for 2-3 seconds.
2. Key switch on
3. CB-11 closed
4. Solenoid 8A opens with battery voltage at 31.5(CCV) for 2 to 3 seconds.
5. Water shut off solenoids open
6. Items 4 and 5 can be re -set by turning key off and then back on.
7. TD-2 is closed in forward or reverse.
8. M12 is closed in forward or reverse.

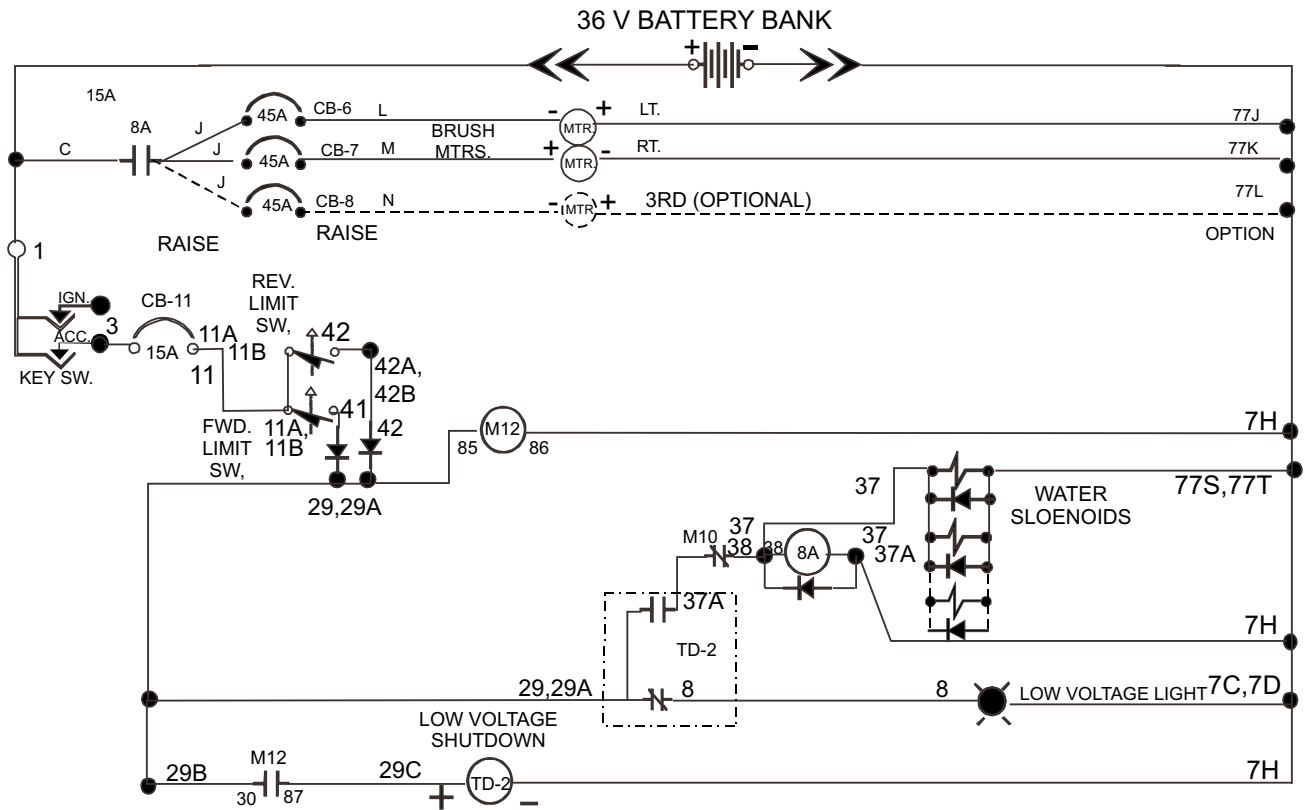

T142