



## Electronic Service Manuals

This electronic document is provided as a service to our customers. We do not create the contents of the information contained in this document. Should you have detailed questions pertaining to the information contained in this document, you may contact Michco, or the manufacturer which provided the original information in this electronic deliverable. Michco's only part in this electronic deliverable was the electronic assembly process. By providing this manual on line we are not guaranteeing parts availability.

You may contact Michco through the following methods:

Phone (517) 484-9312 or (800) 331-3339

2011 N. High St. -- Lansing, Michigan -- 48906

Fax: (517) 484-9836

Email: [CustServe@Michco.com](mailto:CustServe@Michco.com)

Web site: [www.Michco.Com](http://www.Michco.Com)

Parts Web site: [www.FloorMachineParts.Com](http://www.FloorMachineParts.Com)

Order Parts on Line at:

**[www.FloorMachineParts.Com](http://www.FloorMachineParts.Com)**

Directly to Parts & Service:

By Email: **[Shop@Michco.com](mailto:Shop@Michco.com)**

By Fax: (517) 702-2041

By Voice: Use numbers above.

**Serving the Cleaning Industry Since 1922**

Notice: All copyrighted material remains property of original owners, all trademarks are property of respective owners. Manuals are subject to Manufacturer's reproduction limitations. Originals or reproductions were provided by manufacturers through a request. We make no warranty as to the correctness of information provided in this document and you assume all risk. By placing these manuals on line we are not declaring our corporation to be an manufacturer authorized dealer or provider, please check our web site for authorized manufacturers we represent.



## TABLE OF CONTENTS

<b>SPECIFICATIONS</b> .....	<b>1-4</b>
<b>MACHINE DIMENSIONS</b> .....	<b>1-6</b>
<b>STANDARD HARDWARE &amp; TORQUE VALUES</b> .....	<b>1-7</b>
<b>HYDRAULIC TORQUE REQUIREMENTS</b> .....	<b>1-8</b>
<b>DECIMAL - METRIC CONVERSION TABLE</b> .....	<b>1-9</b>
MACHINE PREPARATION .....	1-10
PREPARING THE MACHINE FOR OPERATION .....	1-10
BATTERY POWERED MACHINE PREPARATION .....	1-11
SAFETY INSTRUCTIONS .....	1-12
OPERATION OF CONTROLS AND GAUGES .....	1-15
LIGHT SWITCH .....	1-15
HORN BUTTON .....	1-15
KEY SWITCH .....	1-15
HOUR METER .....	1-15
BATTERY CONDITION METER .....	1-16
BATTERY CONDITION LIGHT .....	1-16
SEAT POSITION ADJUSTMENT .....	1-16
FILTER SHAKER SWITCH .....	1-17
DUST CONTROL SWITCH .....	1-17
MAIN BROOM AND SIDE BROOM SWITCH .....	1-17
SIDE BROOM ADJUSTMENT .....	1-17
MAIN BROOM ADJUSTMENT .....	1-17
SCRUB DECK SWITCH .....	1-18
SQUEEGEE SWITCH .....	1-18
SOLUTION CONTROL KNOB .....	1-18
LOW SOLUTION LIGHT (WARNING LIGHT) .....	1-19
RECOVERY HIGH LIGHT (WARNING LIGHT) .....	1-19
PARKING BRAKE .....	1-19
TURN SIGNAL (4-WAY) OPTION .....	1-19
HYDRAULIC RESERVOIR LEVEL SIGHT GAUGE .....	1-19
ACCELERATOR and DIRECTIONAL CONTROL PEDAL .....	1-20
BACK-UP ALARM SWITCH .....	1-20
FILTER PANEL KNOB .....	1-20
MAIN BROOM COMPARTMENT DOOR .....	1-21
HOPPER LIFT SWITCH .....	1-21
ESP SYSTEM OPERATING INSTRUCTIONS .....	1-22
THE SCRUBBING SYSTEM - HOW IT WORKS .....	1-22
THE NON-RECYCLING OR STANDARD SCRUBBING SYSTEM - HOW IT WORKS .....	1-22
RECOVERY OR ESP SYSTEM - HOW IT WORKS .....	1-22
OPERATING INSTRUCTIONS .....	1-23
BEFORE STARTING THE ENGINE .....	1-23
PRE-START CHECKLIST .....	1-23
STARTING BATTERY MACHINES .....	1-23
POST-OPERATION CHECKLIST .....	1-23
SERVICE CHART .....	1-24
HELPFUL HINTS FOR CLEANING OPERATION .....	1-26
<b>SERVICE PRECAUTIONS</b> .....	<b>1-27</b>
SERVICE INSTRUCTIONS .....	1-28
MAIN BROOM .....	1-28
CHECKING THE MAIN BROOM SWEEP PATTERN .....	1-28
ADJUSTING THE MAIN BROOM HEIGHT .....	1-28
REPLACING THE MAIN BROOM .....	1-28
MAIN BROOM LEVEL ADJUSTMENT .....	1-28
SIDE BROOM .....	1-29
CHECKING THE SIDE BROOM SWEEP PATTERN .....	1-29

## TABLE OF CONTENTS

REPLACING THE SIDE BROOM .....	1-29
HOPPER .....	1-30
CLEANING THE HOPPER .....	1-30
ADJUSTING THE HOPPER SWITCH .....	1-30
DUST CONTROL FILTER .....	1-30
CHECKING THE DUST CONTROL FILTER .....	1-30
CLEANING THE DUST CONTROL FILTER .....	1-30
REPLACING THE DUST CONTROL FILTER .....	1-31
DUST FLAPS .....	1-31
CHECKING THE DUST FLAPS .....	1-31
ADJUSTING THE DUST FLAPS .....	1-31
BRAKES .....	1-32
ADJUSTING THE BRAKE PEDAL .....	1-32
ADJUSTING THE BRAKES .....	1-32
ADJUSTING THE FOOT THROTTLE SWITCH .....	1-32
GENERAL MACHINE MAINTENANCE .....	1-33
FILLING THE HYDRAULIC RESERVOIR .....	1-33
CLEANING THE HYDRAULIC SYSTEM .....	1-33
REPLACING THE RETURN FILTER ELEMENT .....	1-33
REPLACING THE SCRUB BRUSH .....	1-34
ADJUSTING THE SCRUB DECK .....	1-34
COVERS AND LATCHES .....	1-34
SOLUTION LOW WARNING LIGHT .....	1-34
RECOVERY HIGH WARNING LIGHT .....	1-34
SOLUTION CONTROL .....	1-34
RECYCLING PUMP ESP SYSTEM .....	1-35
RECYCLING PUMP STORAGE .....	1-35
REAR SQUEEGEE .....	1-35
ADJUSTING THE REAR SQUEEGEE LIFT .....	1-35
SQUEEGEE CASTER WHEELS .....	1-35
ADJUSTING CASTERS .....	1-35
EMPTYING THE RECOVERY TANK .....	1-36
<b>PARTS LIST LEGEND .....</b>	<b>1-37</b>
<b>HARDWARE LEGEND .....</b>	<b>1-38</b>
<b>ORDERING PARTS .....</b>	<b>1-44</b>
<b>ELECTRICAL SCHEMATIC (BATTERY) .....</b>	<b>1-45</b>
<b>CONNECTION - HARNESS ROUTING (BATTERY) .....</b>	<b>1-46</b>
<b>HYDRAULIC SCHEMATIC (BATTERY) .....</b>	<b>1-47</b>
CHAPTER 2 (PARTS LIST) .....	2-1
MAIN BROOM .....	2-2
MAIN BROOM BAFFLE AND FLAPS .....	2-6
SIDE BROOM (12V & 36V) .....	2-8
HOPPER ASSEMBLY (12V & 36V BATTERY) .....	2-10
SCRUB DECK ACTUATOR .....	2-12
SCRUB DECK ASSEMBLY (40") .....	2-14
SCRUB DECK ASSEMBLY (46") .....	2-17
SIDE SQUEEGEE (40") .....	2-19
SIDE SQUEEGEE (46") .....	2-20
REAR SQUEEGEE (40") .....	2-22
REAR SQUEEGEE (46") .....	2-24
REAR SQUEEGEE LIFT SYSTEM (12V AND 36V) .....	2-26
SWING SQUEEGEE SUPPORT .....	2-28
SOLUTION TANK .....	2-30
SOLUTION CONTROL .....	2-32
RECOVERY TANK .....	2-34

## TABLE OF CONTENTS

FORWARD AND REVERSE CONTROL (BATTERY) .....	2-36
BRAKE ASSEMBLY .....	2-38
FRONT WHEEL ASSEMBLY .....	2-40
REAR WHEEL ASSEMBLY .....	2-42
FRONT COVER AND LATCH ASSEMBLY .....	2-44
SEAT ASSEMBLY .....	2-46
ACCESS PANELS .....	2-47
ROLL OUT BATTERY .....	2-48
DUST CONTROL (BATTERY) .....	2-50
VACUUM MANIFOLD SYSTEM .....	2-54
HYDRAULIC MOTOR AND PUMP ASSEMBLY .....	2-56
MOTOR AND PUMP MOUNTING ASSEMBLY .....	2-58
HYDRAULIC RESERVOIR ASSEMBLY .....	2-59
HYDRAULIC FILTER AND SOLENOID ASSEMBLY .....	2-60
HYDRAULIC CONNECTION DIAGRAM .....	2-62
POWER PANEL (36V) .....	2-64
POWER STEERING .....	2-66
ELECTRICAL POWER PANEL (36V) .....	2-68
INSTRUMENT PANEL .....	2-70
DECALS .....	2-74
CHAPTER 3 (OPTIONS) .....	3-1
BACK-UP ALARM (12V & 36V) .....	3-2
BATTERY STAND .....	3-3
ESP (12V & 36V) .....	3-4
FIRE EXTINGUISHER .....	3-7
LIGHT PACKAGE .....	3-8
OVER HEAD GUARD (OHG) .....	3-9
STROBE LIGHT WITHOUT OHG (12 & 36 VDC) .....	3-10
STROBE LIGHT WITH OHG (12 & 36 VDC) .....	3-12
SEAT BELT ASSEMBLY .....	3-14
SQUEEGEE WAND .....	3-15
PAD DRIVER (20") .....	3-16
SPRAY & VAC WAND (12V & 36V) .....	3-17
HYDRAULIC KIT .....	3-21
<b>INDEX</b> .....	<b>3-22</b>
<b>WARRANTY</b> .....	<b>3-25</b>

## SPECIFICATIONS

---

<b>CLEANING PATH</b>		
Scrubbing	-	40 in. (101 cm)
	-	46 in. (117 cm)
Sweeping	-	46in. (117 cm)
Edge Cleaning	-	6 in.(15 cm) Right Side 46in. 117 cm) only
<b>TRAVEL SPEED</b>	-	0-4 MPH (0 - 6.4kph)
<b>STEERING</b>	-	Rack & Pinion 90°-90° Hyd. Power Steering
	-	Adjustable Steering Column
<b>TURNING RADIUS</b>		
Left	-	59 in. (150 cm)
Right	-	59 in. (150 cm)
Aisle "U" Turn	-	87 in. (221 cm)
<b>DIMENSIONS</b>		
Length	-	87 in. (221 cm)
Width	-	46 in. (116.8 cm)
Height	-	52 in. (132 cm)
Height w/Overhead Guard	-	79 in. (200.6 cm)
Wheel Base	-	37.6 in. (95.5 cm)
<b>WEIGHT</b>		
Standard Machine (Battery)	-	1700 lbs. (765 kg.) without battery
	-	510 Ah battery 1800 lbs. (810 kg)
	-	720 Ah battery 1990 lbs. (896 kg)
<b>TIRES</b>		
Front (Battery) Solid Urethane	-	Two (2)16 in (41cm) x 3.75 in (8.26 cm)
Rear (Battery) Solid Rubber	-	One (1)16 in (41 cm) x 4.00 in (10.16cm)
<b>RAMP CLIMBING</b>		
Transporting	-	8° (battery)
<b>MAIN BROOM</b>		
One piece plastic core disposable type. Broom position can be set to "restricted down" or "free floating".		
Length	-	36 in (91.4 cm)
Diameter	-	10 inches (25.4 cm)
Optional Bristle Type	-	Nylon (High density)
	-	Proex
	-	Nylon Eight (8) Row
<b>SIDE BROOM</b>		
Side Broom Size	-	16 inches (40.6 cm) Diameter

**INSTRUMENTS AND CONTROLS**

Main/Side Broom Switch (activates immediately when lowered)		Key Switch
Headlight/Taillight Switch (option)		Rectangular Hour Meter
Squeegee Switch		Battery Rollout
3 Position Scrub Deck Switch		Recovery High Light
Horn Button		Dust Control Switch(with certain models)
Solution Control		Solution Low Light
Hopper Up/Down		Coolant Temperature Light
		Filter Shaker Switch

**SCRUBBING SYSTEM**

Brush Size-46" (116.84 cm)	-	Three (3) 16" (40.6cm) Diameter
Brush Size-40" (101.4 cm)	-	Two (2) 20" (51cm) Diameter
Brush Drive Lift	-	Electric Actuator
Scrub Load		
40" scrub path )(116.84 cm)	-	From 90 lbs. to 140 lbs. per brush (Battery)
46" scrub path)(101.4 cm)	-	From 90 lbs. to 140 lbs. per brush (Battery)

**SQUEEGEE**

Rear	-	Accu-Trac™ 46 in(116.8 cm) Swing, break away, w/no tool squeegee replacement
Side	-	26 in (66 cm) Easy Change

**TANKS**

Solution Tank	-	55 Gallons (208 liter)Polyethylene
Recovery Tank	-	55 Gallons (208liter)Polyethylene
Solution Metering	-	Variable to 3.0 GPM (11.4 lpm)
Drain Hose	-	48 in (122 cm) No Plug required
Clean Out Port	-	5.7 in (14.5 cm) heavy debris

**HOPPER**

Capacity	-	2.5 cu.ft.(71liter)
----------	---	---------------------

**DUMP AND LIFT**

Dump Height	-	14 in (35.6 cm.)
-------------	---	------------------

**SYSTEM FLUID CAPACITIES**

Hydraulic System (Battery)	-	4.7 Gallons (17.79 Liters)
----------------------------	---	----------------------------

**OPTIONAL EQUIPMENT**

Back-Up Alarm		Headlight/Taillights
Push Pull Light Switch (Work Light)		Strobe Light (Red or Amber)
ESP System w/o Detergent Provisions		Overhead Guard
Pad Drivers		Arm Rest
Spray and Vac Wand Option		Fire Extinguisher
Linatex Squeegee		Squeegee Wand
720 Amp Hour Battery		510 Amp Hour Battery

# MACHINE DIMENSIONS

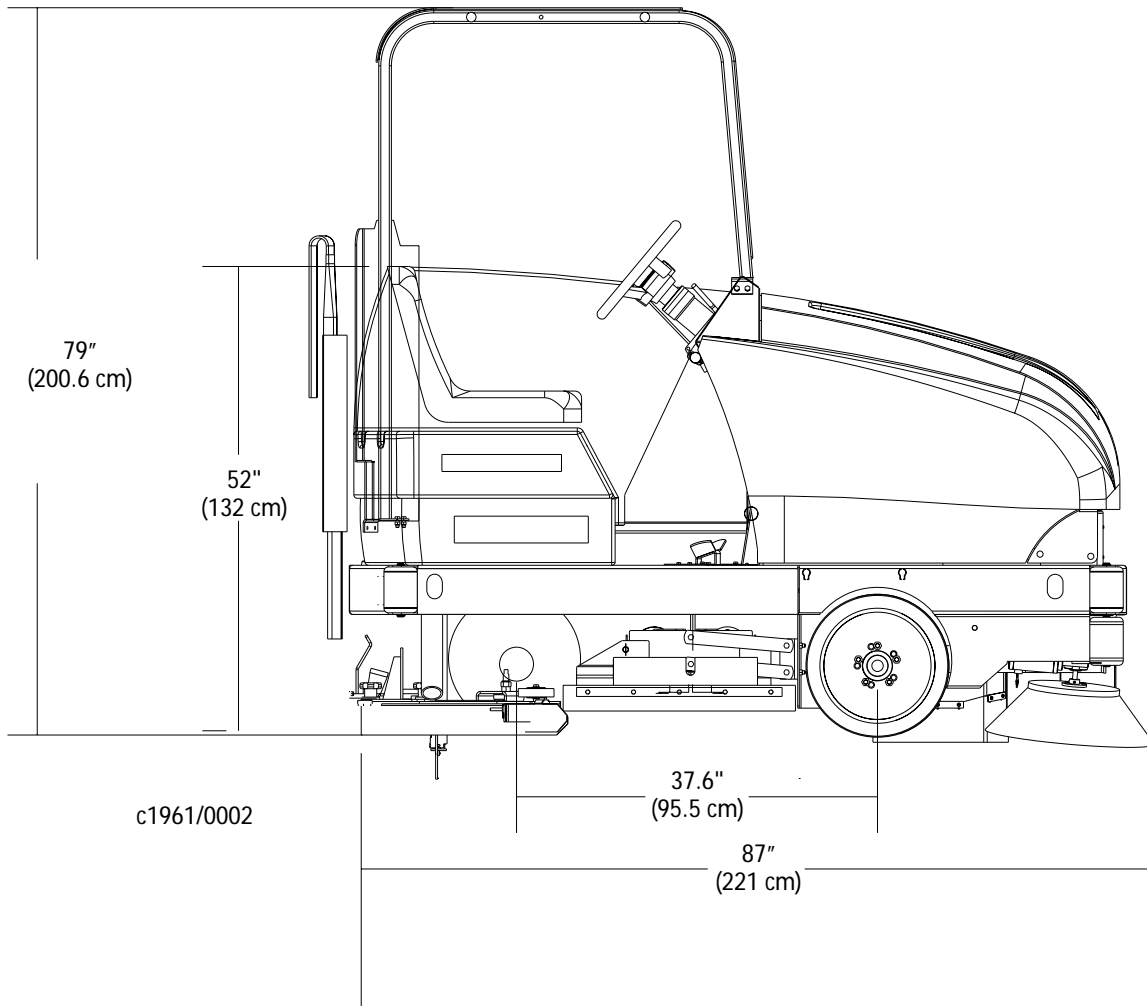
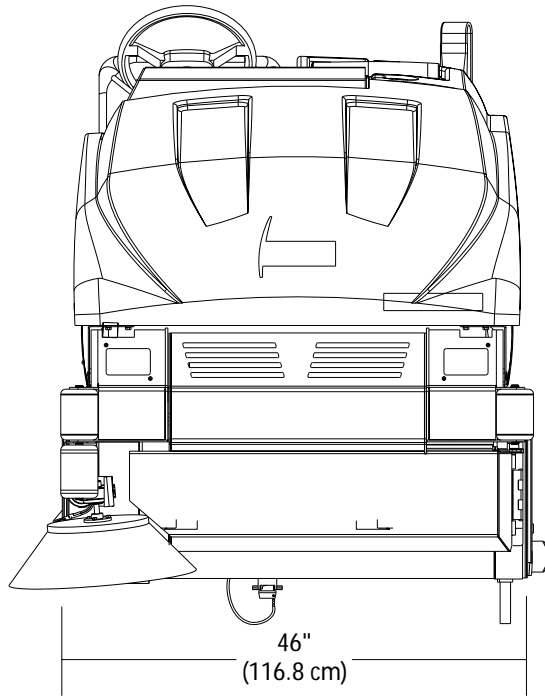

## BOLT IDENTIFICATION

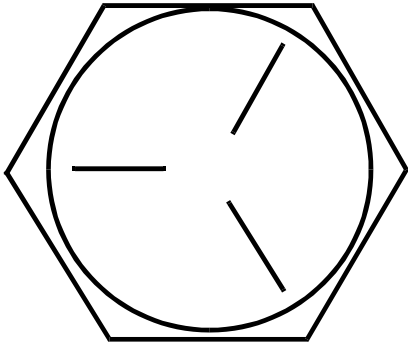

SAE - Grade 5

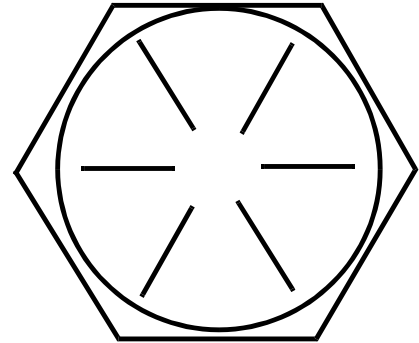

SAE - Grade 8

Screw Size	Grade 5 Plated		Grade 8 Plated		410H Stainless		Brass	Type F & T & BT		Type B, AB
	C	F	C	F	C	F		C	F	
*6	14	15	-	-	18	20	5	20	23	21
*8	27	28	-	-	33	35	9	37	41	34
*10	39	43	-	-	47	54	13	49	64	49
*1/4	86	108	130	151	114	132	32	120	156	120
5/16	15	17	22	24	19	22	6	-	-	-
3/8	28	31	40	44	34	39	10	-	-	-
7/16	44	49	63	70	55	62	16	-	-	-
1/2	68	76	95	108	85	95	-	-	-	-
9/16	98	110	138	155	-	-	-	-	-	-
5/8	135	153	191	216	-	-	-	-	-	-
3/4	239	267	338	378	-	-	-	-	-	-
7/8	387	-	545	-	-	-	-	-	-	-
1	579	-	818	-	-	-	-	-	-	-

C = Coarse Thread

F = Fine Thread

\* = Torque values for #6 through 1/4 are lb./in. All others are lb./ft.

NOTE

Decrease the torque by 20% when using thread lubricant  
The torque tolerance is  $\pm$  on torque values.

+

C2000/9905

## HYDRAULIC TORQUE REQUIREMENTS

### HYDRAULIC TORQUE REQUIREMENTS

Refer to the following chart for torque values on all hydraulic hoses and fittings.

Nominal SAE Dash Size	O-Ring Face Seal End		SAE O-Ring Boss End	
	Thread Size Inch	Swivel Nut Torque	Thread Size Inch	Str. Fitting or Locknut Torque
		LB-FT		LB-FT
-3	*	*	3/8-24	8-10
-4	9/16-18	10-12	7-16-20	14-16
-5	*	*	1/2-20	18-20
-6	11/16-16	18-20	9/16-18	24-25
-8	13/16-16	32-35	3/4-16	50-60
-10	1-14	46-50	7/8-14	72-80
-12	1 3/16-12	65-70	1 1/16-12	125-135
-14	1 3/16-12	65-70	1 3/16-12	160-180
-16	1 7/16-12	92-100	1 5/16-12	200-220
-20	1 11/16-12	125-140	1 5/8-12	210-280
-24	2-12	150-165	1 7/8-12	270-360

\* O-Ring face seal type end not defined for this tube size.

**NOTE**

**Parts must be lightly oiled with hydraulic fluid.**

C-2002

**DECIMAL - METRIC CONVERSION TABLE**

FRACTION	DECIMAL	MILLIMETER	FRACTION	DECIMAL	MILLIMETER
$\frac{1}{64}$	0.015625	0.3969	$\frac{33}{64}$	0.515625	13.0969
$\frac{1}{32}$	0.03125	0.7938	$\frac{17}{32}$	0.53125	13.4938
$\frac{3}{64}$	0.046875	1.1906	$\frac{35}{64}$	0.546875	13.8906
$\frac{1}{16}$	0.0625	1.5875	$\frac{9}{16}$	0.5625	14.2875
$\frac{5}{64}$	0.078125	1.9844	$\frac{37}{64}$	0.578125	14.6844
$\frac{3}{32}$	0.09375	2.3813	$\frac{19}{32}$	0.59375	15.0813
$\frac{7}{64}$	0.109375	2.7781	$\frac{39}{64}$	0.609375	15.4781
$\frac{1}{8}$	0.125	3.1750	$\frac{5}{8}$	0.625	15.8750
$\frac{9}{64}$	0.140625	3.5719	$\frac{41}{64}$	0.640625	16.2719
$\frac{5}{32}$	0.15625	3.9688	$\frac{21}{32}$	0.65625	16.6688
$\frac{11}{64}$	0.171875	4.3656	$\frac{43}{64}$	0.671875	17.0656
$\frac{3}{16}$	0.1875	4.7625	$\frac{11}{16}$	0.6875	17.4625
$\frac{13}{64}$	0.203125	5.1594	$\frac{45}{64}$	0.703125	17.8594
$\frac{7}{32}$	0.21875	5.5563	$\frac{23}{32}$	0.71875	18.2563
$\frac{15}{64}$	0.234375	5.9531	$\frac{47}{64}$	0.734375	18.6531
$\frac{1}{4}$	0.25	6.3500	$\frac{3}{4}$	0.75	19.0500
$\frac{17}{64}$	0.265625	6.7469	$\frac{49}{64}$	0.765625	19.4469
$\frac{9}{32}$	0.28125	7.1438	$\frac{25}{32}$	0.78125	19.8438
$\frac{19}{64}$	0.296875	7.5406	$\frac{51}{64}$	0.796875	20.2406
$\frac{5}{16}$	0.3125	7.9375	$\frac{13}{16}$	0.8125	20.6375
$\frac{21}{64}$	0.328125	8.3344	$\frac{53}{64}$	0.828125	21.0344
$\frac{11}{32}$	0.34375	8.7313	$\frac{27}{32}$	0.84375	21.4313
$\frac{23}{64}$	0.359375	9.1281	$\frac{55}{64}$	0.859375	21.8281
$\frac{3}{8}$	0.375	9.5250	$\frac{7}{8}$	0.875	22.2250
$\frac{25}{64}$	0.390625	9.9219	$\frac{57}{64}$	0.890625	22.6219
$\frac{13}{32}$	0.40625	10.3188	$\frac{29}{32}$	0.90625	23.0188
$\frac{27}{64}$	0.421875	10.7156	$\frac{59}{64}$	0.921875	23.4156
$\frac{7}{16}$	0.4375	11.1125	$\frac{15}{16}$	0.9375	23.8125
$\frac{29}{64}$	0.453125	11.5094	$\frac{61}{64}$	0.953125	24.2094
$\frac{15}{32}$	0.46875	11.9063	$\frac{31}{32}$	0.96875	24.6063
$\frac{31}{64}$	0.484375	12.3031	$\frac{63}{64}$	0.984375	25.0031
$\frac{1}{2}$	0.5	12.7000	1	1.0000	25.4000

C-2001/9907

## MACHINE PREPARATION

---



Figure 1

YOUR SMART 2000 MACHINE HAS BEEN SHIPPED COMPLETE, BUT DO NOT ATTEMPT TO OPERATE WITHOUT FOLLOWING THESE INSTRUCTIONS.

### PREPARING THE MACHINE FOR OPERATION (IC Engine Powered)

1. Connect and tighten battery cables.
2. Fill the tank with REGULAR GRADE gasoline. (Diesel fuel if equipped with diesel engine.)



### **WARNING**

**Never fill the tank while the engine is running. Always be sure the gasoline container and sweeper are electrically connected before pouring gasoline. This can easily be done by providing an insulated wire (permanently attached to container) with a battery clip on the other end.**

3. Check engine crankcase oil level. Although properly lubricated at the factory, check before starting the engine. No special break in oil is used and recommended number of operating hours before the initial oil change is the same as normal. See Maintenance.
4. Check radiator coolant level. Permanent type antifreeze is added at the factory to provide protection to approximately -35°F (37°C). To retain this protection level, always add ½ part water to ½ part antifreeze.
5. Check oil level in the hydraulic reservoir located at the drivers side of the machine beside the engine. The oil fill level should be halfway on sight glass. If oil is needed, add Standard, 30 weight, non-detergent motor oil. After the first 50 operating hours, service must be performed on your engine to ensure future high performance and trouble free operation. See Maintenance.

### NOTE

After the first 35 operating hours, service must be performed on your engine to ensure future high performance and trouble free operation. See Maintenance.

### BATTERY POWERED MACHINES

\*Uncrate the machine and carefully remove from skid to prevent damage.

\*The SMART 2000 machines that are shipped without batteries have the (+) positive drive motor lead disconnected.

\*Open the battery compartment and connect the (+) positive motor lead to the top terminal post (the wire "P" is also attached to it). Tighten the terminal nut.

\*Install the scrub brushes.

\*Check the oil level in the hydraulic reservoir

\*Install batteries as follows (if not included):

1. Turn the key to the "OFF" position.
2. Raise the Front Cover to the open position.
3. Use a battery lifting device with a 2500 lbs. (1150 Kg) capacity hoist to lift the battery. Set up the battery tray in the center position. Make sure the size of the battery fits into the tray prior to installation (20.25W x 38.50 x 31.00 L).
4. Using the lifting device, lower the 36 volt battery into the battery tray directly in front of the driver's compartment. Orient the cables & plug them in as required.
5. Plug the polarized connector from the battery into the 36 volt plug provided.



### WARNING

Hydrogen gas is formed during the charging operation and is explosive! Only charge batteries in a well ventilated area with the lid open. Avoid any open flame or electrical sparks. Pulling out the charger plug with the timer on will cause an arc and must be avoided.

## **SAFETY INSTRUCTIONS**

---

THE FOLLOWING STATEMENTS ARE USED THROUGHOUT THIS MANUAL AS INDICATED IN THEIR DESCRIPTIONS:

 **DANGER**

To warn of immediate hazards which will result in severe personal injury or death.

 **WARNING**

To warn of hazards or unsafe practices which could result in severe personal injury or death.

 **CAUTION**

To warn of hazards or unsafe practices which could result in minor personal injury.

**ATTENTION**

To warn of unsafe practices which could result in extensive equipment damage.

**NOTE**

To give important information or to warn of unsafe practices which could result in equipment damage.

 **WARNING**

THE FOLLOWING INFORMATION SIGNALS POTENTIALLY DANGEROUS CONDITIONS TO THE OPERATOR OR EQUIPMENT. READ THIS MANUAL CAREFULLY. KNOW WHEN THESE CONDITIONS CAN EXIST. THEN, TAKE NECESSARY STEPS TO TRAIN MACHINE OPERATING PERSONNEL. FOR THE SAFE OPERATION OF THIS MACHINE, READ AND UNDERSTAND ALL WARNINGS, CAUTIONS AND NOTES.

 **WARNING**

Machines can ignite flammable materials and vapors. Do not use with or near flammables such as gasoline, grain dust, solvents, and thinners.

 **WARNING**

Improper use of heavy machinery can cause personal injury.

 **WARNING**

Operate only when lids, doors, and access panels are securely closed.

 **WARNING**

Use care when reversing machine in confined area.

 **WARNING**

When servicing the machine, disconnect the batteries first to prevent possible injury.

 **WARNING**

When working on the machine, empty hopper, remove batteries, clear area of people and obstructions, use additional people and proper procedures when lifting the machine.

 **WARNING**

Always empty the hopper and disconnect the battery before doing maintenance.

 **WARNING**

You must have training in the operation of this machine before using it. READ THE INSTRUCTION BOOK.

 **WARNING**

Do not operate this machine unless it is completely assembled.

 **WARNING**

Do not use this machine as a step or furniture.

 **WARNING**

Stop and leave this machine on a level surface. When you stop the machine, put the power switch in the "OFF" position and engage the Wheel Lock.

 **WARNING**

To prevent injury and damage to the machine, do not lift the machine or move it to an edge of a stair or loading dock.

 **WARNING**

Lead acid batteries generate gases which can cause an explosion. Keep sparks and flames away from batteries. **NO SMOKING.** Charge batteries only in areas with good ventilation.

 **WARNING**

Always wear eye protection and protective clothing when working near batteries. Remove all jewelry. Do not put tools or other metal objects across the battery terminals or across the tops of batteries.

 **WARNING**

Maintenance and repairs must be done by authorized personnel only. Tighten all fasteners. Maintain adjustments according to the specifications given in the service manual for the machine. Keep the electrical parts of the machine dry. For storage, keep the machine in a building.

 **WARNING**

Make sure all labels, decals, warnings, cautions and instructions are fastened to the machine. Purchase new labels and decals from American-Lincoln Technology.

 **WARNING**

The operator must exhibit extreme caution when negotiating, turning, and traveling across grades or ramps. Start, stop, change direction, travel and brake smoothly. Slow down when turning.

 **WARNING**

Avoid uneven surfaces and loose materials. Watch for obstructions, especially overhead.

 **WARNING**

Operate only from the designated operator's position. Stay inside the body of the machine. Keep hands and feet on the designated controls. Always operate in well lighted areas.

 **WARNING**

Do not carry passengers on the machine. Set the Wheel Lock when leaving the machine. Chock (block) the wheels if the machine is parked on a grade (ramp), or is being prepared for Maintenance.

 **WARNING**

Never leave the operator's compartment when the is engine running.

 **WARNING**

Report damage or faulty operation immediately. Do not operate the machine until repairs have been completed. Maintenance and repairs must be done by authorized personnel only.

 **WARNING**

To maintain the stability of this machine in normal operation, the overhead guard, counterweights, roller bumper guards, or any similar equipment installed by the manufacturer as original equipment should never be removed. If it becomes necessary to remove such equipment for repair or maintenance, this equipment must be reinstalled before the machine is placed back into operation.

 **WARNING**

Electrical hazard. Shocks can cause serious personal injury. Unplug the battery before cleaning or servicing. To avoid possible injury or property damage, read the Operator's Manual before servicing the machine. Maintenance and repair must be done by authorized personnel.

 **WARNING**

Disconnecting the battery connector with the key switch in the "I" position will cause sparks that could ignite explosive hydrogen gas generated by the batteries. To prevent serious injury or possible property damage, turn Key Switch to "O" position before disconnecting the battery cable from the machine for charging or service.

## **SAFETY INSTRUCTIONS**

---



**FOR SAFETY, OBSERVE THE FOLLOWING WARNINGS. FAILURE TO COMPLY MAY CREATE A SERIOUS RISK OF INJURY TO YOURSELF AND OTHERS. THIS MACHINE SHOULD NOT BE USED IN HAZARDOUS LOCATIONS INCLUDING AREAS OF VOLATILE DUST OR VAPOR CONCENTRATIONS.**

**Operators must be trained and qualified to operate this machine. They must also understand the operator's manual before starting.**

**Use caution when mounting or dismounting the machine particularly on wet slippery surfaces. Do not dump the hopper over an open pit or dock. Do not dump the hopper when positioned on a grade (ramp). The machine must be level (horizontal).**

## OPERATION OF CONTROLS AND GAUGES

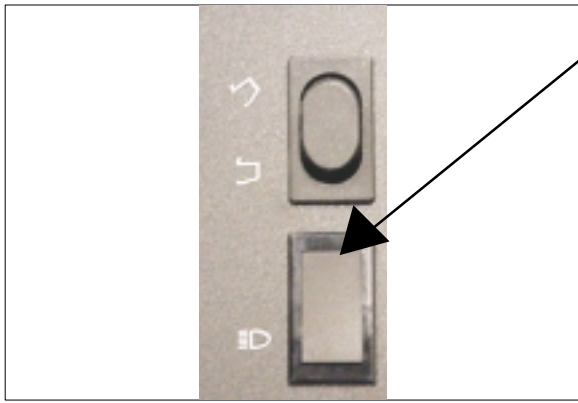

Figure 2

### LIGHT SWITCH (See Figure 2)

The light switch is located above the horn button to the left of the steering wheel. By pressing on the lower part of the switch, it will work various light options that are available for this machine, such as:

- Headlights
- Taillights

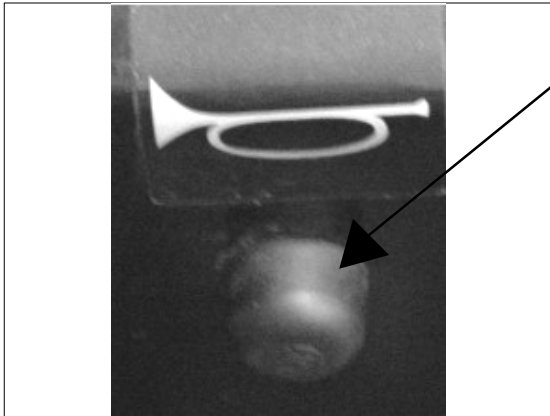

Figure 3

### HORN BUTTON (See Figure 3)

The horn button is located to the left of the steering column below the instrument panel. The horn button is always active.



Figure 4

### KEY SWITCH (See Figure 4)

The keyed ignition switch is located on the instrument panel to the right of the broom lever.

The "OFF" position (O position) will shut off the engine. The IGN/ON position (I position) provides power to all machine systems and accessories. The "START" position (one position clockwise of I position) is momentary and provides power to the starter motor.

#### NOTE

To reengage, the key must be returned to the "OFF" position.



Figure 5

### HOUR METER (See Figure 5)

The hour meter is located on the instrument panel below the fuel gauge (gas version), below the battery condition meter (battery version). The meter is activated when the key switch is placed in the ignition position. The meter indicates the actual "run" time of the machine. The meter can be used to determine when maintenance should be done on the machine.

## OPERATION OF CONTROLS AND GAUGES - Cont.

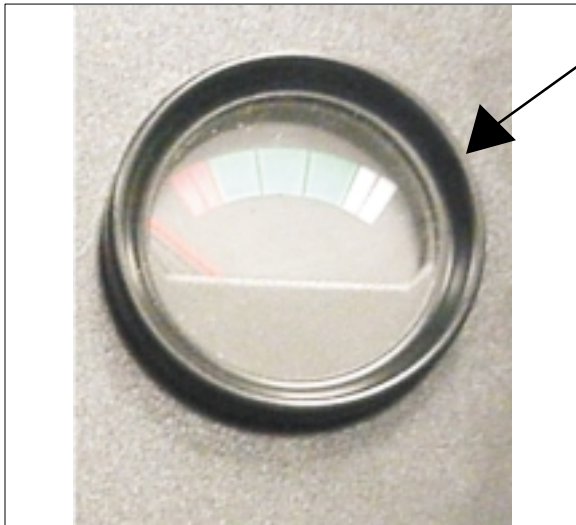

Figure 6

### **BATTERY CONDITION METER (See Figure 6)**

The battery condition meter is located on the right side of the instrument panel. The condition meter indicates the level of charge in the batteries (inspect underload). The batteries are sufficiently charged when the needle stays in the green area on the gauge while the machine is being operated.

Charge the batteries when the needle drops into the red zone while operating the machine. Do not operate the machine if the needle stays in the red area.

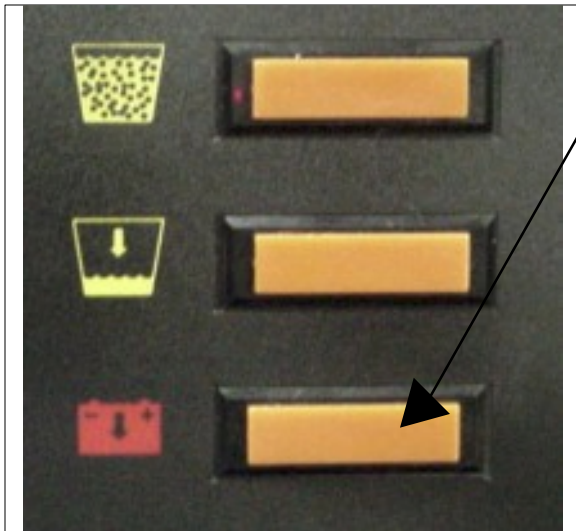

Figure 7

### **BATTERY CONDITION LIGHT (See Figure 7)**

The meter shows the condition of the battery, while the machine is running, under load. When the battery voltage falls below 31-32 volts for longer than 2-3 seconds the low voltage light will come on and the Brush/Water solenoids will be shut off automatically. This is a permanent lockout until the power is turned off to module. The low voltage lock out can be reset almost immediately by turning off all power to the module for 3-5 seconds. In a permanent low battery condition, the machine can be functional only for one minute periods and then only by turning the ignition off and on.

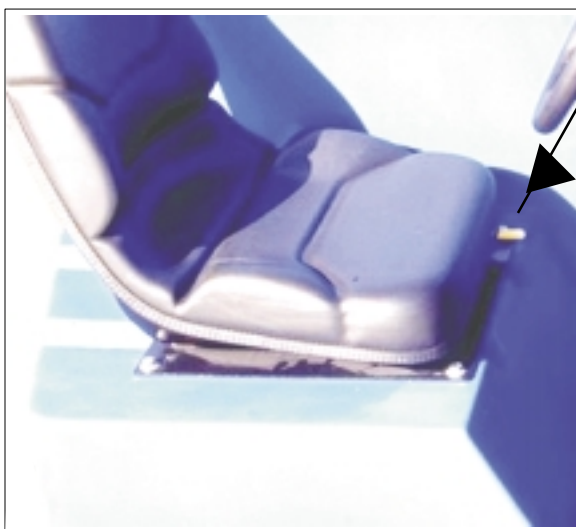

Figure 8

### **SEAT POSITION ADJUSTMENT (See Figure 8)**

The seat position adjustment lever is located on the front of the seat to the left. The lever is spring loaded to the "LOCK" position.

To adjust the seat, push the lever to the "RIGHT" and move the seat to the desired position. Then release the lever to "LOCK" the seat into place.

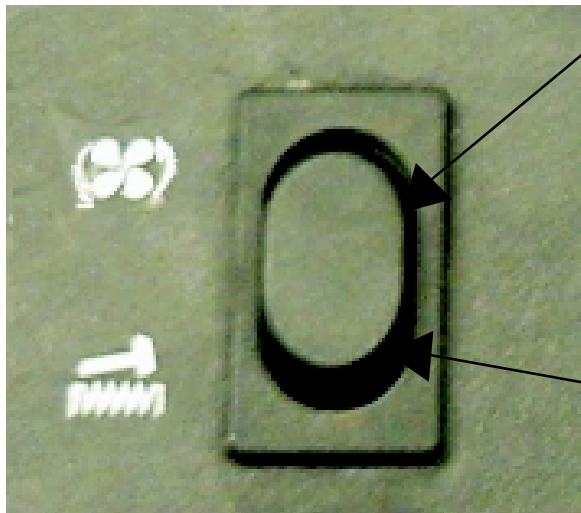

Figure 9

### **FILTER SHAKER SWITCH (See Figure 9)**

The filter shaker switch is located on the top left corner of the instrument panel. By pressing and holding in the lower part of the switch, it will activate the filter shaker motors for 20 to 30 seconds. Upon releasing the switch, it will return to the off (middle) position.

The Impeller fan will stop when the filter shaker has been activated. The filter shaker will only operate with the hopper in the "DOWN" position.

### **DUST CONTROL SWITCH (See Figure 9)**

The Dust Control Switch located on the top left corner of the instrument panel. To turn on the dust control system for "NORMAL" sweeping, press in the upper portion of the switch. To turn off the dust control system for sweeping in wet conditions, return the switch to the middle position (wet sweep bypass). This will prevent the filter from being damaged by water pickup while sweeping.

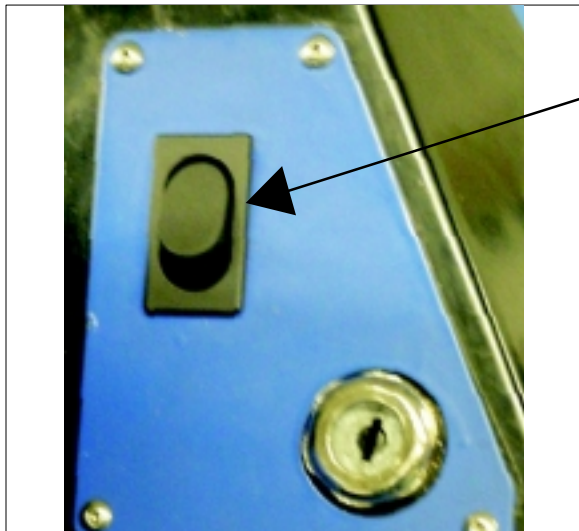

Figure 10

### **SIDE BROOM and MAIN BROOM SWITCH (See Figure 10)**

The Side and Main Broom Switch is located to the right of the steering column. By pressing in the upper portion of the switch, the side and main broom are raised and turned off. To lower and turn on both brooms, press the lower portion of the switch.

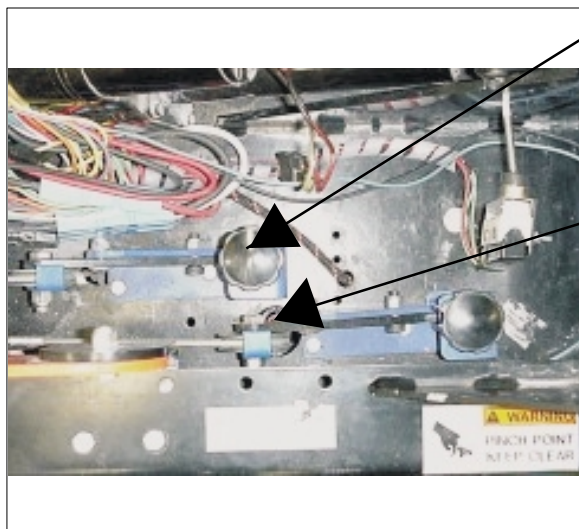

Figure 11

### **MAIN BROOM ADJUSTMENT (See Figure 11)**

The main broom adjustment knob for changing the sweep height to compensate for broom wear, is located in front of the machine to the right of the filter. Turning the knob to the left (counterclockwise) will lower the main broom.

### **SIDE BROOM ADJUSTMENT (See figure 11)**

The side broom adjustment knob for changing the sweep height to compensate for broom wear, is located in front of the machine to the right of the filter. Turning the knob to the left (counterclockwise) will lower the side broom.

## OPERATION OF CONTROLS AND GAUGES - Cont.

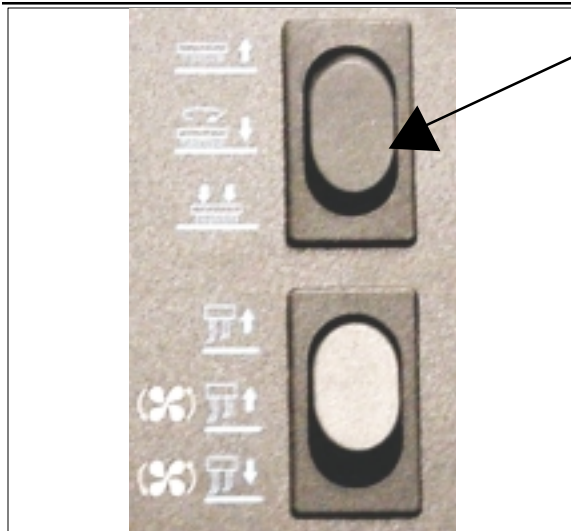

Figure 12

### SCRUB DECK SWITCH (See Figure 12)

The scrub deck switch is located on the instrument panel to the left of the solution control knob. Pressing in the upper portion of the switch raises the scrub deck and turns the brush. In the middle position, the scrub deck lowers to the normal down position. Pressing the lower portion of the switch lowers the scrub deck to the heavy down position.

In the third position, Scrub Deck Heavy, additional downward pressure is applied. This will help for extremely dirty surfaces.

#### NOTE

**Lowering the scrub deck does not turn on the brushes. The brushes turn on automatically when the machine moves in the forward or reverse direction.**

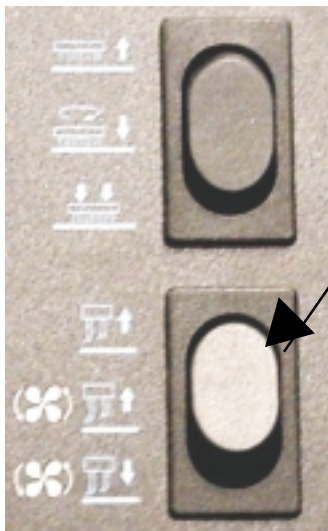

Figure 13

### SQUEEGEE SWITCH (See Figure 13)

The squeegee blade switch is located on the console to the left of the steering wheel. Pressing the lower portion of the switch will lower the squeegee and activate the squeegee vacuum. Pressing the upper portion of the switch will turn off the squeegee vacuum and raise the squeegee.

In the middle position the switch will raise the squeegee. In this position the vacuum remains on to allow vacuuming the water that is left in the squeegee recovery hose. This prevents water from dripping on the floor with the squeegee "UP."

If the squeegee is lowered and the direction of the machine is reverse (activated by the FWD/REV pedal) the squeegee will automatically raise.

Upon moving in the forward position, the squeegee will automatically return to the lowered position.

### SOLUTIONS CONTROL KNOB (See Figure 14)

The solution control knob is located to the left hand side of the steering wheel. Turning the knob counterclockwise will increase the flow of solution and water. The farther the solution control knob is turned the heavier the flow of water and solution will be. Turning the knob counterclockwise will decrease the flow of the water and solution. To turn the water and solution off turn the knob all the way counterclockwise.

#### NOTE

**For best results, discontinue application of solution 10 feet before stopping or making a 90° or 180° turn.**

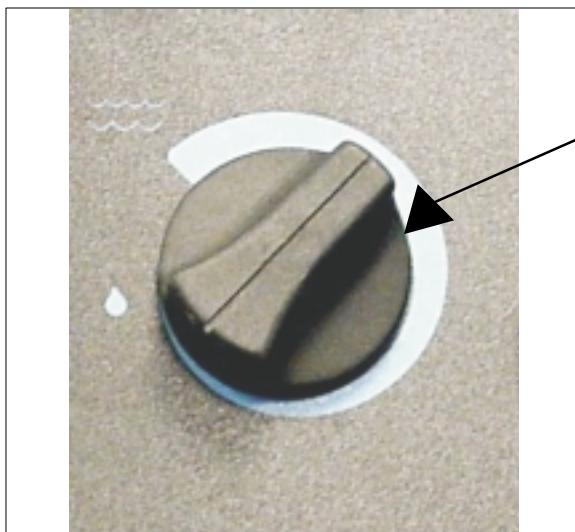

Figure 14

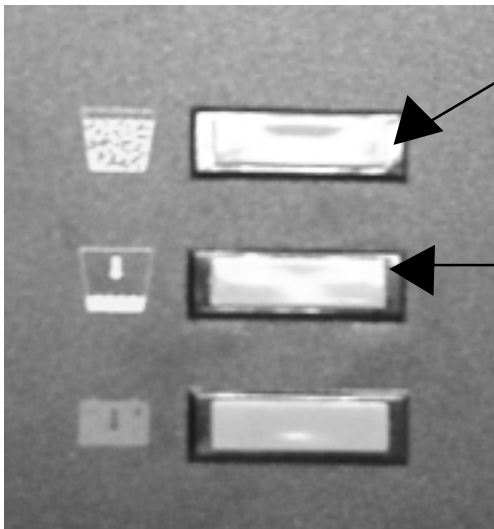

Figure 15

**RECOVERY HIGH LIGHT (See Figure 15)**

The recovery high warning light will illuminate approximately 5 minutes before the recovery tank is full, giving ample time to complete the scrubbing cycle, before the mechanical float shuts off the vacuum to the recovery tank.

**LOW SOLUTION LIGHT (See Figure 15)**

The Low Solution Warning Light is located on the console. The Solution Warning Light will illuminate when the solution tank is empty, marking the end of the scrubbing cycle.

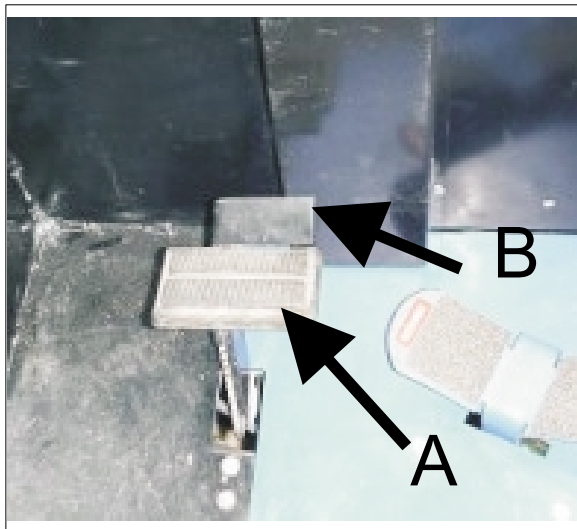

Figure 16

**PARKING BRAKE (See Figure 16)**

Never leave operator's seat without engaging the parking brake. The parking brake is located on the floor of the machine left of the directional control pedal. To set the parking brake, press down on the foot pedal (Item A) and the press down the lock (Item B). To unlock the parking brake, push down on the upper portion of the foot pedal and release.

**TURN SIGNAL - 4-Way (Option)**

The turn signal option is located on the steering column and works as automotive turn signals work, forward on the lever for right and back on the lever for left. The 4-way flasher will activate when the turn signal lever is pulled out.

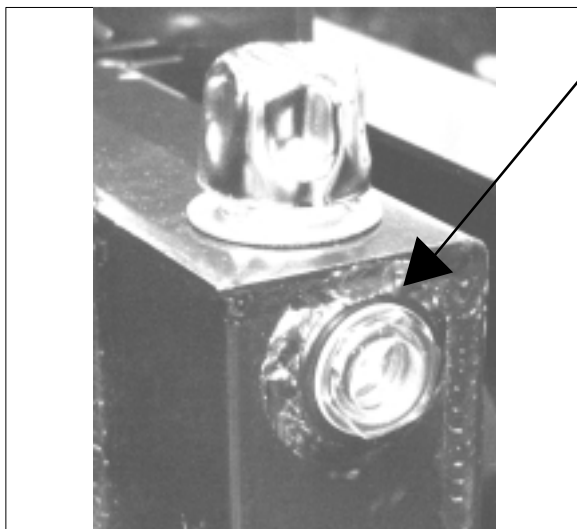
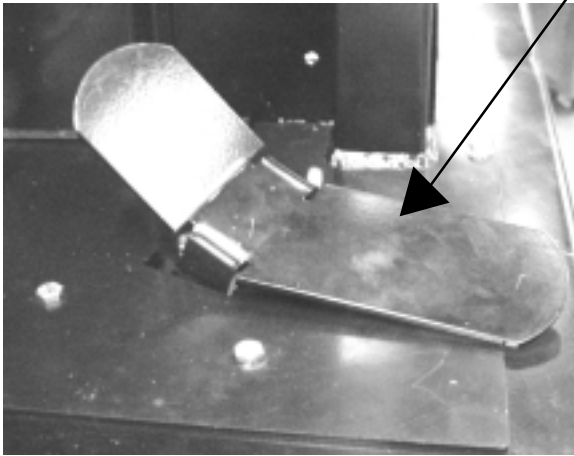

Figure 17

**HYDRAULIC RESERVOIR LEVEL SIGHT GAUGE (See Figure 17)**

The sight gauge is located on the left side of the machine under the front cover. The sight gauge is used to indicate the level of fluid in the reservoir. The fluid level must be visible in the sight gauge when the hopper is in the down position.

**ACCELERATOR and DIRECTIONAL CONTROL PEDAL - (See Figure 18)**



The Accelerator and Directional Control Pedal is located on the floor of the operator's area. This pedal controls the machine direction and travel speed.

1. Put foot pressure on the right side of the pedal. The machine will move forward.
2. Increase the foot pressure on the right side of the pedal to increase the forward speed.
3. Put foot pressure on the left side of the pedal. The machine will move in reverse.
4. Increase the foot pressure on the left side of the pedal to increase the reverse speed.
5. To stop the machine, allow directional control pedal to return to neutral (center position). Pedal will automatically return to neutral when foot pedal is released, or put light foot pressure on the opposite end of the accelerator and directional control pedal. If the machine is moving forward, put light foot pressure on the left side of the pedal. If the machine is moving in reverse, put light foot pressure on the right side of the pedal.

Figure 18

**BACK-UP ALARM SWITCH (Option)**

The back-up alarm is operated by a switch that is located under the accelerator and directional control pedal mounting plate. The alarm makes a loud audible noise when the machine is being driven in reverse.

**FILTER PANEL KNOB (See Figure 19)**

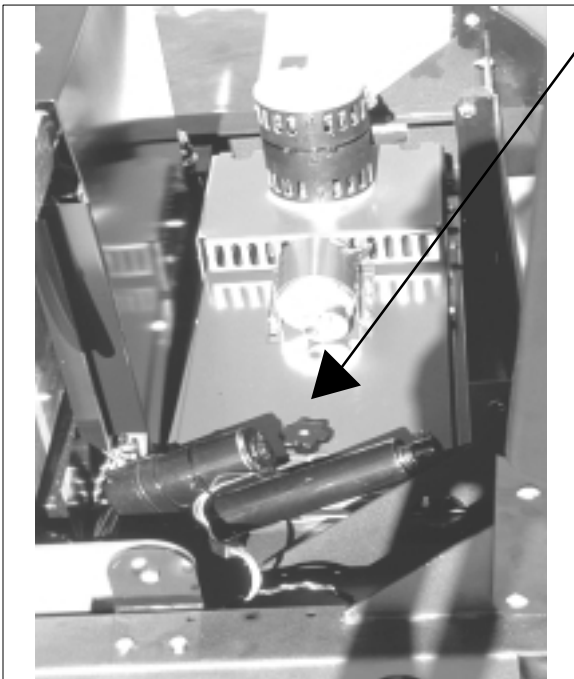

The filter panel knob is used to hold the dust control filter down. It is located in the hopper filter compartment and will need to be removed periodically for cleaning or replacement. Removal of the filter panel requires no tools. The hopper cover must be opened to gain access to the filter compartment. The panel filter is held in place by a hinged frame and knob.

To remove the panel filter, turn the knob counterclockwise and lift the hinged frame. The panel filter can now be lifted out and cleaned or replaced.

To install the replacement panel filter, place a new filter in the machine, lower the frame and twist the knob clockwise to lock the filter in place.

Figure 19

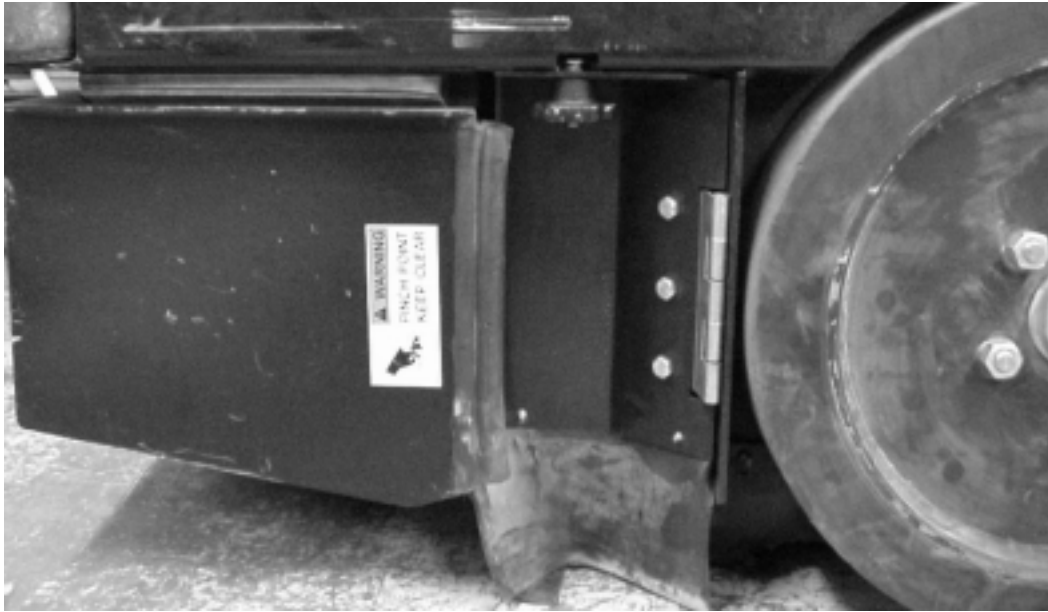

Figure 20

**MAIN BROOM COMPARTMENT DOOR (See Figure 20)**

The main broom compartment door is located in front of the left side tire of the machine. The door provide access to the main broom for service or inspection. The hopper must be raised to access.

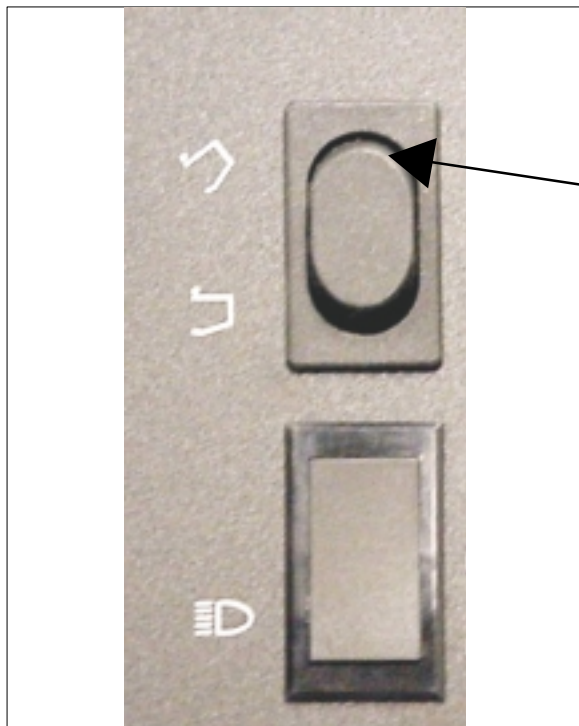

Figure 21

**WARNING**

Engage hopper safety arm while accessing the main broom.

**HOPPER LIFT SWITCH (See Figure 21)**

The hopper lift switch is located on the operator's compartment console. The switch controls the operation of the hopper lift system.

To raise the hopper for dumping, press and hold the upper portion of the switch until the hopper reaches the desired height or a ratcheting sound is heard, then release.

**NOTE**

While the hopper is open a chime will ring letting the operator know it is open. The chime will stop when the hopper is completely closed.

To close the hopper press in and hold the lower portion of the switch until the hopper closes completely (chime will turn off) then release.

## ESP SYSTEM OPERATING INSTRUCTIONS

### THE SCRUBBING SYSTEM - HOW IT WORKS

There are two scrubbing systems available for the SMART 2000 machine, the non-recycling or standard scrubbing system and the recycling or ESP scrubbing system.

### THE NON-RECYCLING OR STANDARD SCRUBBING SYSTEM - HOW IT WORKS

During the scrubbing process, detergent solution water from the solution tank is fed to the solution line. There it is fed to the floor where three disc scrubbing brushes work to dislodge soil. After scrubbing, the dirty solution is vacuumed from the floor and discharged into the containment chamber in the forward portion of the recovery tank, where a system of baffles helps to clarify the solution.

Sensors in each tank will indicate, by lights on the control panel, when the water in the solution tank is too low or when the water in the recovery tank is too high.

### THE ESP RECYCLING SYSTEM ON/OFF SWITCH (Option)

This switch turns the ESP recycling system on and off.

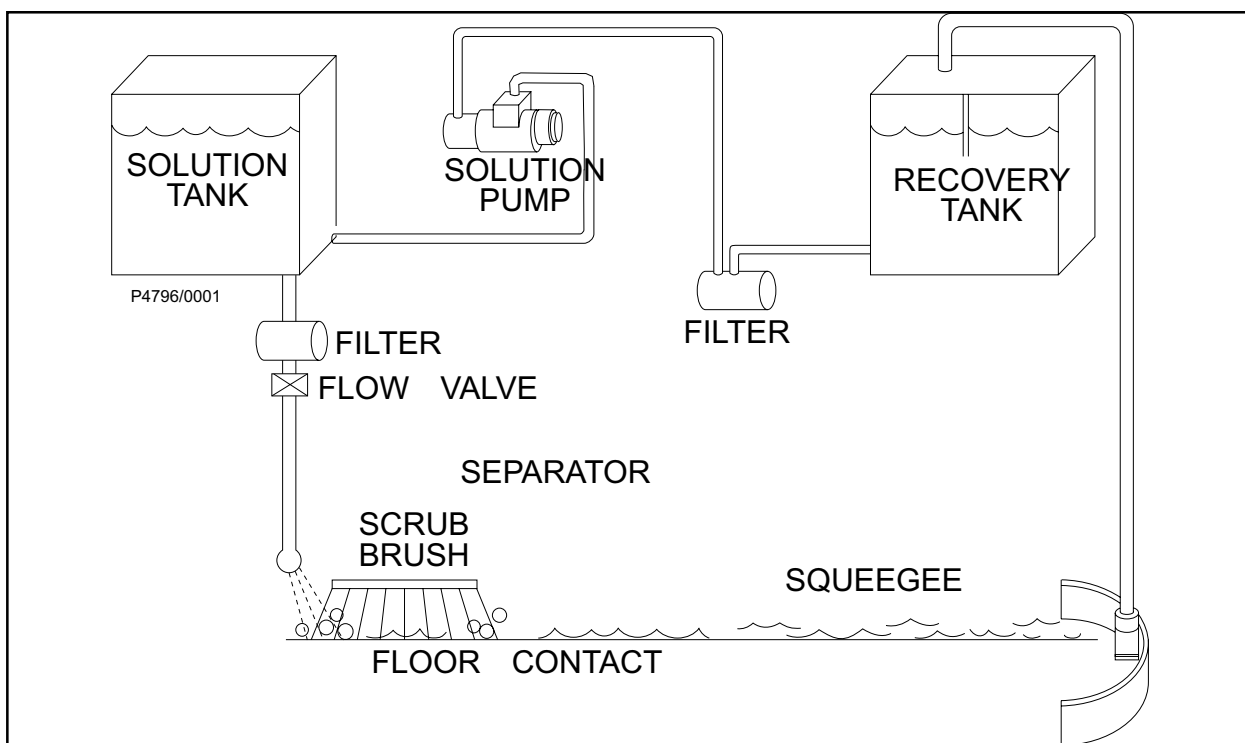

Figure 22

### NOTE

The solution control lever must be on "FULL" for ESP operation.

### THE RECOVERY OR ESP SYSTEM - HOW IT WORKS

During the scrubbing process, filtered water from the solution tank is fed to the solution line, where it combines with detergent. This mixture is then fed to the floor where three disc scrubbing brushes work to dislodge soil. After scrubbing, the dirty solution is vacuumed from the floor and discharged into the recovery tank. At intervals, a float switch activates the recycling pump, which sends filtered solution from the recovery tank to the solution tank.

## BEFORE STARTING THE MACHINE

1. Set parking brake.
2. Make sure all controls are in the "OFF" position.
3. Be sure the directional control pedal is in neutral.
4. Ensure the batteries have been fully charged and serviced (see battery service instructions).

### NOTE

Before starting the engine, perform the pre-start checklist.

## PRE-START CHECKLIST

1. Clean engine air filter element.
2. Check hydraulic fluid level.
3. Check all systems for leaks.
4. Check brakes and controls for proper operation.
5. Check broom patterns.
6. Check to ensure that all covers, panels and access doors are securely closed.

### NOTE

To prevent possible fire, never fill fuel tank while the engine is running. Always be sure gasoline container and machine are grounded before dispensing gas. This can be done by permanently attaching an insulated wire with a battery clip on the end to the gasoline container.

## STARTING BATTERY MACHINES

Starting the battery powered models is accomplished by turning the key switch to the "I" (on) position. It is important to note that the batteries should be fully charged and serviced prior to using the machine.

### NOTE

After turning off the machine, perform these post-operation checks.

## POST-OPERATION CHECKLIST

1. Clean the debris hopper.
2. Check sweeping brooms for wear or damage.
3. Check all flaps for wear, damage and adjustment.
4. Check all systems for leaks.
5. Charge and service motive power batteries.
6. Check squeegees for damage.

## SERVICE CHART

---

### SERVICE CHART

Check items for proper operation. If service is required, please contact an authorized American-Lincoln Technology distributor. For best performance, replace worn parts with genuine American-Lincoln Technology parts.

#### **EVERY eight (8) HOURS or DAILY check and clean/adjust if necessary:**

- 1 Inspect panel filters for damage and clean them.
- 2 Inspect and clean hopper.
- 3 Inspect and clean recovery tank screens and filters.
- 4 Check hydraulic fluid level.
- 5 Check all flaps for wear or damage.
- 6 Check brooms for wear or damage, adjust as required.
- 7 Check brake pedal and parking brake.
- 8 Check hydraulic oil filter.
- 9 Check battery electrolyte level.
- 10 Check all fluid system components for leaks.

#### **50 HOUR (WEEKLY) MAINTENANCE CHECKLIST**

- 11 Check solution tank (recycling or ESP system).
- 12 Check solution filter screen (recycling or ESP system).
- 13 Check recovery tank.
- 14 Check recovery tank screens and filters.
- 15 Inspect scrub brushes for wear or damage.
- 16 Inspect rear and side squeegees for wear or damage.
- 17 Check battery electrolyte level.
- 18 Check all hydraulic hoses for wear or cuts.
- 19 Rotate main brush (end over end).
- 20 Clean or replace panel filters.
- 21 Lubricate squeegee casters.
- 22 Clean throttle rod springs

#### **100 HOUR MAINTENANCE CHECKLIST**

- 23 Lubricate drive wheel, swivel wheel bearings, and steering rack guide (engine side above rear wheel).
- 24 Lubricate front wheel bearings.
- 25 Lubricate all moving joints.
- 26 Check brake shoes for wear and adjust accordingly.
- 27 Lubricate all bushings with anti-seize lubricant. The bushings are located on the steering, scrub deck lift, and squeegee lift

#### **250 HOUR MAINTENANCE CHECKLIST**

- 28 Lubricate squeegee casters.
- 29 Clean solution tank and filter screen.
- 30 Replace hydraulic filter element.
- 31 Clean hydraulic reservoir.

SERVICE CHART DIAGRAM

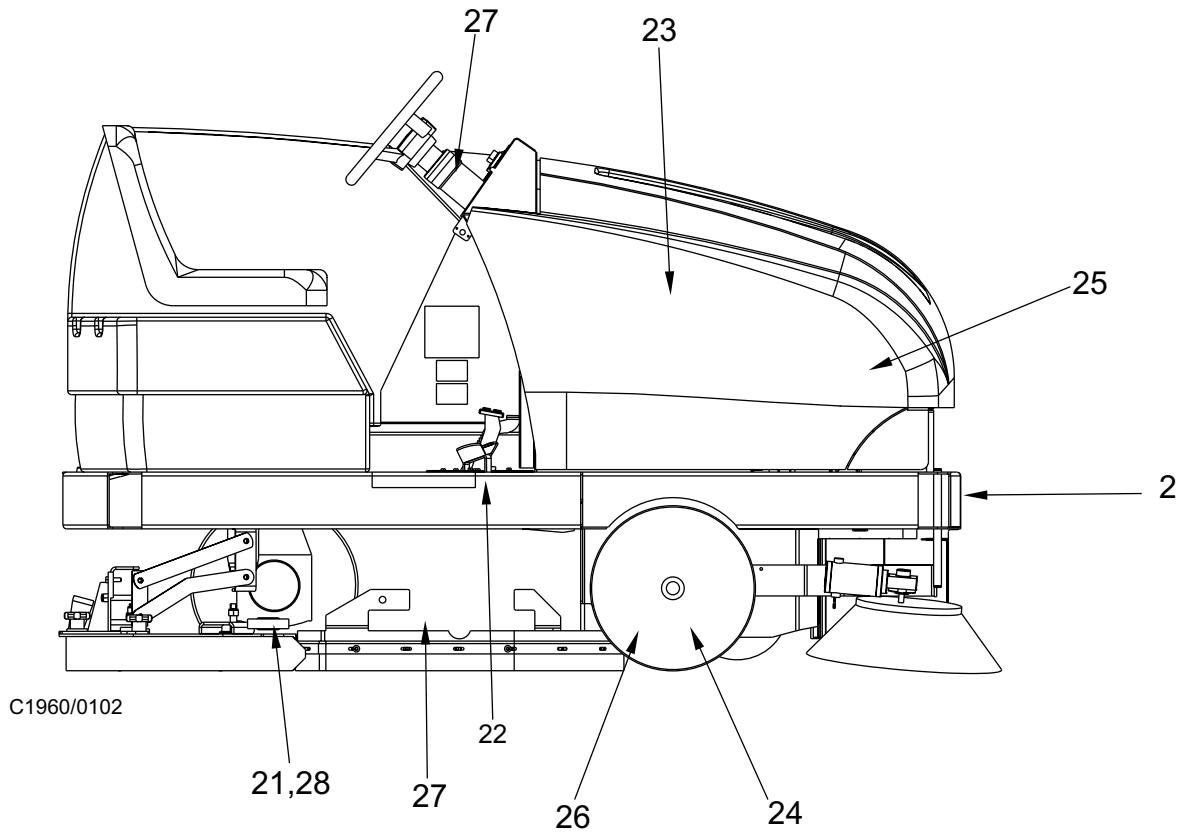
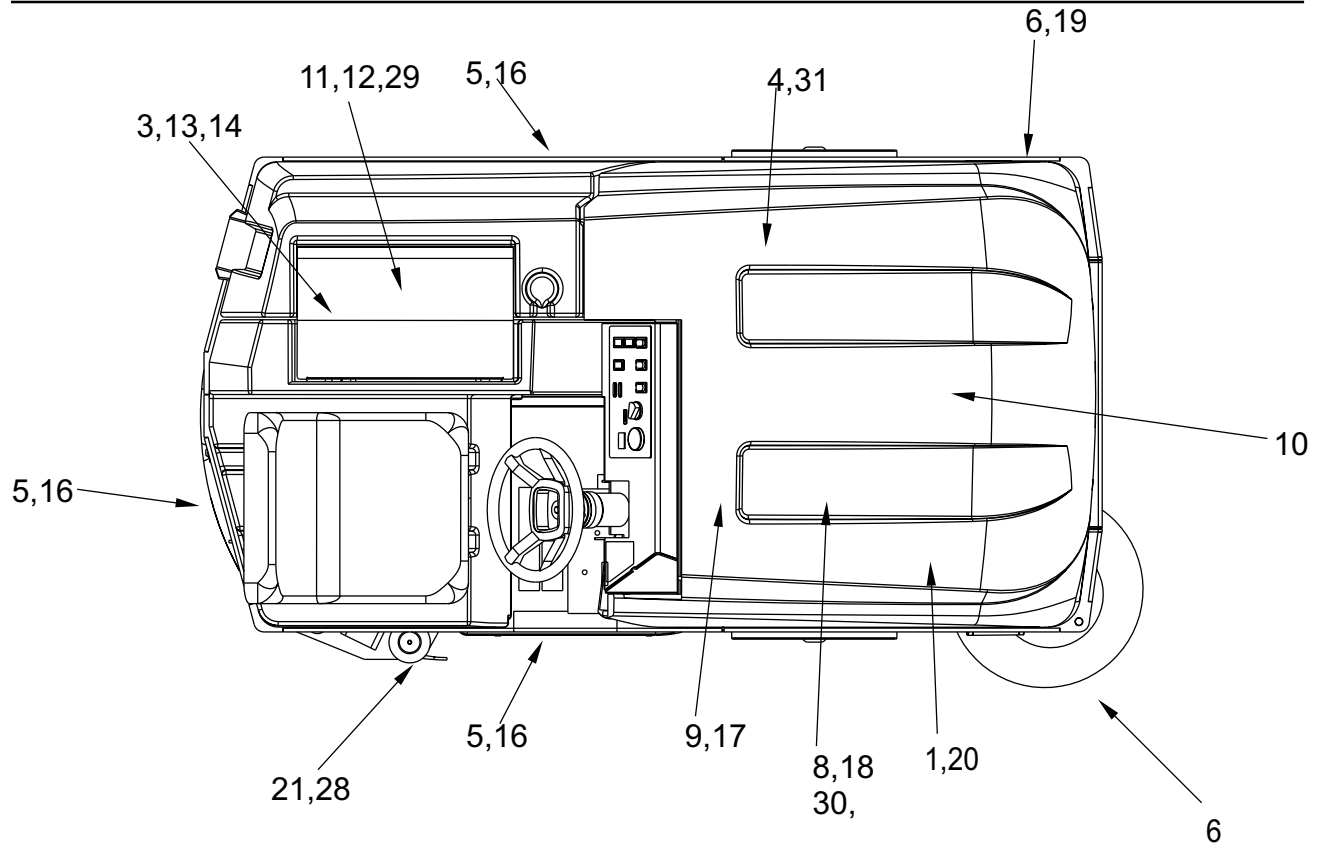

C1960/0102

Figure 23

## HELPFUL HINTS FOR CLEANING OPERATION

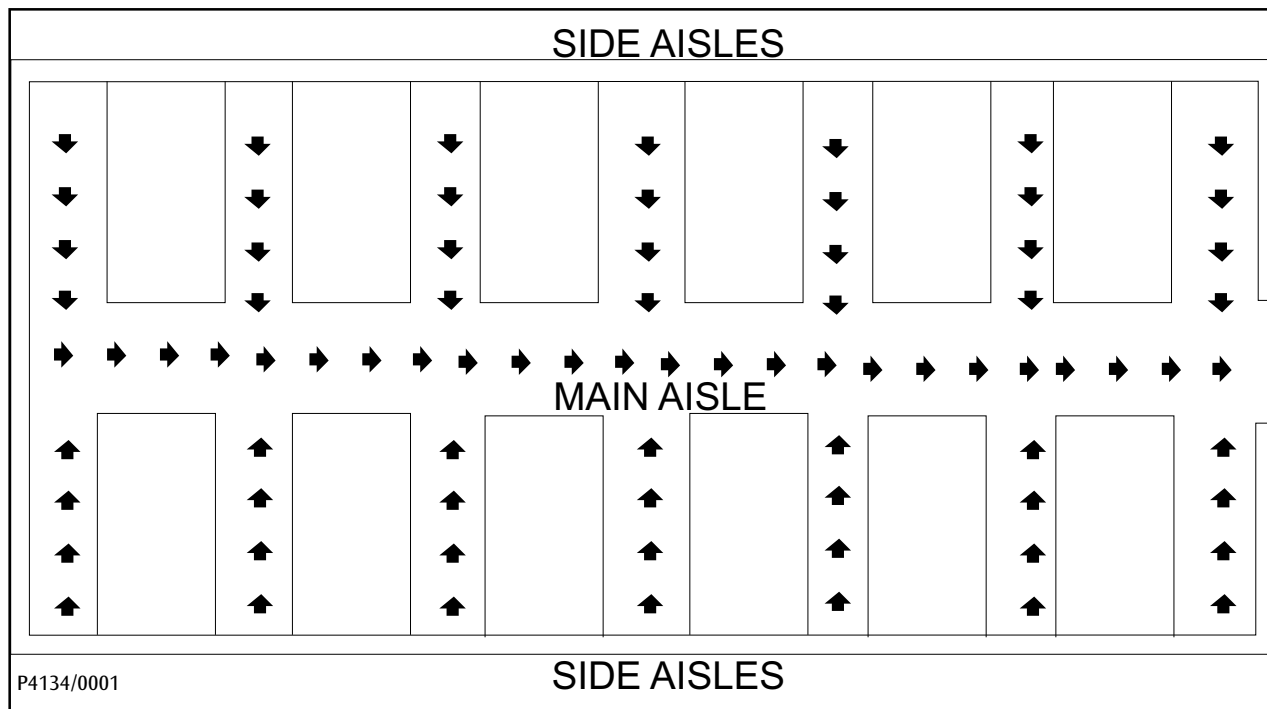

Figure 24



### WARNING

**Do not turn the steering wheel sharply when the machine is in motion. The machine is very responsive to movement of the steering wheel. Do not make sudden turns. Scrub in straight paths. Do not bump posts. Do not scrape the sides of the machine.**

1. Plan your sweeping and scrubbing in advance. Try to arrange long runs with minimum stopping and starting. Sweep debris from narrow aisles out into main aisles ahead of time. Do an entire floor or section at one time.
2. Pick up oversize debris before sweeping.
3. Allow a few inches of overlap of sweep and scrub paths. This will eliminate leaving dirty patches.
4. Do not turn steering wheel too sharply when the machine is in motion. The machine is very responsive to movement of the steering wheel, so avoid sudden turns.
5. Try to follow as straight a path as possible. Avoid bumping into posts or scraping the sides of the machine.
6. Always allow the machine to warm up before operating in cold temperatures.
7. Periodically turn the sweeping broom end-over-end to prevent the bristles from "setting" in one direction.

### NOTE

**Replace the sweeping broom when the bristles are worn to 3 inch (8 cm) length. Replace disc brushes when bristles are reduced to ½ inch (1.3 cm) in length. Replace squeegee rubbers when all usable edges have become rounded with wear, impairing the wiping action.**

## SERVICE PRECAUTIONS

---

For safety, read and follow the service precautions below. Know the hazards associated with the equipment you are working on to prevent personal injury or damage to equipment.

For service assistance, consult your nearest American Lincoln Technology Dealer. For best performance replace worn parts with genuine American Lincoln Technology parts.

Refer all Maintenance and Service requirements to Qualified Maintenance Personnel.



### WARNING

**DO NOT attempt to service this machine until you have read and understand all Safety Warnings associated with the equipment you are working on.**



### WARNING

**Electrical repairs must be done by authorized personnel only. Consult your American-Lincoln Authorized Service Person to do service procedures. Use only genuine American-Lincoln parts.**



### WARNING

**Unexpected movement could cause injury. Always park on a level surface, turn key off, and engage parking brake before working on the machine.**



### WARNING

**Maintenance and repairs must be done by authorized personnel only. Always empty the hopper and disconnect the batteries before doing any maintenance. Keep all fasteners tight. Keep adjustments according to the specifications as shown in the Service Manual for this machine.**



### WARNING

**Always wear eye protection and protective clothing when working near batteries. Do not put tools or other metal objects across the tops of the batteries. NO SMOKING.**



### WARNING

**The hopper could fall and cause serious injury. Always engage the hopper safety arm before working under the hopper.**



### WARNING

**Moving the fan and belt may cause injury. Stay clear of moving parts.**



### WARNING

**Pinch points may cause injury. Stay clear of moving parts.**



### WARNING

**To maintain the stability of this machine in normal operation, the overhead guard, or any similar equipment installed by the manufacturer as original equipment should not be removed. If it becomes necessary to remove such equipment for repair or maintenance, this equipment must be reinstalled before the machine is placed back in operation.**



### WARNING

**To prevent injury or engine damage, do not remove the radiator cap under any conditions while the engine is running or when it is hot. To prevent burns from steam or scalding hot coolant being expelled from the radiator, use extreme care when removing the radiator cap. Wait until the engine has cooled.**

## SERVICE INSTRUCTIONS

### SWEEPING SYSTEM SERVICE

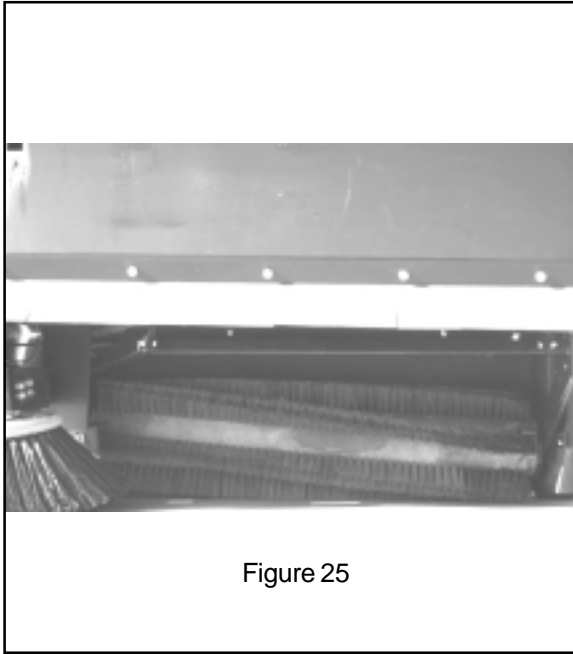

#### MAIN BROOM

To prevent the broom from “setting” in one direction and to provide the maximum life of the broom it is recommended that the broom be turned end over end periodically.

#### ADJUSTING THE MAIN BROOM HEIGHT

When changing the sweep height adjustment it is recommended that the knob be adjusted 1 turn at a time. After adjustment, recheck the sweep pattern to determine if further adjustment is necessary.

Turn the adjustment knob counterclockwise to INCREASE the sweep pattern width.

Turn the adjustment knob clockwise to DECREASE the sweep pattern width.

#### REPLACING THE MAIN BROOM

The Main Broom should be replaced when the bristles become worn to less than 3". The main broom is held in place by the right side broom door. This feature provides for easy removal and installation of the main broom without the need for special tools or equipment. Follow the instructions below for main broom removal & replacement.

1. Park sweeper on a smooth level surface, engage parking brake, turn key switch to “O”, place the main/side broom switch in the “SWEEP” position.
2. Open the main broom door.
3. Swing the broom drive idler hub out to clear the main broom.
4. Remove the broom from the broom compartment.
5. Install the replacement broom. Pay special attention to the slots on the broom, it may be necessary to rotate the broom so the tabs on the drive hub align with the slots on the broom.
6. Swing the idler hub to engage the main broom and close the access door. Check the door latch for proper engagement when closed.
7. Check the Main Broom sweep pattern and adjust as necessary.



Figure 26

### SIDE BROOMS SERVICE



Figure 27

#### SIDE BROOM

The Side Broom sweeping angle is not adjustable however the height of the side brooms can be adjusted to compensate for wear as the broom becomes worn from use. Always check and adjust the sweep pattern after changing the side broom.

#### ADJUSTING THE SIDE BROOM HEIGHT

Turn the side broom adjustment knob to change the side broom sweep height. Recheck for proper sweep pattern after adjustment.

Turn the adjustment knob counterclockwise to INCREASE the sweep pattern width.

Turn the adjustment knob clockwise to DECREASE the sweep pattern width.



Figure 28

#### REPLACING THE SIDE BROOM

Change the side brooms when the bristles become worn to less than 3 inches length.

1. Park the machine on a smooth level surface, turn key switch to "O" Position and engage parking brake.
2. Place the side brooms switch in the "UP" position.
3. Remove the lock pin that holds the broom flange to the motor shaft.
4. Disassemble the flange from the broom by removing the screws that hold the flange to the broom.
5. Assemble the flange to the replacement broom and fasten using the hardware removed.
6. Install the replacement broom on the shaft and insert the lock pin.

## SERVICE INSTRUCTIONS (Cont.)

### HOPPER SERVICE



Figure 29

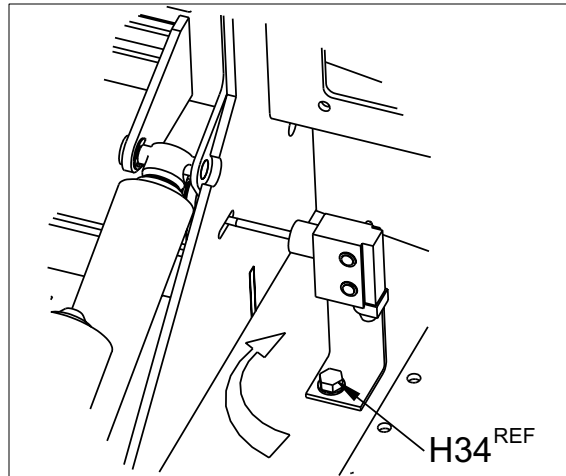

Figure 30

#### HOPPER

The hopper houses the debris compartment, the dust control filter and the removable dust baffle. For maximum performance and service life, keep the hopper clean and inspect the seals and flaps daily. Clean the hopper prior to parking the sweeper at the end of the day. A clean hopper will make inspecting the flaps and seals much easier and will prevent premature deterioration of hopper components. Do not leave the hopper full of debris while in storage or when parked for extended periods of time.

#### CLEANING THE HOPPER

Once the hopper has been emptied the insides of the hopper should be rinsed out with water.

#### ADJUSTING THE HOPPER SWITCH

With hopper fully closed and seated and bolt loose, rotate the bracket clockwise until the switch clicks. Retighten bolt. (See Figure 30).

#### DUST CONTROL FILTER

The dust control filter should be checked daily for damage and cleaned if necessary. A damaged filter must be replaced to prevent damage to other dust control system components. Inspect the filter for tears in the filter media or excessive dirt lodged in the pleats. A tear in the filter media will allow dirt to pass through the filter and can be easily seen as a dirty patch on the top side on the filter. Cleaning of the filter is necessary when the filter shaker fails to adequately clean the pleats.

#### CHECKING THE DUST CONTROL FILTER

1. Park the machine on a smooth level surface, turn the key switch to the "O" position and engage the parking brake.
2. Raise the hopper lid for access to the filter compartment.
3. Turn the filter latch, lift the filter frame and remove the filter.
4. Inspect the panel filter for tears and clean or replace if necessary.
5. Reinstall the filter, lower the filter frame and engage the filter latch.
6. Close the hopper cover.

#### CLEANING THE DUST CONTROL FILTER

Clean the dust control filter when the shaker fails to adequately clear the filter. The filter can be cleaned with compressed air not to exceed 100 PSI.

To clean the filter with compressed air, apply the compressed air to the top side of the panel to back flush the lodged dirt from the filter pleats. Be careful to not damage the filter media while cleaning. The filter can be cleaned with a solution of soap and water. If this cleaning method is used do not use the filter until it has completely dried.

**HOPPER SERVICE - Cont.**

Figure 31

**REPLACING THE DUST CONTROL FILTER**

Change the filter panel when damage is evident.

1. Park the machine on a smooth level surface, turn the key switch to the "O" position and engage the parking brake.
2. Open the hopper compartment cover to gain access to the filter compartment.
3. Turn the latch on the hinged frame counterclockwise and lift the frame .
4. Remove the filter panel.
5. Install replacement filter, lower the hinged frame and engage the latch.
6. Lower the filter compartment cover.

**DUST FLAPS**

The dust flaps are very important to sweeping and dust control and are susceptible to damage and should be inspected daily and maintained in good condition.

**CHECKING THE DUST FLAPS**

The dust flaps are used on the wheel well, broom chamber and broom door. Inspect the flaps daily and replace any flap that shows signs of wear or deterioration. All flaps should be replaced when worn or damaged to the point that they can no longer perform their normal function. The adjustable flaps have slotted mounting holes to facilitate adjustment.

**ADJUSTING THE DUST FLAPS**

Adjust the flaps so there is a 1/8" to 1/16" gap between the floor and the bottom edge of the flaps. The rear flap adjustment is 1/16" (16 cm.) above the floor.

1. Park the machine on a smooth level surface and engage the parking brake.
2. Loosen the flap retaining screws and adjust the flap to clear the floor and leave a 1/16" to 1/8" gap.
3. Tighten flap retaining screws while holding flap in position.
4. Drive the machine on a smooth surface and recheck the flaps for proper floor clearance.

## SERVICE INSTRUCTIONS (Cont.)

---

### PARKING BRAKE SERVICE

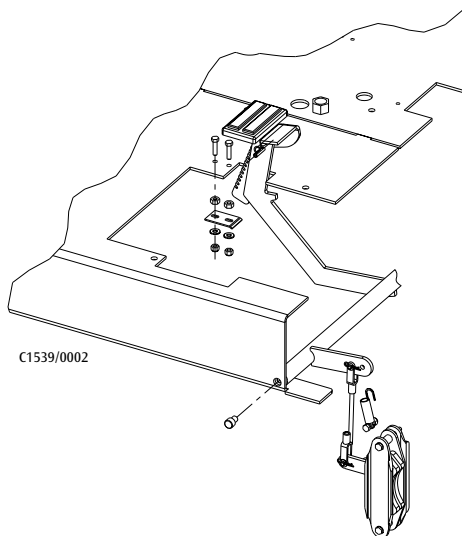

Figure 32

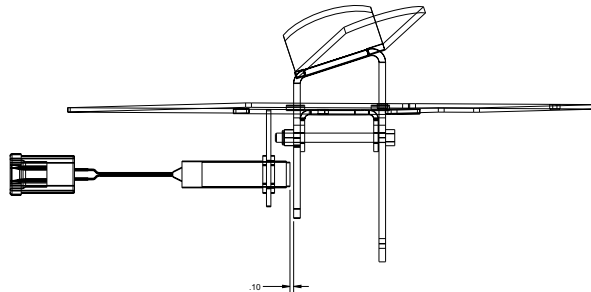

Figure 33

### PARKING BRAKES

The parking brakes are located on the front wheels. They are operated by the brake pedal and the lock lever. Check the parking brakes daily for proper operation and inspect the brake pads for wear every 100 hours of operation.

### ADJUSTING THE BRAKE PEDAL

Perform this adjustment to ensure proper pedal height and linkage operation. The brakes are properly adjusted when the brakes hold the sweeper on an 8 degree ramp. The brakes need adjusted if the Pedal travels closer than 1 inch to the floor of the operator's compartment when the brakes are fully engaged.



#### WARNING

The hopper could fall and cause serious injury. Always engage the hopper safety arm before working under the hopper.



#### WARNING

Always park on a level surface, chock tires and observe safety procedures when adjusting the brakes.

### ADJUSTING THE PARKING BRAKES

When adjusting the brake clevis, follow these steps.

1. Open cover.
2. Roll out battery on service cart
3. Remove Pin from clevis (U-Joint)
4. Adjust clevis clockwise to tighten brakes for maximum engagement.
5. With parking brake "off" rotate wheel with minimum drag (not completely free)

### ADJUSTING THE FOOT THROTTLE SWITCH

With the forward/reverse pedal in the neutral position, the switches can be adjusted to .100" of face on the forward/reverse pedal.

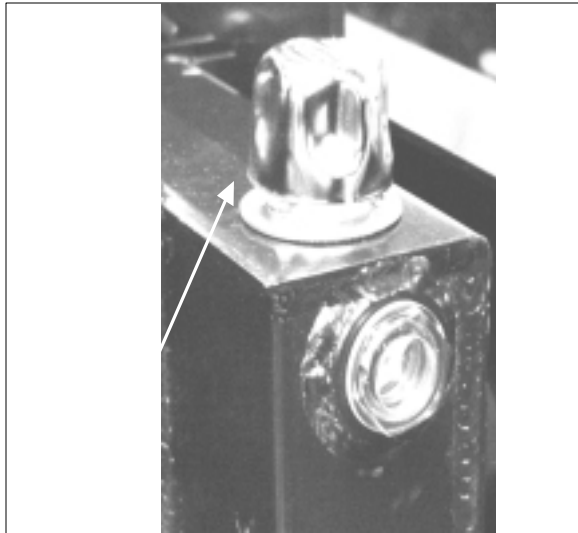

Figure 34

### FILLING THE HYDRAULIC RESERVOIR (Figure 29)

1. Access to the hydraulic reservoir is located in the engine compartment.
2. Open the hydraulic reservoir breather filter cap.
3. Remove any debris that is in the breather filter cap screen.
4. Fill the reservoir until the fluid is at the "FULL" line on the hydraulic fluid sight gauge. The sight gauge is located on the center side of the hydraulic reservoir.
5. Close the hydraulic reservoir breather filter cap.
6. Close the engine compartment cover.

### CLEANING THE HYDRAULIC SYSTEM

1. Put a drop cloth on the floor.
2. Drive the machine onto the drop cloth.
3. Set the parking brake.
4. Open the engine covers.
5. Put a container under the reservoir drain to catch the reservoir fluid. Pivot the reservoir out.
6. Remove the drain plug. The reservoir fluid will drain. Do not use the drained fluid to refill the hydraulic reservoir. Dispose of the used fluid.
7. Flush the interior of the hydraulic reservoir with clean fluid.
8. Put the reservoir plug, removed in step six, back in the hydraulic tank drain and tighten it. A pipe thread sealer is required on the plug.
9. Open the breather filter cap.
10. Fill the reservoir with new SAE 30W non detergent automotive transmission fluid. The capacity of the tank is 4.7 gal (17.79 liters). Fill to the "FULL" line on the hydraulic fluid sight gauge.
11. Close the breather filter cap. Rotate the reservoir into the engine compartment.
12. Replace the engine covers.



Figure 35

### REPLACING THE RETURN FILTER ELEMENT

1. Replace the return filter element after 250 hours of machine run time.
2. Unscrew the fasteners from the filter assembly cover and retain.
3. Remove the cover and the compression spring and retain.
4. Discard the old filter element.
5. Position the new filter element inside the filter body.
6. Put the compression spring in position. Wipe the cover magnet free of any metal filings or debris.
7. Place O-ring (moisten with clean hydraulic fluid) and cover into position.
8. Reattach fasteners to the filter cover.
9. Clean any hydraulic reservoir fluid spills. The fluid can damage painted surfaces of the machine.

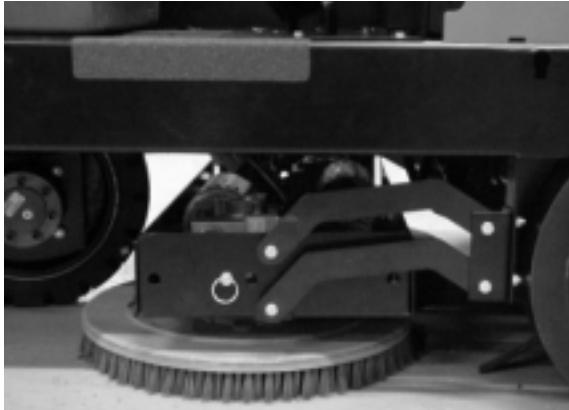

Figure 36

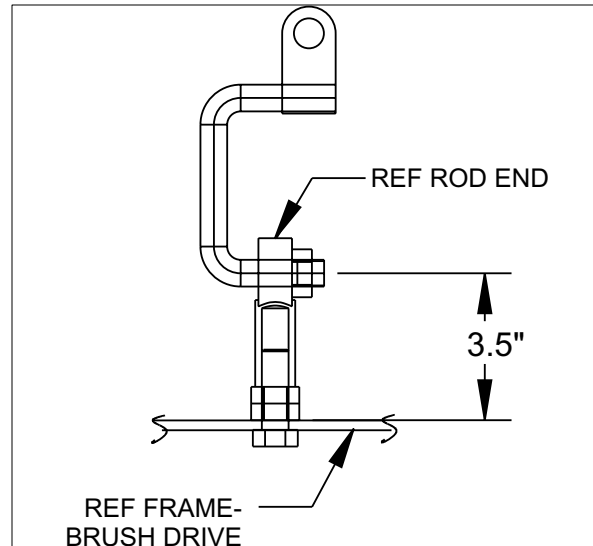

Figure 37

### REPLACING THE SCRUB BRUSH

1. Raise the scrub brush deck by pressing the “Scrub Brush” switch on the instrument panel.
2. Press the brush latches in to release the scrub brush.
3. Remove the old scrub brush.
4. Snap the new brush into place.

### ADJUSTING THE SCRUB DECK (See Figure 37)

Adjust the center of the rod end to 3.5” from the frame.

### COVERS AND LATCHES

The covers have been designed to allow access, either by hinge or removal, to all areas of the machine. No maintenance is required.

### SOLUTION LOW WARNING LIGHT

The solution low warning light will illuminate when the solution tank is low. This part of the level control system requires no maintenance. If the system fails to operate, consult the Electrical Troubleshooting Guide.

### RECOVERY HIGH WARNING LIGHT

The recovery high warning will illuminate approximately 5 minutes before loss of vacuum to the recovery tank. This part of the level control system requires no maintenance, except for daily cleaning of the tank level switch. If the system fails to operate, consult the Electrical Troubleshooting Guide.

### SOLUTION CONTROL (Non-Recycling or Standard)

The solution control knob controls the amount of solution applied to the scrubbing brushes.

The solution control should shut off completely with the knob in the “off” position. If complete shut off does not occur, the control valve should be adjusted.

### SOLUTION CONTROL (Recycling or ESP System)

In the recycling mode, the solution control lever is also used to activate the detergent pump. If the detergent pump fails to operate (engine running) when the solution control lever is moved into the low to high range, first check the circuit by manually activating the switch. If the detergent pump does not operate at this time, a further electrical or mechanical check is required (see Electrical Troubleshooting Guide or Detergent Pump Troubleshooting).

### RECYCLING PUMP ESP SYSTEM

The recycling pump is located under the seat. The pump is electric and except for daily cleaning of the pump intake screens, it requires no regular maintenance.

### RECYCLING PUMP STORAGE

Always drain pump for extended storage, especially when freezing temperatures may be encountered.

### REAR SQUEEGEE

The squeegee will require service when the inner edges of the blades become round with wear, impairing the wiping action or water pickup. To service the rear squeegee use the following steps:

1. Loosen the four aluminum knobs
2. Remove the squeegee tool and turn upside down to service the blades or caster wheels. The squeegee blades are designed to flip over and use another unworn edge.

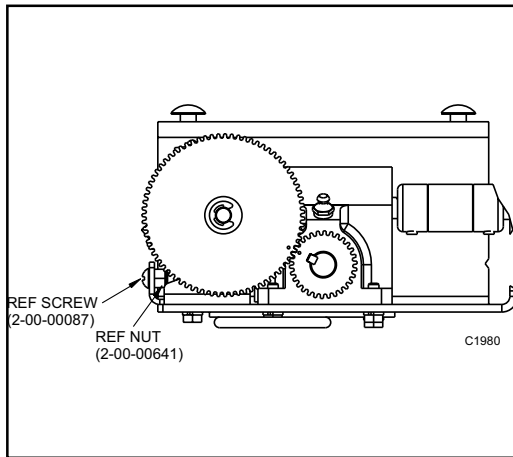

Figure 38

### ADJUSTING THE REAR SQUEEGEE LIFT

1. Loosen nut (2-00-00641).
2. Turn screw (2-00-00087) either counterclockwise (to raise) or clockwise (to lower) to adjust the position of the squeegee lift. (The gap between the frame and the squeegee lift should be .75").

### NOTE

Raising squeegee lift too far will cause the squeegee lift to hit the frame and may cause damage.

### To service the blades

1. Loosen the clamp bolts which clamp items 8 & 9 together.
2. Loosen far enough to slip the end clamp brackets off the squeegee tool. This will allow flipping the blades or installing new blades.
3. Install blades so that the outer blade is 3/16" longer than the inner blades. This is achieved by assembling the top edge of the blade against the squeegee tool weldment.
4. Reinstall the squeegee clamp band and tighten the clamp bolt.

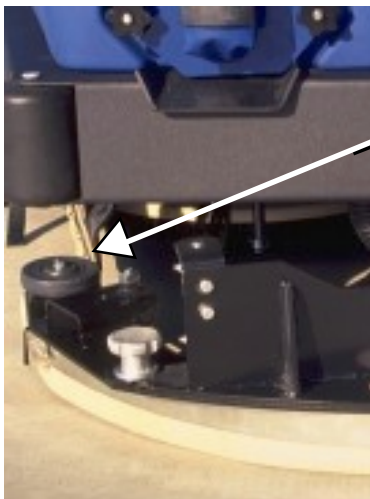

Figure 39

### SQUEEGEE CASTER WHEELS

There are 2 grease fittings on each caster wheel. The casters should be greased each time the blades are serviced.

### ADJUSTING CASTERS

Lower the squeegee on a flat surface, making sure the rear squeegee blade is perpendicular to the surface. Adjust the caster 3/16" above the flat surface. Lock the jam nuts.

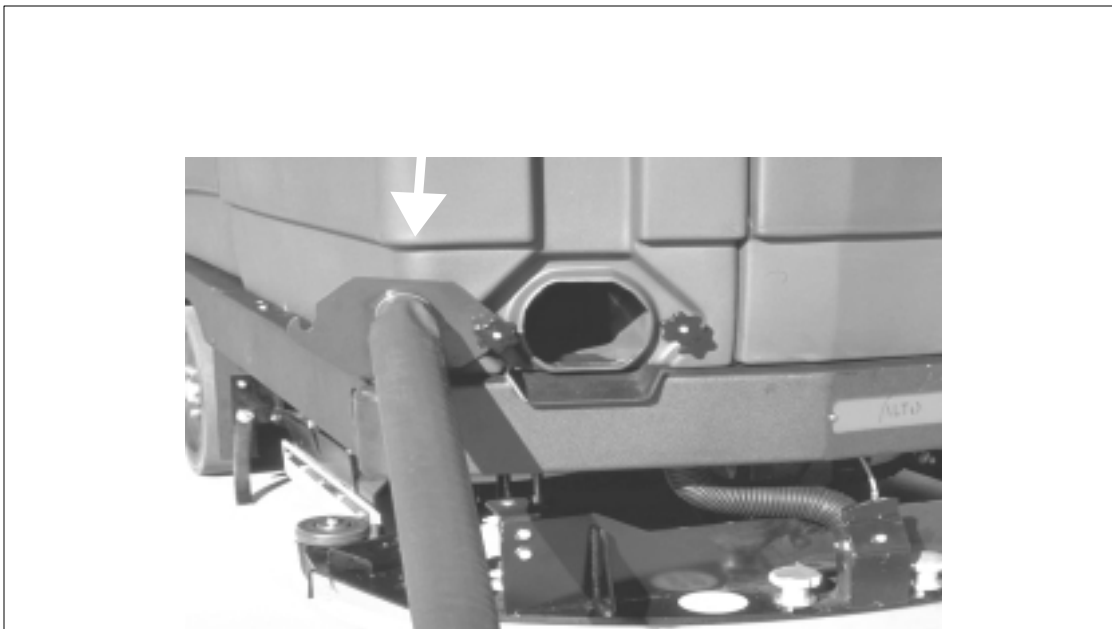

Figure 40

### **EMPTYING THE RECOVERY TANK (Figure 36)**

Simply lower the drain hose, telescope out to a drain and let the recovery tank drain. The farther you telescope the hose the faster the water will drain.

When finished draining recovery tank loosen both knobs on the recovery clean out door. The door will pivot on the left knob, allowing room to let any debris to be sprayed out of the recovery tank with a water hose or pressure washer.

**ABBREVIATIONS - SCREWS**

ADJ	= Adjusting Screw
ADJ.SP	= Adjusting Plunger Screw
BHM	= Binding Head Machine Screw
BHS	= Button Head Socket Screw
CAPT.SL	= Captivated Slotted Screw
CAPT.WG	= Captivated Wing Screw
FHM	= Flat Head Machine Screw
FIL.HM	= Filister Head Machine Screw
HHC	= Hexagon Head Cap Screw
HHM	= Hexagon Head Machine Screw
HIHD	= 1/2 High Head Screw
HSHC	= Hexagonal Socket Head Cap Screw
HSFHC	= Hexagonal Socket Flat Head Cap Screw
KNH	= Knurled Head Screw
MHHC	= Metric Hexagon Head Cap Screw
PHM	= Pan Head Machine Screw
RHD	= Round Head Drive Screw
RHM	= Round Head Machine Screw
RHW	= Round Head Wood Screw
SHC	= Shiny Crown Cap Screw
SHTB	= Shoulder Thumb Screw
SQ	= Square Head Screw
TB	= Thumb Screw
THM	= Truss Head Machine Screw
WELD	= Weld Stud
WG	= Wing Screw

**ABBREVIATIONS - SETSCREWS**

HS	= Hexagonal Socket Setscrew
S	= Slotted Setscrew
SH	= Square Head Setscrew
-KCP	= Knurled Cup Point Setscrew
-CP	= Cup Point Setscrew
-OP	= Oval Point Setscrew
-FDP	= Full Dog Point Setscrew
-HDP	= Half Dog Point Setscrew
-FP	= Flat Point Setscrew
-COP	= Cone Point Setscrew

## HARDWARE LEGEND

Key No.	Part Number	Description
H1	2-00-05060	Screw, #6-32 x 1.250 RHM
H2	2-00-00455	Flat Washer, .375 x .156 x .047
H3	2-00-01499	Lock Washer, #6 Med. Helical Spring
H4	2-00-00624	Nut, #6-32 Hex
H5	2-00-00645	Nut, Hex Fiber Insert #6-32
H6	2-00-00049	Screw, # 10-24 x .500 RHM
H7	2-00-00056	Screw, # 10-24 x .750 RHM
H8	2-00-00039	Screw, 10-24 x 1.000 RHM
H9	2-00-00426	Flat Washer, .500 x .219 x .063
H10	2-00-00519	Lock Washer, # 10 Med HS
H11	2-00-00605	Nut, Hex MS # 10-24 x .375 x .125
H12	2-00-01246	Nut, Hex Fiber Insert #10-24
H13	2-00-00054	Screw, 1/4-20 x .500 RHM
H14	2-00-00219	Screw, 1/4-20 x .500 HHC
H15	2-00-00221	Screw, 1/4-20 x .750 HHC
H16	2-00-03051	Screw, 1/4-20 x .750 HSHC
H17	2-00-00205	Screw, 1/4-20 x 1.000 HHC
H18	2-00-00060	Screw, 1/4-20 x 1.250 RHM
H19	2-00-02587	Screw, 1/4-20 x 1.250 HHC
H20	2-00-00203	Screw, 1/4-20 x 1.500 HHC
H21	2-00-01769	Screw, 1/4-20 x 1.750 HHC
H22	2-00-02589	Screw, 1/4-20 x 2.000 HHC
H23	2-00-01980	Screw, 1/4-20 x 2.500 HHC
H24	2-00-00220	Screw, 1/4-20 x .625 HHC
H25	2-00-00594	Nut, Hex 1/4-20 x .437 x .218
H26	2-00-00641	Nut, 1/4-20 Insert Fiber
H27	2-00-03702	Washer, .625 x .281 x .063
H28	2-00-04685	Screw, 1/4-20 x .750 HHC
H29	2-00-04966	Screw, 1/4-20 x 1.500 HHM
H30	2-00-04687	Lock Washer, Helical Spring 1/4 Med.
H31	2-00-04695	Screw, # 10-32 x .630 RHM
H32	2-00-04688	Nut, 1/4-20 Hex.
H33	2-00-00224	Screw, 5/16-18 x .500 HHC
H34	2-00-00208	Screw, 5/16-18 x .750 HHC
H35	2-00-02708	Screw, 5/16-18 x 1.000 HHM
H36	2-00-00196	Carriage Bolt, 5/16-18 x 1.000
H37	2-00-00207	Screw, 5/16-18 x 1.250 HHC
H38	2-00-00225	Screw, 5/16-18 x 1.500 HHC
H39	2-00-00218	Screw, 5/16-18 x 2.000 HHC
H40	2-00-01770	Screw, 5/16-18 x 2.750 HHC
H41	2-00-02597	Screw, 5/16-18 x 3.250 HHC
H42	2-00-02655	Screw, 5/16-18 x 4.500 HHC
H43	2-00-00409	Flat Washer, .687 x .344 x .062
H44	2-00-00530	Lock Washer, 5/16 HS Med.
H45	2-00-00585	Nut, Hex. 5/16-18 x .500 x .265
H46	2-00-00644	Nut, 5/16-18, Insert Fiber
H47	2-00-00232	Screw, 3/8-16 x .750 HHC
H48	2-00-00233	Screw, 3/8-16 x 1.000 HHC
H49	2-00-00209	Screw, 3/8-16 x 1.250 HHC
H50	2-00-00234	Screw, 3/8-16 x 1.500 HHC
H51	2-00-00216	Screw, 3/8-16 x 2.000 HHC
H52	2-00-00402	Flat Washer, .750 x .390 x .094
H53	2-00-02310	Lock Washer, Helical Spring 3/8 Med.
H54	2-00-02360	Nut, 3/8-16 Hex.
H55	2-00-00643	Nut, 3/8-16 Stop
H56	2-00-00239	Screw, 1/2-13 x 1.000 HHC
H57	2-00-00240	Screw, 1/2-13 x 1.250 HHC
H58	2-00-00241	Screw, 1/2-13 x 1.750 HHC
H59	2-00-00242	Screw, 1/2-13 x 2.250 HHC

## HARDWARE LEGEND

Key No.	Part Number	Description
H60	2-00-02682	Screw, 1/2-13 x 2.750 HHC
H61	2-00-02616	Screw, 1/2-13 x 3.000 HHC
H62	2-00-00405	Flat Washer, 1.063 x .531 x .094
H63	2-00-02312	Lock Washer, 1/2 HS Med.
H64	2-00-00596	Nut, Hex. 1/2-13 x .750 x .437
H65	2-00-04936	Nut, 1/2-13 Fiber Lock
H66	2-00-02689	Screw, 1/2-20 x 1.000 HHC
H67	2-00-00614	Nut, Hex 1/2-20
H68	2-00-00640	Nut, Hex Fiber Insert 1/2-20
H69	2-00-01255	Screw, 5/16-18 x .875 HHC
H70	2-00-05254	Screw, 3/4-10 x 2.250 HHC
H71	2-00-05255	Nut, 3/4-10 Nylon Lock
H72	2-00-00518	Lock Washer, Helical Spring
H73	2-00-00247	Screw, 1/2-13 x 2.500 HHC
H74	2-00-03170	Flat Washer, 1.500 x .750 x .125
H75	2-00-00618	Nut, Hex Jam 3/8-16
H76	2-00-00632	Nut, Fiber Insert 3/8-24 Steel
H77	2-00-00484	Flat Washer, .625 x .375 x .046
H78	2-00-05187	Carriage Bolt, 3/8-16 x 1.250
H79	2-00-01676	Flat Washer, 1.062 x .265 x .062'
H80	2-00-02196	Carriage Bolt, 1/4-20 x 1.000 RHM
H81	2-00-05276	Screw, 3/8-16 x 5.500
H82	2-00-00505	Lock Washer, 3/8 Int. Tooth
H83	2-00-04877	Screw, 1/4-20 x 1.000 BHS
H84	2-00-00228	Screw, 5/16-18 x 2.250 HHC
H85	2-00-00650	Nut, Cap 3/8-16 Low Crown
H86	2-00-03575	Carriage Bolt, 1/4-20 x .750
H87	2-00-00263	Set Screw, 1/4-20 x .250 HSKCP
H88	2-00-05258	Screw, #8-325 x .750 BHS
H89	2-00-01372	Nut, Fiber Insert #8-32 Steel
H90	2-00-03569	Carriage Bolt, 5/16-18 x .750
H91	2-00-05279	Screw, M6 x 1.0 x 20 mm MHHC
H92	2-00-04801	Flat Washer, .875 x .375 x .125
H93	2-00-00222	Screw, 1/4-20 x 1.250 HHM
H94	2-00-00410	Flat Washer, .875 x .375 x .060
H95	2-00-03382	Spring Washer, .875 x .500 x .015
H96	2-00-02605	Screw, 3/8-16 x 4.500 HHC, Cadium Plated
H97	2-00-04677	Screw, 1/4-20 x .750 HSC
H98	2-00-05277	Screw, 1/2-13 x .750 HSHC
H99	2-00-02810	Screw, 1/4-20 x 1.000 FHM
H100	2-00-03062	Screw, #10-24 x .625 THM
H101	2-00-04897	Screw, #10-24 x 1.250 THM
H102	2-00-04795	Screw, #10-24 x .750 BHS
H103	2-00-00089	Screw, 10-24 x 1.500 RHM
H104	2-00-03541	Screw, 1/4-20 x 1.500 FHSC
H105	2-00-05260	Nut, Jam #8-32
H106	2-00-04886	Screw, 3/8-16 x .500 HSHC
H107	2-00-04887	Screw, Main Broom Control
H108	2-00-04888	Washer, Main Broom Control
H109	2-00-00522	Lock Washer, 3/4 Helical Spring
H110	2-00-03039	Screw, 1/4-20 x .625 HSHC
H111	2-00-03296	Screw, 3/8-16 x 4.000 HHC
H112	2-00-02603	Screw, 3/8-16 x 3.500 HHC
H113	2-00-03333	Screw, 3/8-16 x 3.750 HHC
H114	2-00-00633	Nut, Fiber 1/4-28
H115	2-00-03063	Screw, #10-24 x .750 THM
H116	2-00-01951	Carriage Bolt, 1/4-20 x 1.250
H117	2-00-05067	Flat Washer, 1.750 x .531 x .100
H118	2-00-02618	Screw, 1/2-13 x 3.500 HHC
H119	2-00-05005	Screw, M10 x 1.500 30 mm MHHC

## HARDWARE LEGEND

---

<i>Key No.</i>	<i>Part Number</i>	<i>Description</i>
H120	2-00-03829	Lock Washer, 3/8 Bolt
H121	2-00-00090	Screw, #8-32 x 1.500 RHM
H122	2-00-05216	Screw, 1/4-20 x 5.000 HHC
H123	2-00-00204	Screw, 1/4-20 x 1.500 HHC
H124	2-00-02296	Lock Washer, #10 Ext. Shakeproof
H125	2-00-00418	Flat Washer, .984 x .627 x .063
H126	2-00-03466	Screw, #10-16 x .500
H127	2-00-03522	Washer, 5/16 x 1.250 x .050
H128	2-00-04681	Carriage Bolt, 5/16-18 x 1.250
H129	2-00-02311	Lock Washer, 4.38 Split
H130	2-00-03334	Screw, .44-20 x 1.000 HHC
H131	2-00-03855	Carriage Bolt, 3/8-16 x 1.000
H132	2-00-00503	Lock Washer, 1/4 Ext.
H133	2-00-00006	Screw, #10-24 x .675 FHM
H134	2-00-03032	Screw, 3/8-16 x .750 FHS
H135	2-00-05298	Flat Washer, .344 x 2.000 x .062
H136	2-00-03940	Screw, #10-24 x .500 T/C HH
H137	2-00-05299	Screw, #10-24 x 1.250 HSHC
H138	2-00-00504	Lock Washer, Int.
H139	2-00-00611	Nut, Hex Jam, 3/8-24
H140	2-00-00447	Flat Washer, 1.250 x .280 x .090
H141	2-00-00501	Lock Washer, Int.
H142	2-00-05244	Carriage Bolt, 1/2-13 x 2.000
H143	2-00-00432	Flat Washer, 1.13 x .770 x .063
H144	2-00-02303	Lock Washer, Int.
H145	2-00-04180	Setscrew, 1/4-20 x .500
H146	2-00-00420	Flat Washer, 1.000 x .516 x .063
H147	2-00-00642	Nut, Fiber Insert 5/18-18
H148	2-00-01778	Screw, 1/2-13 x 2.000 HHC
H149	2-00-01803	Washer, 1.063 x .031 x .063
H150	2-00-00211	Screw, 5/16-18 x 1.750 HHC
H151	2-00-00213	Screw, 5/16-18 x .625 HHC
H152	2-00-01562	Carriage Bolt, 5/16-18 x 2.250
H153	2-00-03266	Washer
H154	2-00-04363	Screw, M8-1.250 x .750
H155	2-00-05044	Lock Washer, M14 Split
H156	2-00-05079	Screw, M14 x 1.500 x 25 mm HHC
H157	2-00-00217	Screw, 5/16-18 x 2.000 HHC
H158	2-00-05306	Screw, M14 x 35 mm HHC
H159	2-00-00512	Lock Washer
H160	2-00-00441	Flat Washer, .438 x .200 x .036
H161	2-00-00153	Screw, #8-24 x .875 OHM
H162	2-00-03961	Screw, 5/16-24 x 1.000 HHC
H163	2-00-03570	Carriage Bolt, 3/8-16 x .750
H164	2-00-00107	Screw, 10-24 x 4.50 RD. HD.
H165	2-00-00589	Nut, Hex Jam, .25-20
H166	2-00-00066	Screw, 6-32 x .50 RHM
H167	2-00-04312	Screw, 10-24 x .625 T/C Hex HD.
H168	2-00-05261	Insert, 1/4-20
H169	2-00-02637	Screw, 1/4-20 x 2.750 HHC
H170	2-00-03061	Screw, # 10-24 x .500 THM
H171	2-00-02371	Nut, Hex Jam .50-13 STL.
H172	2-00-04986	Screw, 1/4-20 x 4.500
H173	2-00-02709	Screw, 5/16-18 x 1.500
H174	2-00-00183	Screw, 1/4-20 x .750 THM
H175	2-00-01252	Screw, 10-24 x 2.750 RDH
H176	2-00-05337	Screw, #8-32 x .750 BHS SS
H177	2-00-05324	Threaded Insert, #8-32
H178	2-00-00206	Screw, 5/16-18 x 1.000 HHC

## HARDWARE LEGEND

<i>Key No.</i>	<i>Part Number</i>	<i>Description</i>
H179	2-00-04948	Screw, 25mm - M8 x 1.250
H180	2-00-04378	Clip, Water Line
H181	2-00-05078	Screw, M6 x 1.000 x 10mm HHC
H182	2-00-00236	Screw, 5/8-16 x 2.500 HHC
H183	2-00-05042	Lock Washer, M10
H184	2-00-04366	Screw, M10 x 1.500 x 25mm
H185	2-00-02588	Screw 1/4-20 x 1.125 HHC Cad. Pl.
H186	2-00-03041	Screw, 1/4 x 1.250 HSC-SS
H187	2-00-00071	Screw, #10-24 x 1.250 RHM
H188	2-00-01987	Flat Washer, .438 x .200 x .036 sst
H189	2-00-00460	Flat Washer, .437 x .192 x .031-s
H190	2-00-00529	Lock Washer - helical sps, 8 MDM
H191	2-00-00602	Nut, MSCR - Hex, 8-32
H192	2-00-04841	Nut 3/4 - 16 Slotted Hex head
H193	2-00-03412	Lock Nut, .375 - 24, sps 21 FK
H194	2-00-03537	Screw - 1/4 - 20 x2.000
H195	2-00-04210	Clamp
H196	2-00-05350	Screw 1/4 - 28 x .63 HHC
H197	2-00-03979	Washer 1.00 x .391 x .06
H198	2-00-03808	Washer 1.50 x .750 x .06
H199	2-00-04603	Clamp
H200	2-00-00626	Nut, Hex MS #10 - 32 x .375 x .125
H201	2-00-02011	Plastic Plug, .440 Dia (Diesel)
H202	2-00-04514	Plastic Plug, .562 Dia ( LP & Gas)
H203	2-00-04794	Screw, #10 - 24 x .625 BHS
H204	2-00-04873	Clamp
H205	2-00-04721	Grommet, 1.750 x 1.125 x .500 x .125
H206	2-00-00407	Washer, Flat .562 x.265
H207	2-00-02227	Key, .125 x .750 SQ
H208	2-00-00772	Cotterpin .093 x 1.000
H209	2-00-00586	Nut Hex Jam 5/16 - 18x .500 x .187
H210	2-00-00776	Cotterpin .125x1.500
H211	2-00-02728	Screw 10 - 32 x .375 BHM
H212	2-00-00566	Fitting-Grease
H213	2-00-01254	Screw - 1/2 - 13 x 1.500 HHCS
H214	2-00-00462	Flat Washer, .562 x .250 x .031
H215	2-00-02558	Grease Zerk
H216	2-00-04378	Harness Clamp
H217	2-00-00511	Internal Washer, #6
H218	2-00-05345	Screw, Hex Head Cap
H219	2-00-05359	Nut, Serrated Flange 5/16-18
H220	2-00-02617	Screw, 50-13 x 3.25 HHC
H221	2-00-03335	Screw, Hex SOC Cap, .312 - 18 x .50
H222	2-00-02848	Screw, 10-32 x .50 Cad PL, STL RHM
H223	2-00-00631	Nut, .31 - 24 Fiber Insert
H224	2-00-04686	Lock Washer - helical #10 Scr. Med. SST
H225	2-00-04851	Washer, Engine Mount
H226	2-00-04689	Washer, 11/16 OD x .260 ID x .050
H227	2-00-04596	Screw, Hex Head 1/4 - 20 x 3.5
H228	2-00-02606	Screw, .375 - 24 x 1.00 Cad. PL, STL HHC
H229	2-00-01490	Screw, .25 - 20 x .875 HHC STL
H230	2-00-00466	Flat Washer, .625 x .203 x .031
H231	2-00-02933	Screw, Mach 10 - 24 x 3.50
H232	2-00-04909	Yoke, Pin Assy.
H233	2-00-02638	Screw, HHC .25-20 x 3.00
H234	2-00-00064	Screw- RHM #10-24 x .88
H235	2-00-00197	Carriage Bolt, .38-16 x 2.75
H236	2-00-02369	Nut, Hex Jam, .38-16
H237	2-00-05356	Screw, 5/16 - 18 X 1.25 Grade 8

## HARDWARE LEGEND

Key No.	Part Number	Description
H238	2-00-03750	Carriage Bolt, .38-16 x 1.50
H239	2-00-02814	Screw-FHM .25-20x1.75
H240	2-00-05398	Screw, HSHC 3/8-16 x .50
H241	2-00-05395	Screw, RHM .25-20 x 4.00 Zinc
H242	2-00-05370	Screw, M12 - 16 x 1.75 x 40mm HHC
H243	2-00-00591	Nut, Hex-Jam .50-20
H244	2-00-05297	Nut, Insert Fiber, .38-16 Heavy Nut
H245	2-00-05401	Shoulder Screw, 1/2-3/4
H246	2-00-05122	Screw-HHC, .25-20 x 2.00
H247	2-00-04590	Washer
H248	2-00-05236	Flat Washer, 2.000 x .281 x .063
H249	2-00-00004	Screw, FHM #10-24 x 1.25
H250	2-00-04968	Screw, T/FRH #14-10 x 1.00 Type A
H251	2-00-02602	Screw 3/8-16 x 2.750 HHC Cad. Pl
H252	2-00-00600	Nut, Hex Heavy 3/8-16
H253	2-00-05120	Nut, .75-Hex Nyloc Jam
H254	2-00-04625	Screw-HHM .375-24 x .75
H255	2-00-00227	Screw-HHC .313-18 x 2.25
H256	2-00-02354	Nut-Hex-Jam .50-20
H257	2-00-00093	Screw-RHM 6-32 x .75
H258	2-00-04062	Screw-T/FFH #6-20 x .50
H259	2-00-05343	Bolt Carriage, .38-16 x 3.50 sstl
H260	2-00-00615	Nut, Hex Fin .63 - 22
H261	2-00-05344	Screw - HHM .313 - 18 x 1.75 Stl
H262	2-00-00617	Nut, Hex, Finish .75-16
H263	2-00-02313	Lock Washer, Helical Spring .63 Scr. Med.
H264	2-00-02622	Screw, 5/16 - 18 x 1.000 HHM
H265	2-00-00506	Lock Washer, Int Tooth #8 Dia Screw
H266	2-00-05371	Screw-RHM #8-32 x 2.38
H267	2-00-00068	Screw-RHM #8-32 x .63
H268	2-00-00051	Screw-RH, .25 - 20 x .75
H269	2-00-00118	Screw - RHM #10 - 24 x .625
H270	2-00-05341	Screw-HHC .75-10 x 2.00
H271	2-00-03293	Nut-Hex-Fin .75-10
H272	2-00-04563	Screw, Shoulder #10-24
H273	2-00-03214	Screw, .31-18 x .75 Zinc PL HSHC
H274	2-00-02676	Screw, .50 - 13 x .75 HHM
H275	2-00-00237	Screw, HHC .375 - 16 x 3.00
H276	2-00-00223	Screw, HHC .25-20 x 1.25 nickel
H277	2-00-05164	Screw, HHM 5/16 - 18 x 3.50
H278	2-00-03044	Screw, .38 - 16 .75 HSHC
H279	2-00-04914	Screw, .50 - 13 x 4.50 HHC
H280	2-00-00187	Bolt Carriage, .38 - 16 x 2.50
H281	2-00-00415	Flat Washer, .9375 x .468 x .0625 STL
H282	2-00-02562	Fitting
H283	2-00-03842	Roll Pin, 1/4 x 1.00
H284	2-00-04845	Screw, 3/8-16 x 1.00 FHSC
H285	2-00-05153	Screw, 1/4 x 20 1.50 HHC
H286	2-00-05383	Washer, Special
H287	2-00-00264	Set Screw, 1/4-20 x .313 HSKCP
H288	2-00-00668	Wing Nut, 5/16-18
H289	2-00-00532	Snap Ring
H290	2-00-02049	Bearing - Double Seal
H291	2-00-02243	Square Key, .188 - .187 x 1.250
H292	2-00-02293	Lockwasher, 5/8 Int.
H293	2-00-03151	Spacer, 1/2 ID 3/4 .625 Lg.
H294	2-00-03158	Spacer, 1/2 ID 3/4 .3/8 Lg.
H295	2-00-03306	Bearing
H296	2-00-03413	Flat Washer, 1.125 x .765 x .062
H297	2-00-04345	Tye - Wrap

## HARDWARE LEGEND

<i>Key No.</i>	<i>Part Number</i>	<i>Description</i>
H298	2-00-04708	Terminal
H299	2-00-05183	Terminal, 1/4 x .03 12-10
H300	2-00-00767	Cotter Pin, .063 x.500
H301	2-00-04159	Flat Washer, 1.375 x .563 x .109 STL
H302	2-00-00490	Washer, Spring, Shakeproof
H303	2-00-05103	Flat Washer, .750 x .343 x .050 SS
H304	2-00-00246	Screw, .25 - 20 x 2.25 HHC
H305	2-00-00809	Screw, HSHC .31 - 18 x 1.00
H306	2-00-05405	Nut, 3/8 - 32 NEF 2A
H307	2-00-02963	Screw, RHM #10-32 1/4 PL. (Steel)
H308	2-00-05388	Sealing Washer 46/53 ESP OPT
H309	2-00-01081	Screw - T/C RH #8-32x.50type 2
H310	2-00-02393	non-existent
H311	2-00-05024	Washer Flat, 2 x 1.06
H312	2-00-05227	Screw, HHC M14 x 1.50 x 45mm gr10
H313	2-00-04652	Screw, HHC .438 - 20 x 1.50
H314	2-00-03836	Bolt Carriage, .31 - 18 x 1.75
H315	2-00-00593	Nut, .38 - 16 Hex Heavy Jam
H316	2-00-00044	Screw, RHM #8 - 32 x .50
H317	2-00-00252	Screw, .313 - 18 x 4.00 HHC
H318	2-00-04750	Screw, BTN HD SKT
H319	2-00-02352	Nut, Hex Hvy. .50-13 stl-zn
H320	2-00-05424	Screw, Shoulder 1/2 - 1/2
H321	2-00-04699	Screw, HHC, .375-16 x 2.75
H322	2-00-03993	Screw, HHM 3/4-16 x 3.000
H323	2-00-00244	Screw, HHC .25-20 x 1.000
H324	2-00-05329	Screw, HHc M10 x 1.50 x 40mm S/S
H325	2-00-00092	Screw Ph.RHM #8-32 x 1.75 Zn.

## ORDERING PARTS

---

Parts may be ordered from American-Lincoln authorized distributors. Inspect the Alto U.S. serial plate to avoid delays in filling you orders:

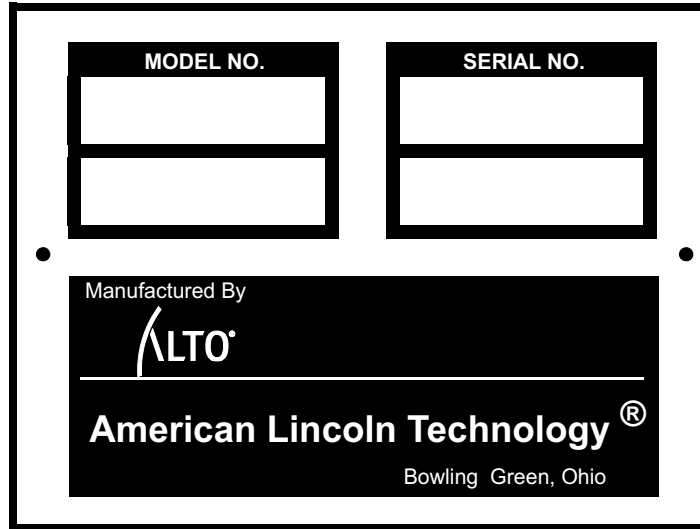

1. Use the model number, catalog number, and serial number when ordering.
2. Give the part number, description, and quantity of parts needed.
3. Give shipping instructions for either freight, UPS, or parcel post.

Parts and supplies listed in this manual can be ordered from the following address:

<b>Alto U.S., Inc. American Lincoln Technologies</b>	<b>Alto U.S., Inc. Distributor</b>
<b>1100 Haskins Road Bowling Green, Ohio 43402 (800) 331-7692</b>	

### MACHINE CATALOG NUMBER

505-310	SMART 2000 40" Sweeper/Scrubber
505-311	SMART 2000 46" Sweeper/Scrubber
505-318	SMART 2000 40" Sweeper/Scrubber w/ Dust Control
505-319	SMART 2000 46" Sweeper/Scrubber w/ Dust Control

ELECTRICAL SCHEMATIC (BATTERY)

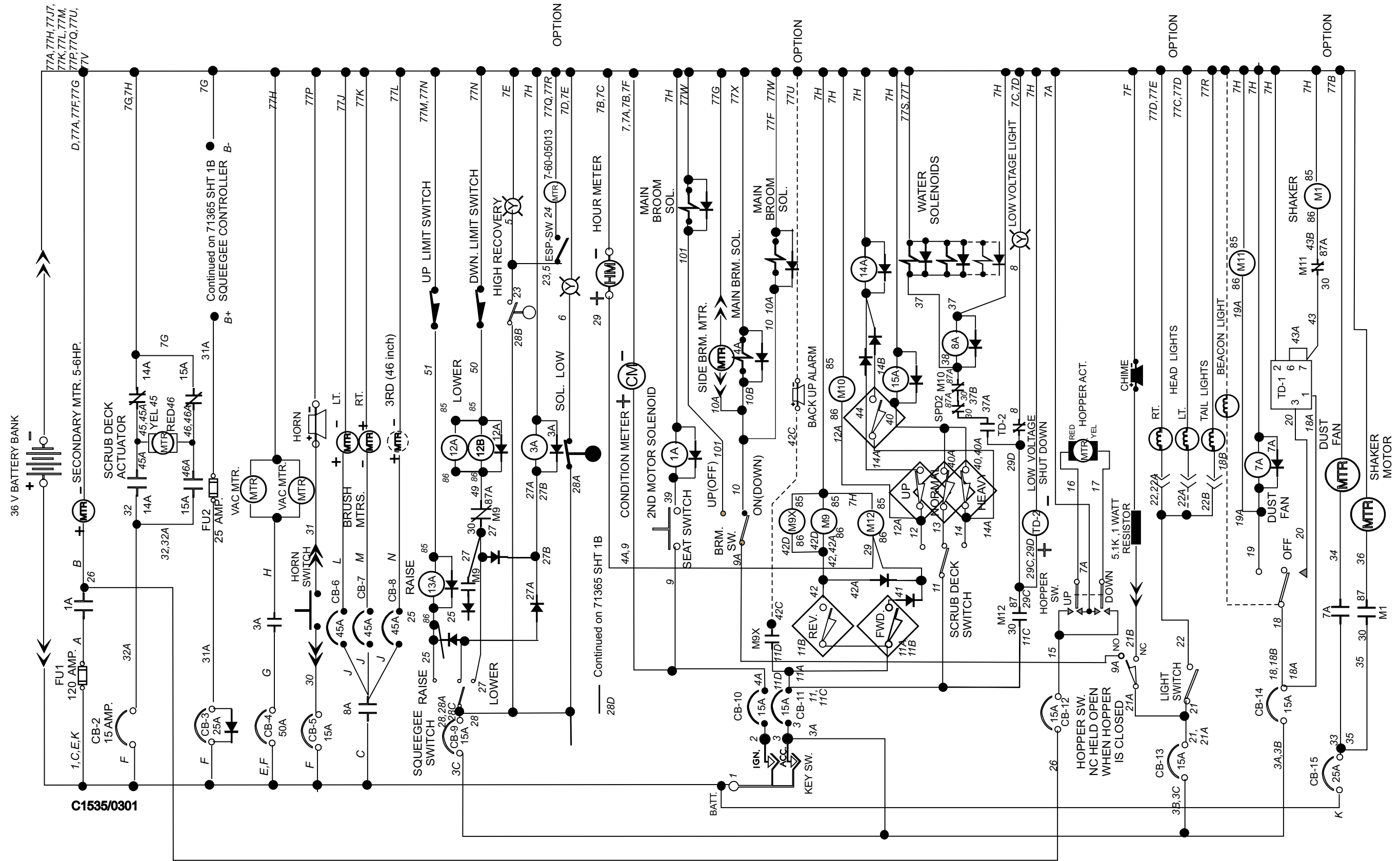

C1535A/0301

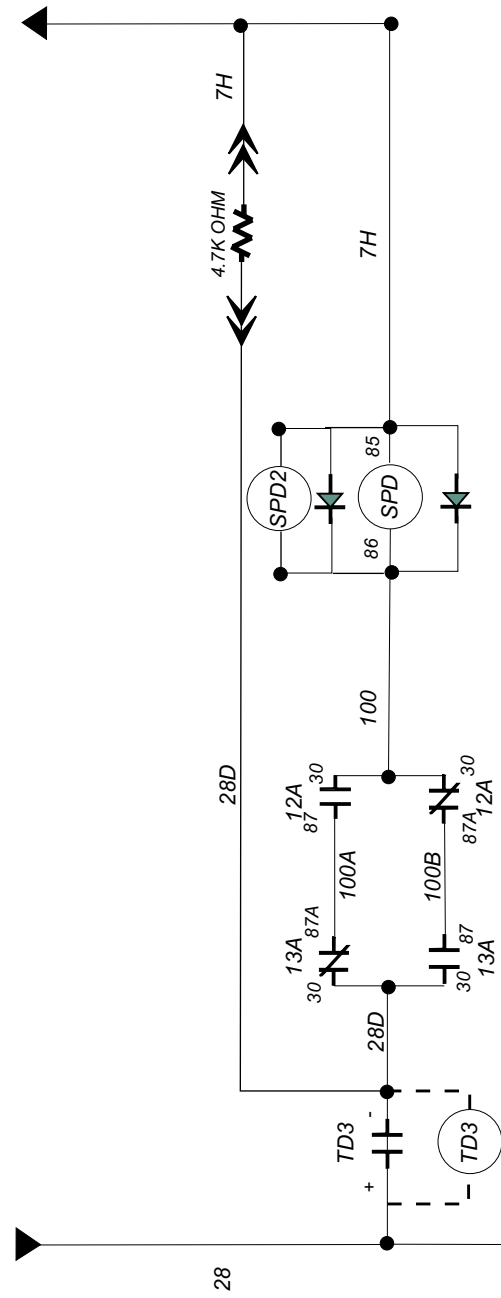

CURTIS 1303-303 CONTROLLER

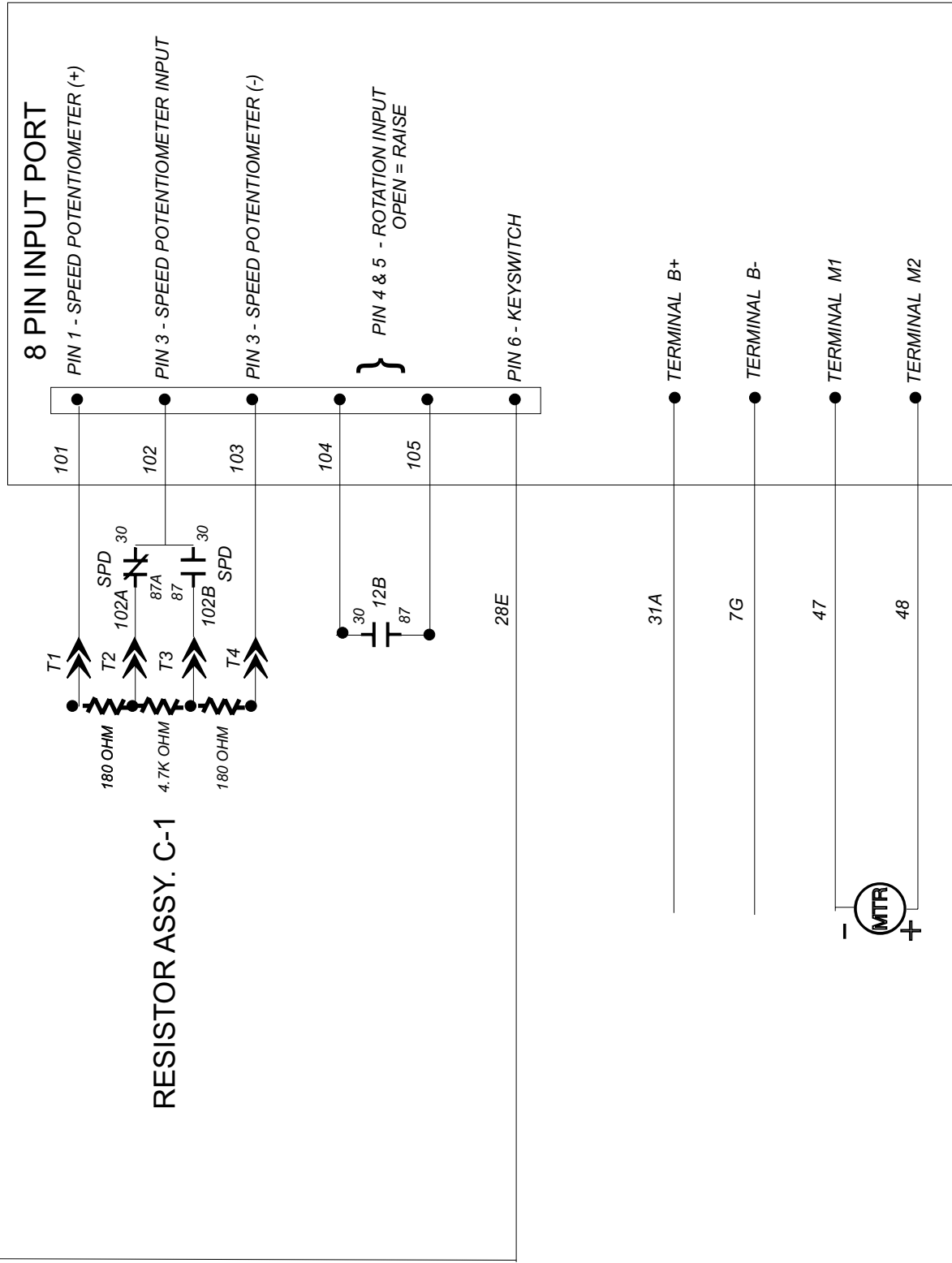

CONNECTION - HARNESS ROUTING(BATTERY)

ITEM	QTY.	PART NO.	DESCRIPTION
1	1	0795-130	HARN.-MACH.
2	12	2-00-04345	TYE-RAP
3	3	0775-188	DIODE ASSY.
4	1	7-90-07462	WIRE (77A)
5	1	8-06-05004	ISOLATOR
6	1	2-00-04564	CABLE CLAMP

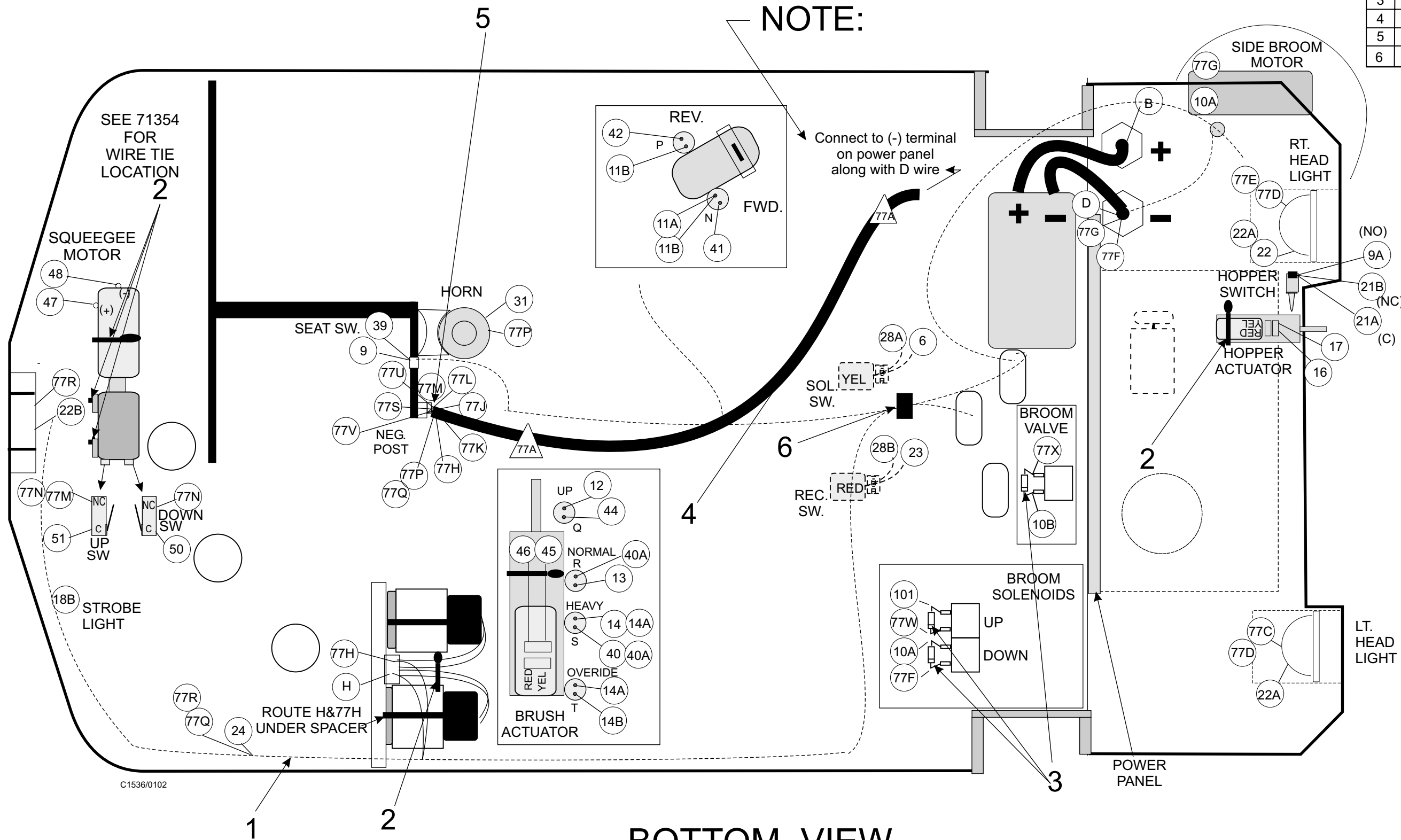

NOTE:

Connect to (-) terminal on power panel along with D wire

BOTTOM VIEW

C1536/0102

**HYDRAULIC SCHEMATIC (BATTERY)**

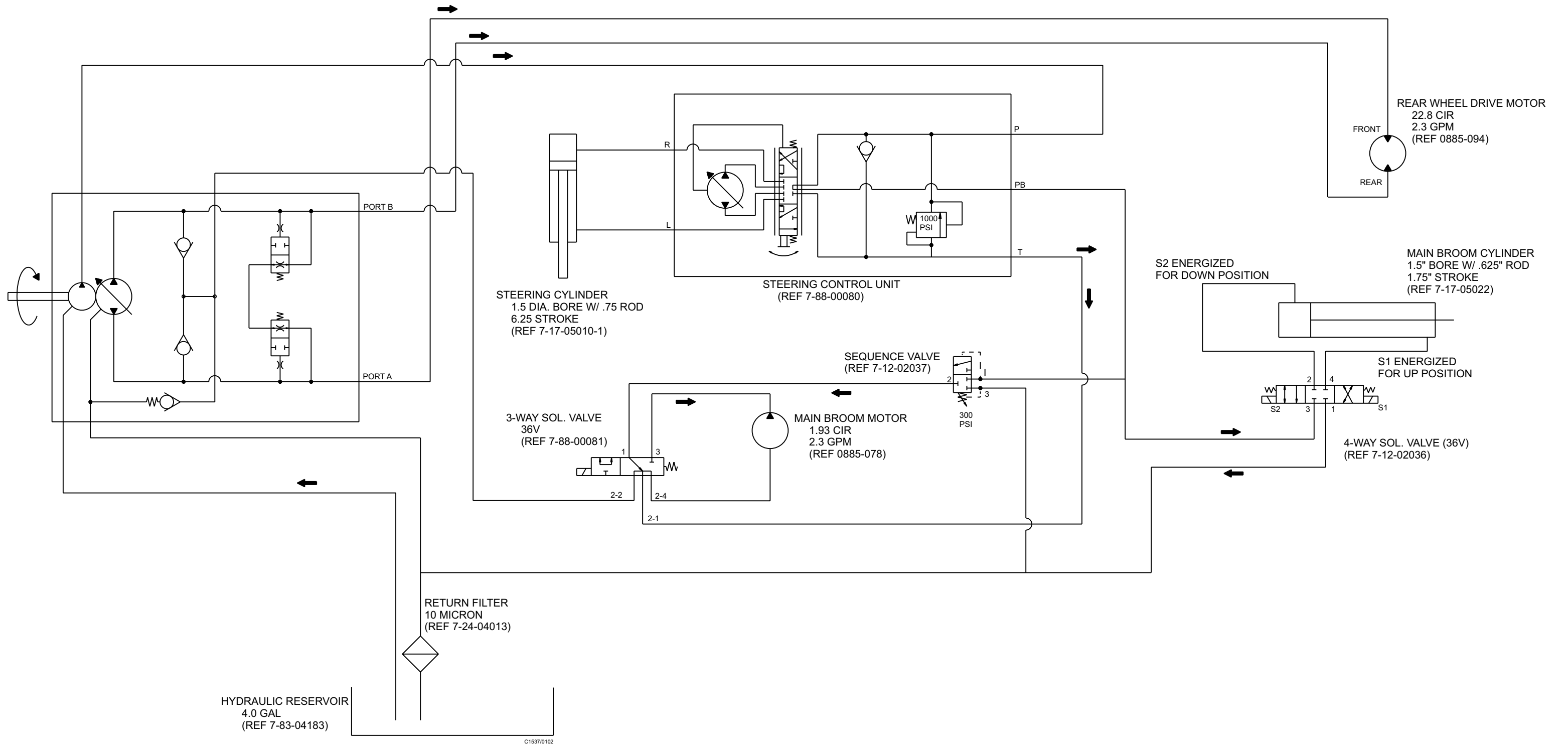



## CHAPTER 2 TABLE OF CONTENTS

Main Broom .....	2-2
Main Broom Baffle and Flaps .....	2-6
Side Broom (12V & 36V) .....	2-8
Hopper Assembly (12V & 36V Battery) .....	2-10
Scrub Deck Actuator .....	2-12
Scrub Deck Assembly (40") .....	2-14
Scrub Deck Assembly (46") .....	2-17
Side Squeegee (40") .....	2-19
Side Squeegee (46") .....	2-20
Rear Squeegee (40") .....	2-22
Rear Squeegee (46") .....	2-24
Rear Squeegee Lift System (12V and 36V) .....	2-26
Swing Squeegee Support .....	2-28
Solution Tank .....	2-30
Solution Control .....	2-32
Recovery Tank .....	2-34
Forward and Reverse Control (Battery) .....	2-36
Brake Assembly .....	2-38
Front Wheel Assembly .....	2-40
Rear Wheel Assembly .....	2-42
Front Cover and Latch Assembly .....	2-44
Seat Assembly .....	2-46
Access Panels .....	2-47
Roll Out Battery .....	2-48
Dust Control (Battery) .....	2-50
Vacuum Manifold System .....	2-54
Hydraulic Motor and Pump Assembly .....	2-56
Motor and Pump Mounting Assembly .....	2-58
Hydraulic Reservoir Assembly .....	2-59
Hydraulic Filter and Solenoid Assembly .....	2-60
Hydraulic Connection Diagram .....	2-62
Power Panel (36V) .....	2-64
Power Panel (36V) Cont. ....	2-66
Power Panel (36V) Cont. ....	2-68
Power Steering .....	2-70
Electrical Power Panel (36V) .....	2-72
Instrument Panel .....	2-74
Instrument Panel (12V) .....	2-76
Decals .....	2-78
Notes .....	2-80

## **MAIN BROOM ASSEMBLY - PARTS LIST**

---

<b><u>Key No.</u></b>	<b><u>Part Number</u></b>	<b><u>Description</u></b>	<b><u>Qty.</u></b>
1	7-08-01012	Bracket - Main/Side Broom Adjustment	1
2	7-03-04207	Arm - Main/Side Broom Adjustment	1
3	7-60-00160	Pulley - Cable	1
4	7-13-07130	Clip - Cable Ret.	1
5	7-03-04191	Arm Assembly - Main Broom	1
6	7-23-03056	Nut	2
7	7-39-00032	Knob - 5/16 x 2	1
8	2-95-04182	Nut - 3/8-16 Elastic Stop Nut	5
9	7-14-01021	Clevis - Broom Cylinder	1
10	7-17-05022	Cylinder - Broom	1
11	7-14-01022	Clevis - Broom	1
12	7-10-00041	Cable - Main Broom	1
13	2-00-04892	Fitting - 90° Elbow (O-ring)	Ref.
14	7-55-08168	Pin - Pivot	1

### **HARDWARE USED:**

H15	2-00-00221	Screw, 1/4-20 x .750 HHC	2
H17	2-00-00205	Screw, ¼-20 x 1.000 HCC	1
H26	2-00-00641	Nut, 1/4-20 Insert Fiber	1
H27	2-00-03702	Washer, .625 x .281 x .063	1
H36	2-00-00196	Carriage Bolt, 5/16-18 x 1.000	1
H39	2-00-00218	Screw, 5/16-18 x 2.000 HHC	1
H43	2-00-00409	Flat Washer, .687 x .344 x .062	5
H46	2-00-00644	Nut, 5/16-18, Insert Fiber	6
H49	2-00-00209	Screw, 3/8-16 x 1.250 HHC	5
H237	2-00-05356	Screw, 5/16-18 x 1.25 Grade 8	2
H358	2-00-03016	Screw - ¼-28 x ¼ set	1
H359	2-00-05473	Screw - 3/8 x 1 Sc. HD Cap	1
H360	2-00-05455	5/16-18 x ½ Shldr. Screw Stl	1

C1904/0102

**MAIN BROOM ASSEMBLY- EXPLODED VIEW**

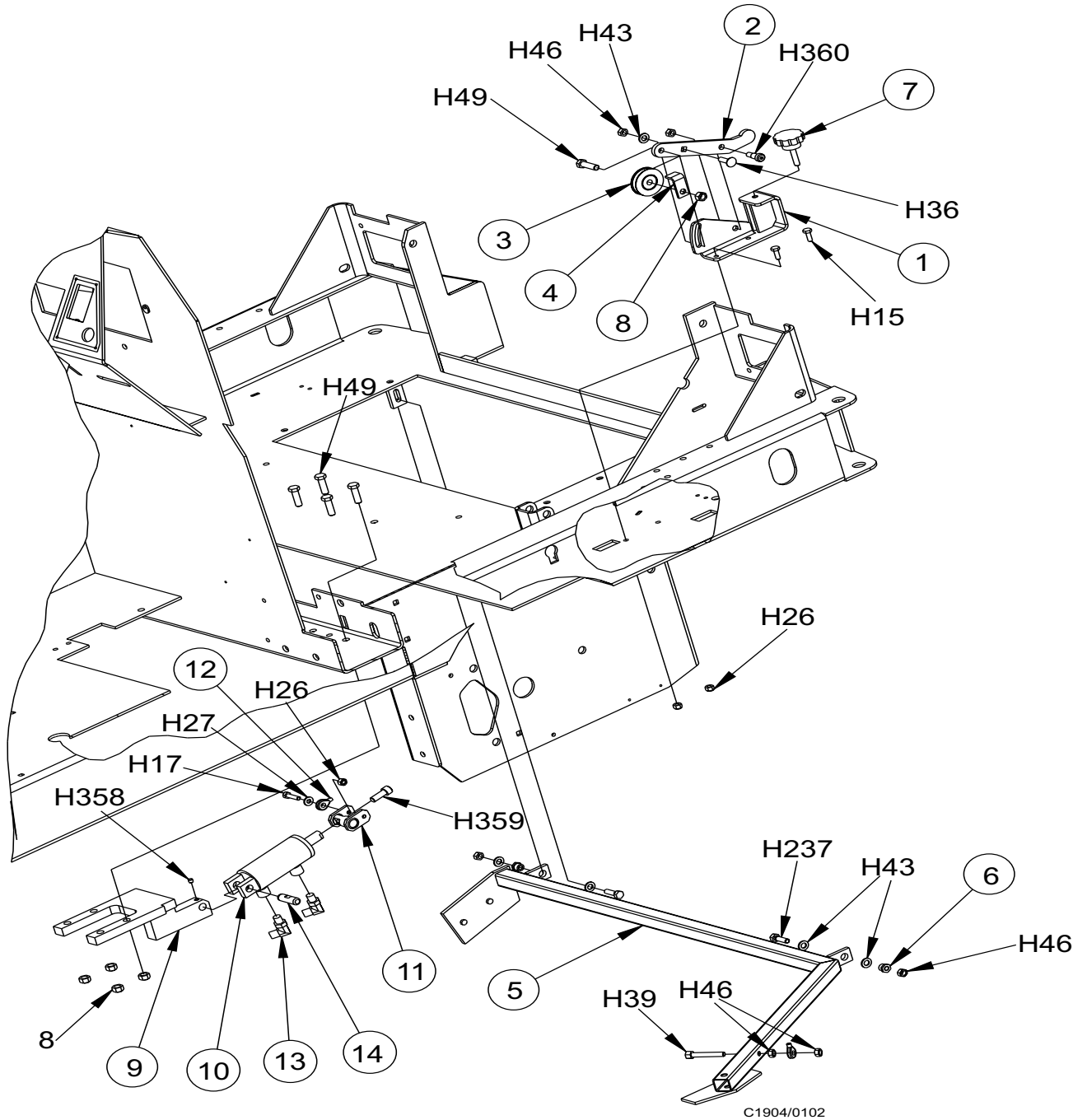

**MAIN BROOM ASSEMBLY (cont.) - PARTS LIST**

---

<u>Key No.</u>	<u>Part Number</u>	<u>Description</u>	<u>Qty.</u>
1	7-03-04190	Arm Main Broom	1
2	8-30-05112	Guard	1
3	2-00-03306	Bearing - Ball	2
4	8-75-01147	Spacer - Idler Main Broom	1
5	2-00-03158	Spacer	1
6	8-33-09059	Idler Hub	1
7	7-08-00938	Bracket, Main Broom	1
8	8-30-05116	Guard - Thread	1
9	8-33-05086	Housing - Main Broom Motor Weldment	1
10	0885-078	Hydraulic Motor - (Broom Drive)	Ref.
11	8-08-03137	Broom - Main	Ref.
12	2-00-05435	Fitting - 90 Orfs to Ors Boss 06 x 06	Ref.
13	2-00-05442	Fitting - Orfs M to Orfs M Boss 06 x 06	Ref.
14	25201A	Knob	2
15	8-33-09062	Weldment - Hub, Main Broom	1

**HARDWARE USED:**

H15	2-00-00221	Screw, 1/4-20 x .750 HHC	4
H26	2-00-00641	Nut, 1/4-20 Insert Fiber	2
H46	2-00-00644	Nut, 5/16-18, Insert Fiber	1
H61	2-00-02616	Screw, 1/2-13 x 3.000 HHC	1
H63	2-00-02312	Lock Washer, 1/2 HS Med.	1
H64	2-00-00596	Nut, Hex. 1/2-13 x .750 x .437	1
H72	2-00-00518	Lock Washer, Helical Spring	5
H87	2-00-00263	Set Screw, 1/4-20 x .250 HSKCP	2
H150	2-00-00211	Screw, 5/16-18 x 1.750 HCC	1
H318	2-00-04750	Screw BTN HD SKT	3

C1937/0102

**MAIN BROOM ASSEMBLY (cont.) - EXPLODED VIEW**

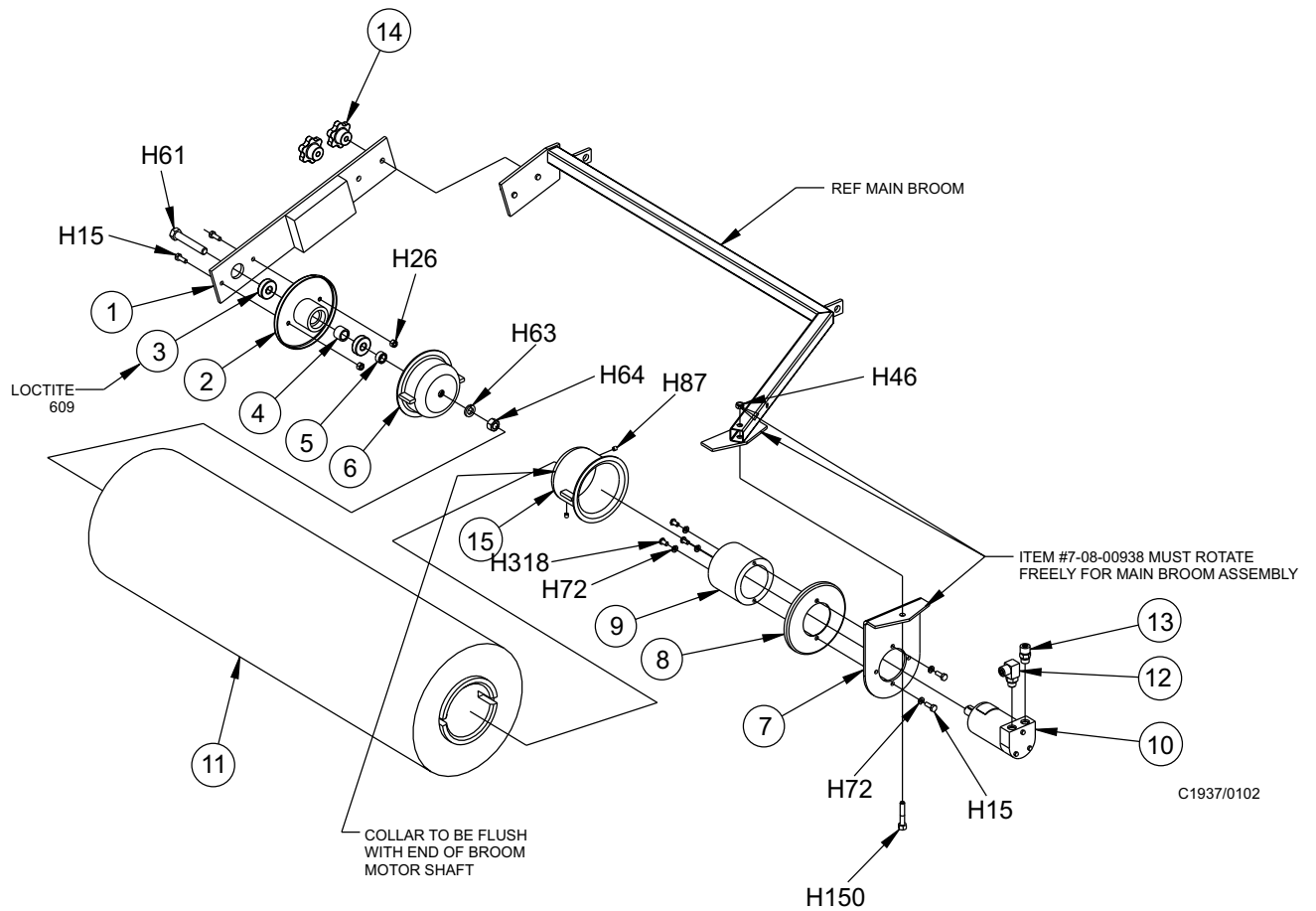

C1937/0102

## **MAIN BROOM BAFFLE AND FLAPS - PARTS LIST**

<b>Key No.</b>	<b>Part Number</b>	<b>Description</b>	<b>Qty.</b>
1	7-27-07196	Main Frame Weldment	1
2	7-66-05011-1	Roller-Bumper	5
3	7-32-00042	Hinge - Main Broom Baffle	1
4	7-05-01003	Baffle - Main Broom	1
5	7-13-07203	Clamp - Main Broom Chamber Rear Flap	3
6	7-25-08088	Flap - Main Broom Right Side	1
7	7-13-07207	Clamp - Flap (Left)	1
8	7-13-07206	Clamp - Flap (Right Hand Front)	1
9	7-25-08089	Flap - Main Broom Left Side	1
10	7-13-07204	Clamp - Flap (Left)	1
11	7-16-07418	Cover Dust Cover	1
12	7-70-05175	Pin - Roller Bumper	3
13	2-00-00540	Ring - Ret. Est. #5100 - 75 for 3/4 D.	8
14	7-70-05188	Pin - Roller Bumper, Side Broom	1
15	7-32-00039	Hinge - Hopper	1
16	7-52-00172	Panel - Broom Door	1
17	25201A	Knob	1
18	7-25-08090	Flap - Main Broom Door Panel	1
19	7-13-07205	Clamp - Flap (Panel)	1
20	7-29-00256	Gasket - Main Broom Chamber (Middle)	1
21	7-29-00257	Gasket - Main Broom Chamber (RH)	1
22	7-25-08091	Flap - Main Broom Rear	1
23	7-29-00263	Gasket - Dust Control	1
24	7-29-00258	Gasket - Main Broom Chamber (LH)	1

### **HARDWARE USED:**

H15	2-00-00221	Screw, 1/4 - 20 x .750 HHC	5
H26	2-00-00641	Nut, 1/4 - 20 Insert Fiber	13
H27	2-00-03702	Washer, .625 x .281 x .063	3
H34	2-00-00208	Screw, 5/16 - 18 x .750 HHC	7
H36	2-00-00196	Carriage Bolt, 5/16 - 18 x 1.000	1
H43	2-00-00409	Flat Washer, .687 x .344 x .062	7
H44	2-00-00530	Lock washer, 5/16 HS Med.	4
H46	2-00-00644	Nut, 5/16 -18 Insert Fiber	4
H79	2-00-01676	Flat Washer, 1.062 x .265 x .062	1
H86	2-00-03575	Bolt Carriage, .25-20 x .75 GR 5 ZN	8
H136	2-00-03940	Screw, #10 - 24 x .500 T/C HH	16
H238	2-00-03750	Carriage Bolt, .38-16 x 1.50	1

C1900/0102

# MAIN BROOM BAFFLE AND FLAPS - EXPLODED VIEW

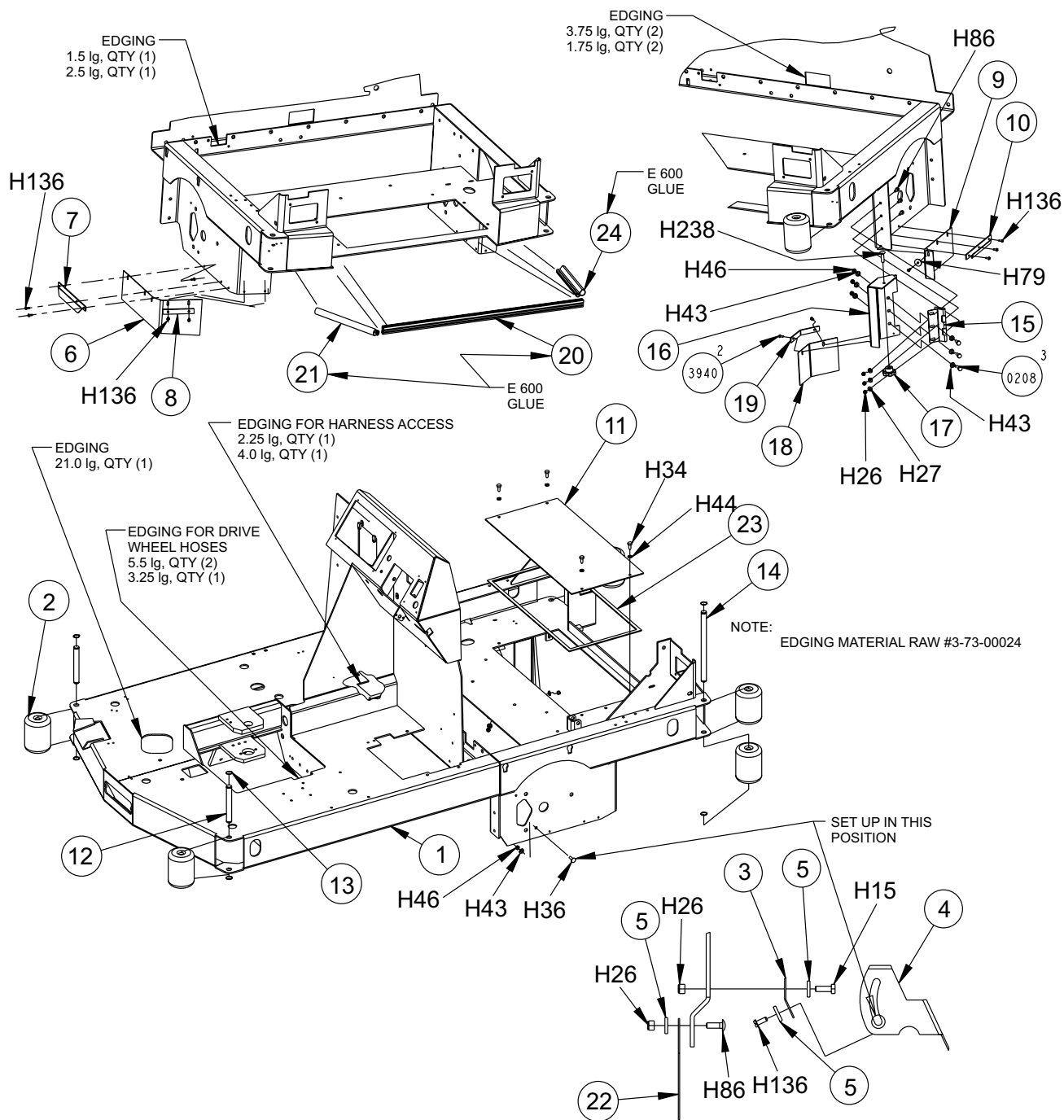

C1900/0102

## **SIDE BROOM (12 & 36V)- PARTS LIST**

---

<b><u>Key No.</u></b>	<b><u>Part Number</u></b>	<b><u>Description</u></b>	<b><u>Qty.</u></b>
1	7-03-04189	Arm - Side Broom	1
2	0885-082	Motor Gear Unit - Side Broom (36V)	1
3	7-25-06035	Flange - Broom Mount	1
4	8-08-03215	Side Broom	1
5	2-00-00263	Motor - Electric (1/2 H.P., 36V)	2
6	2-00-04578	Terminal (.156 Male)	1
7	2-00-04626	Terminal (.156 Female)	1
8	7-66-056011-1	Roller - Bumper	Ref.
9	7-16-07413	Cover - Side Broom	1
10	2-00-05330	Threaded Insert - 5/16-18	1
11	7-75-01194	Spacer - Side Broom Cover	1
12	7-70-05188	Pin - Roller Bumper, Side Broom	Ref.
13	2-00-00540	Ring - Rt. Ext. #5100-75 for 3/4 D.	Ref.
14	2-00-01915	Grommet	1
15	7-08-01012	Bracket - Main/Side Broom Adjustment	1
16	7-03-04207	Arm - Main/Side Broom Adjustment	1
17	7-39-00032	Knob - Broom Adjustment	1
18	7-60-00160	Pulley - Cable	1
19	7-13-07130	Clip - Cable Ret.	1
20	2-95-04182	Nut - 3/8-16 Elastic Stop Nut	1
21	7-10-00042	Cable - Side Broom	1

### **HARDWARE USED:**

H15	2-00-00221	Screw, 1/4-20 x .750 HHC	6
H17	2-00-00205	Screw, 1/2-20 x 1.000 HHC	1
H22	2-00-02589	Screw, 1/4-20 x 2.000 HHC	3
H26	2-00-00641	Nut, 1/4-20 Insert Fiber	6
H27	2-00-03702	Washer, .625 x .281 x .063	4
H36	2-00-00196	Carriage Bolt, 5/16-18 x 1.000	1
H38	2-00-00225	Screw, 5/16-18 x 1.500 HHC	1
H43	2-00-00409	Flat Washer, .687 x .344 x .062	3
H44	2-00-00530	Lock Washer, 5/16 HS Med.	1
H46	2-00-00644	Nut, 5/16-18, Insert Fiber	4
H49	2-00-00209	Screw, 3/8-16 x 1.250 HHC	1
H57	2-00-00240	Screw, 1/2-13 x 1.250 HHC	1
H65	2-00-04936	Nut, 1/2-13 Fibre Lock	1
H72	2-00-00518	Lock Washer, Helical Spring	4
H360	2-00-05455	5/16-18 x 1/2 Shldr. Screw Stl	1

C1928/0102

**SIDE BROOM (12 & 36V) - EXPLODED VIEW**

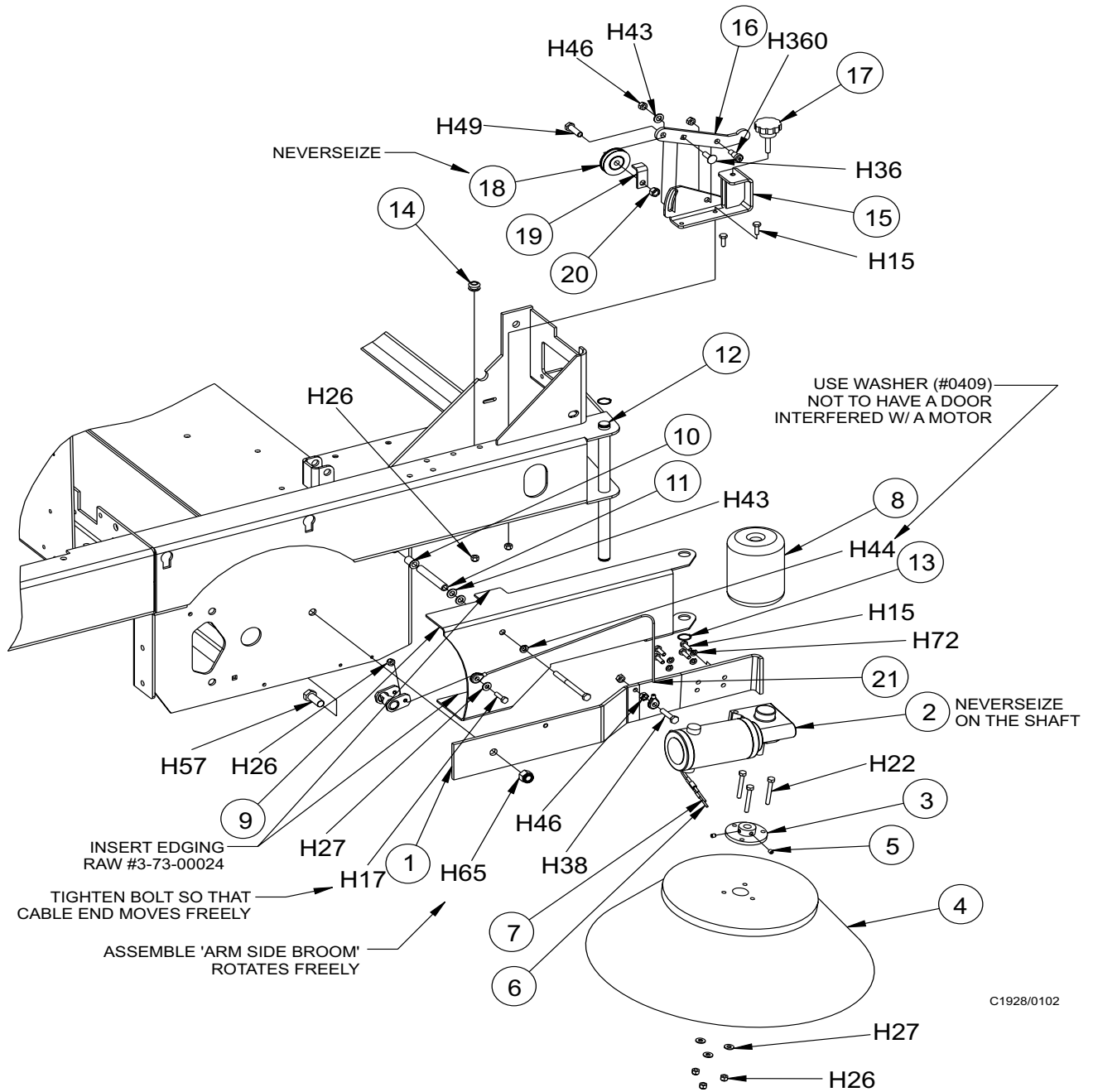

C1928/0102

## HOPPER ASSEMBLY (12V & 36V BATTERY) - PARTS LIST

<u>Key No.</u>	<u>Part Number</u>	<u>Description</u>	<u>Qty.</u>
^1	0782-090-1	12 Volt - Dump Door Actuator	1
*2	0782-130	36 Volt - Dump Door Actuator	1
3	7-03-04209	Arm - Hopper Safety	1
4	7-08-00974	Bracket - Hopper Switch Mnt.	1
5	7-13-07201	Clamp - Hopper	1
6	7-25-08092	Flap - Hopper	1
7	7-29-00259	Gasket - Hopper	2
8	7-32-06026	Hopper - Power Dump (Weldment)	1
9	2-95-04182	Nut, 3/8-16 Elastic Stop Nut	2
10	2-00-05320	Pin - Hairpin Cotter	1
11	7-55-08167	Pin - Hopper Shear	1
12	7-76-00121	Spring - Hopper Safety	1
13	8-82-00058	Switch	1

^0782-090-1 used for I.C. machines only

\*0782-130 used for Battery machines only

### **HARDWARE USED:**

H14	2-00-00219	Screw, 1/4-20 x .500 HHC	1
H15	2-00-00221	Screw, 1/4-20 x .750 HHC	6
H26	2-00-00641	Nut, 1/4-20 Insert Fiber	6
H27	2-00-03702	Washer, .625 x .281 x .063	1
H33	2-00-00224	Screw, 5/16-18 x .500 HHC	1
H34	2-00-00208	Screw, 5/16-18 x .750 HHC	1
H43	2-00-00409	Flat Washer, .687 x .344 x .062	2
H46	2-00-00644	Nut, 5/16-18, Insert Fiber	1
H62	2-00-00405	Flat Washer, 1.063 x .531 x .094	3
H65	2-00-04936	Nut, 1/2-13 Fiber Lock	1
H73	2-00-00247	Screw, 1/2-13 x 2.500 HHC	1
H89	2-00-01372	Nut, Fiber Insert #8-32 Steel	2
H121	2-00-00090	Screw, #8-3 x 1.500 RHM	2
H159	2-00-00512	Lock Washer	2
H320	2-00-05424	Screw, Shoulder 1/2-1/2	2

C1918/0007

**HOPPER ASSEMBLY (12V & 36V BATTERY)- EXPLODED VIEW**

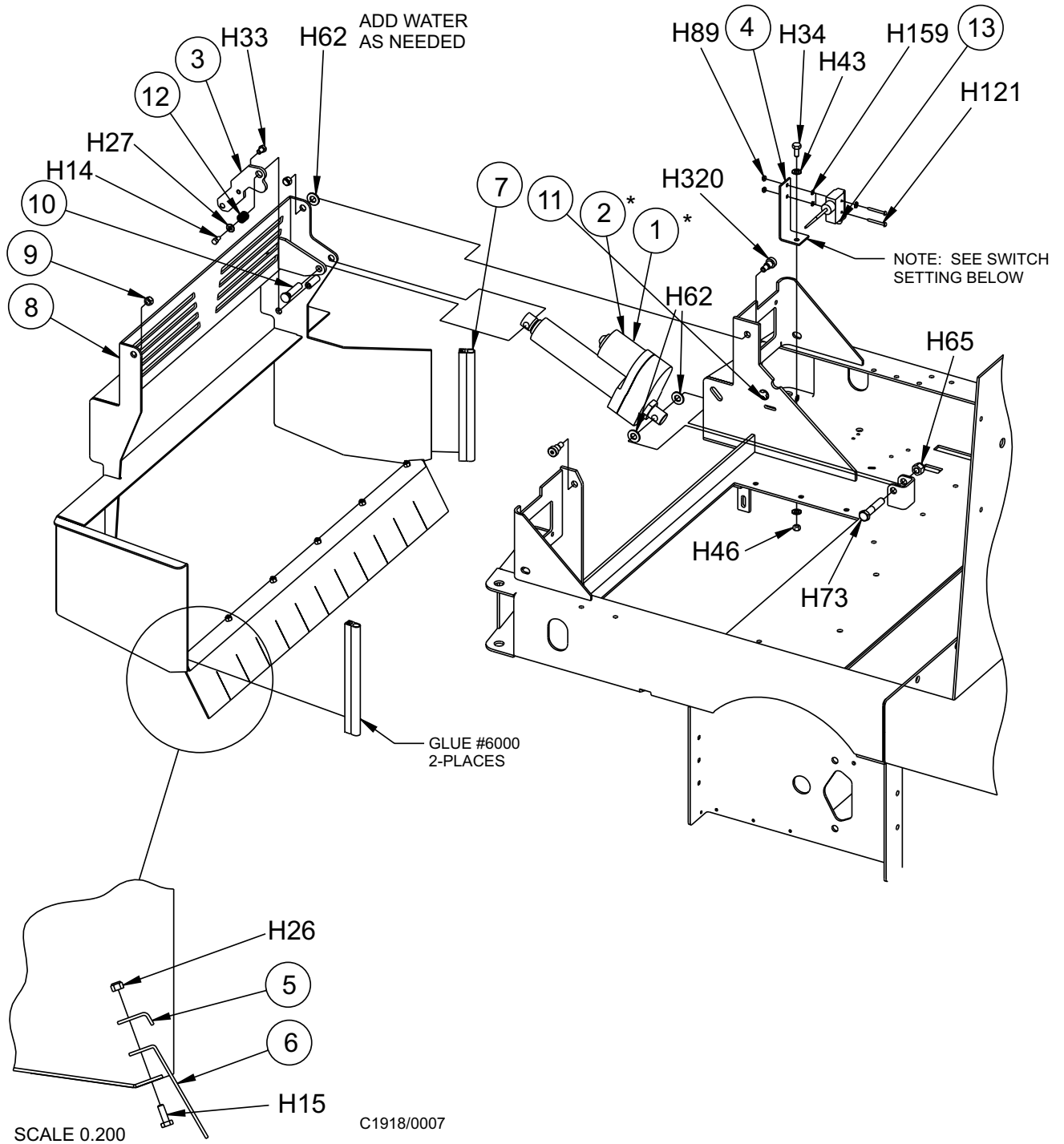

## **SCRUB DECK ACTUATOR ASSEMBLY - PARTS LIST**

---

<b><u>Key No.</u></b>	<b><u>Part Number</u></b>	<b><u>Description</u></b>	<b><u>Qty.</u></b>
1	7-81-00234	Support - Actuator	1
2	7-75-01207	Spacer - Act Arm	2
3	7-03-04213	Arm - Scrub Deck Lift	1
4	7-57-05055	Pivot - Brush Lift Lever	1
5	0782-106	Actuator - Squeegee Lift (36V)	1
6	7-55-08165	Pin - Actuator Pivot	1
7	8-15-01016	Collar	4
8	8-76-00051	Spring - Transmission Centering	2
9	8-15-01002	Collar - Setscrew	2
10	8-33-09008	Hom	1
11	7-08-02022	Bracket - Sliding	1
12	7-82-00045	Switch - Proximity (Normally Open)	2
13	7-82-00046	Switch - Proximity (Normally Closed)	2
14	2-00-05466	Pin - Clevis	1
15	2-00-00775	Cotter Pin (1/8 Dia. x 1 Lg.)	1
16	2-00-00767	Cotter Pin	1
17	7-42-05168	Link - Lift Assembly, 40"	Ref.
18	8-06-05004	Terminal Block	1

### **Hardware Used:**

H8	2-00-00039	Screw, 10-24 x 1.000 RHM	1
H12	2-00-01246	Nut, Hex Fiber Insert #10-24	1
H35	2-00-02708	Screw, 5/16-18 x 1.000 HHM	2
H44	2-00-00530	Lock Washer, 5/16 Med.	6
H45	2-00-00585	Nut, Hex. 5/16-18 x .500 x .265	6
H55	2-00-00643	Nut, 3/8-16 Stop	3
H59	2-00-00242	Screw, 1/2-13 x 2.250 HHC	1
H62	2-00-00405	Flatwasher, 1.063 x .531 x .094	3
H65	2-00-04936	Nut, 1/2 - 13 Fiber Lock	1
H150	2-00-00211	Screw, 5/16-18 x 1.750 HCC	2
H226	2-00-04689	Washer, 11/16 OD x .260 ID x .050	2
H371	2-00-05487	3/8-16 x 0.75 Carriage Bolt	3

C1956/0102

**SCRUB DECK ACTUATOR ASSEMBLY- EXPLODED VIEW**

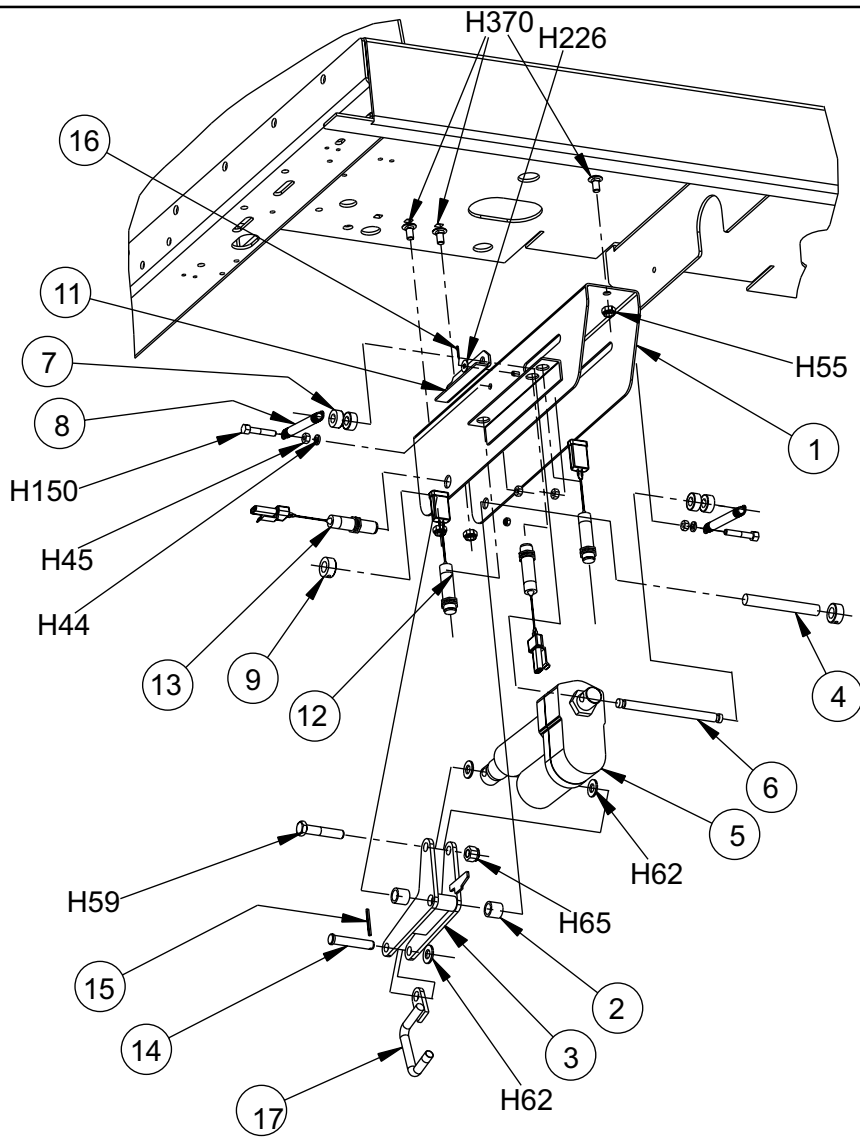

c1956/0102

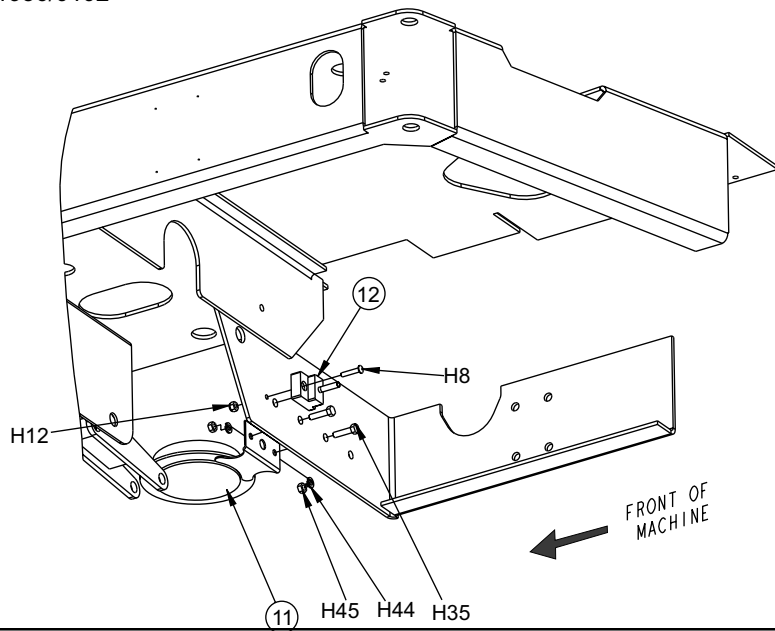

FRONT OF MACHINE

## **SCRUB DECK ASSEMBLY (40") - PARTS LIST**

---

<b><u>Key No.</u></b>	<b><u>Part Number</u></b>	<b><u>Description</u></b>	<b><u>Qty.</u></b>
1	7-27-07202	Frame - Brush Drive (40")	1
2	0760-542	Mtr & Reducer Assembly	2
3	2-00-03761	Key, ¼ sq. x 1.75 Steel	2
4	7-33-09042	Hub - Brush Drive	2
5	7-03-04123	Arm, Brush Drive	2
6	7-41-00027	Latch, Brush Driver	2
7	7-88-00073	Valve - Solution (36VDC)	2
8	2-00-04564	Clamp - Cable	1
9	2-00-05447	Tee - Plastic (3/4")	1
10	7-55-08151	Pin - Lock Up	2
11	2-00-05253	Clamp	1
12	8-66-00144	Rod End	1
13	7-42-05168	Lik - Lift Assembly, 40"	1

### **HARDWARE USED:**

H15	2-00-00221	Screw, 1/4-20 x .750 HHC	8
H26	2-00-00641	Nut, 1/4-20 Insert Fiber	8
H27	2-00-03702	Washer, .625 x .281 x .063	2
H39	2-00-00218	Screw, 5/16-18 x 2.000 HHC	2
H49	2-00-00209	Screw, 3/8-16 x 1.250 HHC	6
H52	2-00-00402	Flat Washer, .750 x .390 x .094	6
H53	2-00-02310	Lock Washer, Helical Spring 3/8 Med.	6
H64	2-00-00596	Nut, Hex ½-13 x .750 x .437	6
H68	2-00-00640	Nut, Hex Fiber Insert 1/2-20	1
H225	2-00-04851	Washer, Engine Mount	4
H243	2-00-00591	Nut, Hex-Jam .50-20	2
H372	2-00-02691	3/8-16 x 0.75 Carriage Bolt	1

C1922/0102

# SCRUB DECK ASSEMBLY (40")- EXPLODED VIEW

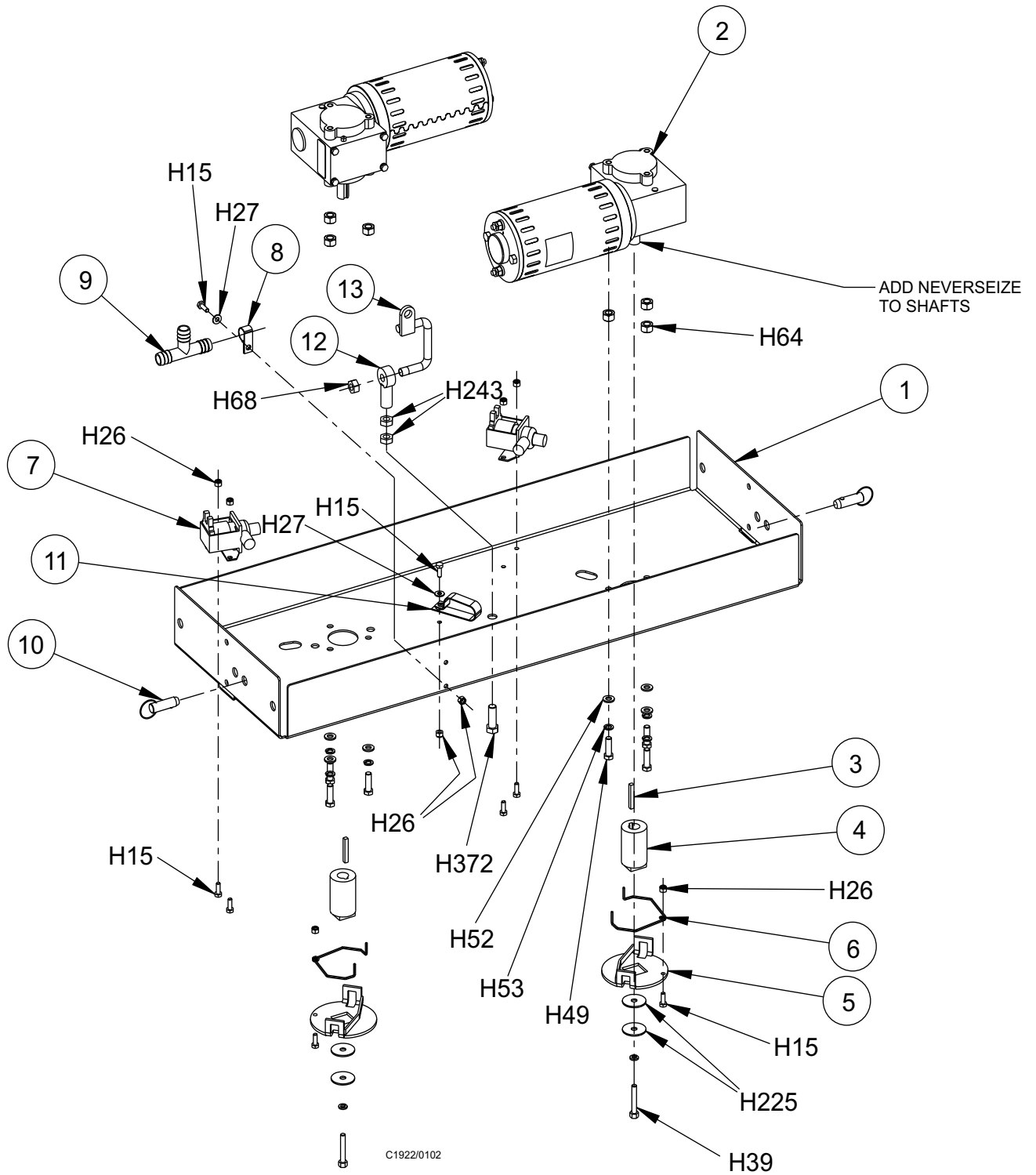

# SCRUB DECK ASSEMBLY (40")

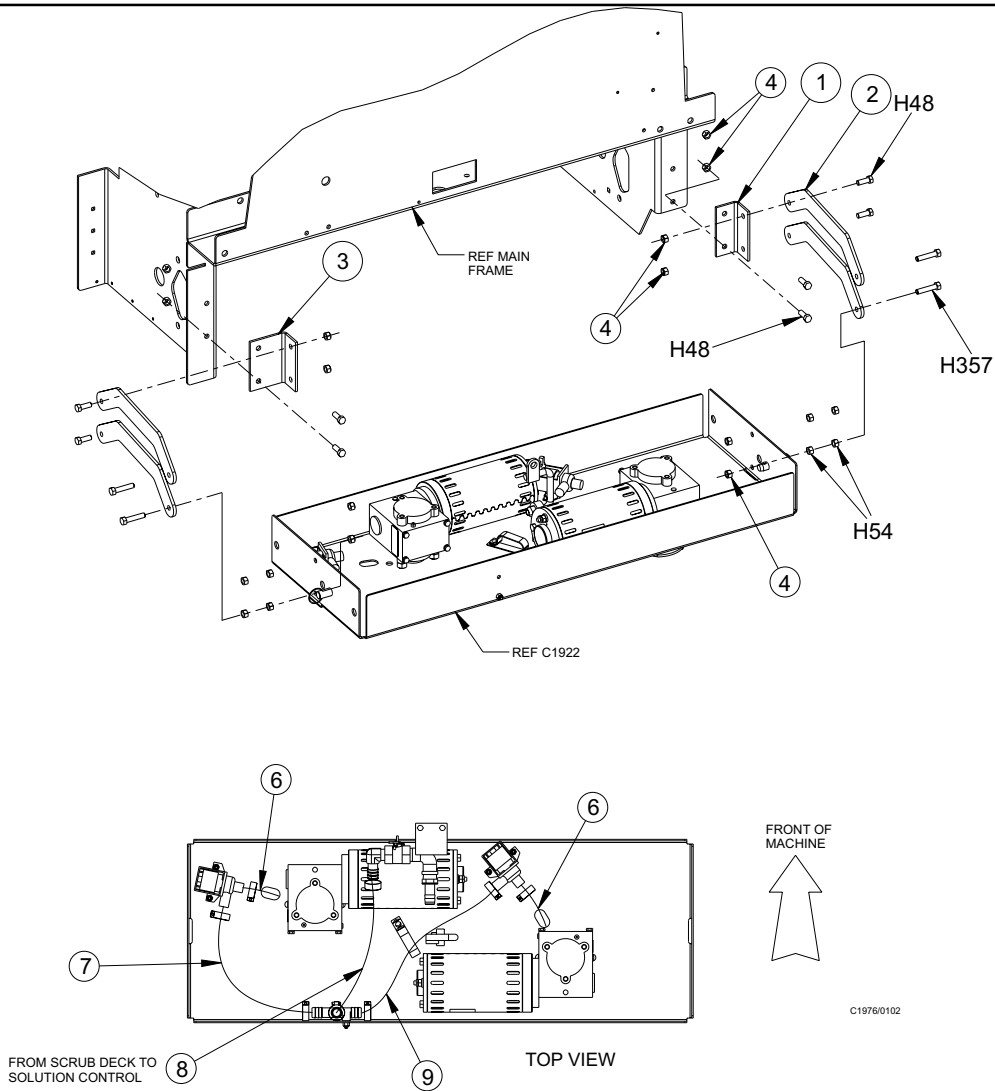

<u>Key No.</u>	<u>Part Number</u>	<u>Description</u>	<u>Qty.</u>
1	7-57-05057	Pivot - Scrub Deck (R.H.)	1
2	7-42-05163	Link Bar (40")	4
3	7-57-05058	Pivot - Scrub Deck (L.H.)	1
4	2-95-04182	Nut - 3/8-16 Elastic Stop Nut	12
5	2-00-02220	Hose Clamp	7
6	7-33-02424	Hose - Solution Feed	2
7			
8	7-33-02430	Hose - Heater (3/4 ID x 15.5 Lg.)	1
9	7-33-02398	Hose - Heater (3/4 ID x 14.75 Lg.)	1
10	7-33-02440	Hose - Heater (3/4 ID x 17.00 Lg.)	1

## HARDWARE USED:

H48	2-00-00233	Screw, 3/8-16 x 1.000 HHC	8
H54	2-00-02360	Nut, 3/8-16 Hex	8
H357	2-00-05385	Screw - HHM .375-16 x 1.75	4

C1976/0101

## SCRUB DECK ASSEMBLY (46")

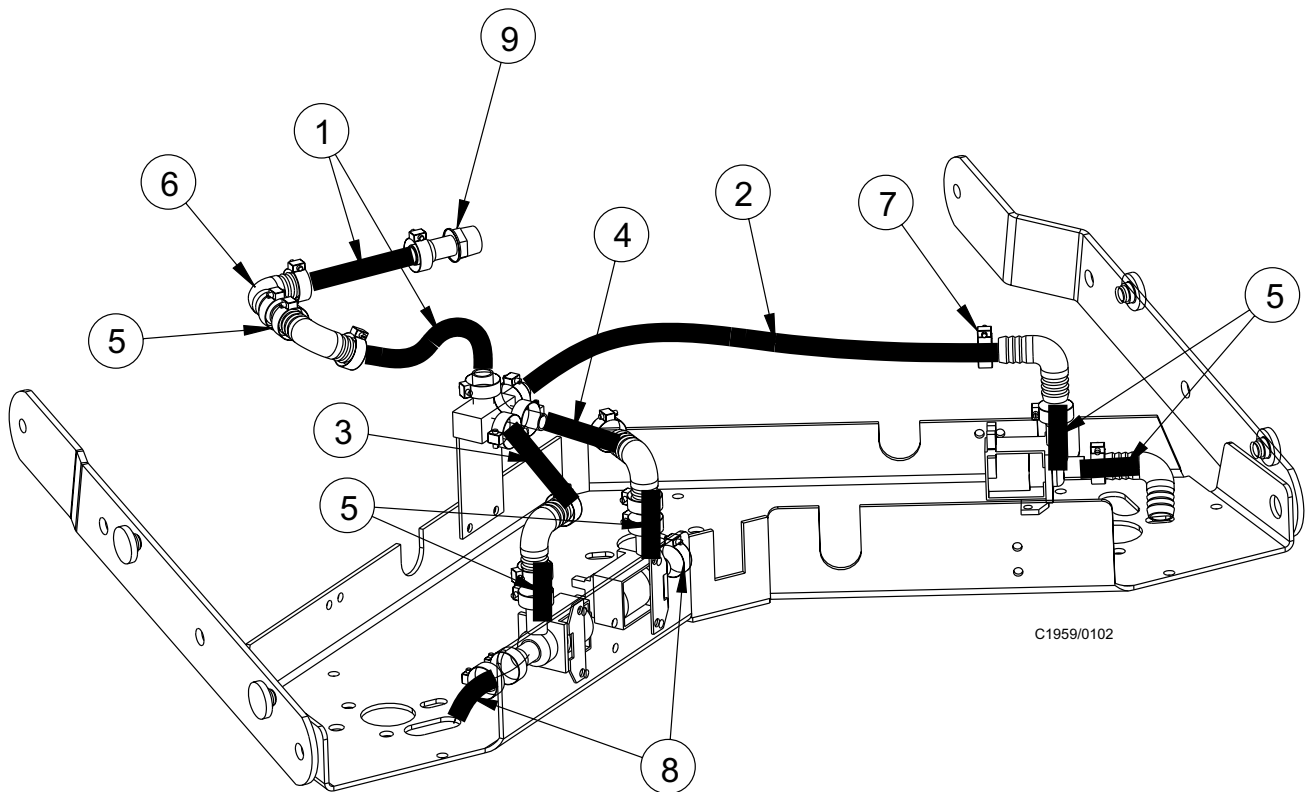

<u>Key No.</u>	<u>Part Number</u>	<u>Description</u>	<u>Qty.</u>
1	7-33-02445	Heater Hose (3/4 x 5.5 lg)	1
2	7-33-02421	Heater Hose (5/8 x 21 lg)	1
3	7-33-02422	Heater Hose (5/8 x 11.5 lg)	1
4	7-33-02423	Heater Hose (5/8 x 6.5 lg)	1
5	7-33-02434	Heater Hose (3/4 x 2 lg)	5
6	2-00-05380	Fitting - 90° Elbow	5
7	2-00-02220	Hose Clamps	20
8	7-33-02424	Hose - Heater Hose	2
9	7-25-02012	Hose Fitting - Straight	Ref.

C1959/0102

## **SCRUB DECK ASSEMBLY (46")- PARTS LIST**

---

<b><u>Key No.</u></b>	<b><u>Part Number</u></b>	<b><u>Description</u></b>	<b><u>Qty.</u></b>
1	7-27-07200	Brush Frame (46")	1
2	0760-542	Mtr & Reducer Assembly	3
3	2-00-03761	Key - 1/4 Sq. x 1.75 Steel	3
4	7-33-09042	Hub - Brush Drive	3
5	7-03-04123	Arm - Brush Drive (Weldment)	3
6	7-41-00027	Latch - Brush Driver	3
7	7-88-00073	Valve - Solution (36VDC)	1
8	7-88-00082	Valve - Solution (36 VDC)	1
9	7-48-00038	Water Weldment	1
10	7-88-00073	Valve - Solution (36VDC)	1
11	7-57-05058	Pivot - Scrub Deck (LH)	1
12	7-57-05057	Pivot - Scrub Deck (RH)	1
13	7-42-05160	Link - Brush Frame - 46" (RH)	1
14	7-55-08151	Pin-Lock up	2
15	7-42-05161	Link - Brush Frame - 46" (LH)	1
16	2-95-04182	Nut - 3/8-16 Elastic Stop Nut	6
17	7-09-01143	Bushing-Brush Lift	2
18	8-66-00144	Rod End	1
19	7-42-05168	Link - Lift Assembly, 46"	1

### **HARDWARE USED:**

H15	2-00-00221	Screw, 1/4-20 x .750 HHC	11
H26	2-00-00641	Nut, 1/4-20 Insert Nut	11
H38	2-00-00225	Screw, 5/16-18 x 1.500 HHC	2
H39	2-00-00218	Screw, 5/16-18 x 2.000 HHC	3
H46	2-00-00644	Nut, 5/16-18, Insert Fiber	2
H48	2-00-00233	Screw, 3/8-16 x 1.000 HHC	6
H49	2-00-00209	Screw, 3/8-16 x 1.250 HHC	9
H52	2-00-00402	Flat Washer, .750 x .390 x .094	9
H53	2-00-02310	Lock Washer, Helical Spring 3/8 Med.	9
H64	2-00-00596	Nut, Hex. 1/2-13 x .750 x .437	9
H68	2-00-00460	Nut, Hex Fiber Insert 1/2-20	1
H225	2-00-04851	Washer, Engine Mount	6
H243	2-00-00591	Nut, Hex-Jam .50-20	2
H350	2-00-00451	Flatwasher .750 x .312 x .065 Stl. Zn.	2
H365	2-00-04182	Bushing	2
H372	2-00-02691	3/8-16 x 0.75 Carriage Bolt	1

C1958/00102

**SCRUB DECK ASSEMBLY (46") - EXPLODED VIEW**

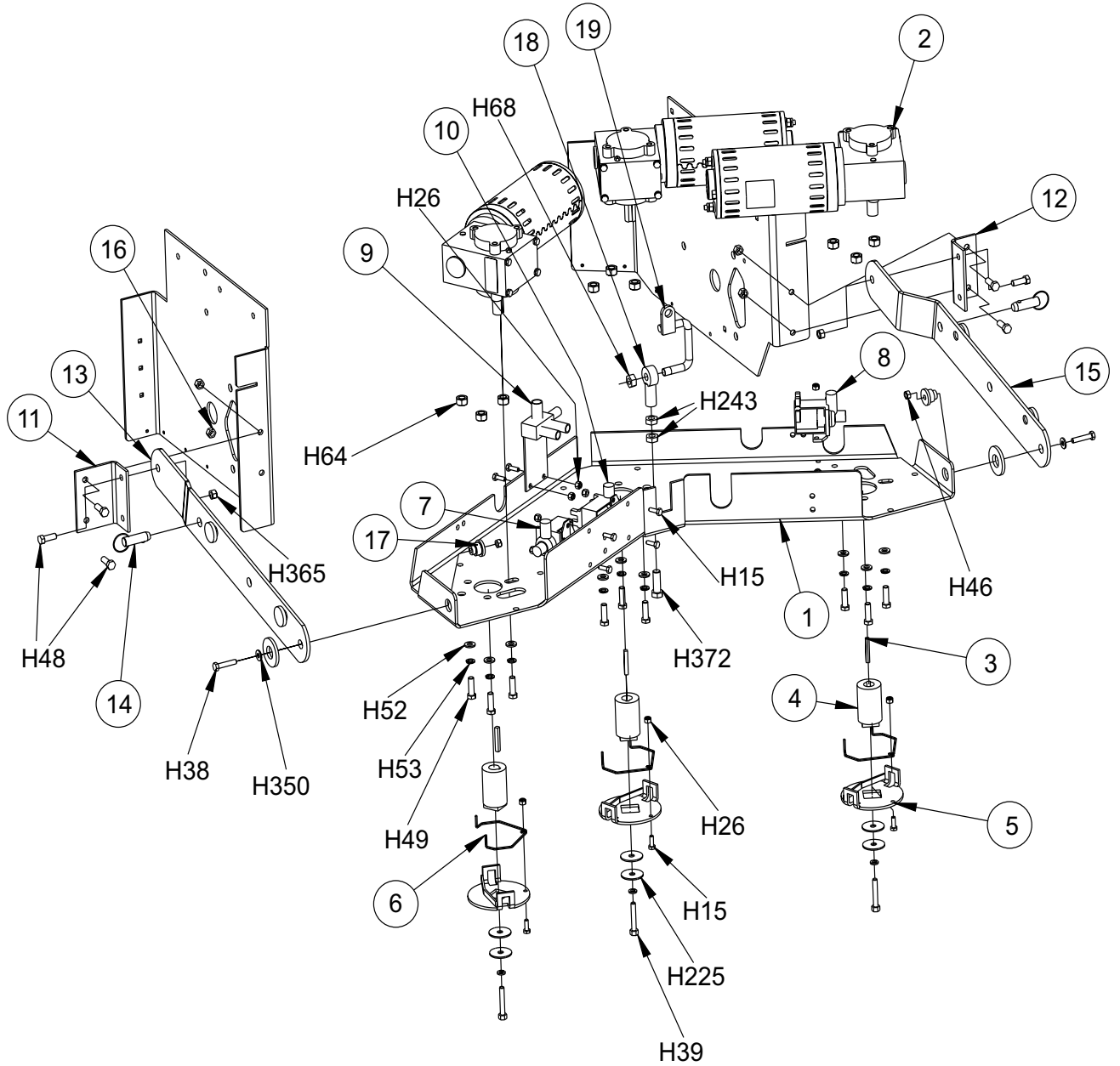

C1958/0102

# SIDE SQUEEGEE (40")

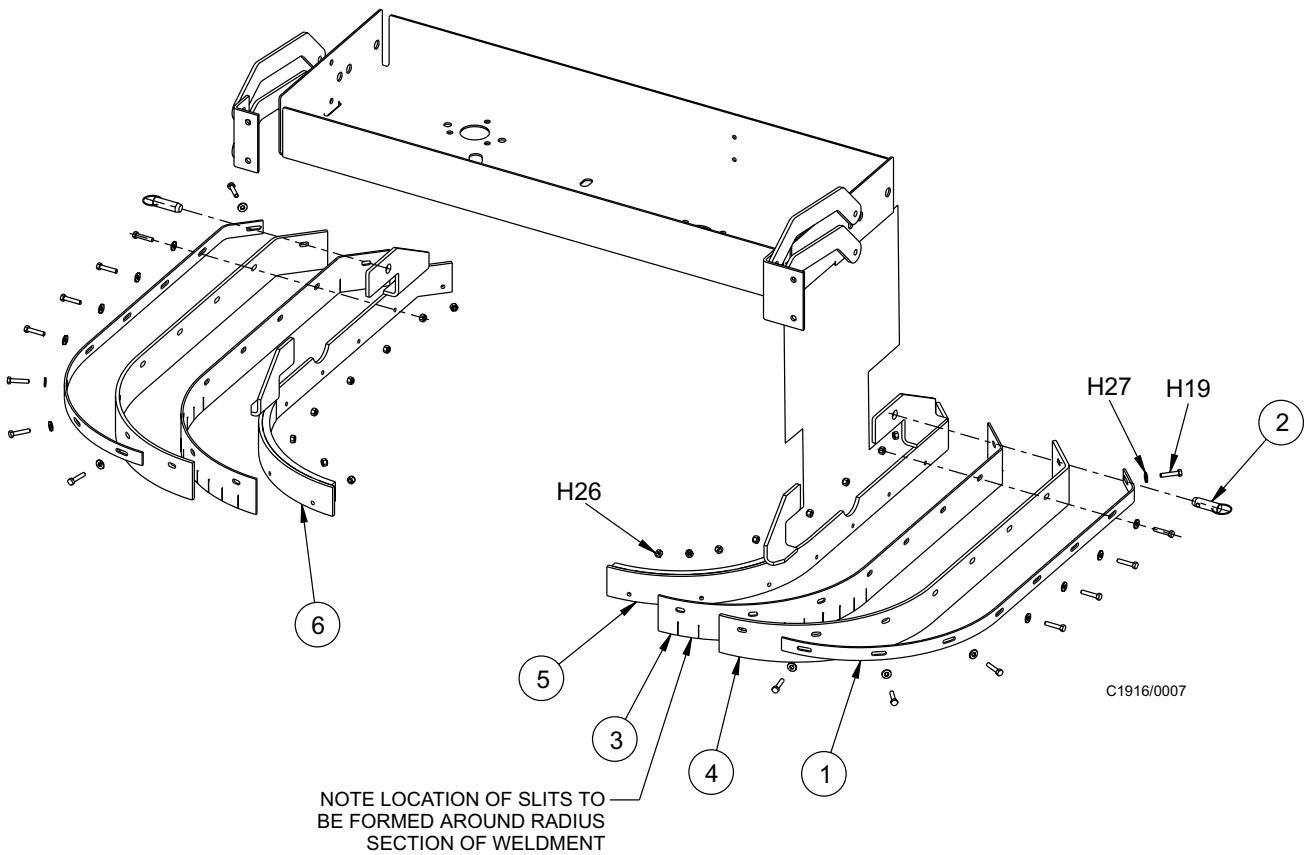

<u>Key No.</u>	<u>Part Number</u>	<u>Description</u>	<u>Qty.</u>
1	7-13-07209	Clamp, Side Squeegee	2
2	7-55-08151	Pin, Lock Up	2
3	7-77-00140	Rubber, Side Squeegee (inner)	2
4	7-77-00141	Rubber, Side Squeegee (outer)	2
5	7-86-08063	Tool, Side Squeegee (LH)	1
6	7-86-08062	Tool, Side Squeegee (RH)	1

## HARDWARE USED:

H19	2-00-02587	Screw, 1/4-20 x 1.250 HHC	16
H26	2-00-00641	Nut, 1/4-20 Insert Fiber	16
H27	2-00-03702	Washer, .625 x .281 x .063	16

C1916/0007

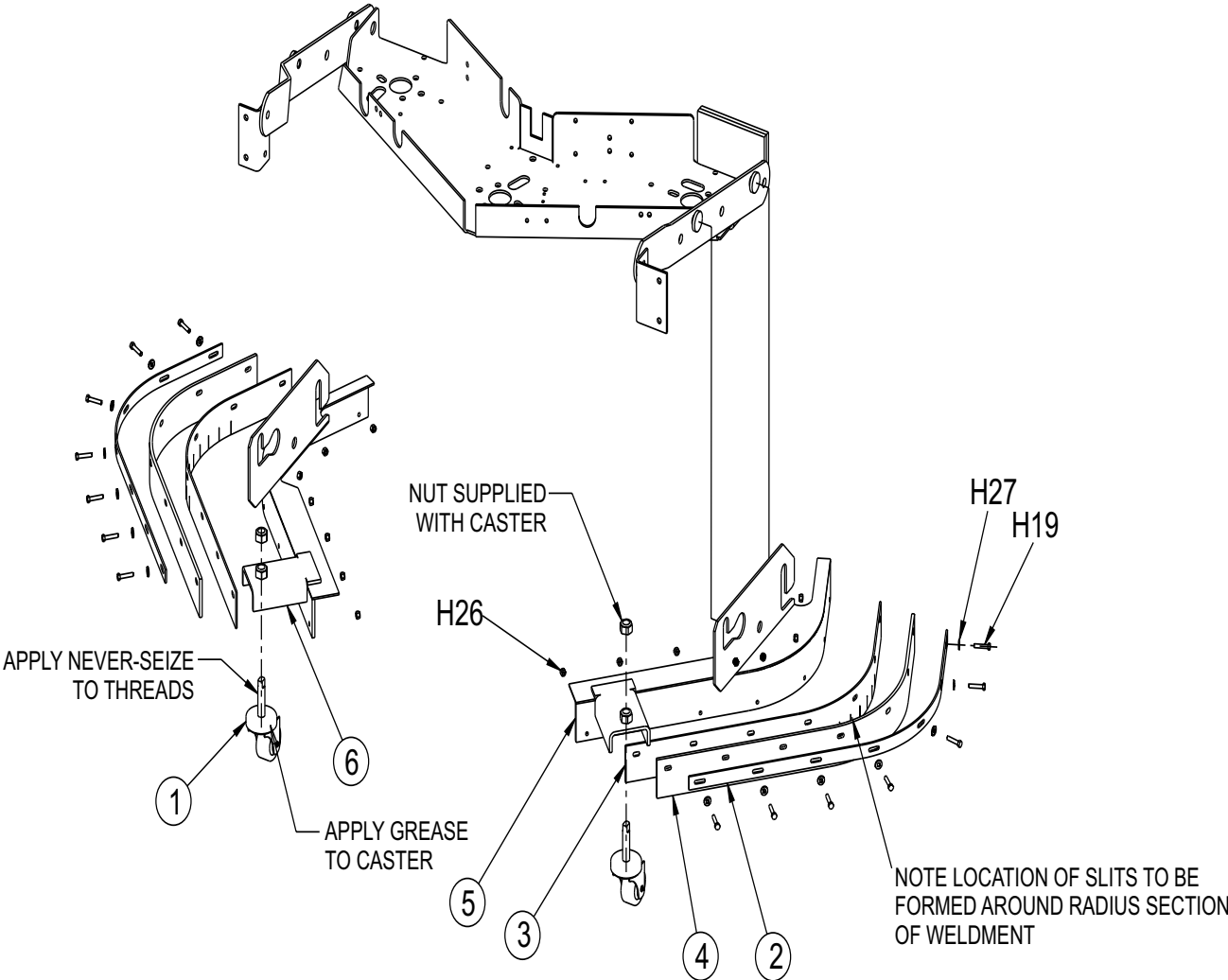

C1967/0006

<b>Key No.</b>	<b>Part Number</b>	<b>Description</b>	<b>Qty.</b>
1	7-89-08073	Caster	2
2	7-13-07210	Clamp - R.H. Side Squeegee (46")	2
3	7-77-00142	Rubber - Side SQG (Inner)	2
4	7-77-00143	Rubber - Side SQG. (Outer)	2
5	7-86-08066	Tool - Side Squeegee (LH)	1
6	7-86-08065	Tool - Side Squeegee (RH)	1

**HARDWARE USED:**

H19	2-00-02587	Screw, 1/4-20 x 1.250 HHC	14
H26	2-00-00641	Nut, Hex Fiber Insert 1/2-20	14
H27	2-00-03702	Washer, .625 x .281 x .063	14

C1967/0006

## **REAR SQUEEGEE (40") - PARTS LIST**

---

<b><u>Key No.</u></b>	<b><u>Part Number</u></b>	<b><u>Description</u></b>	<b><u>Qty.</u></b>
1	7-75-01164	Bushing, Spacer	2
2	7-89-08073	Caster	2
3	7-13-07188	Clamp, LH Squeegee End	1
4	7-13-07156	Clamp, Nut	2
5	7-13-07187	Clamp, RH Squeegee End	1
6	7-20-06010	Duct - Squeegee Inlet	1
7	7-39-00026	Knob, Squeegee	4
8	2-00-04962	O-Ring, Seal	2
9	7-77-00110	Squeegee, Rubber Inner	1
10	7-75-01188	Spacer - Squeegee	2
11	7-77-00109	Squeegee, Rubber Outer	1
12	7-86-08064	Squeegee Weldment (40 In)	1
13	7-79-00101	Strap, Squeegee Clamp	1
14	2-14-00184	Wheel	2

### **HARDWARE USED:**

H51	2-00-00216	Screw, 3/8-16 x 2.000 HHC	2
H52	2-00-00402	Flat Washer, .750 x .390 x .094	4
H54	2-00-02360	Nut, 3/8-16 Hex.	2
H259	2-00-05343	Bolt Carriage, .38-16 x 3.50 SST	2
H261	2-00-05344	Screw - HHM .313 - 18 x 1.75 STL	2
H283	2-00-03842	Roll Pin, 1/4 x 1.00	2

C1915/0007

# REAR SQUEEGEE (40") - EXPLODED VIEW

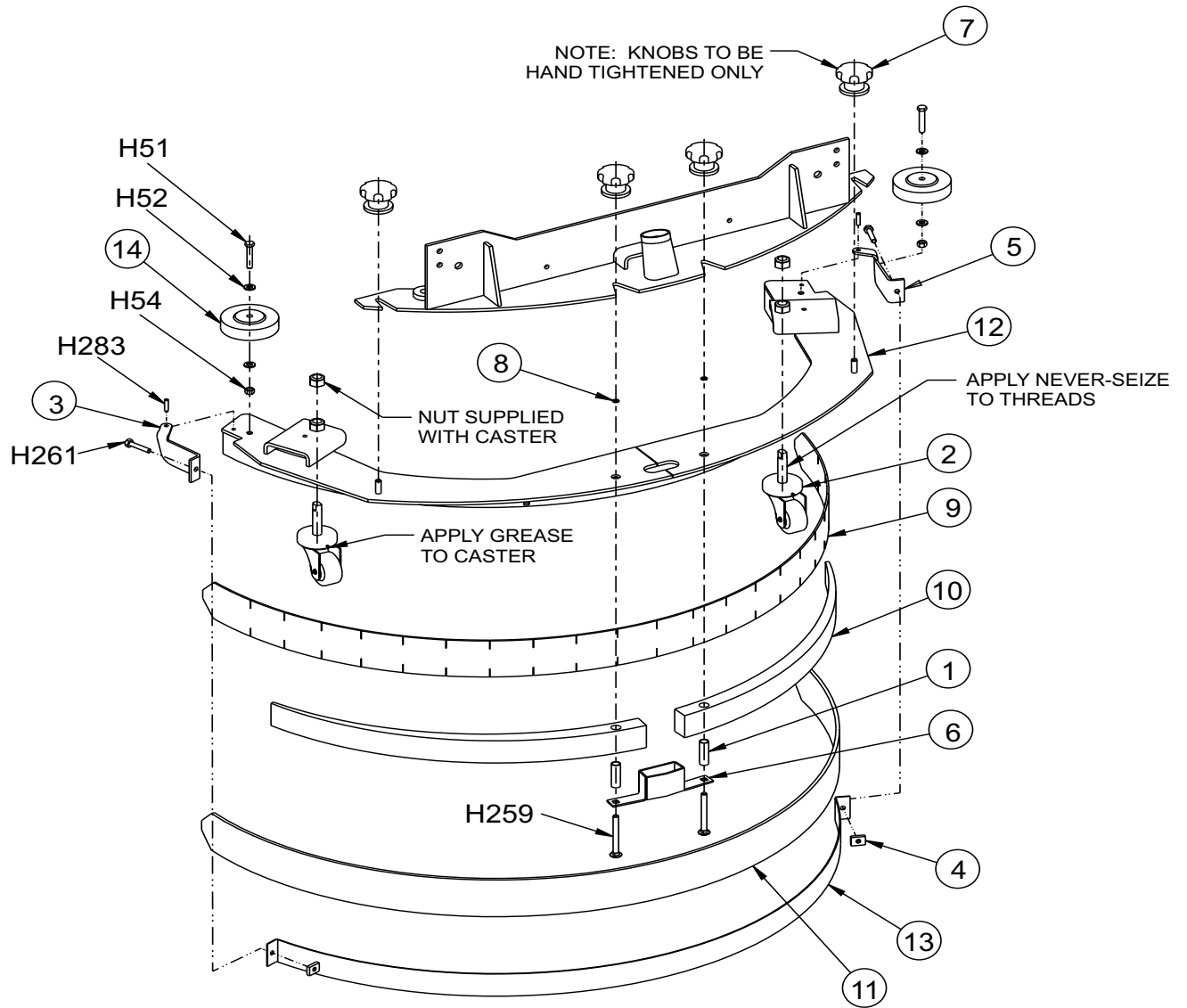

## **REAR SQUEEGEE (46") - PARTS LIST**

---

<b><u>Key No.</u></b>	<b><u>Part Number</u></b>	<b><u>Description</u></b>	<b><u>Qty.</u></b>
1	7-75-01164	Bushing - Spacer	2
2	7-89-08073	Caster	2
3	7-13-07157	Clamp - End Squeegee	2
4	7-13-07156	Clamp - Nut	2
5	7-20-06010	Duct - Squeegee Inlet	1
6	7-39-00026	Knob - Squeegee	4
7	2-00-04962	O-Ring	2
8	7-77-00110	Rubber - Squeegee, Inner	1
9	7-75-01169	Spacer - Squeegee	2
10	7-77-00109	Squeegee - Rubber - Outer	1
11	7-86-08038	Squeegee Weldment	1
12	7-79-00088	Strap - Squeegee Clamp	1
13	2-14-00184	Wheel	2

### **HARDWARE USED:**

H51	2-00-00216	Screw, 3/8-16 x 2.000 HHC	2
H52	2-00-00402	Flat Washer, .750 x .390 x .094	4
H54	2-00-02360	Nut, 3/8-16 Hex.	2
H259	2-00-05343	Bolt Carriage, .38-16 x 3.50 sstl.	2
H261	2-00-05344	Screw - HHM .313-18 x 1.75 Stl.	2

C1963/0007

**REAR SQUEEGEE (46") - EXPLODED VIEW**

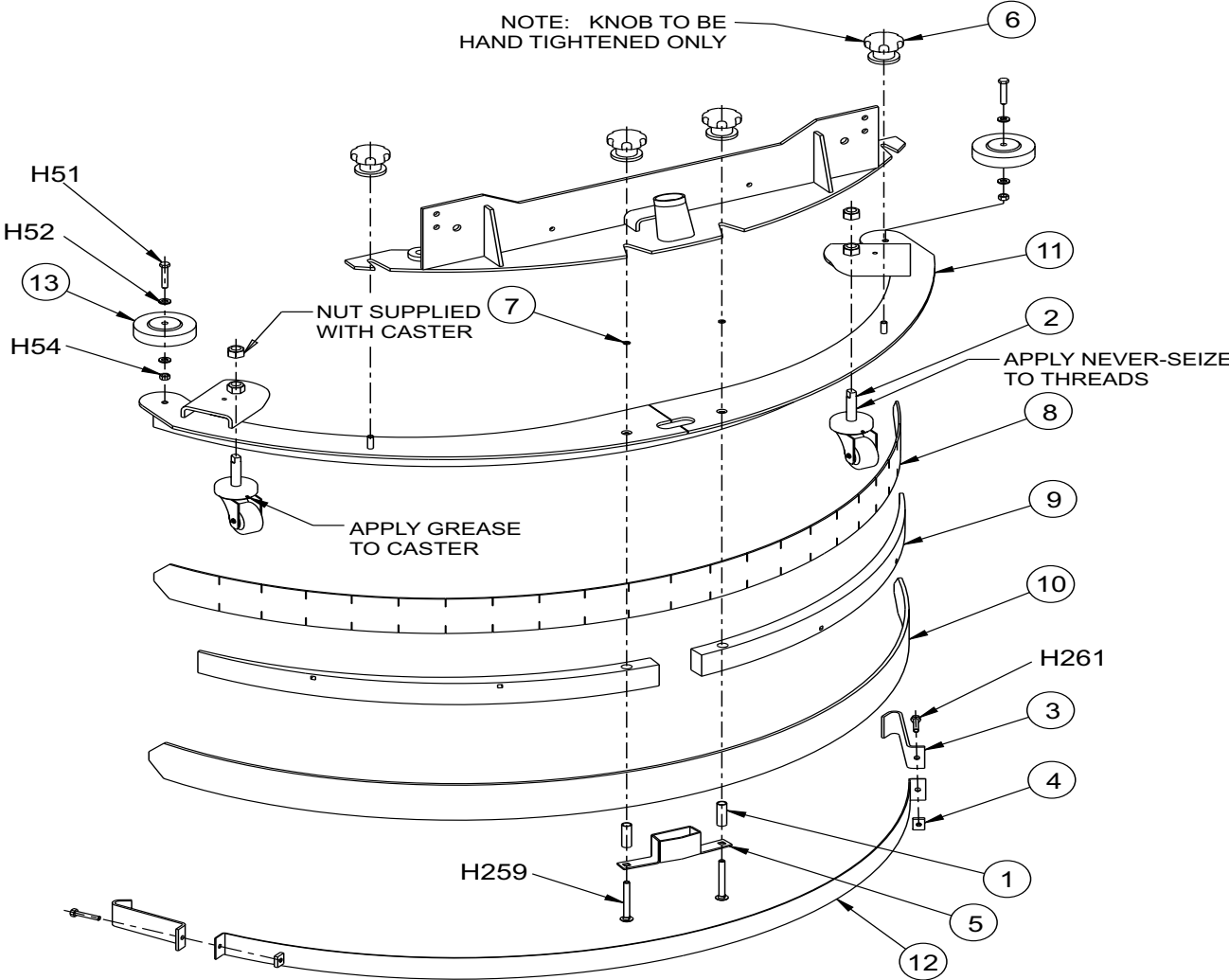

C1963/0007

## **REAR SQUEEGEE LIFT SYSTEM (12V & 36V) - PARTS LIST**

<u>Key No.</u>	<u>Part Number</u>	<u>Description</u>	<u>Qty.</u>
1	7-27-07203	Frame - Winch Mtg.	1
2	7-30-08021	Guide - Squeegee Lift Cable	1
3	0785-090	Worm Gear Assembly	1
4	0782-147	Motor - Electric (1/2 H.P., 36 VDC)	1
5	7-58-05300	Plate - Winch Side	1
6	7-16-05036	Coupling - Squeegee Lift	1
7	2-00-02241	Key - .188/.187 Sq. X 1 3/8 IG.	1
8	7-13-05449	Bearing - 5/8" Flanged	1
9	7-20-03003	Drum - Squeegee Winch	1
10	2-95-04182	Nut - 3/8-16 Elastic Stop Nut	2
11	8-10-00043	Cable - Side Broom (LH)	1
12	7-13-05076	Chain - Squeegee Lift	2
13	7-29-05044	Gear - Pinion	1
14	2-00-02240	Key - .188/.187 Sq. x .75 Lg.	1
15	7-08-01007	Bracket - Lift Adjustment	1
16	7-08-01011	Bracket - Switch Mtg.	1
17	2-00-05470	Nut - Barrel	1
18	7-70-05195	Shaft	1
19	2-00-03932	Ring - External Retaining for 3/8 Dia.	2
20	2-00-05469	Bearing - 3/8" Flanged	1
21	7-29-05045	Gear - Driven	1
22	7-82-00008	Switch	2
23	7-16-07434	Cover - Squeegee Lift	1
24	7-76-00122	Spring	1
25	2-00-01477	Roll Pin	1
26	2-00-05488	Setscrew - #10-32 x 5/16 lg, Flat Point	1

### **HARDWARE USED:**

H1	2-00-05060	Screw, #6-32 x 1.250 RHM	4
H3	2-00-01499	Lock Washer, #6 Med. Helical Spring	4
H15	2-00-00221	Screw, 1/4-20 x .750 HHC	11
H26	2-00-00641	Nut, 1/4-20 Insert Fiber	3
H27	2-00-03702	Washer, .625 x .281 x .063	2
H38	2-00-00225	Screw, 5/16-18 x 1.500 HHC	2
H43	2-00-00409	Flat Washer, .687 x .344 x .062	4
H45	2-00-00585	Nut, Hex. 5/16-18 x .500 x .265	2
H46	2-00-00644	Nut, 5/16-18, Insert Fiber	3
H52	2-00-00402	Flat Washer, .750 x .390 x .094	2
H72	2-00-00518	Lock Washer, Helical Spring	11
H86	2-00-03575	Bolt Carr., .25-20 x .75 GR 5 ZN	2
H131	2-00-03855	Carriage Bolt, 3/8-16 x 1.000	2
H237	2-00-05356	Screw, 5/16-18 x 1.25 Grade 8	1
H331	2-00-03042	Screw - HSHC, .25-20 x 1.50	1
H368	2-00-05029	Flatwasher 2.000 x .281 x .080	1
H369	2-00-00087	Screw - RHM 1/4-20 x 2 1/4	1

C1903/0103

**REAR SQUEEGEE LIFT SYSTEM (12V & 36V)- EXPLODED VIEW**

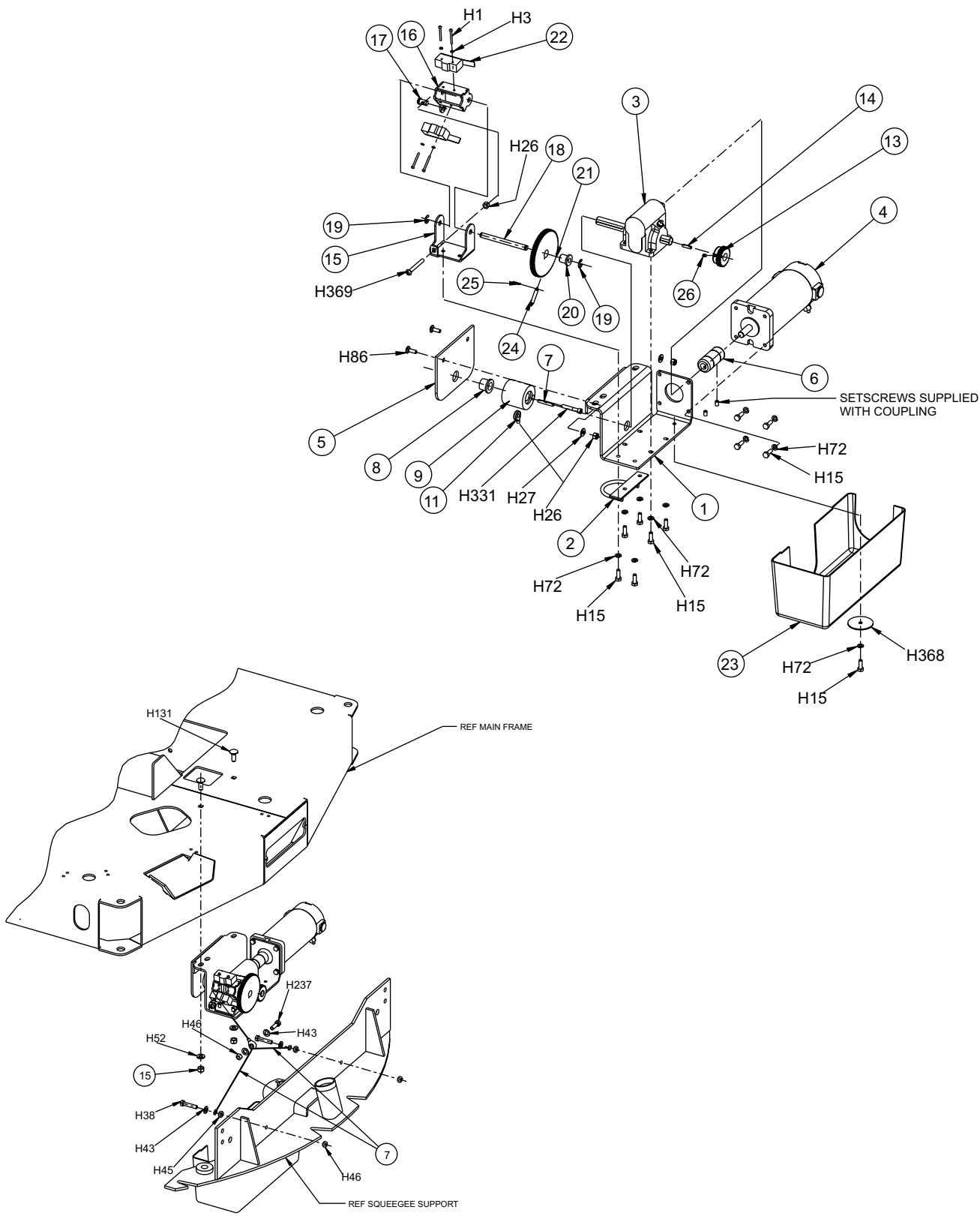

C1903/0103

## **SWING SQUEEGEE SUPPORT- PARTS LIST**

---

<b><u>Key No.</u></b>	<b><u>Part Number</u></b>	<b><u>Description</u></b>	<b><u>Qty.</u></b>
1	7-03-04211	Arm - Scrub Brush Frame	2
2	7-03-04210	Arm - Squeegee	2
3	7-08-00839	Bracket - Angle	2
4	7-09-01057	Bushing - Brush Lift	8
5	7-89-08073	Caster	1
6	8-15-01002	Collar - Setscrew	6
7	2-00-02216	Hose Clamp	1
8	2-95-04182	Nut - 3/8-16 Elastic Stop Nut	12
9	7-70-05194	Shaft	2
10	7-86-08067	Squeegee Support (Weldment)	1
11	7-81-00232	Support - Squeegee	2
12	7-55-08144	Weldment - Rear Pin Assy	2
13	7-08-00994	Weldment - Bracket Assy L.H.	1
14	7-08-00993	Weldment - Bracket Assy R.H.	1

### **HARDWARE USED:**

H46	2-00-00644	Nut, 5/16-18, Insert Fiber	8
H49	2-00-00209	Screw, 3/8-16 x 1.250 HHC	4
H50	2-00-00234	Screw, 3/8-16 x 1.500 HHC	8
H61	2-00-02616	Screw, 1/2-13 x 3.000 HHC	2
H68	2-00-00640	Nut, Hex Fiber Insert 1/2-20	4
H237	2-00-05356	Screw, 5/16-18 x 1.25 Grade 8	8

C1938/0007

# SWING SQUEEGEE SUPPORT - EXPLODED VIEW

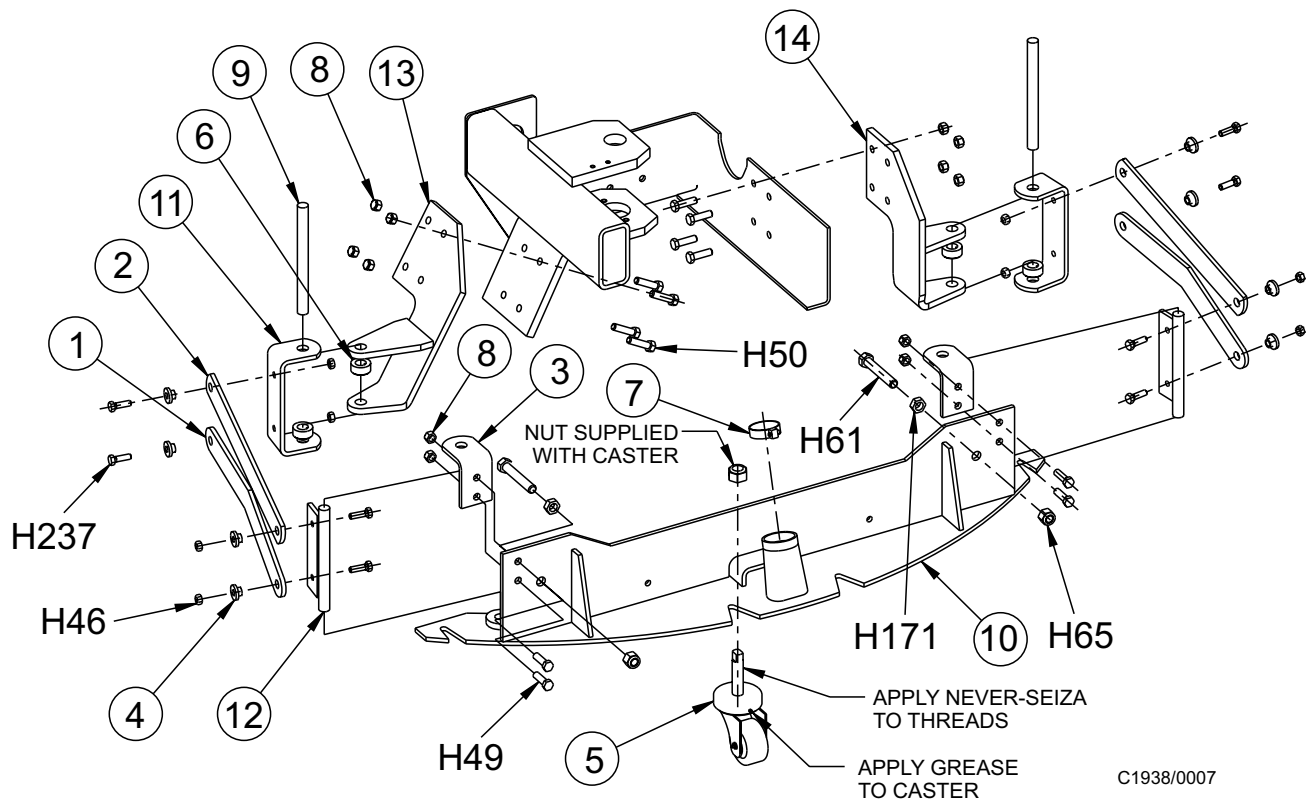

C1938/0007

## **SOLUTION TANK- PARTS LIST**

---

<b><u>Key No.</u></b>	<b><u>Part Number</u></b>	<b><u>Description</u></b>	<b><u>Qty.</u></b>
1	7-83-04190	Tank - Solution	1
2	7-24-04053	Filter, Solution	1
3	7-09-01122	Bushing	1
4	0775-217	Switch, Float Altered (NC)	1
5	7-87-02191	Tube, Float Switch	1
6	7-16-07420	Cover, Tank (Weldment)	1
7	7-29-00264	Gasket, Lid (Solution Tank)	1
8	7-56-05027	Fitting - Adapter (1"NPT x SLIP)	1
9	2-00-04620	Seal - O-Ring	1
10	7-33-02409	Hose, Drain	1
11	839401	Valve, Drain	1
12	833901	Handle, Drain Valve	1
13	7-29-00186	Gasket - Drain Valve	1
14	52206A	Chain, Cover Autoscrubber	1
15	962987	SCR 10 - 24 x 3/8 PN *ST Typ23	2
16	7-08-00986	Bracket - Tank Cover (Hinge) RT	1
17	7-08-00987	Bracket - Tank Cover (Hinge)LT	1
18	7-08-00981	Bracket, Solution Drain Hose	1
19	2-95-04689	Washer - Axle	4
20	7-31-06079	Handle - Cover	1
21	7-68-05022	Seal - Tank Lid	1
22	7-33-02440	Hose - solution Feed	1

### **HARDWARE USED:**

H8	2-00-00039	Screw, 10-24 x 1.000 RHM	4
H9	2-00-00426	Flat Washer, .500 x .219 x .063	4
H12	2-00-01246	Nut, Hex Fiber Insert #10-24	4
H15	2-00-00221	Screw, 1/4-20 x .750 HHC	2
H26	2-00-00641	Nut, 1/4-20 Insert Fiber	2
H47	2-00-00232	Screw, 3/8-16 x .750 HHC	4
H53	2-00-02310	Lock Washer, Helical Spring 3/8 Med.	4
H344	2-00-04578	Terminal Insulated Bullet Plu	2
H352	2-00-03404	Clamp - Witteck - C24P	2

C1920/0106

# SOLUTION TANK - EXPLODED VIEW

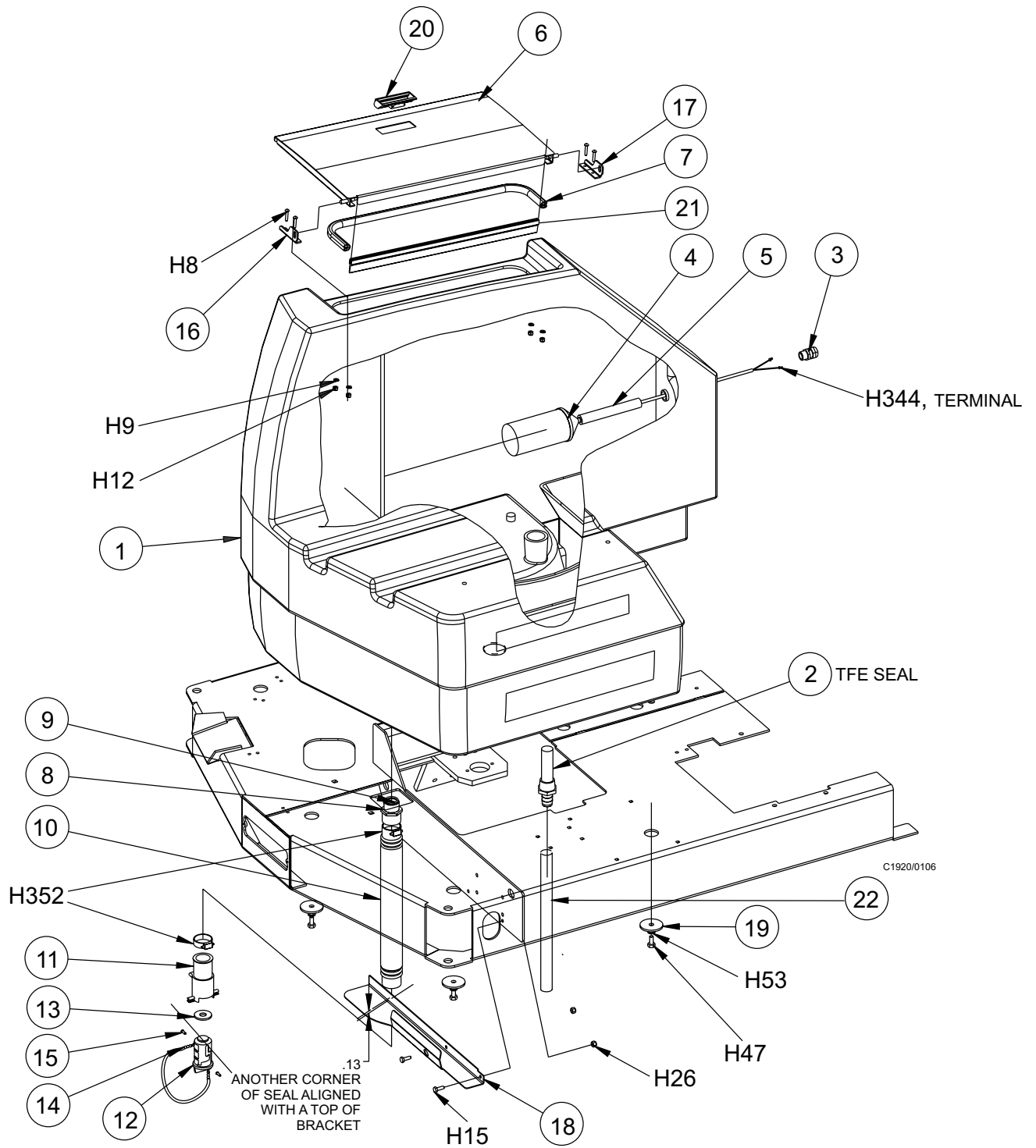

## **SOLUTION CONTROL- PARTS LIST**

---

<b><u>Key No.</u></b>	<b><u>Part Number</u></b>	<b><u>Description</u></b>	<b><u>Qty.</u></b>
1	7-88-00073	Valve - Solution (36VDC)	2
2	2-95-04182	Nut - 3/8-16 Elastic Stop Nut	1
3	2-00-04564	Clamp - Cable	1
4	7-08-00991	Brkt-Elbow	1
5	7-88-00079	Valve	1
6	7-41-05116	Lever-valve	1
7	7-57-05018	Wire Swivel	1
8	2-00-02000	Roll Pin	1
9	7-25-02053	90° Elbow (3/4 NPT to 3/4 Barb)	
10	7-25-02012	Fitting - 3/4 I.D. Hose Str. Barb	1
11	2-00-04250	Clamp	1
12	7-10-00034	Cable-Solution control	1
13	2-00-05253	Clamp	1
14	7-25-02012	Fitting - 3/4 I.D. Hose Str. Barb	1

### HARDWARE USED:

H7	2-00-00056	Screw, #10-24 x .750 RHM	1
H12	2-00-01246	Nut, Hex Fiber Insert #10-24	1
H17	2-00-00205	Screw, 1/4-20 x 1.000 HHC	2
H25	2-00-00594	Nut, Hex 1/4-20 x .437x.218	1
H26	2-00-00641	Nut, 1/4-20 Insert Fiber	3
H27	2-00-03702	Washer, .625x.218x.063	2
H189	2-00-00460	Flatwasher, .437 x .192 x .031-s	1
H345	2-00-00249	Screw - HHM 8-32 x .375 Brass/Chr	1

C1917/0012

**SOLUTION CONTROL - EXPLODED VIEW**

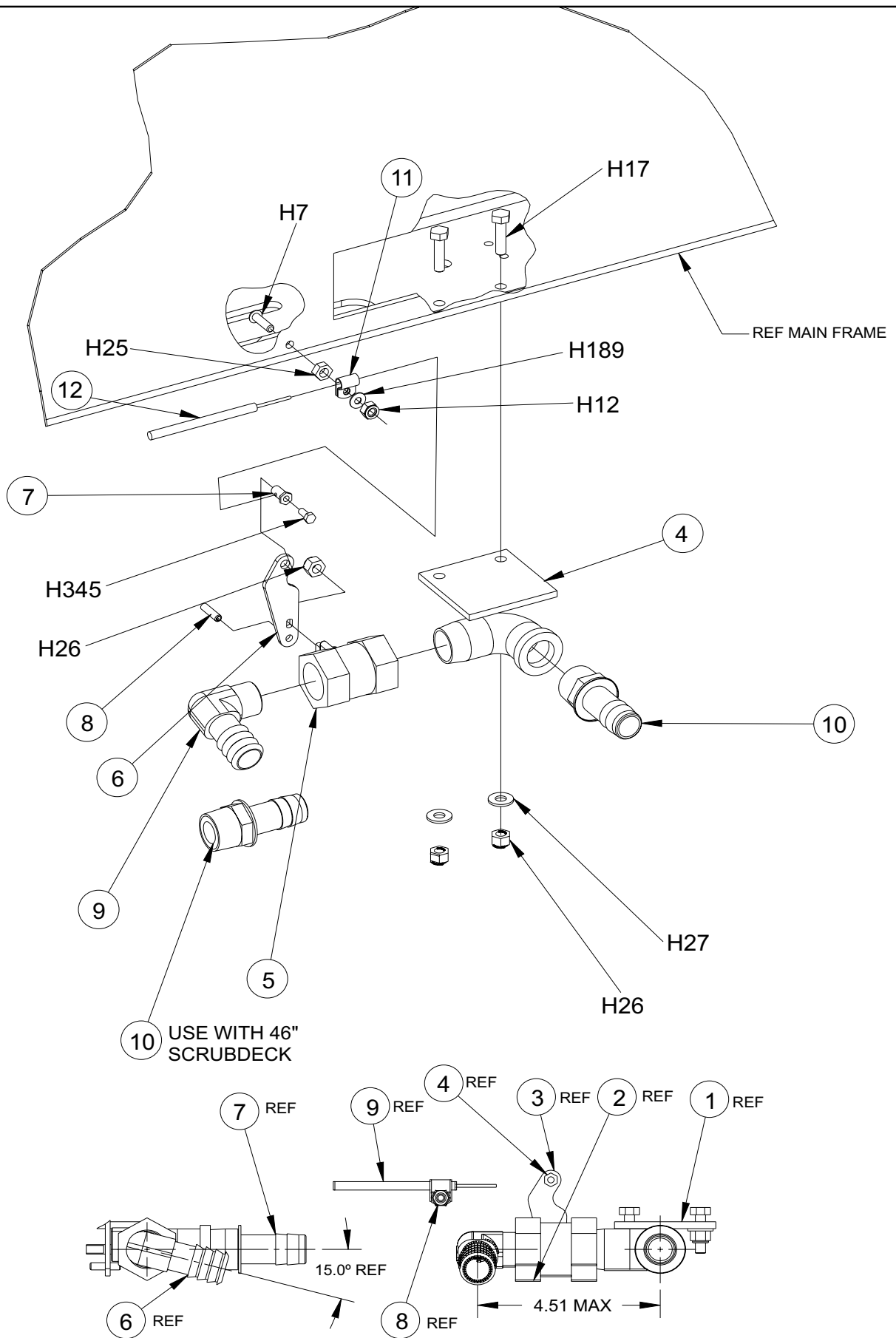

## **RECOVERY TANK- PARTS LIST**

---

<b><u>Key No.</u></b>	<b><u>Part Number</u></b>	<b><u>Description</u></b>	<b><u>Qty.</u></b>
1	7-83-04178-1	Tank, Recovery	1
2	7-58-05299	Plate, Vac Inlet (welded)	1
3	7-26-04012	Float, Recovery	1
4	7-10-04008	Float Cage	1
5	7-33-02427	Hose, Recovery Tank Inlet	1
6	2-00-02216	Hose Clamp	5
7	7-33-02397	Hose, Squeegee	1
8	7-87-02203	Tube - Vacuum Hose	1
9	7-33-02420	Hose - Lower Squeegee	1
10	0775-164	Float Switch (gray)	1
11	7-09-01122	Bushing	1
12	7-31-07027	Hanger, Drain Hose	1
13	7-80-05086	Stud, Clean out Door	2
14	7-29-00250	Gasket, Recovery Tank Drain	1
15	7-19-08063	Door, Recovery Tank Drain	1
16	25201A	Knob	2
17	7-33-02396	Hose, Drain	1
18	7-87-02201	Tube, Drain	1
19	7-33-02405	Hose, Drain	1
20	7-29-00265	Gasket, Vac Recovery	1
21	2-95-04689	Washer - Axle	3
22	2-14-03197	Washer - Neoprene, 1 x .19 x 1/8	4

### **HARDWARE USED:**

H24	2-00-00220	Screw, 1/4-20 x .625 HHC	2
H29	2-00-04966	Screw, 1/4-20 x 1.500 HHM	2
H30	2-00-04687	Lock Washer, Helical Spring 1/4 Med.	2
H32	2-00-04688	Nut, 1/4-20 Hex.	2
H47	2-00-00232	Screw, 3/8-16 x .750 HHC	3
H53	2-00-02310	Lock Washer, Helical Spring 3/8 Med.	3
H72	2-00-00518	Lock Washer, Helical Spring	2
H94	2-00-00410	Flatwasher, .875 x .375 x .060	2
H126	2-00-03466	Screw, #10-16 x .500	8
H136	2-00-03940	Screw, #10-24 x .500 T/C HH	4
H230	2-00-00466	Flat Washer, .625 x .203 x .031	4
H346	2-00-05237	Washer - Flat .063 x .265 x .063	4

C1919/0106

**RECOVERY TANK - EXPLODED VIEW**

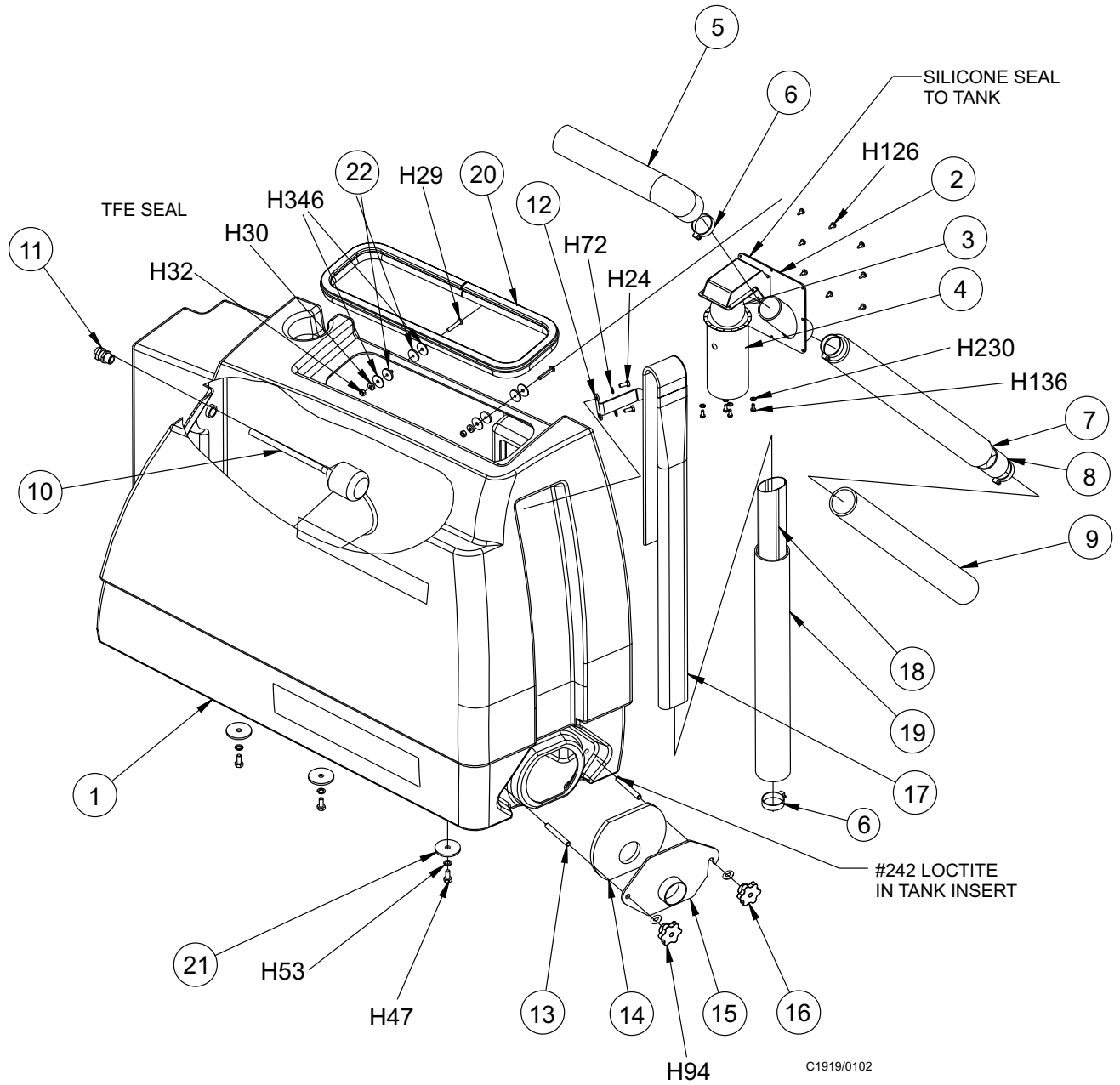

**FWD/REV CONTROLS - PARTS LIST**

---

<b>Key No.</b>	<b>Part Number</b>	<b>Description</b>	<b>Qty.</b>
1	7-30-05108	Guard - Upper Belt	1
2	7-03-04201	Arm - Weldment - Pump Control	1
3	2-00-00729	Key 1/8 x 5/8 (#5) Woodreff	1
4	8-16-00063	Centering Control	1
5	7-25-02050	Rod End, Spherco	2
6	8-66-00162	Rod - Brake Pull	1
7	2-95-01999	Nut, 1/4-28 Hex Jam	3
8	2-00-05261	Threaded Insert - 1/4-20	3
9	7-58-05303	Weldment - Foot Plate	1
10	7-55-00030	Pedal, FWD/REV	1
11	7-66-00197	1/4-20 Male Rod End	1
12	7-66-00194	Rod-Hydro Back	1
13	7-09-00148	Bushing - Flanged P/M Bushing	2
14	7-09-00149	Bushing	2
15	7-76-00123	Spring	2
16	7-82-00045	Switch - Proximity (Normally Open)	2

**HARDWARE USED:**

H15	2-00-00221	Screw, 1/4-20 x .750 HHC	3
H24	2-00-00220	Screw, 1/4-20 x .625 HHC	2
H26	2-00-00641	Nut, 1/4-20 Insert Fiber	1
H72	2-00-00518	Lock Washer, Helical Spring	3
H114	2-00-00633	Nut, Fiber 1/4-28	2
H233	2-00-02638	Screw, HHC .25-20 x 3.00	1
H319	2-00-02352	Nut, Hex Hvy. .50-13 stl-zn	1

C1923/0102

FWD/REV CONTROLS - EXPLODED VIEW

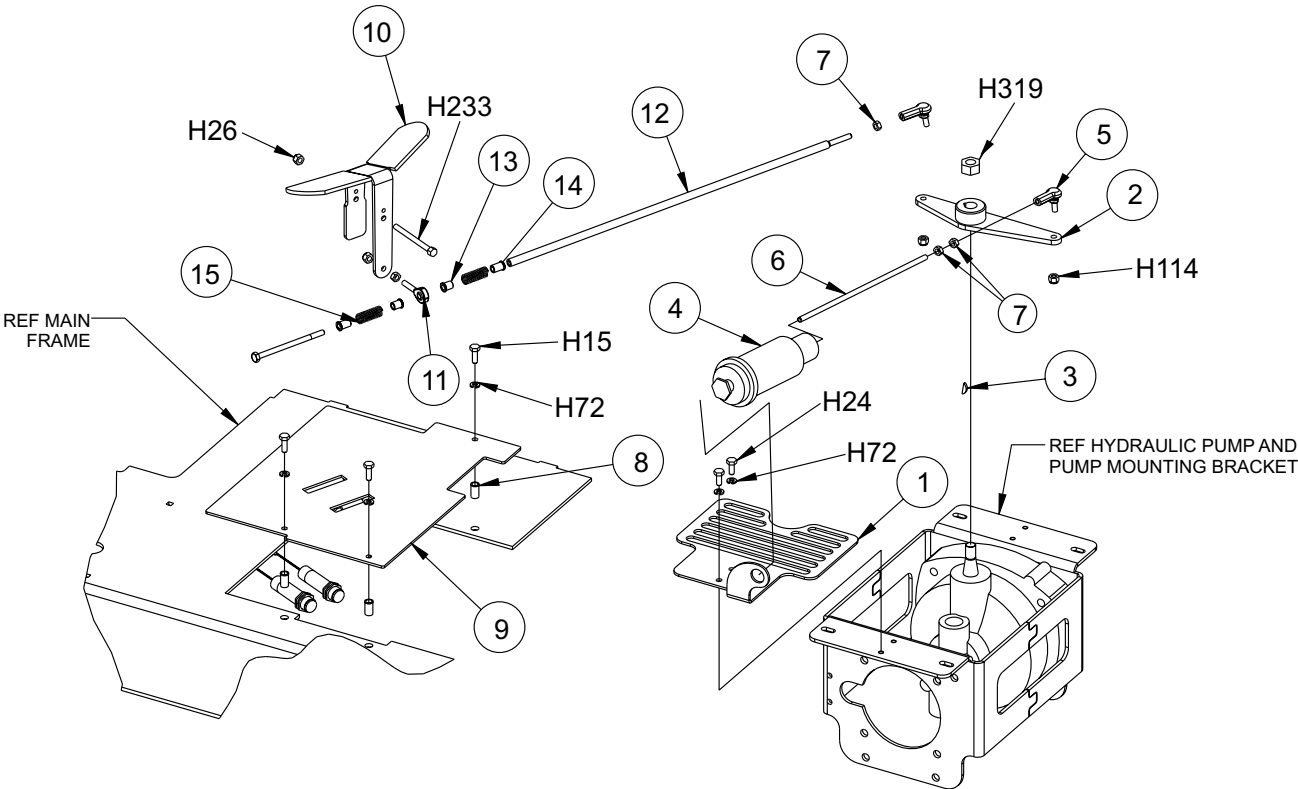

**BRAKE ASSEMBLY - PARTS LIST**

---

<u>Key No.</u>	<u>Part Number</u>	<u>Description</u>	<u>Qty.</u>
1	7-55-00029	Brake Pedal Weldment	1
2	7-55-00019-1	Arm - Parking Brake Pedal	1
3	8-09-01069	Bushing - Brake Pedal Lock	1
4	7-76-00013	Spring - Squeegee Release Pedal	1
5	2-00-03635	Pin - Roll	1
6	7-50-05145	Pad - Brake Pedal	1
7	8-13-07067	Clip - Parking Brake	1
8	7-08-02008	Brake Caliper Weldment	2
9	8-14-01006	Clevis	4
10	7-66-00192	Rod - Brake Link	2
11	2-00-04909	Yoke Pin Assembly	4
12	2-00-05249	Hair Pin (Cotter)	4
13	7-76-00051	Spring	2
14	2-95-01999	Nut - 1/4-28 Hex Jam	2

**HARDWARE USED:**

H17	2-00-00205	Screw, 1/4-20 x 1.000 HHC	4
H20	2-00-00203	Screw, 1/4-20 x 1.500 HHC	1
H26	2-00-00641	Nut, 1/4-20 Insert Fiber	5
H27	2-00-03702	Washer, .625 x .281 x .063	5
H45	2-00-00585	Nut, Hex. 5/16-18 x .500 x .265	2
H46	2-00-00644	Nut, 5/16-18, Insert Stop	4
H69	2-00-01255	Screw, 5/16-18 x .875 HHC Stl	4
H190	2-00-00529	Lock Washer - helical sps, 8 MDM	2

C1930/0007

**BRAKE ASSEMBLY - EXPLODED VIEW**

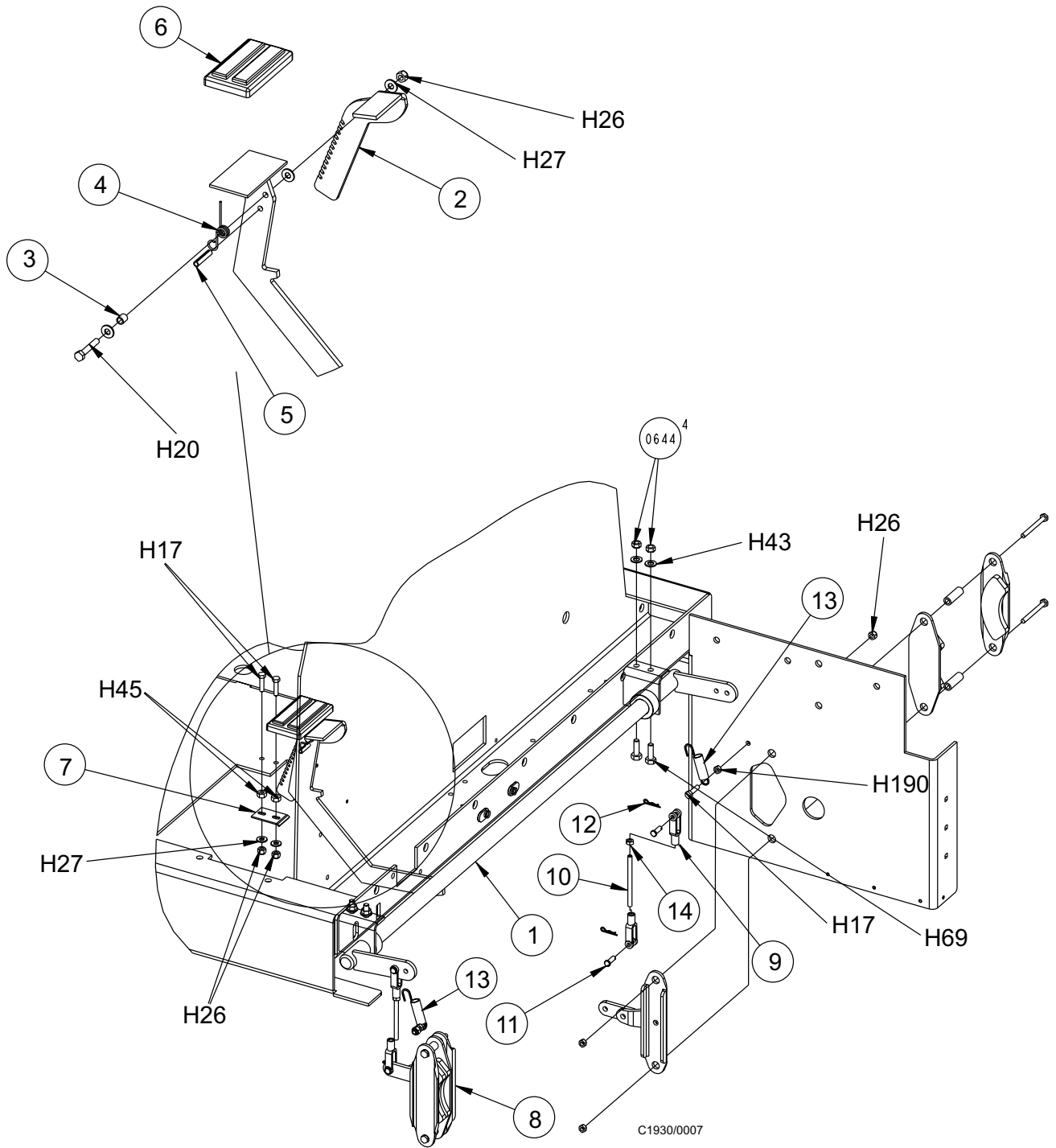

C1930/0007

## ***FRONT WHEEL ASSEMBLY - PARTS LIST***

---

<b><u>Key No.</u></b>	<b><u>Part Number</u></b>	<b><u>Description</u></b>	<b><u>Qty.</u></b>
1	2-00-03797	Axle Spacer Washer	2
2	7-03-09014	Axle - Front Wheels	1
3	7-08-02007	Brake Disc	2
4	2-00-04621	BRG - Outer Race (Cup Only)	4
5	2-00-00776	Cotter Pin (1/8 DIA. x 1-1/2 LG)	2
6	7-89-08044	Front Wheel (Molded) 16 in. dia.	4
7	8-11-00030	Dust Cap	2
8	7-33-09027	Hub - Front Wheel	2
9	8-23-03056	Nut - Special	2
10	8-23-03065	Nut - Wheel	10
11	2-00-02079	Roller Bearing	4
12	8-79-00030	Static Strap	1
13	8-80-05036	Stud	10
14	8-75-01136	Washer - Thrust	2

### **HARDWARE USED:**

H16	2-00-03051	Screw, 1/4-20 x .750 HSHC	10
H46	2-00-00644	Nut, 5/16-18, Insert Fiber	2
H84	2-00-00228	Screw, 5/16-18 x 2.250 HHC	2
H120	2-00-03829	Lock Washer, 3/8 Bolt	2
H149	2-00-01803	Washer, 1.063 x .031 x .063	3

C1902/0008

# FRONT WHEEL ASSEMBLY - EXPLODED VIEW

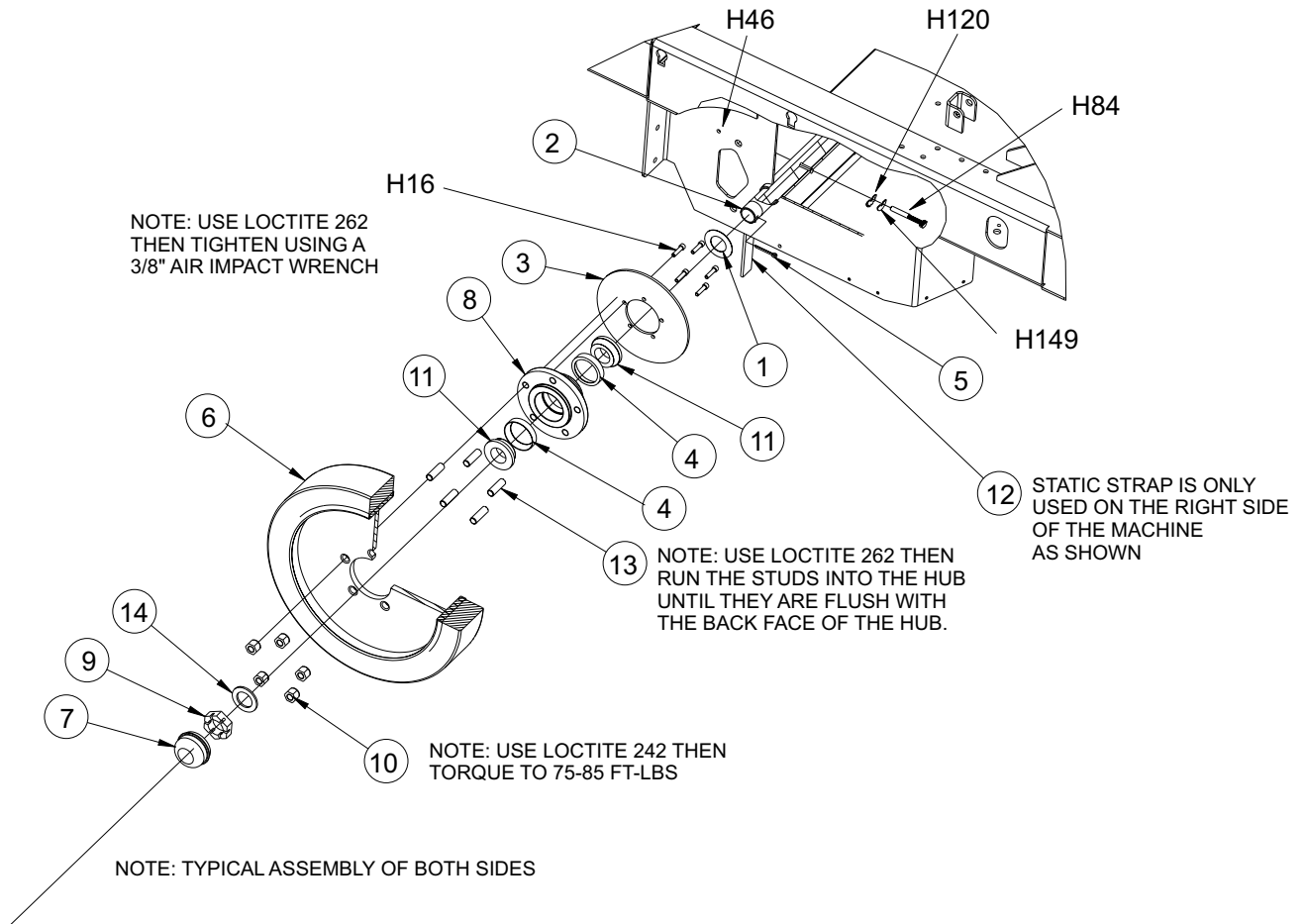

C1902/0008

## **REAR WHEEL ASSEMBLY - PARTS LIST**

---

<b><u>Key No.</u></b>	<b><u>Part Number</u></b>	<b><u>Description</u></b>	<b><u>Qty.</u></b>
1	7-30-08015	Guide - Rack	1
2	8-75-01163	Spacer	3
3	7-17-05010-1	Cylinder - Power Steering	1
4	7-62-00006	Rack	1
5	2-00-02079	Roller Bearing	2
6	2-00-04621	BRG - Outer Race (Cup Only)	2
7	7-81-00212	Support - Wheel	1
8	8-75-01136	Washer - Thrust	2
9	2-00-05024	Washer - Flat	1
10	2-00-05026	Nut (Slotted Head)	1
11	8-55-08131	Pin - Pivot (Rear Wheel)	1
12	7-13-07176	Clamp - Pivot Pin	1
13	2-00-02436	Pin - Cotter (Ø.18)	1
14	2-00-02557	Grease Fitting - 1/8 PTF x 90°	1
15	7-75-01182	Spacer Motor	2
*16	0885-094	Hydraulic Motor	Ref.
17	7-33-09028	Hub - Rear Wheel	1
18	0797-049	Wheel Assy - Wet Traction (4.0 Wide)	1
19	7-23-03101	Nut - Lug	5
*20	2-00-00566	Grease Zerk	1
*21	2-00-04892	Fitting - 90° Elbow (O-Ring)	Ref.
*22	2-00-04974	Fitting - #8 ORS to #10 SAE Connector	Ref.
23	2-00-00776	Cotter Pin (1/8 Dia. x 1-1/2 Lg.)	1

\*Items are part of Hyd Kit #0760-546

### **HARDWARE USED:**

H34	2-00-00208	Screw, 5/16 - 18 x .750 HHC	2
H35	2-00-02708	Screw, 5/16 - 18 x 1.000 HHM	3
H44	2-00-00530	Lock Washer, 5/16 HS Med.	5
H61	2-00-02616	Screw, 1/2-13 x 3.000 HHC	4
H65	2-00-04936	Nut, 1/2-13 Fibre Lock	4
H70	2-00-05354	Screw, 3/4-10 x 2.250 HHC	1
H109	2-00-00522	Lock Washer, 3/4 Helical Spring	1
H221	2-00-03335	Screw, Hex SOC Cap, .312 - 18 x .50	2
H243	2-00-00591	Nut, Hex-Jam .50-20	1
H312	2-00-05227	Screw, HHC M14 x 1.50 x 45mm gr10	5

C1901/0008

# REAR WHEEL ASSEMBLY - EXPLODED VIEW

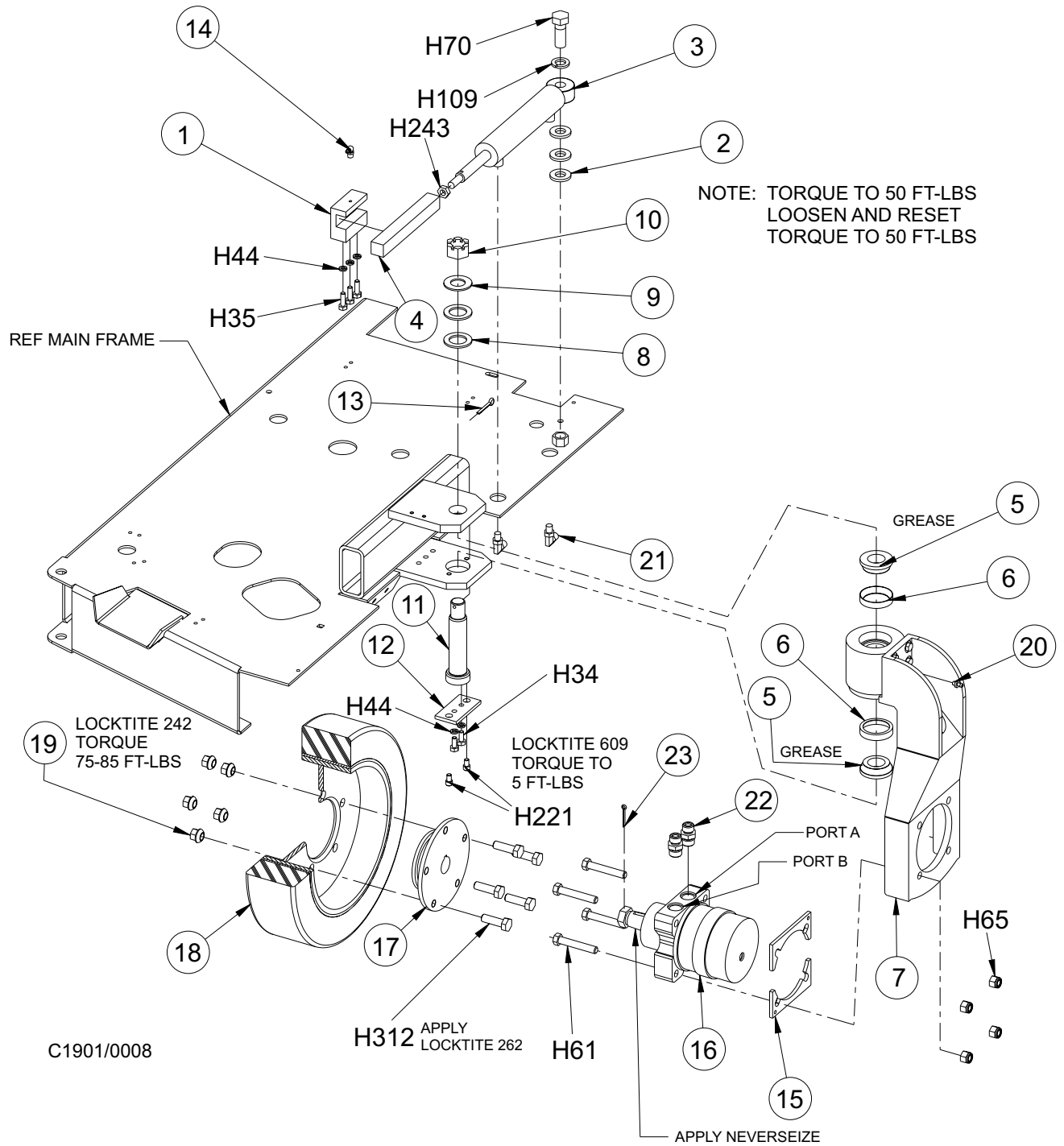

## **FRONT COVER AND LATCH ASSEMBLY - PARTS LIST**

---

<b><u>Key No.</u></b>	<b><u>Part Number</u></b>	<b><u>Description</u></b>	<b><u>Qty.</u></b>
1	7-09-01057	Bushing - Brush Lift	2
2	7-16-07400-1	Cover - Hopper/Battery	1
3	7-18-08003	Detent - Cover Pivot	2
4	7-31-06078	Handle - Cover Latch	1
5	7-41-00044	Latch - Hood	1
6	2-00-03635	Pin - Roll	1
7	7-57-05060	Pivot - Cover (LH)	1
8	7-57-05059	Pivot - Cover (RH)	1
9	7-58-05293	Plate - Light Plate	2
10	7-75-01205	Spacer - Latch	2
11	7-76-00120	Spring - Compression	2

### **HARDWARE USED:**

H10	2-00-00519	Lockwasher, #10 Med HS	2
H26	2-00-00641	Nut, 1/4-20 Insert Fiber	4
H34	2-00-00208	Screw, 5/16-18 x .750 HHC	8
H43	2-00-00409	Flat Washer, .687 x .344 x .062	10
H44	2-00-00530	Lock Washer, 5/16 HS Med.	8
H46	2-00-00644	Nut, 5/16-18, Insert Fiber	4
H54	2-00-02360	Nut, 3/8-16 Hex.	4
H268	2-00-00051	Screw - RH, .25-20 x .75	4
H342	2-00-05444	#10-24 BHCS 1.00 Black Oxide	2
H343	2-00-03994	Carriage Bolt .31-18 x 1.50	4

C1954/0012

**FRONT COVER AND LATCH ASSEMBLY - EXPLODED VIEW**

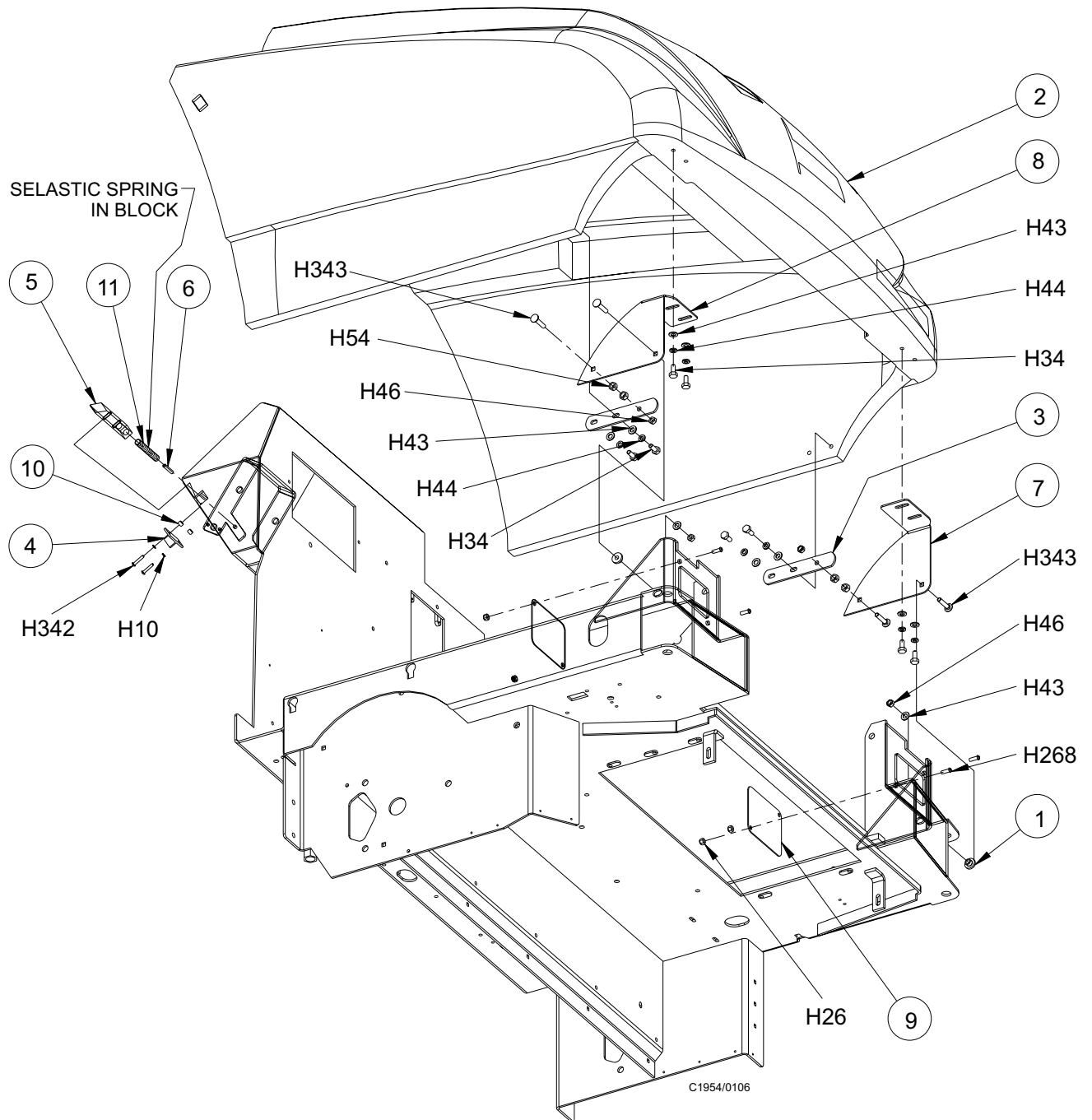

# SEAT ASSEMBLY

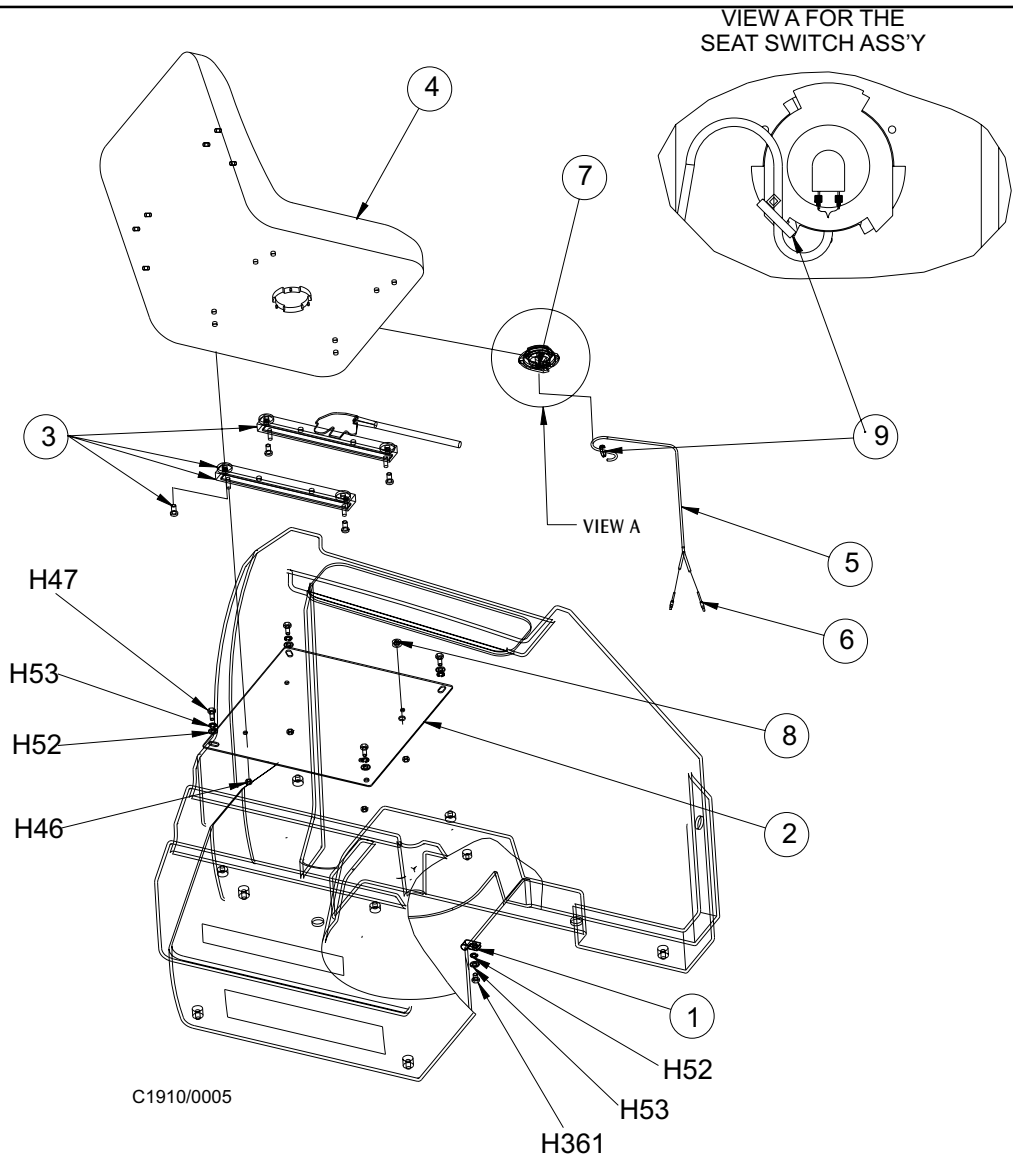

<u>Key No.</u>	<u>Part Number</u>	<u>Description</u>	<u>Qty.</u>
1	2-00-04873	Cable Clamp	1
2	7-58-05297	Plate, Seat MTG.	1
3	7-72-05005	Seat Adjuster Kit	1
4	7-69-00006	Seat	1
5	0875-126	Wire, Harness	1
6	2-00-04578	Terminal (.156)	2
7	8-82-00064	Switch, Seat	1
8	2-00-00491	Grommet	1
9	2-00-04345	Tye Rap	1

**HARDWARE USED:**

H46	2-00-00644	Nut, 5/16 - 18 Insert Fiber	4
H47	2-00-00232	Screw, 3/8 - 16 x .750 HHC	4
H52	2-00-00402	Flat Washer, .750 x .390 x .094	5
H53	2-00-02310	Lock Washer, Helical Spring 3/8 Med.	5
H361	2-00-00231	Screw - HHC - .375-16 x .63	1

C1910/0006

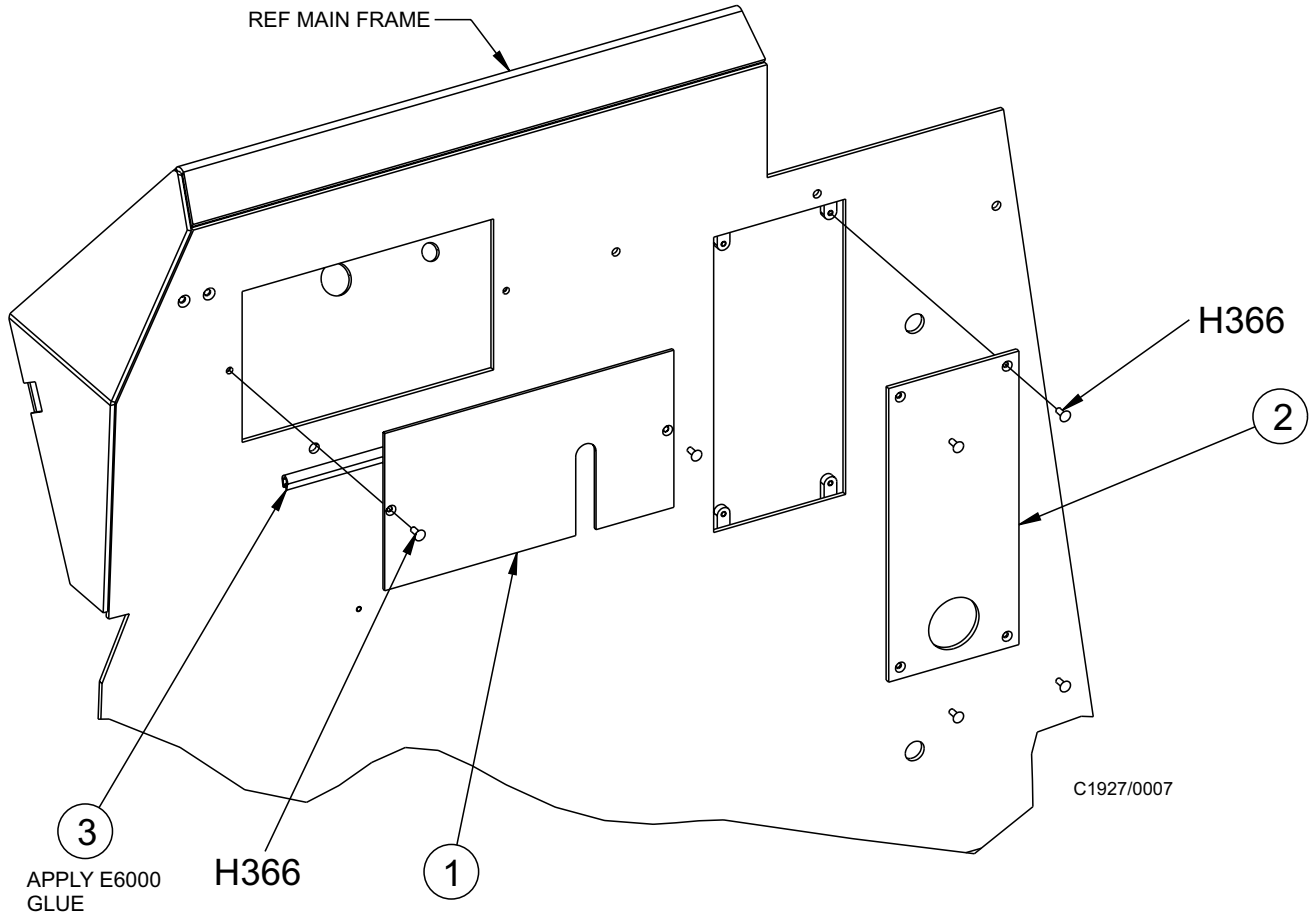

<u>Key No.</u>	<u>Part Number</u>	<u>Description</u>	<u>Qty.</u>
1	7-16-07421	Cover - Steering Access	1
2	7-16-07433	Cover - Harness Access	1
3	7-21-04044	Edging - Access Panel	1

**HARDWARE USED:**

H366	2-00-00011	Screw, #10-24 x .500 FHM, Zn.	6
------	------------	-------------------------------	---

C1927/0007

## **ROLLOUT BATTERY - PARTS LIST**

---

<b><u>Key No.</u></b>	<b><u>Part Number</u></b>	<b><u>Description</u></b>	<b><u>Qty.</u></b>
1	7-05-07179	Bar - Battery	1
2	2-00-03306	Bearing - Ball	16
3	7-08-00980	Brkt - Filter MTG	Ref.
4	7-08-00978	Brkt - Front Mtr Mtg	Ref.
5	7-08-00977	Brkt - Rear Mtr Mtg	Ref.
6	2-95-04182	Nut - 3/8-16 Elastic Stop Nut	4
7	7-51-05017	Pan - Battery	1
8	7-57-05063	Pivot - Battery Bar	1
9	7-75-01199	Spacer - Battery Stop (510 A.H.)	1
10	7-78-05029	Stop - Battery (720 A.H.)	1
11	7-81-00224	Support - Battery	Ref.

### **HARDWARE USED:**

H35	2-00-02708	Screw, 5/16-18 x 1.000 HHM	2
H46	2-00-00644	Nut, 5/16-18, Insert Fiber	2
H48	2-00-00233	Screw, 3/8-16 x 1.000 HHC	4
H58	2-00-00241	Screw, 1/2-13 x 1.750 HHC	3
H62	2-00-00405	Flat Washer, 1.063 x .531 x .094	9
H65	2-00-04936	Nut, 1/2-13 Fiber Lock	5
H148	2-00-01778	Screw, 1/2-13 x 2.000 HHC	1
H213	2-00-01254	Screw, 1/2-13 x 1.500 HHCS	1

C1929/0012

# ROLLOUT BATTERY - EXPLODED VIEW

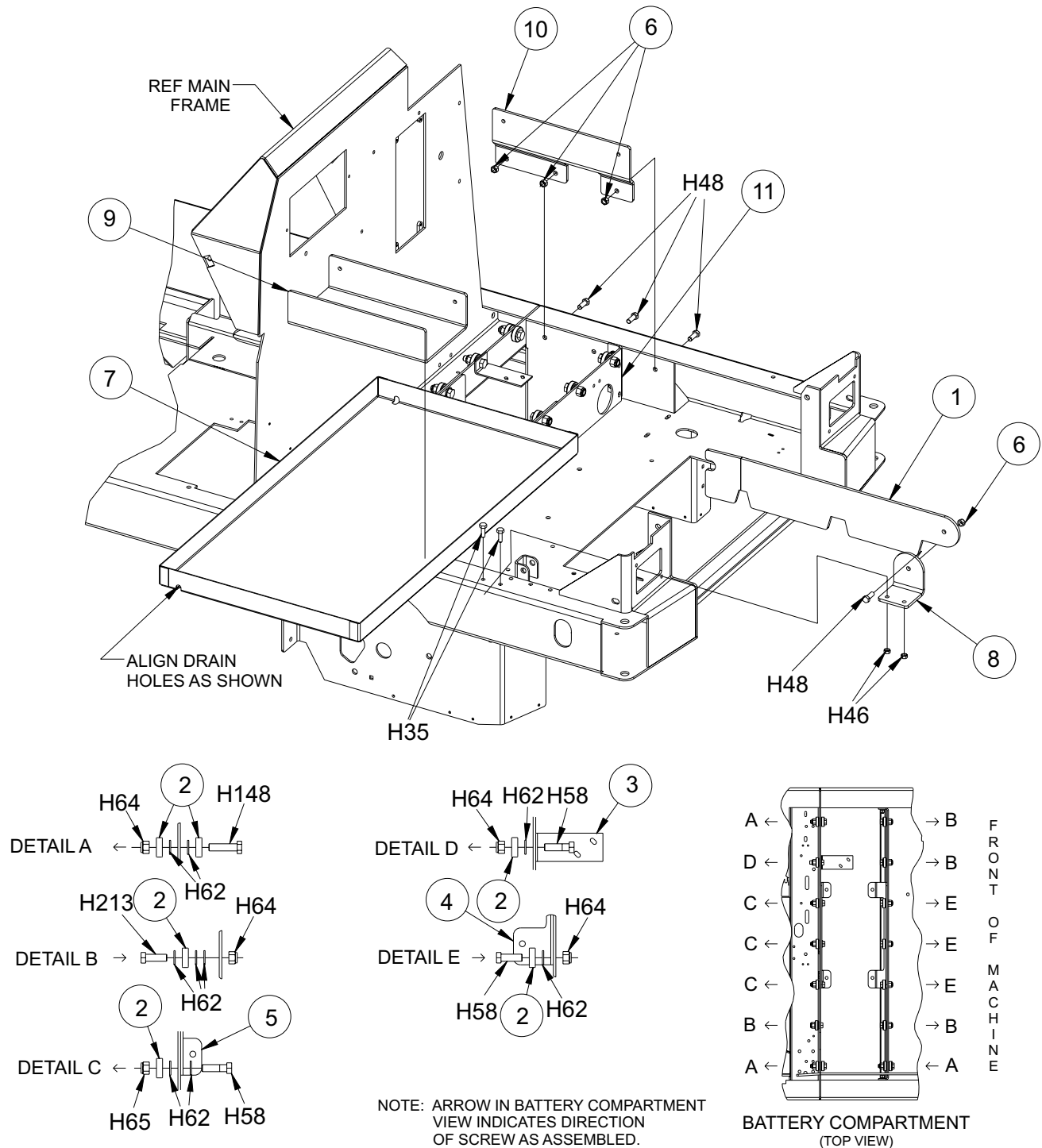

C1929/0012

## **DUST CONTROL - PARTS LIST**

---

<b><u>Key No.</u></b>	<b><u>Part Number</u></b>	<b><u>Description</u></b>	<b><u>Qty.</u></b>
1	8-48-00019	Weldment - Manifold, Impeller	1
2	8-08-00796	Bracket - Impeller Motor and Guard	1
3	0882-062	Motor - Impeller	1
4	8-23-00013	Impeller	1
5	2-00-00263	Set-Screw, HS Knurled Cup PT. #10-24 x 3/8	2
6	8-55-08114	Pin - Shaker Pivot	1
7	8-15-01016	Collar	4
8	7-58-05278	Plate - Shaker Motor	1
9	7-03-04135	Arm - Shaker	1
10	8-16-07406	Cover - Shaker Motor	1
11	0860-624	Motor - Filter Shaker (36V)	1
12	8-89-04019	Weight - Filter Shaker	1
13	2-00-00264	Set-Screw, HS Knurled Cup Pt. 1/4 - 20 x 5.16	1
14	8-29-00228	Gasket	2
15	8-29-00229	Gasket	2
16	7-81-00219	Support, Pivot IMP. Manifold	8

### **HARDWARE USED:**

H15	2-00-00221	Screw, 1/4-20 x .750 HHC	4
H26	2-00-00641	Nut, 1/4-20 Insert Fiber	6
H27	2-00-03702	Washer, .625 x .281 x .063	2
H35	2-00-02708	Screw, 5/16-18 x 1.000 HHM	2
H43	2-00-00409	Flat Washer, .687 x .344 x .062	2
H46	2-00-00644	Nut, 5/16-18, Insert Fiber	4
H72	2-00-00518	Lock Washer, Helical Spring	4
H86	2-00-03575	Carriage Bolt, 1/4-20 x .750	6
H151	2-00-00213	Screw, 5/16-18 x .625 HHC	4

C1935/0006

# DUST CONTROL- EXPLODED VIEW

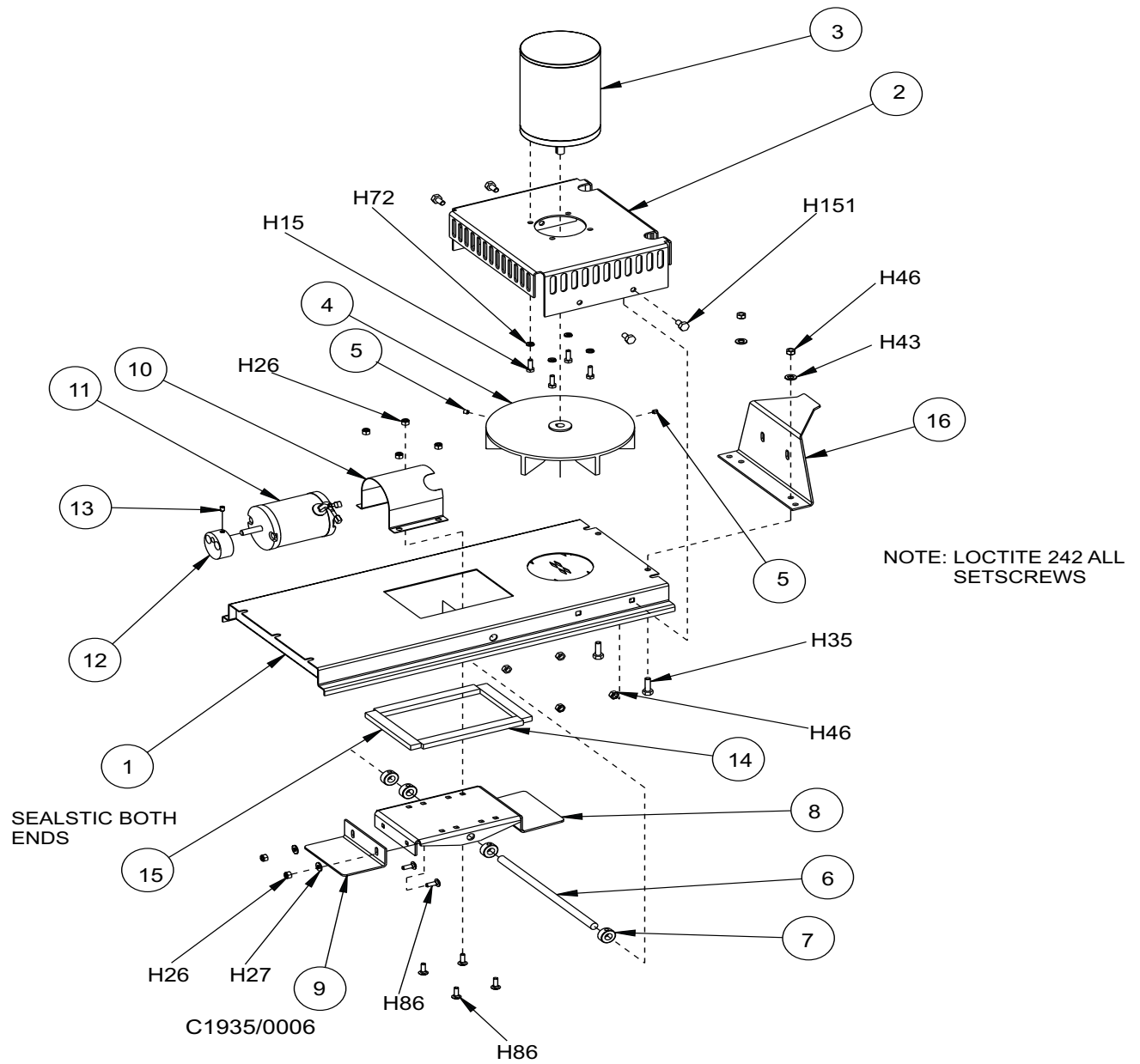

**DUST CONTROL (cont.)**

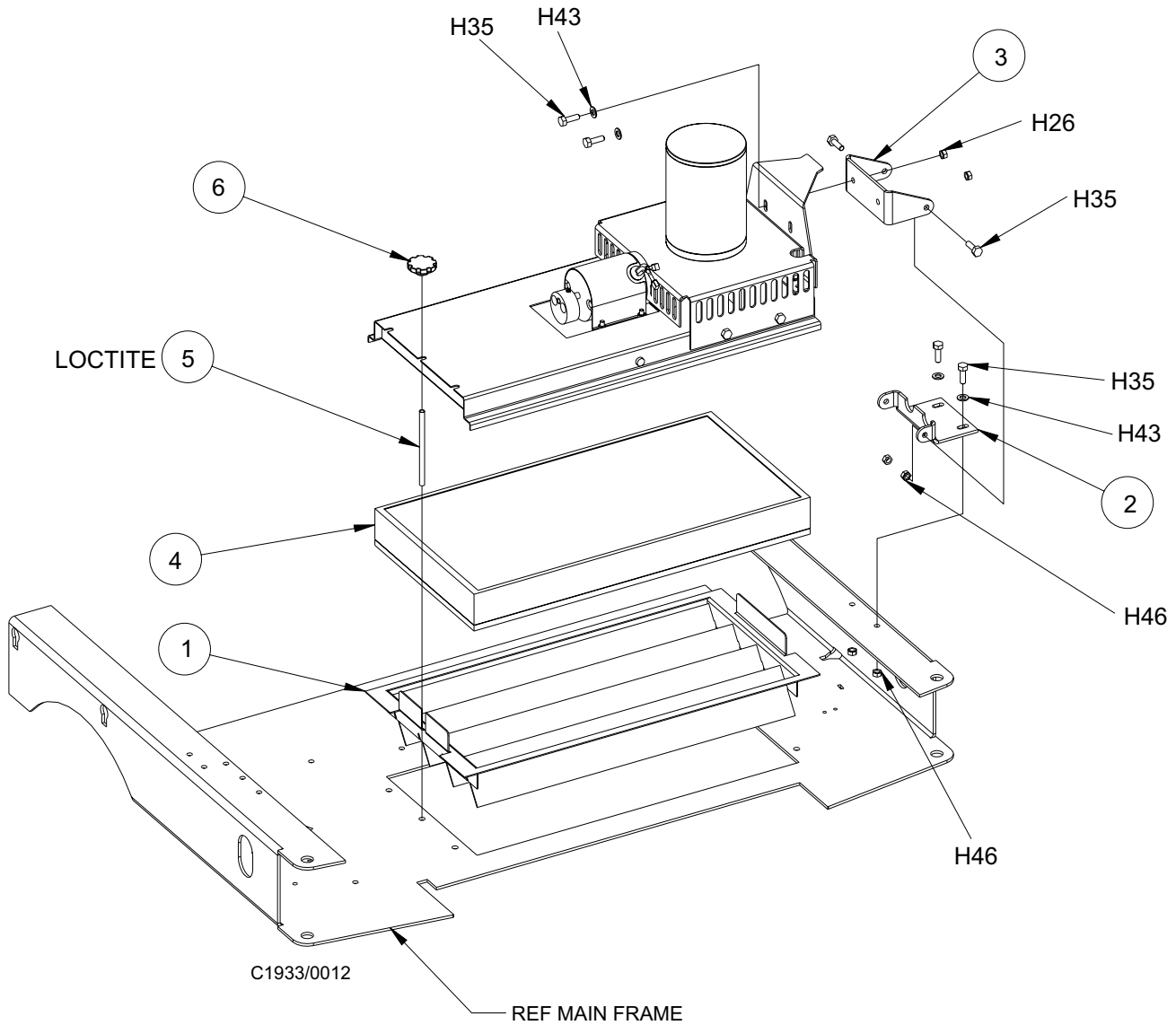

<b>Key No.</b>	<b>Part Number</b>	<b>Description</b>	<b>Qty.</b>
1	7-05-01004	Baffle - Filter	1
2	7-08-00960	Bracket - Manifold Pivot	1
3	7-57-05061	Pivot - Imp. Manifold	1
4	8-24-04074-1	Filter - Panel	1
5	8-80-05038	Rid - Threaded (5/16-18)	1
6	7-39-00006	Knob	1

**HARDWARE USED:**

H26	2-00-00641	Nut, 1/4-20 Insert Fiber	2
H35	2-00-02708	Screw, 5/16-18 x 1.000 HHM	4
H43	2-00-00409	Flat Washer, .687 x .344 x .062	4
H46	2-00-00644	Nut, 5/16-18, Insert Fiber	4

C1933/0012

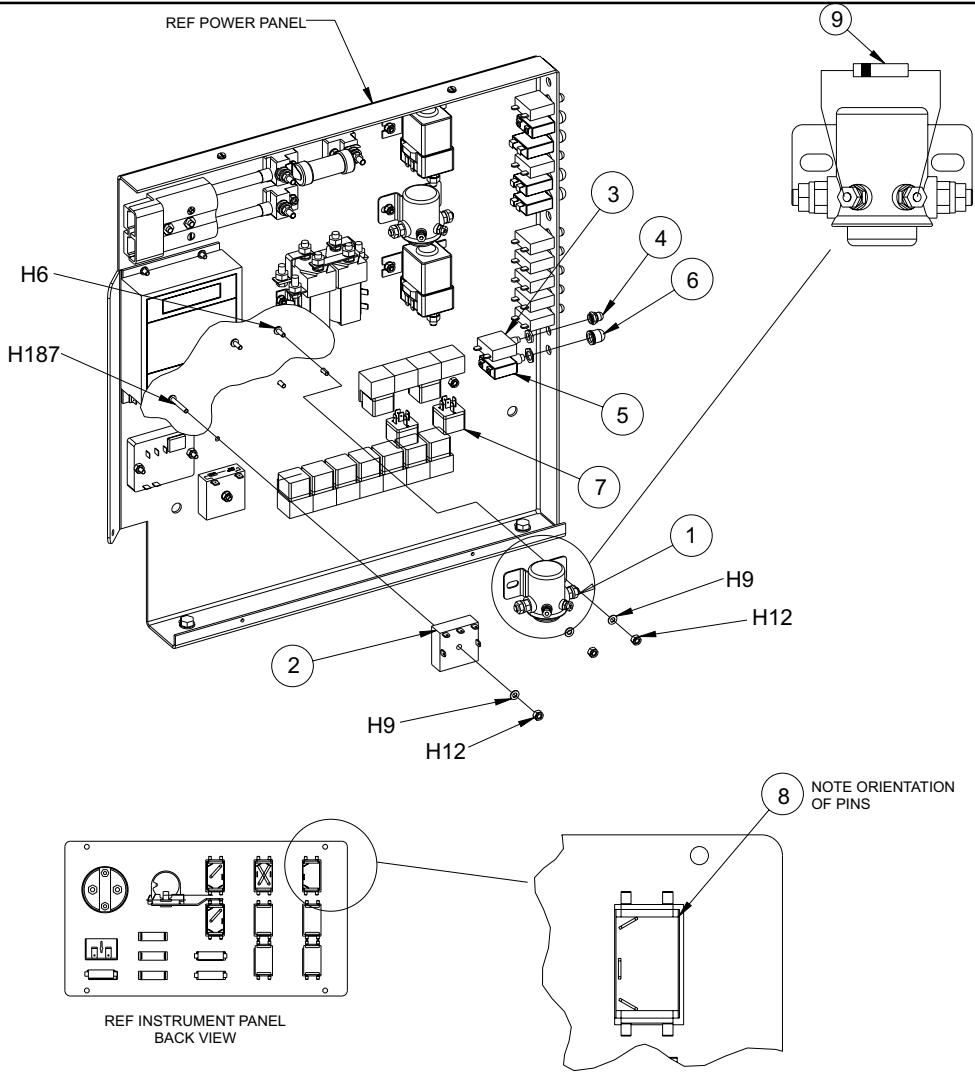

C1974/0102

<b>Key No.</b>	<b>Part Number</b>	<b>Description</b>	<b>Qty.</b>
1	2-00-04825	Solenoid	1
2	8-64-00020	20 Second Timed Relay	1
3	8-64-00008	Circuit Breaker (25 AMP) CB-14	1
4	8-11-00044	Boot	1
5	7-64-00025	Circuit Breaker - 25 Amp	1
6	8-11-00051	Boot (7/16)	1
7	7-64-00037	Relay - 36v w/ Diode Assembly	2
8	7-82-00044	Switch	1
9	0775-159	Diode Assembly	1

**HARDWARE USED:**

H6	2-00-00049	Screw, #10-24 x .500 RHM	2
H9	2-00-00426	Flatwasher, .500 x .219 x .063	3
H12	2-00-01246	Nut, Hex Fiber Insert #10-24	3
H187	2-00-00071	Screw, #10-24 x 1.250 RHM	1

C1974/0102

## **VAC MANIFOLD SYSTEM - PARTS LIST**

---

<b><u>Key No.</u></b>	<b><u>Part Number</u></b>	<b><u>Description</u></b>	<b><u>Qty.</u></b>
1	7-48-00036	Manifold, Vacuum (Weldment)	1
2	7-58-05213	Plate, Vac Motor Mount	2
3	8-88-00016	Unloader Valve	1
4	2-00-03407	Hose Clamp - Wittick #10P	1
5	2-00-02216	Hose Clamp	2
6	7-33-02395	Hose, Flexible (43" LG)	1
7	7-06-05007	Block Terminal	1
8	2-22-00003	Motor Mounting Ring	4
9	0782-117	Motor 36V 3 Stage Vacuum	2
10	7-80-05083	Stud, Vac Motor	8

### **HARDWARE USED:**

H7	2-00-00056	Screw, #10 - 24 x .750 RHM	4
H12	2-00-01246	Nut, Hex Fiber Insert #10 - 24	8
H15	2-00-00221	Screw, 1/4 - 20 x .750 HHC	2
H72	2-00-00518	Lock Washer, Helical Spring	2
H348	2-00-04446	Terminal	4

C1909/0005

VAC MANIFOLD SYSTEM - EXPLODED VIEW

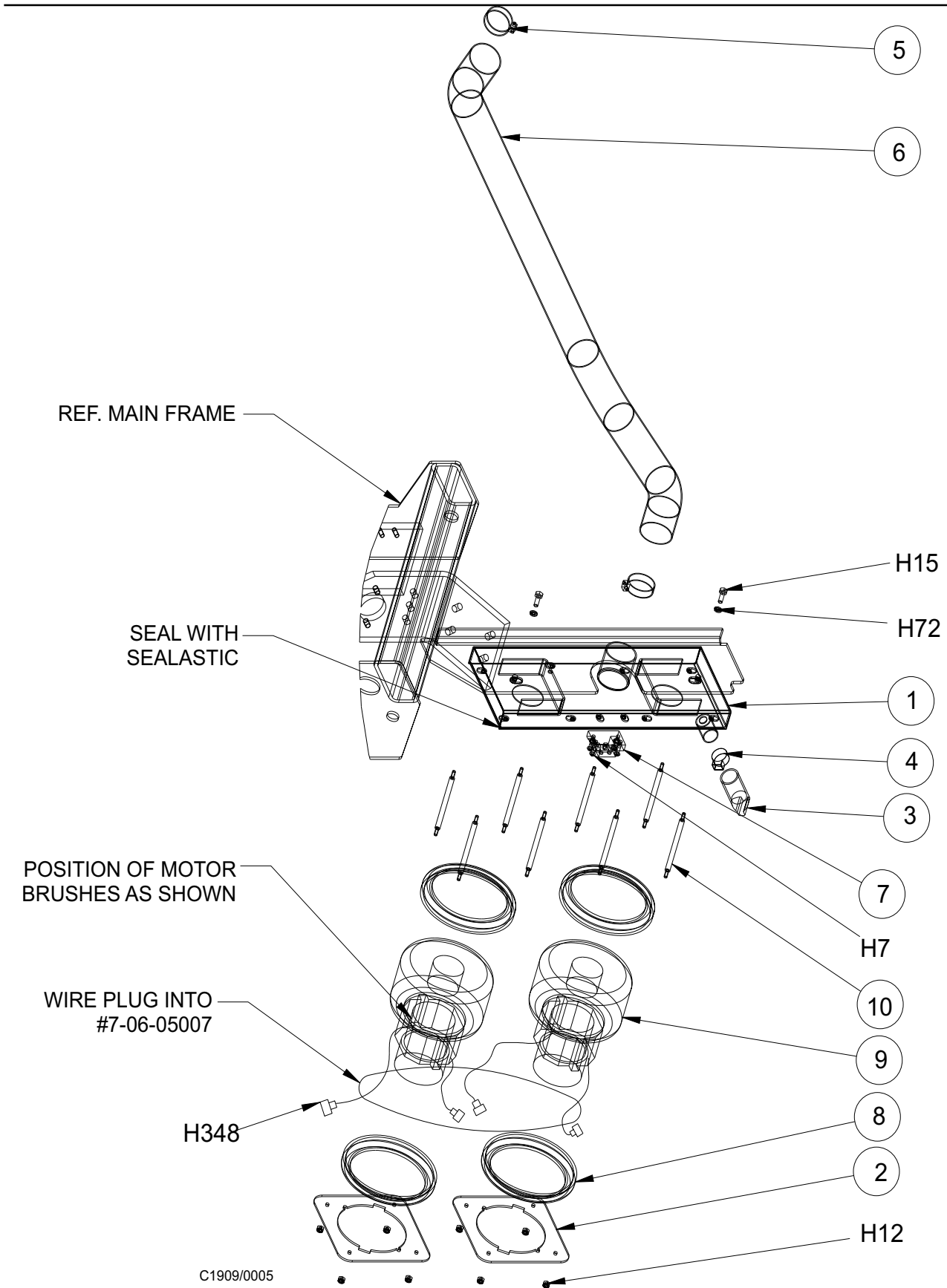

## **HYDRAULIC MOTOR AND PUMP ASSEMBLY - PARTS LIST**

---

<b><u>Key No.</u></b>	<b><u>Part Number</u></b>	<b><u>Description</u></b>	<b><u>Qty.</u></b>
1	7-08-00975	Weldment - Hyd Mtg	1
2	7-60-05036	Pump - Hyd	Ref.
3	2-00-00718	Key - 3/16 x 3/4 (#9) Woodruff	1
4	2-95-04182	Nut - 3/8-16 Elastic Stop Nut	3
5	0782-148	Motor - Electric (5 HP, 36 VDC)	1
6	7-60-05037	Coupling Assembly	1

### **HARDWARE USED:**

H48	2-00-00233	Screw, 3/8-16 x 1.000 HHC	4
H53	2-00-02310	Lock Washer, Helical Spring 3/8 Med.	4
H182	2-00-00236	Screw, 3/8-16 x 2.500 HHC	4

C1957/0102

**HYDRAULIC MOTOR AND PUMP ASSEMBLY - EXPLODED VIEW**

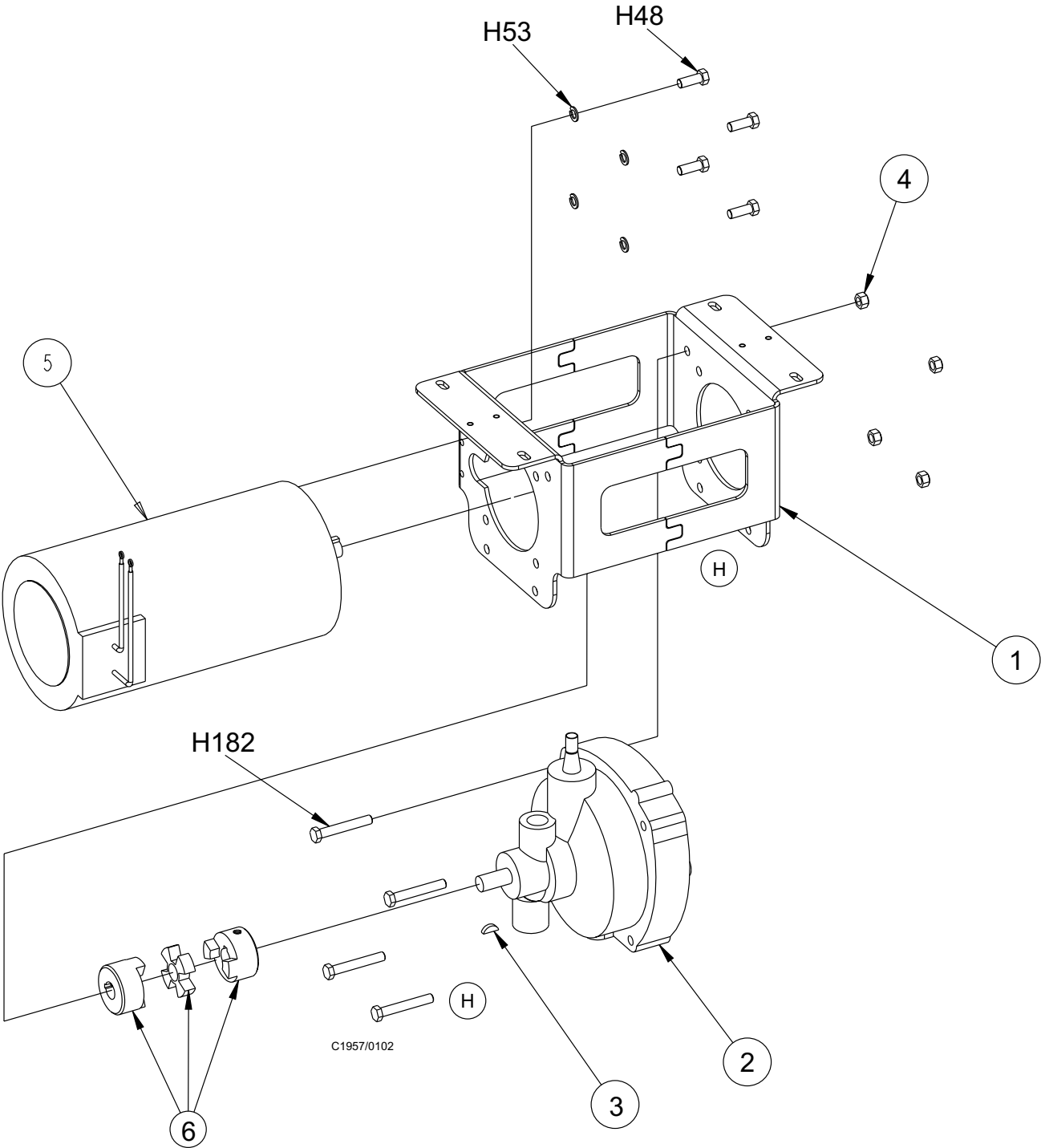

# MOTOR AND PUMP MOUNTING ASSEMBLY

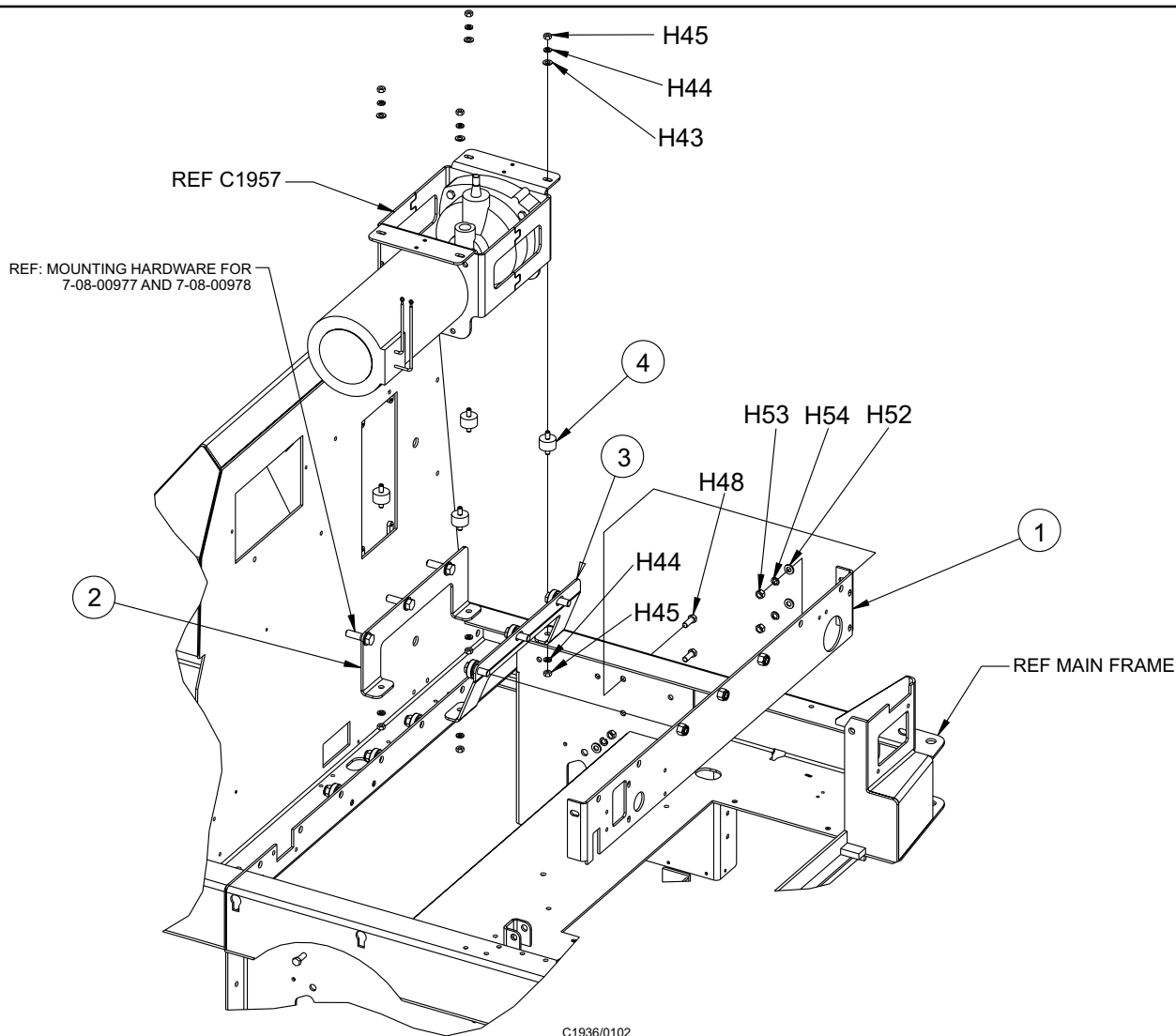

C1936/0102

<u>Key No.</u>	<u>Part Number</u>	<u>Description</u>	<u>Qty.</u>
1	7-81-00224	Support - Battery	1
2	7-08-00977	Brkt. - Rear Mtr. Mtg	1
3	7-08-00978	Brkt. - Front Mtr. Mgt.	1
4	8-50-05037	Pad - Radiator Mount	4

## HARDWARE USED:

H43	2-00-00409	Flat Washer, .687 x .344 x .062	4
H44	2-00-00530	Lock Washer, 5/16 HS Med.	8
H45	2-00-00585	Nut, Hex. 5/16-18 x .500 x .265	8
H48	2-00-00233	Screw, 3/8-16 X 1.000 HHC00	3
H52	2-00-00402	Flat Washer, .750 x .390 x .094	3
H53	2-00-02310	Lock Washer, Helical Spring 3/8 Med.	3
H54	2-00-02360	Nut, 3/8-16 Hex.	3

C1936/0102

# HYDRAULIC RESERVOIR ASSEMBLY

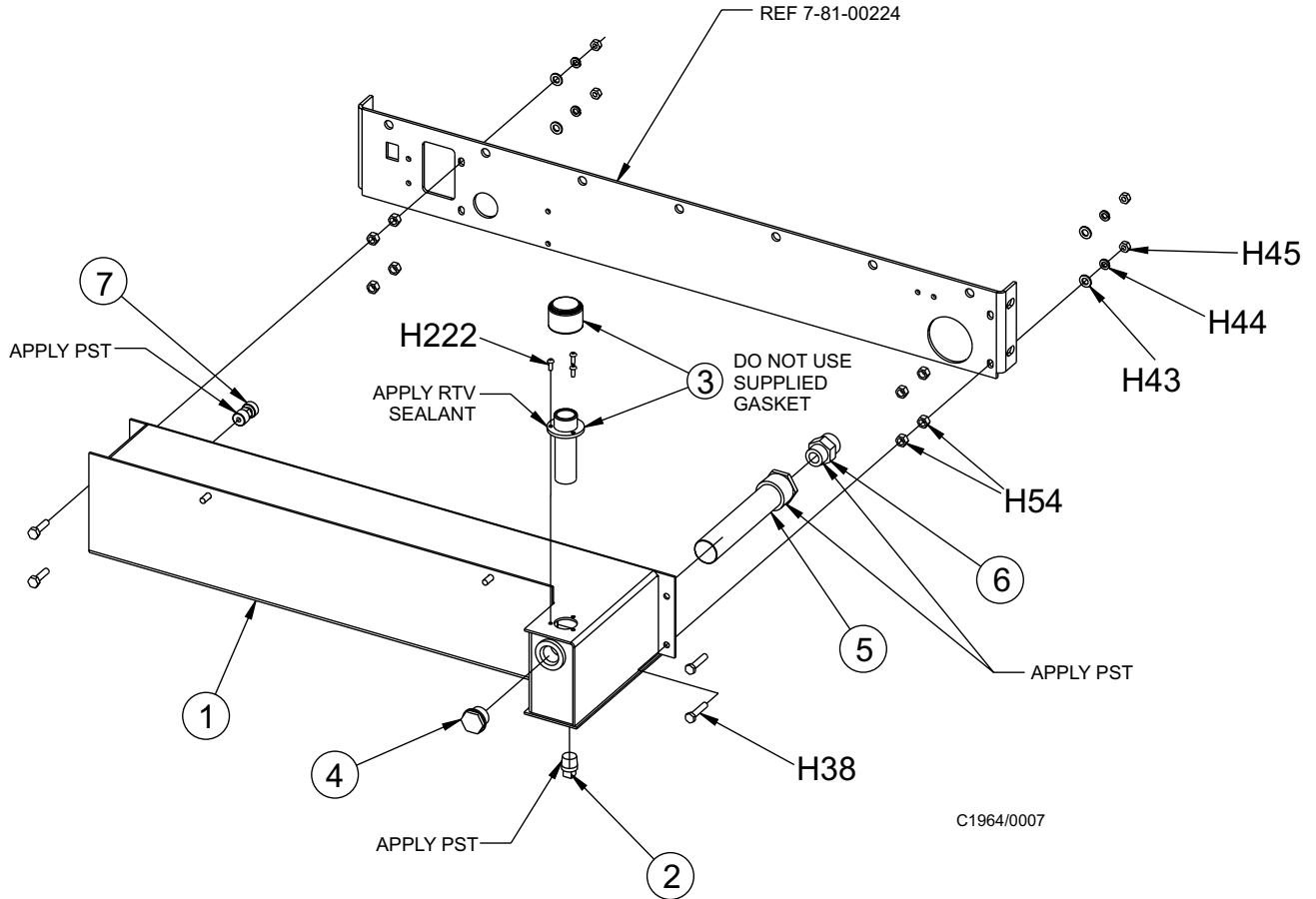

<u>Key No.</u>	<u>Part Number</u>	<u>Description</u>	<u>Qty.</u>
1	7-83-04183	Reservoir	1
2	2-00-02474	Plug - 1/2 NPT	1
3	7-11-00033	Filter Breather	1
4	8-48-05033	Sight Glass (Hyd. Fluid)	1
5	8-24-04115	Strainer - Hydraulic Reservoir	1
*6	2-00-05453	Fitting - 12RFS - 1/2 NPT, STR	Ref.
*7	2-00-05439	Fitting - ORS M TO NPTF M 08 X 08	Ref.

\* ITEMS ARE PART OF HYDRAULIC KIT 0760-546

**HARDWARE USED:**

H38	2-00-00225	Screw, 5/16-18 x 1.500 HHC	4
H43	2-00-00409	Flat Washer, .687 x .344 x .062	4
H44	2-00-00530	Lock Washer, 5/16 HS Med.	4
H45	2-00-00585	Nut, Hex. 5/16-18 x .500 x .265	4
H54	2-00-02360	Nut, 3/8-16 Hex.	8
H222	2-00-02848	Screw, 10-32 x .50 Cad PL, STL RHM	3

C1964/0106

**HYDRAULIC FILTER AND SOLENOID ASSEMBLY - PARTS LIST**

<u>Key No.</u>	<u>Part Number</u>	<u>Description</u>	<u>Qty.</u>
*1	7-60-05036	Pumo - Hyd	Ref.
2	7-08-00980	Brkt - Filter Mtg	1
*3	7-24-04013	Filter Assembly, Return	Ref.
4	7-08-00984	Brkt - Valve Mtg	1
*5	7-88-00081	Valve - Solenoid (36V)	Ref.
*6	2-00-04916	Plug - 9/16-16 O-Ring Boss	Ref.
*7	2-00-05452	Fitting - 12ORFS - 100RB, Str.	Ref.
*8	2-00-04921	Fitting - 10SAE 90° - 8ORS	Ref.
*9	2-00-04977	Fitting - 8ORS - 6SAE Str.	Ref.
*10	2-00-05441	Fitting, Long Str Male ORFS to ORS Boss 06x06	Ref.
*11	2-00-05440	Fitting - ORFS Female Swivel to ORS Boss M 06	Ref.
*12	2-00-04975	Fitting - 8SAE 45° Elbow	Ref.
*13	2-00-04924	Fitting - 3/4-16 x 13/16-16 Tee	Ref.
*14	2-00-04957	Fitting - Cap 8ORS	Ref.
*15	2-00-05437	Fitting - 90 ORS to ORS Boss 08 x 06	Ref.
*16	2-00-05438	Fitting - 90 ORS M to NOTF M 08 x 12	Ref.
*17	2-00-04928	Fitting - 13/16-16 x 13/16-16 Tee	Ref.
*18	2-00-04885	Fitting - 90° Elbow (O-Ring)	Ref.
*19	2-00-05436	Fitting - ORFS M to NPTF M 08 x 12	Ref.
20	7-88-00085	Valve - Broom Actuator	1
*21	2-00-05480	Fitting - Long 90° Elbow (O-Ring)	Ref.
*22	2-00-04892	Fitting - 90° Elbow (O-Ring)	Ref.
*23	2-00-05435	Fitting - 90 Orfs to Ors Boss 06 x 06	Ref.
*24	2-00-05481	Fitting - Orfs to Ors Boss 06 x 06, Tee	Ref.
*25	2-00-05477	Fitting - Reducer, 8Orfs to 6Orfs	Ref.
26	7-87-02204	Tube - Broom Manifold	1

\* ITEMS ARE PART OF HYDRAULIC KIT 0760-546

**HARDWARE USED:**

H15	2-00-00221	Screw, 1/4-20 x .750 HHC	4
H21	2-00-01769	Screw, 1/4-20 x 1.750 HHC	2
H26	2-00-00641	Nut, 1/4-20 Insert Fiber	2
H27	2-00-03702	Washer, .625 x .281 x .063	6
H46	2-00-00644	Nut, 5/16-18, Insert Fiber	2
H72	2-00-00518	Lock Washer, Helical Spring	4

C1965/0101

# HYDRAULIC FILTER AND SOLENOID ASSEMBLY - EXPLODED VIEW

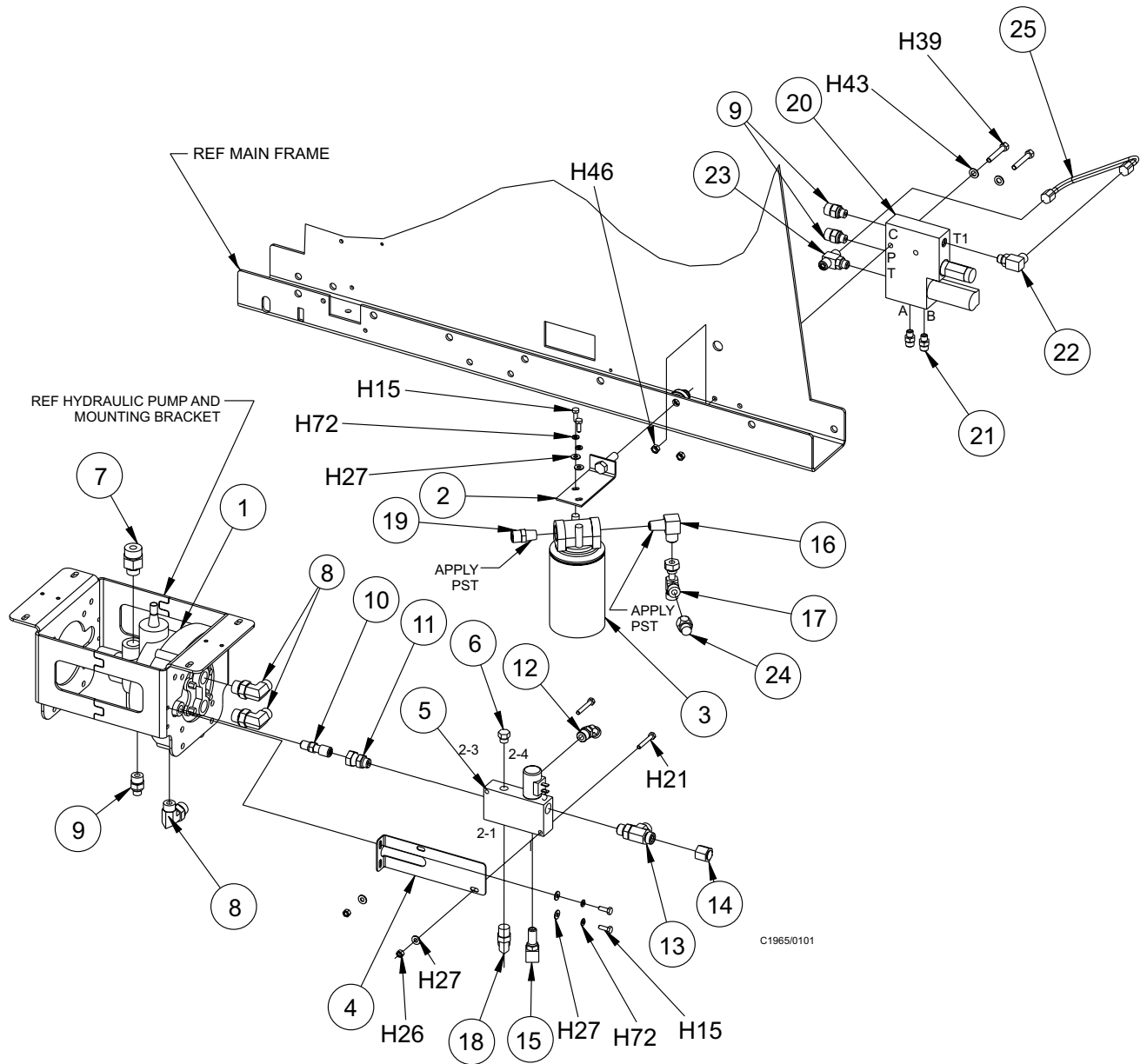

## HYDRAULIC CONNECTION DIAGRAM - PARTS LIST

---

<u>Key No.</u>	<u>Part Number</u>	<u>Description</u>	<u>Qty.</u>
*1	7-33-02416	Hose - #6 Str-Str, 11/16-16 - 13/16-16, 64.0 Lg	Ref.
*2	7-33-02412	Hose - #8 Str-90, 13/16-16 - 11/16-16, 56.0 Lg	Ref.
*3	7-33-02446	Hose-#12 Str-90, 1 3/16-16 Both End, 22.5 ±.25Lg	Ref.
4	7-33-02417	Hose - #8 Str-45, 13/16-16 Both Ends, 27.0 Lg.	Ref.
*5	7-33-02402	Hose - #8 Str-90, 13/16-16 Both Ends, 22.0 Lg	Ref.
*6	7-33-02428	Hose - #8 Str-90, 13/16-16 Both Ends, 57.0 Lg	Ref.
*7	7-33-02414	Hose - #8 Str-Str, 13/16-16 Both Ends, 82.0 Lg	Ref.
*8	7-33-02431	Hose - #6 Str-Str, 13/16-16 Both Ends, 82.0 Lg	Ref.
*9	8-33-02325	Hose - #8 Str-Str, 13/16-16 Both Ends, 65.0 Lg	Ref.
*10	7-33-02184	Hose - #4 Str-Str, 9/16-18 Both Ends, 50.5 Lg	Ref.
*11	8-33-02179	Hose - #4 Str-Str, 9/16-18 Both Ends, 46.0 Lg	Ref.
*12	7-33-02191	Hose - #4 Str-Str, 9/16-18 Both Ends, 42.0 Lg	Ref.
*13	7-33-02225	Hose - #4 Str-90, 9/16-16 Both Ends, 38.0 Lg	Ref.
*14	7-33-02222	Hose - #8 Str-Str, 13/16-16 Both Ends, 26.0 Lg	Ref.
*15	7-33-02438	Hose - #8 Str-Str, 13/16-16 Both Ends, 51.0 Lg	Ref.
*16	7-33-02439	Hose - #6 90-45, 11/16-16 Both Ends, 20.0 Lg	Ref.
17	7-87-02204	Tube - Broom Manifold	Ref.

\*All Items are part of Hydraulic Kit 0760-546

C1966/0102

# HYDRAULIC CONNECTION DIAGRAM - EXPLODED VIEW

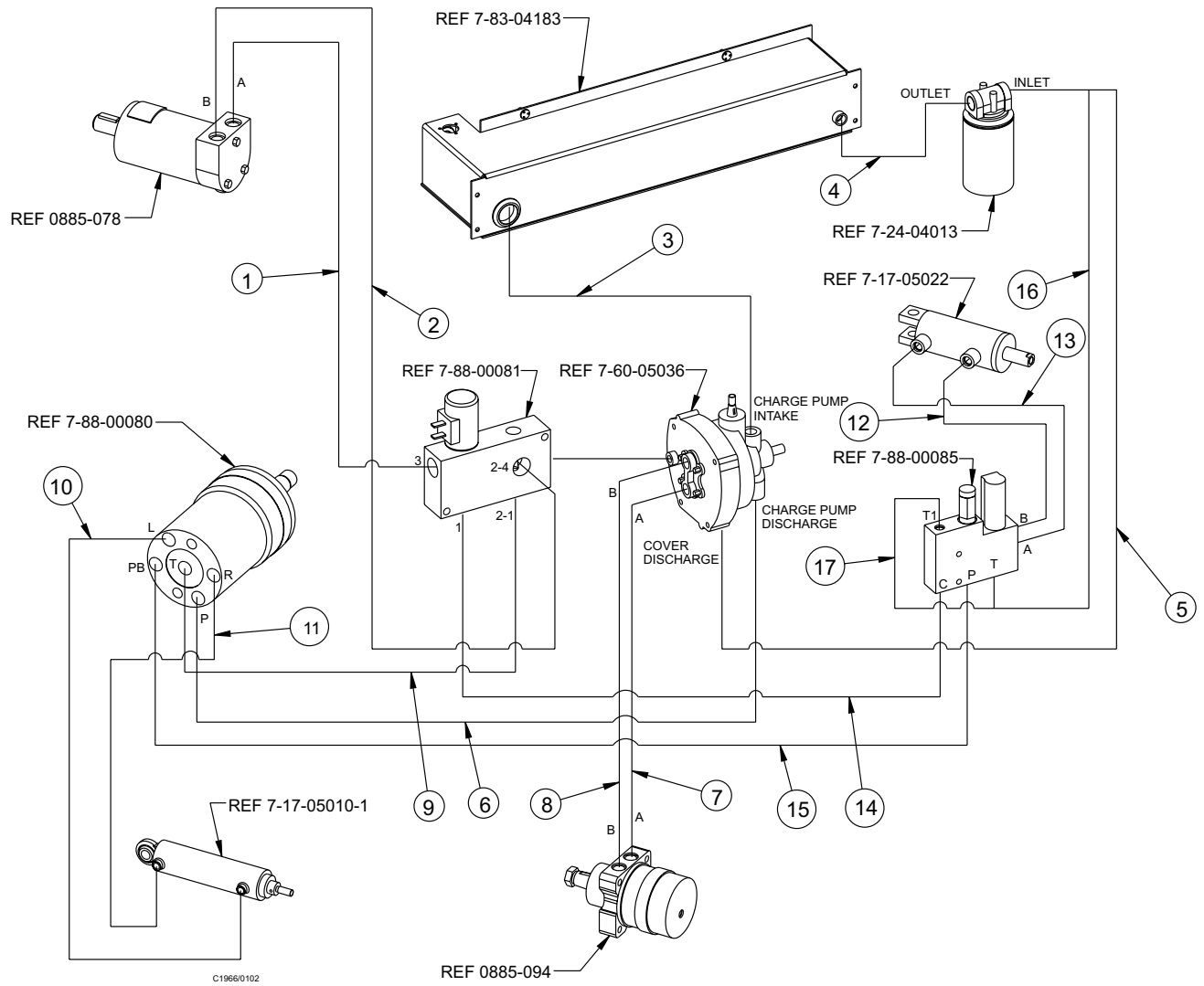

## **POWER PANEL (36V) - PARTS LIST**

---

<b><u>Key No.</u></b>	<b><u>Part Number</u></b>	<b><u>Description</u></b>	<b><u>Qty.</u></b>
1	7-52-00176	Panel - Power	1
2	0775-225	Wire Ass'y - Battery to Power Panel	1
3	8-06-05004	Terminal Block	3
4	2-00-04825	Solenoid	1
5	7-64-00023	36 v/vdc Shutdown N.C.	1
6	8-64-00008	Circuit Breaker - 15 Amp	7
7	8-11-00044	Boot	7
8	7-64-00032	Circuit Breaker - 50Amp	1
9	8-11-00051	Cap - Clear Boot	4
10	7-64-00020	Circuit Breaker -45 Amp	2
11	8-28-05021	Fuse (120 Amp)	1
12	8-74-00014	Solenoid - Power Panel	1
13	0775-238	Controller - Motor	1
14	7-64-00037	Relay - 36v w/ Diode Assembly	9
15	7-64-00038	Relay - Time Delay (3 sec on Load)	1
16	7-64-00025	Circuit Breaker -25 Amp	1
17	7-52-00180	Panel - Power	1
18	7-15-08009	Contactora - WR Type 586, SPNO	2

### **HARDWARE USED**

H6	2-00-00049	Screw, # 10-24 x .500 RHM	14
H8	2-00-00039	Screw, 10-24 x 1.000 RHM	3
H9	2-00-00426	Flat Washer, .500 x .219 x .063	16
H12	2-00-01246	Nut, Hex Fiber Insert #10-24	26
H15	2-00-00221	Screw, 1/4-20 x .750 HHC	2
H20	2-00-00203	Screw, 1/4-20 x 1.500 HHC	2
H25	2-00-00594	Nut, Hex 1/4-20 x .437 x .218	6
H26	2-00-00641	Nut, 1/4-20 Insert Fiber	2
H27	2-00-03702	Washer, .625 x .281 x .063	6
H72	2-00-00518	Lock Washer, Helical Spring	3
H187	2-00-00071	Screw, #10-24 x 1.250 RHM	3
H363	2-00-02336	Screw, HHC, .375-16 x 2.75	2

C1983/0106

**POWER PANEL (36V) - EXPLODED VIEW**

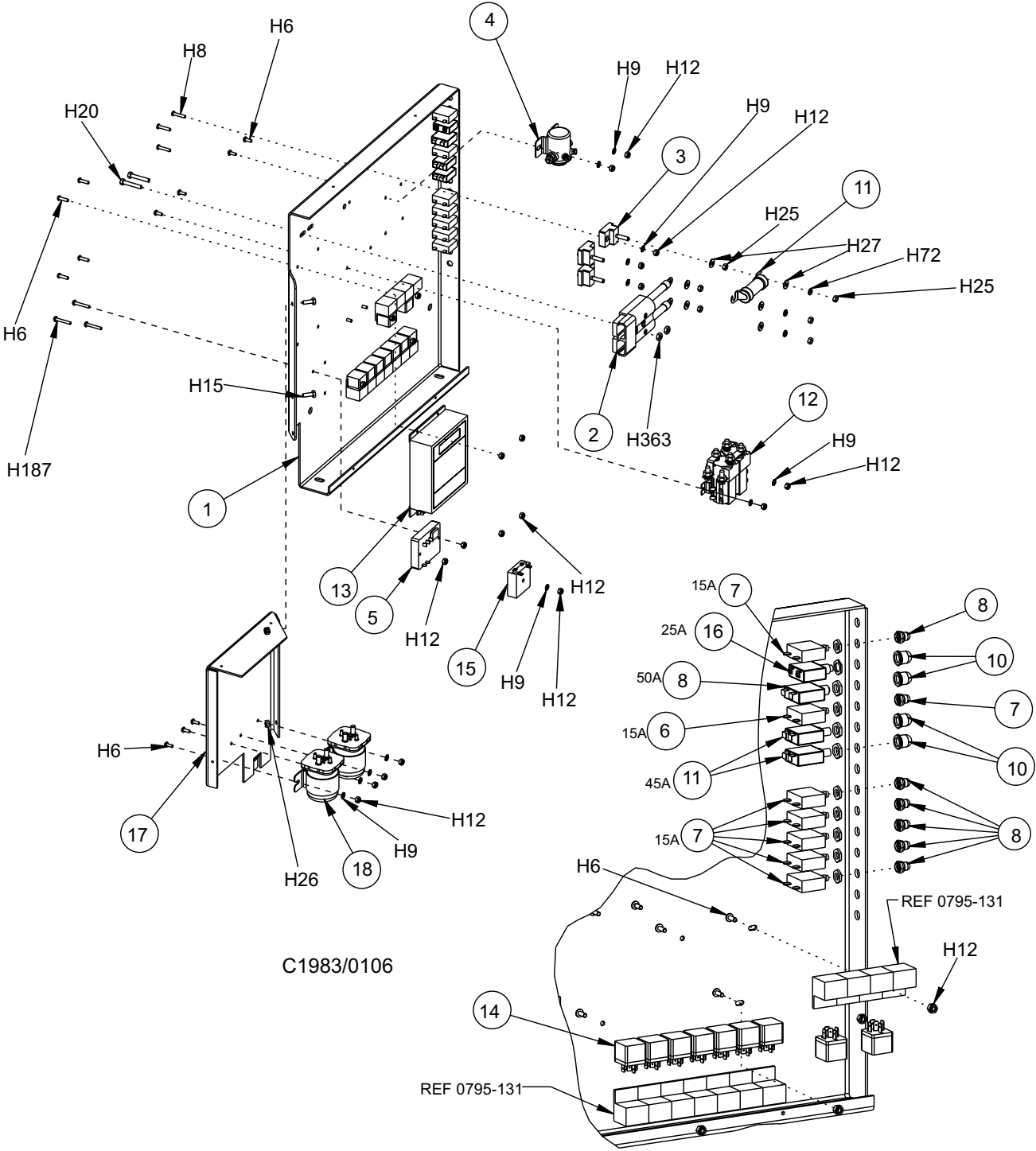

**POWER PANEL (36V) Cont - PARTS LIST**

---

<u>Key No.</u>	<u>Part Number</u>	<u>Description</u>	<u>Qty.</u>
1	7-16-07421	Cover - Power Panel	1
2	7-35-00023	Insulation - Power Panel Cover	1
3	7-16-07436	Cover - Power Panel	1
4	7-35-00024	Insulation - Power Panel	1
<b><u>HARDWARE USED</u></b>			
H34	2-00-00208	Screw, 5/16 - 18 X .750 HHC	2
H43	2-00-00409	Flat Washer, .687 x .344 x .063	4
H46	2-00-00644	Nut, 5/16-18 Insert Fiber	4
H136	2-00-03940	Screw, #10-24 x .500 T/C HHC	5

C1984/0106

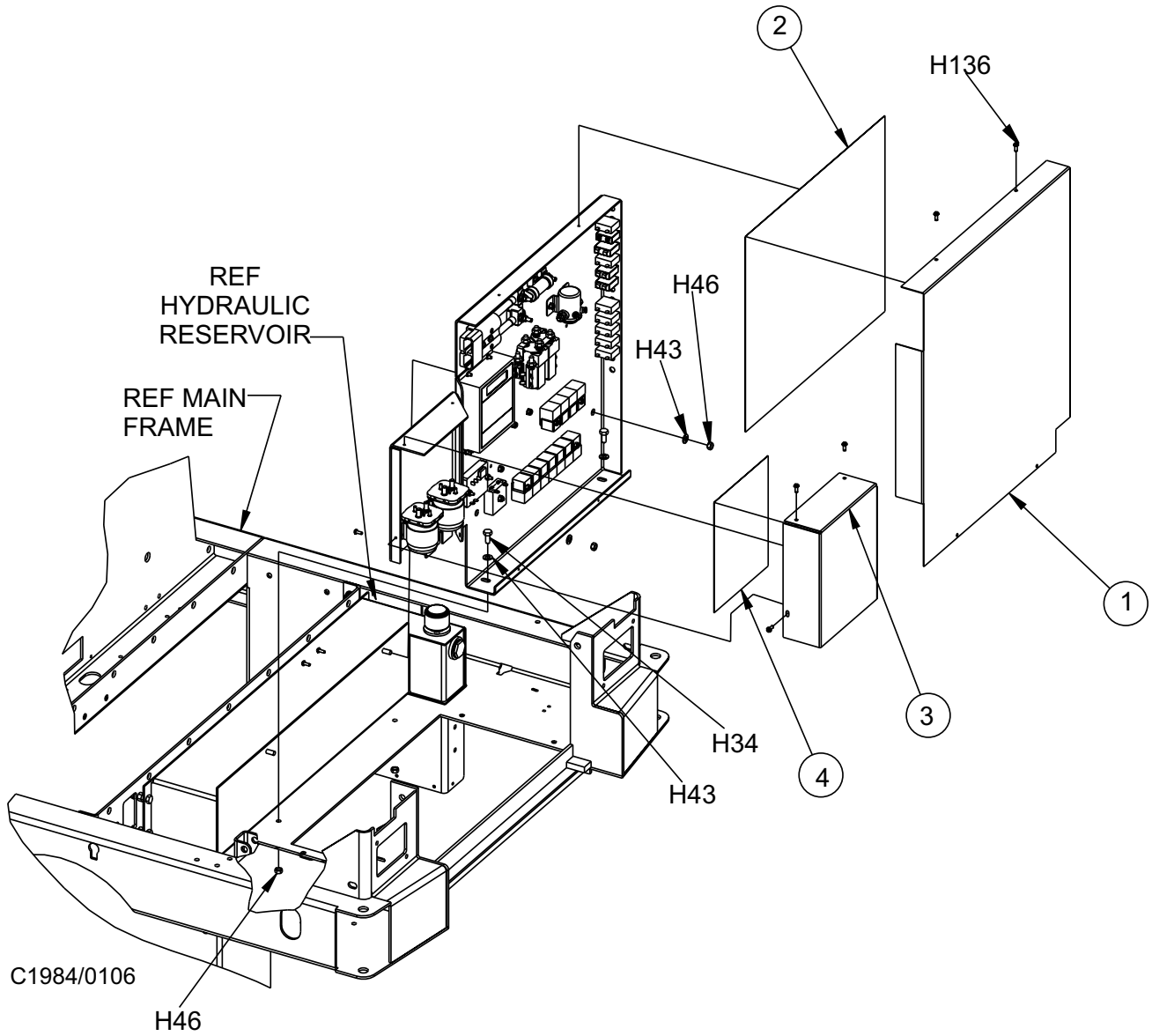

**POWER PANEL (36V) Cont - PARTS LIST**

---

<u>Key No.</u>	<u>Part Number</u>	<u>Description</u>	<u>Qty.</u>
1	0795-131	Harness-Power Panel	1
2	0775-159	Diode Assembly	3
3	0775-188	Diode Assembly	2
4	0775-161	Diode Assembly	2
5	0775-239	Diode Assembly	1
6	7-28-05015	Fuse - 25ATC	1

C1985/0106



## **POWER STEERING - PARTS LIST**

---

<b><u>Key No.</u></b>	<b><u>Part Number</u></b>	<b><u>Description</u></b>	<b><u>Qty.</u></b>
1	7-81-00216	Support - Steering Valve	1
2	7-88-00080	Valve - Steering Control	1
3	7-89-08094	Wheel - Steering (KELCH)	1
4	7-16-07428	Cover - Steering Wheel	1
5	2-00-04918	Fitting Straight Connector	2
6	2-00-04977	Fitting - 8ORS - 6SAE, STR.	3
7	7-33-02426	Hose - Steering	1
8	7-59-00003	Plunger - Steering	1
9	7-16-07427	Cover - Hydraulic Hose	1
10	2-95-04182	Nut - 3/8-16 Elastic Stop Nut	4
11	962987	Screw 10-24 x 3/8 PN *St Typ23	3

### **TABLE A - (for Port to 7-88-00080)**

<b><u>PORT</u></b>	<b><u>FITTING</u></b>
P	2-00-04977
PB	2-00-04977
T	2-00-04977
R	2-00-04918
L	2-00-04918

### **HARDWARE USED:**

H47	2-00-00232	Screw, 3/8-16 x .750 HHC	2
H129	2-00-02311	Lock Washer, 4.38 Split	2
H184	2-00-04366	Screw, M10 x 1.500 x 25mm	2
H320	2-00-05424	Screw, Shoulder 1/2-1/2	2
H349	2-00-02779	Fhms -#10-32 x .312	2
H362	2-00-00427	Flat washer, .875 x .516 x .063 stl.	2
H370	2-00-05433	Nut, Hex M16 x 1.5 Steel/Plain	1

C1955/0012

**POWER STEERING - EXPLODED VIEW**

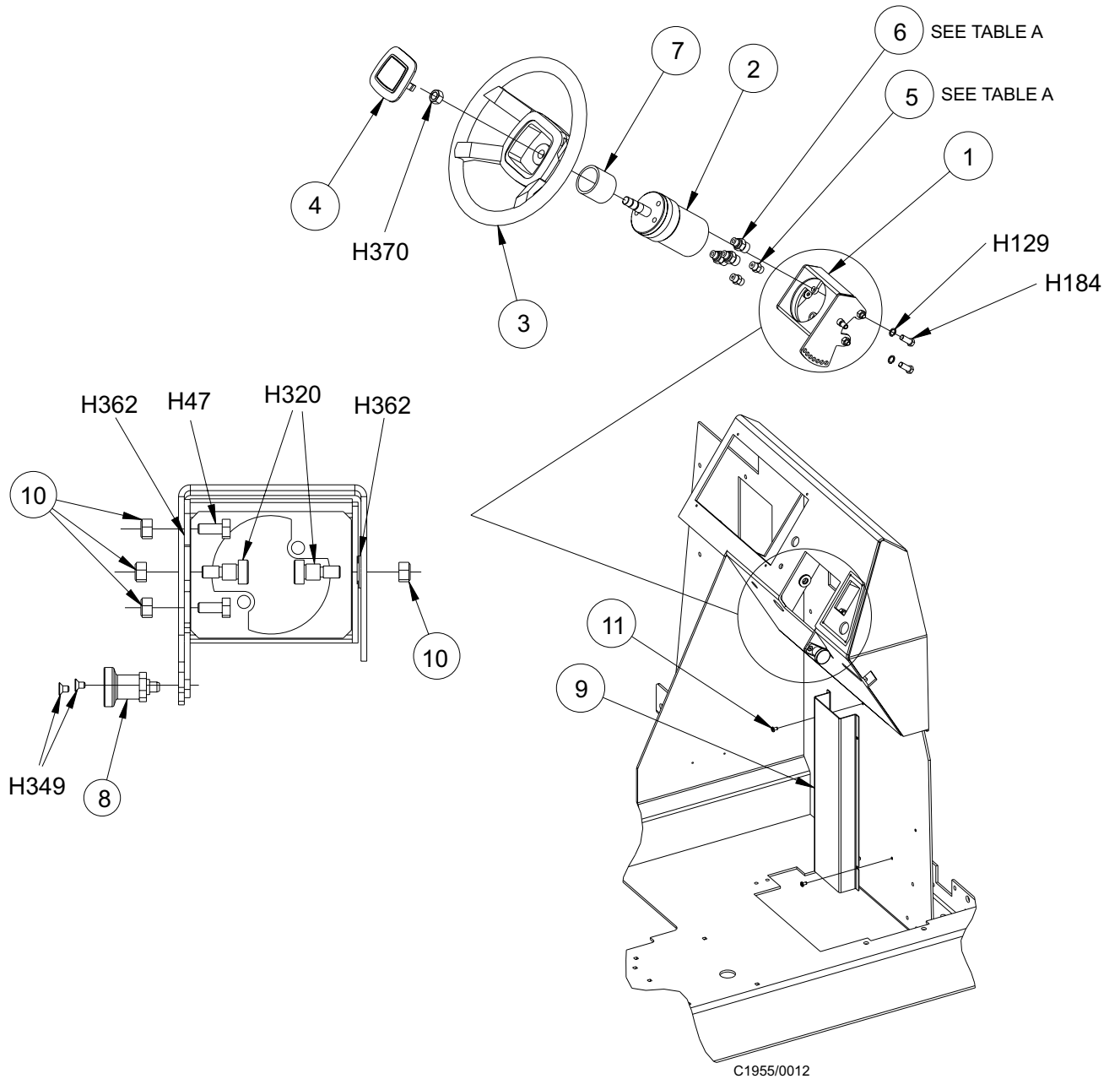

## **ELECTRICAL POWER PANEL (36V) - PARTS LIST**

---

<b><u>Key No.</u></b>	<b><u>Part Number</u></b>	<b><u>Description</u></b>	<b><u>Qty.</u></b>
1	7-52-00176	Panel - Power	1
2	0775-225	Wire Assembly - Battery to Power Panel	1
3	8-06-05004	Terminal Block	3
4	7-74-00007	Contacto	2
5	2-00-04825	Solenoid	1
6	7-64-00023	36V/VDC Shutdown N.C.	1
7	8-64-00008	Circuit Breaker (15 AMP)	7
8	8-11-00044	Boot	7
9	7-64-00032	Circuit Breaker (50 AMP)	1
10	8-11-00051	Cap - Clear Boot	4
11	7-64-00020	Circuit Breaker (45 AMP)	2
12	8-28-05021	Fuse (120 AMP)	1
13	8-74-00014	Solenoid, Power Panel	1
14	0775-238	Controller - Motor	1
15	7-64-00037	Relay - 36v w/ Diode Assembly	9
16	7-64-00038	Relay - Time Delay (3 sec on Load)	1
17	7-64-00025	Circuit Breaker - 25 Amp	1
18	7-16-07421	Cover - Power Panel	1
19	7-35-00023	Insulation - Power Panel Cover	1

### **HARDWARE USED:**

H6	2-00-00049	Screw, #10-24 x .500 RHM	10
H8	2-00-00039	Screw, 10-24 x 1.000 RHM	3
H9	2-00-00426	Flat Washer, .500 x .219 x .063	12
H12	2-00-01246	Nut, Hex Fiber Insert #10-24	22
H20	2-00-00203	Screw, ¼-20 x 1.500 HHC	2
H25	2-00-00594	Nut, Hex ¼ - 20 x .437 x .218	6
H27	2-00-03702	Washer, .625 x .281 x .063	6
H34	2-00-00208	Screw, 5/16-18 x .750 HHC	2
H43	2-00-00409	Flat Washer, .687 x .344 x .062	4
H46	2-00-00644	Nut 5/16-18, Insert Fiber	4
H72	2-00-00518	Lock Washer, Helical Spring	3
H136	2-00-03940	Screw, #10-24 x .500 T/C HH	2
H187	2-00-00071	Screw, #10-24 x 1.2500 RHM	3
H363	2-00-02336	Screw, HHC, .375-16 x 2.75	2

C1926/0102



## **INSTRUMENT PANEL - PARTS LIST**

---

<b><u>Key No.</u></b>	<b><u>Part Number</u></b>	<b><u>Description</u></b>	<b><u>Qty.</u></b>
1	7-52-00171	Panel - Instrument	1
2	7-48-05024	Meter - Battery Condition	1
3	7-40-05041	Light - (32V0 Amber	3
4	7-48-05029	Meter - Hour	1
5	7-82-00041	Switch - Double Pole, Triple Throw (ON-ON-ON)	2
6	7-82-00042	Switch - Motor Reversing	1
7	2-00-05375	Blank - McGill Switch	5
8	8-82-00041	Key Switch (Ignition)	1
9	7-10-00040	Control - Solution	1
10	7-10-00034	Cable - Solution Control	Ref.
11	7-18-00270	Decal - Instrument Panel (36V)	1
12	2-00-05418	Blank - Light (Black)	3
13	7-32-09003	Alarm - Chime	1
14	8-82-00030	Switch - Push Button Lid	1
15	2-00-04757	Plug Button, .375 Dia.	1
16	2-00-05382	Hole Plug	1
17	2-00-04250	Clamp	1
18	7-52-00177	Panel - Broom Lift Switch	1
19	7-18-00279	Decal - Broom Lift Switch	1
20	7-82-00039	Switch - Single Pole, Single Throw (On-On)	1
21	0795-128	Harness - Instrument Panel	1
22	0775-227	Diode Assembly	1
23	0775-234	Resistor Assembly	1

NOTE: Harness 0795-128 Not Shown

### **HARDWARE USED:**

H6	2-00-00056	Screw, #10-24 x .500 RHM	1
H9	2-00-00426	Flatwasher, .500 x .219 x .063	1
H12	2-00-01246	Nut, Hex Fiber Insert #10-24	2
H176	2-00-05337	Screw, #8-32 x .750 BHS SS	8

C1939/0012

**INSTRUMENT PANEL - EXPLODED VIEW**

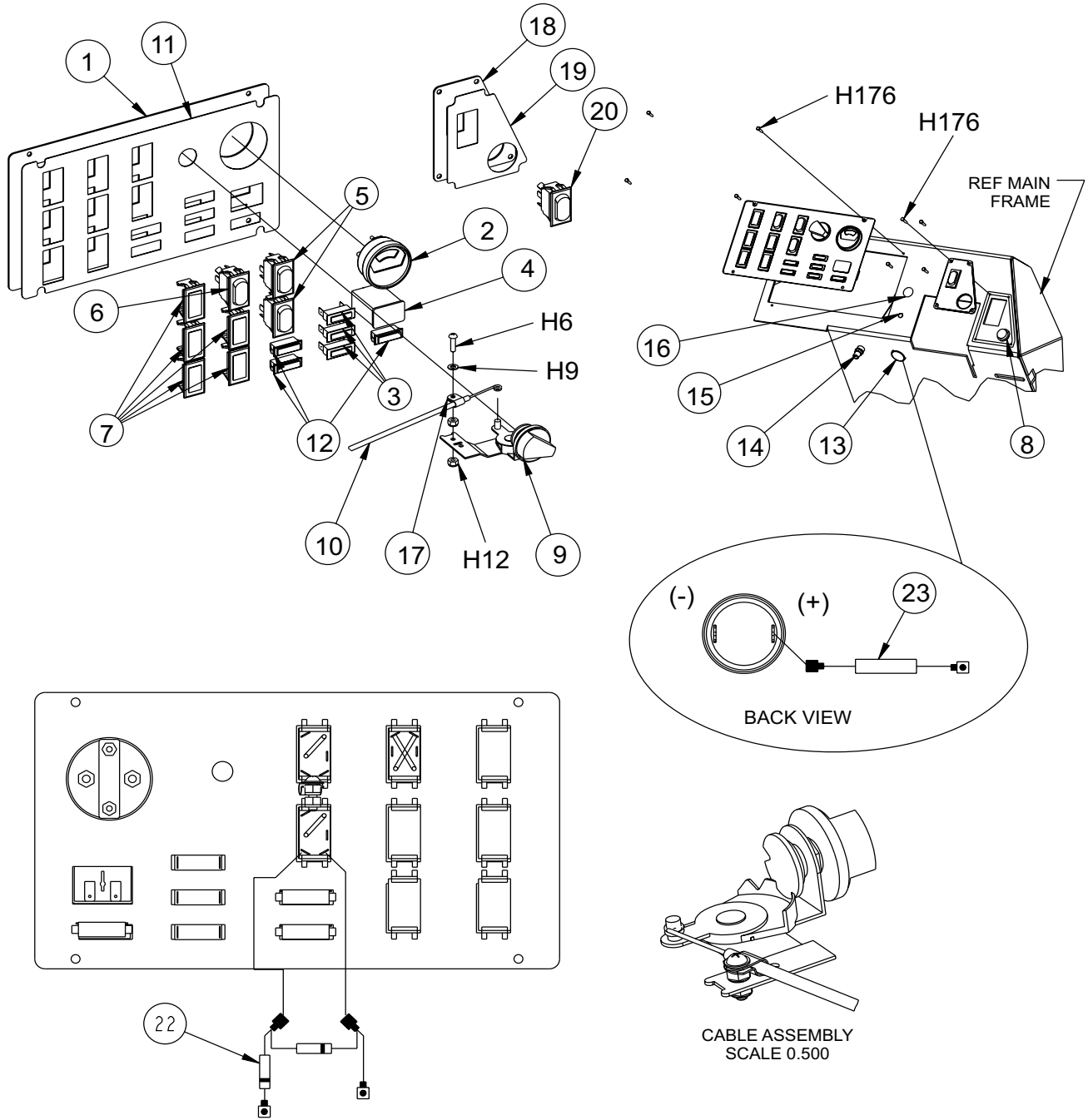

**BACK VIEW OF INSTRUMENTAL PANEL**

\*NOTE: HARNESS 0795-128 NOT SHOWN

## **INSTRUMENT PANEL (12V) - PARTS LIST**

---

<b><u>Key No.</u></b>	<b><u>Part Number</u></b>	<b><u>Description</u></b>	<b><u>Qty.</u></b>
1	7-52-00171	Panel - Instrument	1
2	7-48-05029	Meter - Hour	1
3	7-82-00041	Switch - Double Pole, Triple Throw (ON-ON-ON)	2
4	7-82-00042	Switch - Motor reversing	1
5	2-00-05375	Blank - McGill Switch	5
6	8-82-00041	Key Switch (Ignition)	1
7	7-10-00035	Control - Solution	1
8	7-10-00034	Cable - Solution Control	Ref
9	7-32-09003	Alarm - Chime	1
10	8-82-00030	Switch - Push Button Lid	1
11	7-18-00271	Decal - Instrument Panel (12V)	1
12	8-48-05032	Gauge - Fuel	1
13	7-40-05042	Light - (14V) Amber	2
14	7-40-05028	Light - (14V) Red	3
15	2-00-05418	Blank - Light (Black)	1
15	0795-133	Harness - Instrument Panel	1
16	0775-227	Diode Assembly	1

### **HARDWARE USED:**

H176	2-00-05337	Screw, #8-32 x .750 BHS SS	8
------	------------	----------------------------	---

C1925/0004

# INSTRUMENT PANEL (12V) - EXPLODED VIEW

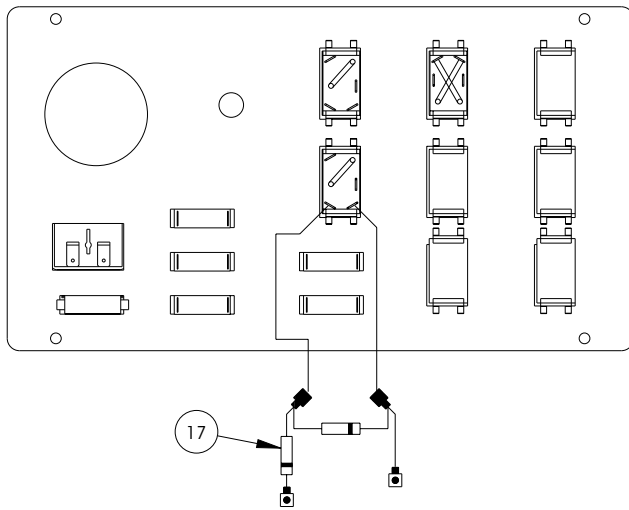
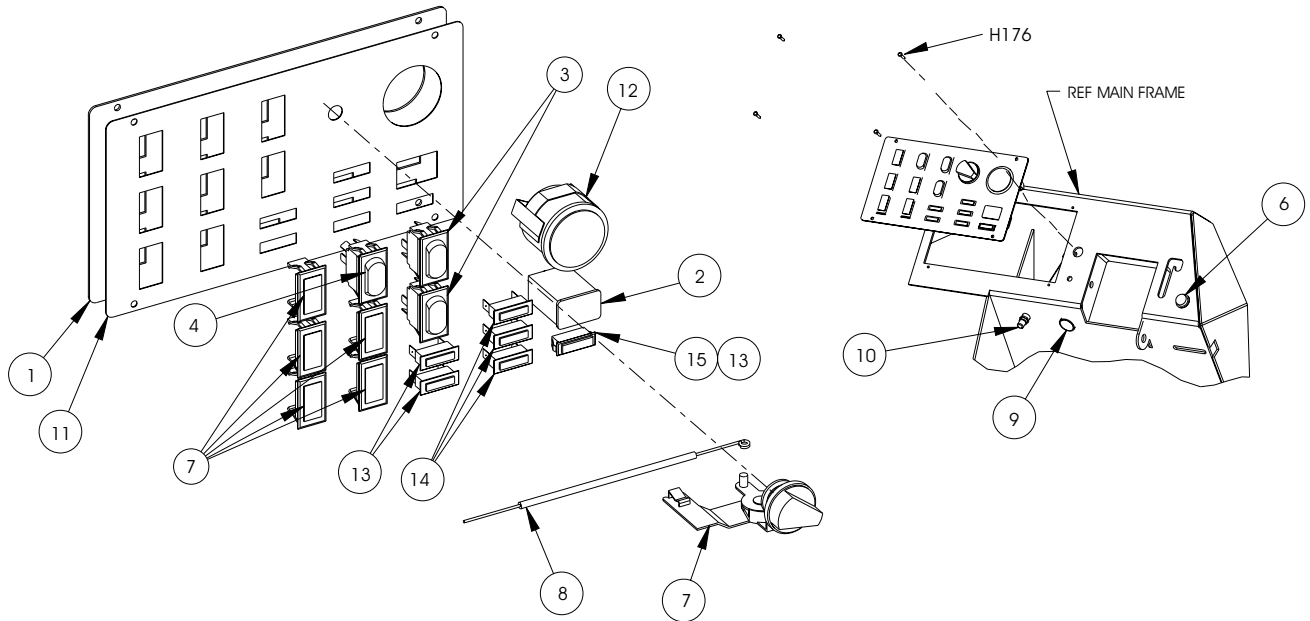

BACK VIEW OF INSTRUMENT PANEL

C1925/9906

## ***DECALS - PARTS LIST***

---

<b><u>Key No.</u></b>	<b><u>Part Number</u></b>	<b><u>Description</u></b>	<b><u>Qty.</u></b>
1	7-18-00236	No Step Decal	2
2	8-18-00396	General Warning Decal	1
3	8-50-00014	Serial Number Tag	1
4	2-00-04115	Rivet	6
5	7-18-00228	Patent Decal	1
6	8-18-00402	Pinch Point Warning Decal	1
7	8-18-00395	Key On/Off Warning Decal	1
8	7-18-00099	Decal - No Combustible Warning	1
9	7-18-00262	Decal - Horn	1
10	8-18-00398	Safety Arm Decal	1
11	8-50-05022	Anti - Skid Pad	3
12	7-50-05136	Anti - Skid Pad	1
13	7-40-00006	"Reverse" Decal	1
14	7-40-00005	"Forward" Decal	1
15	8-18-00313	Seat Adj Decal	1
16	7-18-00272	Main/Side Broom Adj Decal	1
17	7-18-00274	Choke/Throttle Decal	1
18	7-18-00270	Instrument Panel Decal (Battery)	Ref.
*18	7-18-00271	Instrument Panel Decal (IC Engines)	Ref
19	8-18-00306	Hyd Fluid Only Decal	1
20	7-18-00142	Decal - Electrical Hazard	1
*21	8-18-00399	Fan Belt Warning Decal	1
*22	7-18-00276	Diesel Start Decal	1
*23	8-18-00310	Gasoline Only Decal	1
*24	8-18-00311	Diesel Only Decal	1
*25	8-18-00085	Fire Hazard Decal	1
26	7-29-00259	Edging	1
27	7-18-00279	Decal - Broom Lift Switch	Ref.

\*Gas, LP and Diesel Only

C1914/0101

**DECALS - EXPLODED VIEW**

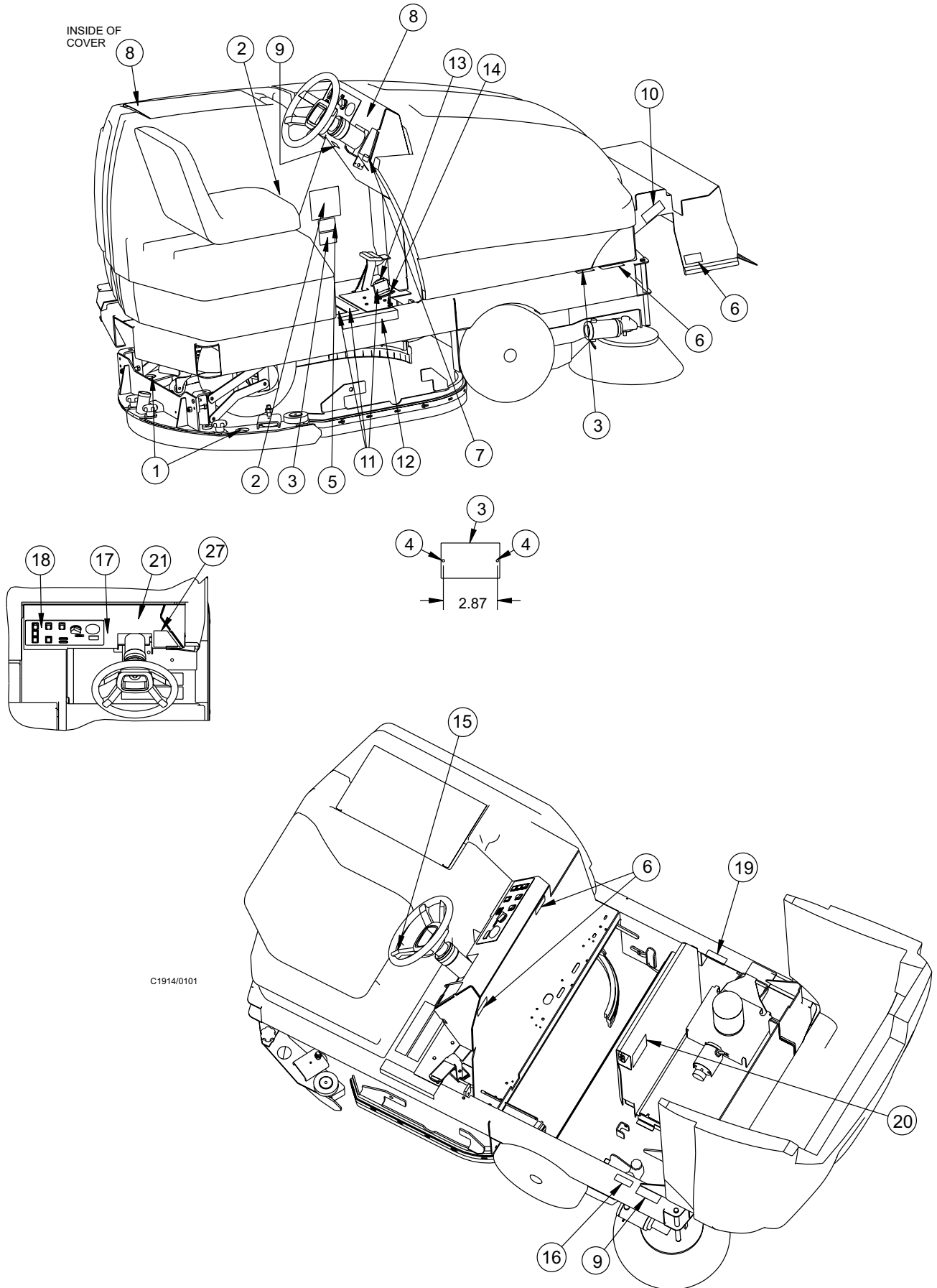



## CHAPTER 3 TABLE OF CONTENTS

---

Back-Up Alarm (12V & 36V) .....	3-2
Battery Stand .....	3-3
ESP (12V & 36V) .....	3-4
Fire Extinguisher .....	3-7
Light Package .....	3-8
Over Head Guard (OHG) .....	3-9
Strobe Light Without OHG (12 & 36 VDC) .....	3-10
Strobe Light With OHG (12 & 36 VDC) .....	3-12
Seat Belt Assembly .....	3-14
Squeegee Wand .....	3-15
Pad Driver (20") .....	3-16
Spray & Vac Wand (12V & 36V) .....	3-17
Hydraulic Kit .....	3-21
Scrub Brush Assy w/ OptionalBrushes .....	3-22
Spare Parts Kit .....	3-23
Index .....	3-24
Warranty .....	3-27

# BACK - UP ALARM (12V & 36V)

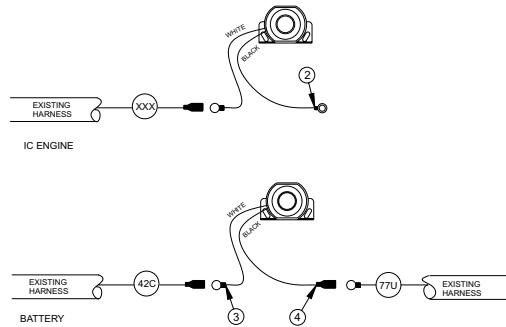
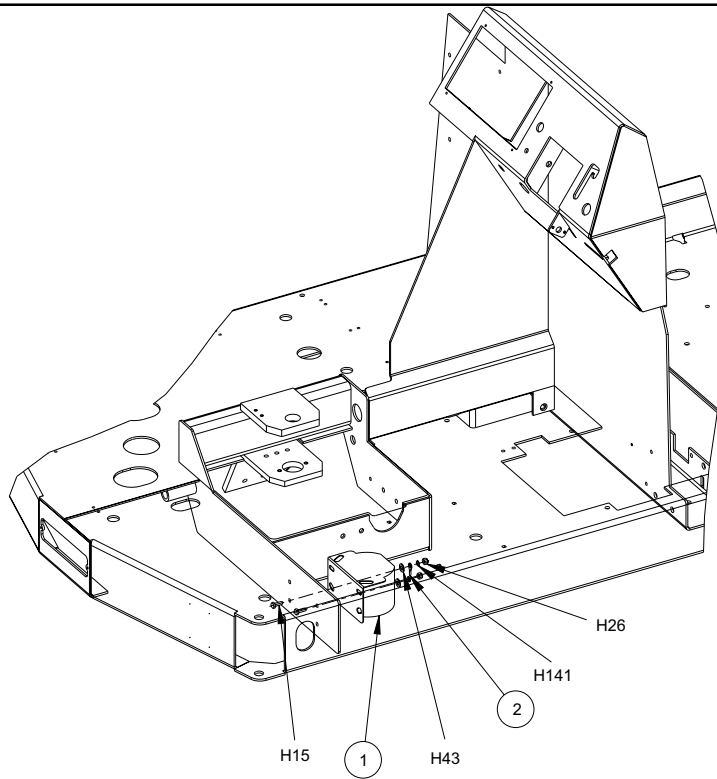

C19429958

Key No.	Part Number	Description	Qty.
1	8-32-09009	Back Up Alarm (9.8 to 56.4 VDC)	1
2	2-00-00828	Ring Terminal	1
3	2-00-04578	Terminal (.156 Male Bullet)	1
4	2-00-00828	Terminal (.156 Female Bullet)	1

### HARDWARE USED:

H15	2-00-00221	Screw, 1/4 - 20 x .750 HHC	2
H26	2-00-00641	Nut, 1/4 - 20 Insert Fiber	2
H43	2-00-00409	Flat Washer, .687 x .344 x .062	2
H141	2-00-00501	Lock Washer, Int.	2

C1942/0012

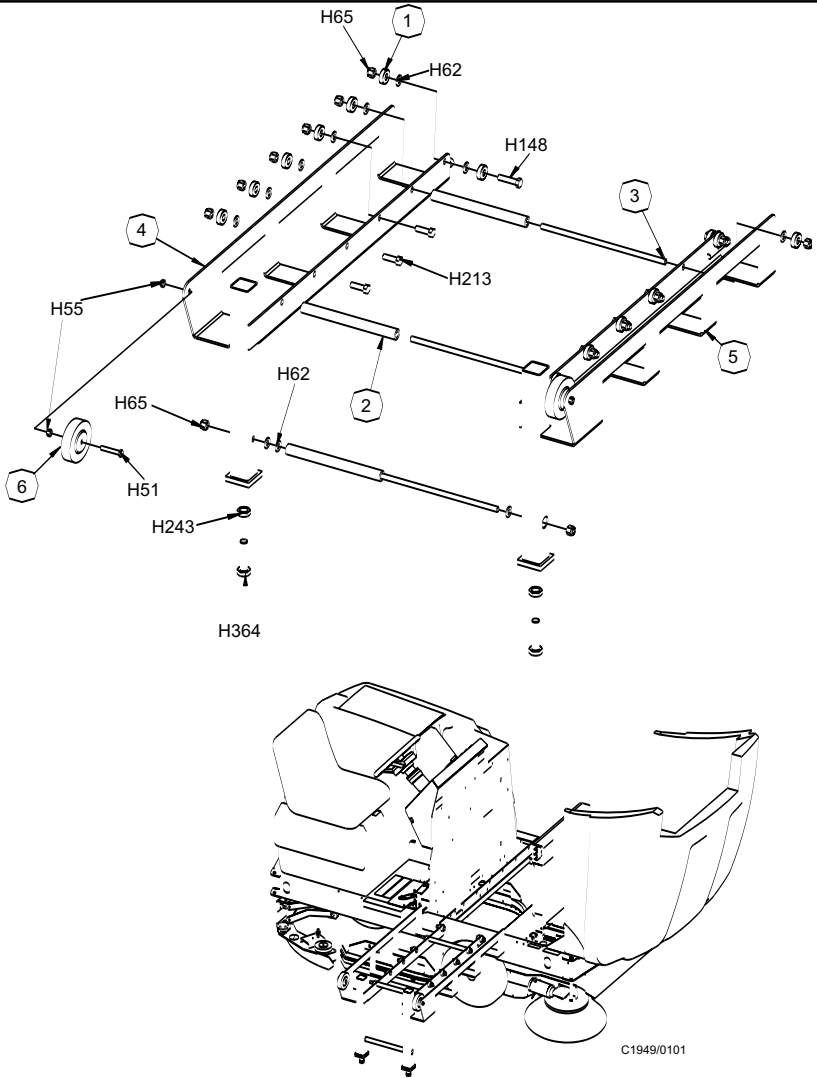

<u>Key No.</u>	<u>Part Number</u>	<u>Description</u>	<u>Qty.</u>
1	2-00-03306	Bearing Ball	14
2	7-75-01201	Spacer - Battery Stand	3
3	7-80-05088	Stud - Battery Stand	3
4	7-81-00228	Support - Battery Stand	1
5	7-81-00227	Support Battery Stand	1
6	2-14-00184	Wheel	2

**HARDWARE USED:**

H51	2-00-00216	Screw, 3/8-16 x 2.000 HHC	2
H55	2-00-00643	Nut, 3/8-16 Stop	4
H62	2-00-00405	Flat Washer, 1.063 x .531 x .094	17
H65	2-00-04936	Nut, 1/2-13 Fibre Lock	14
H148	2-00-01778	Screw, 1/2-13 x 2.000 HHC	2
H213	2-00-01254	Screw, 1/2-13 x 1.500 HHCS	6
H364	2-00-02694	Screw - HHC .50-20 x 2.25	2

C1949/0101

## **ESP RECOVERY OPTION - PARTS LIST**

---

<b><u>Key No.</u></b>	<b><u>Part Number</u></b>	<b><u>Description</u></b>	<b><u>Qty.</u></b>
1	7-60-05025	Pump - Recycling (12 VDC) (IC Engine)	1
1	7-60-05013	Pump - Recycling (36 VDC) (Battery)	1
2	7-25-02062	Fitting - Reduced Nipple	1
3	2-00-02061	Fitting	2
4	2-00-03407	Hose Clamp - Witteck #10P	4
5	7-25-02436	Hose, Pump to Tank	1
6	2-00-05131	Fitting - Nipple	2
7	2-00-05132	Fitting - Elbow	2
8	2-00-05083	Fitting - 90° ¾ NPT Elbow	1
9	2-00-04736	Pipe Connector	1
10	7-24-04038	Filter - Pump Inlet	1
11	7-33-02329	Hose, Tank to Pump	1
12	7-09-01146	Bushing - Bulkhead Fitting	1
13	8-82-00059	Switch - Rocker (SPST)	1
14	8-11-00015	Terminal (.25 Male Fiso)	1
15	2-00-03418	Terminal (.25 Female Fiso)	1

### **HARDWARE USED:**

H8	2-00-00039	Screw, 10-24 x 1.000 RHM	4
H9	2-00-00426	Flat Washer, .500 x .219 x .063	4
H12	2-00-01246	Nut, Hex Fiber Insert #10-24	4
H20	2-00-00203	Screw, 1/4-20 x 1.500 HHC	1
H26	2-00-00641	Nut, 1/4-20 Insert Fiber	1
H247	2-00-04590	Washer	2
H248	2-00-05236	Flatwasher, 2.000 x .281 x .063	2
H332	2-00-05028	Washer - Neoprene, 2.000 x .250 x .130	2

C1944/0008

# ESP RECOVERY OPTION - EXPLODED VIEW

REMOVE WIRES 23 AND 28B FROM HIGH REC SW AND PLUG INTO ESP FLOAT SE AS SHOWN

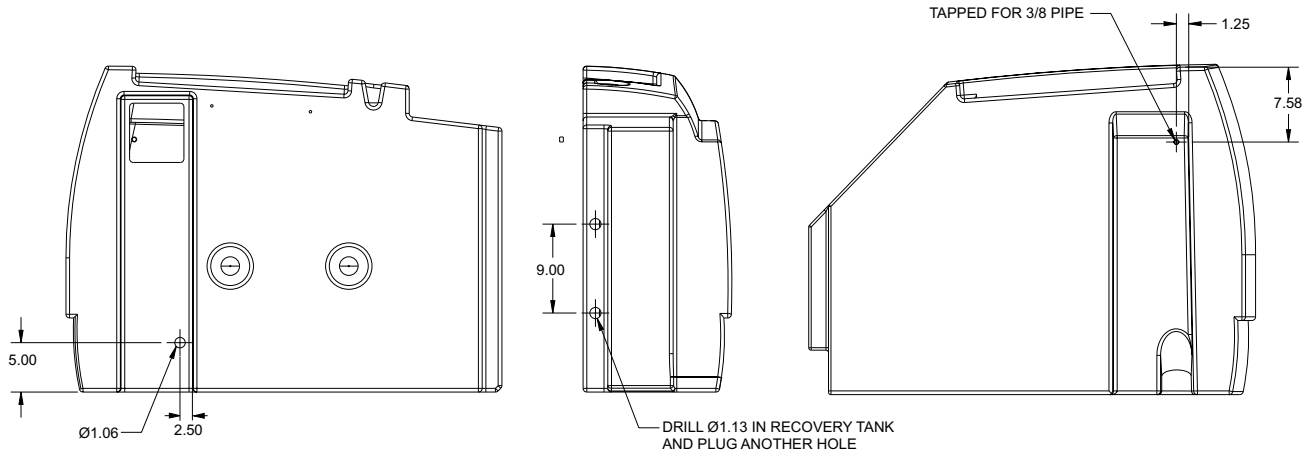
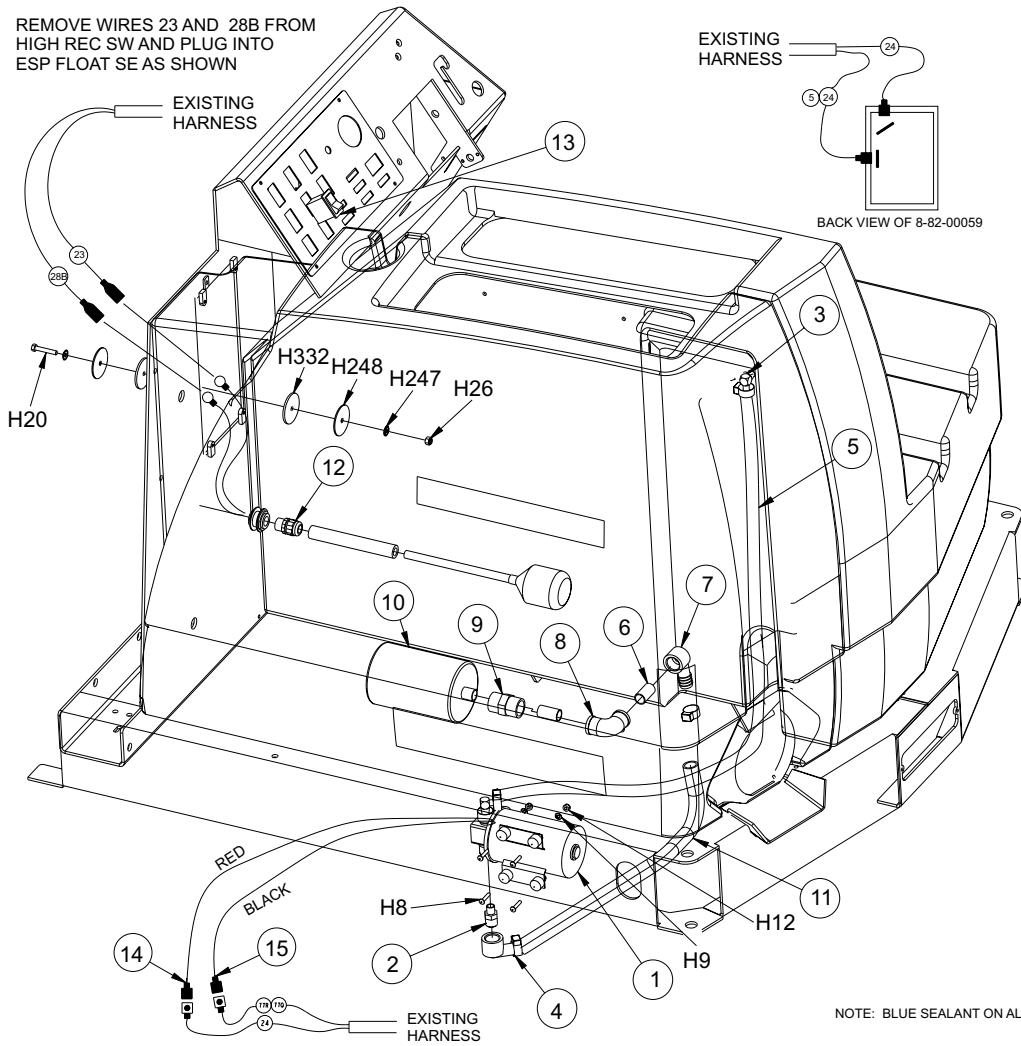

C1944/0008

# ESP RECOVERY OPTION

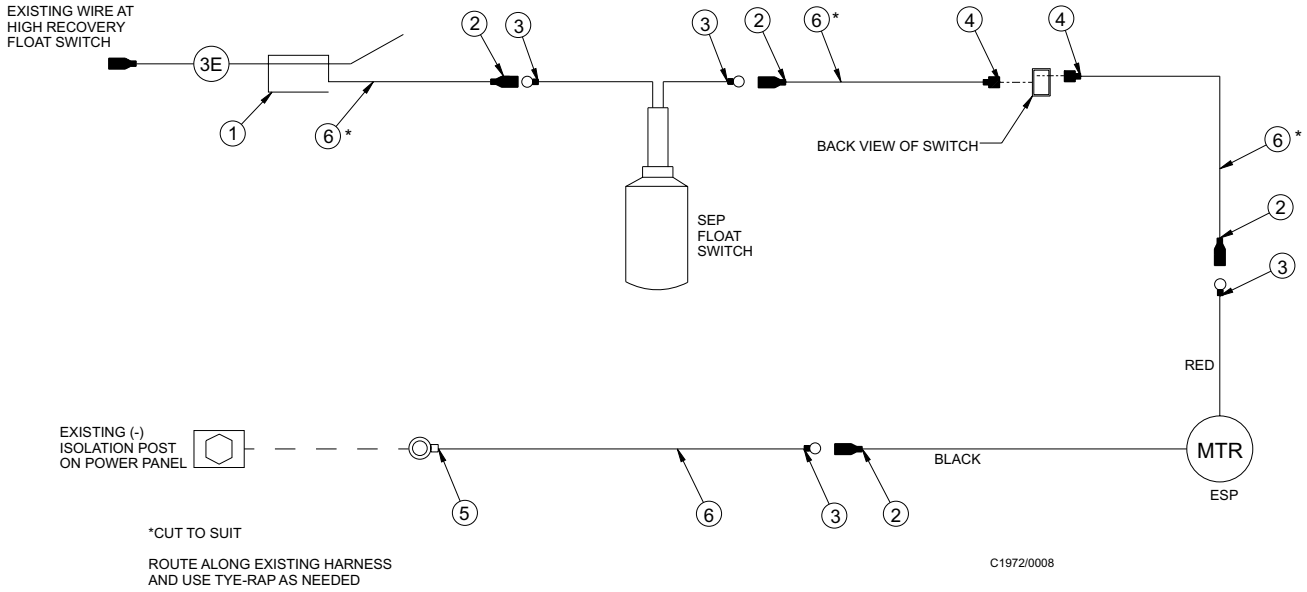

Key No.	Part Number	Description	Qty.
1	2-00-04479	Terminal - 3 way	1
2	2-00-04626	Terminal - .156 Fem Bullet	4
3	2-00-04578	Terminal - .156 Male Bullet	4
4	2-00-03418	Terminal - .25 Fiso Fem	2
5	2-00-04284	Terminal - Ring	2
6	3-61-00189	Wire - 16 AWG Black	15"

C1972/0008

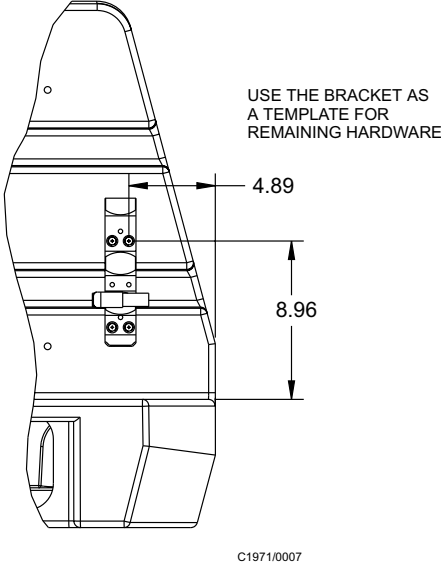
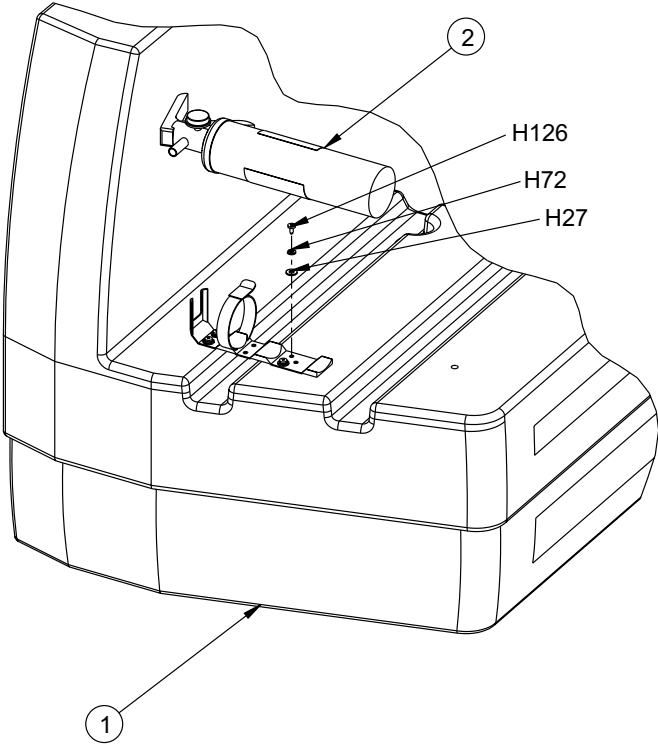

<u>Key No.</u>	<u>Part Number</u>	<u>Description</u>	<u>Qty.</u>
1	7-83-04179-1	Solution Tank	Ref.
2	8-83-04033	Fire Extinguisher 2 1/2 lb.	1

**HARDWARE USED:**

H27	2-00-03702	Washer, .625 x .281 x .063	4
H72	2-00-00518	Lock Washer, Helical Spring	4
H126	2-00-03466	Screw, #10-16 x .500	4

C1971/0007

# LIGHT PACKAGE

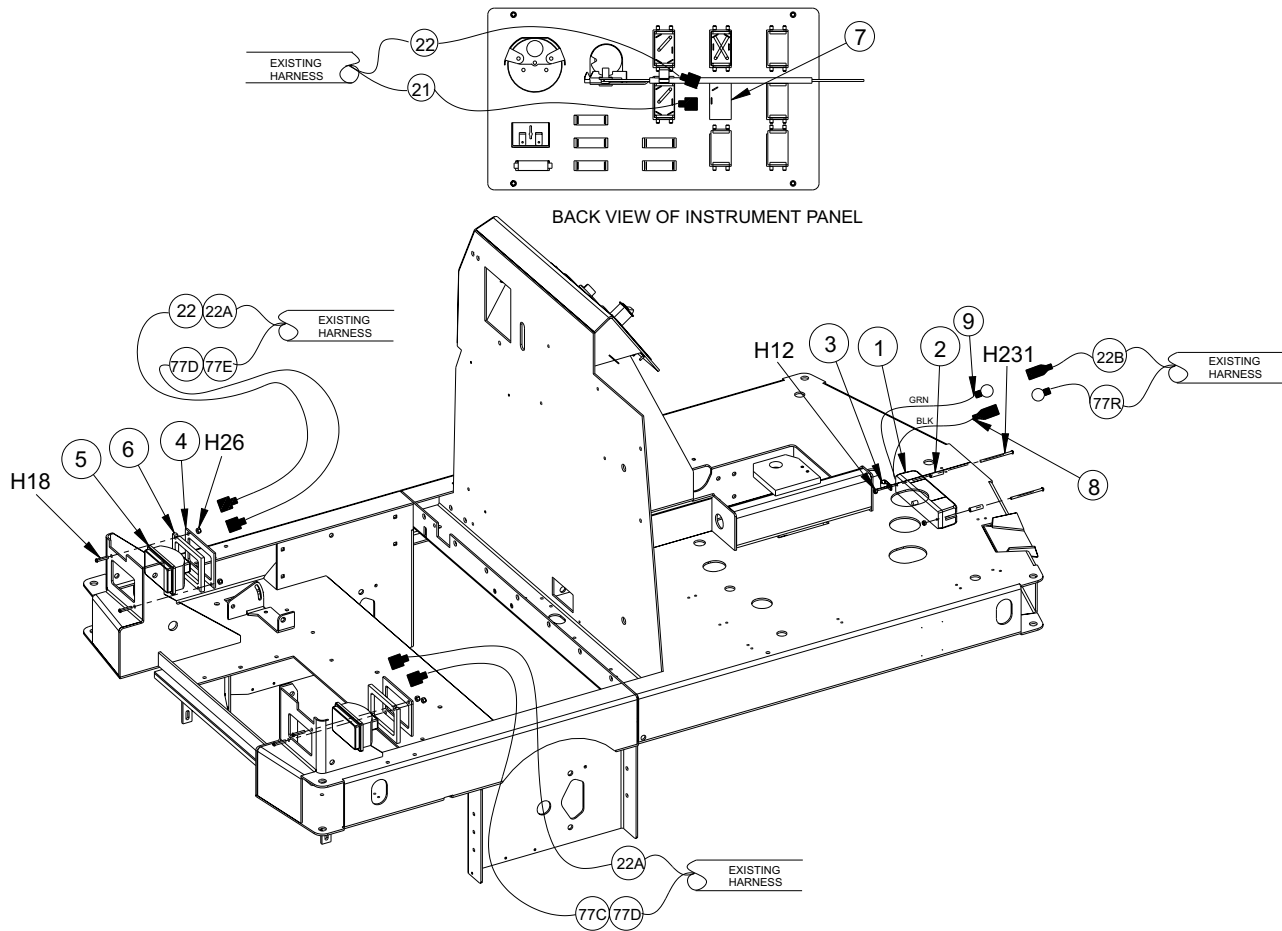

C1947/9906

<u>Key No.</u>	<u>Part Number</u>	<u>Description</u>	<u>Qty.</u>
*1	8-40-05044	Tail Light (12V)	1
*1	8-40-05053	Tail Light (36V)	1
2	8-75-01207	Spacer - Tail light MTG	2
3	2-00-04210	Clamp	1
4	7-08-00557	Bracket - Light	2
*5	7-40-05034	Head Light (12V)	2
*5	7-40-05031	Head Light (36V)	2
6	7-29-00191	Gasket - Light	2
7	8-82-00059	Switch (SPST)	1
8	2-00-04626	Terminal (.156 Female Bullet)	1
9	2-00-04578	Terminal (.156 Male Bullet)	1

\*Use 12V lights on IC Engines and 36V lights on the Battery version

## HARDWARE USED:

H12	2-00-01246	Nut, Hex Fiber Insert #10-24	2
H18	2-00-00060	Screw, ¼-20 x 1.250 RHM	4
H26	2-00-00641	Nut, ¼-20 Insert Fiber	4
H231	2-00-02933	Screw, Mach 10-24 x 3.50	2

C1947/0008

**OVERHEAD GUARD (OHG)**

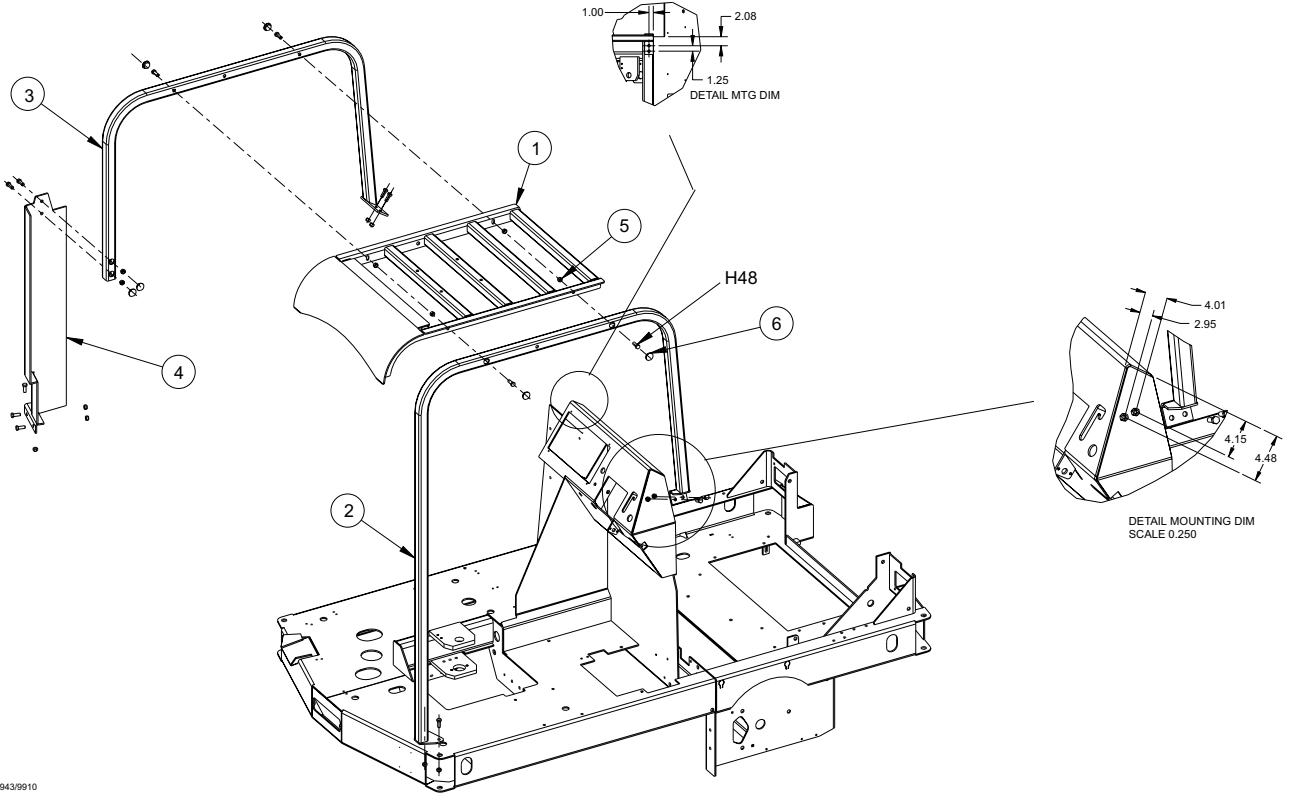

C1943/9910

<u>Key No.</u>	<u>Part Number</u>	<u>Description</u>	<u>Qty.</u>
1	8-30-05174	Overhead Guard - Top Weldment	1
2	8-81-00181	Support - RH OHG (Welded)	1
3	8-81-00182	Support - LH OHG Upper Weldment	1
4	8-81-00183	Support LH Lower OHG Weldment	1
5	2-95-04182	Nut - 3/8-16 Elastic Stop Nut	15
6	2-00-05134	Plug Button	6

**HARDWARE USED:**

H48	2-00-00233	Screw, 3/8-16 x 1.000 HHC	15
-----	------------	---------------------------	----

C1943/9910

## **STROBE LIGHT W/O OHG (12 & 36 VDC) - PARTS LIST**

---

<b><u>Key No.</u></b>	<b><u>Part Number</u></b>	<b><u>Description</u></b>	<b><u>Qty.</u></b>
1	7-81-00223	Support - Warning Light	1
2	3-61-02014	Convolute Tube (6 ft.)	1
3	2-00-03261	Grommet	1
4	2-00-00491	Grommet	1
5	8-40-05020	Red Strobe Light (12 to 80 VDC)	1
5	8-40-05036	Amber Strobe Light (12 to 80 VDC)	1
*6	3-61-00193	Wire - 16 GA (Red)	10 ft.
*7	3-61-00189	Wire - 16 GA (Black)	10 ft.
8	2-00-04578	Terminal (.156 Male Bullet)	2
9	2-00-04626	Terminal (.156 Female Bullet)	2
10	2-00-04479	Terminal (3-way)	1
11	2-00-04281	Terminal (#10 Ring) (Only used on IC Engines)	1

\*Cut to Suit

### **HARDWARE USED:**

H11	2-00-00605	Nut, Hex MS #10-24 x .375 x .125	2
H48	2-00-00233	Screw, 3/8-16 x 1.000 HHC	4
H52	2-00-00402	Flat Washer, .750 x .390 x .094	8
H53	2-00-02310	Lock Washer, Helical Spring 3/8 Med.	4
H54	2-00-02360	Nut, 3/8-16 Hex.	4
H115	2-00-03063	Screw, #10-24 x .750 THM	2
H159	2-00-00512	Lock Washer	2

C1945/9906

**STROBE LIGHT W/O OHG (12 & 36 VDC) - EXPLODED VIEW**

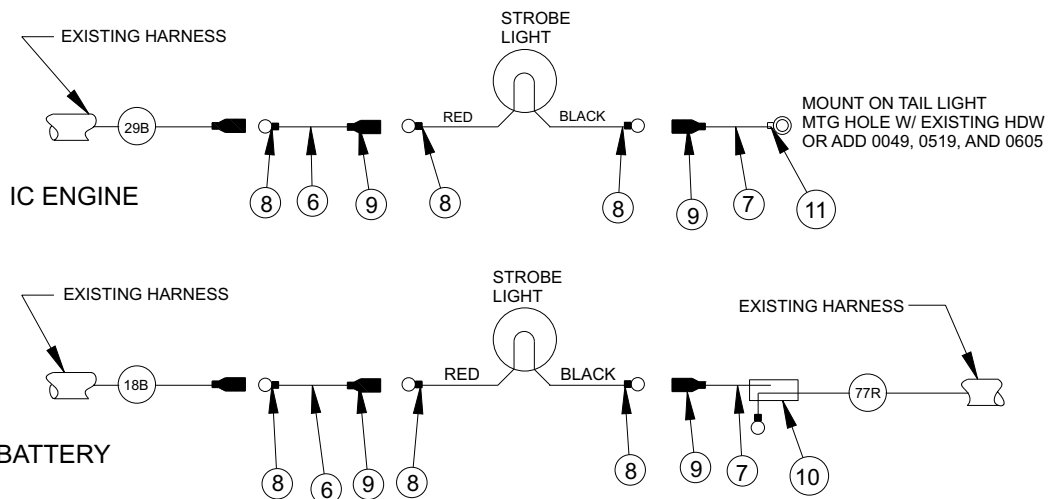
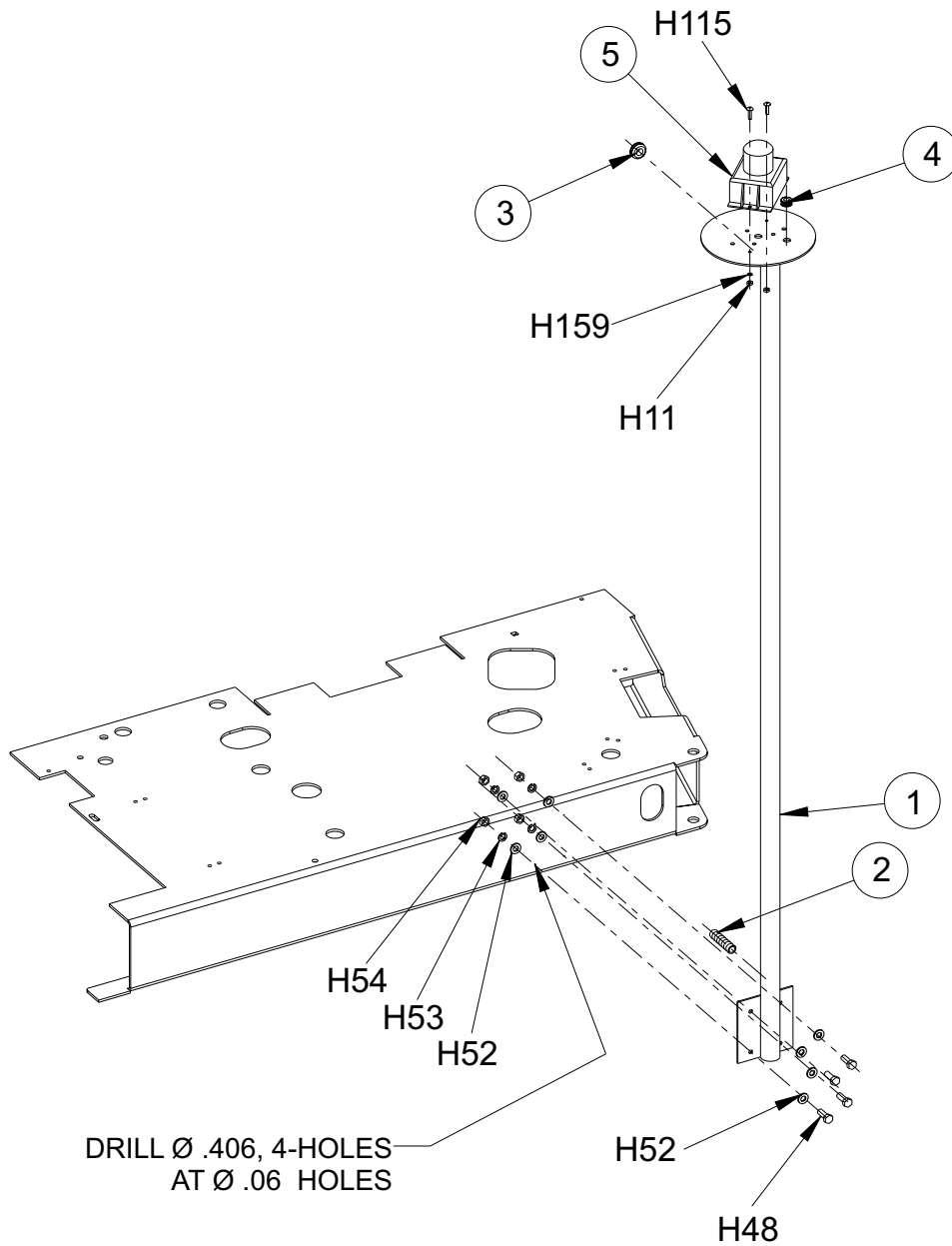

## STROBE LIGHT W/ OHG (12 & 36 VDC) - PARTS LIST

---

<u>Key No.</u>	<u>Part Number</u>	<u>Description</u>	<u>Qty.</u>
1	8-58-05228	Plate - Flasher Mounting	1
2	3-61-02014	Convuluted Tube (6 ft.)	1
3	2-00-04578	Terminal (.156 Male Bullet)	2
4	8-40-05020	Red Strobe Light (12 to 80 VDC)	1
4	8-40-05036	Amber Strobe Light (12 to 80 VDC)	1
5	2-00-04345	Ty - Rap	4
*6	3-61-00193	Wire 16 GA (Red)	10 ft.
*7	3-61-00189	Wire 16 GA (Black)	10 ft.
8	2-00-04626	Terminal (.156 Female Bullet)	2
9	2-00-04479	Terminal (3-way)	1
10	2-00-04281	Terminal (#10 Ring) (Only used on IC Engines)	1

\*Cut to Suit

### HARDWARE USED:

H11	2-00-00605	Nut, Hex MS #10-24 x .375 x .125	2
H15	2-00-00221	Screw, ¼ - 20 x .750 HHC	4
H72	2-00-00518	Lock Washer, Helical Spring	4
H115	2-00-03063	Screw #10-24 x .750 THM	2
H159	2-00-00512	Lock Washer	2

C1946/9906

**STROBE LIGHT W/ OHG (RED 12 & 36 VDC) - EXPLODED VIEW**

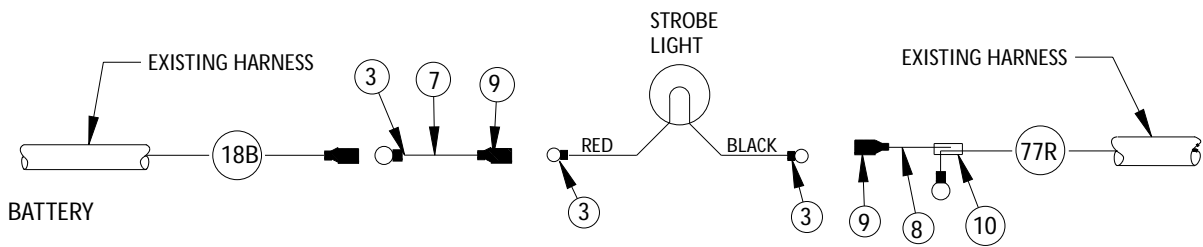
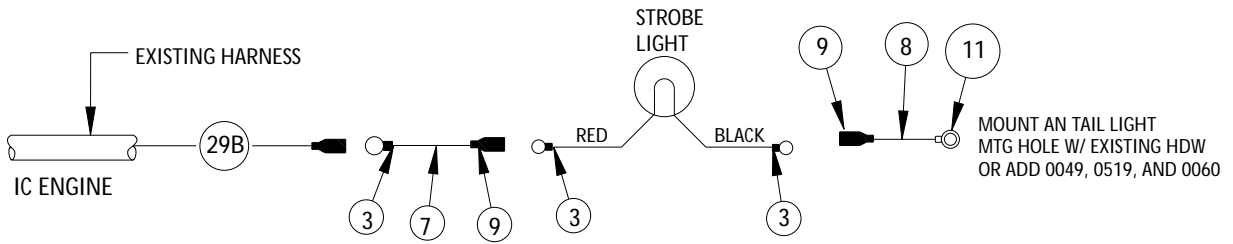
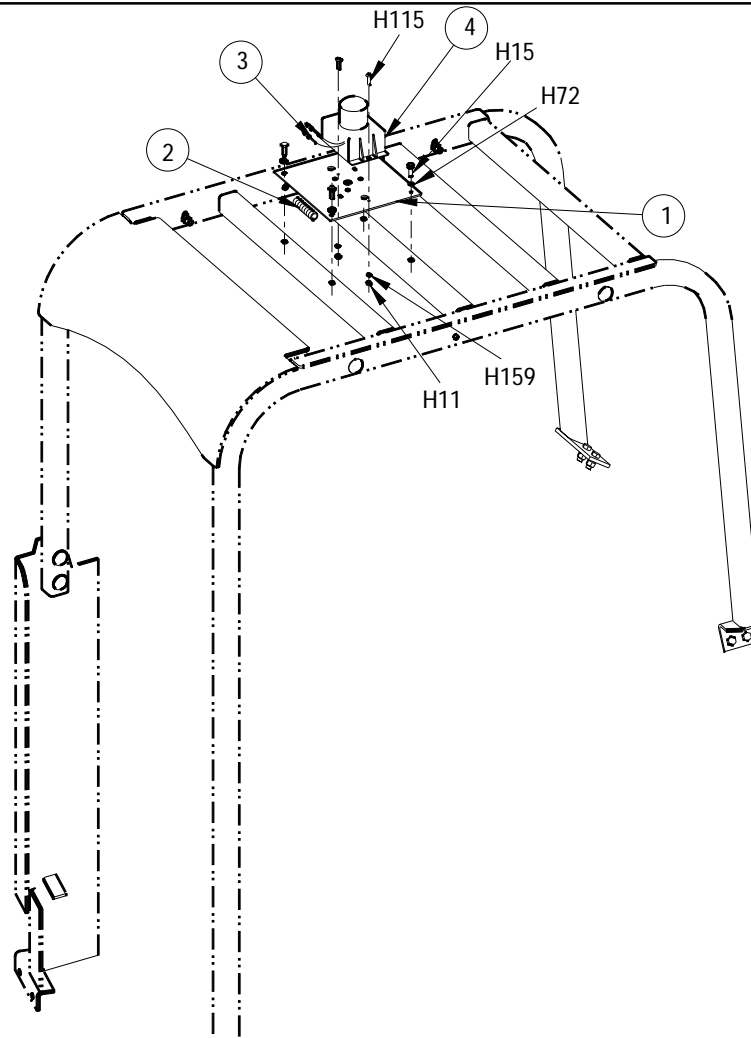

# SEAT BELT ASSEMBLY

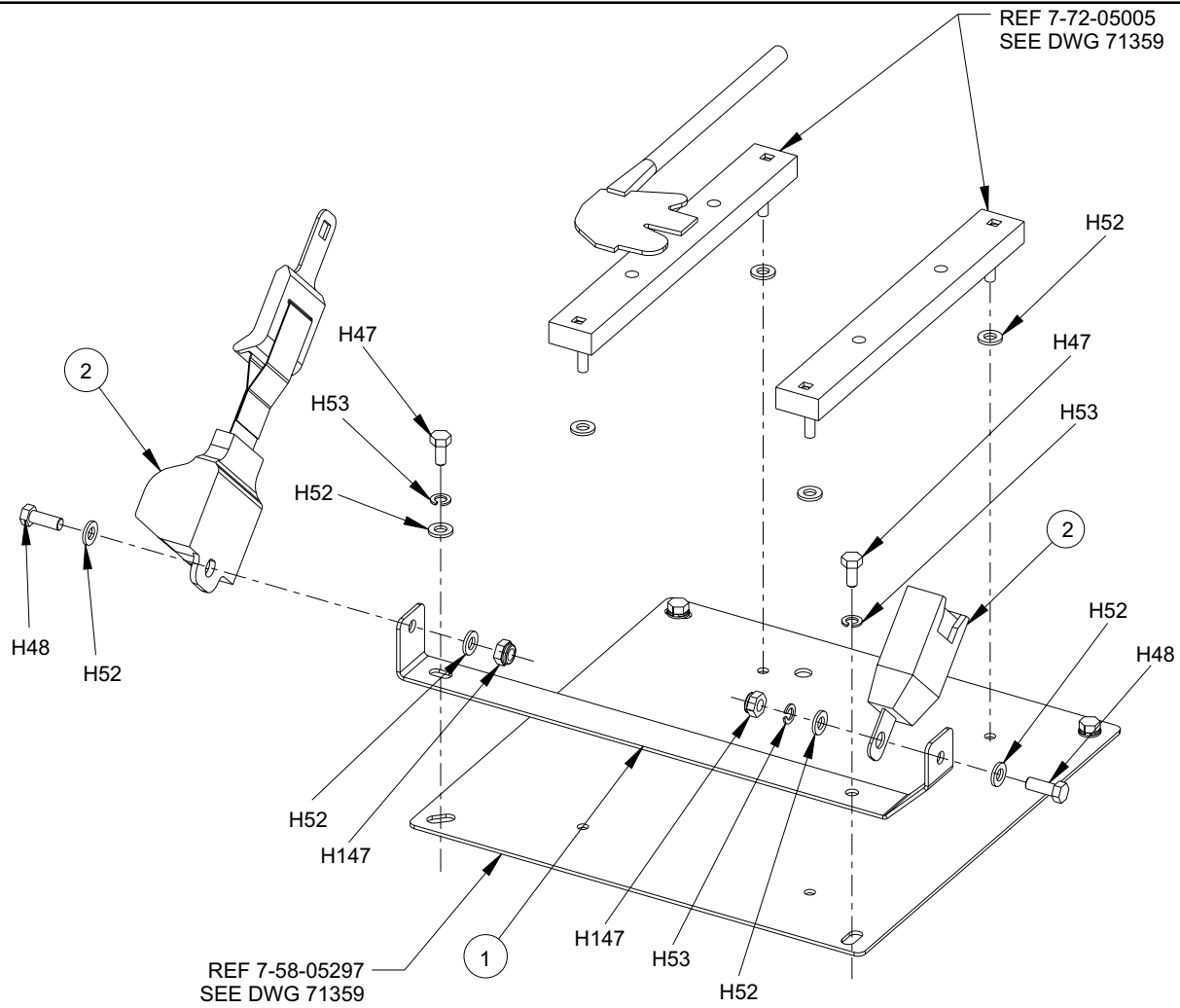

C1950/9907

<u>Key No.</u>	<u>Part Number</u>	<u>Description</u>	<u>Qty.</u>
1	7-08-00973	Bracket - Seat Belt	1
2	2-00-05391	Retractable Seat Belt	1

HARDWARE USED:

H47	2-00-00232	Screw, 3/8-16 x .750 HHC	REF
H48	2-00-00233	Screw, 3/8-16 x 1.000 HHC	2
H52	2-00-00402	Flat Washer, .750 x .390 x .094	9
H53	2-00-02310	Lock Washer, Helical Spring 3/8 Med.	3
H55	2-00-00643	Nut, 3/8-16 Stop	2

C1950/9907

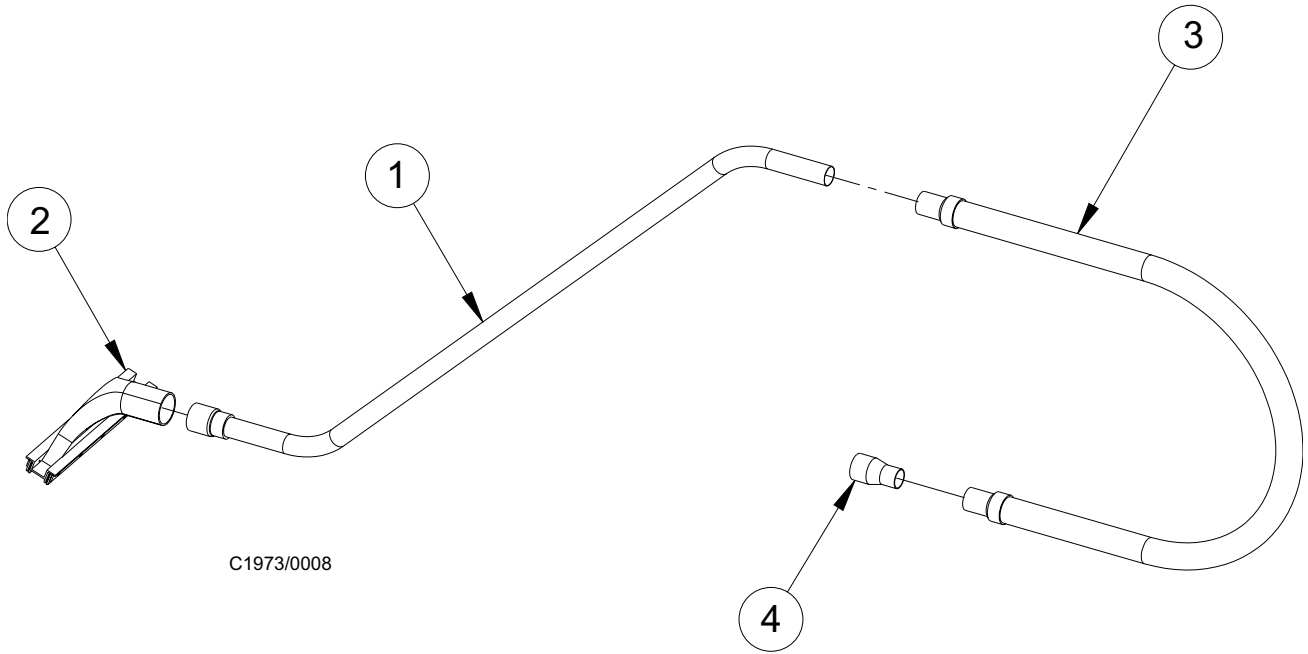

C1973/0008

Key No.	Part Number	Description	Qty.
1	0261-025	Wand Assembly	1
2	0261-024	Tool Assembly	1
3	7-33-02213	Hose - Vac	1
4	7-03-00044	Adapter - Transition	1

C1973/0008

**PAD DRIVER (20")**

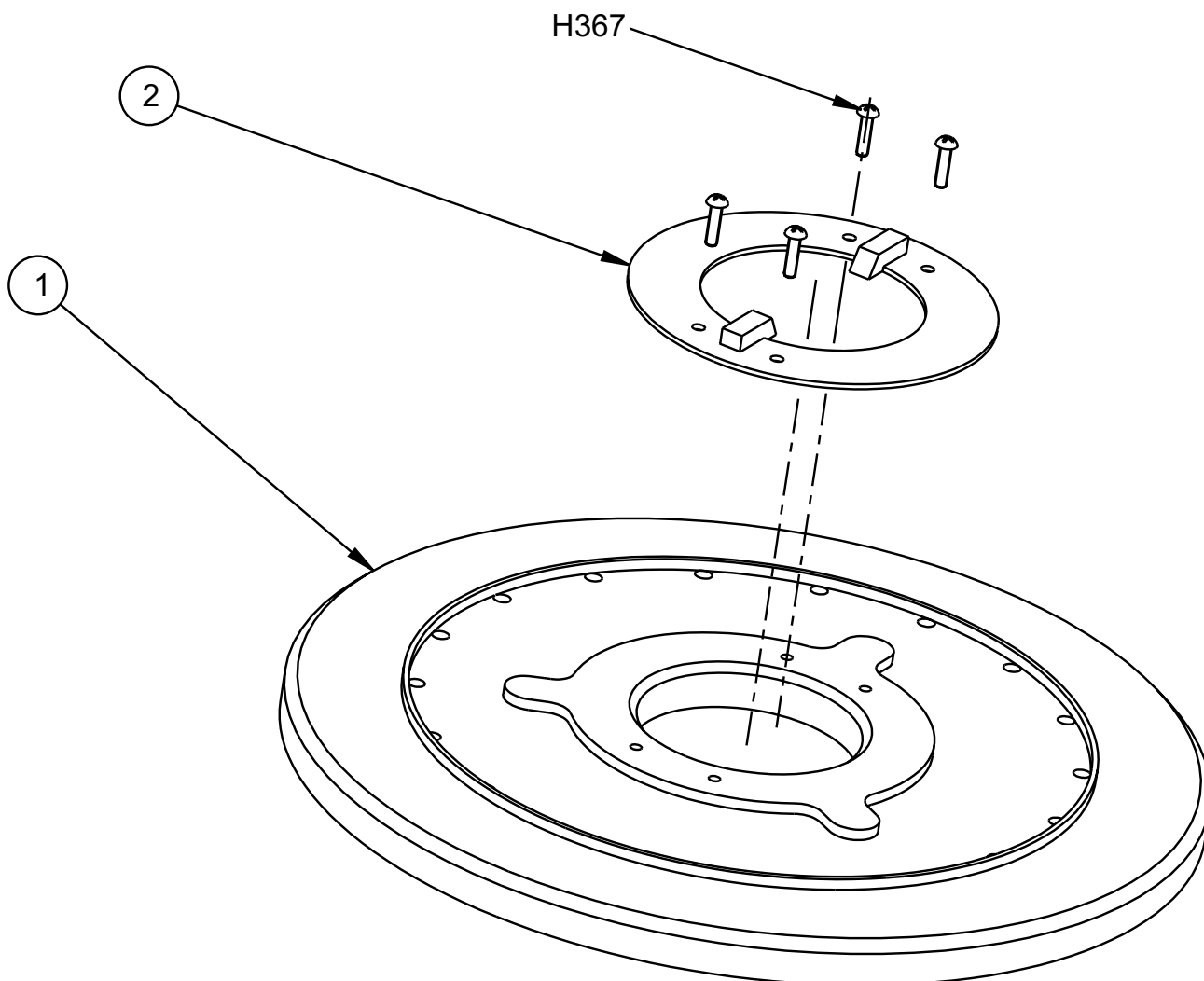

<u>Key No.</u>	<u>Part Number</u>	<u>Description</u>	<u>Qty.</u>
1	7-20-00013	Driver - 20" Dia. Pad	1
2	7-19-02035	Disc - Brush Driver	1

**HARDWARE USED:**

H367	2-00-00081	Screw, Ph. Rhm .25-20 x 1.000 Zn	4
------	------------	----------------------------------	---

C1921/0007

## SPRAY & VAC WAND (12V & 36V)

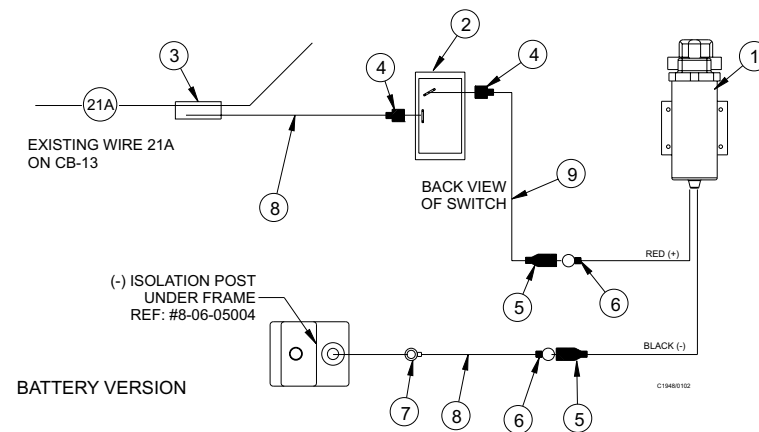
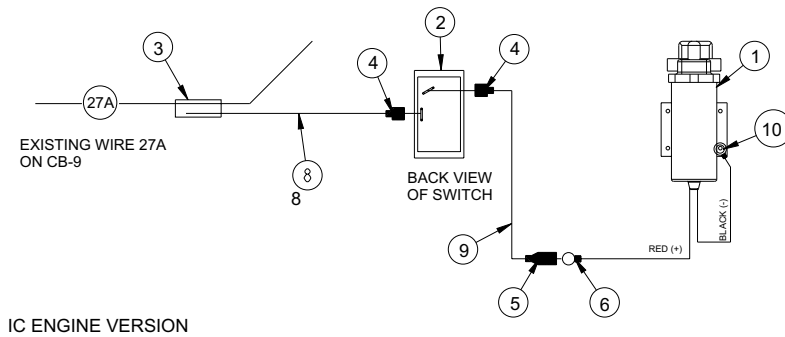

<u>Key No.</u>	<u>Part Number</u>	<u>Description</u>	<u>Qty.</u>
*1	7-60-05022	Pump - Water 12 VDC (IC Engine Only)	Ref.
*1	7-60-05017	Pump - Water 36 VDC (Battery Only)	Ref.
2	8-82-00059	Switch - Rocker (SPST)	Ref.
3	2-00-04479	Terminal - 3-way	1
4	2-00-03418	Terminal - .25 Fiso Female	2
5	2-00-04626	Terminal - .156 Female Bullet	2
6	2-00-04578	Terminal - .156 Male Bullet	2
7	2-00-00828	Terminal - .25 Ring	1
**8	3-61-00189	Wire 16 AWG Black	10 ft.
**9	3-61-00193	Wire 16 AWG Red	10 ft.
***10	2-00-04281	Terminal (#10 Ring) (Used only on IC Engines)	1

\*Use 36v pump on Battery version and 12v pump on IC engines

\*\*Cut to Suit

\*\*\*Terminal only used on IC Engines

**SPRAY & VAC WAND (12V & 36V) (cont.) - PARTS LIST**

---

<u>Key No.</u>	<u>Part Number</u>	<u>Description</u>	<u>Qty.</u>
1	7-08-00769	Bracket - Hose Connection	1
2	2-00-05465	Adapter, 1/4 Female x 1/8 Male	1
3	2-00-05464	Elbow 1/4 NPT x Barb Fitting 3/8	1
4	7-16-05028	Coupling - Quick Disconnect	1
5	2-00-05363	Hose Clamp	4
6	7-60-05017	Pump - Water 36VDC	
6	7-60-05022	Pump - Water 12 VDC (Used on IC Engine)	1
7	2-00-05201	Fitting - Str. 1/2 NPT x 3/8 Barb	2
8	7-25-02012	Fitting - 3/4 I.D. Hose Str Barb	1
9	7-25-02037	Fitting - Plastic (Tee)	1
10	2-00-04655	Fitting - 90° Elbow (Nylon)	1
11	7-25-02053	90° Elbow (3/4 NPT to 3/4 BARB)	1
12	2-00-03407	Hose Clamp - Witteck #10P	3
13	8-82-00059	Switch - Rocker (SPST)	1
14	7-18-00278	Decal - Vac Wand	1
15	3-71-00081	Hose, Pump to Spray	35.50"
16	3-71-03025	Hose, Tank to Tee	2.75"
17	3-71-00081	Hose, Pump to Spray	30.00"

**HARDWARE USED:**

H12	2-00-01246	Nut, Hex Fiber Insert #10-24	4
H15	2-00-00221	Screw, 1/4-20 x .750 HHC	1
H25	2-00-00594	Nut, Hex 1/4-20 x .437 x .218	1
H72	2-00-00518	Lockwasher, Helical Spring	1
H116	2-00-01951	Carriage Bolt, 1/4-20 x 1.250	4
H189	2-00-00460	Flatwasher, .437 x .192 x .031 - s	4
H281	2-00-00415	Flatwasher, .9375 x .468 x .0625 Stl	2

C1952/0102

**SPRAY & VAC WAND (12V & 36V) (cont.) - EXPLODED VIEW**

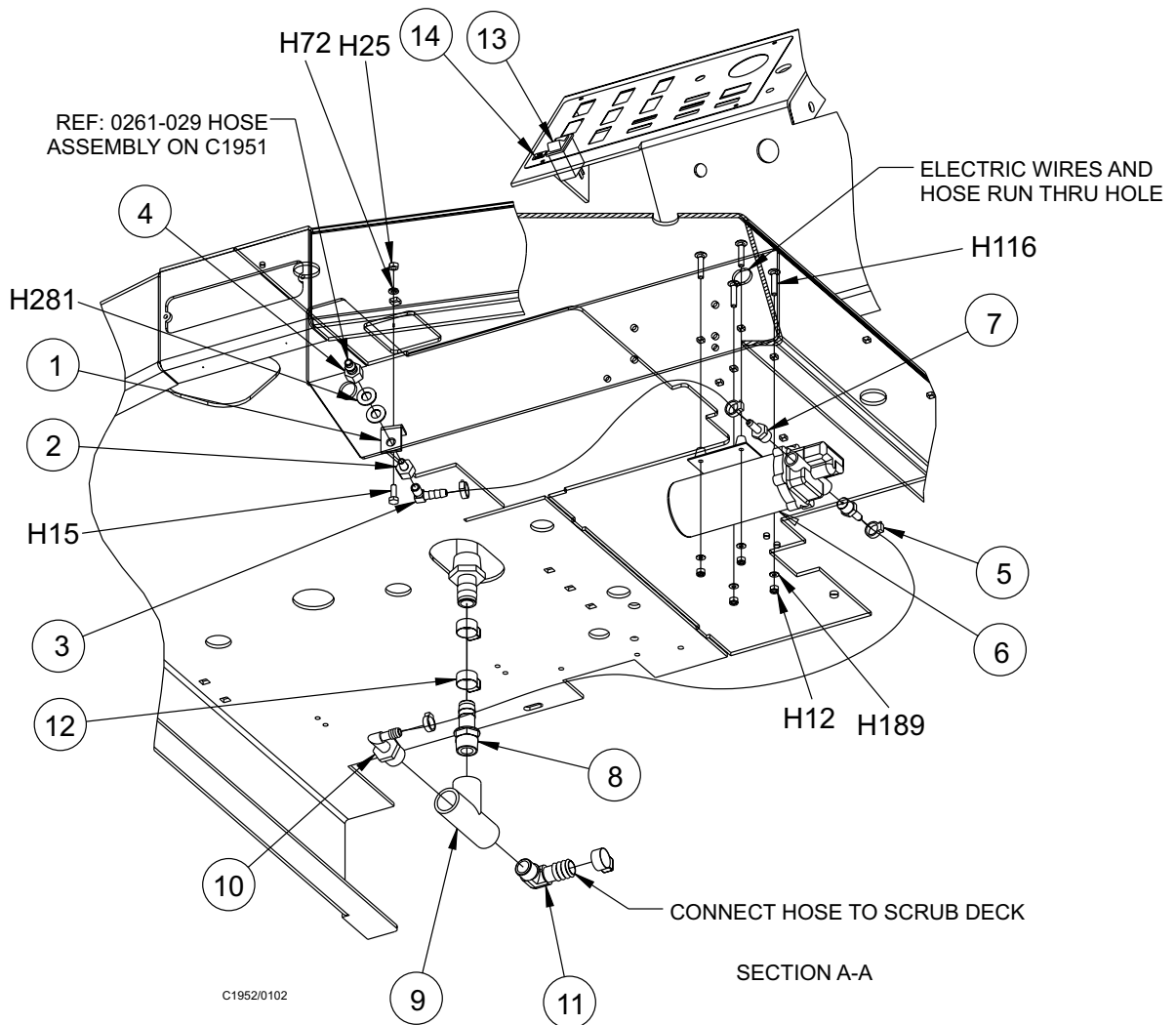
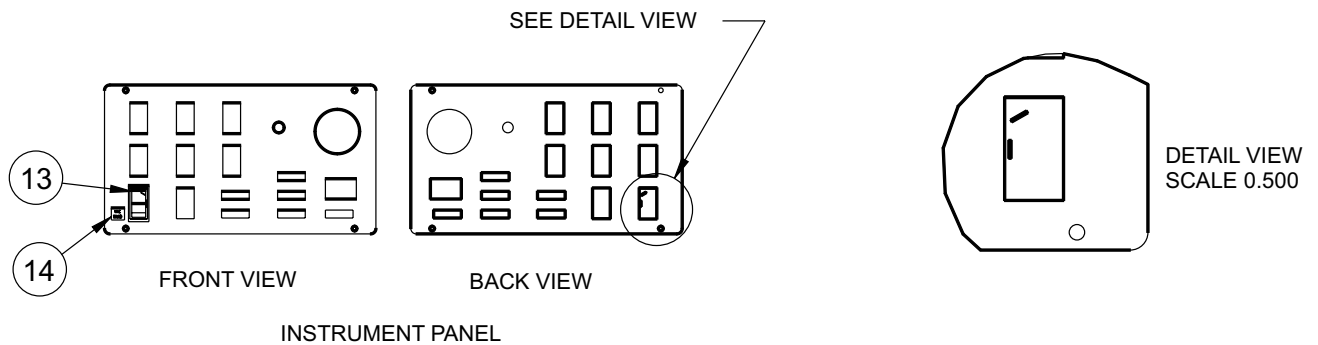

**SPRAY & VAC WAND (12V & 36V) (cont.)**

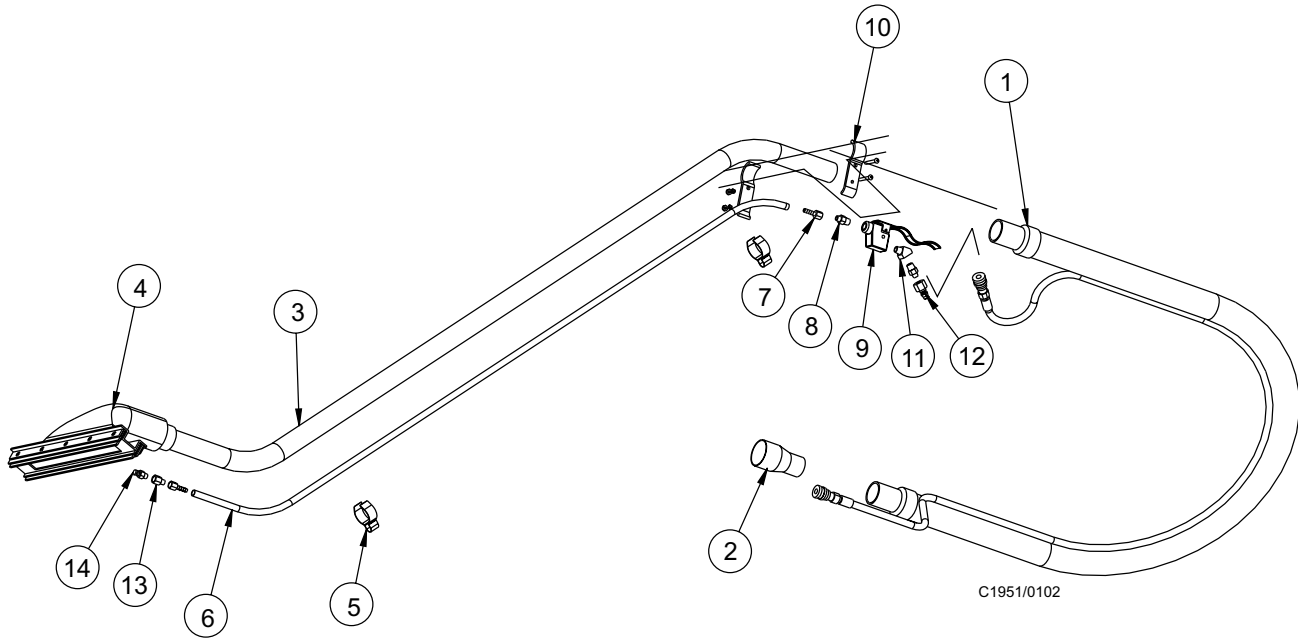

<u>Key No.</u>	<u>Part Number</u>	<u>Description</u>	<u>Qty.</u>
1	0261-029	Hose Assembly	1
2	7-03-00044	Adapter - Transition	1
3	0261-025	Wand Assembly	1
4	0261-024	Tool Assembly	1
5	7-13-07140	Clamp - Hose	2
6	7-33-02306	Hose - Solution Feed	1
7	2-00-05207	Adapter - 1/4 Hose x 1/8 NPT	2
8	2-00-05206	Reducer - Male Pipe 1/4 x 1/8	2
9	7-88-00058	Valve Solution 1/4 NPT	1
10	7-13-07139	Clamp - Valve	2
11	8-56-05026	45° Street Elbow	1
12	7-16-05028	Coupling - Quick Disconnect	1
13	2-00-05208	Adapter - 1/8 Pipe, Brass	1
14	7-50-01002	Spray Nozzle	1

C1651/0102

<u>Key No.</u>	<u>Part Number</u>	<u>Description</u>	<u>Qty.</u>
1	7-60-05036	Pump - Hyd.	1
2	0885-094	Hydraulic Motor	1
3	0885-078	Hydraulic Motor - Broom Drive	1
4	7-88-00080	Valve - Steering Control	1
5	7-88-00081	Valve - Solenoid (36V)	1
6	7-24-04013	Filter Assembly, Return	1
7	2-00-04957	Fitting - Cap 8ORS	1
8	2-00-04918	Fitting - Straight Connector	2
9	2-00-05442	Fitting - ORFS M to ORS M Boss 06 x 06	1
10	2-00-04977	Fitting - 9ORS - 6SAE, Str.	6
11	2-00-04974	Fitting - #8 ORS to # 10 SAE Connector	2
12	2-00-05441	Fitting - Long Str Male ORFS to ORS Boss 6x6	1
13	2-00-04895	Fitting - Straight Connector	2
14	2-00-05438	Fitting - 90 ORFS M to NPTF < 8 x 12	1
15	2-00-04892	Fitting - 90° Elbow (O-Ring)	4
16	2-00-05435	Fitting - 90 ORFS to ORS Boss 06 x 06	2
17	2-00-05437	Fitting - 90 ORFS to ORS Boss 08 x 06	1
18	2-00-04885	Fitting - 90° Elbow (O-Ring)	1
19	2-00-04924	Fitting - ¾-16 x 13/16-16 Tee	1
20	2-00-05440	Fitting - ORFA Female Swivel to ORS Boss M 06	1
21	2-00-05436	Fitting - ORFS M to NPTF M 08 x 12	1
22	7-33-02417	Hose - #8 Str-45, 13/16-16 Both Ends, 27.0 Lg	1
23	8-33-02179	Hose - #4 Str-Str, 9/16-18 Both Ends, 46.0 Lg	1
24	8-33-02184	Hose - #4 Str-Str, 9/16-18 Both Ends, 50.5	1
25	7-33-02428	Hose - #8 Str-90, 13/16-16 Both Ends, 57.0 Lg	1
26	2-00-04921	Fitting - IOSAE 90°-8ORS	3
27	8-33-02325	Hose - #8 Str-Str, 13/16-16 Both Ends, 65.0 Lg	1
28	7-33-02412	Hose - #8 Str-90, 13/16-16 Both Ends, 56.0 Lg	1
29	2-00-04928	Fitting - 13/16 - 16 x 13/16 - 16 Tee	1
30	7-33-02414	Hose - #8 Str-Str, 13/16-16 Both Ends, 82.0 Lg	1
31	7-33-02416	Hose - #6 Str-Str, 11/16-16 - 13/16-16, 58.0 Lg	1
32	2-00-04916	Plug - 9/16-16 O-Ring Boss	1
33	7-33-02431	Hose - #6 Str-Str, 13/16-16 Both Ends, 82.0 Lg	1
34	2-00-04973	Fitting - 12ORFS 12ORB, Str	1
35	2-00-04975	Fitting - 8SAE 45° Elbow	1
36	2-00-05439	Fitting - ORFS M To NPFT m 08 X 08	1
37	2-00-05453	Fitting - 12ORFS - ½NPT, Str.	1
38	2-00-05458	Fitting - Reducer 10 ORB M To 12 ORB F	1
39	2-00-05477	Fitting - Reducer, 8ORFS to 6ORFS	1
40	2-00-05481	Fitting - ORS To ORS Boss 06 x 06 Tee	1
41	7-33-02191	Hose - #4 Str -90, 9/16 - 18 Both Ends, 42 Lg	1
42	7-33-02222	Hose - #8 Str-Str, 13/16-16 Both Ends, 26.0 Lg	1
43	7-33-02225	Hose - #4 Str-90, 9/16 - 18 Both Ends, 38 LG	1
44	7-33-02402	Hose - #9 Str-90, 13/16-16 Both Ends, 22.0 Lg	1
45	7-33-02438	Hose - #8 Str-Str, 13/16-16 Both Ends, 51 Lg	1
46	7-33-02439	Hose - #6 90-45, 11/16-16 Both Ends, 20 Lg	1
47	7-33-02446	Hose-#12 Str-90, 1 3/16-12 Both End, 22.5±.25 Lg	1

**SCRUB BRUSH ASSY OPTION**

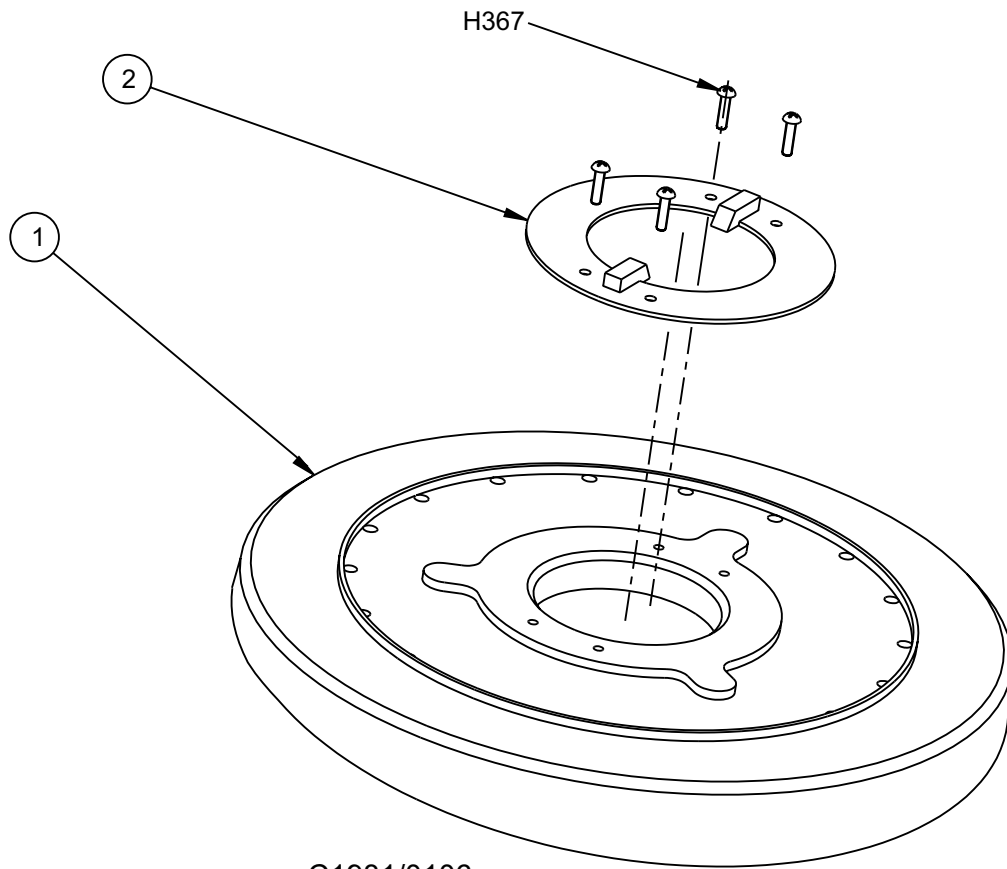

C1981/0106

<u>Key No.</u>	<u>Part Number</u>	<u>Description</u>	<u>Tuft Material</u>	<u>Item #</u>
1	0765-271	Black Nylon	.030 Black Nylon	7-08-03277
1	0765-272	Polypropylene	.040 Polypropylene	7-08-03278
1	0765-273	Supergrit	60/46/26 Brown	7-08-03279
1	0765-274	Clean Grit	35/180/30 Blue	7-08-03280
2	7-19-02035	Disc - Brush Driver		
HARDWARE USED				
	H367 2-00-00081	Screw, Ph. Rhm .25-20 x 1.000 Zn		4

C1981/0106

**Broom and Hopper Chamber Components**

<u>Part Number</u>	<u>Description</u>	<u>Qty</u>
7-25-08088	Flap - Main Broom Right	1
7-25-08089	Flap - Main Broom Left	1
7-25-08090	Flap - Main Broom Door	1
7-25-08091	Flap - Main Broom Rear	1
7-25-08092	Flap - Hopper	1
7-25-00256	Gasket - Broom Chamber Middle	1
7-25-00257	Gasket - Broom Chamber Right	1
7-25-00258	Gasket - Broom Chamber Left	1
7-25-00259	Gasket - Hopper	1

**Squeegee Components**

<u>Part Number</u>	<u>Description</u>	<u>Qty</u>
7-33-02420	Hose- Squeegee	1
7-77-00109	Squeegee - Rear Outer, 40" & 46"	1
7-77-00110	Squeegee - Rear Inner, 40" & 46"	1
7-77-00140	Rubber Side Squeegee, Inner 40"	1
7-77-00141	Rubber Side Squeegee, Outer 40"	1
7-24-04014	Hydraulic Filter	1
7-77-00142	Rubber Side Squeegee, Inner 46"	1
7-77-00143	Rubber Side Squeegee, Outer 46"	1

**Recovery Tank Components**

<u>Part Number</u>	<u>Description</u>	<u>Qty</u>
7-29-00250	Gasket - Recovery Tank Drain	1
7-29-00265	Gasket - Vac Recovery	1
7-68-05022	Sel - Tank Lid	1
7-29-00264	Gasket - Lid	1
7-33-02409	Cable - Solution Control	1

**Electrical Controls Components**

<u>Part Number</u>	<u>Description</u>	<u>Qty</u>
7-64-00037	Relay - 36V w/Diode Assembly	1
7-28-05015	Fuse - 25A	1

ACCELERATOR AND DIRECTIONAL CONTROL PEDAL .....	1-20
ACCESS PANELS .....	2-47
ADJUSTING CASTERS .....	1-35
ADJUSTING THE BRAKE PEDAL .....	1-32
ADJUSTING THE BRAKES .....	1-32
ADJUSTING THE DUST FLAPS .....	1-31
ADJUSTING THE FOOT THROTTLE SWITCH .....	1-32
ADJUSTING THE HOPPER SWITCH .....	1-30
ADJUSTING THE MAIN BROOM HEIGHT .....	1-28
ADJUSTING THE REAR SQUEEGEE LIFT .....	1-35
ADJUSTING THE SCRUB DECK LIFT .....	1-34
ADJUSTING THE SIDE BROOM HEIGHT .....	1-29
BACK-UP ALARM (12V & 36V) .....	3-2
BACK-UP ALARM SWITCH .....	1-20
BATTERY CONDITION LIGHT .....	1-16
BATTERY CONDITION METER .....	1-16
BATTERY POWERED MACHINE PREPARATION .....	1-11
BATTERY STAND .....	3-3
BRAKE ASSEMBLY .....	2-38
BRAKES .....	1-32
CONNECTION - HARNESS ROUTING (BATTERY) .....	1-46
COVERS AND LATCHES .....	1-34
DECALS .....	2-74
DECIMAL - METRIC CONVERSION TABLE .....	1-9
DUST CONTROL .....	2-50
DUST CONTROL FILTER .....	1-30
DUST CONTROL FILTER, CHECKING THE .....	1-30
DUST CONTROL SWITCH .....	1-17
DUST FLAPS .....	1-31
DUST FLAPS, CHECKING THE .....	1-31
ELECTRICAL POWER PANEL (36V) .....	2-68
ELECTRICAL SCHEMATIC (BATTERY) .....	1-45
EMPTYING THE RECOVERY TANK .....	1-36
ESP (12V & 36V) .....	3-4
ESP SYSTEM OPERATING INSTRUCTIONS .....	1-22
FILTER PANEL KNOB .....	1-20
FILTER SHAKER SWITCH .....	1-17
FIRE EXTINGUISHER .....	3-7
FOOT BRAKE .....	1-19
FORWARD AND REVERSE CONTROL (BATTERY) .....	2-36
FRONT COVER AND LATCH ASSEMBLY .....	2-44
FRONT WHEEL ASSEMBLY .....	2-40
GENERAL MACHINE MAINTENANCE .....	1-33
HARDWARE LEGEND .....	1-38
HELPFUL HINTS FOR CLEANING OPERATION .....	1-26
HOPPER .....	1-30
HOPPER ASSEMBLY (12V & 36V BATTERY) .....	2-10
HOPPER LIFT SWITCH .....	1-21
HOPPER, CLEANING THE .....	1-30
HORN BUTTON .....	1-15

## **INDEX**

---

HOOR METER .....	1-15
HYDRAULIC CONNECTION DIAGRAM .....	2-62
HYDRAULIC FILTER AND SOLENOID ASSEMBLY .....	2-60
HYDRAULIC MOTOR AND PUMP ASSEMBLY .....	2-56
HYDRAULIC KIT .....	3-21
HYDRAULIC RESERVOIR ASSEMBLY .....	2-59
HYDRAULIC RESERVOIR, FILLING THE .....	1-33
HYDRAULIC RESERVOIR LEVEL SIGHT GAUGE .....	1-19
HYDRAULIC SCHEMATIC (BATTERY) .....	1-47
HYDRAULIC SYSTEM, CLEANING THE .....	1-33
HYDRAULIC TORQUE REQUIREMENTS .....	1-8
INSTRUMENT PANEL .....	2-70
INSTRUMENT PANEL (12V) .....	2-62
KEY SWITCH .....	1-15
LIGHT PACKAGE .....	3-8
LIGHT SWITCH .....	1-15
LOW SOLUTION LIGHT (WARNING LIGHT) .....	1-19
MACHINE DIMENSIONS .....	1-6
MACHINE PREPARATION .....	1-10
MAIN BROOM .....	1-28
MAIN BROOM ASSEMBLY .....	2-2
MAIN BROOM ADJUSTMENT .....	1-17
MAIN BROOM AND SIDE BROOM SWITCH .....	1-17
MAIN BROOM BAFFLE AND FLAPS .....	2-6
MAIN BROOM COMPARTMENT DOOR .....	1-21
MAIN BROOM LEVEL ADJUSTMENT .....	1-28
MAIN BROOM SWEEP PATTERN, CHECKING THE .....	1-28
MOTOR AND PUMP MOUNTING ASSEMBLY .....	2-58
OPERATING INSTRUCTIONS .....	1-23
OPERATION OF CONTROLS AND GAUGES .....	1-15
ORDERING PARTS .....	1-44
OVER HEAD GUARD (OHG) .....	3-9
PAD DRIVER (20") .....	3-16
PARKING BRAKE .....	1-19
PARTS LIST LEGEND .....	1-37
POST-OPERATION CHECKLIST .....	1-23
POWER PANEL(36V) .....	2-64
POWER STEERING .....	2-66
PREPARING THE MACHINE FOR OPERATION .....	1-10
PRE-START CHECKLIST .....	1-23
REAR SQUEEGEE .....	1-35
REAR SQUEEGEE (40") .....	2-22
REAR SQUEEGEE (46") .....	2-24
REAR SQUEEGEE LIFT SYSTEM (12V AND 36V) .....	2-26
REAR WHEEL ASSEMBLY .....	2-42
RECOVERY HIGH LIGHT (WARNING LIGHT) .....	1-19
RECOVERY HIGH WARNING LIGHT .....	1-34
RECOVERY OR ESP SYSTEM - HOW IT WORKS .....	1-22
RECOVERY TANK .....	2-34
<b>RECYCLING PUMP ESP SYSTEM</b> .....	<b>1-35</b>
AMERICAN-LINCOLN TECHNOLOGY .....	3-25
SMART 2000 .....	

RECYCLING PUMP STORAGE .....	1-35
REPLACING THE DUST CONTROL FILTER .....	1-31
REPLACING THE MAIN BROOM .....	1-28
REPLACING THE RETURN FILTER ELEMENT .....	1-33
REPLACING THE SCRUB BRUSH .....	1-34
REPLACING THE SIDE BROOM .....	1-29
ROLLOUT BATTERY .....	2-48
SAFETY INSTRUCTIONS .....	1-12
SCRUB BRUSH ASSY OPTIONAL BRUSHES .....	3-22
SCRUB DECK ACTUATOR .....	2-12
SCRUB DECK ASSEMBLY (40") .....	2-14
SCRUB DECK ASSEMBLY (46") .....	2-17
SCRUB DECK SWITCH .....	1-18
SEAT ASSEMBLY .....	2-46
SEAT BELT ASSEMBLY .....	3-14
SEAT POSITION ADJUSTMENT .....	1-16
SERVICE CHART .....	1-24
SERVICE INSTRUCTIONS .....	1-28
SERVICE PRECAUTIONS .....	1-27
SIDE BROOM .....	1-29
SIDE BROOM (12V & 36V) .....	2-8
SIDE BROOM ADJUSTMENT .....	1-17
SIDE SQUEEGEE (40") .....	2-19
SIDE SQUEEGEE (46") .....	2-20
SOLUTION CONTROL .....	1-34
SOLUTION CONTROL ASSEMBLY .....	2-32
SOLUTION CONTROL KNOB .....	1-18
SOLUTION LOW WARNING LIGHT .....	1-34
SOLUTION TANK .....	2-30
SPARE PARTS KIT .....	3-23
SPECIFICATIONS .....	1-4
SPRAY & VAC WAND (12V & 36V) .....	3-17
SQUEEGEE CASTER WHEELS .....	1-35
SQUEEGEE SWITCH .....	1-18
SQUEEGEE WAND .....	3-15
STANDARD HARDWARE & TORQUE VALUES .....	1-7
STARTING BATTERY MACHINES .....	1-23
STARTING THE ENGINE, BEFORE .....	1-23
STROBE LIGHT WITH OHG (12 & 36 VDC) .....	3-12
STROBE LIGHT WITHOUT OHG (12 & 36 VDC) .....	3-10
SWING SQUEEGEE SUPPORT .....	2-28
THE NON-RECYCLING OR STANDARD SCRUBBING SYSTEM - HOW IT WORKS .....	1-22
THE SCRUBBING SYSTEM - HOW IT WORKS .....	1-22
TURN SIGNAL (4-WAY) OPTION .....	1-19
VACUUM MANIFOLD SYSTEM .....	2-54
WARRANTY .....	3-25

**AMERICAN-LINCOLN TECHNOLOGY  
RIDER SWEEPER / SCRUBBER  
"BUMPER-TO-BUMPER" LIMITED WARRANTY**

**I. COVERAGE**

A. Subject to the terms and limitations stated herein, American-Lincoln warrants, to the original purchaser only, to repair or replace, at its option and upon the terms set out below, this product or any parts thereof (excluding normal maintenance items) which are defective in materials or workmanship, for a period of (2) two years or 2,000 hours of normal operation from the date of purchase, whichever comes first, provided that the product is operated and maintained in accordance with American-Lincoln's Maintenance and Operations Instruction.

1. (a) During the first (90) ninety days from the date of purchase, American-Lincoln will provide, without charge, parts and on-site labor (including up to three (3) hours total round-trip travel time) to remedy a defective product or part.

(b) During the next (9) nine months or 1,000 hours (whichever come first) American-Lincoln will provide, without charge, parts and labor to remedy a defective product or part; however all travel time for on-site remedy and all shipping and freight charges for off-site remedy of the product or parts thereof shall be the sole responsibility of the purchaser.

(c) During the next (12) twelve months or a total of 2000 hours (whichever comes first) American Lincoln will provide, without charge, parts to remedy a defective product or part, however all labor, travel time for on-site remedy and all shipping and freight charges for off-site remedy of the product or parts thereof shall be the sole responsibility of the purchaser.

B. In addition to the terms listed above, if applicable, the following additional warranty coverage is applied.

1. (a) American-Lincoln warrants to the original purchaser only, to repair or replace, at its option and upon the terms set out below, the drive line electrical components including the electric drive propulsion motor, electric wheel drive motor and electronic drive controller, and all hydraulic pumps and motors, to provide replacement parts which are defective in material or workmanship, for a period of (3) years or 3000 hours (whichever comes first) provided that the product is operated and maintained in accordance with American-Lincoln's Maintenance and Operations Instruction.

(b) American Lincoln warrants to the original purchaser only, to repair or replace, at its option and upon the terms set out below, the internal combustion liquid cooled engine, to provide replacement parts which are defective in material or workmanship, for a period of (5) five years or unlimited hours of normal operation. All labor, travel time, shipping and freight charges shall be the sole responsibility of the purchaser.

(c) American-Lincoln, warrants to the original purchaser only, to repair or replace, at its option and upon the terms set out below, the main frame, debris hopper, solution tank, and the recovery tank, for the life of the machine against failure caused by defects in workmanship or total rust through. For purposes of this coverage, cosmetic deterioration or surface rust does not constitute a failure.

(d) American-Lincoln, warrants to the original purchaser only, to repair or replace, at its option and upon the terms set out below, the batteries which becomes unserviceable under normal use within a period of ninety (90) days from date of sale to the original user with new batteries of equal value. After expiration of the above ninety (90) day period, any battery which fails under normal use will be adjusted to the original user with a new battery of equal specifications on an eighteen (18) months pro rate basis from the date of purchase. Adjustment will be determined using the then current list price, plus transportation costs. Warranty is rendered NULL and Void if battery is not kept filled to the proper level with DISTILLED WATER.

**II. EXCLUSIONS**

This warranty **does not** cover normal maintenance parts and labor, including but not limited to, rubber parts, seals, flaps, brushes, engine maintenance parts, hoses, carbon motor brushes, fluids and routine adjustments.

This warranty **does not** cover damage or failure of the product or any parts thereof which is the result of misuse, negligent operation, handling or repair, or which is the result of modification by any person other than an authorized American-Lincoln service representative.

**III. LIMITATIONS**

A. AMERICAN-LINCOLN MAKES NO WARRANTIES OTHER THAN THOSE SPECIFIED HEREIN. ALL IMPLIED WARRANTIES OF MERCHANTABILITY AND OF FITNESS FOR A PARTICULAR PURPOSE ARE EXPRESSLY EXCLUDED. AMERICAN-LINCOLN LIABILITY UNDER THIS WARRANTY IS LIMITED TO REPAIR AND/OR REPLACEMENT OF PRODUCTS OR PARTS AS SET OUT HEREIN. AMERICAN-LINCOLN SHALL NOT BE LIABLE FOR ANY INCIDENTAL OR CONSEQUENTIAL DAMAGES WHICH MAY RESULT FROM A PRODUCT OR PART DEFECT OR FAILURE. ANY EXTENSIONS OF OR MODIFICATIONS MADE TO THIS WARRANTY BY A DISTRIBUTOR OF AMERICAN-LINCOLN ARE THE SOLE RESPONSIBILITY OF THE DISTRIBUTOR.

IV. PROCEDURES AND CONDITIONS FOR WARRANTY CLAIMS AMERICAN-LINCOLN SHALL NOT BE LIABLE FOR REPAIR OR REPLACEMENT OF ANY DEFECTIVE PRODUCT OR PART THEREOF UNLESS AND UNTIL THE ORIGINAL PURCHASER FULFILLS THE FOLLOWING CONDITIONS PRECEDENT TO RECOVERY UNDER THIS WARRANTY:

The original purchaser shall promptly complete and return the warranty and installation registration form included with the product at the time of the purchase;

Upon product or part failure, the original purchaser shall promptly provide notice thereof to his nearest authorized American-Lincoln Service Representative; and

The original purchaser shall permit the product or part to be inspected by American-Lincoln or its authorized representatives, as necessary and expenses for shipping or travel time shall be borne by the parties itemized in paragraph I herein above.

American-Lincoln Technology reserves the right to make changes and improvements to its machines without notice. For best results, use only the correct American-Lincoln Service parts.

AMERICAN-LINCOLN TECHNOLOGY  
1100 HASKINS ROAD  
BOWLING GREEN, OHIO 43402