



Electronic Service Manuals

This electronic document is provided as a service to our customers. We do not create the contents of the information contained in this document. Should you have detailed questions pertaining to the information contained in this document, you may contact Michco, or the manufacturer which provided the original information in this electronic deliverable. Michco's only part in this electronic deliverable was the electronic assembly process.

You may contact Michco through the following methods:
Phone (517) 484-9312 or (800) 331-3339 MI, OH, IN only
2011 N. High St. -- Lansing, Michigan -- 48906
Fax: (517) 484-9836
Email: CustServ@Michco.com
Web site: www.Michco.Com
Parts Web site: www.FloorMachineParts.Com

Order Parts on Line at:
www.FloorMachineParts.Com

Directly to Parts & Service:
By Email: **Shop@Michco.com**
By Fax: (517) 702-2041
By Voice: Use numbers above.

Serving the Cleaning Industry Since 1922

Notice: All copyrighted material remains property of original owners, all trademarks are property of respective owners. Manuals are subject to Manufacturer's reproduction limitations. Originals or reproductions were provided by manufacturers through a request. We make no warranty as to the correctness of information provided in this document and you assume all risk.

AdVac™ 12XP

PARTS LIST

**Advance MODELS 56703789(Obsolete)
56703660(Obsolete), 56703661(Obsolete)**



Advance
by Nilfisk-Advance

revised 11/02 Form Number 56042260

TABLE OF CONTENTS

<u>DESCRIPTION</u>	<u>PAGE</u>
Bag Housing	1-2
Brush Housing	3-4

WHEN ORDERING PARTS

- * Use the 8 digit numbers from the "Ref. No." columns in this parts list.
- * Specify the model and serial number of the machine.
- * Use the space below to record the model and serial number for future reference.

Model _____ Serial No. _____

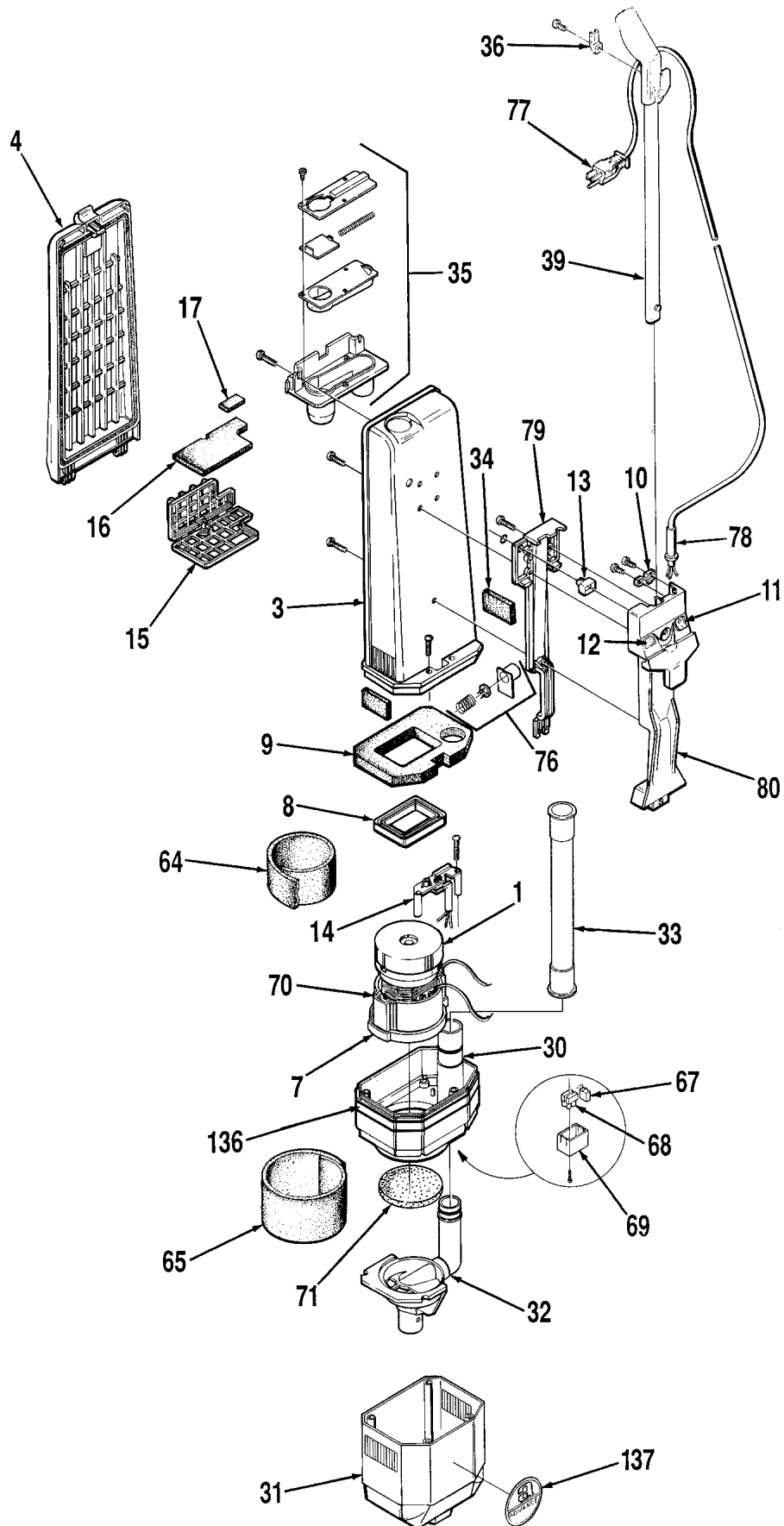

BAG HOUSING

Item	Ref. No.	Qty	Description				
	56703830	1	Bag Housing Assembly 120V				
	56703842	1	Bag Housing Assembly 220V				
	56703846	1	Bag Housing Assembly 240V				
1	56704237	1	Vac Motor 120V TSB 596				
*	56704238	2	Carbon Brush for 56704237 & 56704237 TSBUS2002-829				
	56703640	1	Vac Motor 220V TSB 596				
	56703641	1	Vac Motor 240V TSB 596	*	56703658	1	Cloth Bag
3	56703797	1	Bag Housing	*	56703677	1	Bag Clip for Cloth Bag
4	56703703	1	Bag Housing Cover	*	56703811	1	Paper Bags (pkg of 10)
7	56703704	1	Vacuum Motor Support Gasket				
8	56703705	1	Gasket	*	56703790	1	Tool Kit, Includes:
9	56703798	1	Filter	*	56703771	2	Extension Tube
10	56703977	1	Cord Clamp	*	56703772	1	Tube Bend with Suction Control
11	56703708	1	Main Switch	*	56703774	1	Upholstery Tool
12	56703709	1	Indicator Light	*	56703785	1	Round Dusting Brush
13	56703099	1	Electric System Kit	*	56704216	1	Hose Assembly (Semi-Flex with sleeves)
14	56703711	1	Cord Clamp	*	56703725	1	Crevice Tool
15	56703712	1	Filter Holder				
16	56703713	1	Filter				
17	56703714	1	Scented Pad (pkg of 5)				
30	56703801	1	Inner Vacuum Motor Housing				
31	56703802	1	Outer Vacuum Motor Housing				
32	56703803	1	Vacuum Motor Support TSB 576				
33	56703792	1	Internal Tube				
34	56703796	1	Relief Valve Filter				
35	56703791	1	Bag Adapter				
36	56703793	1	Strain Relief				
39	56703794	1	Handle Tube Assembly				
	56703827	1	Handle Grip (only)				
	56703828	1	Tube (only)				
64	56703775	1	Foam				
65	56703776	1	Foam				
67	56703784	1	RFI Filter				
68	56703783	1	Terminal Block				
69	56703782	1	Cover				
70	56703781	1	Vacuum Motor Shell				
71	56703780	1	Filter				
76	56703779	1	Relief Valve				
77	56703795	1	Cord 120 Volt				
	56703974	1	Cord 220 Volt				
	56703982	1	Cord 240 Volt				
79	56703729	1	Frame Handle Switch Assembly				
*	56703839	2	Handle Wire Assembly required for 56703729				
80	56703730	1	Handle Cover				
136	56015026	1	Decal, Stripe				
137	56017019	1	Decal, Advance				

* = Optional Accessory, not shown.

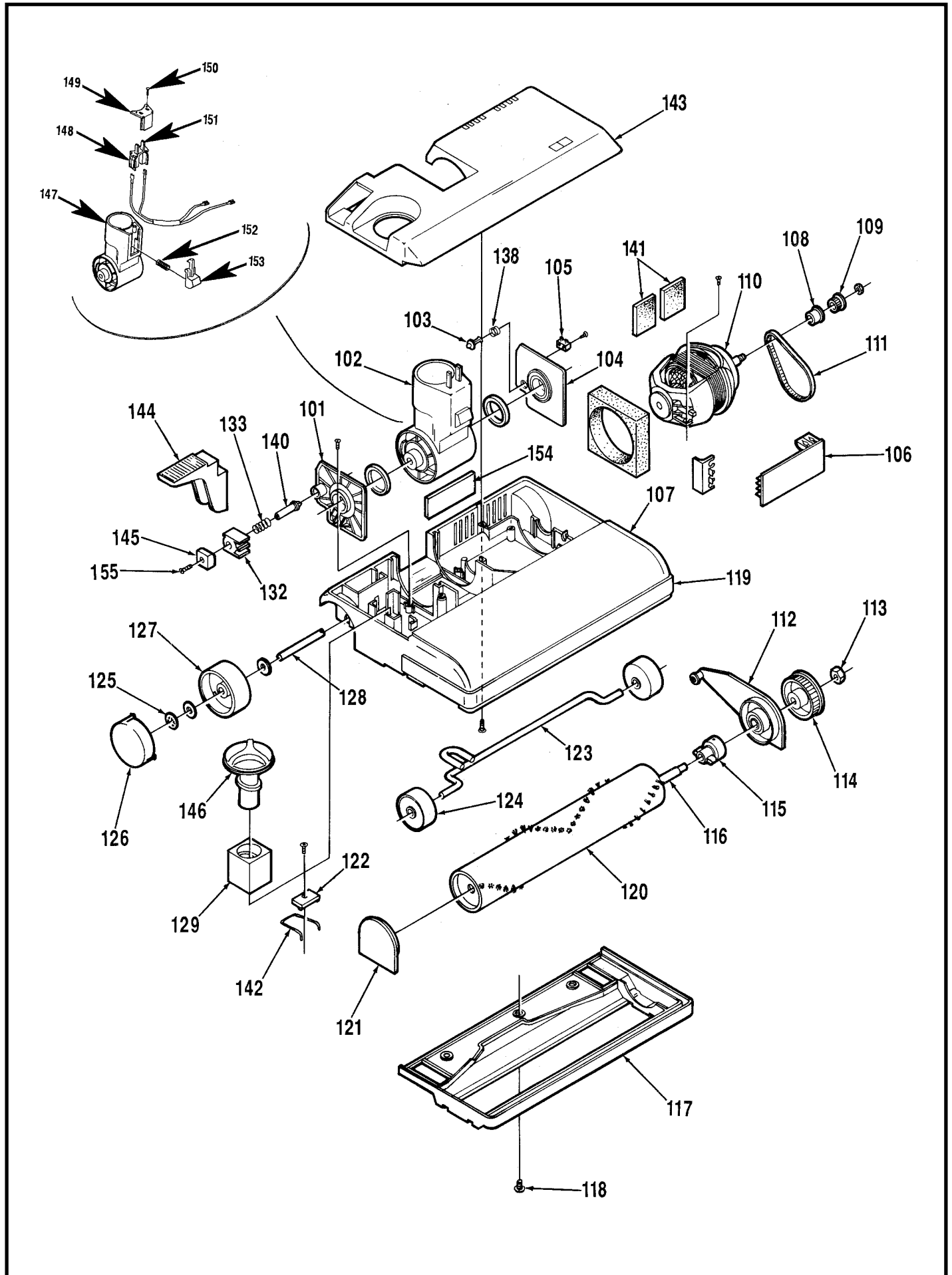

BRUSH HOUSING

Item	Part No.	Qty	Description	Item	Ref. No.	Qty	Description
	56703840	1	Brush Housing Assy 120V	124	56703757	2	Front Wheel
	56703844	1	Brush Housing Assy 220V	125	56703758	2	Wheel Retainer Note 1
	56703848	1	Brush Housing Assy 240V	126	56703759	2	Wheel Cover Note 1
101	56703734	1	Right Connector Support	127	56703760	2	Rear Wheel Note 1
102	56703735	1	Connector Assembly TSB 676	128	56703761	2	Rear Axle
103	56704023	1	Switch Activator Pin	129	56703762	1	Brush Adjuster
104	56703737	1	Left Connector Support	132	56703765	1	Bushing
105	56703738	1	Brush Motor Switch	133	56703766	1	Spring
106	56703804	1	Circuit Board 120 Volt	138	56703659	1	Spring
	56703646	1	Circuit Board 220 Volt	140	56703778	1	Plunger Note 2
	56703647	1	Circuit Board 240 Volt	141	56703728	1	Filter (set of 2)
107	56703807	1	Base Housing	142	56703777	1	Spring
*	56703856	4	Brass Nut Sert	143	56703733	1	Base Housing Cover
108	56703741	1	Pulley Spacer	144	56703767	1	Handle Release Pedal
109	56703742	1	Brush Motor Pulley	145	56703763	1	Slide
*		1	M4 Metric Pulley Nut	146	56703764	1	Brush Adjuster Knob
110	56703743	1	Brush Motor 120 Volt	148	56703667	1	Prong Support
	56703644	1	Brush Motor 220 Volt	149	56703669	1	Retainer
	56703657	1	Brush Motor 240 Volt	150	56703668	2	Screw
111	56703744	1	Belt	151	56703666	2	Prong
112	56703745	1	Left Brush Support W/Bearing	152	56703786	1	Spring
113	56703746	1	Brush Pulley Nut	153	56703670	1	Button
114	56703747	1	Brush Pulley	154	56703788	1	Felt Seal (set of 2)
115		1	Brush Insert	155	56704065	2	Screw, 2.9 x 16
116	56703809	1	Brush Shaft with insert				
117	56703810	1	Brush Shoe Plate				* = Not Shown
118	56703751	4	Screw				
119	56703806	1	Bumper				
120	56703808	1	Brush				
121	56703754	1	Right Brush Support W/Bearing				
122	56703755	1	Spring Stop Plate				
123	56703756	1	Front Axle				

Note 1: Old rear wheel arrangement consisting of three parts (56703758, 56703759 and 56703760) has been replaced with a newer wheel arrangement consisting of two parts (56704033 and 703760). Individual parts are not interchangeable, but the wheel arrangements are interchangeable. Both wheel arrangements are still available. Two wheels per machine.

Note 2: When 56703778 is ordered, the plunger kit 56100675 is sent.



Nilfisk-Advance, Inc.
14600 21st Avenue North
Plymouth, MN, 55447-3408
www.nilfisk-advance.com
Phone: 800-989-2235
Fax: 800-989-6566
©2002 Nilfisk-Advance, Inc.,
Plymouth, MN 55447-3408
Printed in the U.S.A.