



Electronic Service Manuals

This electronic document is provided as a service to our customers. We do not create the contents of the information contained in this document. Should you have detailed questions pertaining to the information contained in this document, you may contact Michco, or the manufacturer which provided the original information in this electronic deliverable. Michco's only part in this electronic deliverable was the electronic assembly process. By providing this manual on line we are not guaranteeing parts availability.

You may contact Michco through the following methods:

Phone (517) 484-9312 or (800) 331-3339

2011 N. High St. -- Lansing, Michigan -- 48906

Fax: (517) 484-9836

Email: CustServe@Michco.com

Web site: www.Michco.Com

Parts Web site: www.FloorMachineParts.Com

Order Parts on Line at:

www.FloorMachineParts.Com

Directly to Parts & Service:

By Email: **Shop@Michco.com**

By Fax: (517) 702-2041

By Voice: Use numbers above.

Serving the Cleaning Industry Since 1922

Notice: All copyrighted material remains property of original owners, all trademarks are property of respective owners. Manuals are subject to Manufacturer's reproduction limitations. Originals or reproductions were provided by manufacturers through a request. We make no warranty as to the correctness of information provided in this document and you assume all risk. By placing these manuals on line we are not declaring our corporation to be an manufacturer authorized dealer or provider, please check our web site for authorized manufacturers we represent.

SW900



Service Manual

Advance SW900 Battery – 9084112010

Nilfisk SW900 Battery - 9084110010

Nilfisk SW900 Petrol - 9084111010



English

2013-11 Form No. 1465376000

Contents

General Information	5
Machine General Description	5
Service Manual Purpose and Field of Application	5
Other Reference Manuals	5
Conventions	6
Service and Spare Parts	6
Serial Number Label	6
Safety	7
Visible Symbols on the Machine	7
Symbols	7
General Instructions	7
Machine Lifting	11
Machine Transportation	11
Machine Nomenclature (SW900 B) (know your machine)	12
Machine Nomenclature (SW900 P) (know your machine)	16
Service and Diagnostic Equipment	20
Technical Data	21
Machine Material Composition and Recyclability	22
Dimensions	23
Maintenance	24
Scheduled Maintenance Table (SW900 B)	24
Scheduled Maintenance Table (SW900 P)	25
Frame System	26
Frame (main parts)	26
Dust Control System	27
Functional Description	27
Wiring Diagram (SW900 B)	27
Wiring Diagram (SW900 P)	28
Component Locations	29
Maintenance and Adjustments	30
Panel dust filter, cleaning and integrity check/replacement	30
Troubleshooting	32
Removal and Installation	33
Electrical filter shaker motor amperage check	33
Electrical Filter Shaker Motor Disassembly/Assembly	35
Specifications	37
Electrical and Control System	38
Functional Description (SW900 B)	38
Electrical Protections	38
Functional Description (SW900 P)	39
Electrical Protections	39
Wiring Diagram	40
Fuses	40
Relays / Electromagnetic Switches / Diodes	40
Wiring Diagram (SW900 B)	41
Wiring Diagram (SW900 P)	42
Component Locations (SW900 B)	43
Component Locations (SW900 P)	46
Maintenance and Adjustments	49
Charging the batteries (SW900 B)	49

Fuse Check/Replacement/Reset (SW900 B)	51
Fuse Check/Replacement/Reset (SW900 P)	53
Troubleshooting (SW900 B)	54
Removal and Installation	55
Battery Installation and Battery Type Setting (WET or GEL) (SW900 B)	55
Machine Check/Setting	57
Main motor amperage check (SW900 B)	59
Dynamotor Voltage Check (SW900 P)	61
Main motor carbon brush replacement (SW900 B)	63
Dynamotor Carbon Brush Replacement (SW900 P)	64
Main Motor or Fan Removal/Installation (SW900 B)	65
Dynamotor Removal/Installation (SW900 P)	69
Reduction Unit Removal/Installation	73
Main Broom Shaft (Small) Gear Removal/Installation	74
Drive Shaft (Big) Gear Removal/Installation	77
Battery Charger Removal/Installation (SW900 B)	80
Hopper Position Switch Operation Check, Removal/Installation	82
Specifications	84
Petrol Engine System	85
Functional Description	85
Wiring Diagram	85
Component Locations	86
Maintenance and Adjustments	87
Engine RPM Check and Adjustment	87
Troubleshooting	89
Removal and Installation	90
Engine Belt Check/Adjustment/Replacement	90
Petrol Engine Assembly Removal/Installation	93
Specifications	97
Hopper System	98
Functional Description	98
Component Locations	99
Specifications	100
Main Broom System	101
Functional Description	101
Wiring Diagram	101
Component Locations	102
Maintenance and Adjustments	103
Main Broom Height Check and Adjustment	103
Skirt Height Check and Adjustment	104
Troubleshooting	107
Removal and Installation	108
Main Broom Removal/Installation	108
Main Broom Belt Check/Replacement	111
Main Broom Pulley and Hexagonal Drive Hub Replacement	113
Skirt Removal/Installation	114
Specifications	117
Side Broom System	118
Functional Description	118
Battery Version	118
Petrol Version	118
Wiring Diagram (SW900 B)	119
Wiring Diagram (SW900 P)	119
Component Locations	120

Maintenance and Adjustments	121
Side Broom Height Check and Adjustment.	121
Troubleshooting	122
Removal and Installation	123
Side Broom Disassembly/Assembly	123
Side Broom Motor Amperage Check	124
Side Broom Reduction Unit Removal/Installation	125
Right Side Broom Control Cable Removal/Installation	126
Side Broom Microswitch Adjustment and Removal/Installation	128
Specifications	130
Wheel System, Traction	131
Functional Description.	131
Component Locations	132
Maintenance and Adjustments	133
Troubleshooting	134
Removal and Installation	135
Drive system control cable, disassembly/assembly.	135
Drive belt, check/replacement.	136
Specifications	137

General Information

Machine General Description

The SW900 is a “man-down” industrial machine designed to clean/sweep floors, in civil or industrial environments, in one pass. The machine can be supplied in one of the following version:

- with a rechargeable battery, installed on the machine (SW900 B)
- with a dynamotor driven by a petrol engine, both installed on the machine (SW900 Petrol)

The machine is equipped with one main cylindrical broom, and one or two side disc brooms.

The front hopper and a vacuum system allow for dust and dirt collection.

Service Manual Purpose and Field of Application

The Service Manual is a technical resource intended to help service technicians when carrying out maintenance and repairs on the SW900, to guarantee the best cleaning performance and a long working life for the machine.

Please read this manual carefully before performing any maintenance and repair procedure on the machine.

Other Reference Manuals

Model	Product Code	User Manual	Spare Parts List
SW900 B - Advance	9084112010	1465374000	1465375000
SW900 B - Nilfisk	9084110010	1465366000	1465367000
SW900 P - Nilfisk	9084111010	1465371000	1465372000

Assembly Instructions	Instruction Code	Machines concerned
LEFT SIDE BROOM KIT	1465407000	9084112010 – 9084110010 - 9084111010
MANUAL FILTER SHAKER KIT	1465626000	9084110010 - 9084111010
ELECTRICAL FILTER SHAKER KIT	1465627000	ONLY FOR N-ALTO VERSIONS (NOT FOR THIS VERSION)

These manuals are available at:

- Local Nilfisk-Advance Retailer
- Nilfisk-Advance website: www.Nilfisk-Advance.com

Conventions

Forward, backward, front, rear, left or right are intended with reference to the operator’s position when driving.

Service and Spare Parts

Service and repairs must be performed only by authorised personnel or Nilfisk Service Centers. The authorised personnel is trained directly at the manufacturer’s premises and has original spare parts and accessories. Contact Nilfisk Retailer indicated below for service or to order spare parts and accessories, specifying the machine model and serial number.

(Apply Retailer label here)

Serial Number Label

The machine serial number and model name are marked on the plate (see the example to the side). Product number and year of production are marked on the same plate. This information is useful when requiring machine spare parts. Use the following table to write down the machine identification data.

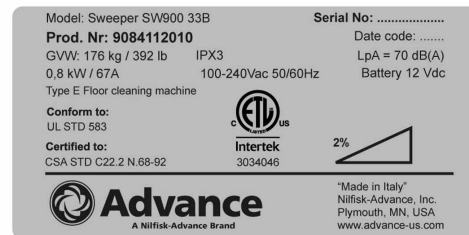

P200249







MACHINE model
PRODUCT code
MACHINE serial number

ENGINE model
ENGINE serial number

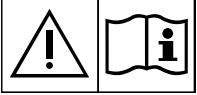
Safety

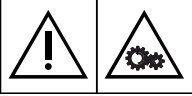
The following symbols indicate potentially dangerous situations. Always read this information carefully and take all necessary precautions to safeguard people and property.

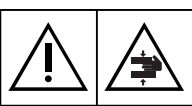
Visible Symbols on the Machine

	WARNING! Carefully read all the instructions before performing any operation on the machine.		WARNING! Hot parts, danger of burns.
	DANGER! Internal combustion engine. Do not inhale exhaust gas fumes. Carbon monoxide (CO) can cause brain damage or death.		WARNING! Moving parts.
	WARNING! Do not wash the machine with direct or pressurized water jets.		WARNING! Moving parts. Danger of crushing.
	WARNING! Do not use the machine on slopes with a gradient exceeding the specifications.		WARNING! Parts under voltage. Presence of corrosive fluids.

Symbols



Danger! It indicates a dangerous situation with risk of death for the operator.



Warning! It indicates a potential risk of injury for people or damage to objects.



Caution! It indicates a caution related to important or useful functions.



Note: It indicates a remark related to important or useful functions.

General Instructions

Specific warnings and cautions to inform about potential damages to people and machine are shown below.



Warning! Make sure to follow the safety precautions to avoid situations that may lead to serious injuries.

(For SW900 B/Petrol)

- Before performing any maintenance, repair, cleaning or replacement procedure disconnect the battery connector, remove the ignition key and engage the parking brake; for SW900 B also disconnect the batteries. Make sure that the machine cannot move independently.
- This machine must be used by properly trained operators only.
- Keep the batteries away from sparks, flames and incandescent material. Explosive gases are released when charging the batteries.

- Do not wear jewels when working near electrical components.
- Do not work under the lifted machine without supporting it with safety stands.
- When working under the open hood, ensure that it cannot be closed by accident.
- Do not operate the machine near toxic, dangerous, flammable and/or explosive powders, liquids or vapors: This machine is not suitable for collecting dangerous powders.

(For SW900 P)

- Carbon monoxide (CO) can cause brain damage or death.
- The internal combustion engine of this machine can emit carbon monoxide.
- Do not inhale exhaust gas fumes.
- Only use indoors when adequate ventilation is provided, and with the help of an assistant.
- Be careful: fuel is highly flammable.
- Do not smoke or bring naked flames in the area where the machine is refuelled or where the fuel is stored.
- Refuel outdoors or in a well-ventilated area, with the engine off.
- Turn off the engine and let it cool down for a few minutes, then remove the fuel tank plug.
- To allow the fuel to expand, do not fill the fuel tank beyond the upper limit mark (A) shown in the figure.

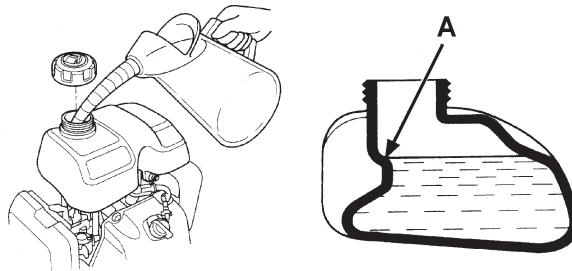

P200250

- After refuelling, check that the fuel tank cap is firmly closed.
- If any fuel is spilled while refuelling, clean the tank area and allow the vapors to evaporate before starting the engine.
- Do not let fuel come into contact with the skin; do not breathe fuel vapors. Keep out of reach of children.
- Do not tilt the engine or the machine too much to avoid fuel spillage.
- Do not lay any object on the engine.
- Stop the engine before performing any procedure on it. To avoid any accidental start, disconnect the spark plug cap.
- See also the SAFETY RULES in the Engine Manual, which is to be considered an integral part of this Manual.

(For SW900 B)

- If the machine is equipped with lead (WET) batteries, battery charging produces highly explosive hydrogen gas. Charge the batteries in well-ventilated areas and away from naked flames.
- When lead batteries (WET) are installed, do not tilt the machine for more than 30° from the horizontal plane to prevent the highly corrosive acid from leaking out of the batteries. When the machine is to be tilted to perform maintenance procedures, remove the batteries.



Warning! *Make sure to follow the safety precautions to avoid situations that may lead to serious injuries, damages to materials or equipments.*

(For SW900 B/Petrol)

- Carefully read all the instructions before performing any maintenance/repair procedure.
- This machine is not intended for use by persons (including children) with reduced physical, sensory or mental capabilities, or lack of experience and knowledge, unless they have been given supervision or instruction concerning use of the machine by a person responsible for their safety. Children should be supervised to ensure that they do not play with the machine.
- Close attention is necessary when used near children.
- Use only as shown in this Manual. Only Nilfisk-Advance recommended accessories must be used.
- Check the machine carefully before each use, always check that all the components have been assembled before use. If the machine is not perfectly assembled it can cause damages to people and properties.
- Take all necessary precautions to prevent hair, jewels and loose clothes from being caught by the machine moving parts.
- To avoid any unauthorized use of the machine, remove the ignition key.
- Do not leave the machine unattended without being sure that it cannot move independently.
- Do not use the machine on incline.
- Do not tilt the machine more than the angle indicated on the machine itself, in order to prevent instability.
- Use only brooms supplied with the machine or those specified in the User Manual. Using other brooms could reduce safety.
- Before using the machine, close all doors and/or covers as shown in the User Manual.
- Do not wash the machine with direct or pressurised water jets, or with corrosive substances.
- Use the machine only where a proper lighting is provided.
- While using this machine, take care not to cause damage to people or objects.
- Do not bump into shelves or scaffoldings, especially where there is a risk of falling objects.
- Do not lean liquid containers on the machine, use the relevant can holder.
- The storage temperature must be between 0°C and +40°C.
- The machine working temperature must be between 0°C and +40°C.
- The humidity must be between 30% and 95%.
- Always protect the machine against the rain and bad weather, both under operation and inactivity condition. Store the machine indoors, in a dry place. This machine must be used in dry conditions, it must not be used or kept outdoors in wet conditions.
- Do not use the machine as a means of transport, or for pushing/towing.
- Do not allow the brooms to operate while the machine is stationary to avoid damaging the floor.
- The machine maximum capacity is 30 kg (the maximum weight of waste).
- In case of fire, use a powder fire extinguisher, not a water one.
- This machine cannot be used on roads or public streets.
- Do not tamper with the machine safety guards.
- Follow the routine maintenance procedures scrupulously.
- Do not allow any object to enter into the openings. Do not use the machine if the openings are clogged. Always keep the openings free from dust, hairs and any other foreign material which could reduce the air flow.
- Do not remove or modify the plates affixed to the machine.
- In case of machine malfunctions, ensure that these are not due to lack of maintenance. If necessary, request assistance from the authorised personnel or from an authorised Service Center.
- If parts must be replaced, require ORIGINAL spare parts from an Authorised Dealer or Retailer.
- To ensure machine proper and safe operation, the scheduled maintenance shown in the relevant chapter of this Manual, must be performed by the authorised personnel or by an authorised Service Center.
- The machine must be disposed of properly, because of the presence of toxic-harmful materials (batteries, oils, etc.), which are subject to standards that require disposal in special centres (see the User Manual).

(For SW900 P)

- While the engine is running, the silencer warms up; do not touch the silencer when it is hot to avoid burns or fires.
- Running the engine with an insufficient quantity of oil can seriously damage the engine. Check the oil level with the engine off and the machine on a level surface.
- Never run the engine if the air filter is not installed, because the engine could be damaged.
- Technical service procedures on the engine must be performed by an authorised Dealer.
- Only use original spare parts or parts of matching quality for the engine. Using spare parts of lower quality can seriously damage the engine.
- See also the SAFETY RULES in the Engine Manual, which is to be considered an integral part of this Manual.
- Pay attention to hot parts when working near the engine and the muffler.

(For SW900 B)

- Before using the battery charger, ensure that frequency and voltage values, indicated on the machine serial number plate, match the electrical mains voltage.
- Do not pull or carry the machine by the battery charger cable and never use the battery charger cable as a handle. Do not close a door on the battery charger cable, or pull the battery charger cable around sharp edges or corners. Do not run the machine on the battery charger cable.
- Keep the battery charger cable away from heated surfaces.
- Do not use the machine if the battery charger cable or plug is damaged. If the machine is not working as it should, has been damaged, left outdoors or dropped into water, return it to the Service Center.
- Before performing any maintenance procedure, disconnect the battery charger cable from the electrical mains to avoid any risk of fire, electric shock or injuries.
- Do not smoke while charging the batteries.

Machine Lifting



Warning! Do not work under the lifted machine, if it is not securely fixed.

Machine Transportation



Warning! Before transporting the machine, make sure that:

All covers are closed.

(For SW900 B) The battery connector is disconnected.

The machine is securely fastened to the means of transport.

Machine Nomenclature (SW900 B) (know your machine)

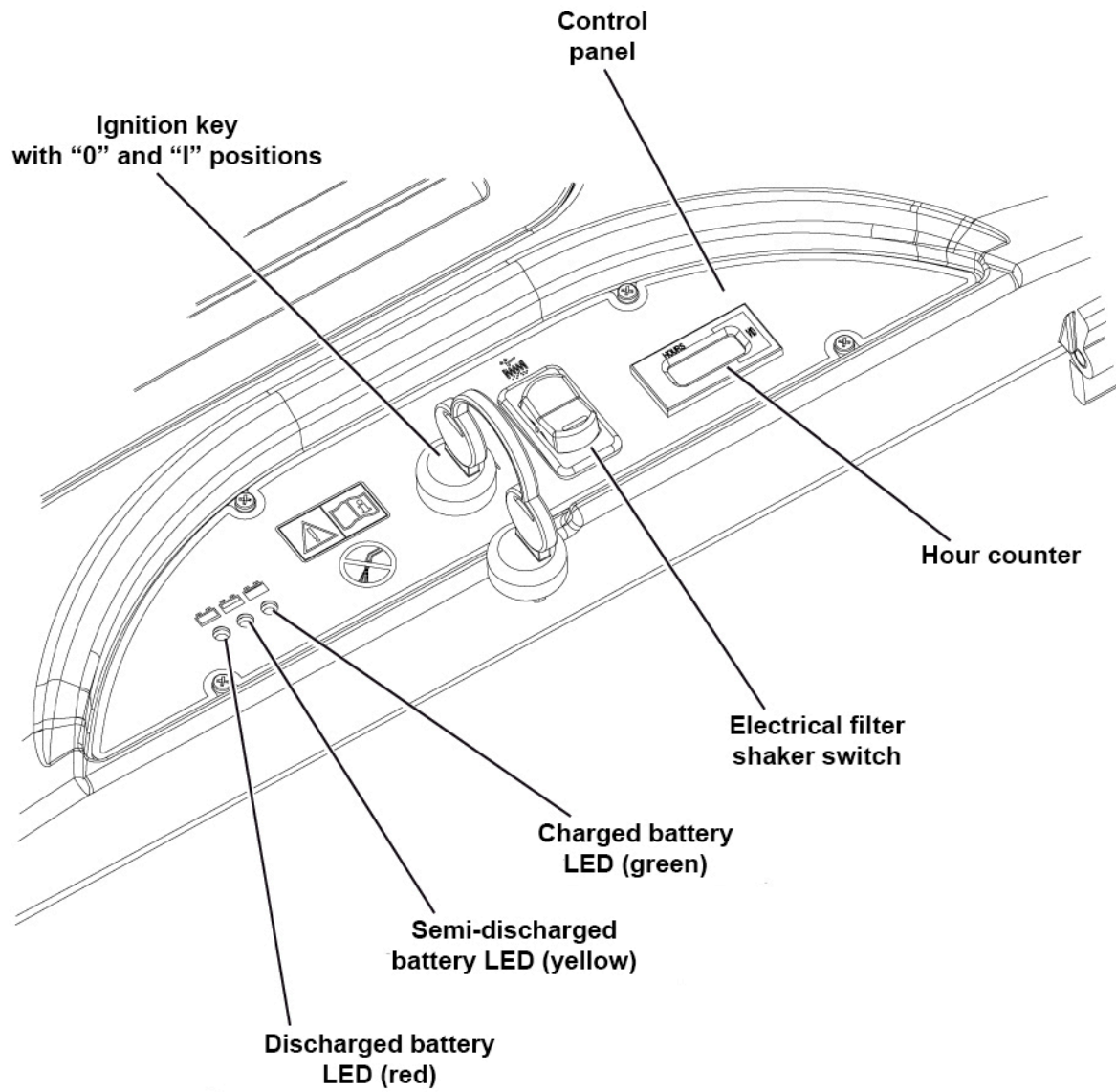

Machine Nomenclature (SW900 B) (Continues)

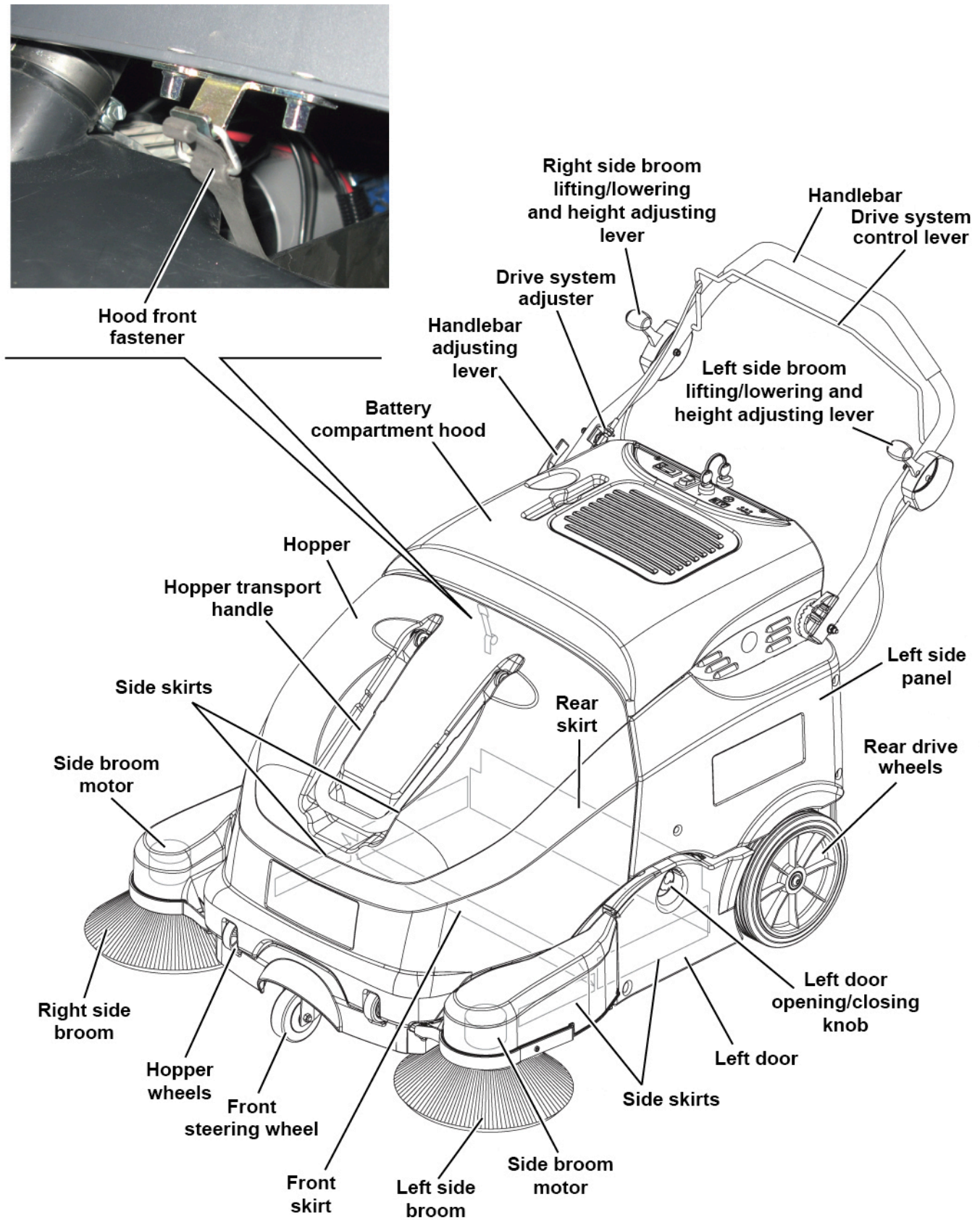

Machine Nomenclature (SW900 B) (Continues)

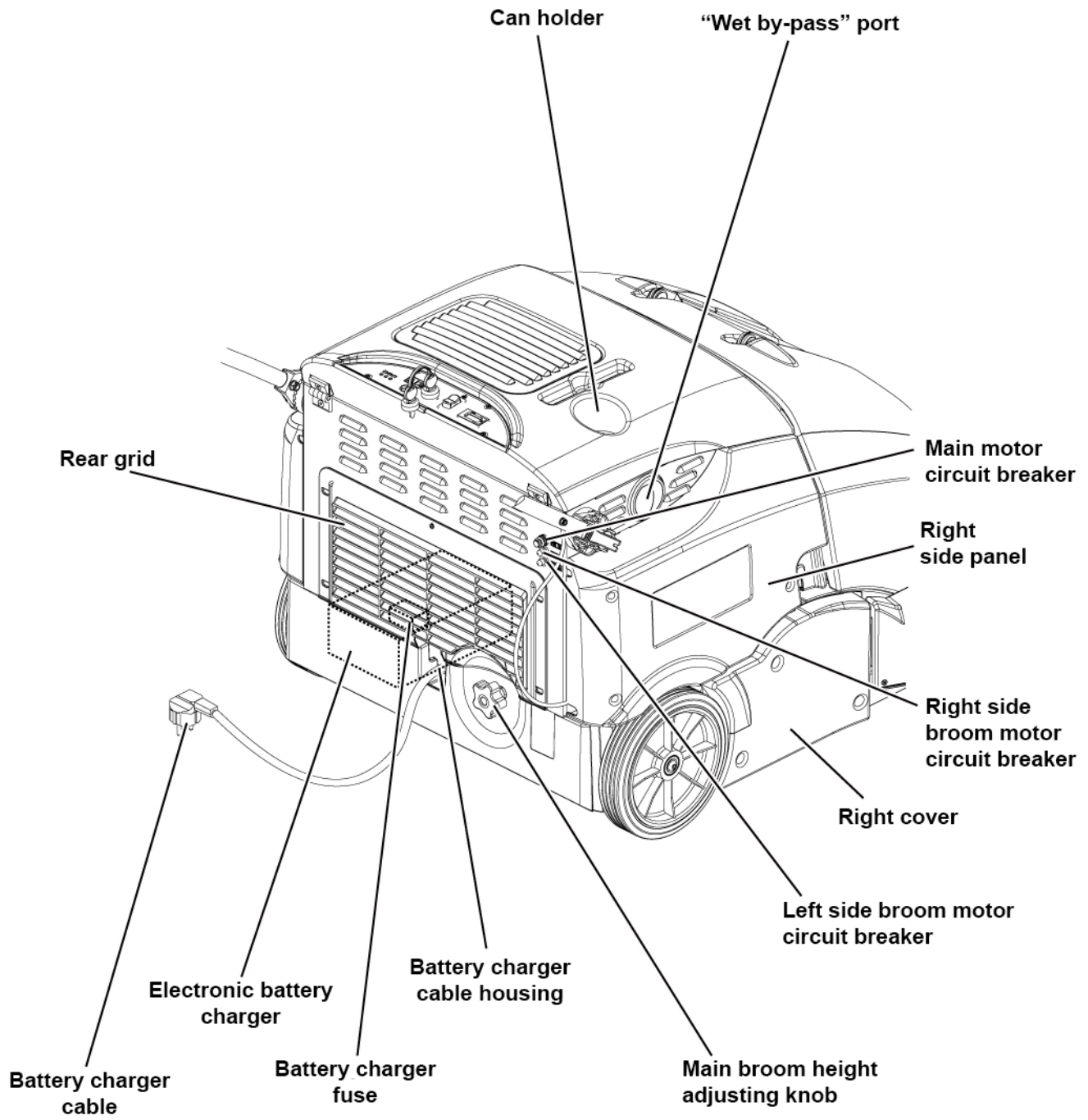

Machine Nomenclature (SW900 B) (Continues)

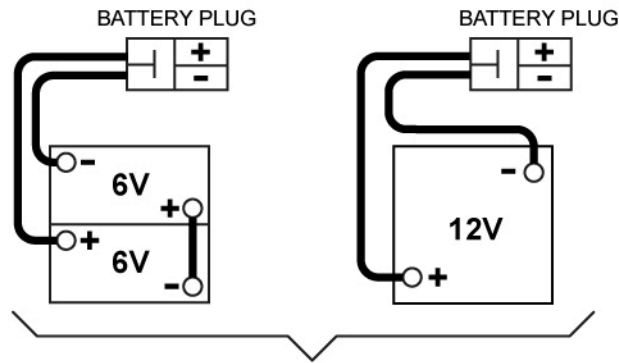

Battery connection diagram

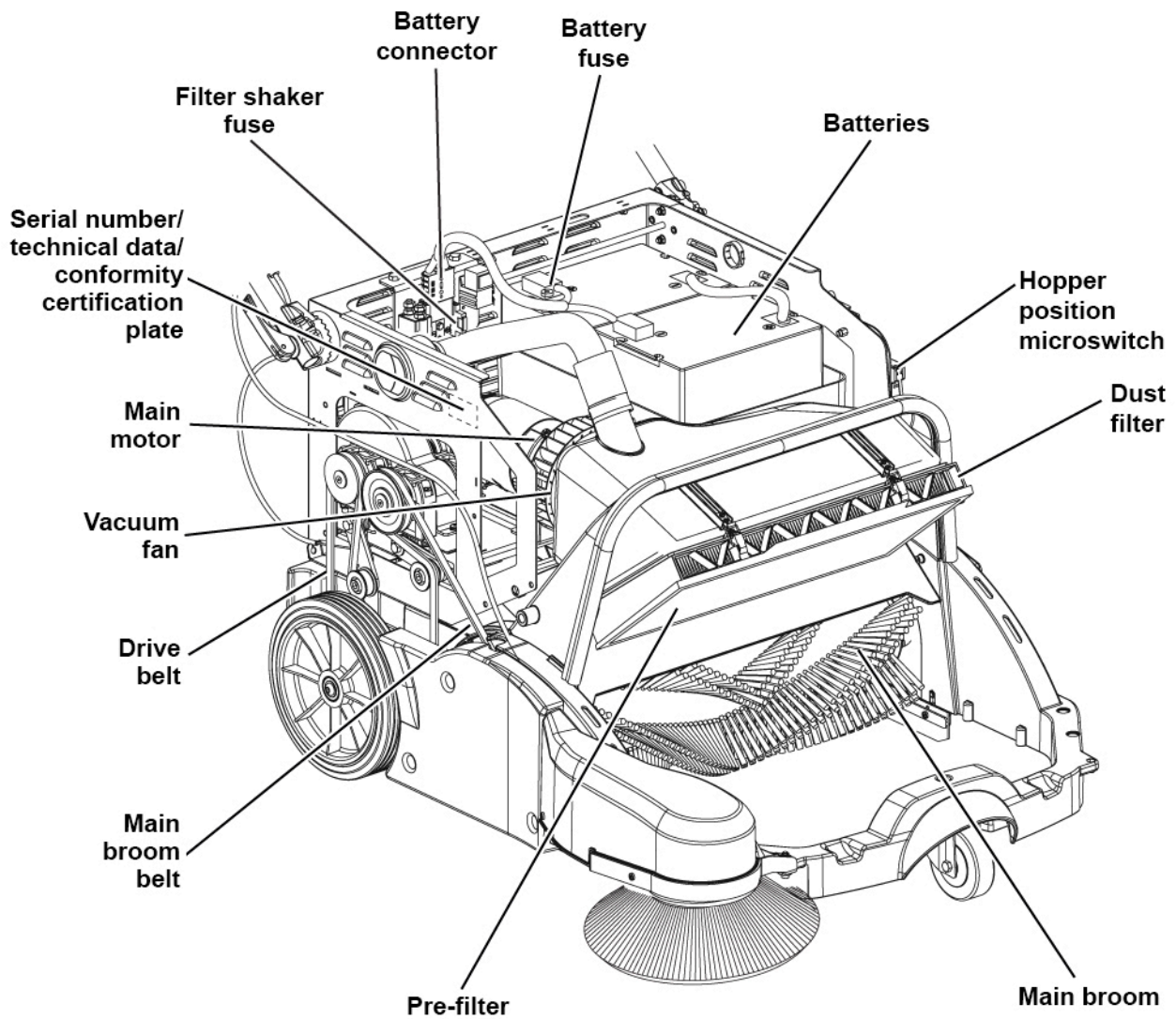

Machine Nomenclature (SW900 P) (know your machine)

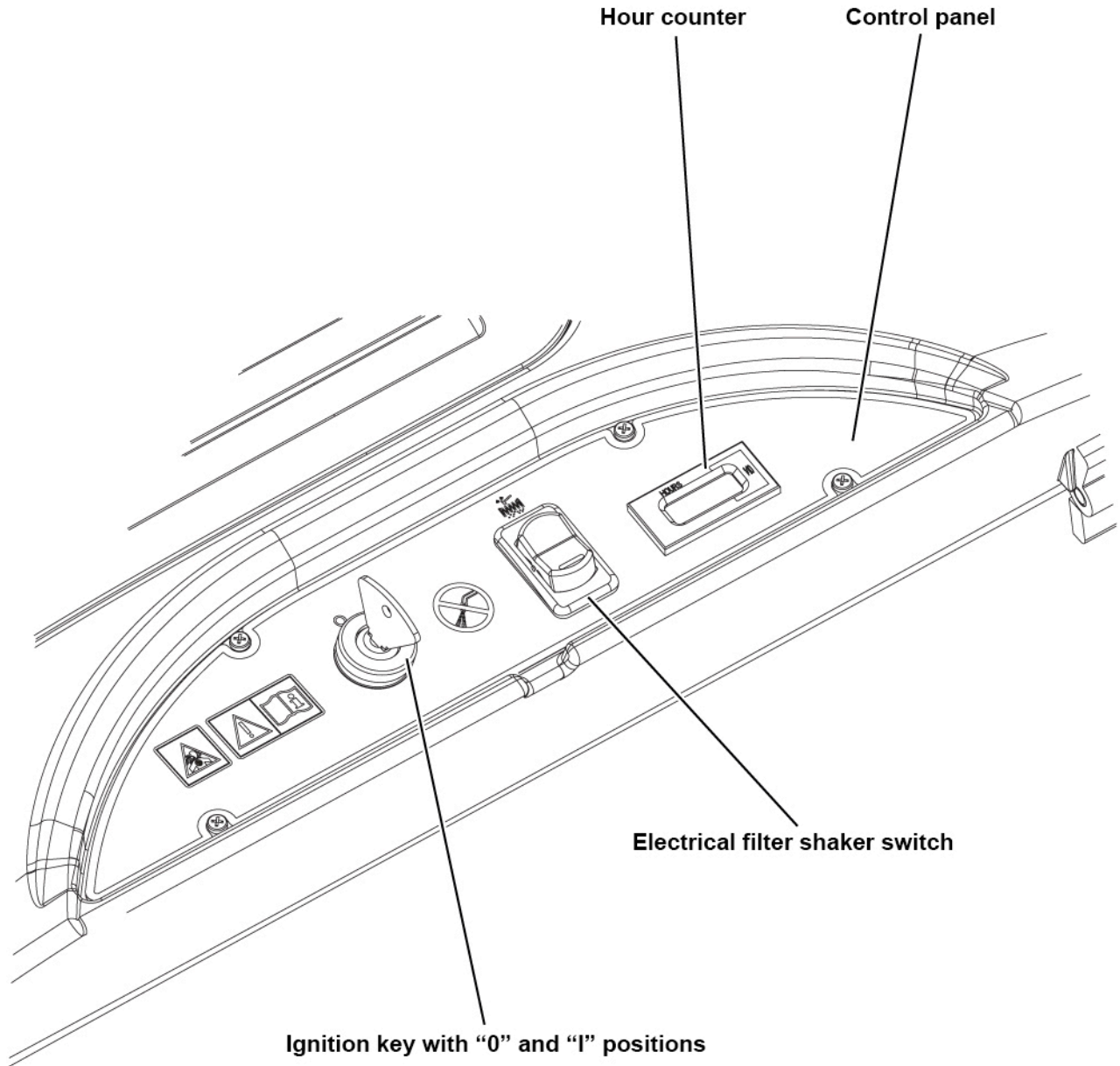

Machine Nomenclature (SW900 P) (Continues)

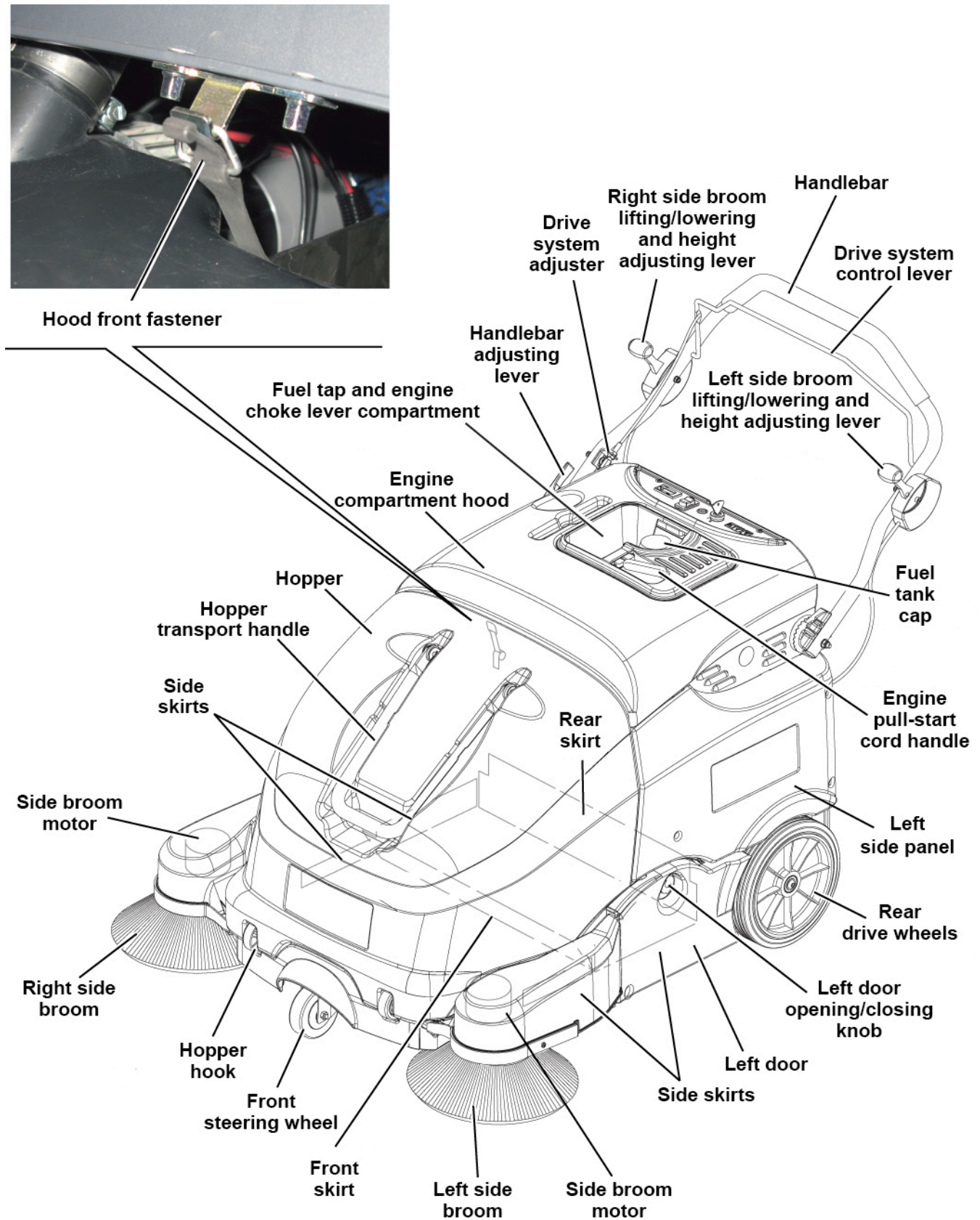

Machine Nomenclature (SW900 P) (Continues)

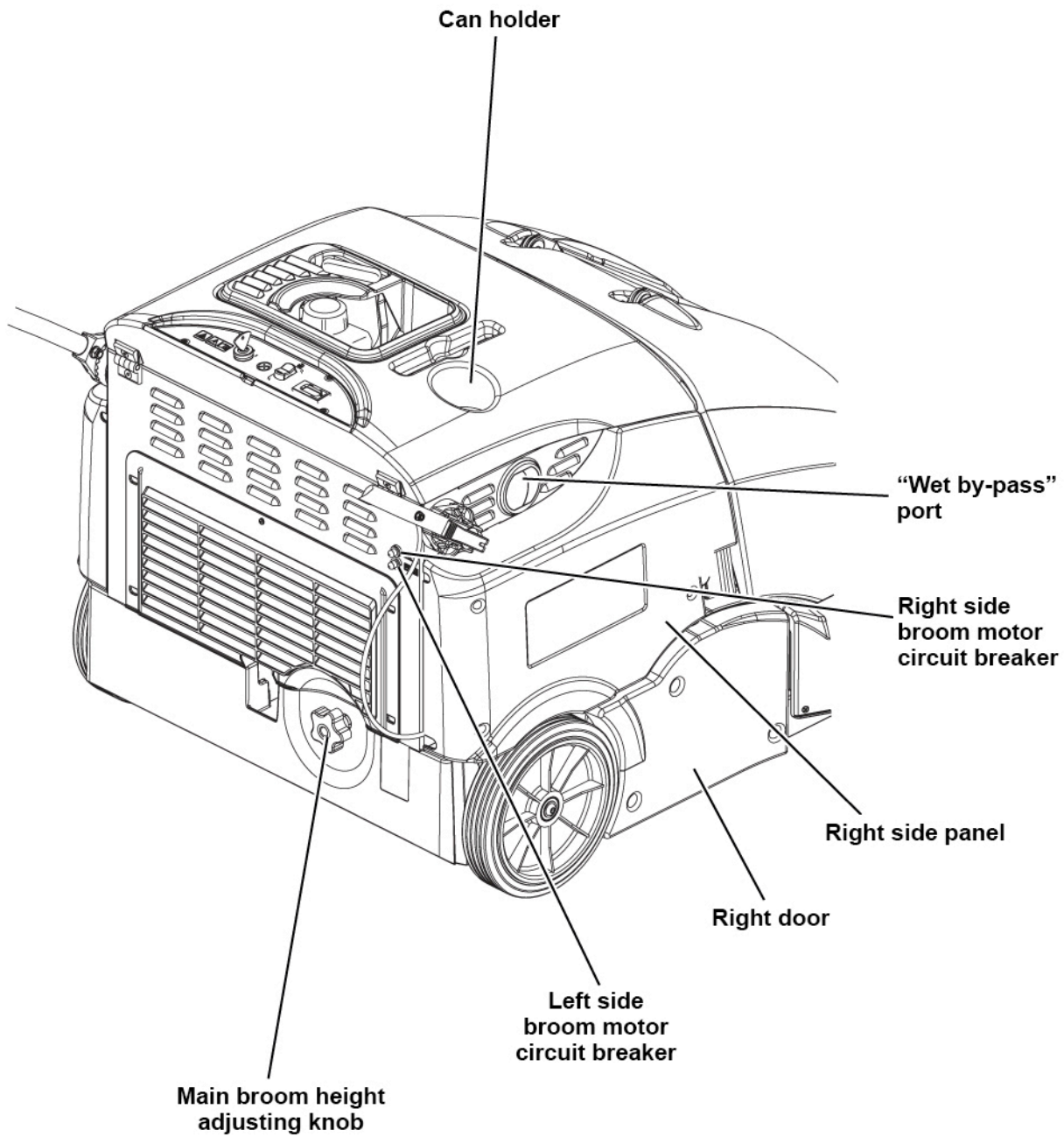

Machine Nomenclature (SW900 P) (Continues)

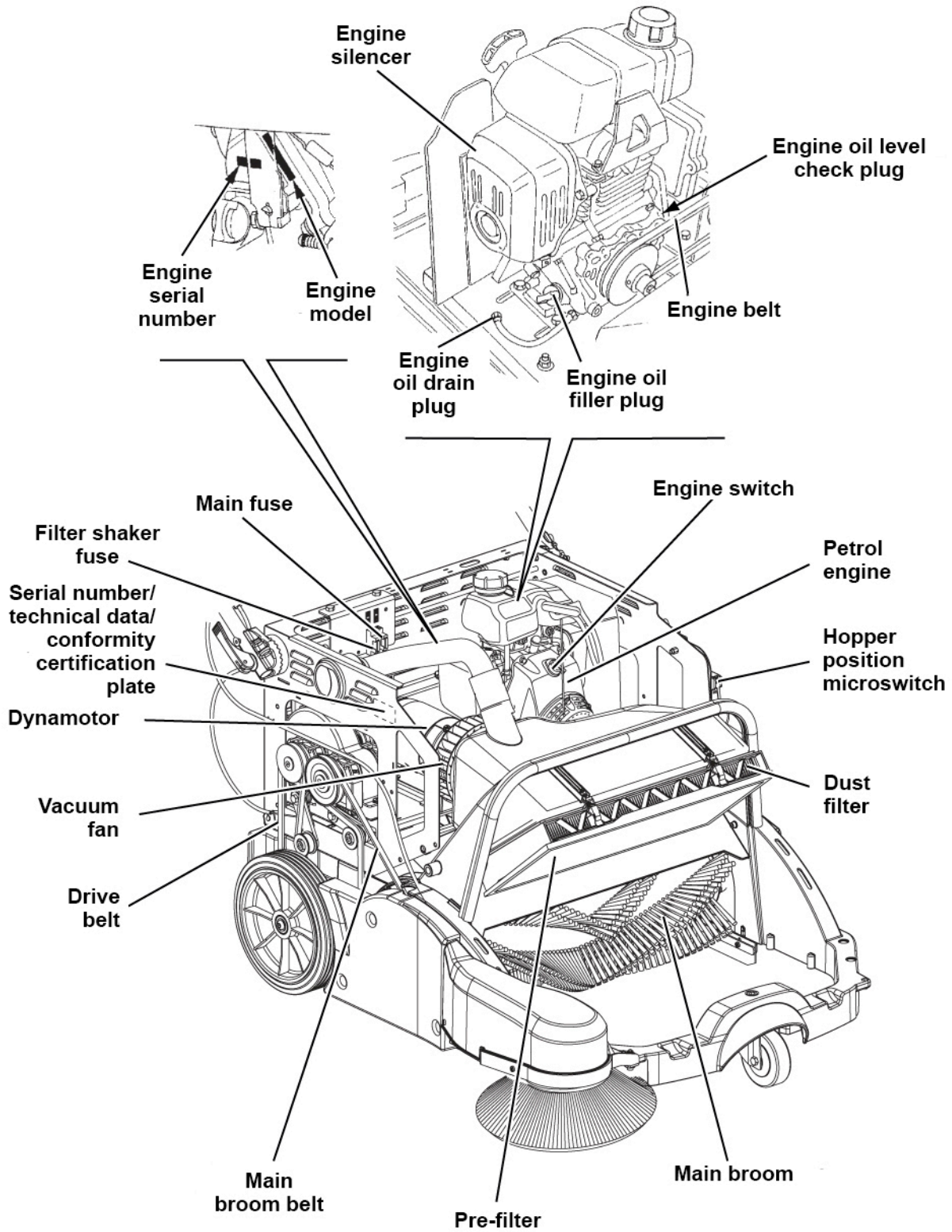

Service and Diagnostic Equipment

Besides a complete set of standard meters, the following instruments are necessary to perform fast checks and repairs on Nilfisk-Advance machines:

- Digital Volt Meter (DVM)
- Amp clamp with possibility of making DC measurements
- Battery charge tester to check 12V batteries
- Static control wrist strap
- Dynamometric wrench set
- A copy of the User Manual and Spare Parts List of the machine to be serviced (provided with the machine or available at www.advance-us.com or other Nilfisk-Advance websites).

The following equipment is also available at Nilfisk-Advance Centers.

Technical Data

Model		Advance / Nilfisk SW900 B	Nilfisk SW900 P
Cleaning width	with one side broom	32.5 in (825 mm)	
	with two side brooms	41.3 in (1,050 mm)	
Main broom size (length x diameter)		23.6 x 10.4 in (600 x 265 mm)	
Side broom diameter		12.4 in (315 mm)	
Theoretical working capacity	with one side broom	39.987 ft ² /h (3.715 m ² /h)	
	with two side brooms	50.859 ft ² /h (4.725 m ² /h)	
Hopper	capacity	2.1 ft ³ (60 Liters)	
	maximum transportable weight	66 lb (30 kg)	
Filter	cleaning system	Electrical filter shaker (manual on Advance version)	
	area	20.5 ft ² (1.9 m ²)	
	filtering capacity	5-10 µm	
Power		12V batteries	-
Power		-	2.1 kW @ 3,600 rpm
Engine model		-	Honda GX-100
Fuel tank capacity			0.77 liters
Main motor	power (drive/main broom/vacuum system)	0.9 hp (680 W)	-
Dynamotor	power (drive/main broom/vacuum system)	-	0.26 hp (198 W)
Main broom	speed	420 rpm	
Side broom	motor power	0.05 hp (40 W)	
	speed	100 rpm	
Drive	forward speed	2.8 mi/h (4.5 km/h)	
Maximum gradient when working		2 %	
Filter shaker motor		12 W	
Total absorbed power		67A (0.8 kW)	-
Working autonomy		3 h	1.5 h
Dimensions (length x width x height)	machine running	54.7 x 34.2 x 43.3 in (1,390 x 870 x 1,100 mm)	
	machine with folded handlebar	41.3 x 34.2 x 33 in (1,050 x 870 x 840 mm)	
	machine with two side brooms	54.7 x 37.4 x 43.3 in (1,390 x 950 x 1,100 mm)	
	battery compartment	12.9 x 9 x 15 in (327 x 230 x 380 mm)	

Technical Data (Continues)

Model		Advance / Nilfisk SW900 B	Nilfisk SW900 P
Weight	kerb weight without batteries	181 lb (82 Kg)	194 lb (88 Kg)
	total kerb weight	315 lb (143 Kg)	195 lb (88.5 Kg)
	gross vehicle weight (GVW)	388 lb (176 Kg)	269 lb (122 Kg)
Wheel specific pressure on the floor (front - rear wheels, in running conditions)		301 - 72 psi (2.1 - 0.5 N/mm ²)	
Sound pressure level at workstation (ISO 11201, ISO 4871, EN 60335-2-72) (LpA)		70 ± 3 dB(A)	78 ± 3 dB(A)
Machine sound pressure level (ISO 3744, ISO 4871, EN 60335-2-72) (LwA)		84 dB(A)	93 dB(A)
IP protection class		X3	
U-turn space		61 in (1,550 mm)	
Vibration level at the operator's arms (ISO 5349-1) (**)		< 98 in/s ² (< 2.5 m/s ²)	157 in/s ² (4 m/s ²)

(*) Machines have been tested under the following conditions:

- Battery maximum size
- Brooms of maximum size
- Full hopper
- Optional components installed
- Weight on wheels checked
- Print on the floor checked on cement for each single wheel

Result expressed as maximum value for both front and rear wheels

(**) Under normal working conditions, on a level asphalt surface.

Machine Material Composition and Recyclability

Type	Recyclable percentage	SW900 B weight percentage	SW900 P weight percentage
Aluminium	100 %	2.4 %	2.2 %
Electric motors - various	29 %	11.8 %	18.8 %
Ferrous materials	100 %	39.4 %	35.5 %
Wiring harnesses	80 %	1.8 %	1.6 %
Liquids	100 %	0.0 %	1.1 %
Plastic - non-recyclable material	0 %	9.4 %	8.6 %
Plastic - recyclable material	100 %	27.1 %	24.7 %
Polyethylene	92 %	5.9 %	5.4 %
Rubber	20 %	2.4 %	2.2 %

Dimensions

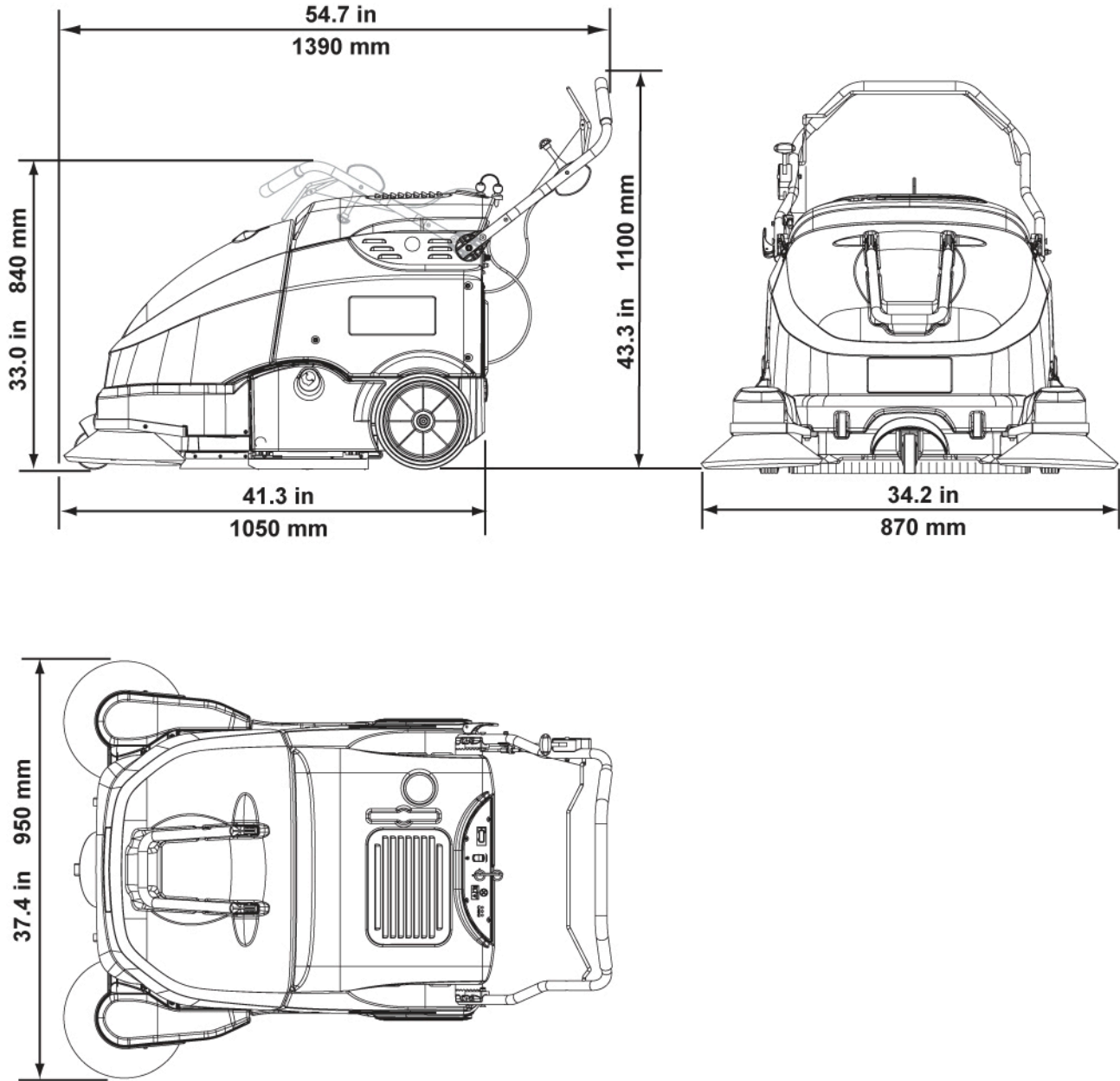

Maintenance

The lifespan of the machine and its maximum operating safety are ensured by correct and regular maintenance.



Warning! *Read carefully the instructions in the Safety chapter before performing any maintenance procedure.*

The following tables provides the scheduled maintenance. The intervals shown may vary according to particular working conditions, which are to be defined by the person in charge of the maintenance. For instructions on maintenance procedures, see the following paragraphs.

Scheduled Maintenance Table (SW900 B)

Procedure	Upon delivery	Every 10 hours	Every 50 hours	Every 200 hours	Every 400 hours
Battery charging	(1)				
Battery (WET) fluid level check					
Battery charger cable check					
Dust filter cleaning and integrity check		(2)			
Side and main broom height check and adjustment					
Skirt height and operation check					
Dust filter holder gasket check					
Electrical filter shaker operation check					
Drive belt check/adjustment: drive system, main broom.					
Hopper position microswitch operation check					
Drive belt replacement: drive system, main broom.					
Main motor carbon brush check and replacement					

(1) Daily or after using the machine.

(2) Or before use.

Scheduled Maintenance Table (SW900 P)

Procedure	Upon delivery	Every 10 hours	Every 50 hours	Every 100 hours	Every 200 hours	Every 300 hours
Engine oil level check		(1) (5)				
Engine air filter check		(1) (5)				
Dust filter cleaning and integrity check		(1)				
Side and main broom height check and adjustment						
Skirt height and operation check						
Electrical filter shaker operation check						
Engine air filter cleaning				(3) (5)		
Drive belt tensioner adjustment				(1)		
Drive belt check/adjustment: engine, drive system, main broom						
Engine Oil Change				(2) (5) (6)		
Spark plug check/cleaning				(5)		
Fuel tank and filter cleaning				(4) (5)		
Engine speed check						
Dust filter holder gasket check						
Engine air filter replacement					(3) (5)	
Spark plug replacement					(2) (5)	
Valve clearance check/adjustment					(4) (5)	
Hopper gasket integrity check						
Hopper position microswitch operation check						
Drive belt replacement: engine, drive system, main broom						
Dynamotor carbon brush check and replacement						
Engine combustion chamber cleaning						(4) (5)
Fuel hose check	(4) (5) Every two years					

- (1) Or before use.
- (2) Or every year.
- (3) Or more often in dusty areas.
- (4) Maintenance procedures to be performed by an authorised Honda Dealer, unless the operator has the service equipment and data, and is qualified to perform such procedures.
- (5) For the relevant procedure, see the Petrol Engine Manual.
- (6) The first time after 20 hours or after one month.

Frame System

Frame (main parts)

- Technopolymer main frame
- Front element anchoring rear wheels
- Rear metal frame
- Engine/battery and drive system holder
- Center element supporting filter and main broom
- Front element supporting hopper, steering wheel and side brooms

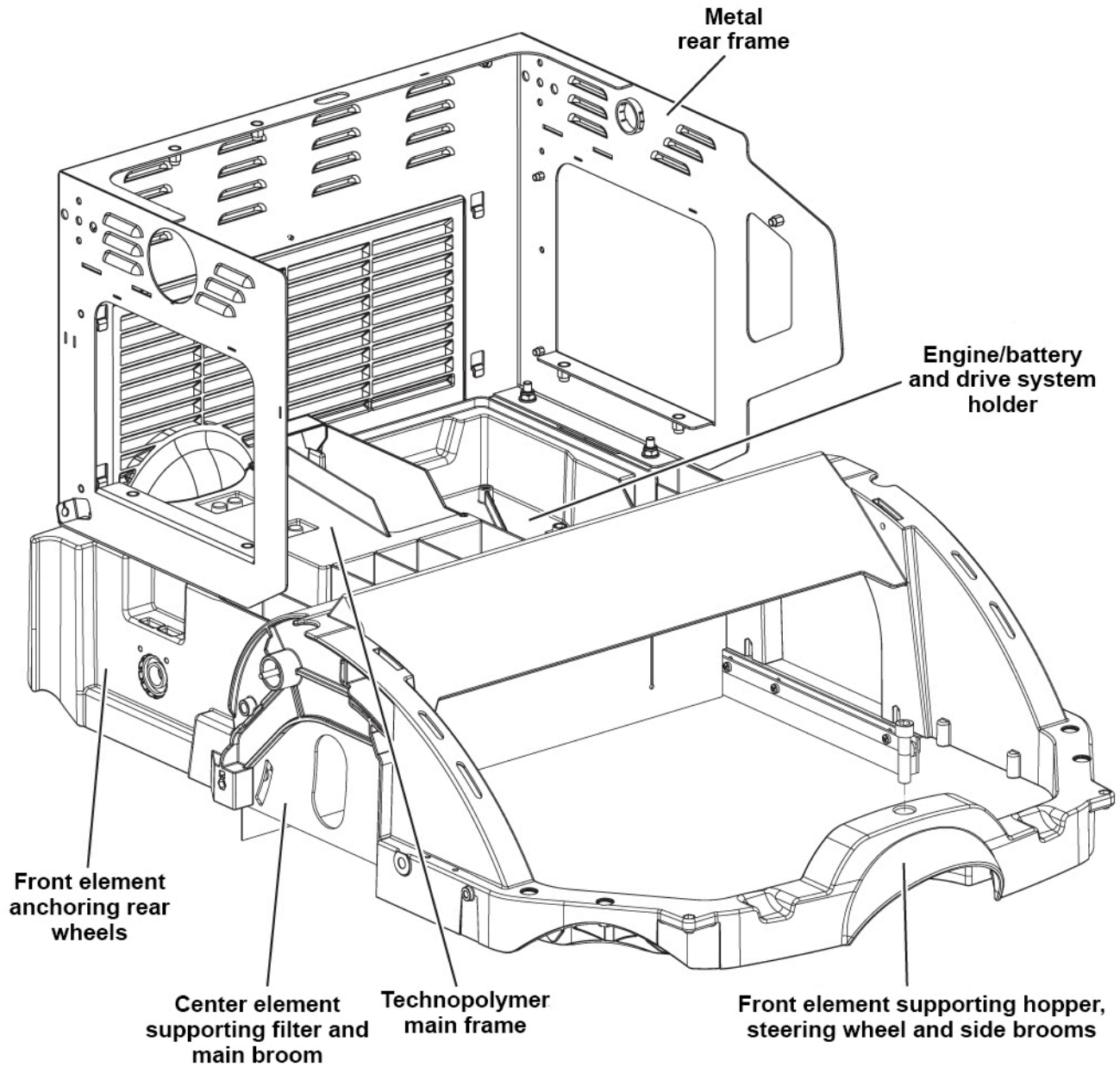

P200260

Dust Control System

Functional Description

The dust generated in the compartment of the main broom is drawn toward the filter from a air flow generated by the fan on main motor (Battery version) or dynamotor (Petrol version).

The filter located between the vacuum system and the hopper, retain dirt which is then discharged into the hopper itself.

The operation of the system depends on the activation of the machine and the main broom.

The vacuum system consists of a fan installed on the main motor / dynamotor which is powered by the relay (K0) (see Electrical and Control System chapter).

VERSION WITH ELECTRICAL FILTER SHAKER

The electric filter shaker system consists of a motor (M1) which is powered by the relay (K1) and protected by the fuse (F1) (see Electrical and Control System chapter).

VERSION WITH MANUAL FILTER SHAKER

By operating on the lever on the right side of the machine, a rake acts mechanically on the filter fins allowing dirt trapped in the folds of the same to fall by gravity into the hopper.

Wiring Diagram (SW900 B with electric filtershaker)

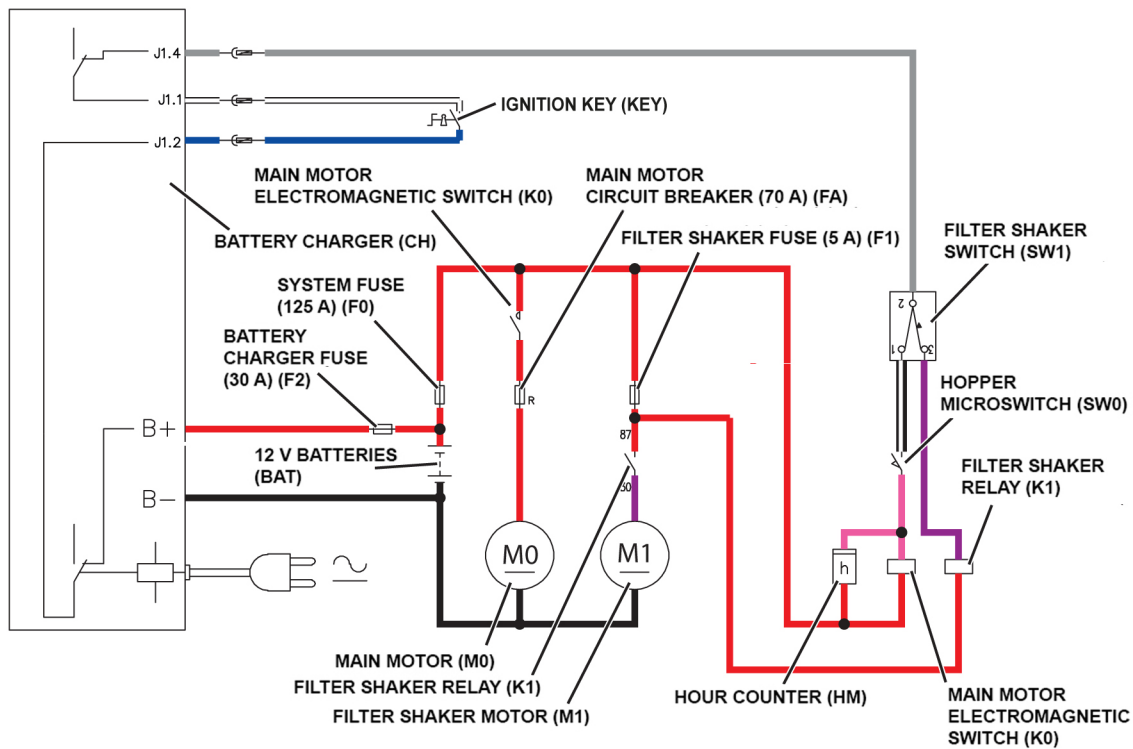

Wiring Diagram (SW900 B with manual filtershaker)

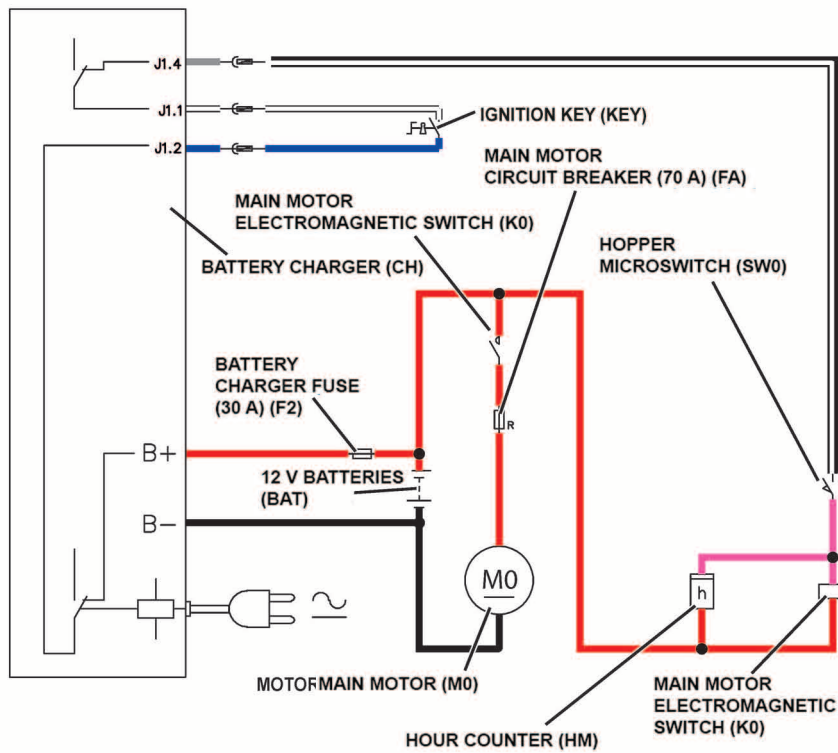

P200261

Wiring Diagram (SW900 P)

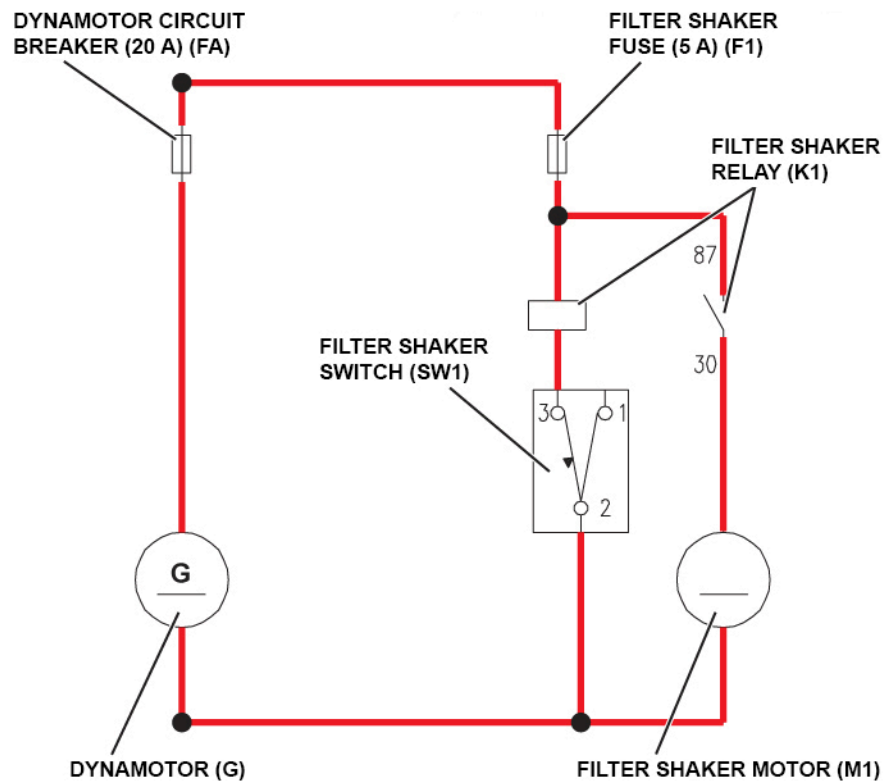

P200262

Component Locations

- Main motor (SW900 B)
- Dynamotor (SW900 P)
- Filter and pre-filter panel
- Gaskets
- Filter shaker (M1)
- Fuse (F1) 5A
- Relay (K1)

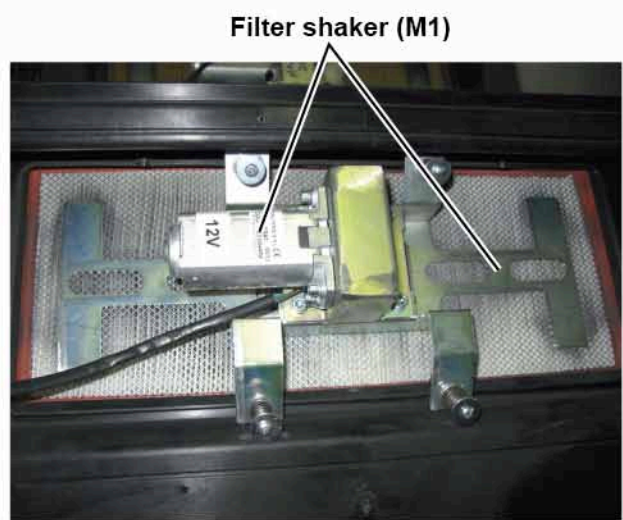
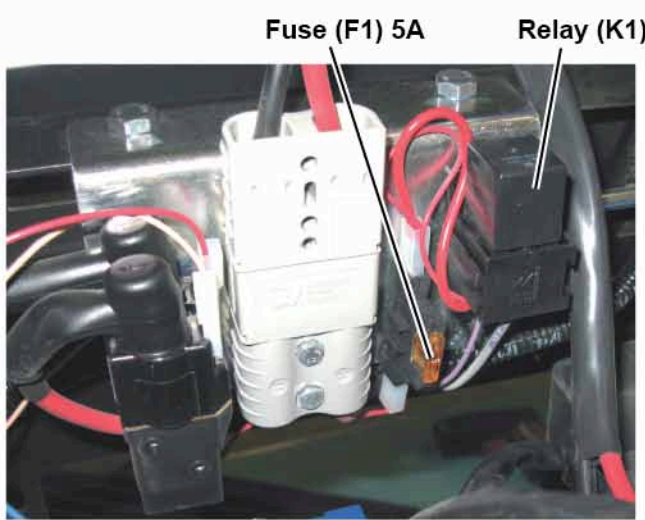

Main motor (SW900 Battery)
Dynamotor (SW900 Petrol)

Filter and pre-filter panel

Gaskets

Maintenance and Adjustments

Panel dust filter, cleaning and integrity check/replacement



Caution! The dust filter must be regularly cleaned to maintain the efficiency of the vacuum system. Follow the recommended filter service intervals for the longest filter life.



Note: Besides the standard polyester filter, paper filters are also available.



Warning! To clean the filter, always wear safety guards (such as safety glasses, dust mask, gloves, etc.) and clean the filter in a well-ventilated area. Take care not to pierce the filter.

1. Drive the machine on a level floor and ensure that it cannot move.
2. Turn the ignition key to “0”.
3. Remove the hopper by using its transport handle and wheels.
4. If equipped, remove the pre-filter (A) after releasing the upper fasteners (B) and then the lower fasteners (C).
5. Disengage the lever fasteners (D) and turn down the filter holder assembly (E) to the end-of-stroke (F).

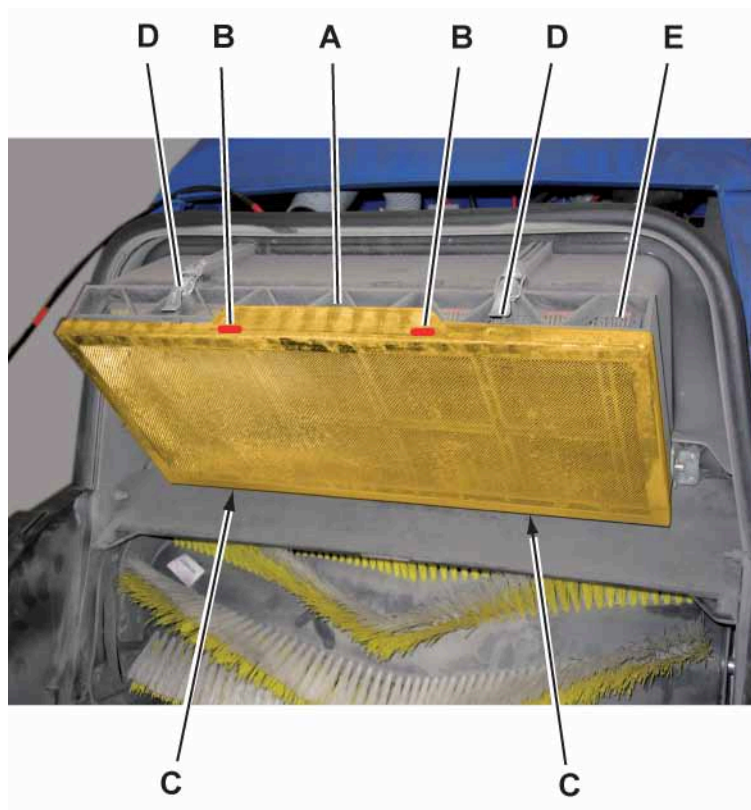

Panel dust filter, cleaning and integrity check/replacement (Continues)

6. Remove the dust filter (G).
7. In an outdoor area, clean the dust filter by shaking it on a level and clean surface, tapping the side (H), opposite to the wire gauze (I).
8. Complete the cleaning with compressed air (J) blowing only from the side of the wire gauze (I) and in perpendicular position as to the gauze itself.
According to the type of filter, observe the following cautions:
 - Polyester filter (standard): For a better cleaning, it is allowed to wash the filter with water and non-lathering detergents. This provides better quality cleaning but reduces the life of the filter, which will have to be replaced more frequently. The use of inadequate detergents can damage the filter.
 - Paper filter (optional): Do not use water or detergents to clean it; the filter can be damaged.
9. Check the filter body for tears.
10. Clean the gasket (K) along its perimeter and check it for integrity. If necessary, replace the filter.
11. Clean the gasket (L) along its perimeter and check it for integrity; if necessary replace it.
12. If equipped, clean also the pre-filter with compressed air (maximum pressure 6 bar)
13. Assemble the components in the reverse order of disassembly.

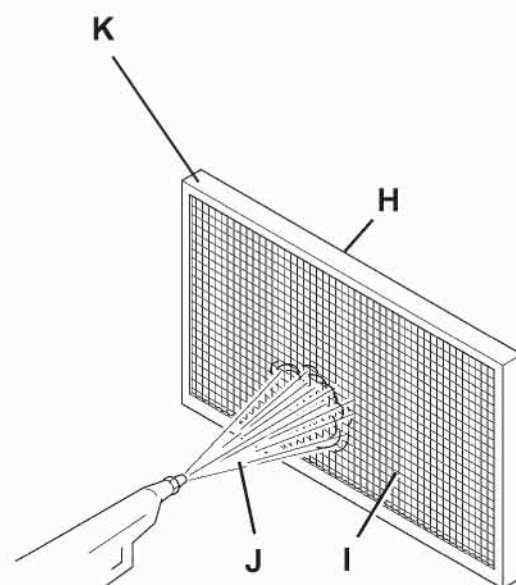

Troubleshooting

Trouble	Possible causes	Remedy
Dust/debris vacuuming is insufficient.	The filter is clogged.	Clean the dust filter by using the filter shaker or by disassembling it.
	The vacuum system compartment gasket is damaged	Repair/replace
No vacuuming. The electrical filter shaker does not work.	The hopper is full.	Empty the hopper.
	The main motor circuit breaker (FA) is open.	Wait for the main motor to cool down, then reset the fuse by pressing the relevant push-button.
	The fuse (F2) is open.	Replace the fuse.
	The relay (K1) is broken.	Replace.
Dust/debris vacuuming is insufficient.	The switch (SW1) is not efficient.	Replace.
	The filter shaker is broken.	Repair/replace.
	The filter is clogged.	Clean the dust filter by using the filter shaker or by disassembling it.
	The vacuum system compartment gasket is damaged	Repair/replace

Removal and Installation

Electrical filter shaker motor amperage check



Warning! *This procedure must be performed by qualified personnel only.*

1. Drive the machine on a level floor and ensure that it cannot move.
2. Turn the ignition key to “0”.
3. Remove the hopper by using its transport handle and wheels.
4. Disengage the front fastener and open the battery/engine hood.
5. Apply the amp clamps (A) on one cable (B) of the filter shaker motor connection wiring harness.
6. Carefully operate and keep operated, the hopper position microswitch (C) (to simulate the presence of the hopper).
7. (For SW900 B) Turn the ignition key to “I”.
(For SW900 P) Turn the ignition key to “I” and start the petrol engine.
8. Carefully activate the electrical filter shaker switch (D) and check that the electrical filter shaker motor amperage is between 3 and 4A at 12V.
9. Release the electrical filter shaker switch (D).
10. Turn the ignition key to “0”.
11. Remove the amp clamps (A).

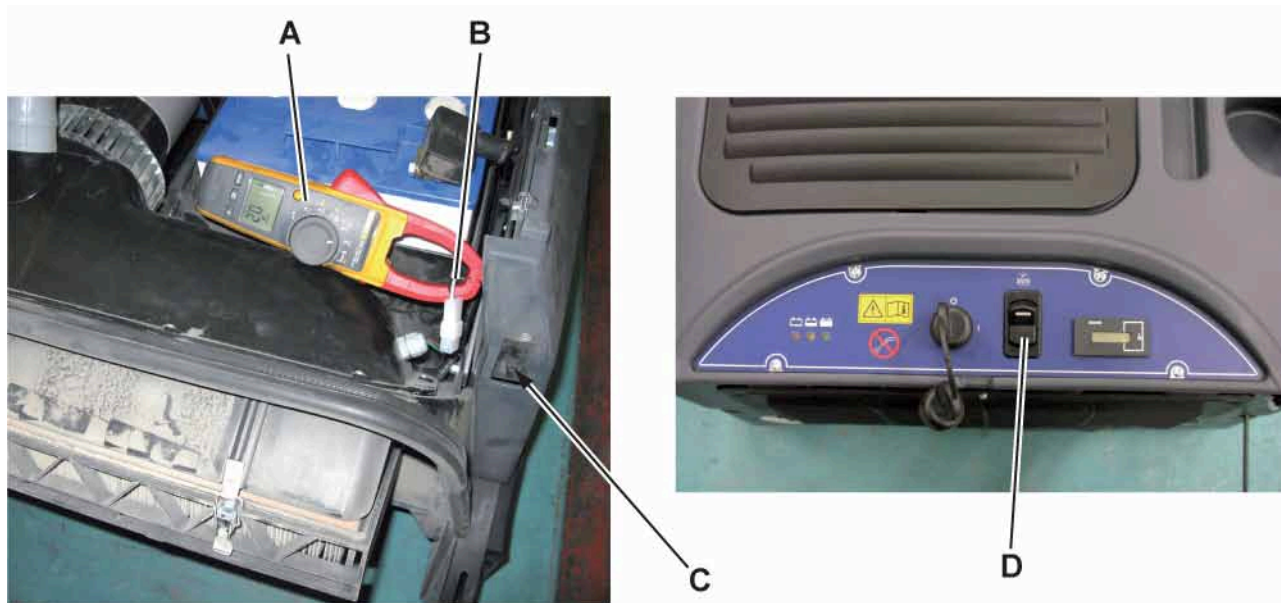

Electrical filter shaker motor amperage check (Continues)

12. If the amperage is higher, perform the following procedures to detect and correct it:
 - Check that the relevant fuse (F1) 5A is properly positioned.
 - Remove the electric filter shaker motor (see the procedure in the next paragraph), and check the condition of all its components. Before removing the filter shaker motor (E), check that the filter shaker frame (F) can slide on the spacer bushes of the springs (G), overcoming the resistance of the springs and that it is not locked.
 - If the above-mentioned procedures do not produce the correct readings for the electrical filter shaker motor amperage, the motor must be replaced (see the procedure in the relevant paragraph).
13. Close the battery/engine compartment hood and engage the front fastener.
14. Reinstall the hopper.
15. Turn the ignition key to “0”.

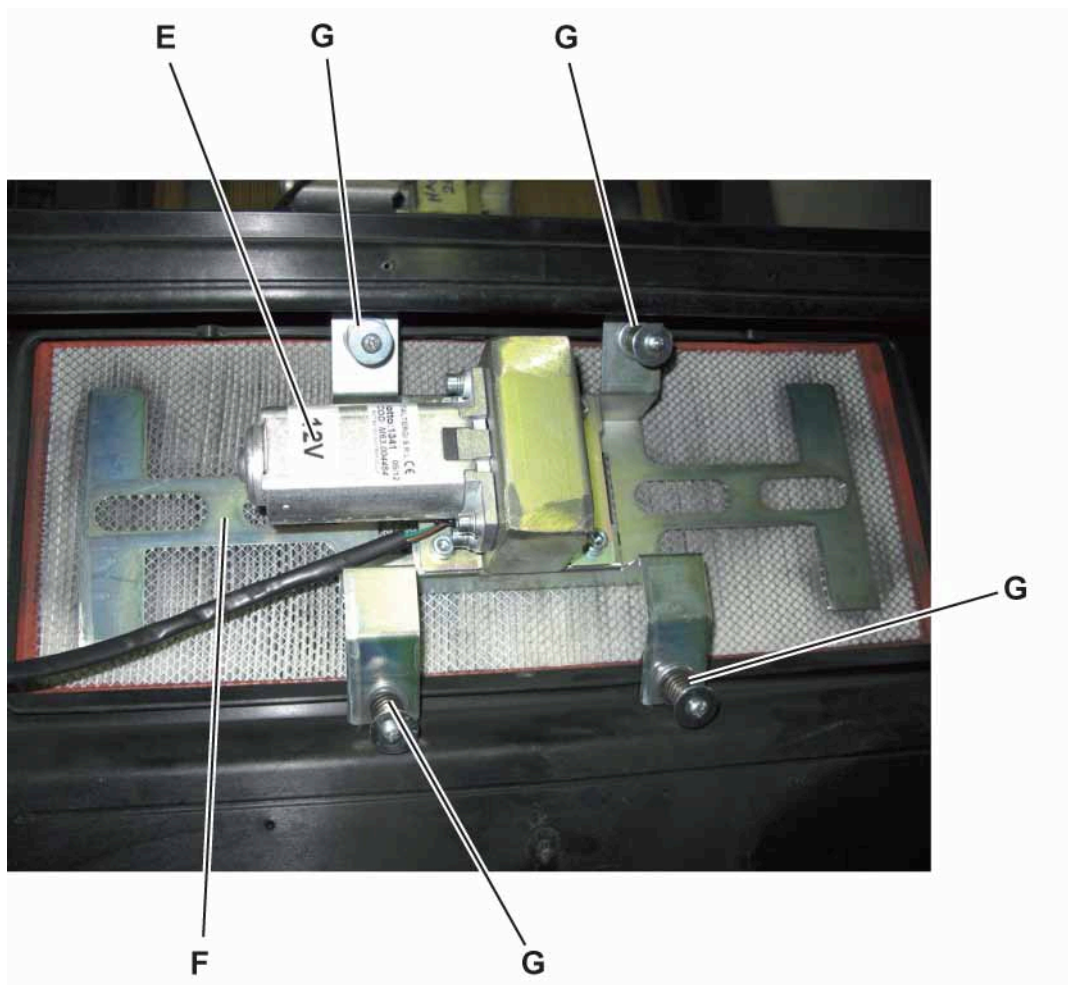

Electrical Filter Shaker Motor Disassembly/Assembly

Disassembly

1. Drive the machine on a level floor and ensure that it cannot move.
2. Turn the ignition key to “0”.
3. Remove the hopper by using its transport handle and wheels.
4. Disengage the front fastener and open the battery/engine hood.
5. (For SW900 B) Remove the batteries and their container (see the procedure in the relevant paragraph).
6. Disconnect the “wet by-pass” hoses (A) from the deflector (B).
7. Remove all the mounting screws (C) of the deflector (B).
8. Move aside the conveyor (B).



Electrical Filter Shaker Motor Disassembly/Assembly (Continues)

9. Disconnect the filter shaker connector (N).
10. For disassembling the filter shaker motor (E) only, remove the four screws (F), then remove it from its housing by disengaging the inner eccentric (F).
The eccentric (F) must be firmly locked on the shaft of the filter shaker motor.
For the complete removal of the motor (E), it is necessary to disconnect the semiconnector out of its wiring harness (L).
11. For disassembling the motor (E) with the holder (O), remove the four screws (P).
12. For disassembly of the motor (E) with its of the frame (G) electrical filter shaker, remove the screws (H) and recover the springs (I), the washers (J) and the spacer bushes (K).
Check the integrity of the disassembled parts.

Assembly

13. Assemble the components in the reverse order of disassembly, and note the following:
 - When reinstalling of the spacer bushes (K) make sure that the same should be flushed with the machine frame and that the slots (M) of the frame (G) slide on spacers (K).
After assembling of the frame (G), check that the frame can slide on the spacer bushes (K) of the springs (I), overcoming the resistance of the springs.

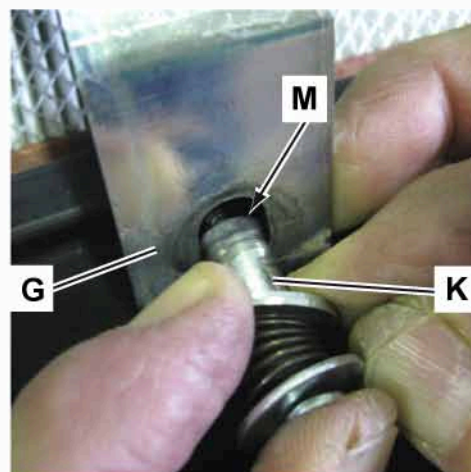
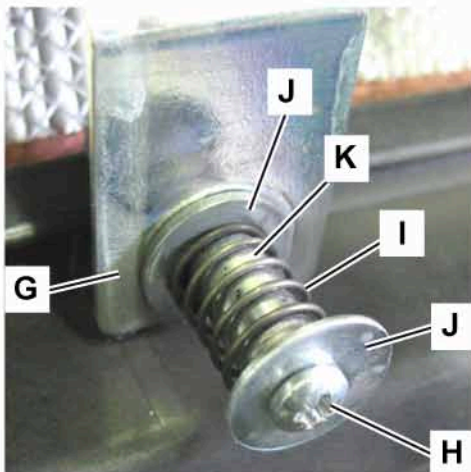
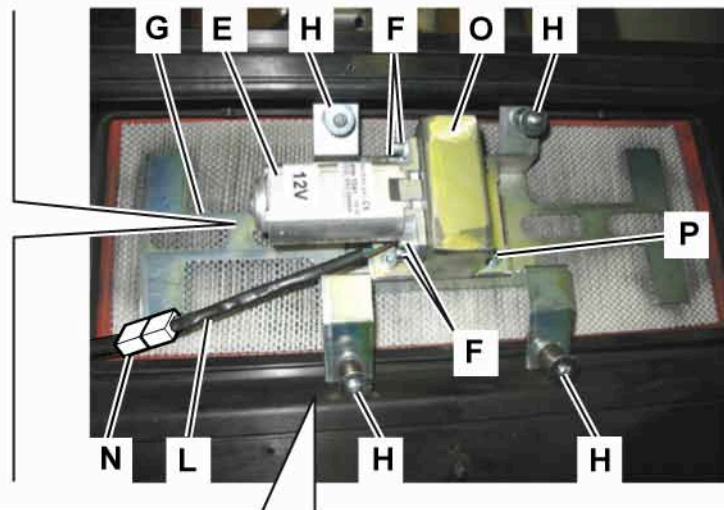
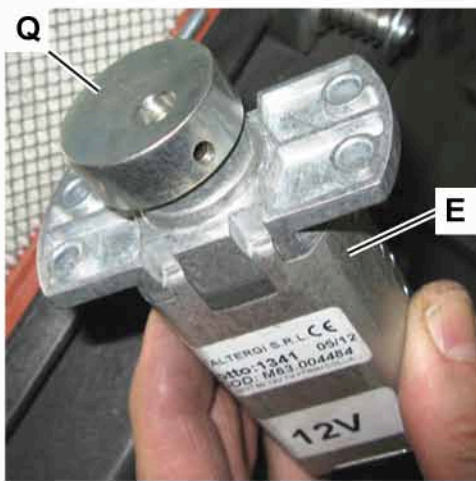

Specifications

Model		Advance / Nilfisk SW900 B	Nilfisk SW900 P
Filter	cleaning system	Electrical filter shaker (manual on Advance version)	
	area	20.5 ft ² (1.9 m ²)	
	filtering capacity	5-10 µm	
Filter shaker motor		12 W	
Paper filter filtering capacity		99% @ 0.8 µm	
Air flow		11301 ft ³ /h (320 m ³ /h)	
Broom compartment vacuum - new filter		0.13 inH ₂ O (3.6 mmH ₂ O)	

Electrical and Control System

Functional Description (SW900 B)

The machine functionality check is mainly performed by the battery charger (CH) that monitors the battery voltage (BAT) (also) during machine operation (not only during recharging).

The ignition key (KEY) provides to the battery charger information about the machine on and off condition.

When the ignition switch (KEY) is closed, the battery charger checks the battery voltage and, if it is insufficient, it activates the electromagnetic switch (K0).

The activation of the electromagnetic switch (K0) is cut off when the battery charger is connected to the electrical mains.

On the same circuit of the electromagnetic switch (K0), there is the hopper safety switch (SW0) which prevents the activation of the electromagnetic switch (K0) if the hopper is not properly positioned, or if the upper hood is open.

For the versions equipped with electrical filter shaker, on the same circuit of the electromagnetic switch (K0) there is the filter shaker switch (SW1). When pressed, it turns off the electromagnetic switch (K0) and activates the relay (K1).

The electromagnetic switch (K0) directly drives the main motor (M0) and the side broom motors (M2) and (M3*), while the relay (K1) (if equipped) turns on the filter shaker motor (M1).

On the circuit of the side broom motors (M2) and (M3*) there are microswitches (SW2) and (SW3*) respectively, which deactivate the relevant motors when the brooms are lifted from the ground by means

of the manual levers on the handlebar.

The display on the control panel shows the battery charge status and the battery charger by means of the LED electronic board (EB1), which is directly connected to the battery charger.

The hour counter (HM) is connected in parallel to the electromagnetic switch (K0) and it counts the operating time of the main motor (M0).

The machine system is connected to the battery with the connector (C1). The battery charger is always connected to the batteries.

* : when the left broom is equipped

Electrical Protections

The main motor (M0) is protected by the 70A circuit breaker (FA).

The side broom motors (M2) and (M3*) are protected by 5A circuit breakers (FB) and (FC*) respectively.

The filter shaker motor circuit (M1) is protected by the 5A fuse (F1).

The battery charger (CH) is protected by the 30A fuse (F2).

The main battery wiring harness is protected by a 125A safety fuse (F0) (on the supported versions).

Functional Description (SW900 P)

The dynamotor (G) provides the current necessary for the activation of the side broom motors (M2) and (M3*), filter shaker circuit (M1) and hour counter (HM).

The ignition key (KEY) turned to “0” inhibits the activation of the engine, when turned to “1” it allows for startup and operation.

When the engine is turned on, the current generated by the dynamotor (G) directly activates the side broom motors (M2) and (M3*).

On the same circuit of the ignition switch (KEY), there is the hopper safety switch (SW0) which prevents the activation of the engine if the hopper is not properly positioned, or if the upper hood is open.

On the versions equipped with electrical filter shaker, the dynamotor (G) powers also the filter shaker switch (SW1) which, when pressed, activates the relay (K1). The relay (K1) turns on the filter shaker motor (M1).

On the circuit of the side broom motors (M2) and (M3*) there are microswitches (SW2) and (SW3*) respectively, which deactivate the relevant motors when the brooms are lifted from the ground by means of the manual levers on the handlebar.

The optional hour counter (HM) is connected to the key circuit (KEY) and is powered by the dynamotor (G) when the engine is running.

Electrical Protections

The dynamotor (G) is protected by the 20A fuse (FA). The side broom motors (M2) and (M3*) are protected by 5A circuit breakers (FB) and (FC*) respectively. The filter shaker motor circuit (M1) is protected by the 5A fuse (F1).

* : when the left broom is equipped

Wiring Diagram

Fuses

Acronym	SW900 B		SW900 P	
	Nominal Size	Protected Function	Nominal Size	Protected Function
F0	125A	BATTERY (BATT)	-	
F1	5A	FILTER SHAKER MOTOR (M1)	5A	FILTER SHAKER MOTOR (M1)
F2	30A	BATTERY CHARGER (CH)	-	-
FA	70A	MAIN MOTOR (M0)	20A	DYNAMOTOR (M0)
FB	5A	RIGHT SIDE BROOM MOTOR (M2)	5A	RIGHT SIDE BROOM MOTOR (M2)
FC	5A	LEFT SIDE BROOM MOTOR (M3)	5A	LEFT SIDE BROOM MOTOR (M3)

Relays / Electromagnetic Switches / Diodes

Acronym	SW900 B	SW900 P
	Activated function	Activated function
K0	MAIN MOTOR (M0)	-
K1	FILTER SHAKER (M1)	FILTER SHAKER (M1)

Wiring Diagram (SW900 B with electric filtershaker)

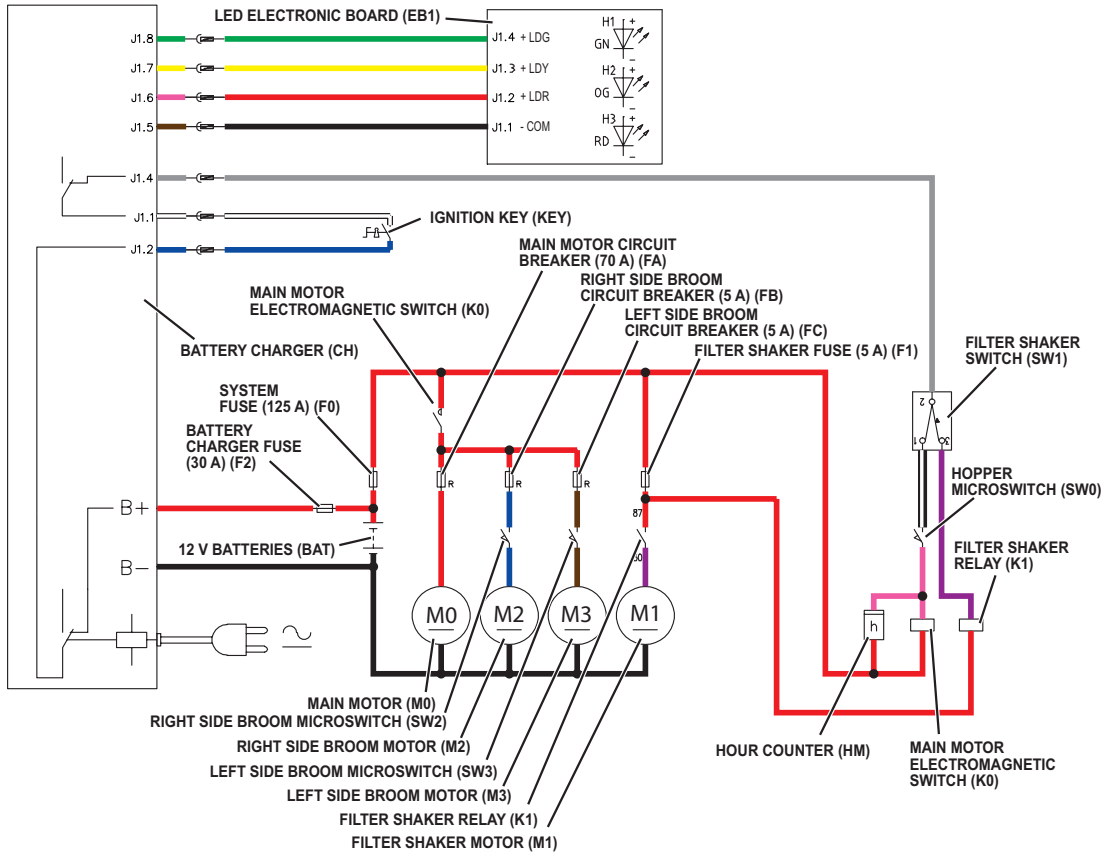

P200306

Wiring Diagram (SW900 B with manual filtershaker)

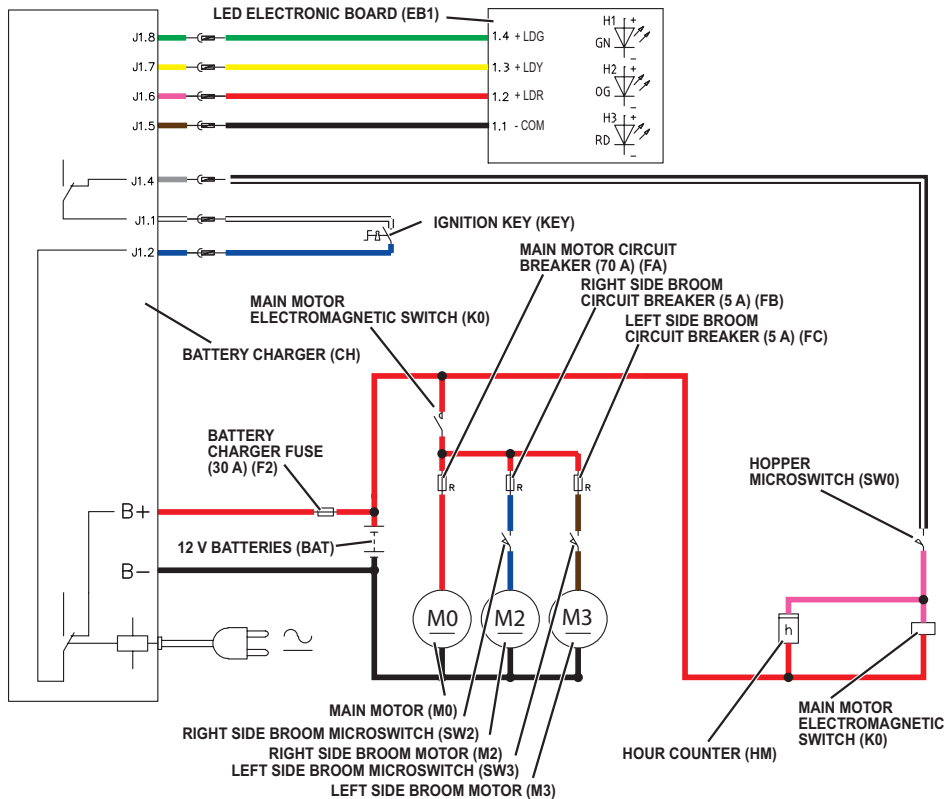

P200306

Wiring Diagram (SW900 P)

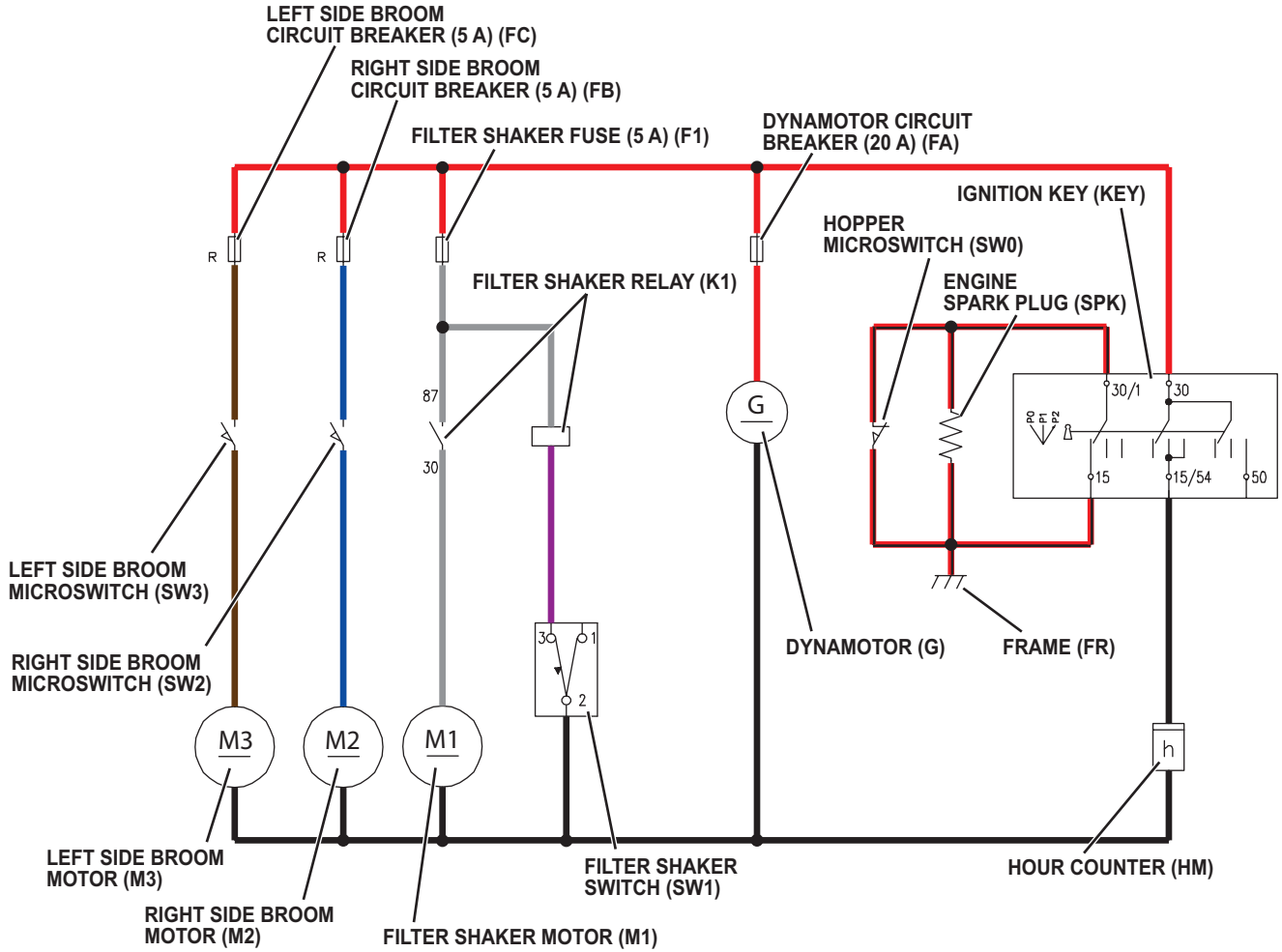

P200307

Component Locations (SW900 B)

- Dashboard
- Ignition key (KEY)
- Filter shaker (SW1)
- Hour counter (HM)
- LED electronic board (EB1)

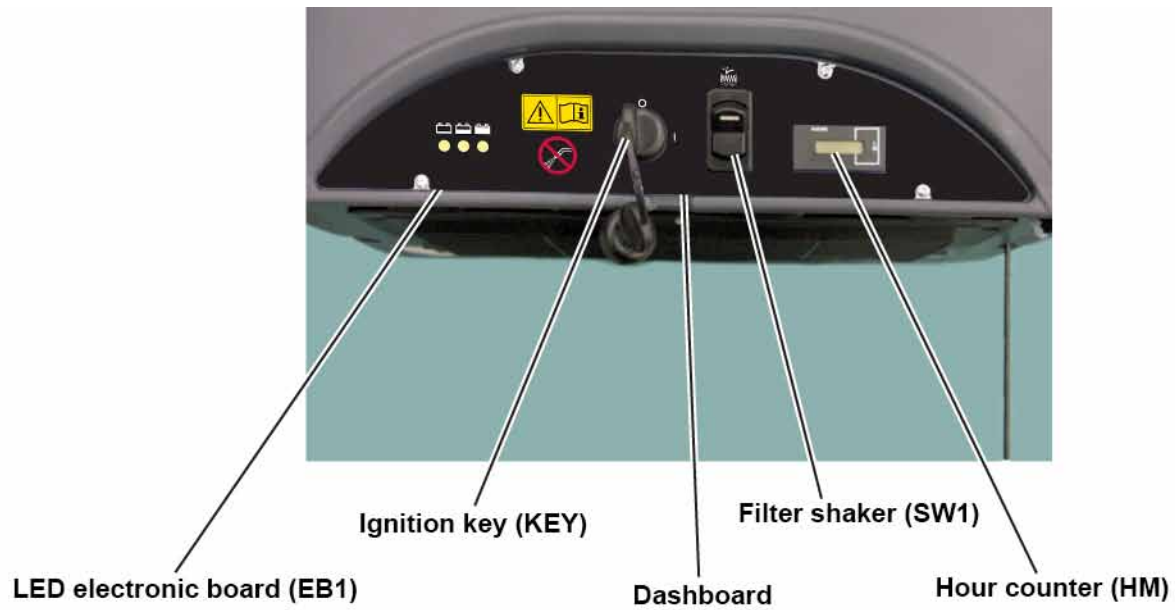

Component Locations (SW900 B) (Continues)

- Wiring harnesses
- Main motor (M0)
- Batteries (BAT)
- Battery connector
- Main motor relay (K0)
- 5A fuse, electrical filter shaker (F1)
- 125A fuse, battery (F0)
- Reduction unit
- Filter shaker relay (K1)

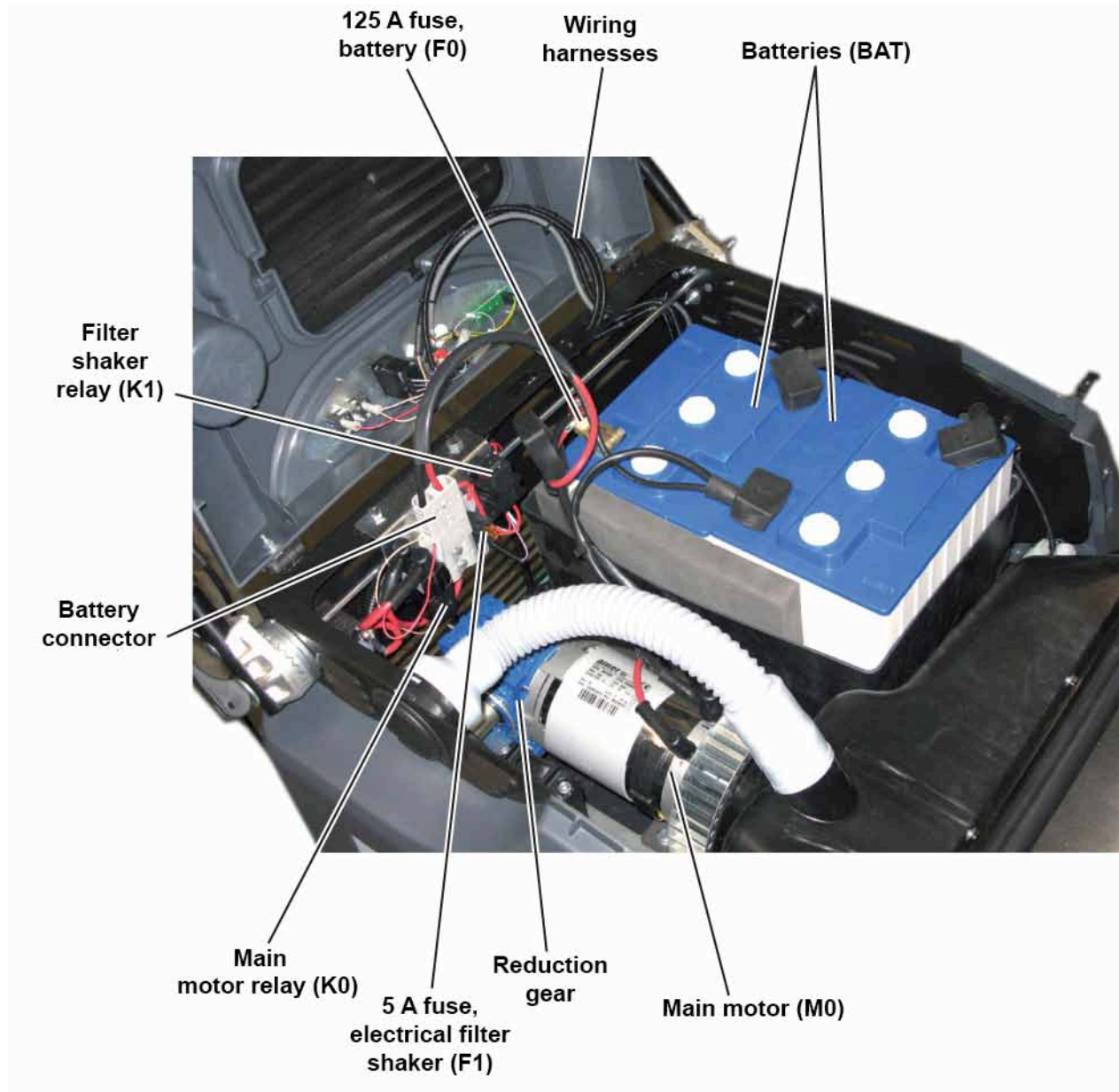

Component Locations (SW900 B) (Continues)

- Battery charger (CH)
- Hopper position microswitch (SW0)
- 30A fuse, battery charge (F2)
- 70A circuit breaker, main motor (FA)
- 5A circuit breaker, right side broom motor (FB)
- 5A circuit breaker, left side broom motor (FC)

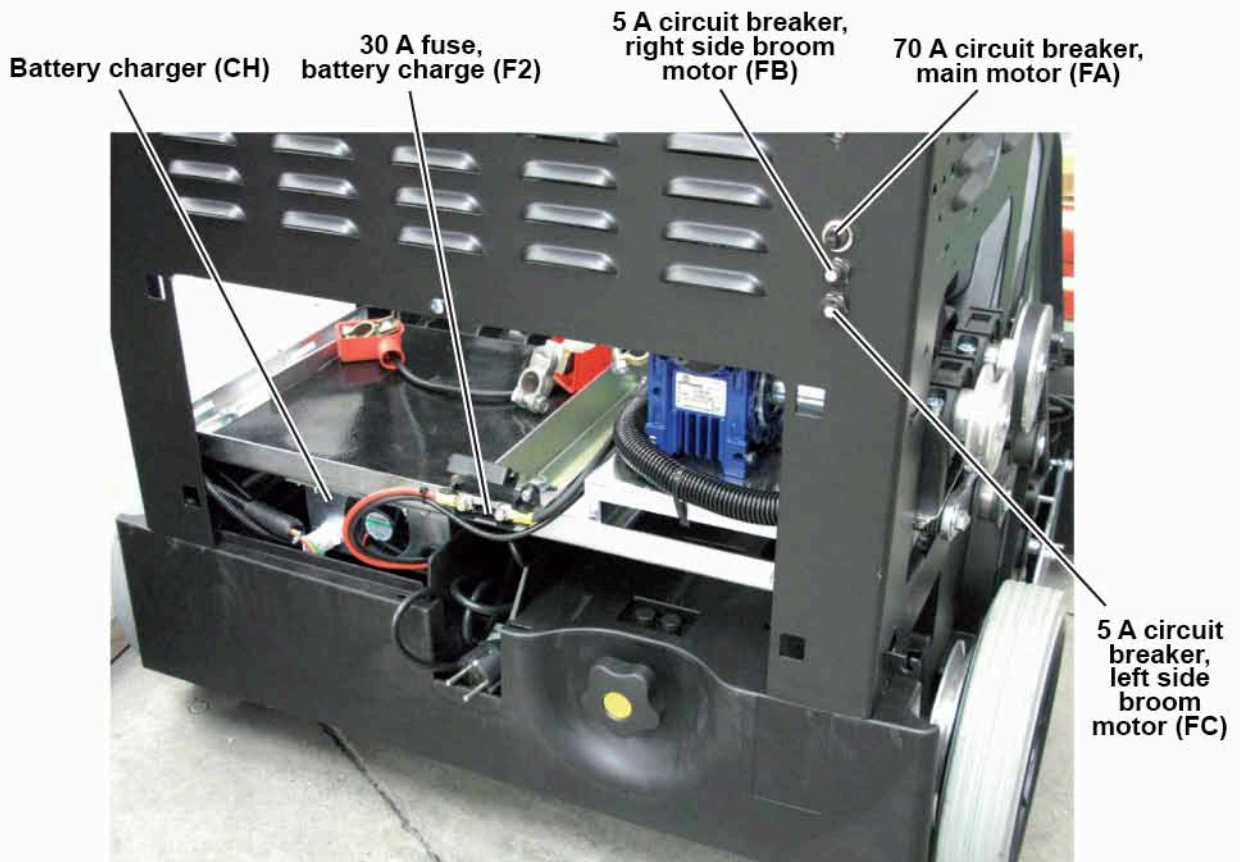

Hopper position microswitch (SW0)

Component Locations (SW900 P)

- Dashboard
- Ignition key (KEY)
- Filter shaker (SW1)
- Hour counter (HM)

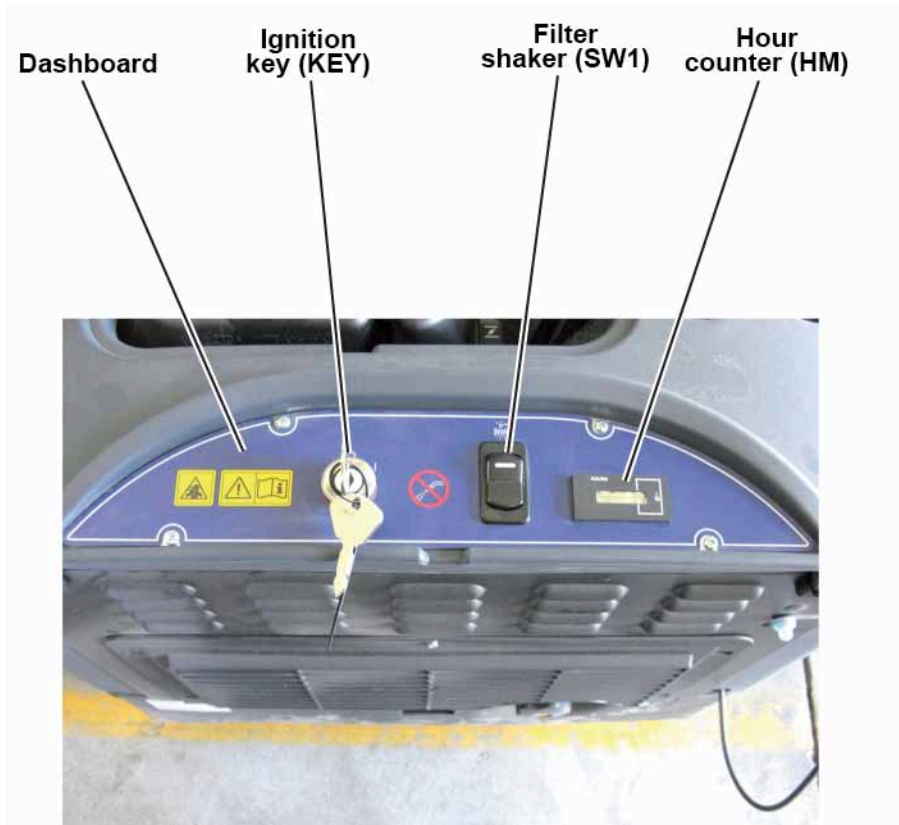

Component Locations (SW900 P) (Continues)

- Wiring harnesses
- Dynamotor (G)
- Filter shaker relay (K1)
- Electrical filter shaker (F1) fuse (5A)
- Dynamotor (FA) fuse (20A)
- Reduction unit

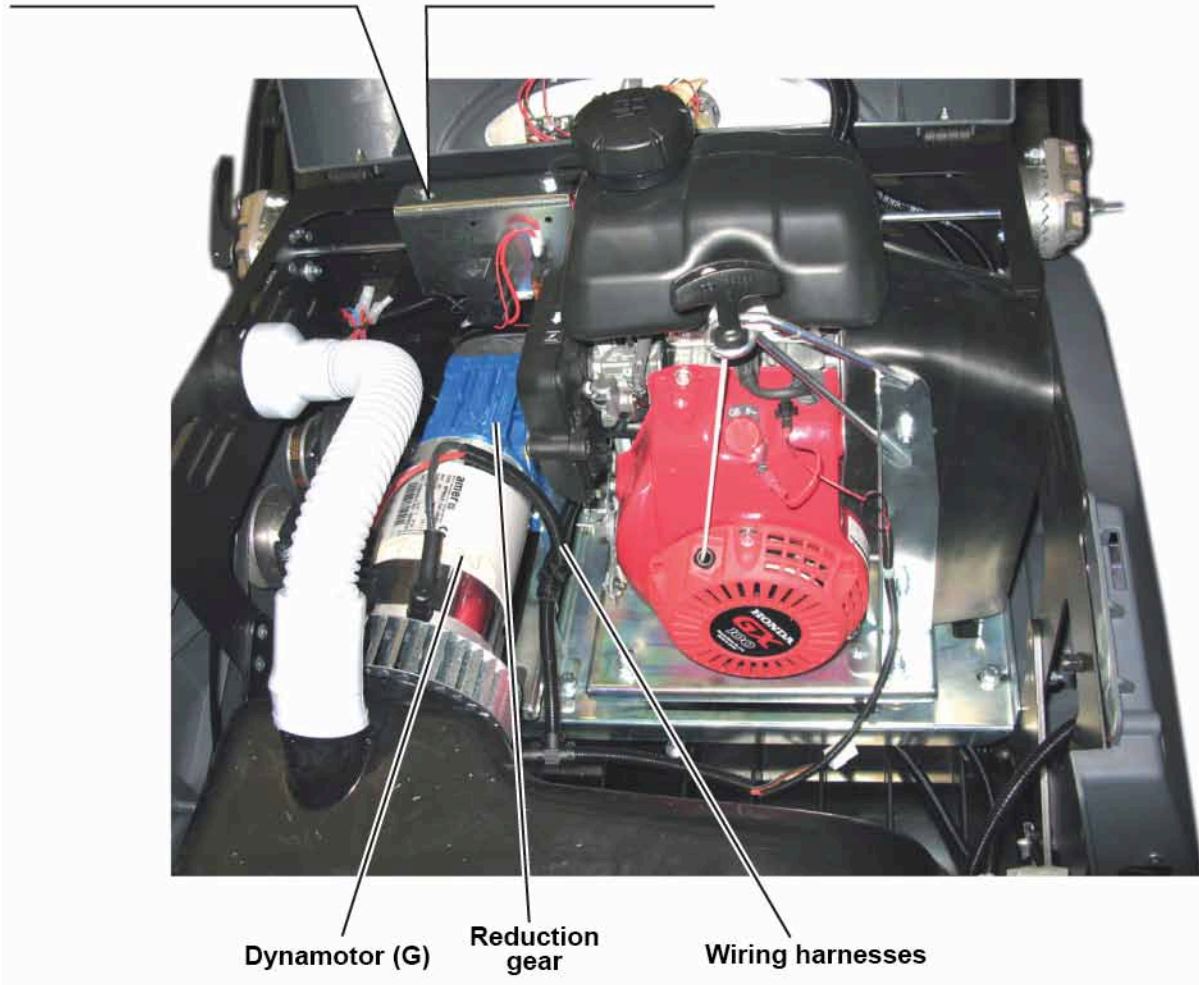
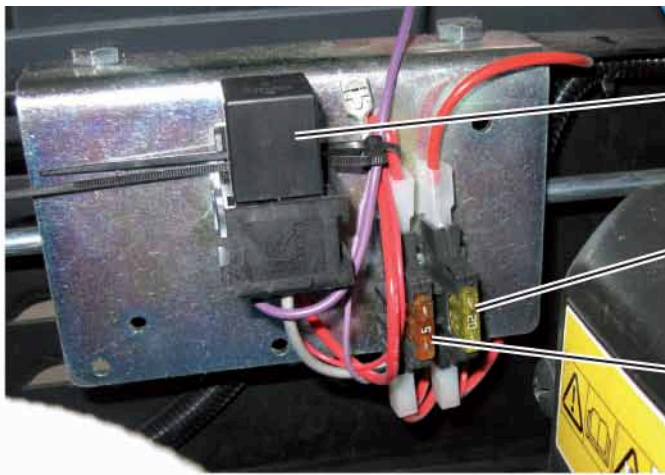

Component Locations (SW900 P) (Continues)

- Hopper position microswitch (SW0)
- Right side broom motor (FB) circuit breaker (5A)
- Left side broom motor (FC) circuit breaker (5A)



Hopper position microswitch (SW0)

Maintenance and Adjustments

Charging the batteries (SW900 B)



Caution! Charge the batteries when the yellow (A) or red (B) LED turns on, or at the end of each working cycle. Keeping the batteries charged make their life last longer.



Warning! Pay careful attention when charging lead batteries (WET) as there may be battery fluid leakages. The battery fluid is corrosive. If it comes in contact with skin or eyes, rinse thoroughly with water and consult a physician.



Warning! When the batteries are discharged, charge them as soon as possible, as that condition makes their life shorter.

1. Drive the machine on a level floor and ensure that it cannot move.
2. Turn the ignition key to “0”.



Warning! If the machine is equipped with lead (WET) batteries, battery charging produces highly explosive hydrogen gas. Charge the batteries in well-ventilated areas and away from naked flames. Do not smoke while charging the batteries. While charging the batteries always keep the hood open.

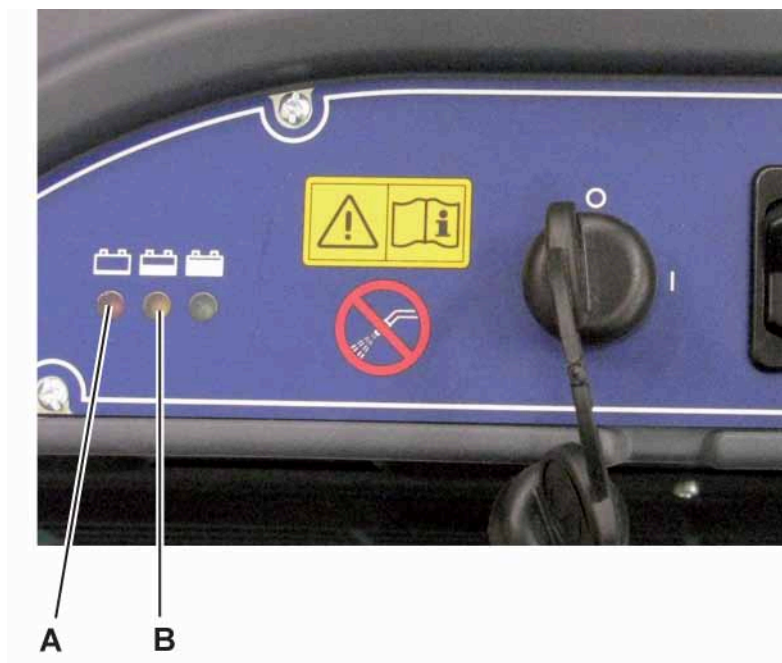

Charging the batteries (SW900 B) (Continues)

3. Remove from the housing (C) the electrical cable (D) of the electronic battery charger, then connect it to the electrical mains.



Warning! *The mains voltage and frequency must match the electronic battery charger values shown on the machine serial number plate.*



Note: *When the electronic battery charger is connected to the electrical mains, all machine functions are automatically disabled.*

4. When the green LED (E) turns on, the batteries are charged.
For further information about the battery charger operation, see the Battery Charger Manual.
5. Disconnect the electronic battery charger electrical cable (D) from the electrical mains, then place it in the housing (C).
6. Now the machine is ready to be used.

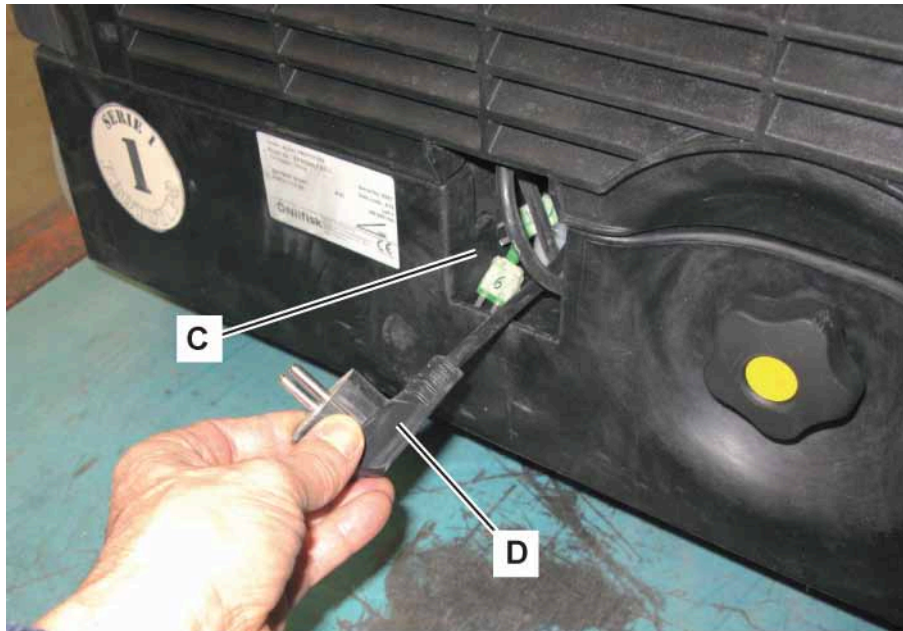

Fuse Check/Replacement/Reset (SW900 B)

1. Drive the machine on a level floor and ensure that it cannot move.
2. Turn the ignition key to “0”.

Fuse Check/Reset

3. Check one of the following fuses for deactivation:
 - (A): 70A fuse (FA), main motor
 - (B): 5A fuse (FB), right side broom motor
 - (C): 5A fuse (FC), left side broom motor
4. Reset any deactivated fuse, when the component that caused deactivation has fully cooled down.

Various Fuse Check/Replacement

5. Remove the hopper by using its transport handle and wheels.
6. Disengage the front fastener and open the battery compartment hood.
7. Disconnect the battery connector.
8. Remove the rear grid after removing the upper mounting screw and disengaging the fasteners.
9. Disengage and open the cover (I), then check the fuse:
 - (J): 30A fuse (F2), battery charger
 - If necessary, remove the nuts (D) and replace the fuse (J). Screw down and tighten the nuts.

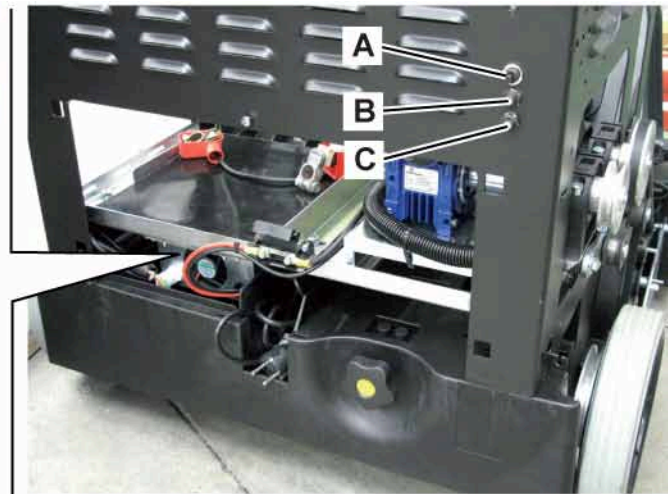
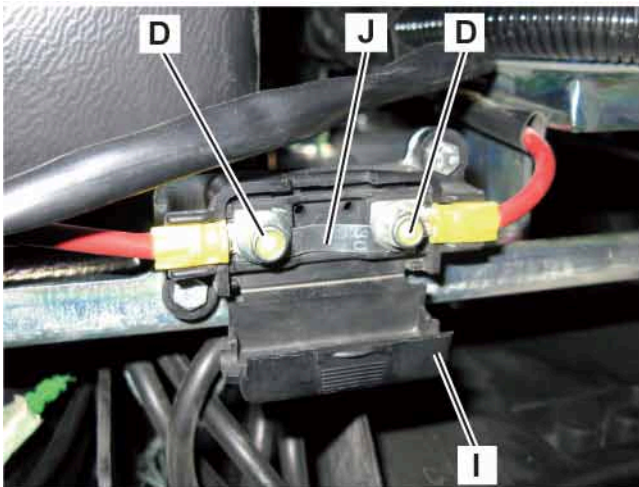

Fuse Check/Replacement/Reset (SW900 B) (Continues)

10. Check/replace the fuse:

- (E): 5A lamellar fuse (F1), electrical filter shaker

11. Check/replace the fuse:

- (F): 125A fuse (F0), battery
When reinstalling the fuse (F), engage its flange (G) on the electrical cable terminals (H), as shown in the figure.

Reassembly

12. Install the rear grid by engaging the fasteners and then tighten the upper mounting screw.
13. Connect the battery connector.
14. Close the battery compartment hood and engage the front fastener.
15. Install the hopper by using its transport handle and wheels.

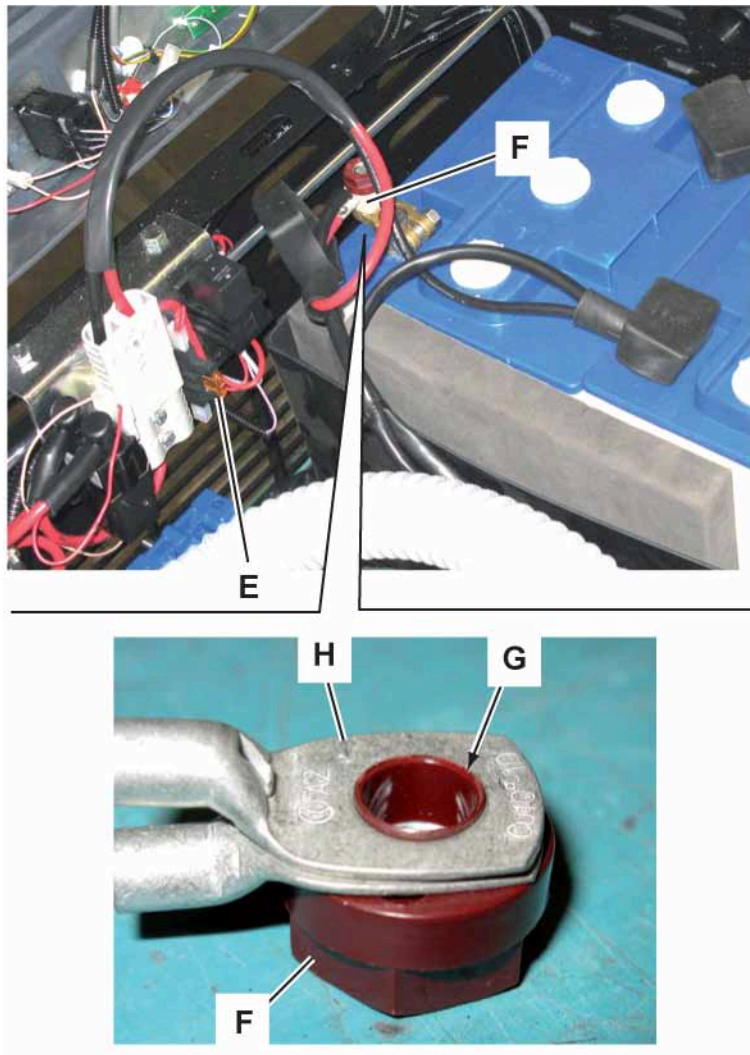

Fuse Check/Replacement/Reset (SW900 P)

1. Drive the machine on a level floor and ensure that it cannot move.
2. Turn the ignition key to “0”.

Fuse check/reset

3. Check one of the following fuses for deactivation:
 - (A): 5A fuse (FB), right side broom motor
 - (B): 5A fuse (FC), left side broom motor
4. Reset any deactivated fuse, when the component that caused deactivation has fully cooled down.



B A

Lamellar Fuse Check/Replacement

5. Remove the hopper by using its transport handle and wheels.
6. Disengage the front fastener and open the engine compartment hood.
7. On the right side of the engine (C), check/replace the fuses:
 - (D): 20A fuse (F0), main
 - (E): 5A fuse (F1), electrical filter shaker

Reassembly

8. Close the engine compartment hood and engage the front fastener.
9. Install the hopper by using its transport handle and wheels.

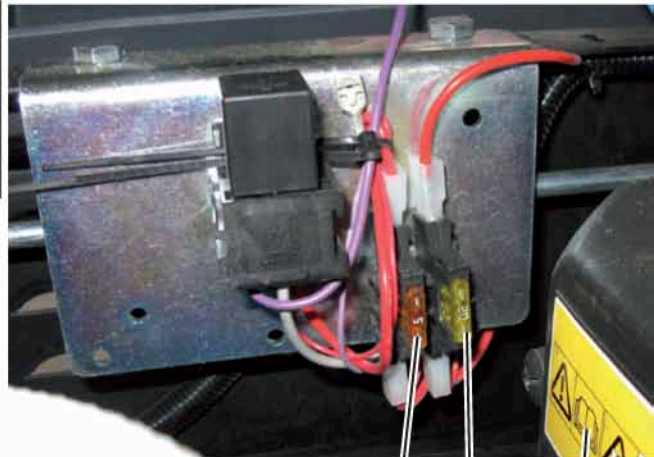

E D C

Troubleshooting (SW900 B)

Trouble	Possible causes	Remedy
The main motor does not start	The battery connector is disconnected	Connect
	The batteries are discharged	Charge
	The hopper is not in the correct position	Adjust Check the operation of the microswitch
	The upper hood is open	Close it properly Check the operation of the microswitch
	The circuit breaker (FA) is open	Press the push-button on the fuse, if the trouble persists remove the overload cause
The right/left broom motor does not run	The lever is not activated correctly	Use the lever up to the end-of-stroke Check the operation of the microswitch
	The circuit breaker (FB) or (FC) is open	Press the push-button on the fuse, if the trouble persists remove the overload cause

Removal and Installation

Battery Installation and Battery Type Setting (WET or GEL) (SW900 B)



Warning! The electric components of the machine can be seriously damaged if the batteries are either improperly installed or connected. The batteries must be installed by qualified personnel only. According to the type of batteries (WET or GEL-AGM), set the machine battery charger. Check the batteries for damage before installation. Disconnect the battery connector and the battery charger plug. Handle the batteries with great care. Install the battery terminal protection caps supplied with the machine.



Warning! Do not tilt the lead batteries (WET) to prevent the highly corrosive acid from leaking out of the batteries. Do not connect, not even accidentally, the battery positive and negative terminals by using tools, keys, etc. This could cause dangerous short-circuits.

The machine requires one 12V battery, or two 6V batteries connected according to the diagram below. The machine can be supplied in one of the following configurations:

- WET or GEL batteries already installed on the machine
- Without batteries



Note: The machine is supplied with the battery charger set for using generic GEL-AGM batteries.

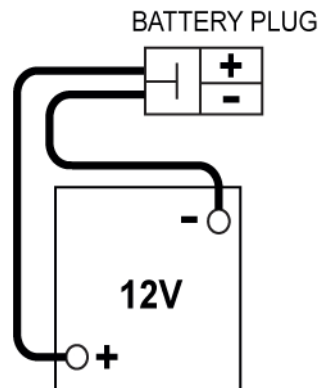
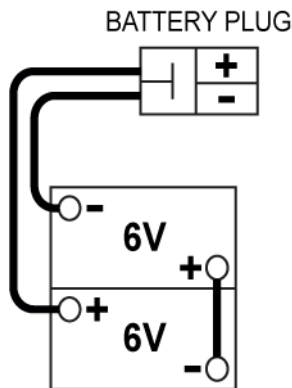

Battery Installation and Battery Type Setting (WET or GEL) (SW900 B) (Continues)

Battery Removal

1. Drive the machine on a level floor and ensure that it cannot move.
2. Turn the ignition key to “0”.
3. Remove the hopper by using its transport handle and wheels.
4. Disengage the front fastener and open the battery compartment hood.
5. Disconnect the battery connector.
6. Disengage the guards (A) from the battery terminals.
7. Disconnect the battery terminals.
8. Carefully remove the batteries (B).

Battery installation

1. Install on the machine the type of batteries which is compatible with the setting of the machine; for checking the setting of the machine or to change it, refer to the procedure described below.
2. Route and install the battery cables, then carefully tighten the nut on each battery terminal.
3. Engage the guards (A) on the battery terminals.
4. Connect the battery connector.
5. Close the battery compartment hood and engage the front fastener.
6. Install the hopper on the machine, by using its transport handle and wheels.

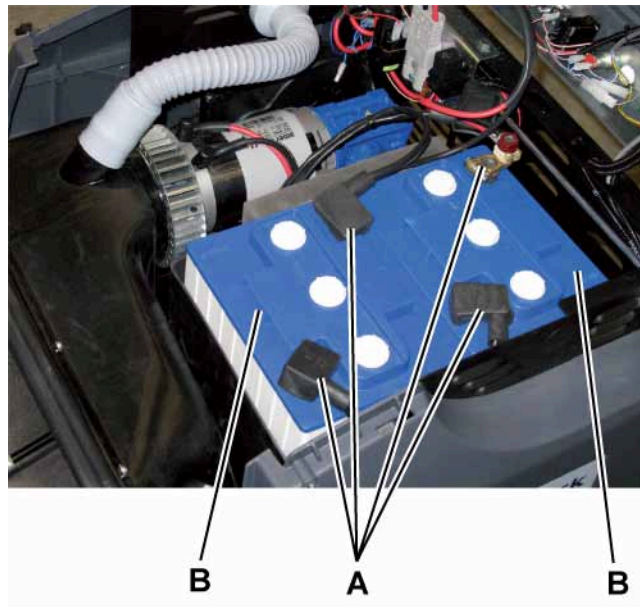

Machine Check/Setting

1. Drive the machine on a level floor and ensure that it cannot move.
2. Turn the ignition key to “0”.
3. Remove the hopper by using its transport handle and wheels.
4. Disengage the front fastener and open the battery compartment hood.
5. Disconnect the battery connector.
6. Check the battery cables for insulation.
7. Remove the battery charger cable (A) from the housing; connect it temporarily to the electrical mains and, during the connection, check the number and color of the LED flashings (B), then compare them with the indications in the following table, to determine the battery setting of the machine.

Type of battery set on the machine	Flashes
EXIDE™	Two flashes of the yellow LED
OPTIMA™	Two flashes of the green and yellow LEDs together
DISCOVER™	Two flashes of the red and green LEDs together
GEL/AGM (generic)	Two flashes of the green LED
WET (all makes)	Two flashes of the red LED

8. If it is necessary to install batteries which are different from the machine setting, it is possible to change the machine settings according to the following procedure.
9. If equipped, remove the batteries from the machine and also remove the battery case.



A



B

Machine Check/Setting (Continues)

- 10. In the battery compartment, lift the rubber mat (C).
- 11. Lift the battery charger plate (D).
- 12. Carefully set the switches (E, F, G) as shown in the following table to set machine according to the type of batteries to be installed.

Type of battery set on the machine	E switch	F switch	G switch
EXIDE™	OFF	OFF	OFF
OPTIMA™	OFF	ON	OFF
DISCOVER™	ON	OFF	OFF
GEL/AGM (generic)	ON	ON	OFF
WET (all makes)	Any	Any	ON

Set the switch (H) as shown below:

- For batteries having capacity of 150Ah or higher (discharge in 5 hours) leave the default setting to OFF (nominal charge current 25A).
- For batteries having capacity lower than 150Ah (discharge in 5 hours) set H switch to ON (nominal charge current 15A).

- 13. Repeat steps 6. and 7. to check that the machine has been set correctly.
- 14. Reinstall the plate (D) and the floor mat (C).
- 15. Install the battery case.
- 16. Install the batteries.

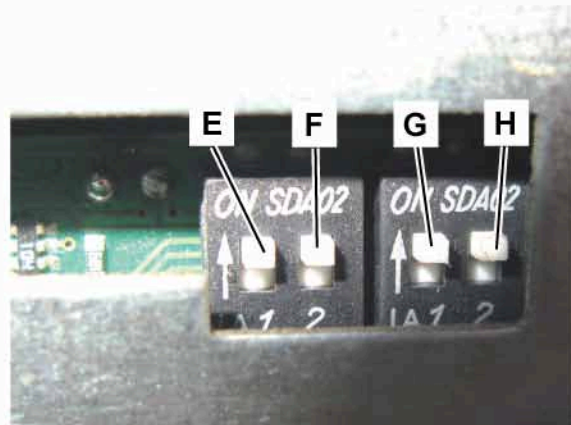
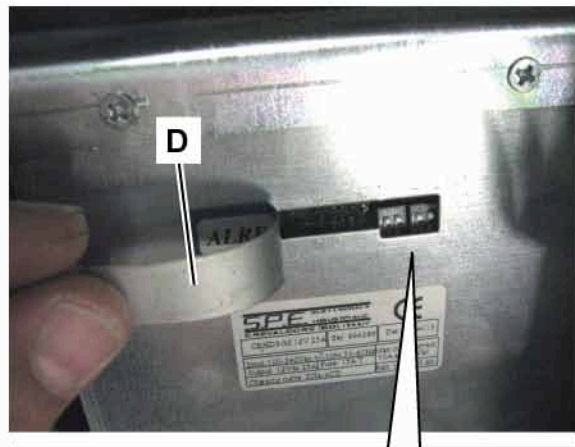

Main motor amperage check (SW900 B)



Warning! This procedure must be performed by qualified personnel only.

1. Drive the machine on a level floor and ensure that it cannot move.
2. Turn the ignition key to “0”.
3. Remove the hopper by using its transport handle and wheels.
4. Check that the side brooms are lifted.
5. Disengage the front fastener and open the battery compartment hood.
6. Remove the screws (A) and the right side panel (B) from the machine.
7. Turn the tensioner (C) in the direction shown by the arrow and disengage the belt (D) from the pulley (E).
8. Turn the tensioner (F) in the direction shown by the arrow and disengage the belt (G) from the pulley (H).
9. Apply amp clamps on a cable (I) of the main motor (J).
10. Carefully operate and keep operated, the hopper position microswitch (K) (to simulate the presence of the hopper).
11. Turn the ignition key to “T” thus turning on the main motor; check that the amperage of the motor (J) is between 30 and 35A at 24V.
12. Turn the ignition key to “0”.
13. Remove the amp clamp.

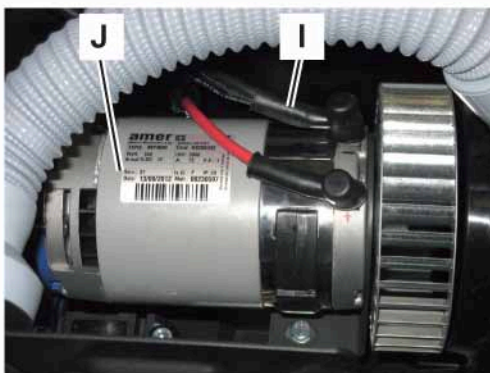
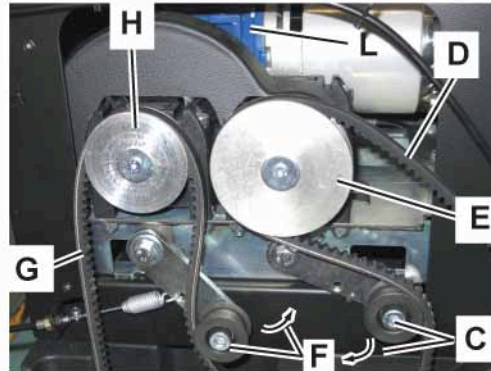

Main motor amperage check (SW900 B) (Continues)

14. If the amperage is higher, perform the following procedures to detect and correct it:
- Check that there are no obstacles to the rotation of the pulleys (E) and (H) and the reduction unit (L).
 - Check the main motor carbon brushes (see the procedure in the relevant paragraph).
 - If necessary, disassemble the main motor (see the procedure in the relevant paragraph), and check the condition of all its components.

If the above-mentioned procedures do not lead to a correct amperage, the main motor must be replaced (see the procedure in the relevant paragraph).

Reassembly

15. Release the hopper position microswitch (K) from the forced operation, and check that the microswitch operates properly.
16. Turn the tensioner (F) in the direction shown by the arrow and engage the belt (G) to the pulley (H) and to the tensioner (F); check the proper operation of the tensioner (F).
17. Turn the tensioner (C) in the direction shown by the arrow and engage the belt (D) to the pulley (E) and to the tensioner (C); check the proper operation of the tensioner (C).
18. Perform steps 3, 5, and 6, in the reverse order.

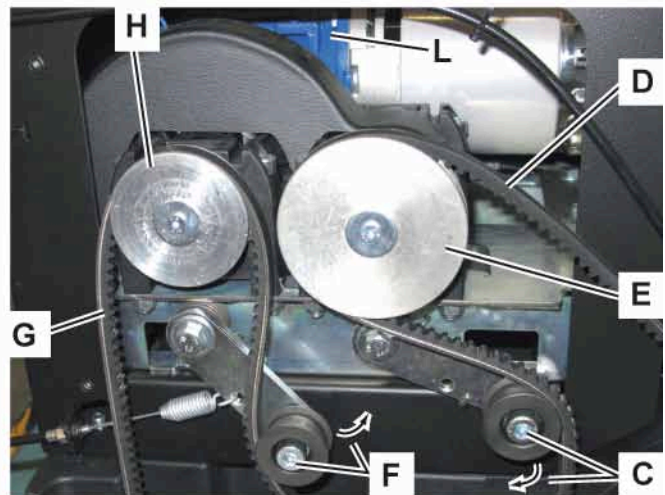
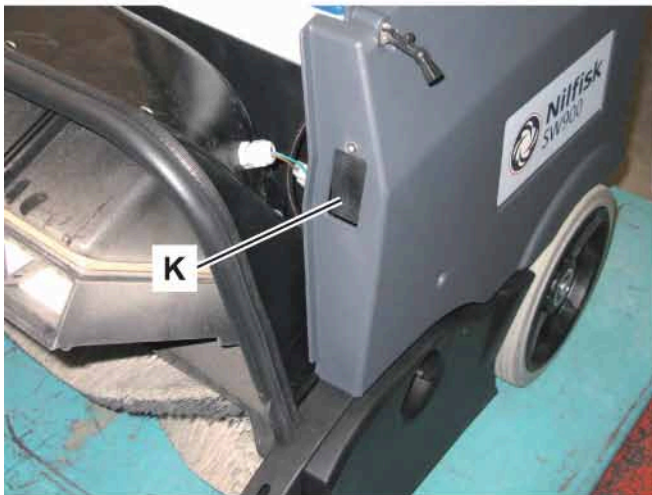

P200281

Dynamotor Voltage Check (SW900 P)



Warning! *This procedure must be performed by qualified personnel only.*

1. Drive the machine on a level floor and ensure that it cannot move.
2. Turn the ignition key to “0”.
3. Remove the hopper by using its transport handle and wheels.
4. Carefully operate and keep operated, the hopper position microswitch (to simulate the presence of the hopper).
5. Check that the main and side brooms(s) are lifted.
6. Turn the ignition key to “I” and start the petrol engine (as shown in the User Manual); wait at least 5 minutes that the engine reaches the target speed.
7. Disengage the front fastener and open the engine compartment hood.
8. Move aside the guards (A) of the terminals (B) and (C) of the dynamotor (D).
9. Apply the detectors (E) and (F) of the tester on the terminals (B) and (C) and measure the voltage produced by the dynamotor, which must be between the 12V and 14V. Stop the petrol engine (as shown in the User Manual). Turn the ignition key to “0”.

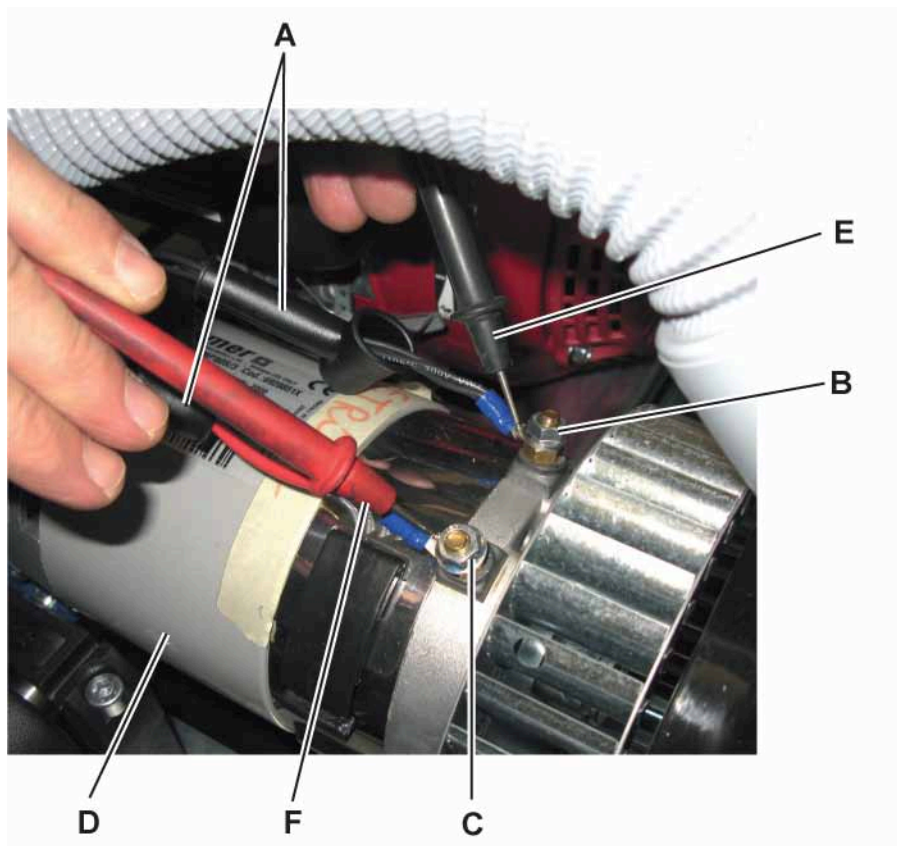

Dynamotor Voltage Check (SW900 P) (Continues)

If the voltage is lower than the specified value, perform the following procedures to detect the cause and correct it:

- Check that the drive belt between the engine and reduction unit is properly tensioned (see the procedure in the relevant paragraph) and that the pulleys are efficient and not loose.
- Check that the reduction unit is correctly closed.
- Check the dynamotor carbon brushes (see the procedure in the relevant paragraph).
- If necessary, disassemble the dynamotor (see the procedure in the relevant paragraph), and check the condition of all its components.

If the above-mentioned procedures do not lead to a correct voltage, the dynamotor must be replaced (see the procedure in the relevant paragraph).

Reassembly

10. Close the engine compartment hood and engage the front fastener.
11. Release the hopper position microswitch from the forced operation, and check that the microswitch operates properly.
12. Install the hopper by using its transport handle and wheels.

Main motor carbon brush replacement (SW900 B)

Disassembly

1. Drive the machine on a level floor and ensure that it cannot move.
2. Turn the ignition key to “0”.
3. Remove the hopper by using its transport handle and wheels.
4. Disengage the front fastener and open the battery compartment hood.
5. Disconnect the battery connector.
6. Remove the batteries and their container (see the procedure in the relevant paragraph).
7. Remove the screws (A) and the right side panel (B) from the machine; then remove also the left side panel.
8. On the main motor, release the fastener (C) and remove the protection band (D) of the carbon brushes.
9. Remove the fastening screws (E) of the electrical connections of the four carbon brushes (F).
10. Remove the four carbon brushes (F) from their housings, by disengaging them from the retaining springs (G).
11. Check the two carbon brushes (F) for wear. Replace the carbon brushes when: the contact with the motor armature is insufficient, the carbon brushes are worn, the carbon brush contact surface is not integral, the thrust spring is broken, etc. If the length of the carbon brushes is insufficient, these must be replaced. In this cases, replace all motor carbon brushes.

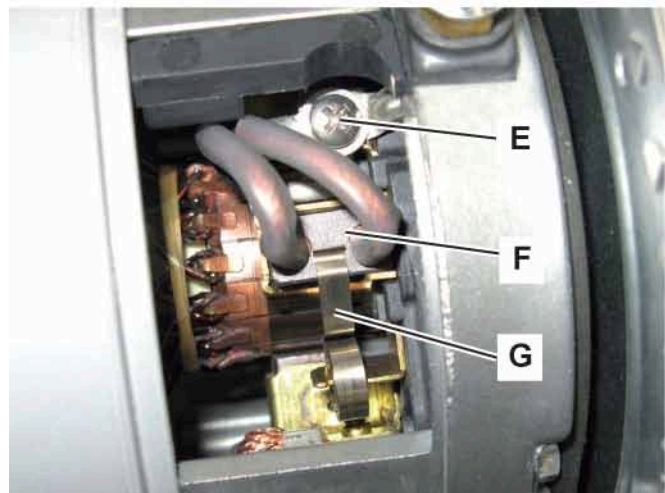
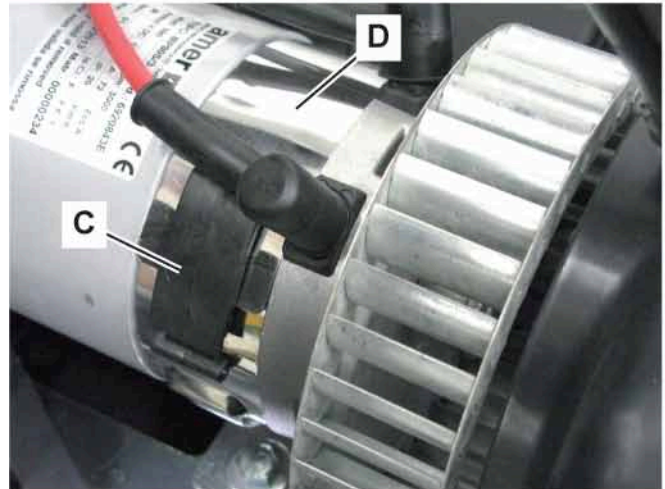

Assembly

12. Assemble the components in the reverse order of disassembly.

Dynamotor Carbon Brush Replacement (SW900 P)

Disassembly

1. Drive the machine on a level floor and ensure that it cannot move.
2. Turn the ignition key to “0”.
3. Remove the hopper by using its transport handle and wheels.
4. Disengage the front fastener and open the engine compartment hood.
5. Remove the screws (A) and the right side panel (B) from the machine; then remove also the left side panel.
6. On the dynamotor, release the fastener (C) and remove the protection band (D) of the carbon brushes.
7. Remove the fastening screws (E) of the electrical connections of the four carbon brushes (F).
8. Remove the four carbon brushes (F) from their housings, by disengaging them from the retaining springs (G).
9. Check the two carbon brushes (F) for wear. Replace the carbon brushes when: the contact with the dynamotor armature is insufficient, the carbon brushes are worn, the carbon brush contact surface is not integral, the thrust spring is broken, etc. If the length of the carbon brushes is insufficient, these must be replaced. In this cases, replace all motor carbon brushes.

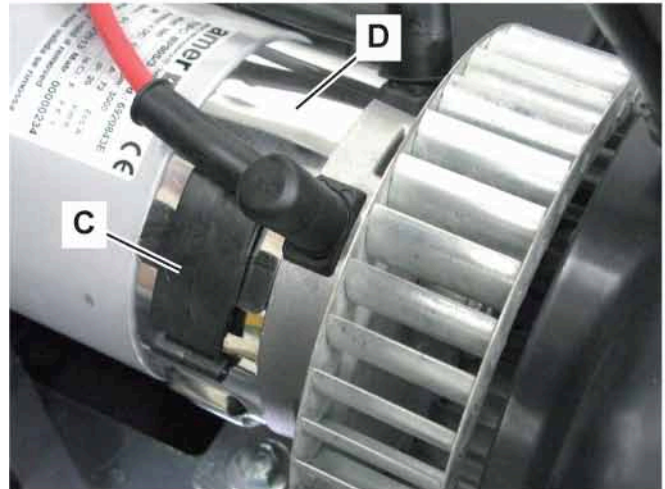

Assembly

10. Assemble the components in the reverse order of disassembly.

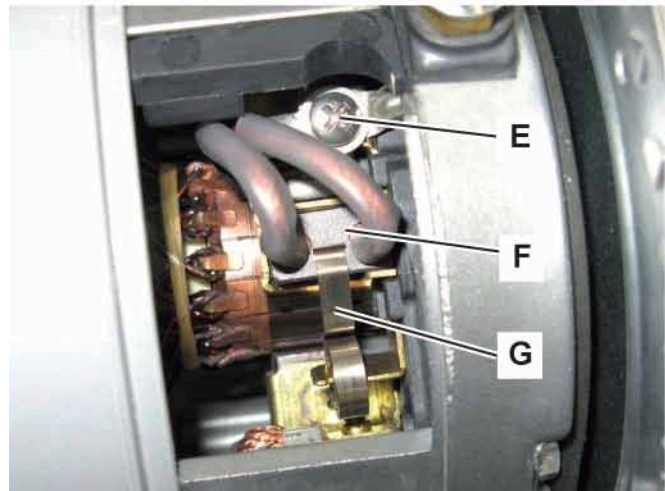

Main Motor or Fan Removal/Installation (SW900 B)

Disassembly

1. Drive the machine on a level floor and ensure that it cannot move.
2. Turn the ignition key to “0”.
3. Remove the hopper by using its transport handle and wheels.
4. Disengage the front fastener and open the battery compartment hood.
5. Remove the batteries and their container (see the procedure in the relevant paragraph).
6. Remove the screws (A) and the right side panel (B) from the machine; then remove also the left side panel.
7. Remove the rear grid (C) after removing the upper mounting screw (D) and disengaging the fasteners.
8. Turn the tensioner (E) in the direction shown by the arrow and disengage the belt (F) from the pulley (G).
9. Turn the tensioner (H) in the direction shown by the arrow and disengage the belt (I) from the pulley (J).

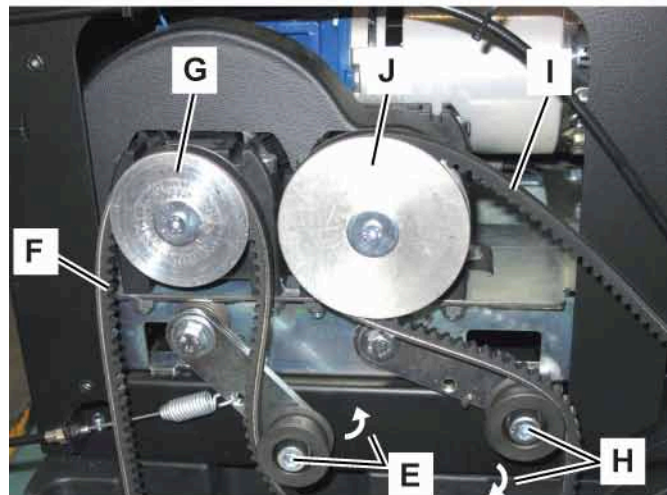
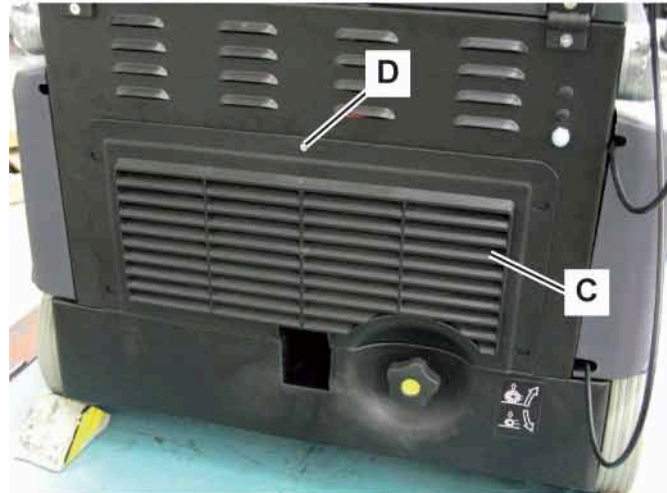

Main Motor or Fan Removal/Installation (SW900 B) (Continues)

10. On the rear side of the machine, cut the clamps (K) fastening the wiring harness (L); cut also the inner clamp (M).
11. Disengage the protection caps (N) and disconnect the electrical connections (O) of the main motor.
12. Loosen the clamp (P) and disconnect the “wet by pass” hose (Q).
13. Remove the screws (R) with nut (S).
14. On the inner side of the main motor (T), remove the screws (U).
15. Carefully remove the main motor assembly with the reduction unit (V).

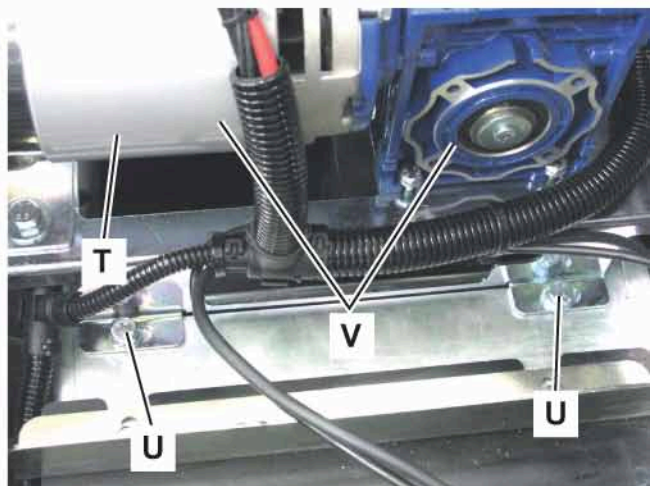
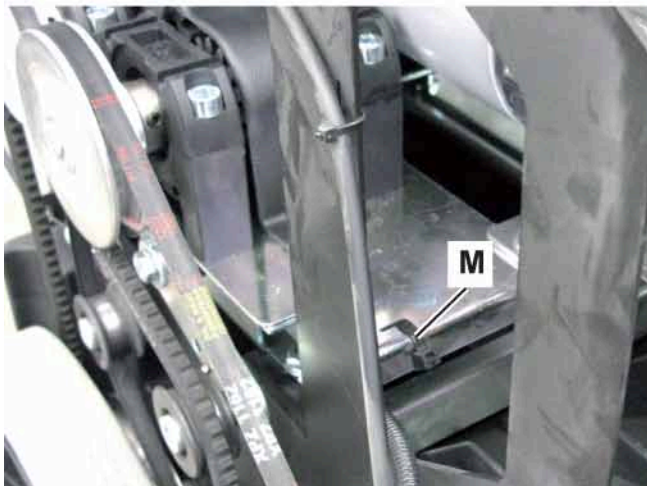
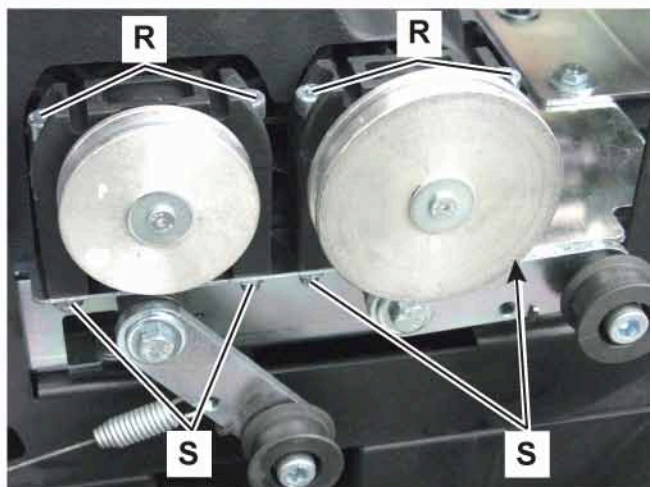
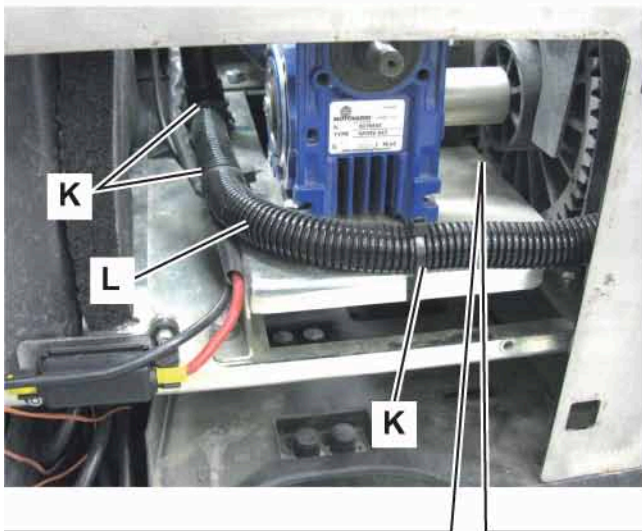
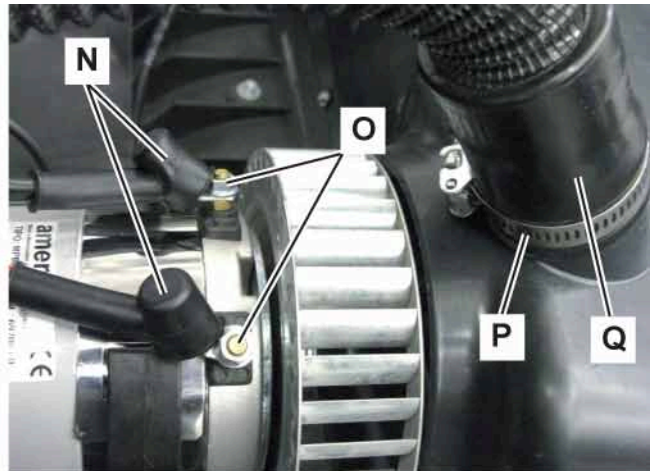

Main Motor or Fan Removal/Installation (SW900 B) (Continues)

- 16. At the workbench, remove the screws with the nut (W).
- 17. Remove the four screws (X) and disconnect the motor (Y) from the reduction unit (Z), by disengaging the shaft with key (AH); if necessary use a plastic mallet.

- 18. If necessary, remove the fan (AA) as shown below.
- 19. Remove the screw (AB) and the dowel (AC).

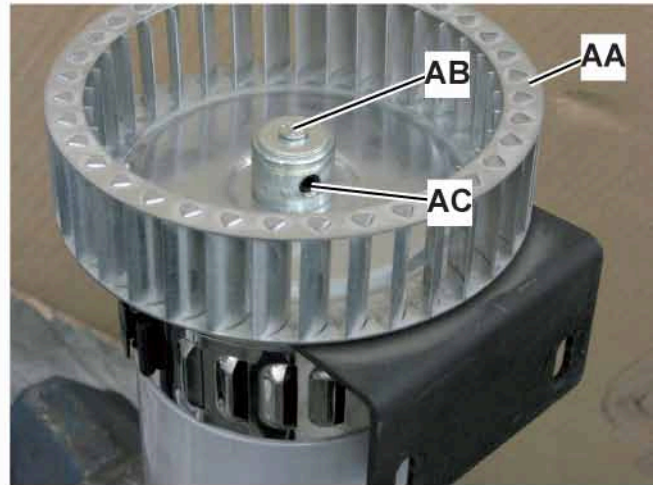
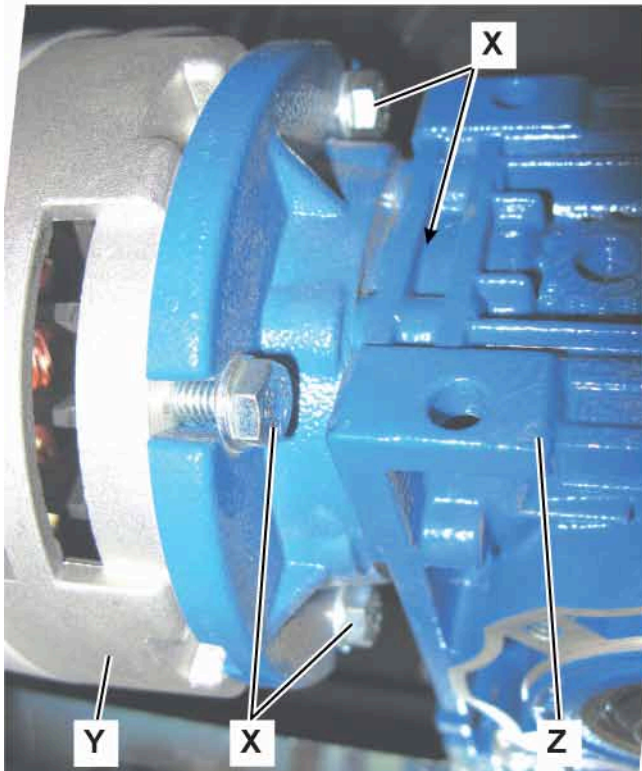
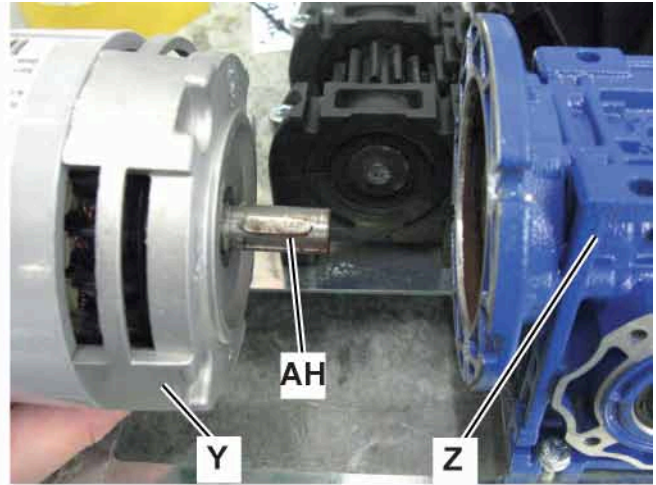
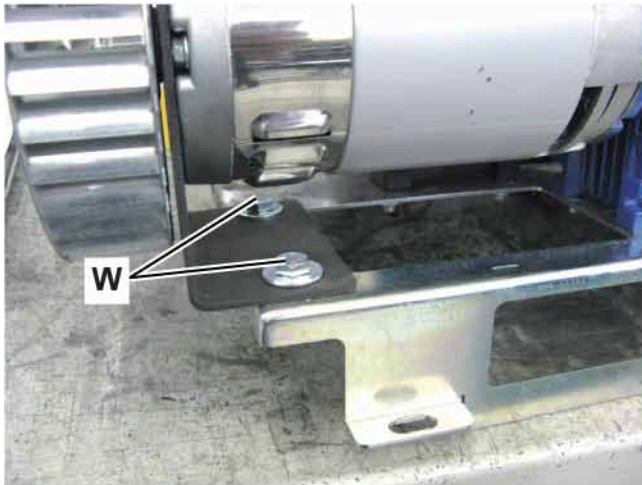

Main Motor or Fan Removal/Installation (SW900 B) (Continues)

20. With a puller applied to the head (AD) of the shaft and on the groove (AE), remove the fan (AA) from the shaft.
21. If necessary, remove the four screws (AG) and remove the flange (AF).

Assembly

22. Assemble the components in the reverse order of disassembly, and note the following:
 - Reinstall the flange (AF) with the side (AH) turned to the opposite side of the motor electrical connection terminals (AI).

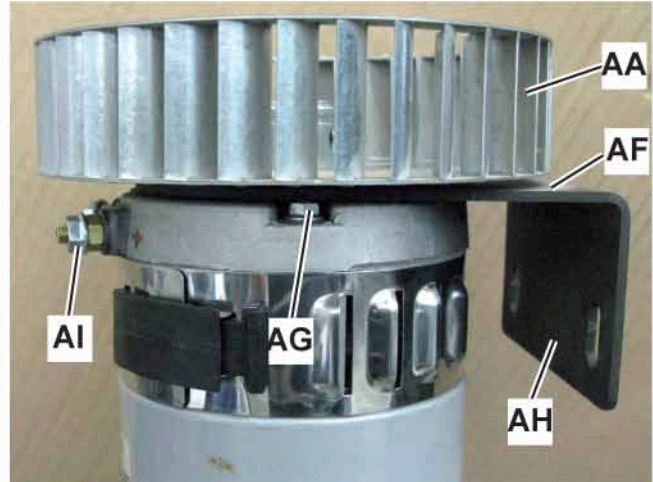
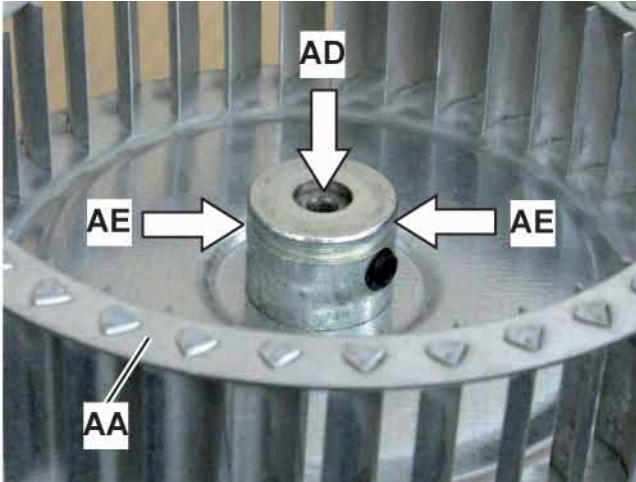

P200320

Dynamotor Removal/Installation (SW900 P)

Disassembly

1. Drive the machine on a level floor and ensure that it cannot move.
2. Turn the ignition key to “0”.
3. Remove the hopper by using its transport handle and wheels.
4. Disengage the front fastener and open the engine compartment hood.
5. Remove the screws (A) and the right side panel (B) from the machine; then remove also the left side panel.
6. Disconnect the engine belt from the reduction unit pulley (refer to the procedure for engine belt replacement in the relevant paragraph).
7. Turn the tensioner (E) in the direction shown by the arrow and disengage the belt (F) from the pulley (G).
8. Turn the tensioner (H) in the direction shown by the arrow and disengage the belt (I) from the pulley (J).

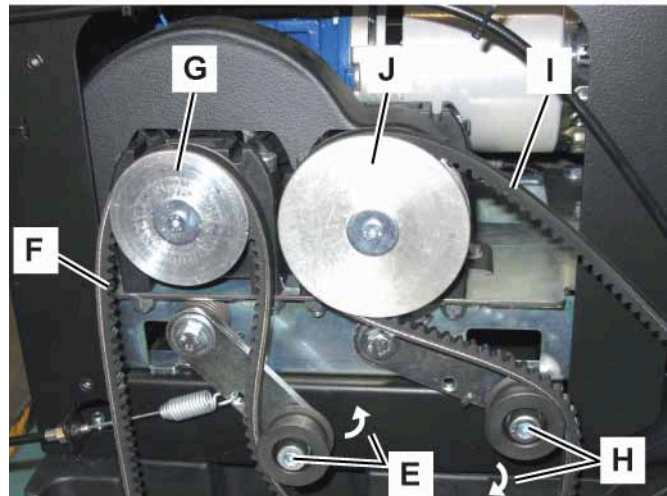

P200321

Dynamotor Removal/Installation (SW900 P) (Continues)

9. On the rear side of the machine, cut the clamps (K) fastening the wiring harness (L); cut also the inner clamp (M).
10. Disengage the protection caps (N) and disconnect the electrical connections (O) of the dynamotor.
11. Loosen the clamp (P) and disconnect the “wet by pass” hose (Q).
12. Remove the screws (R) with nut (S).
13. On the inner side of the dynamotor (T), remove the screws (U).
14. Carefully remove the dynamotor assembly with the reduction unit (V).

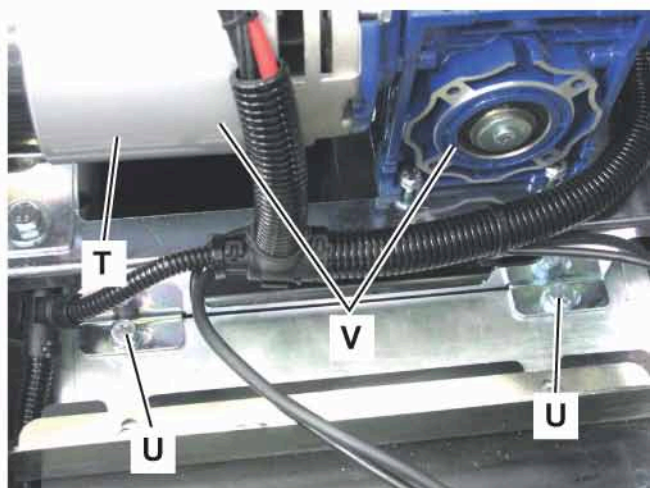
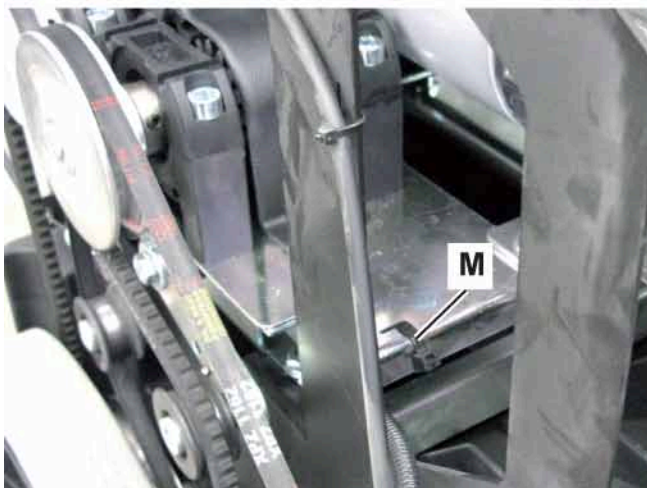
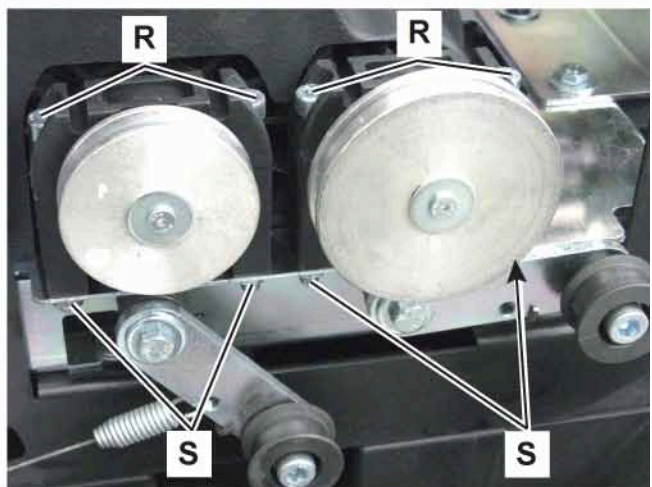
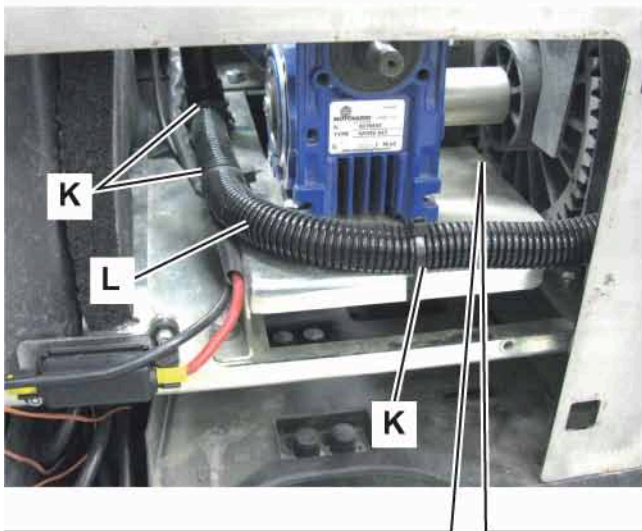
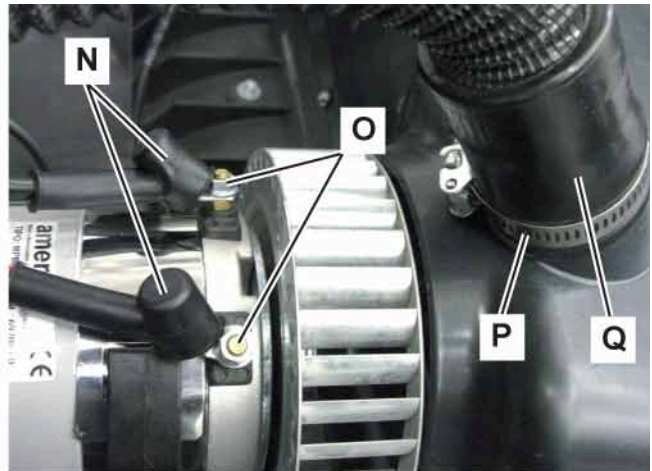

Dynamotor Removal/Installation (SW900 P) (Continues)

- 15. At the workbench, remove the screws with the nut (W).
- 16. Remove the four screws (X) and disconnect the motor (Y) from the reduction unit (Z), by disengaging the shaft with key (AH); if necessary use a plastic mallet.

- 17. If necessary, remove the fan (AA) as shown below.
- 18. Remove the screw (AB) and the dowel (AC).

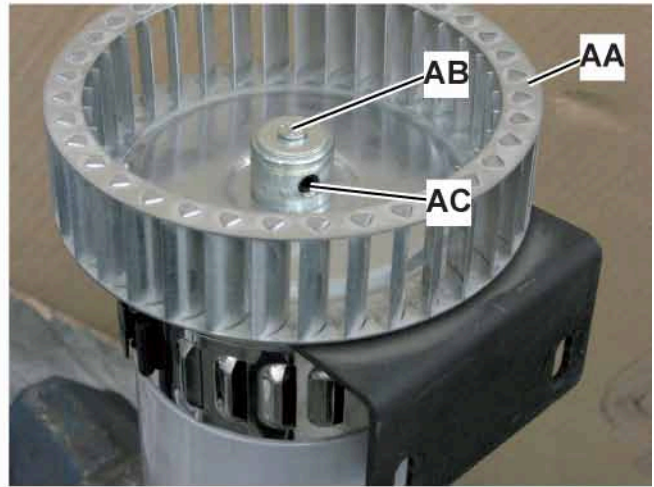
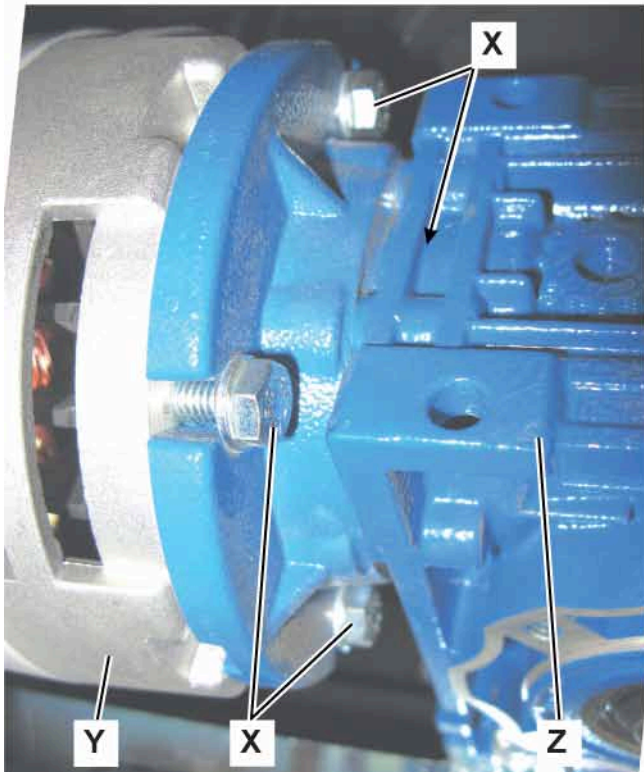
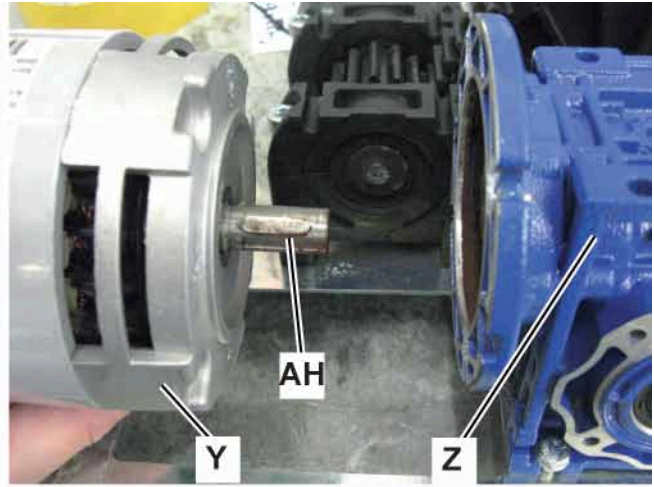
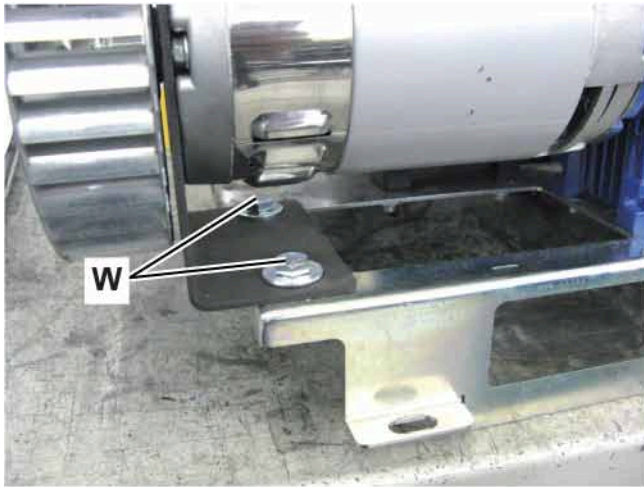

Dynamotor Removal/Installation (SW900 P) (Continues)

19. With a puller applied to the head (AD) of the shaft and on the groove (AE), remove the fan (AA) from the shaft.
20. If necessary, remove the four screws (AG) and remove the flange (AF).

Assembly

21. Assemble the components in the reverse order of disassembly, and note the following:
 - Reinstall the flange (AF) with the side (AH) turned to the opposite side of the dynamotor electrical connection terminals (AI).

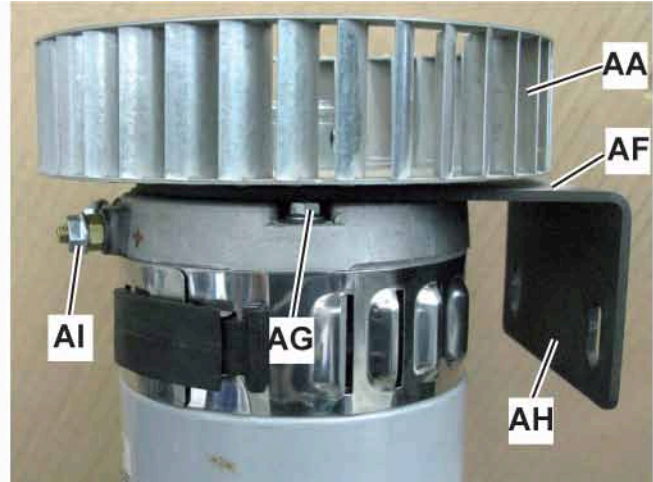
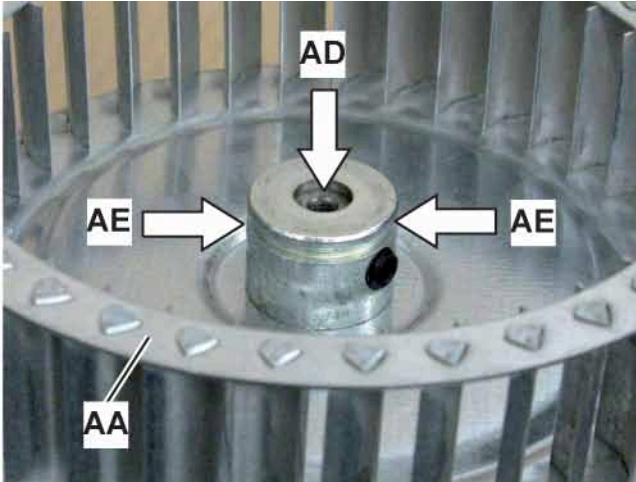

P200320

Reduction Unit Removal/Installation

Disassembly

1. Remove the main motor (Battery version) or the dynamotor (Petrol version) and separate it from the reduction unit (see the procedure in the relevant paragraph).
2. Remove the screw (A) of the reduction unit (B).
3. Remove the four screws (C).
4. Remove the reduction unit (B) by pushing it in the direction shown by the arrow (D) and by disengaging it from the shaft with key (E). If necessary use a plastic mallet.

Assembly

5. Assemble the reduction unit in the reverse order of disassembly.

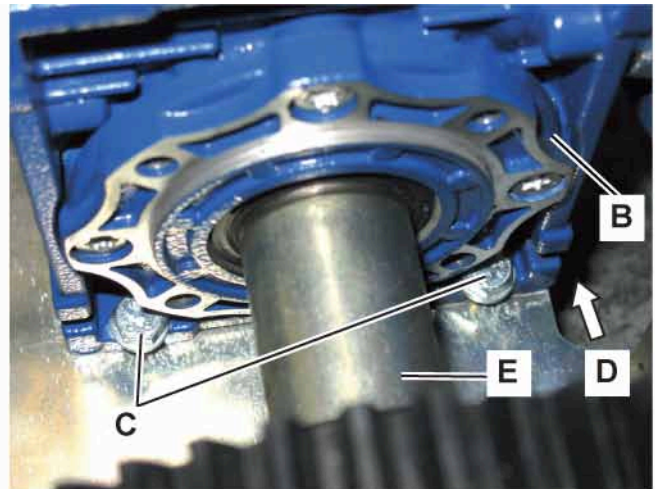
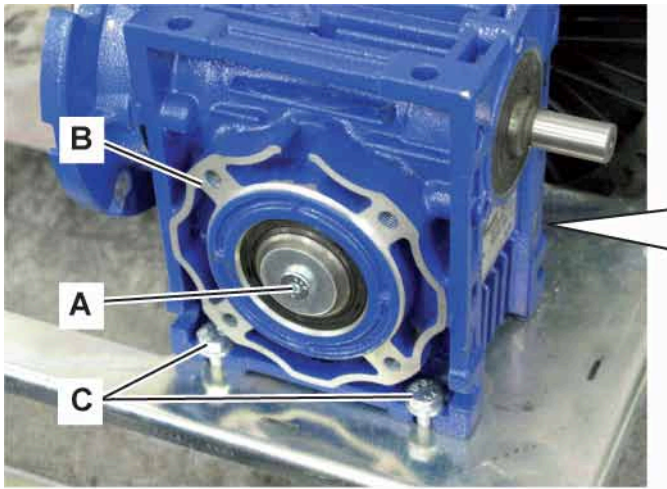

P200322

Main Broom Shaft (Small) Gear Removal/Installation

Disassembly

1. Drive the machine on a level floor and ensure that it cannot move.
2. Turn the ignition key to “0”.
3. Remove the hopper by using its transport handle and wheels.
4. Disengage the front fastener and open the battery/engine compartment hood.
5. Remove the screws (A) and the right side panel (B) from the machine.
6. Remove the rear grid (C) after removing the upper mounting screw (D) and disengaging the fasteners.
7. Turn the tensioner (E) in the direction shown by the arrow and disengage the belt (F) from the pulley (G).
8. Turn the tensioner (H) in the direction shown by the arrow and disengage the belt (I) from the pulley (J).

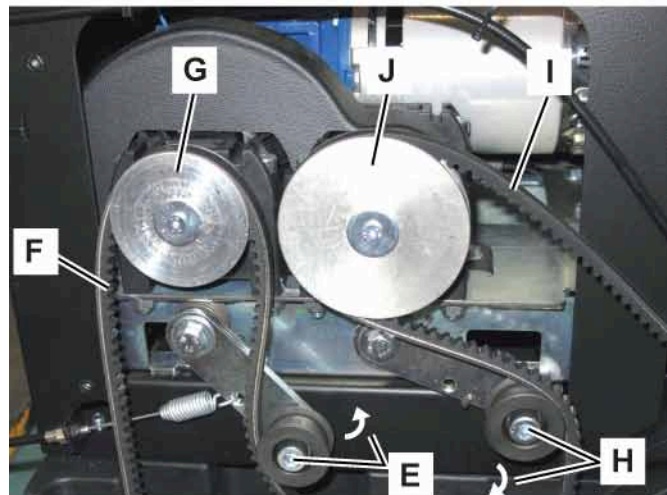
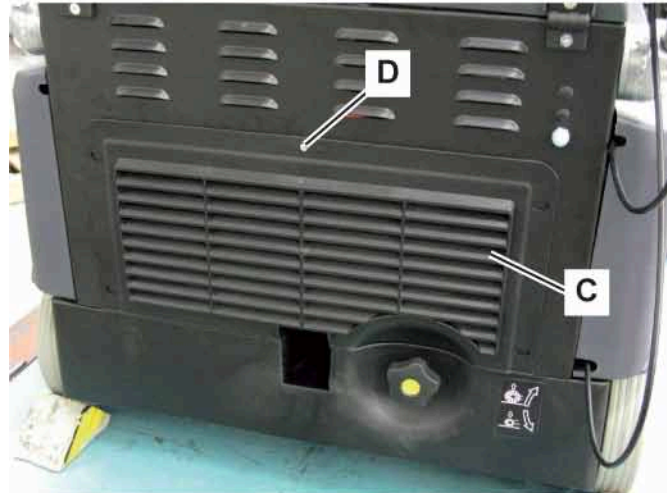

Main Broom Shaft (Small) Gear Removal/Installation (Continues)

9. Operating in the back side of the reduction unit, cut the clamp (K) fastening the wiring harness (L).
10. Remove the two screws (M) and remove the gear case (N).
11. Remove the four screws with nut (O) and the pulley assembly with gear (P).
12. At the workbench, remove the screw (Q) and the dowel (R), then remove the pulley (S).

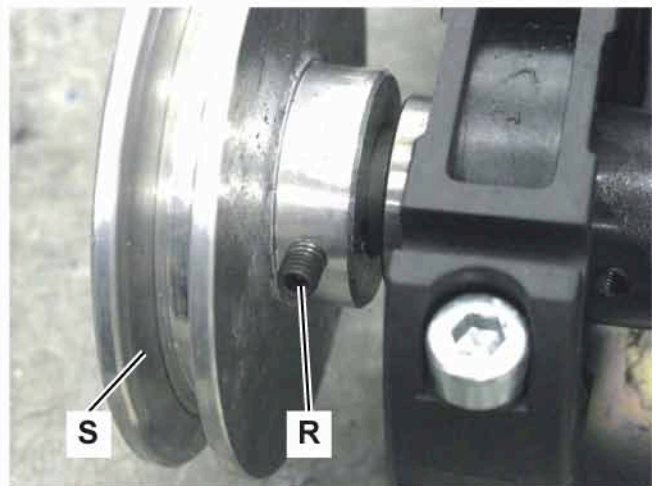
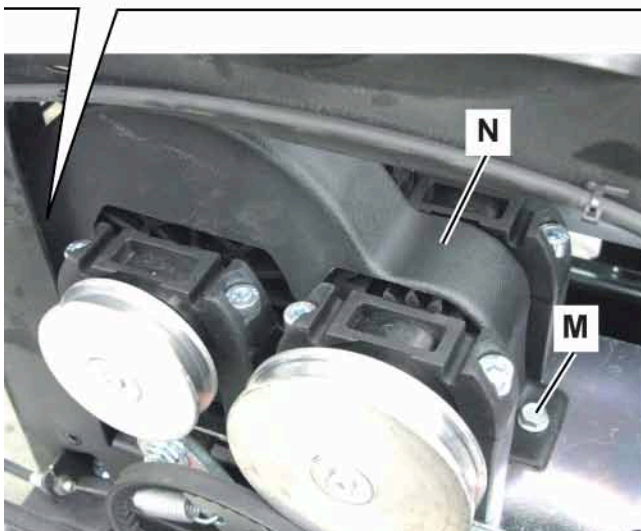
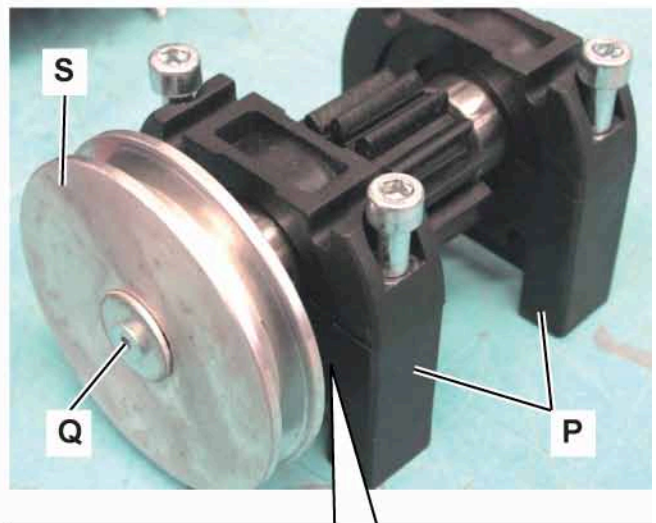
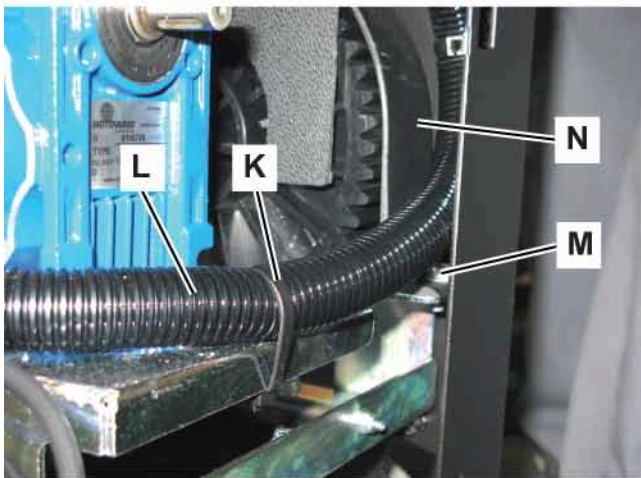
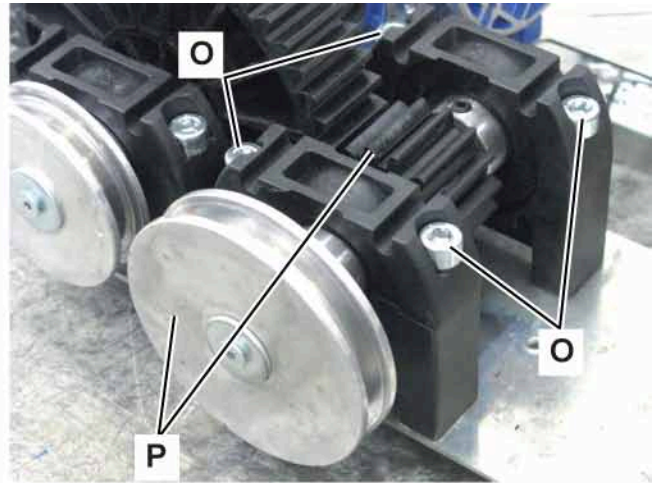

Main Broom Shaft (Small) Gear Removal/Installation (Continues)

13. Unscrew the two dowels (T) of the bearing.
14. Remove the assembly (U) from the shaft (X).
15. Remove the spacer (V).
16. Remove the gear (W) from the shaft with key (X).

Assembly

17. Assemble the gear in the reverse order of disassembly.

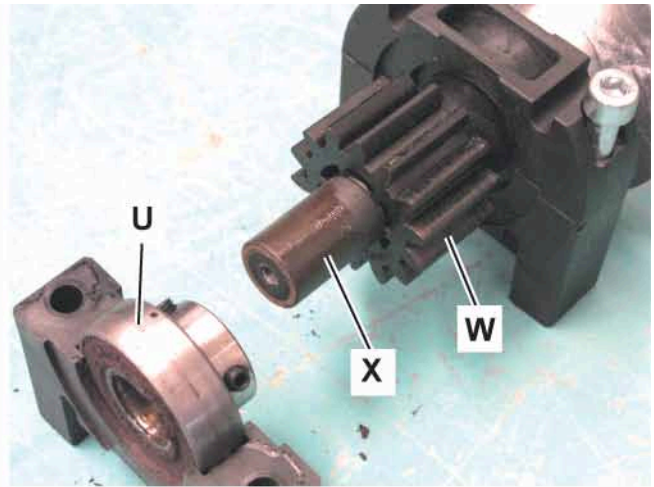
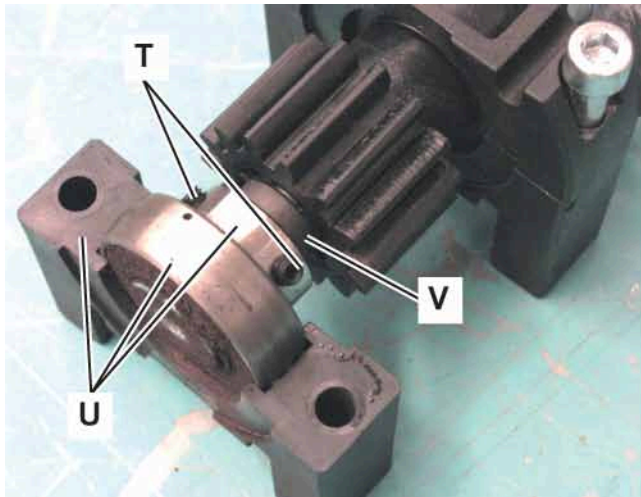

P200324

Drive Shaft (Big) Gear Removal/Installation

Disassembly

1. Drive the machine on a level floor and ensure that it cannot move.
2. Turn the ignition key to “0”.
3. Remove the hopper by using its transport handle and wheels.
4. Disengage the front fastener and open the battery/engine compartment hood.
5. Remove the screws (A) and the right side panel (B) from the machine.
6. Remove the rear grid (C) after removing the upper mounting screw (D) and disengaging the fasteners.
7. Turn the tensioner (E) in the direction shown by the arrow and disengage the belt (F) from the pulley (G).
8. Turn the tensioner (H) in the direction shown by the arrow and disengage the belt (I) from the pulley (J).

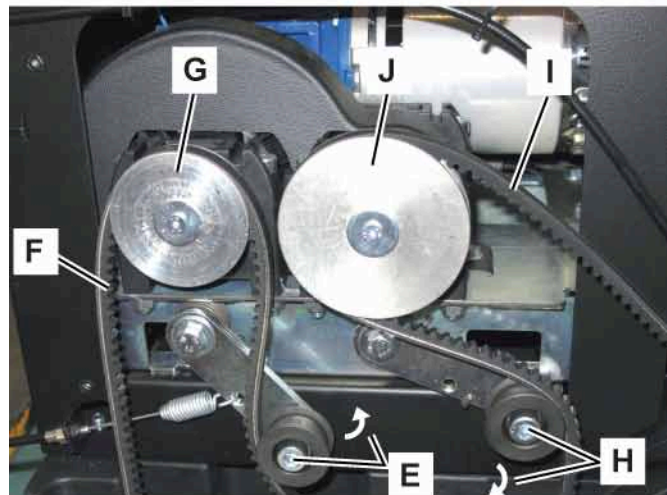
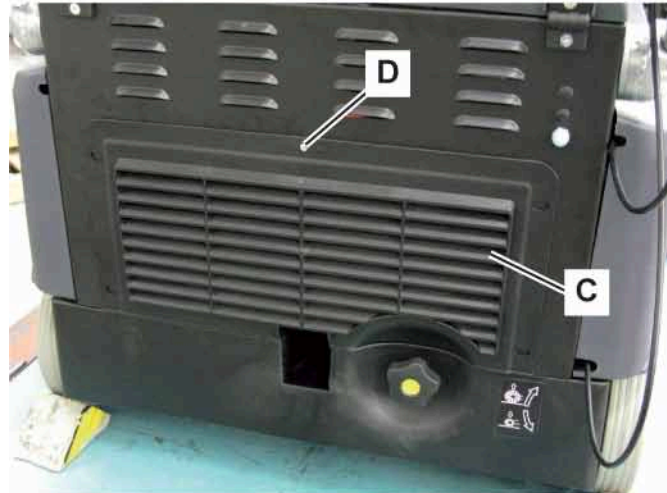

Drive Shaft (Big) Gear Removal/Installation (Continues)

9. Operating in the back side of the reduction unit, cut the clamp (K) fastening the wiring harness (L).
10. Remove the two screws (M) and remove the gear case (N).
11. Remove the two screws with nut (O) and then remove the half flange (P).

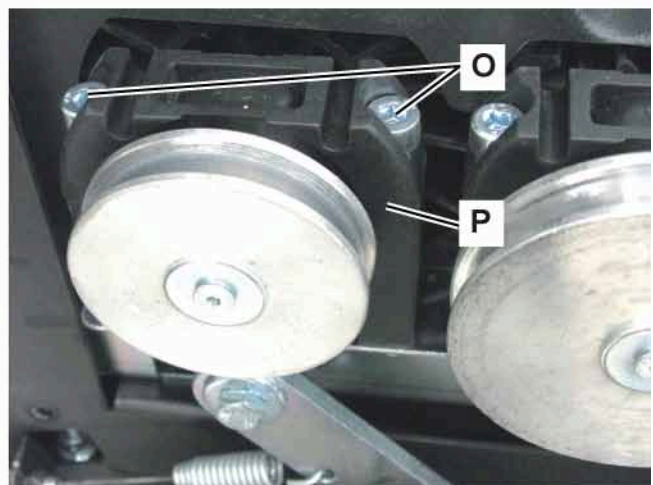
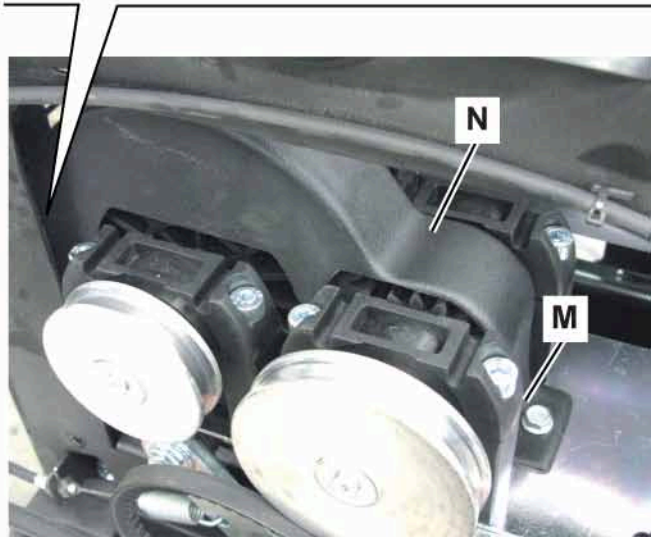
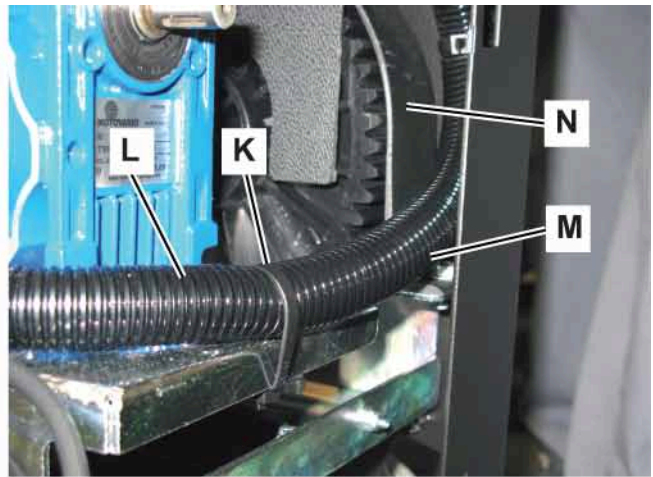

Drive Shaft (Big) Gear Removal/Installation (Continues)

12. Remove the screw (Q) on the inner side of the reduction unit.
13. Tighten the screw (R) on the threaded hole (S) of the reduction unit.
14. With a plastic mallet slightly tap on the screw (R) in the direction shown by of the arrow (T) until the gear assembly with shaft (U) comes out.
15. Remove the spacer (V) and the gear (W) from the shaft (X) with key.

Assembly

16. Assemble the gear in the reverse order of disassembly.

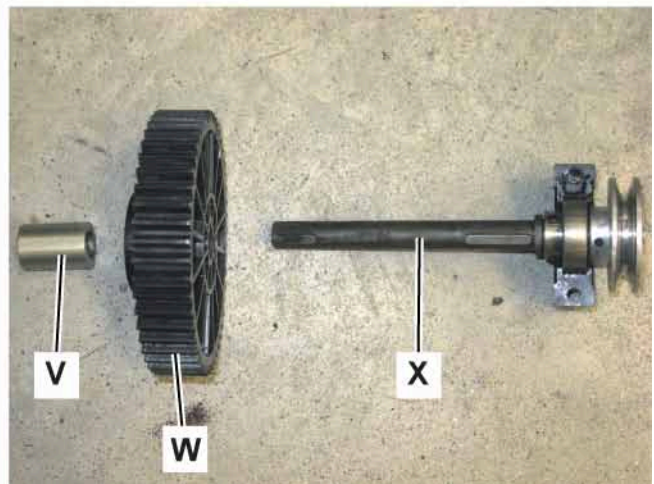
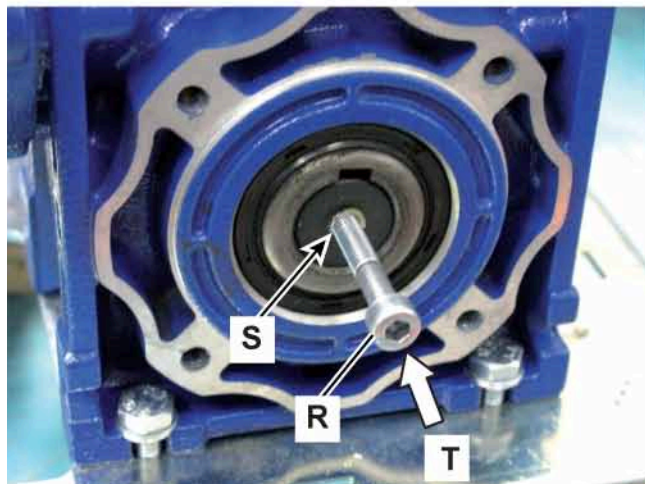
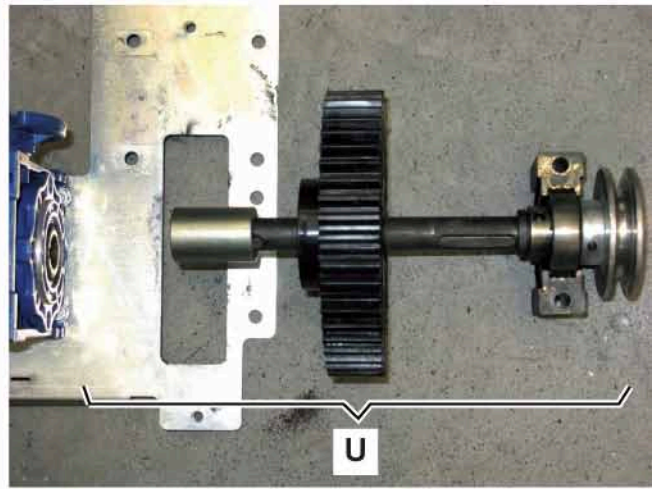
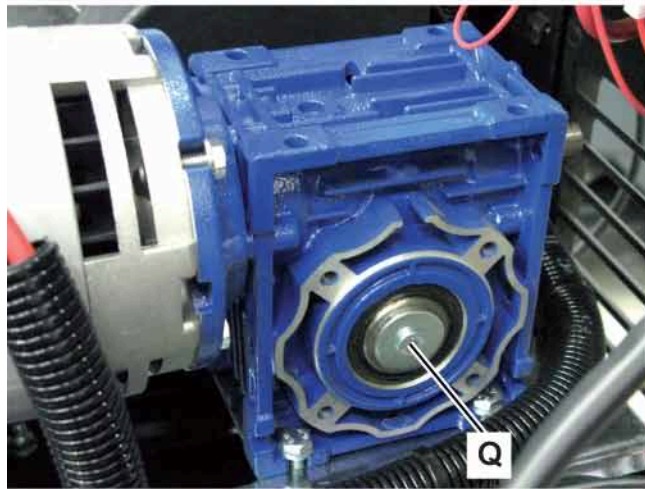
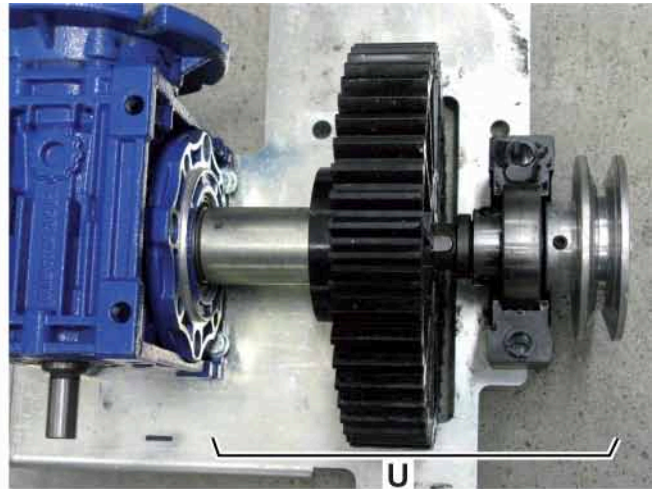

Battery Charger Removal/Installation (SW900 B)

Disassembly

1. Remove the batteries and their container (see the procedure in the relevant paragraph).
2. Remove the rear grid (A) after removing the upper mounting screw (B) and disengaging the fasteners.
3. Disconnect the electrical connector (C) from the battery charger (D).
4. Disconnect the electrical terminal (E) from the fuse.
5. Cut the fastening clamps (F) of the battery charger cables (G).
6. Disconnect the terminal (H) of the cable (G) from the battery terminal (-).

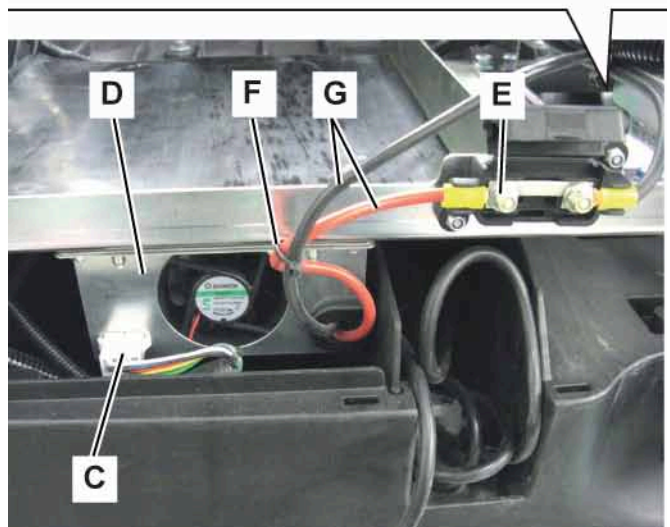
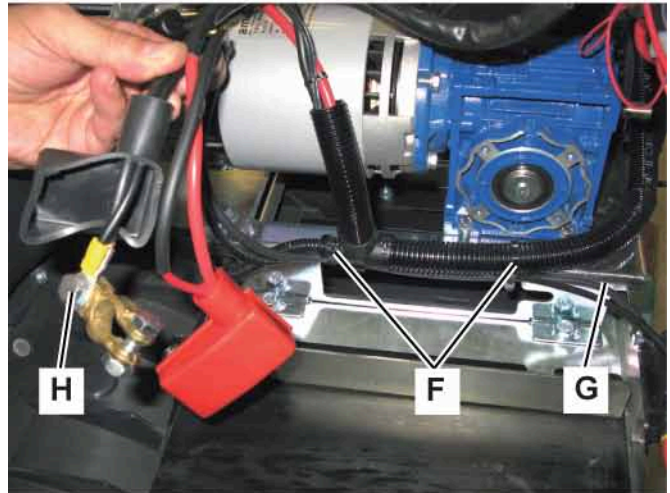
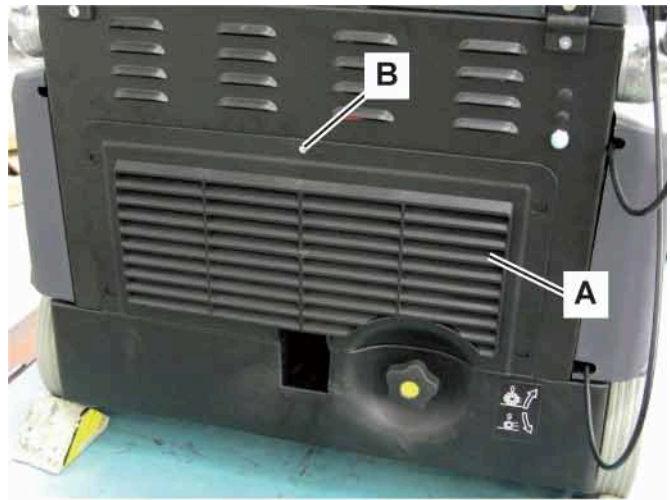

Battery Charger Removal/Installation (SW900 B) (Continues)

7. Lift the rubber mat (I) in the battery compartment.
8. Disconnect the battery charger electrical connector (J).
9. Remove the screws (K).
10. Remove the battery charger (L) by bringing it backward in the direction shown by the arrow (M), and then by lifting the front part in the direction shown by the arrow (N).

Assembly

11. Assemble the battery charger in the reverse order of disassembly and note the following:
 - When installing a new battery charger, this must be set according to the type of batteries which are going to be installed on the machine (see the procedure in the relevant paragraph). Set the battery charger before installing the batteries.

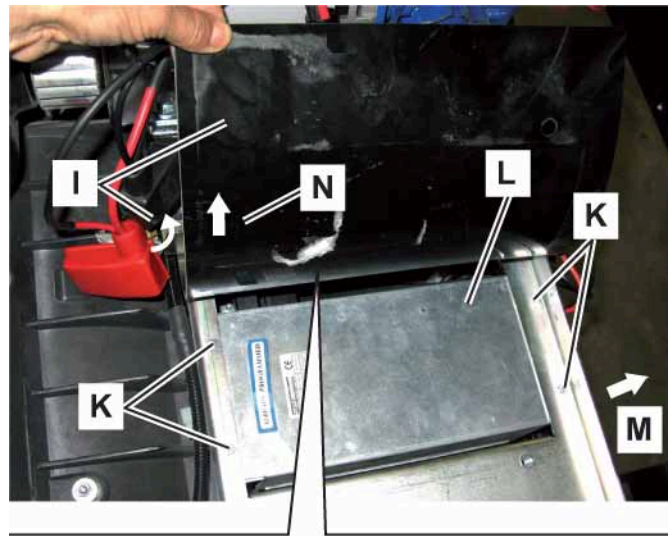

P200328

Hopper Position Switch Operation Check, Removal/Installation

Operation Check

1. Drive the machine on a level floor and ensure that it cannot move.
2. Turn the ignition key to “0”.
3. Remove the hopper by using its transport handle and wheels.
4. Turn the ignition key to “I”, then check that none of the machine functions can be operated; if the machine operates also when the hopper has been removed, adjust the hopper position switch as shown in the next paragraph.

Adjustment and Replacement

5. Disengage the front fastener and slightly lift the battery/engine compartment hood (A), then check that on the left side there is the tab (B) which activates the hopper position switch; if necessary, replace the battery/engine compartment hood.
6. Check that the inner vane (C) which activates the hopper position switch is integral, and swings freely in the direction shown by the arrow (E), and that the return spring (D) is working; if necessary, replace the part which is not working.
7. To adjust the position of the hopper position switch, proceed as follows.
8. Open the battery/engine compartment hood (A).

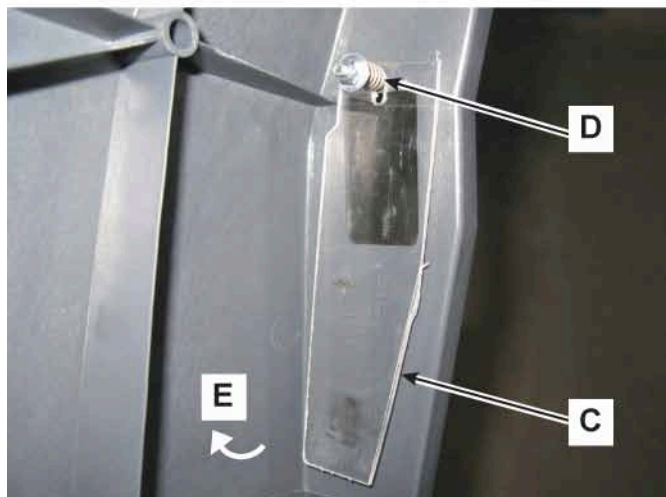
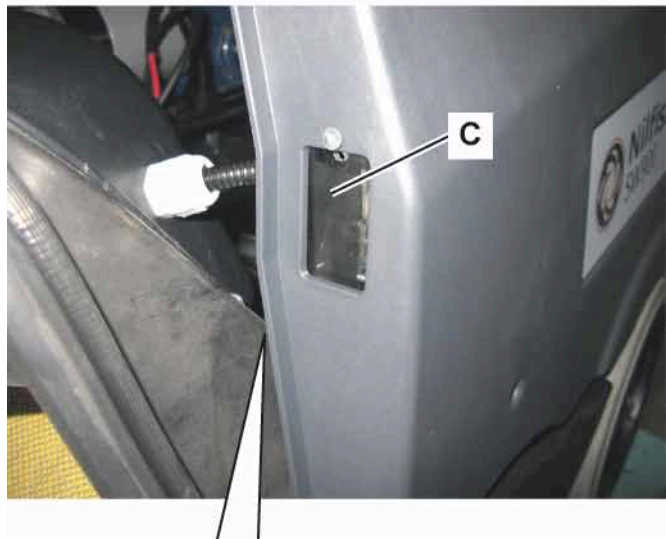
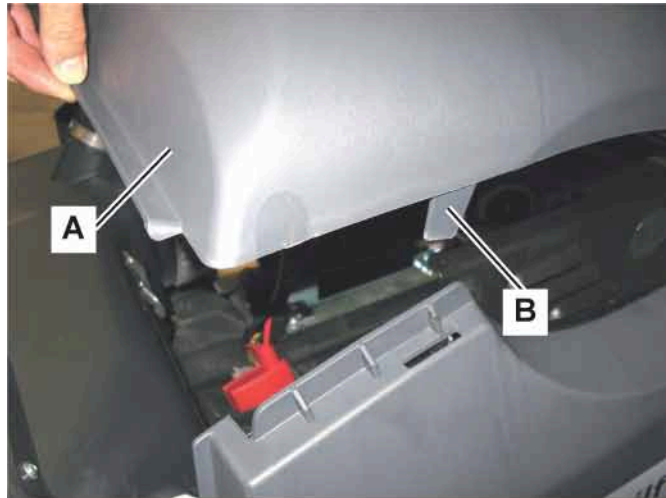

Hopper Position Switch Operation Check, Removal/Installation (Continues)

9. Remove the screws (F) and the left side panel (G).
10. Check that the arm (H) of the hopper position switch (I), swings freely on the pin (J), otherwise:
 - Remove any dirt causing malfunction
 - Loosen the inner locknut (L) and adjust the screw (K); when the adjustment is completed, tighten the locknut (L)
11. If necessary, loosen the screws (M) and adjust the position of the switch (I) by moving it in the direction shown by the arrow (N); when the adjustment is completed, tighten the screws (M).
12. If necessary, remove the screws (M) and disconnect the electrical connections (O), then remove and replace the switch (I); then adjust the hopper position switch (I) (see the previous steps).

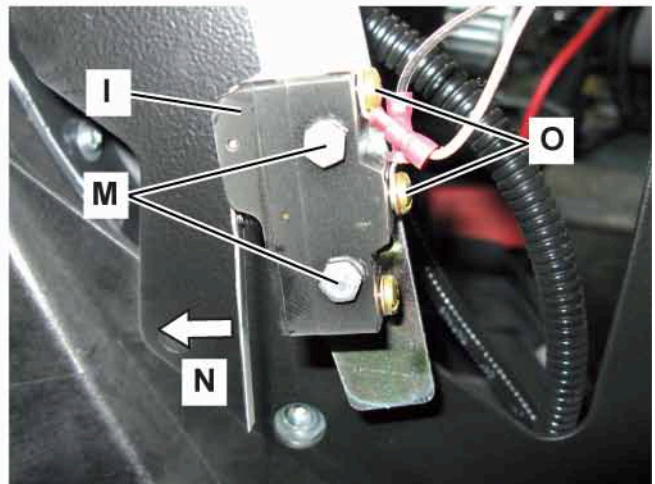
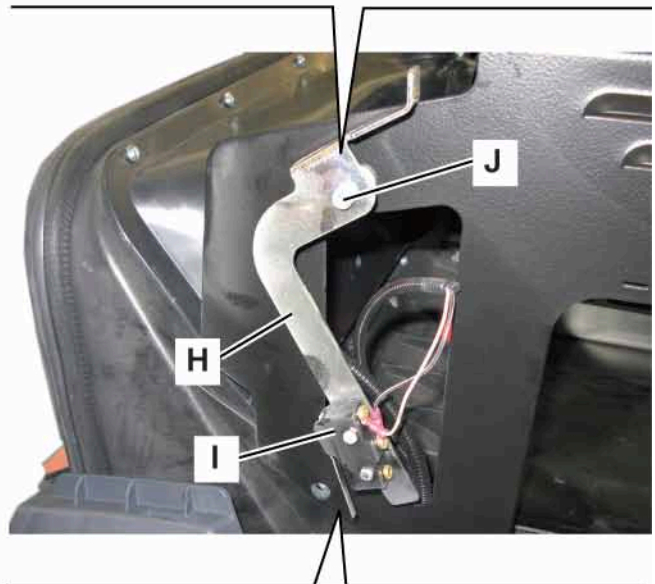
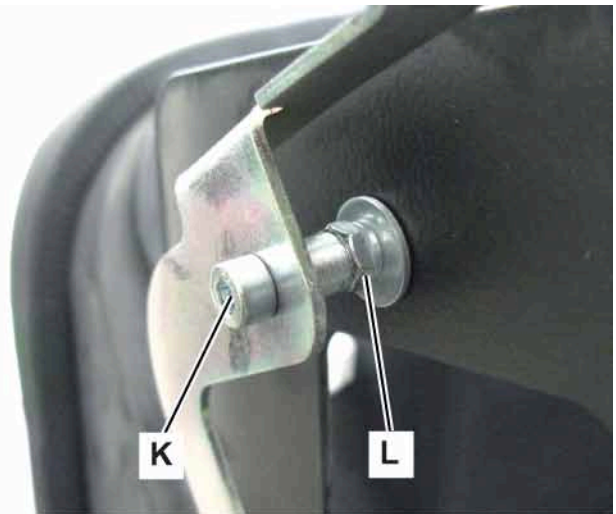

Specifications

Model		Advance / Nilfisk SW900 B	Nilfisk SW900 P
Power		12V batteries	-
Main motor	power (drive/main broom/vacuum system)	0.9 hp (680 W)	-
Dynamotor	power (drive/main broom/vacuum system)	-	0.26 hp (198 W)
Total absorbed power		1.02 hp (0.76 kW)	-
Working autonomy		3 h	1.5 h
Dimensions (length x width x height)	battery compartment	12.9 x 9 x 15 in (327 x 230 x 380 mm)	
IP protection class		X3	

Petrol Engine System

Functional Description

The engine system generates electric current for all machine electrical functions.

The assembly consists of an internal combustion engine and dynamotor, which are both connected by a belt.

The engine is a single-cylinder air-cooled petrol type. The engine start-up is made by means of a self-winding system.

The engine speed is fixed to 2,950 rpm, to grant a constant current to the electrical system.

The fuel tank is applied to the engine. The tank is equipped with a valve with integrated filter.

Wiring Diagram

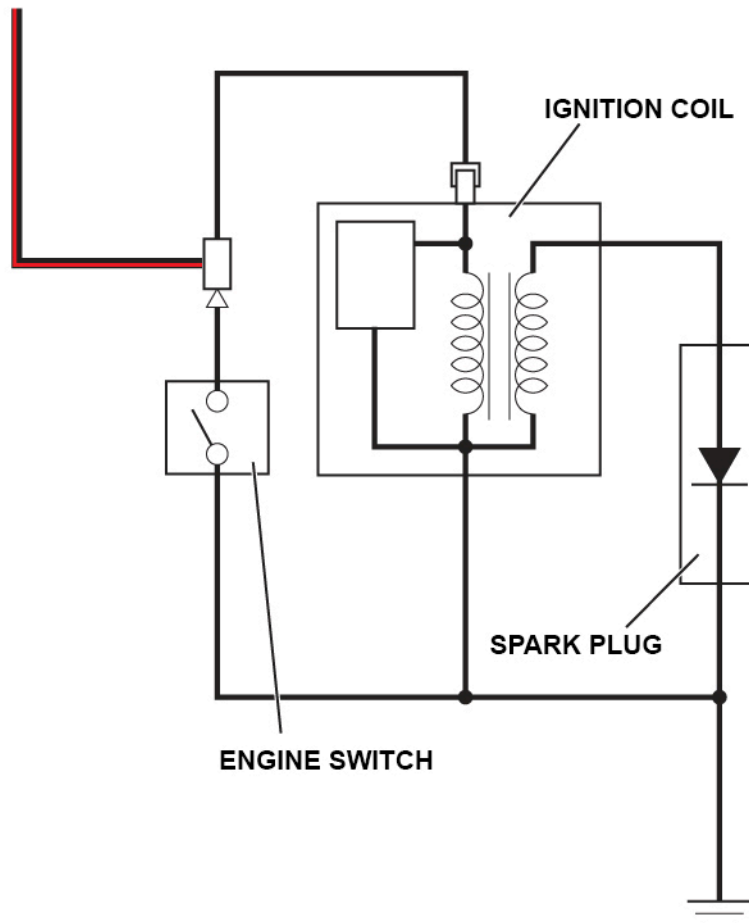

Component Locations

- Petrol engine
- Engine switch
- Engine oil filler plug
- Engine oil drain plug
- Engine belt
- Engine oil level outer check plug
- Engine oil level inner check plug

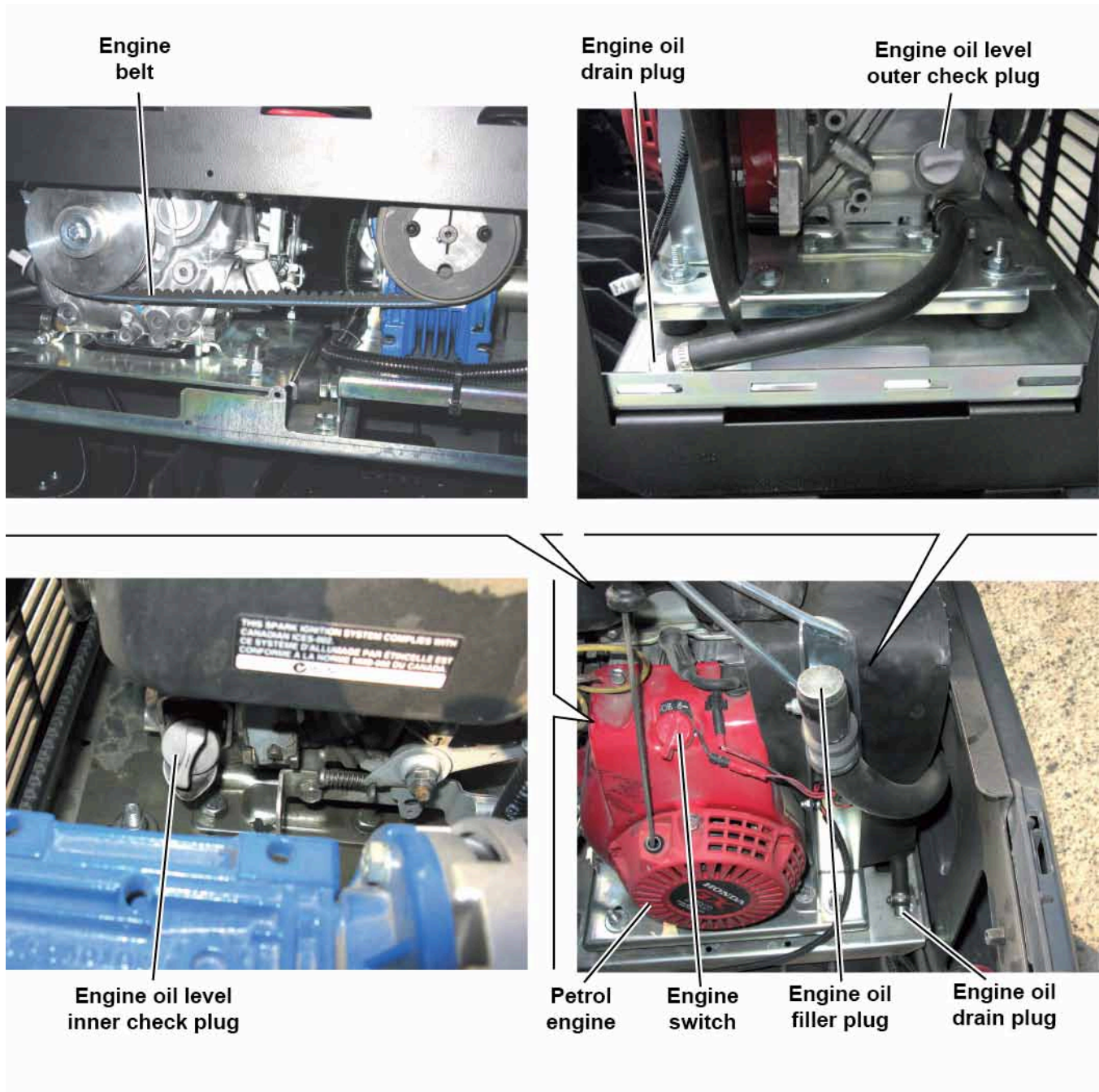

Maintenance and Adjustments

Engine RPM Check and Adjustment

Check

1. Drive the machine on a level floor and ensure that it cannot move.
2. Turn the ignition key to “0”.
3. Remove the rear grid (A) after removing the upper mounting screw (B) and disengaging the fasteners.
4. Apply on the engine pulley (C) an adhesive indicator (D) for counting the engine speed.
5. Turn the ignition key to “I” and start the petrol engine (as shown in the User Manual); wait 5 - 10 minutes that the engine reaches the target speed.

6. Point a revolution counter on the adhesive indicator (D) of the engine pulley (C), then detect the engine speed, which must be $3,000 \pm 50$ rpm.

If necessary, adjust the engine speed as shown below.

Adjustment

7. Turn the ignition key to “0”.
8. Remove the hopper by using its transport handle and wheels.

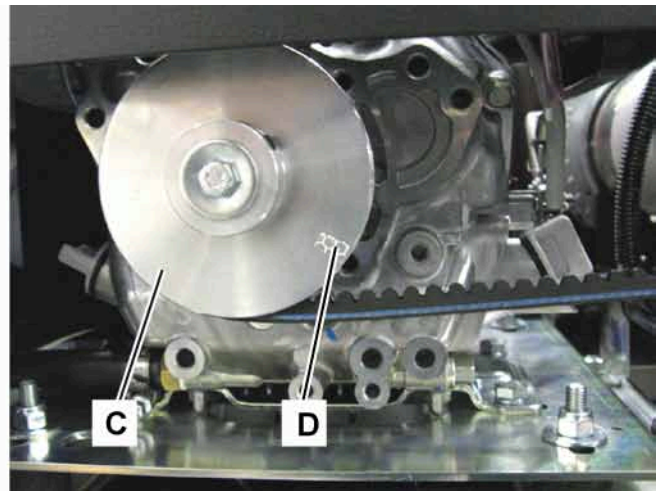
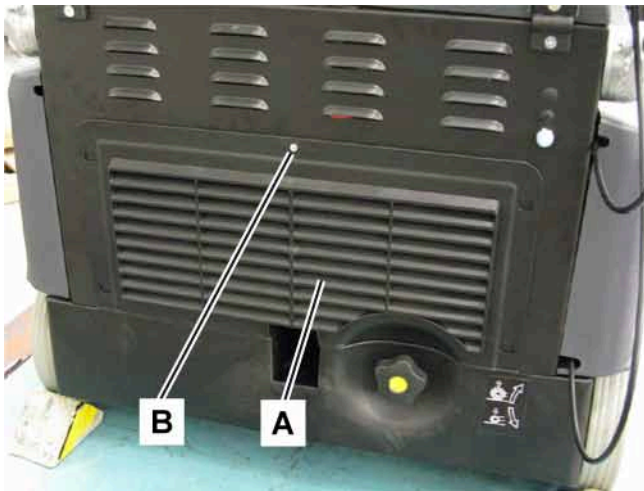

P200284

Engine RPM Check and Adjustment (Continues)

9. Carefully operate and keep operated, the hopper position microswitch (E) (to simulate the presence of the hopper).
10. Turn the ignition key to “I” and start the petrol engine (as shown in the User Manual); wait that the engine warms up and reaches the target speed.



Warning! Perform the following procedures with extreme care, and remind that the petrol engine is running.

11. Carefully disengage the front fastener and open the engine compartment hood.
12. Carefully loosen the nut (F) and move the lever (G) as necessary to adjust engine rpm and refer to the plate (H) for the direction of movement. After adjusting, tighten the nut (F).

Reassembly

13. Turn off the petrol engine (as shown in the User Manual).
14. Turn the ignition key to “0”.
15. Close the engine compartment hood and engage the front fastener.
16. Release the hopper position microswitch (E) from the forced operation, and check that the microswitch operates properly.
17. Install the hopper by using its transport handle and wheels.
18. Install the rear grid (A) by engaging the fasteners and then tighten the upper mounting screw (B).

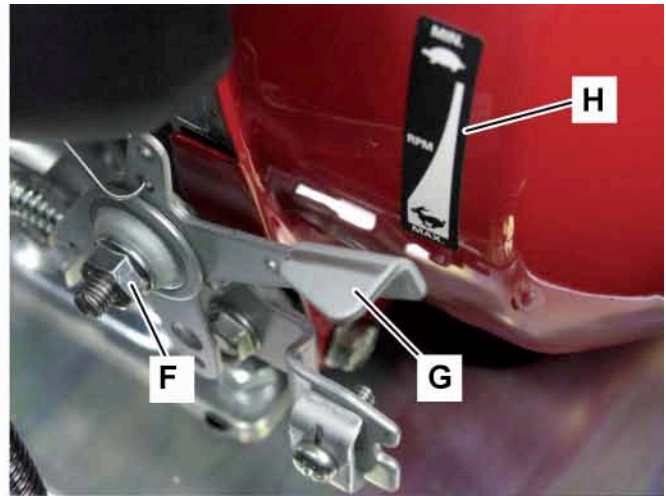
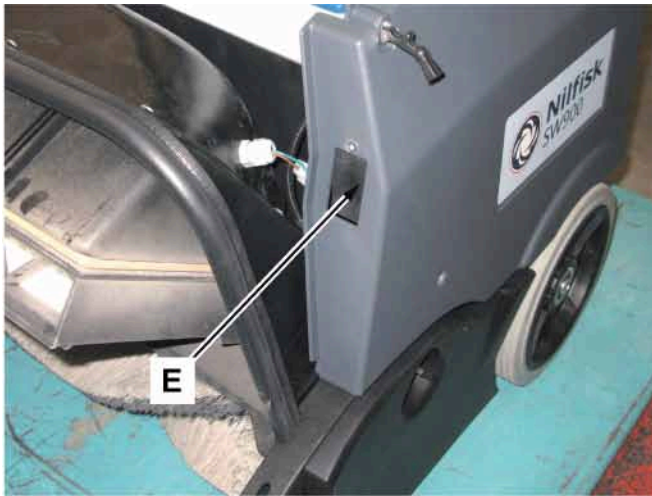

Troubleshooting

Trouble	Possible causes	Remedy
The engine does not start when pulling the handle.	The ignition key is not turned to "I".	Turn the ignition key to "I".
	The fuel valve is closed.	Open the fuel valve.
	The fuel tank is empty.	Refuel.
	The hopper or the upper hood is not in its proper position.	Adjust.
	The fuel does not reach the carburetor.	Check if the fuel reaches the carburetor.
	The spark plug does not produce a spark.	The spark plug does not produce a spark.
	The hopper microswitch is broken.	Replace the microswitch.
The engine stops during operation.	The engine oil level is insufficient.	Add engine oil.
	The fuel tank is empty.	Refuel.
	The hopper microswitch is broken.	Replace the microswitch.
The engine does not start	The fuel valve is closed (OFF position).	Turn the lever to ON position.
	The choke lever is open.	Turn the lever to CLOSED position unless the engine is hot.
	The fuel quality is poor; the engine has been stored without performing fuel treatment or without draining it; the machine has been re-fuel with poor quality gasoline.	Drain the fuel tank and the carburetor. Refuel with fresh gasoline.
	The fuel tank is empty.	Refuel.
	The spark plug is damaged, dirty or the distance between the electrodes is wrong.	Correct the distance between the electrodes or replace the spark plug.
	The spark plug is wetted with fuel (flooded engine).	Dry the spark plug and reinstall it. Start the engine with the throttle lever to MAX position, and the choke lever to OPEN position.
	The fuel filter is clogged, the carburetor is broken, the start system is broken, the valves are locked, etc.	Replace or repair the damaged parts as necessary.
The engine loses power.	The filter element or elements are clogged	Clean or replace the filter elements.
	The fuel quality is poor; the engine has been stored without performing fuel treatment or without draining it; the machine has been re-fuel with poor quality gasoline.	Drain the fuel tank and the carburetor. Refuel with fresh gasoline.
	The fuel filter is clogged, the carburetor is broken, the start system is broken, the valves are locked, etc.	Replace or repair the damaged parts as necessary.

Removal and Installation

Engine Belt Check/Adjustment/Replacement

Check and adjustment

1. Drive the machine on a level floor and ensure that it cannot move.
2. Turn the ignition key to “0”.
3. Remove the rear grid (A) after removing the upper mounting screw (B) and disengaging the fasteners.
4. Check the entire length of the engine belt (C) to make sure it is intact and shows no signs of cuts, tears or cracks. If necessary, replace the belt.
5. Check the proper tension of the belt, which can occur when pressing the belt in middle area between the two pulleys, with a force (D) of approximately 1 Kg, the belt is moving of an arrow (E) of 15-20 mm.

If necessary, adjust the belt tension as shown below:

- Loosen the four mounting screws (F) of the engine assembly (H) to the holder (G), then move the engine assembly as necessary; when the proper tension is reached, tighten the four screws (F).
6. If necessary, also check the correct alignment of the engine pulley (I) with the reduction unit pulley (J), as shown below:
 - Remove the hopper by using its transport handle and wheels.

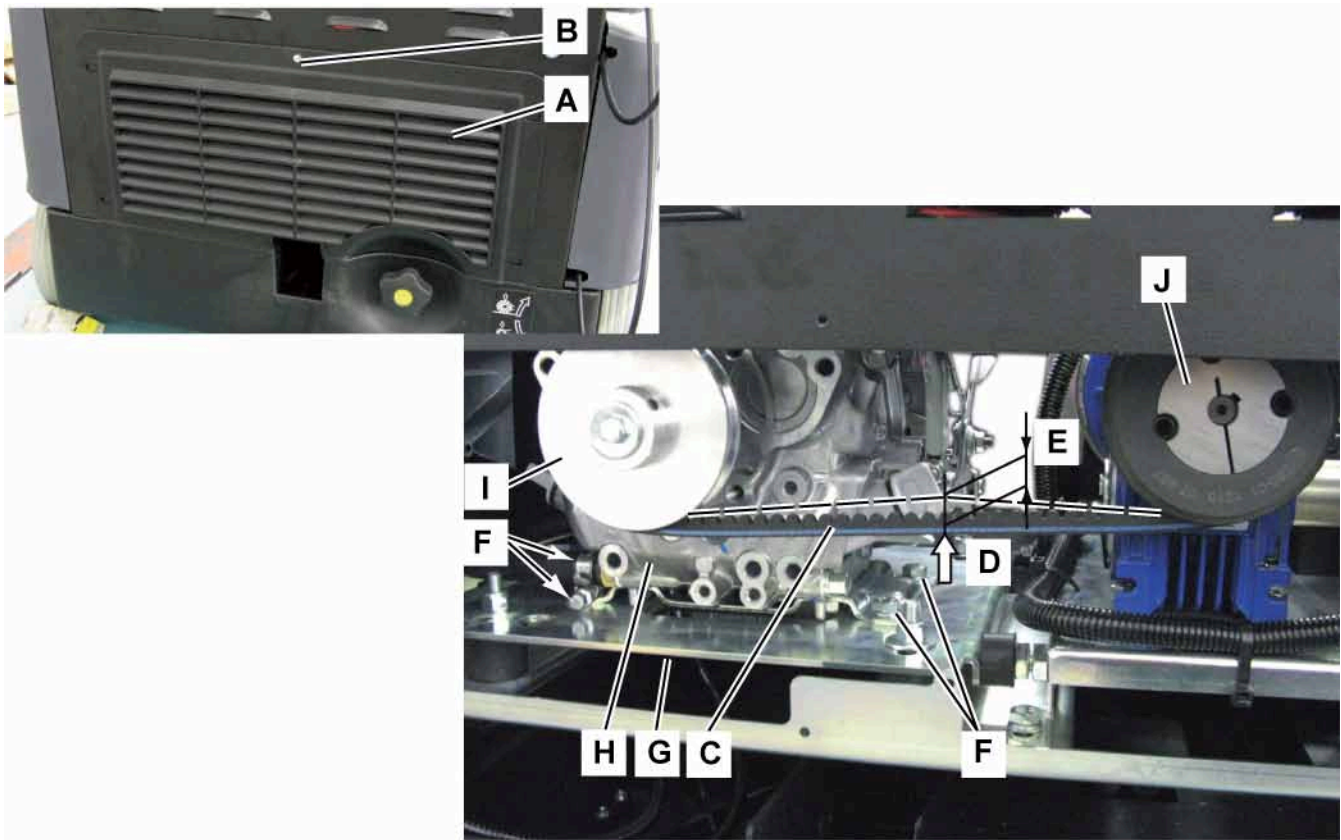

Engine Belt Check/Adjustment/Replacement (Continues)

- Disengage the front fastener and open the engine compartment hood.
 - On the upper side of the machine, insert a ruler (K) in contact with the inner surfaces of the engine pulley (I) and the reduction unit pulley (J), then check for the proper alignment.
 - If necessary, adjust the alignment as shown below:
 - Loosen the four nuts (L) fastening the engine holder (G) to the vibration-dampers, then adjust the alignment of the two pulleys by sliding the plate (G) with engine assembly; when the adjustment is completed, tighten the nuts (L).
7. The pad (M) must slightly contact the holder (G), then if necessary, adjust its position by adjusting the locknut (N) and the nut (P); when the adjustment is completed, tighten the nuts.

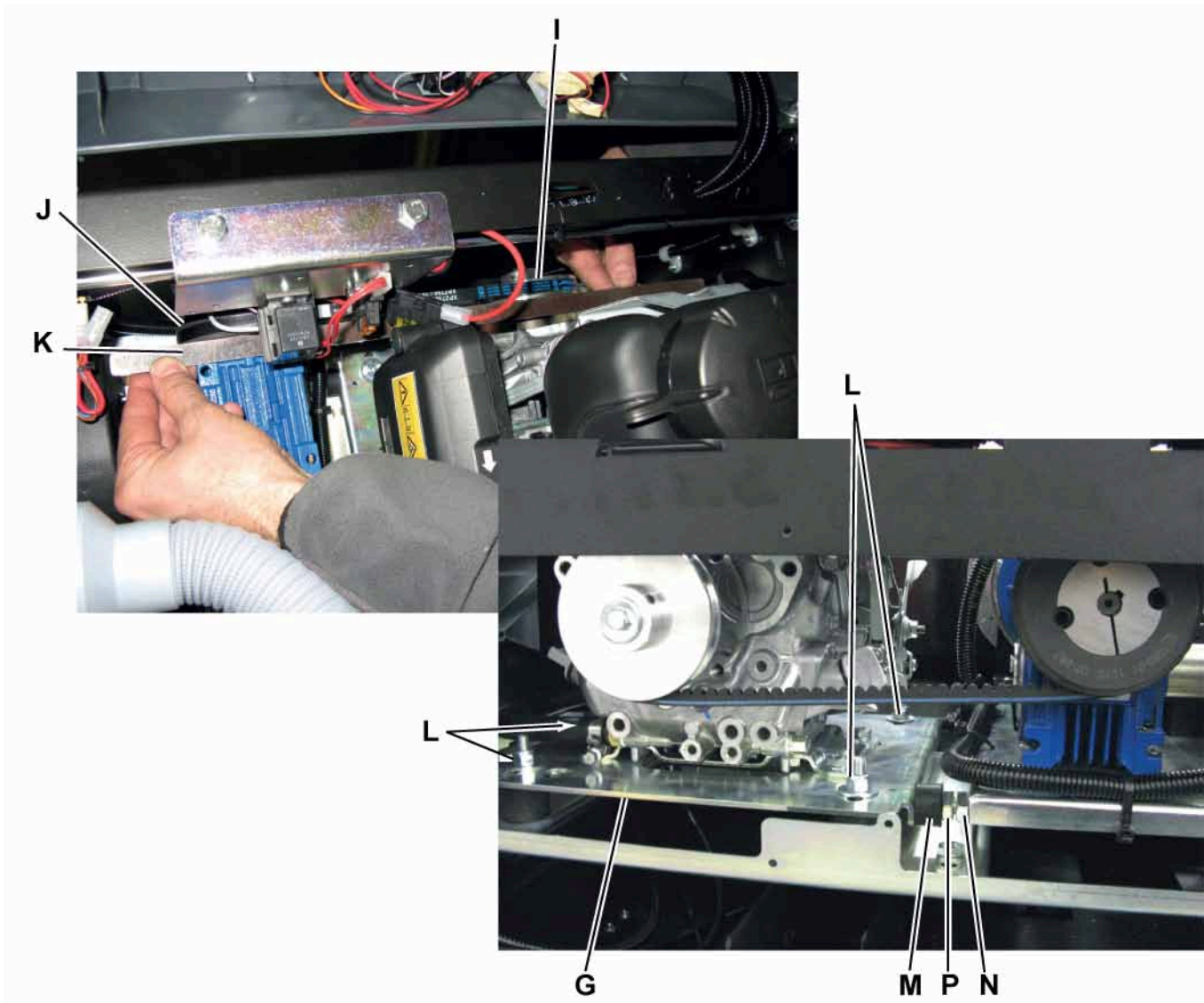

Engine Belt Check/Adjustment/Replacement (Continues)

Replacement

1. Drive the machine on a level floor and ensure that it cannot move.
2. Turn the ignition key to “0”.
3. Remove the rear grid (A) after removing the upper mounting screw (B) and disengaging the fasteners.
4. Loosen the four screws (F) fastening the engine assembly (H) to the holder (G), then move the engine assembly toward the dynamotor as possible.

Disengage the engine belt (C) from the engine pulley (I) using a screwdriver as a lever and by simultaneously turning the engine pulley (I) by slightly pulling the engine pull-start cord.

Retrieve the engine belt (C) by disengaging it from the reduction unit pulley (J).

5. Install the new belt (C) by engaging it on the pulleys (I) and (J).
6. Adjust the belt (See “**Check and Adjustment**” paragraph in this procedure).

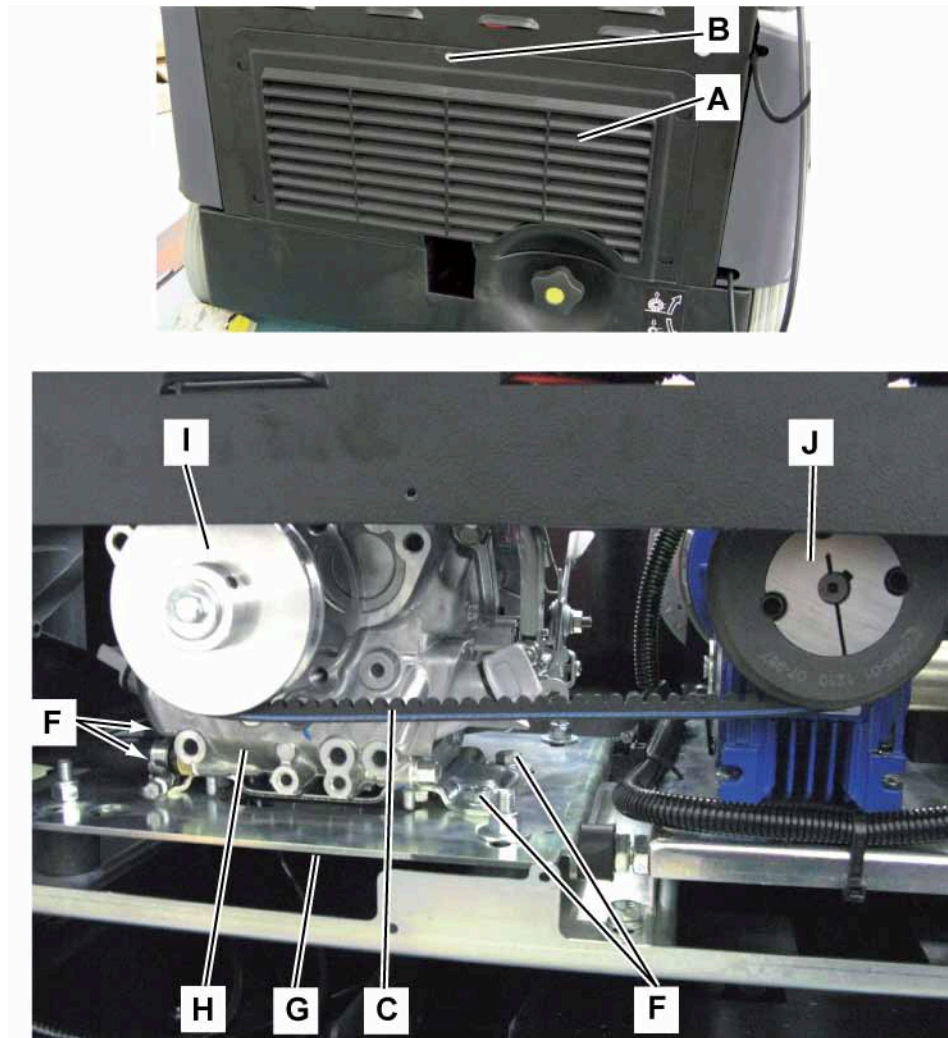

Petrol Engine Assembly Removal/Installation

Disassembly

1. Drive the machine on a level floor and ensure that it cannot move.
2. Turn the ignition key to “0”.
3. Remove the hopper by using its transport handle and wheels.
4. Disengage the front fastener and open the engine compartment hood.
5. Disconnect the engine electrical connections (A) and (B).
6. Open the fastening clamp (C) and disconnect the engine ground (D).
7. Remove the rear grid (E) after removing the upper mounting screw (F) and disengaging the fasteners.
8. Remove the screws (G) and the bulkhead (H).
9. Disengage the engine belt (I) from the engine pulley (J) using a screwdriver as a lever and by simultaneously turning the engine pulley (J) by slightly pulling the engine pull-start cord.
10. Loosen the four nuts (K) fastening the engine holder (L) to the vibration-dampers.

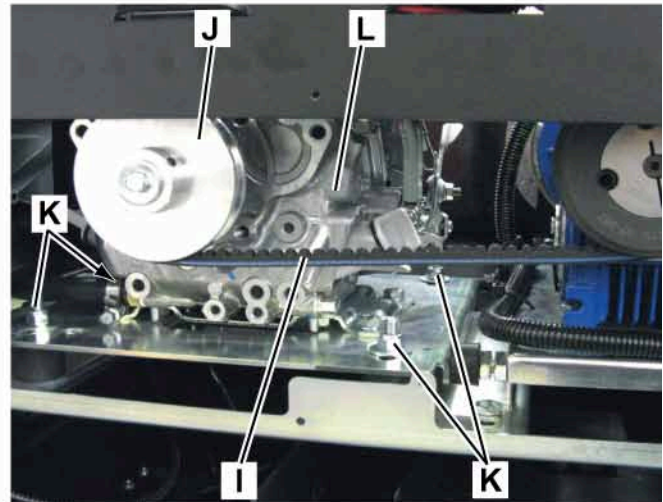
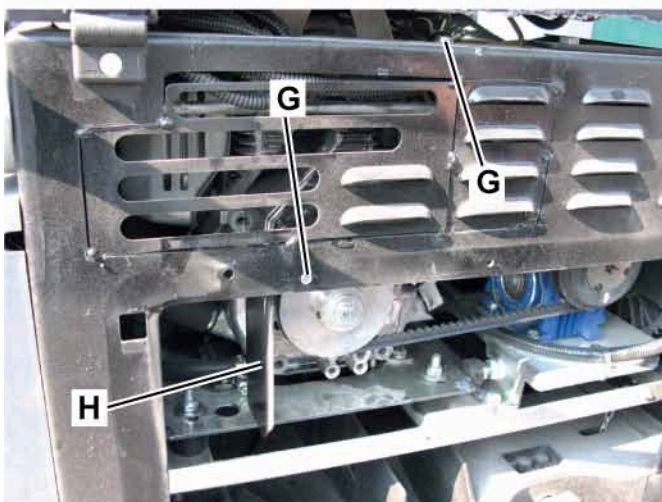
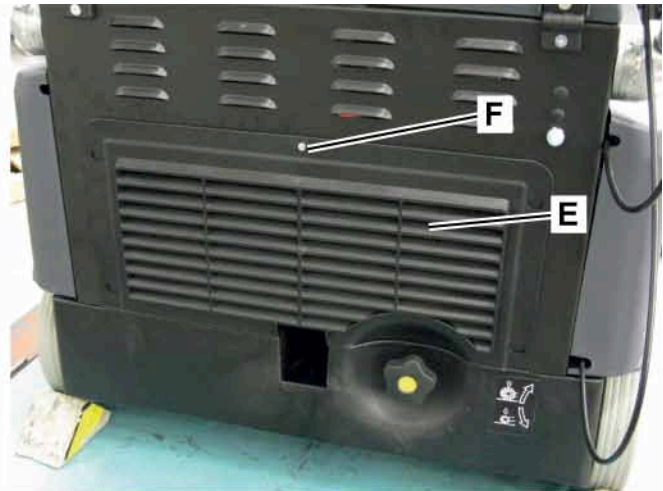
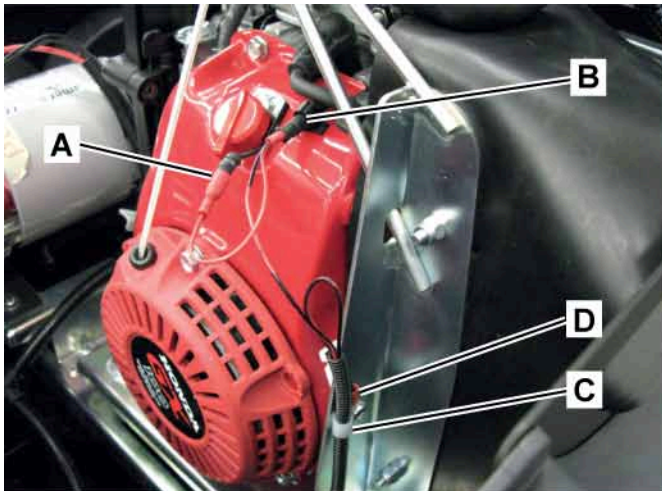

Petrol Engine Assembly Removal/Installation (Continues)

11. Carefully lift and remove the engine assembly (M) (engine weight: 10.9 Kg approx.).

If necessary, at the workbench separate the following parts from the engine (N):

- Guard (P)
- Oil drain hose (Q)
- Engine pulley (R)
- Engine holder (S)

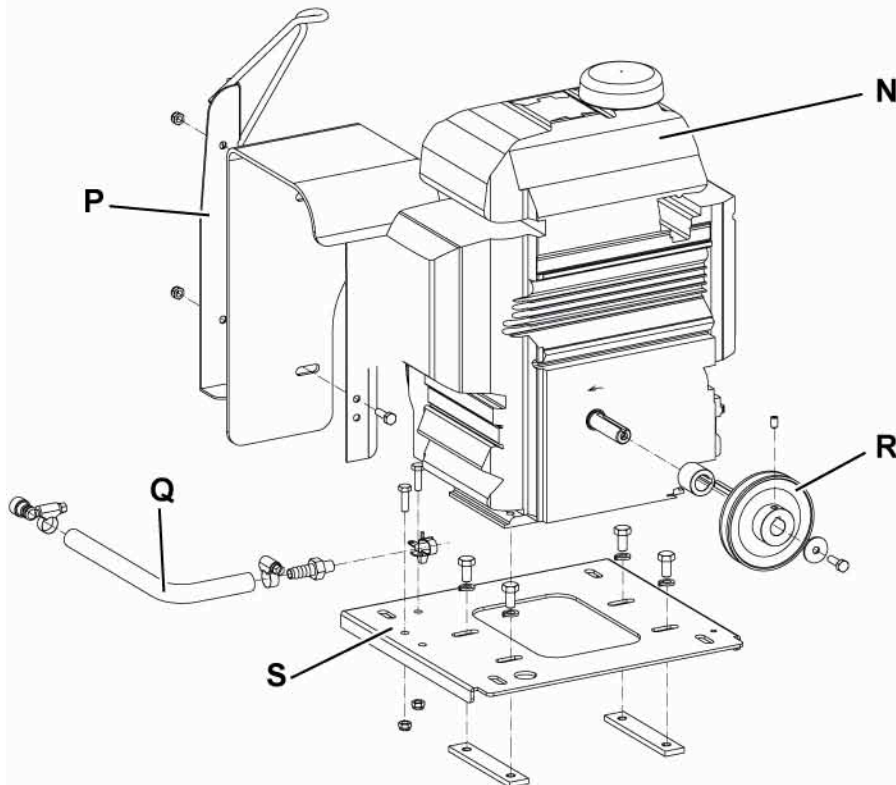

Petrol Engine Assembly Removal/Installation (Continues)

Assembly

12. Assemble the components in the reverse order of disassembly, and note the following:

- After assembling the engine belt, perform the belt check/adjustment (see the procedure in the relevant paragraph).
- When installing a new engine:
 - Check if there is oil in the engine.
 - Check for proper alignment of the engine exhaust pipe (W) to the machine exhaust end pipe (X); if necessary loosen the screws (Y) and adjust. Then tighten the screws (Y).
 - Remove the three screws (S) and turn the case (T) for 120° to turn the outlet hole (U) of the engine pull-start cord (V) in the position shown in the figure. Tighten the screws (S).

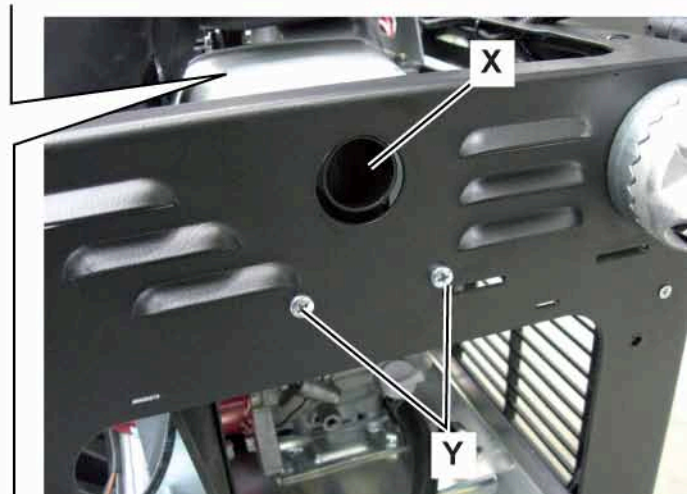
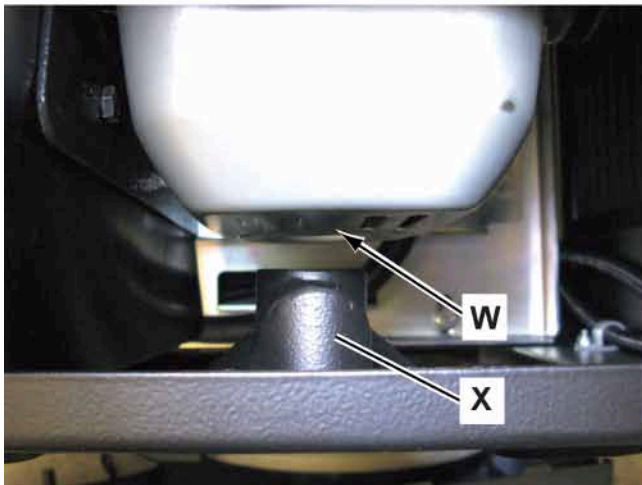
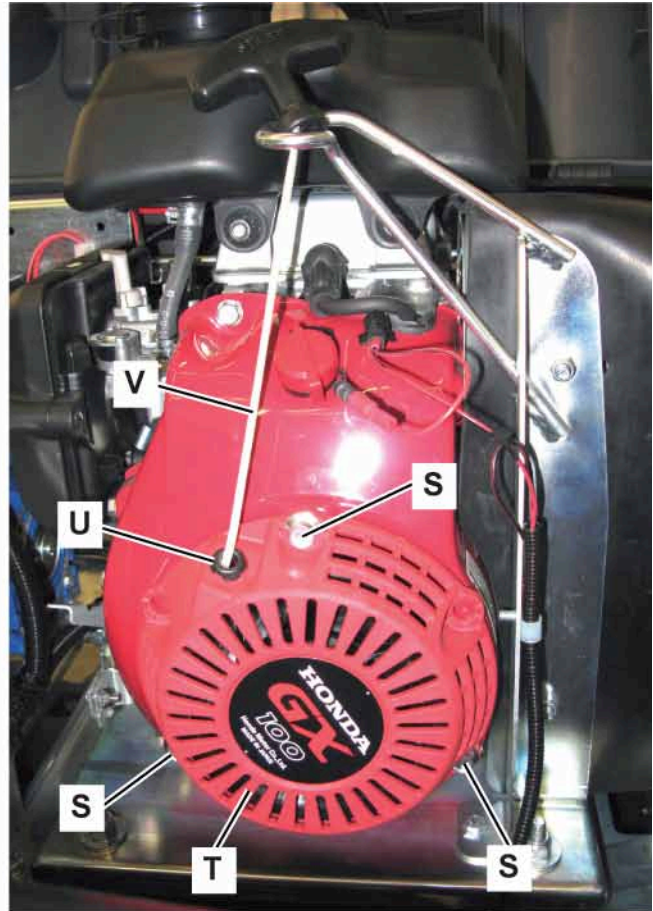

Petrol Engine Assembly Removal/Installation (Continues)

- Connect the engine electrical cables (A) and (B), as shown in the figure.
- Check the engine oil level (as shown in the User Manual).
- Check the engine rpm (see the procedure in the relevant paragraph)

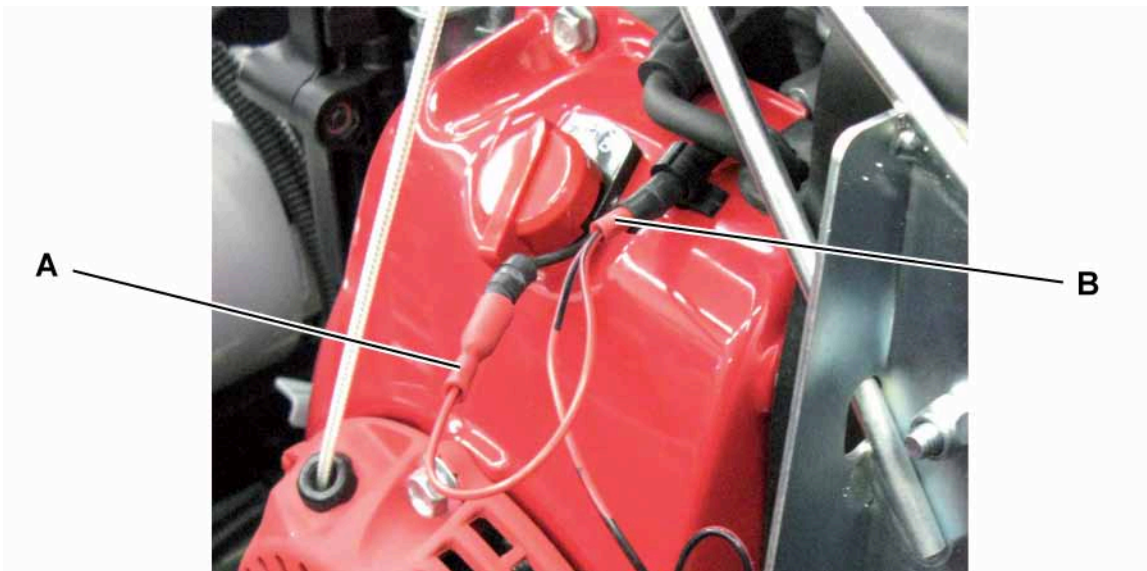

Specifications

Model	Nilfisk SW900 P
Power	2.1 kW @ 3,600 rpm
Engine model	Honda GX-100
Number of cylinders	1
Displacement	98
Bore x stroke	40 x 56
Compression ratio	8.5:1
Cooling	Air
Fuel	Gasoline
Cycle	Cycle 8
Maximum engine speed (max power)	3,600 rpm (2.1 kW)
Minimum engine speed (min power)	2,000 rpm (1 CV)
Fuel consumption at 2,500 rpm	390 g/hour
Fuel consumption at 3,600 rpm	Fuel consumption at 3,600 rpm
Oil pan capacity	1,514 gal (0.4 L)
Engine oil type	SAE 10W30
Emission certifications	VCA - Cert. No.: e11*97/68SA*2002/88*0305*01
Fuel tank capacity	0.77 liters
Engine oil type	SAE 10W30

Hopper System

Functional Description

The hopper normally resides in its seat in the frame. It can be removed from its seat by using its lifting and transport handle.

The hopper can be dragged on the wheels provided for the transport, to reach the discharge area.

To lift the hopper, in addition to the transport handle, there is a handle (x-x-x-x-x-) to grab it properly.

The hopper is provided with two skirts, a front skirt for debris collection and an intermediate one, to protect the filter from the material launched from the main broom and to help the filter powders to fall into the hopper itself.

Component Locations

- Hopper
- Dust filter protection skirt
- Front skirt

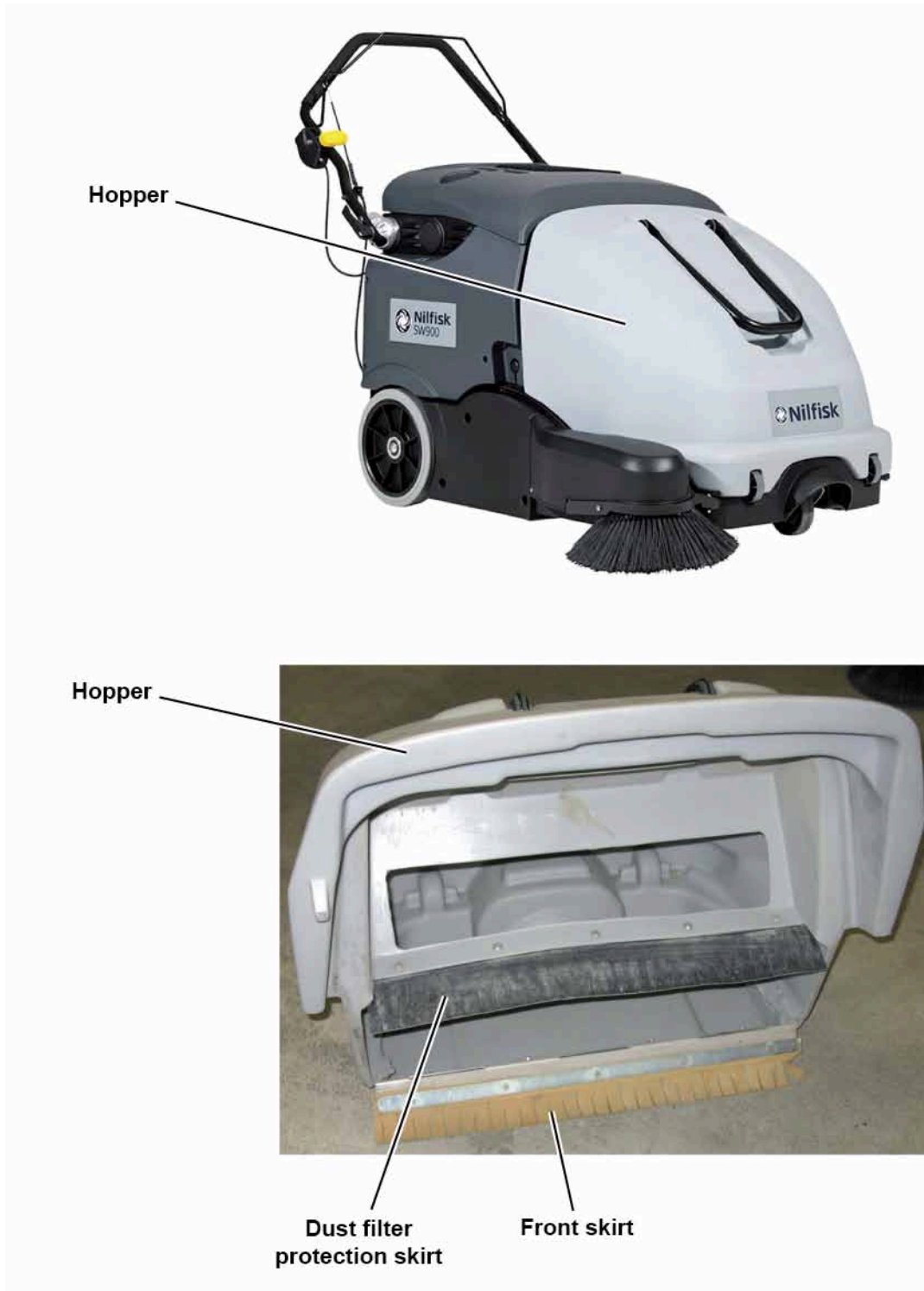

Specifications

Model		Advance / Nilfisk SW900 B	Nilfisk SW900 P
Hopper	Real capacity	0.88 ft ³ (25 Liters)	
	Theoretic capacity	2.8 ft ³ (79 Liters)	
	Maximum transportable weight	66 lb (30 kg)	

Main Broom System

Functional Description

The machine start-up, determines the operation of the main broom which is held in a pivoting support fastened on the frame.

The broom is made to rotate by the reduction unit to which is connected a pulley with an hexagonal drive hub. On the opposite side the broom is supported by a idle hub fixed to a plate stuck to the broom holder.

The knob in the rear side of the machine determines the broom lowering/lifting and therefore the relevant pressure on the floor.

The door on the left side of the machine can be opened with the foldable lever, so that the idle hub mounting plate can be reached.

By loosening the two knobs fastening the mounting plate to the broom holder, the idle hub can be removed by releasing the main broom which can be removed after removing the hopper.

Wiring Diagram

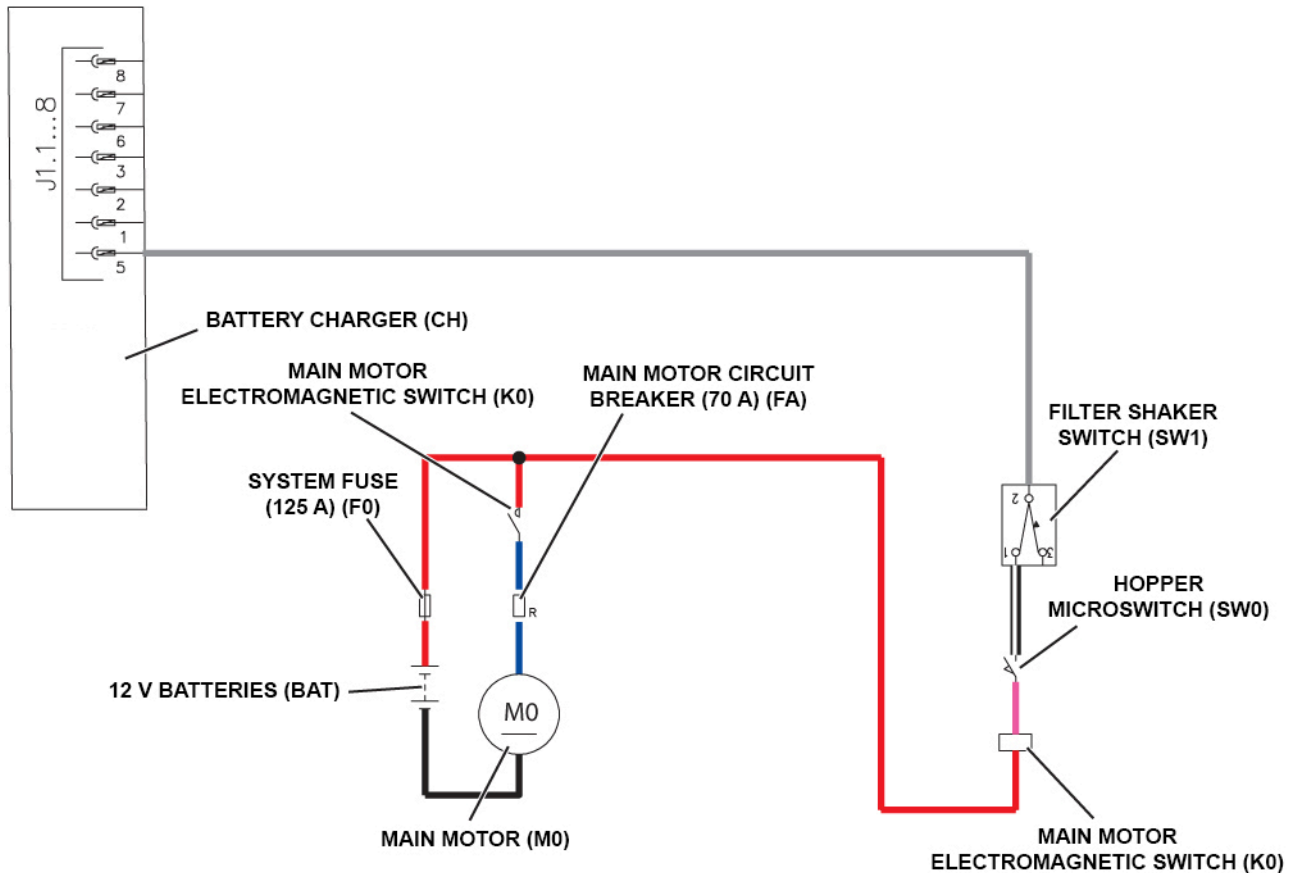

Component Locations

- Main broom
- Main broom belt
- Pulley with hexagonal drive hub
- Hexagonal drive hub
- Main broom height adjusting knob
- Front skirt
- Rear skirt
- Right side skirt
- Right side recovery skirt
- Left side skirt
- Left side recovery skirt

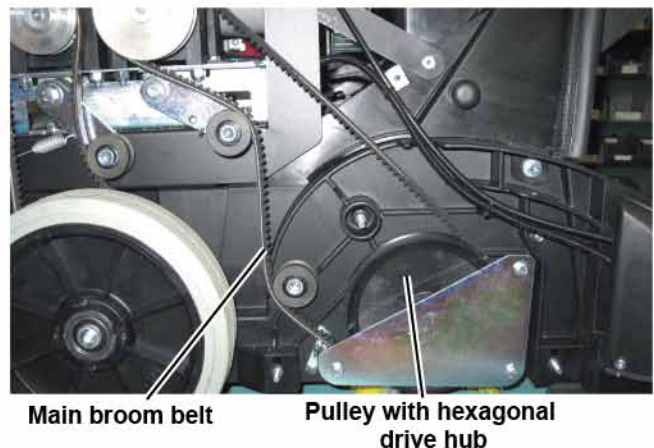
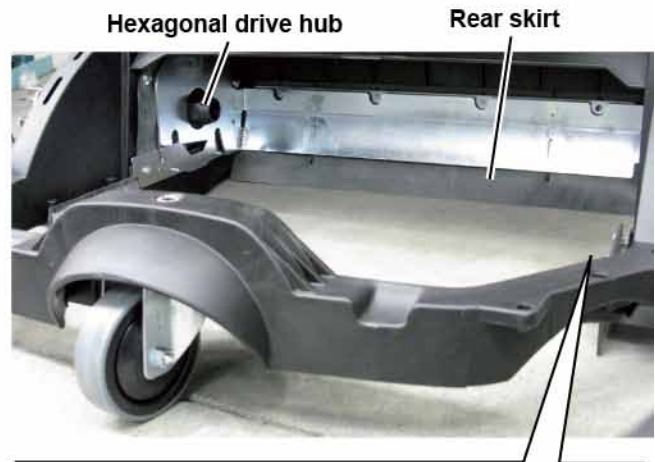
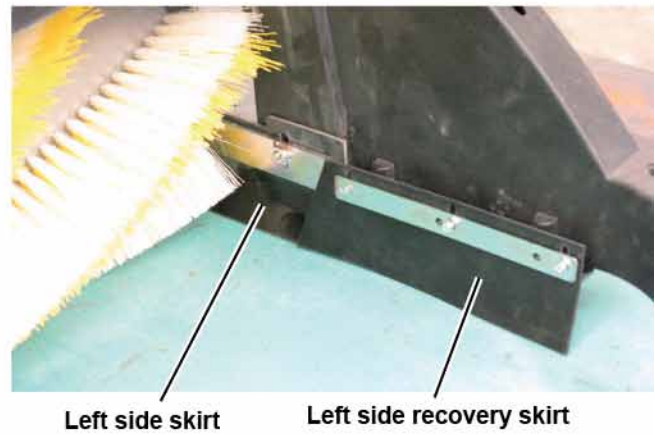
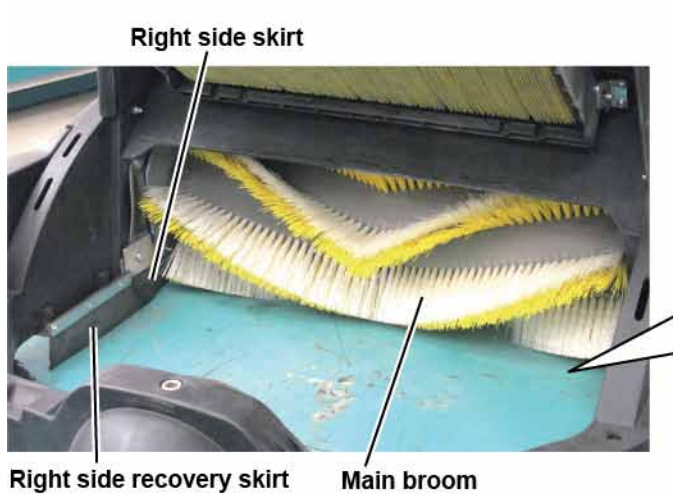

Maintenance and Adjustments

Main Broom Height Check and Adjustment



Note: Brooms with harder or softer bristles are available. This procedure is applicable to all types of brooms.



Note: The adjustment of the broom print on the floor must be performed periodically, also according to the consumption of the bristles.

Check

- Check the main broom height as shown below:
 - Drive the machine on a level floor.
 - Turn on the machine and keep it stationary, lower the main broom and turn it on for a few seconds, so that the broom leaves its print on the floor.
 - Lift the main broom, then move the machine and turn it off.
 - Check that the main broom print (A), along its length, is 2 to 4 cm wide.
 - If the print (A) is not within specifications, adjust the main broom height as shown below.

- Perform step 1 again to check the proper adjustment of the main broom distance from the floor.
- When the broom is too worn and can no longer be adjusted, replace it according to the procedure shown in the relevant paragraph.



Caution! If the main broom print is excessive (larger than 4 cm), the machine regular operation is affected and the moving parts or electrical components can overheat, thus reducing machine life. Pay careful attention when performing the main broom height check, and always use the machine according to the indicated conditions.

Adjustment

- Turn the knob (B) taking into account what follows (see also the descriptive plate (C)):
 - to increase the print width, turn the knob counter-clockwise
 - to decrease the print width, turn the knob clockwise

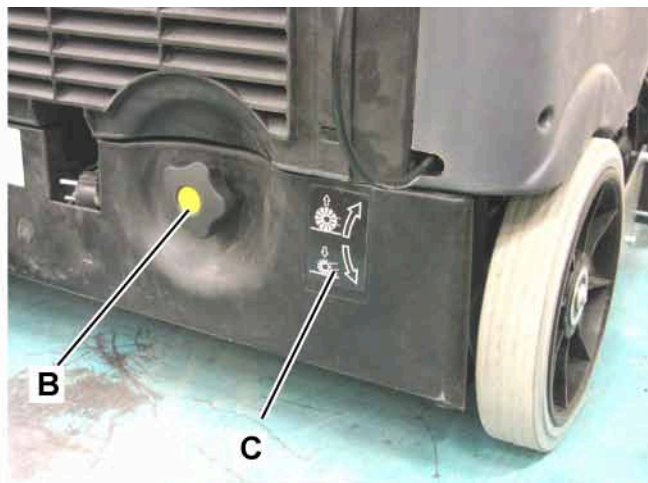
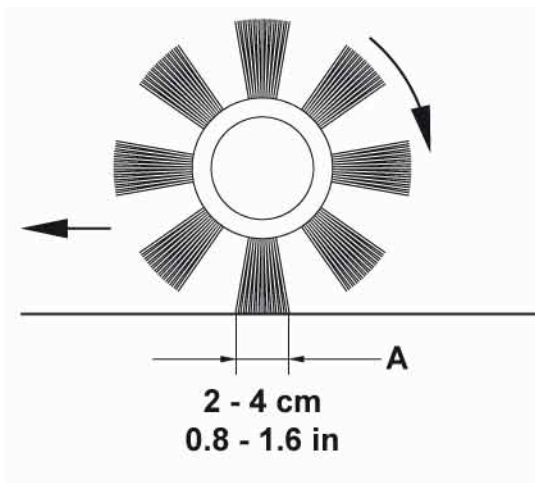

Skirt Height Check and Adjustment

Preliminary Operations

1. Empty the hopper (as shown in the User Manual).
2. Drive the machine on a level ground that is suitable for checking the skirt height. Make sure that the machine cannot move independently.
3. Turn the ignition key to “0”.
4. Remove the hopper by using its transport handle and wheels.

Right Side Skirt and Right Side Recovery Skirt Check

5. Unscrew the nuts (A) and remove the rear side cover (B).

6. Check the side skirt (C) and the recovery skirt (D) for integrity. Replace the skirts when they have cuts (E) larger than 20 mm or cracks/tears (F) larger than 10 mm (see the procedure in the relevant paragraph).
7. Check that the height (G) of the side skirt (C) and recovery skirt (D) is 0 - 3 mm. If necessary:
 - for the side skirt (C) loosen the nuts (H) and the inner screw (I), then adjust the position of side skirt (C). Then tighten the nuts (H) and the screw (I).
 - for the recovery skirt (D) loosen the screws (J), then adjust the position of the recovery skirt (D). Then tighten the screws (J).

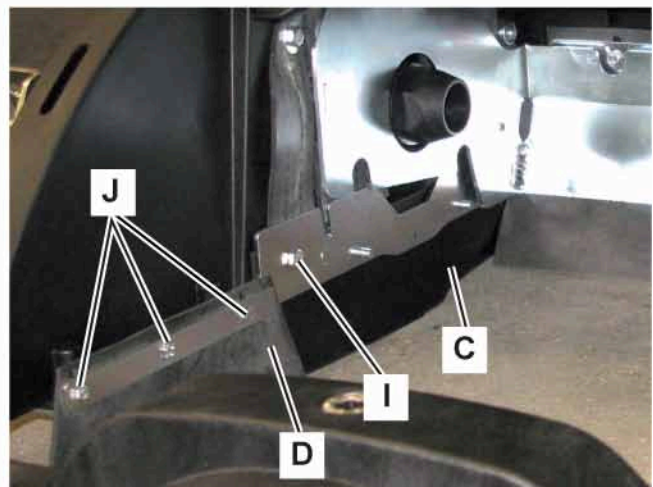
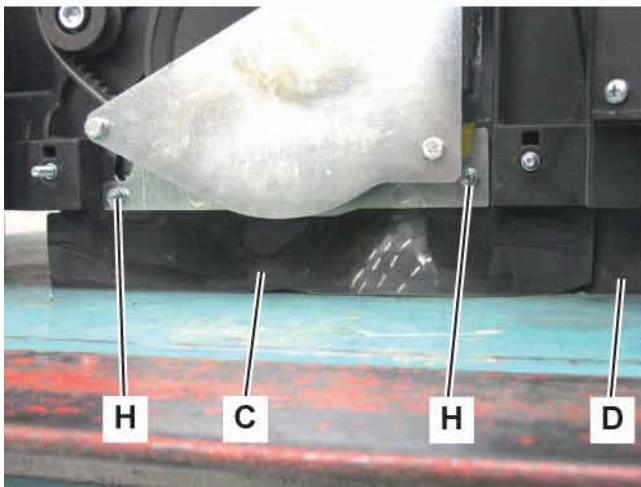
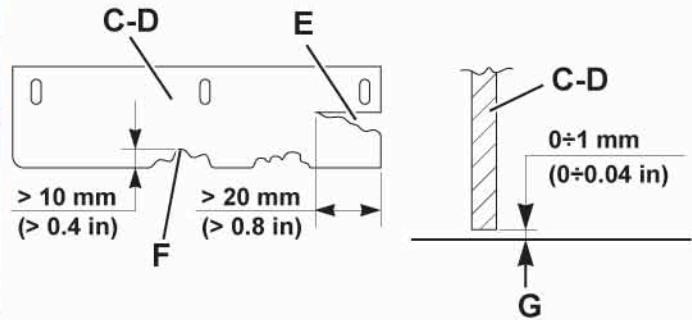
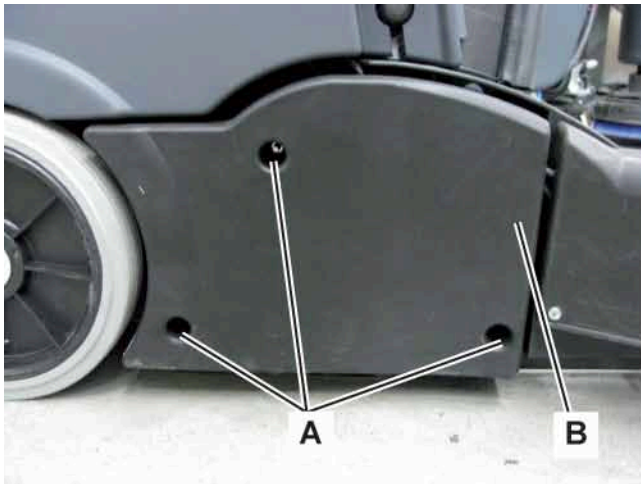

Skirt Height Check and Adjustment (Continues)

Left Side Skirt and Left Side Recovery Skirt Check

8. Lift the tab (A) and turn the knob (B) counter-clockwise, until it is disengaged, then open the left door (C).
9. Check the side skirt (D) and the recovery skirt (E) for integrity.

Replace the skirts when they have cuts (F) larger than 20 mm or cracks/tears (G) larger than 10 mm (see the procedure in the relevant paragraph).

10. Check that the height (H) of the side skirt (D) and recovery skirt (E) is 0 - 3 mm. If necessary:
 - For the side skirt (D) loosen the nuts (I) and the screws (J), then adjust the position of side skirt (D). Then tighten the nuts (I) and the screws (J).
 - For the recovery skirt (E) loosen the screws (K), then adjust the position of the recovery skirt (E). Then tighten the screws (K).

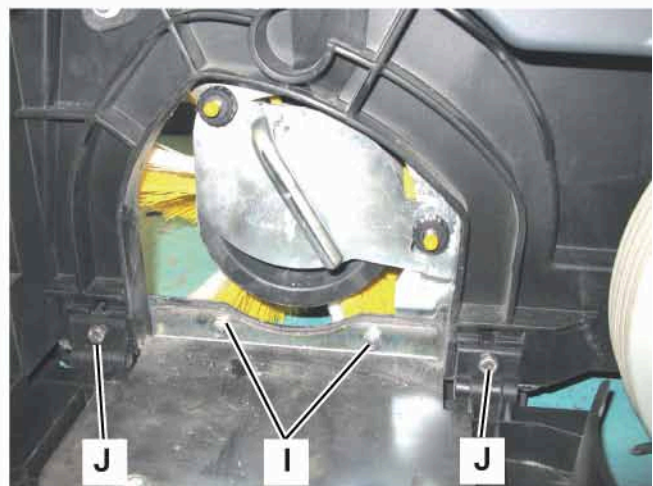
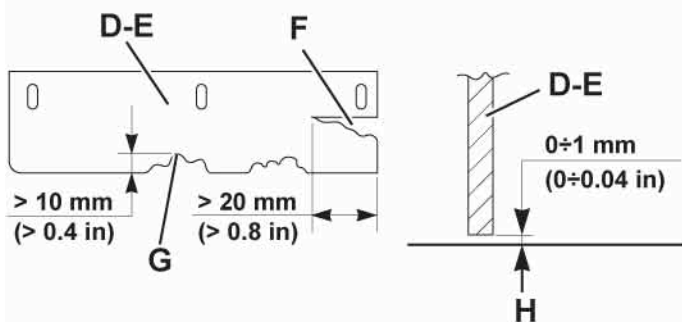
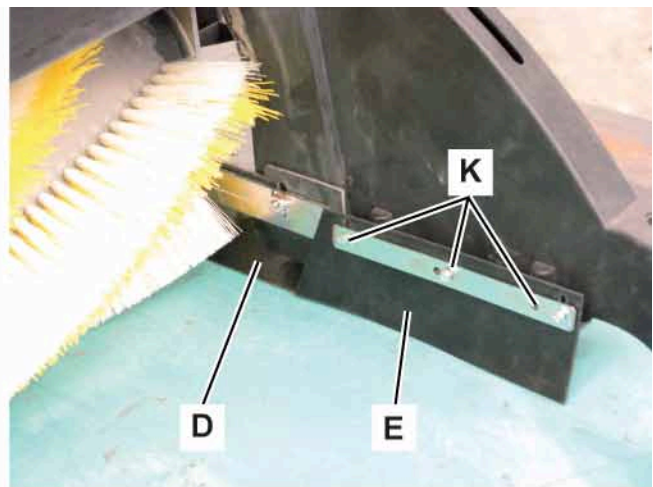
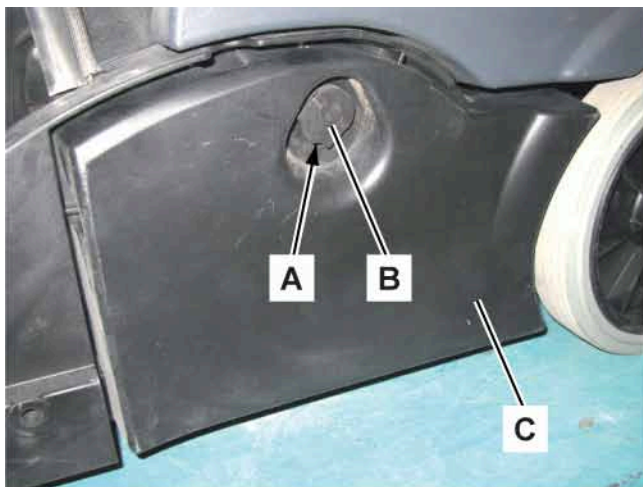

Skirt Height Check and Adjustment (Continues)

Front and Rear Skirt Check

11. Remove the main broom (see the procedure in the relevant paragraph).
12. On the hopper (F), check the front skirt (G) for integrity. Check the rear skirt (H) for integrity.

Replace the skirts when they have cuts (A) larger than 20 mm or cracks/tears (B) larger than 10 mm (see the procedure in the relevant paragraph).

13. Reinstall the hopper.
14. Check that the front skirt (I) and rear skirt (J) slightly rub the floor without being detached from it.
15. If necessary, adjust the rear skirt height, according to the following procedure:
 - Remove the hopper by using its transport handle and wheels.
 - Loosen the screws (K) and adjust the height of the rear skirt (H) by using the slots of the mounting holes.
 - After adjusting, tighten the screws (K).

If it is not possible to adjust the rear skirt properly, replace it (see the procedure in the relevant paragraph).

16. The front skirt cannot be adjusted; if necessary, replace it (see the procedure in the relevant paragraph).

Reassembly

17. Install the main broom (see the procedure in the relevant paragraph).
18. Install the hopper by using its transport handle and wheels.

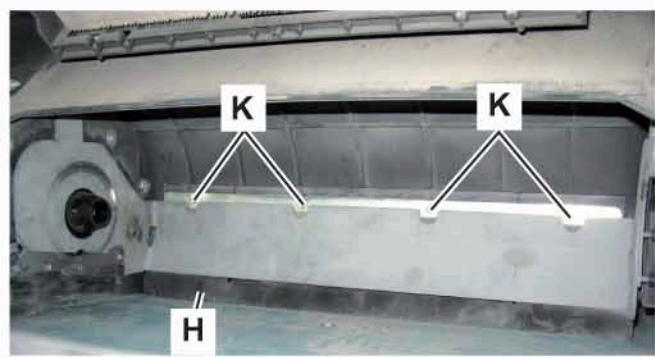
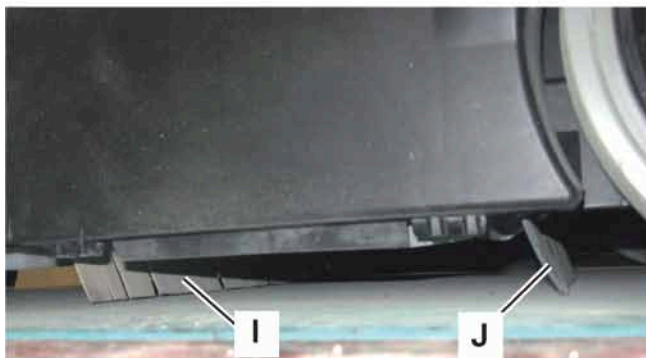
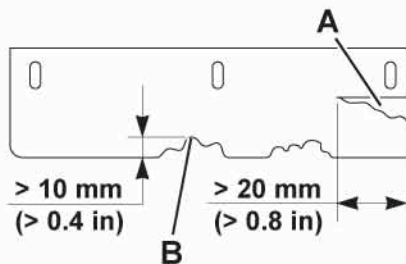

Troubleshooting

Trouble	Possible causes	Remedy
The machine collects little debris/dust.	The dust filter is clogged.	Clean the dust filter by using the filter shaker or by disassembling it.
	The hopper is full.	Empty the hopper.
	The skirts are not properly adjusted or are broken.	Adjust/replace the skirts.
	The brooms are not properly adjusted.	Adjust the broom height.
	The main broom belt is misadjusted or worn.	Adjust or replace the main broom belt.

Removal and Installation

Main Broom Removal/Installation



Note: *Brooms with harder or softer bristles are available. This procedure is applicable to all types of brooms.*



Warning! *It is advisable to wear protective gloves when replacing the main broom because there can be sharp debris between the bristles.*

2. Turn the ignition key to “0”.
3. Remove the hopper by using its transport handle and wheels.
4. Fully turn the main broom height adjusting knob (A) clockwise (by lifting it).
5. Lift the tab (B) and turn the knob (C) counter-clockwise until it is disengaged, then open the left door (D).

Disassembly

1. Drive the machine on a level floor and ensure that it cannot move.

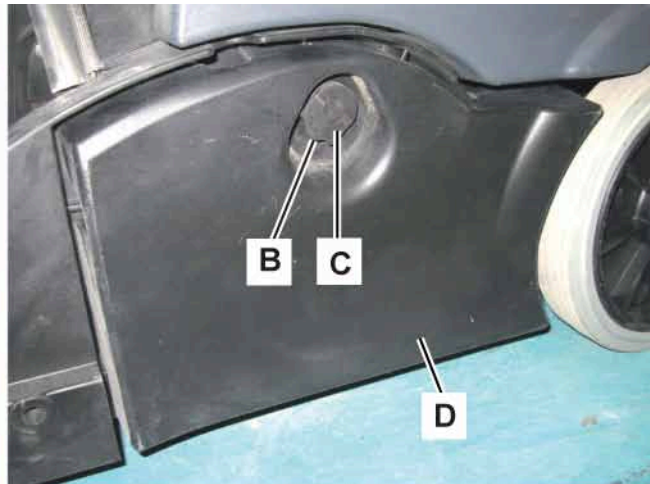
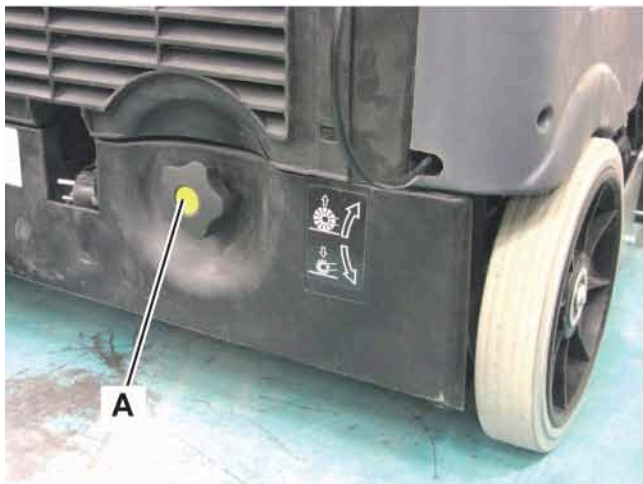

P200300

Main Broom Removal/Installation (Continues)

6. Loosen the handwheels (E); grasp the handle (K) and remove the main broom cover (F) by turning it slightly counter-clockwise to disengage it.
7. Remove the main broom (G) by pulling it out from the front side of the machine; slightly lift the front side of the machine to remove the main broom easily.
9. Install the main broom (G): The bristles (I) must be bent in the direction shown in the figure.
10. Install the main broom (G) by inserting it in the front side of the machine, by engaging its mesh (J) on hexagonal drive hub (H).
11. Install the main broom cover (F), then tighten the handwheels (E).

Assembly

8. Check that the main broom hexagonal drive hub (H) is free from dirt or foreign materials (ropes, rags, etc.) accidentally rolled up.

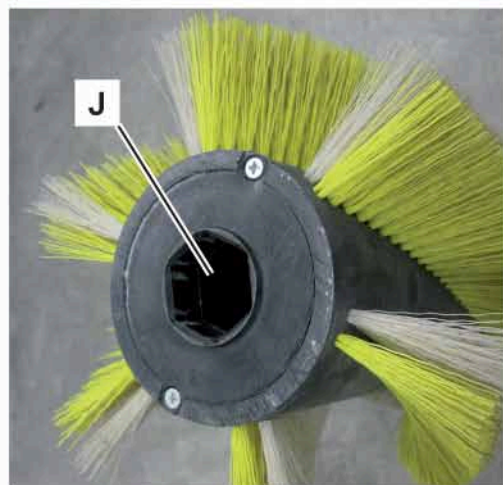
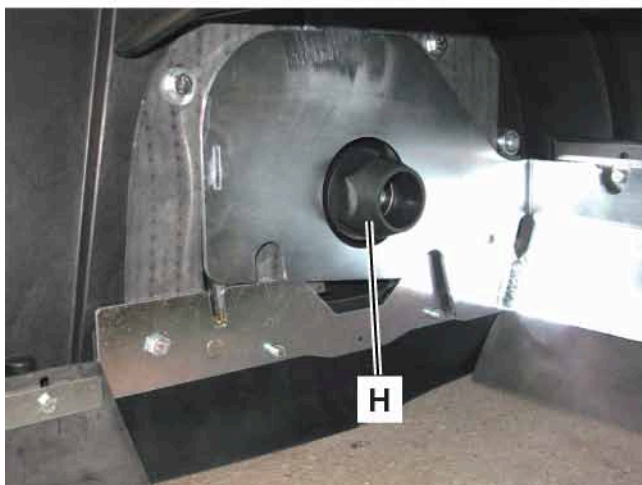
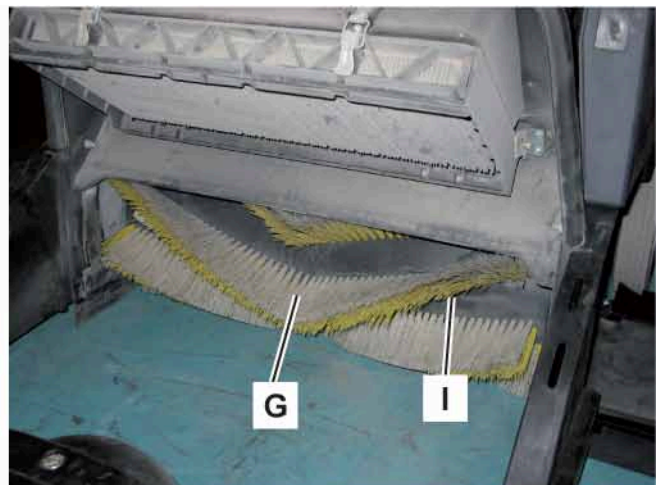
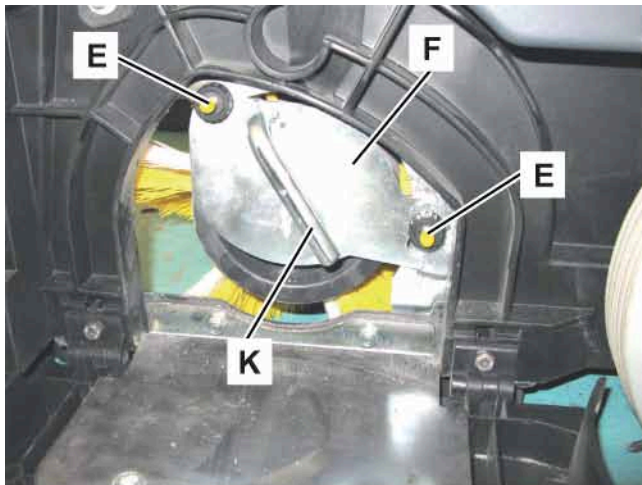

Main Broom Removal/Installation (Continues)

12. Lift and close the left door (D) and fasten it with the knob (C); lower the tab (B) in its housing.
13. Reinstall the hopper.
14. Adjust the main broom height (see the procedure in the relevant paragraph).

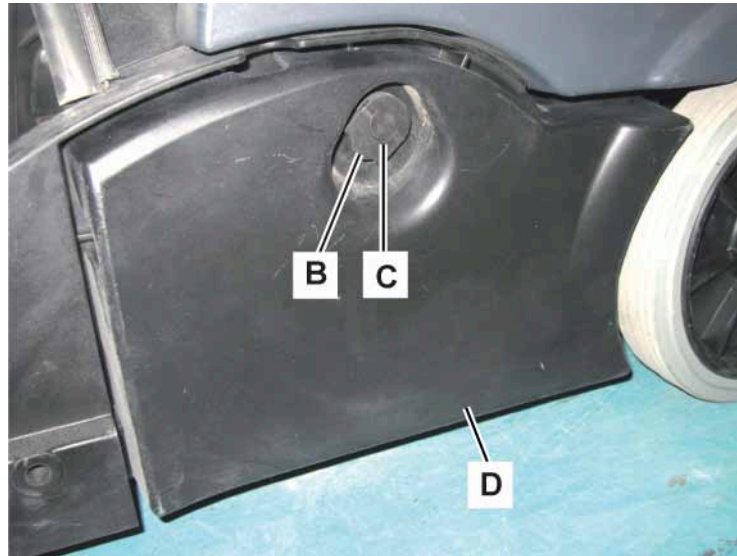

P200302

Main Broom Belt Check/Replacement

Check

1. Drive the machine on a level floor and ensure that it cannot move.
2. Turn the ignition key to “0”.
3. Remove the hopper by using its transport handle and wheels.
4. Disengage the front fastener and open the battery/engine compartment hood.
5. Remove the screws (A) and the right side panel (B) from the machine.
6. Remove the nuts (C) and the right cover (D).

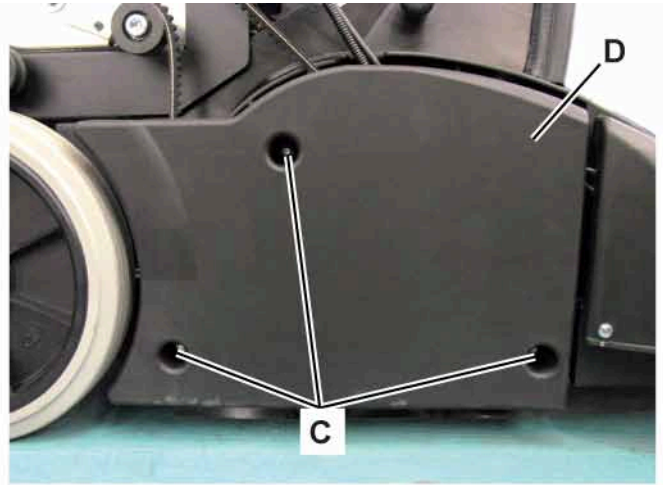
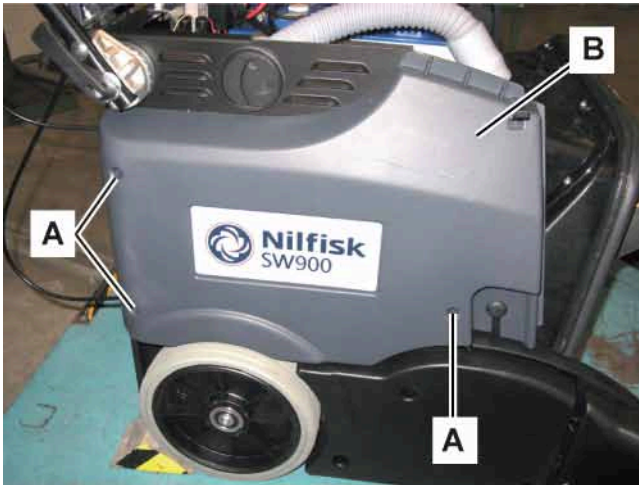

P200303

Main Broom Removal/Installation (Continues)

7. Visually inspect the entire length of the main broom belt (E) to make sure it is intact and shows no signs of cuts, tears or cracks. If necessary, replace the belt.
8. Check that the flexible tensioner (F) is working and that the belt is properly tightened. Check that the rotation pulleys of the belt (E) rotate freely and are free from dirt and foreign materials (ropes clothes, etc.) accidentally rolled up on their rotation shafts.
10. Remove the fastening screws (I) of the plate (J).
11. Move the plate (J) with the pulley (K) by disengaging the hexagonal drive hub (L) from the socket (M) of the main broom.
12. Retrieve the belt (E) by disconnecting it from the pulley (K).
13. Install the new belt by performing the steps 9. to 12. in the reverse order.

Replacement

9. Disengage the flexible tensioner (F) from the belt (E), then release the belt from the pulleys (G) and (H).

Reassembly

14. Perform steps 3. to 6. in the reverse order.

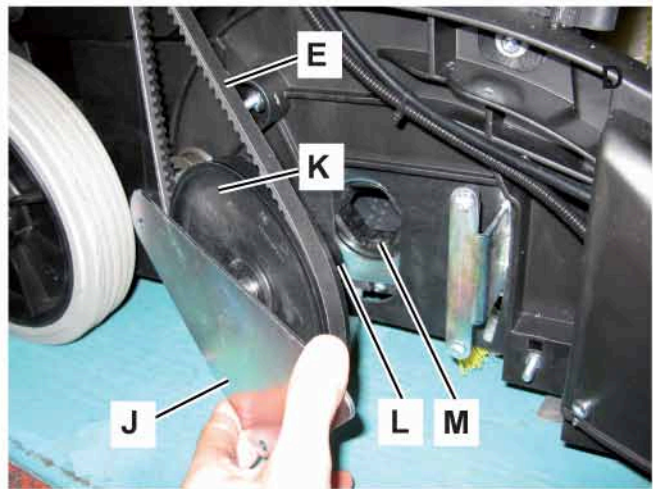
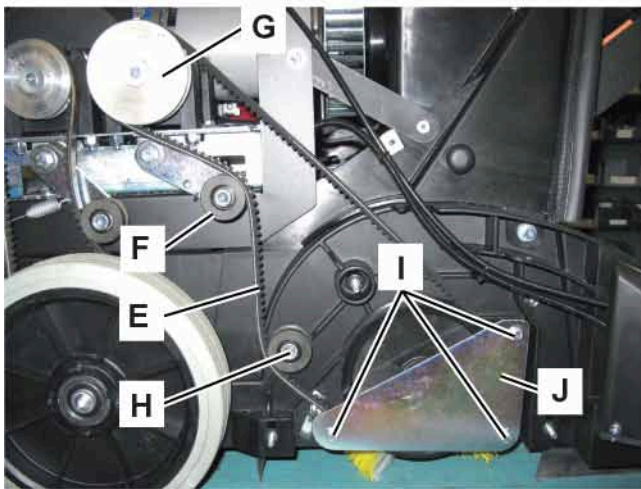

P200304

Main Broom Pulley and Hexagonal Drive Hub Replacement

Disassembly

1. Remove the main broom belt (see the procedure in the previous paragraph).
2. At the workbench, remove the snap ring (A) and remove the bearing (D) and the hexagonal drive hub with pulley (B) from the mounting plate (C).

Assembly

3. Assemble the hexagonal drive hub with pulley in the reverse order of disassembly.

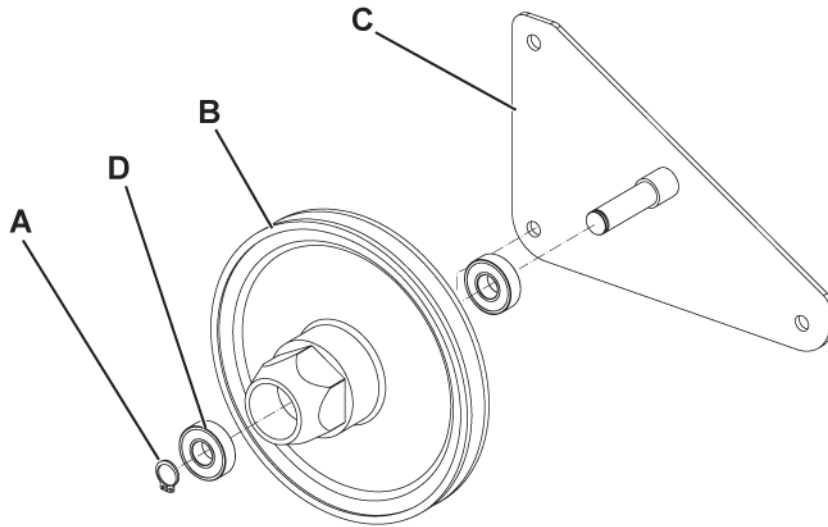

P200305

Skirt Removal/Installation

Right side skirt disassembly/assembly

1. Drive the machine on a level ground that is suitable for checking the skirt height. Make sure that the machine cannot move independently.
2. Turn the ignition key to “0”.
3. Remove the hopper by using its transport handle and wheels.
4. Unscrew the nuts (A) and remove the rear side cover (B).
5. Remove the screws (C) and release the flange (D).
6. Remove the nuts (E) and loosen the inner screw (F).
7. Remove the right side skirt (G).
8. Install the right side skirt by performing the steps 3. to 7. in the reverse order.
9. Check the right side skirt height (see the procedure in the relevant paragraph).

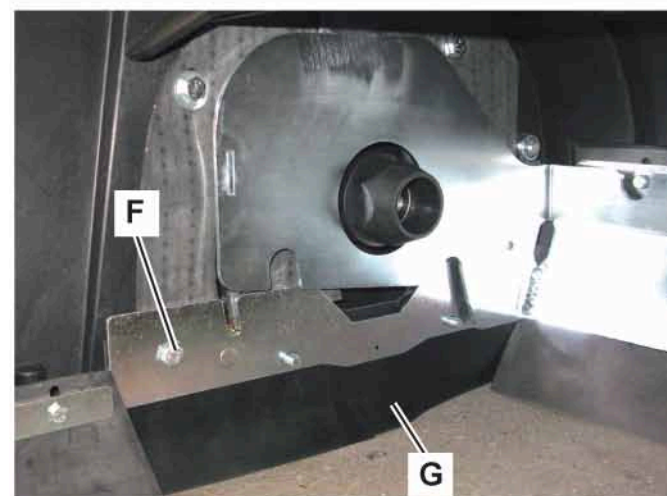
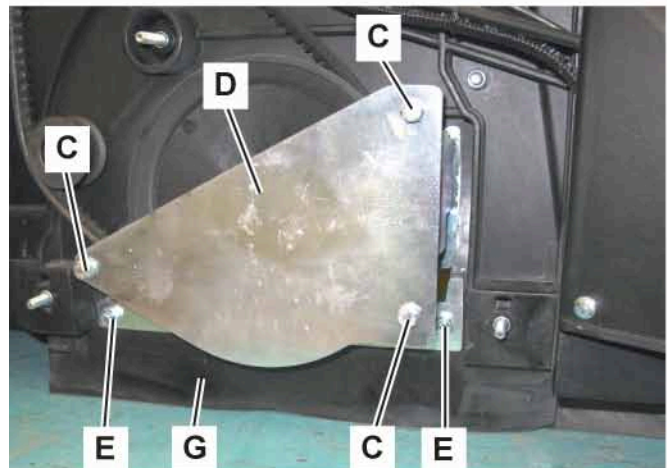
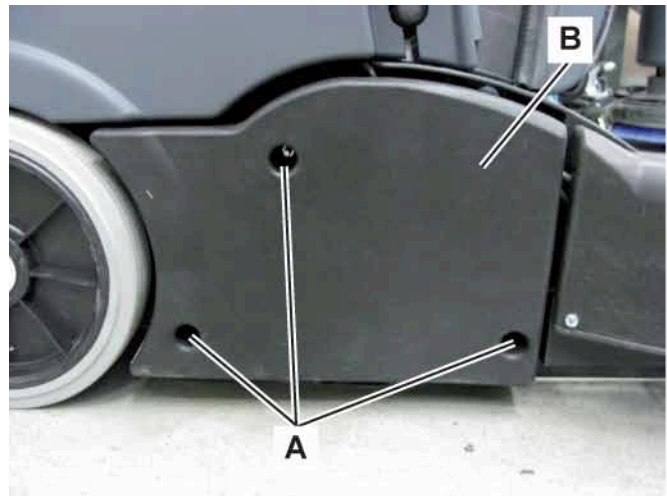

Skirt Removal/Installation (Continues)

Left side skirt disassembly/assembly

1. Drive the machine on a level ground that is suitable for checking the skirt height. Make sure that the machine cannot move independently.
2. Turn the ignition key to “0”.
3. Lift the tab (H) and turn the knob (I) counter-clockwise until it is disengaged, then open the left door (J).
4. Remove the screws (K) and the door (L).
5. Remove the screws (M) and remove the left side skirt with bracket.
6. Install the left side skirt by performing the steps 3. to 5. in the reverse order.
7. Check the left side skirt height (see the procedure in the relevant paragraph).

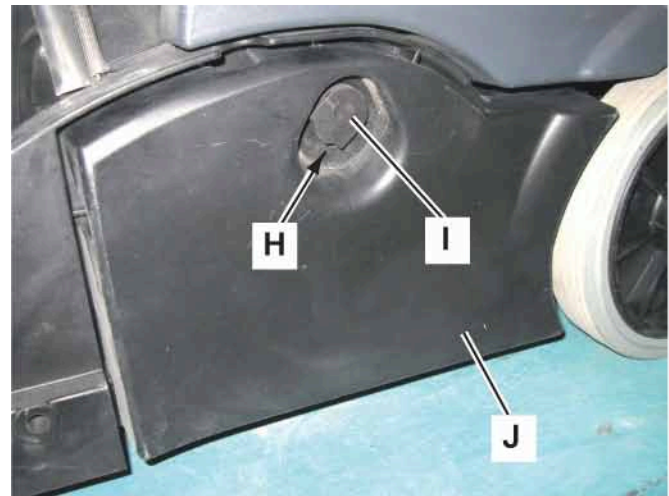

Right and Left Side Recovery Skirt Disassembly/Assembly

1. Drive the machine on a level ground that is suitable for checking the skirt height. Make sure that the machine cannot move independently.
2. Turn the ignition key to “0”.
3. Remove the hopper by using its transport handle and wheels.
4. Remove the screws (N) and remove the left or right side recovery skirt (O).
5. Install the left side skirt by performing the steps 3. and 4. in the reverse order.
6. Check the recovery skirt height (see the procedure in the relevant paragraph).

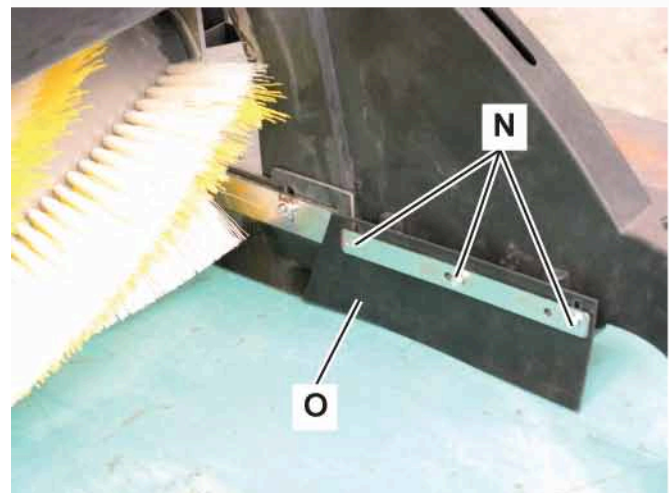
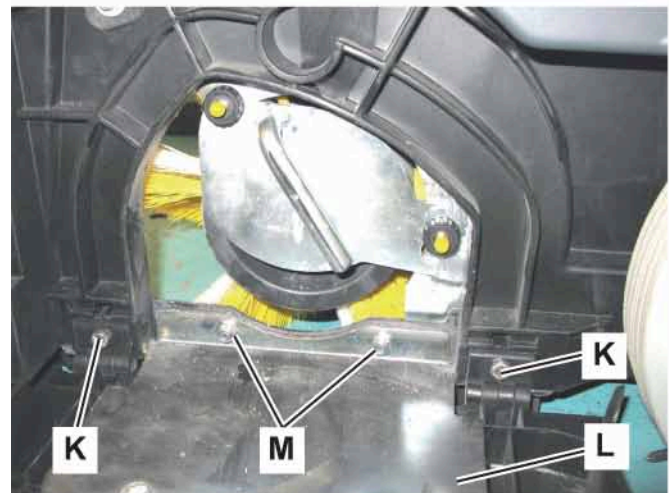

Skirt Removal/Installation (Continues)

Front skirt disassembly/assembly

1. Empty the hopper (as shown in the User Manual).
2. Drive the machine on a level ground that is suitable for checking the skirt height, after assembling it. Make sure that the machine cannot move independently.
3. Turn the ignition key to “0”.
4. Remove the hopper by using its transport handle and wheels.
5. On the hopper (A), remove the screws with the nut (B) and remove the metal strap and the front skirt (C).
6. Install the front skirt by performing the steps 3. to 5. in the reverse order.
7. Check the front skirt height (see the procedure in the relevant paragraph).

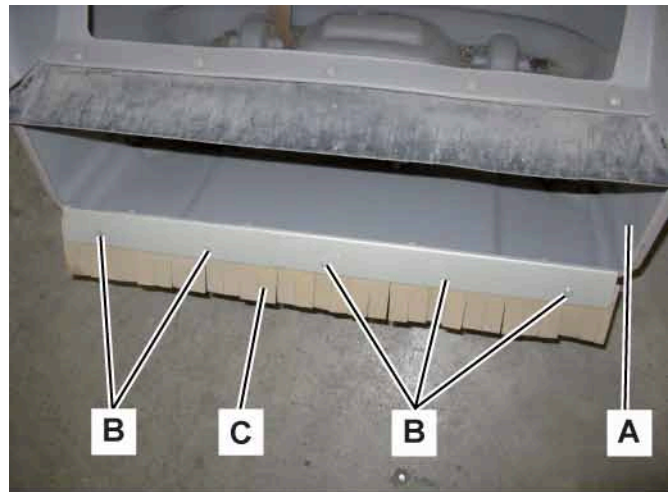

Rear Skirt Disassembly/Assembly

1. Remove the main broom (see the procedure in the relevant paragraph).
2. Fully turn the main broom height adjusting knob (C) counter-clockwise (by lifting it).
3. In the main broom compartment, remove the screws (D), then remove the metal strap (E) and the rear skirt (F).
4. Install the rear skirt (F) by performing step 3. in the reverse order.
5. Adjust the height of the rear skirt (F) (see the procedure in the relevant paragraph).
6. Fully turn the main broom height adjusting knob (C) clockwise (by lifting it).
7. Install the main broom (see the procedure in the relevant paragraph).

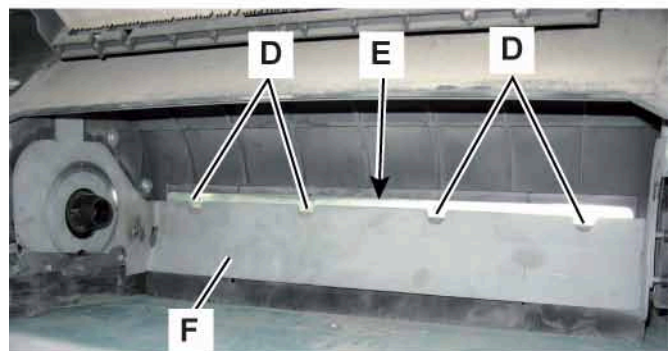
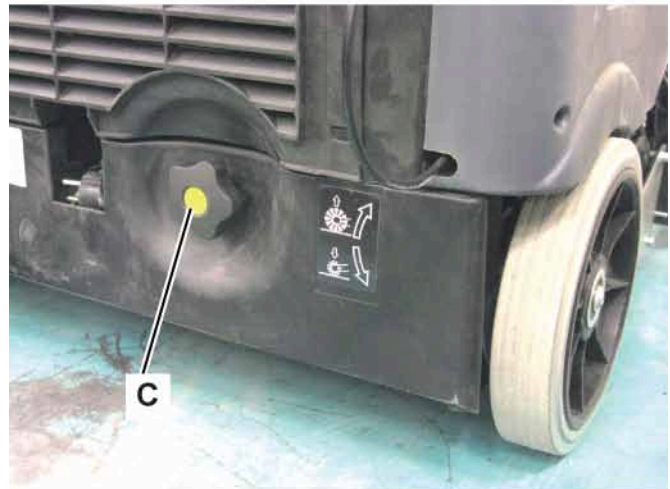

Specifications

Model		Advance / Nilfisk SW900 B	Nilfisk SW900 P
Main broom size (length x diameter)		23.6 x 10.4 in (600 x 265 mm)	
Main broom	speed	420 rpm	

Side Broom System

Functional Description

The right/left lever on the handle determines the descent of right/left side broom which is released by a metal cable connected to its support plate.

The broom is fastened to the reduction unit shaft with an axial threaded knob.

Battery Version

The electromagnetic switch (K0) directly drives the main motor (M0) and the side broom motors (M2) and (M3*), while the relay (K1*) turns on the filter shaker motor (M1).

On the circuit of the side broom motors (M2) and (M3*) there are microswitches (SW2) and (SW3*) respectively, which deactivate the relevant motors when the brooms are lifted from the ground by means of the manual levers on the handlebar.

The side broom motors (M2) and (M3*) are protected by 5A circuit breakers (FB) and (FC*) respectively.

Petrol Version

The dynamotor (G) provides the current necessary for the activation of the side broom motors (M2) and (M3*).

When the engine is turned on, the current generated by the dynamotor (G) directly activates the side broom motors (M2) and (M3*).

On the circuit of the side broom motors (M2) and (M3*) there are microswitches (SW2) and (SW3*) respectively, which deactivate the relevant motors when the brooms are lifted from the ground by means of the manual levers on the handlebar.

The side broom motors (M2) and (M3*) are protected by 5A circuit breakers (FB) and (FC*) respectively.

* : when the left broom is equipped

Wiring Diagram (SW900 B)

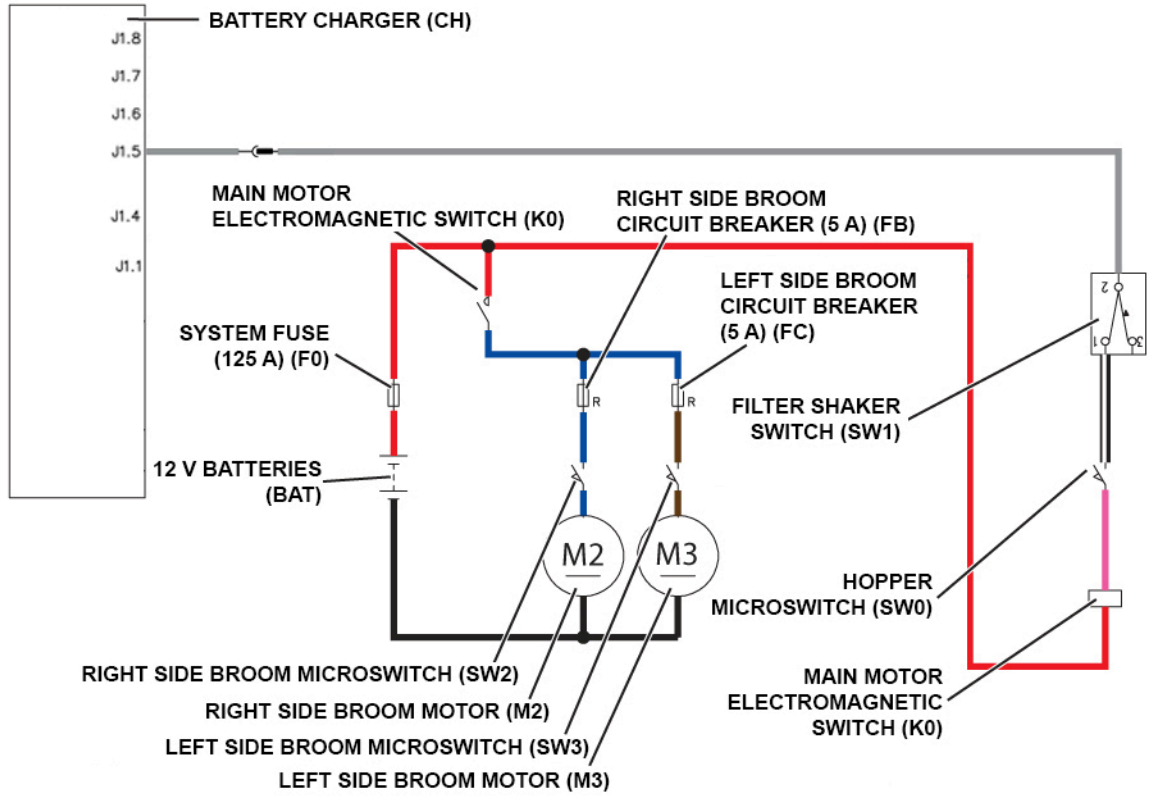

P200343

Wiring Diagram (SW900 P)

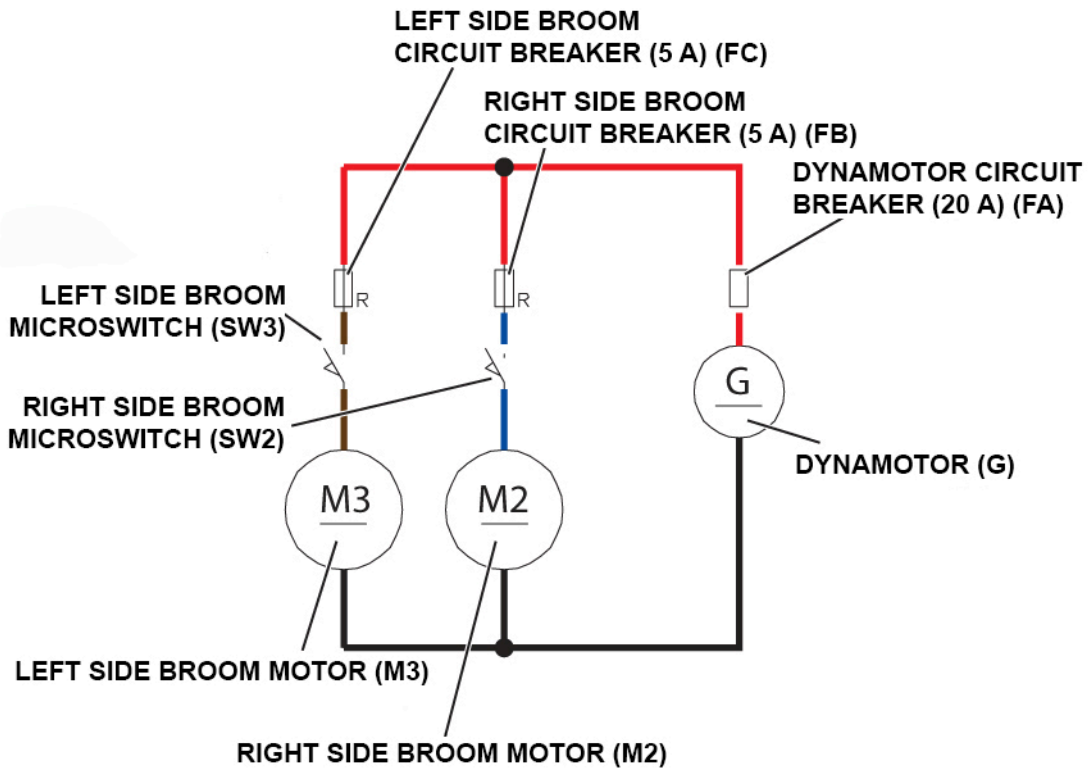

P200344

Component Locations

- Right side broom motor (M2)
- Left side broom motor (M3)
- Right side broom
- Left side broom
- Right side broom microswitch (SW2)
- Left side broom microswitch (SW3)
- Right side broom lifting/lowering and height adjusting lever
- Left side broom lifting/lowering and height adjusting lever
- Right side broom flexible control cable
- Left side broom flexible control cable

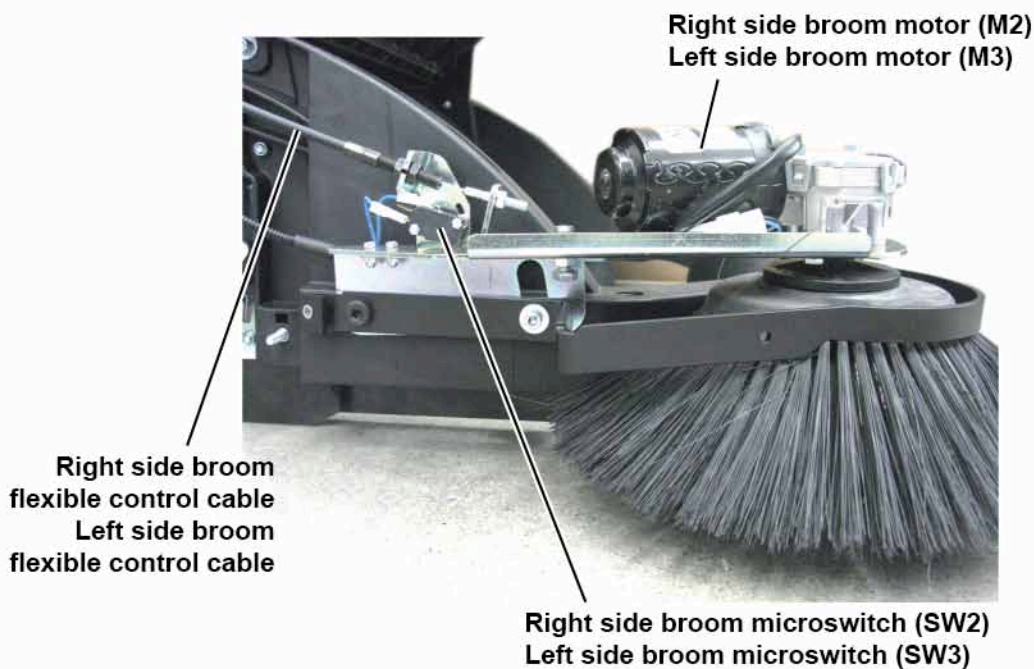

Maintenance and Adjustments

Side Broom Height Check and Adjustment



Note: Brooms with harder or softer bristles are available. This procedure is applicable to all types of brooms.



Note: This procedure refers to the right side broom height adjustment; the procedure for the left side broom is the same.

1. Drive the machine on a level floor.
2. Turn the ignition key to “I”.
3. Keep the machine stationary and activate the side broom lowering control lever; in this position run the side broom for a few seconds.
4. Lift and stop the side broom, then move the machine and turn it off.
5. Check the side broom print. The print is correct when the bristles touch the floor along a circle arc (A) as shown in the figure.
6. If necessary, adjust the height of the side broom, by using the mechanical end-of-stroke (B) after loosening the locknut (C); when the adjustment is completed, tighten the locknut (C).
7. When the broom is too worn to be adjusted, replace it (see the procedure in the relevant paragraph).
8. Turn the ignition key to “0”.



Warning! *If the side broom print is excessive, the machine regular operation is affected and the moving parts or electrical components can overheat, thus reducing machine life. Pay careful attention when performing the side broom height check, and always use the machine according to the indicated conditions.*

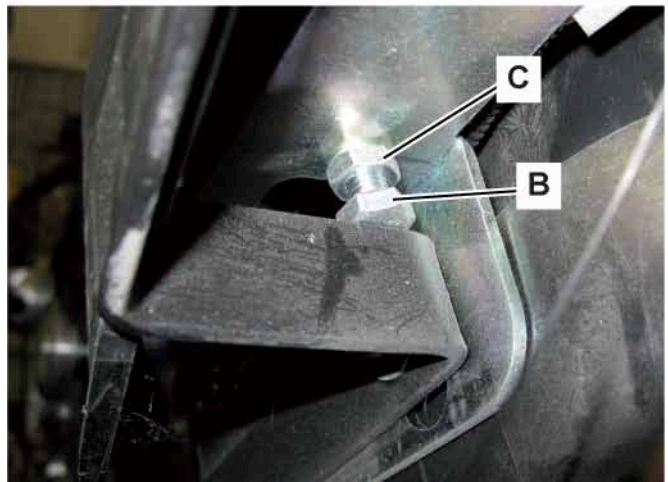
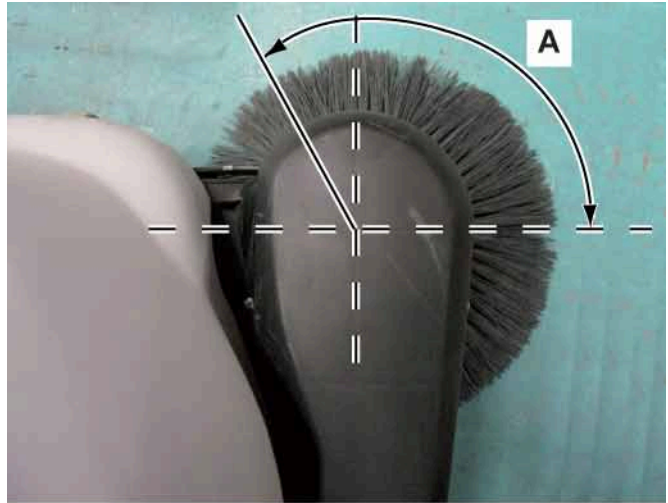

Troubleshooting

Trouble	Possible causes	Remedy
The side broom does not operate.	The circuit breaker (FB) or (FC) (optional) is open.	Wait for the side broom motor to cool down, then reset the fuse by pressing the relevant push-button.
	The main fuse (FA) is open.	Replace the main fuse.
	The side broom microswitch is faulty or misadjusted.	Replace the relevant side broom microswitch or adjust it.

Removal and Installation

Side Broom Disassembly/Assembly



Note: *Brooms with harder or softer bristles are available. This procedure is applicable to all types of brooms.*



Warning! *It is advisable to wear protective gloves when replacing the side broom because there can be sharp debris between the bristles.*



Note: *This procedure refers to the right side broom removal; the procedure for the left side broom is the same.*

Disassembly

1. Drive the machine on a level floor and ensure that it cannot move.
2. Lift the side broom until the end of stroke by using the lever.
3. Turn the ignition key to “0”.
4. Loosen the knob (A) inside the side broom, then remove the side broom (B) by disengaging it from the three positioning pins (C).

Assembly

5. To install the side broom easily, use its lifting lever by turning it to fully lowered position.
6. Install the side broom in its housing and engage it on its three positioning pins (C), then tighten the knob (A).
7. If necessary, check the side broom height (see the procedure in the relevant paragraph).

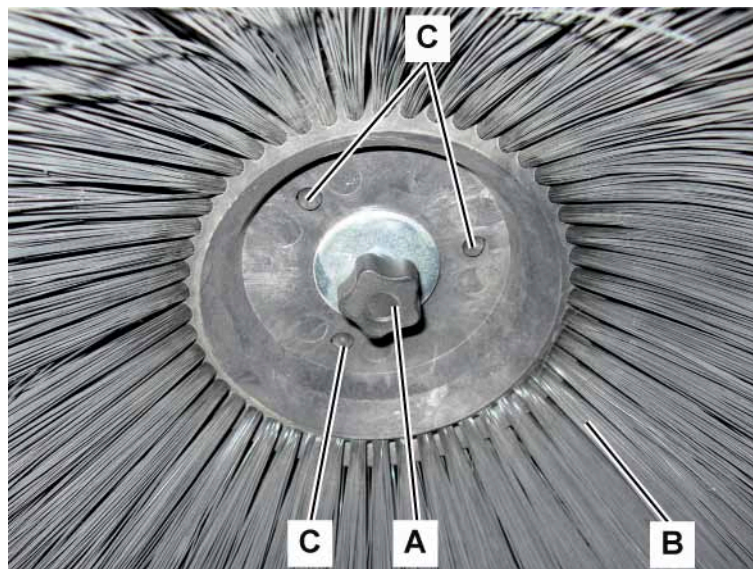

Side Broom Motor Amperage Check



Warning! *This procedure must be performed by qualified personnel only.*



Note: *This procedure refers to the right side broom check; the procedure for the left side broom is the same.*

1. Remove the side broom of the motor to be check (see the procedure in the relevant paragraph).
 2. Remove the hopper by using its transport handle and wheels.
 3. Disengage the front fastener and open the battery/engine compartment hood.
 4. On the right rear side of the battery/engine compartment, apply the amp clamp on a cable (A) of the side broom motor to be checked.
 5. (For SW900 B) Turn the ignition key to “I”. (For SW900 P) Turn the ignition key to “I” and start the petrol engine (as shown in the User Manual); wait a few minutes that the engine reaches the target speed.
 6. With the lever, lower and activate the side broom to be checked, and then check that the motor amperage is between 1 and 3A at 24V.
 7. Lift the side broom and stop its rotation.
 8. Turn the ignition key to “0”.
 9. Remove the amp clamp.
 10. If the amperage is higher, perform the following procedures to detect and correct it:
 - Check if there is dust or dirt (cords, cables, etc.) on the side broom hub.
 - Disassemble the motor (see the procedure in the relevant paragraph), and check the condition of all its components.
- If the above-mentioned procedures do not lead to a correct amperage, the motor must be replaced (see the procedure in the relevant paragraph).

Reassembly

11. Perform steps 1. to 3. in the reverse order.

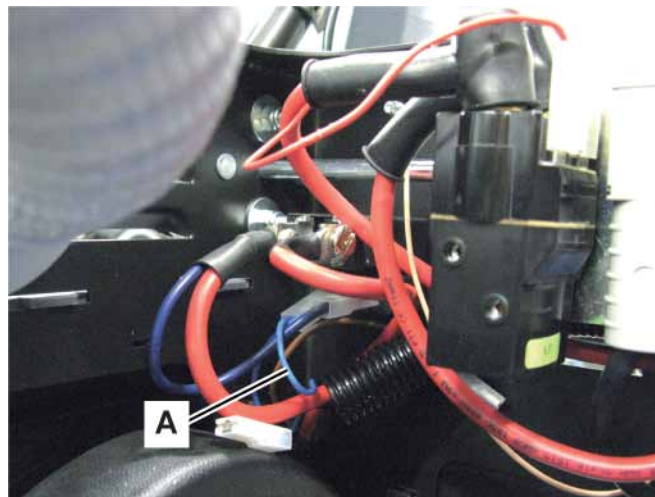

Side Broom Reduction Unit Removal/Installation



Note: *This procedure refers to the right side reduction unit; the procedure for the left side reduction unit is the same.*

Disassembly

1. Remove the side broom (see the procedure in the relevant paragraph).
2. Remove the screws (A) and the nut (B), then remove the side broom reduction unit guard (C).
3. Unscrew the dowel (D) and remove the broom hub (E).

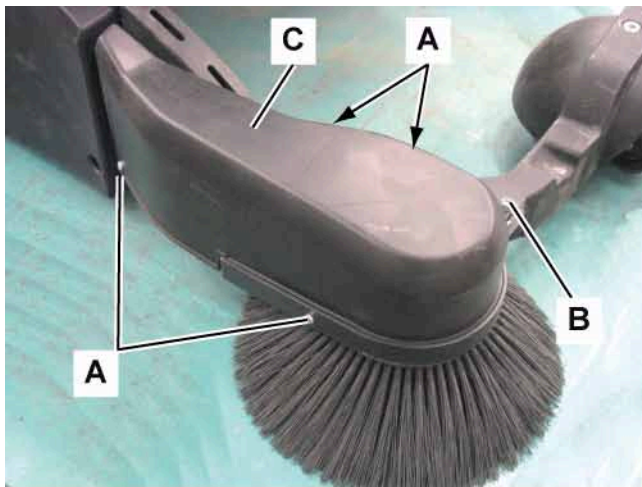

4. Remove the mounting screws (F) of the side broom reduction unit (G).
5. Cut the clamp (H).
6. Disconnect the electrical connector (I) and remove the reduction unit (J) of the side broom.

Assembly

7. Assemble the reduction unit in the reverse order of disassembly.

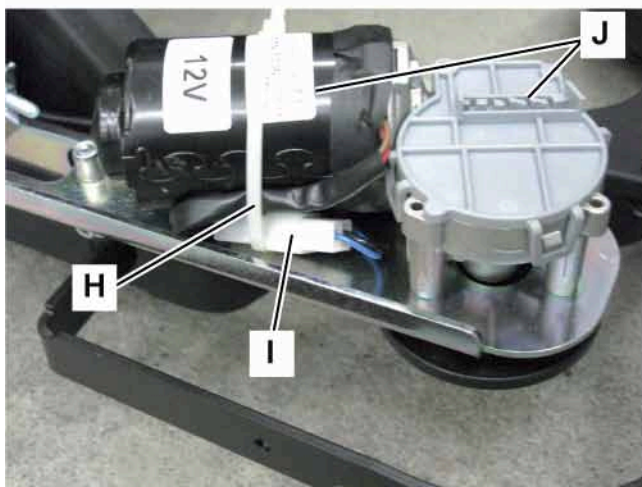
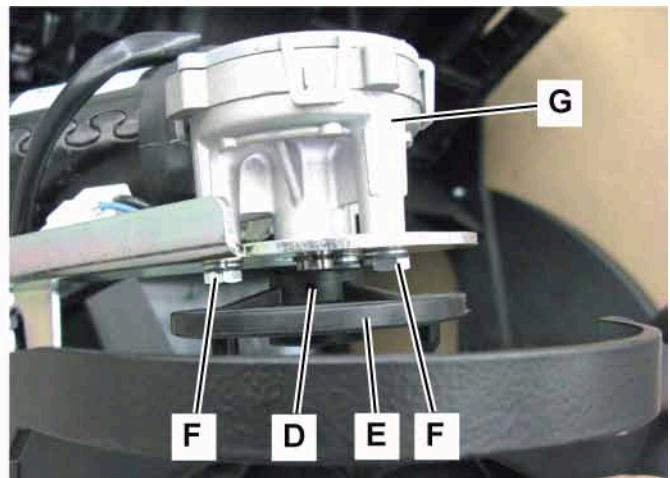

Right Side Broom Control Cable Removal/Installation



Note: *This procedure refers to the right side reduction unit; the procedure for the left side reduction unit is the same.*

Disassembly

1. Drive the machine on a level floor and ensure that it cannot move.
2. Turn the ignition key to “0”.
3. Remove the hopper by using its transport handle and wheels.
4. Disengage the front fastener and open the battery/engine compartment hood.
5. Remove the screws (A) and the side panel (B).
6. (Right side) Remove the nuts (C) and the right cover (D).
(Left side) Lift the tab (E) and turn the knob (F) counter-clockwise until it is disengaged, then open the left door (G).
7. Remove the screws (H) and the nut (I), then remove the side broom reduction unit guard (J).

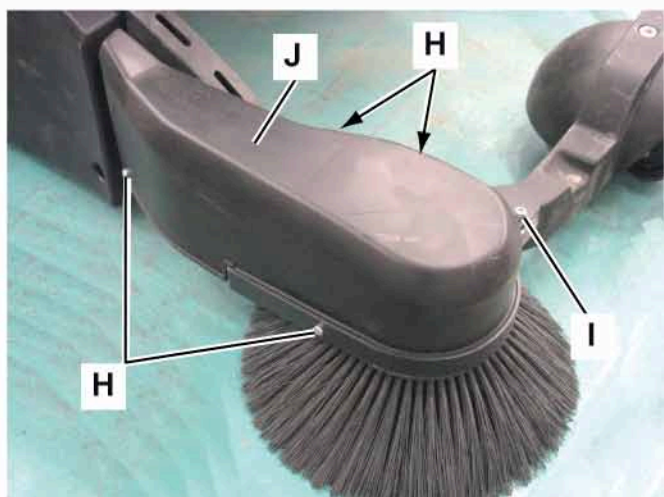
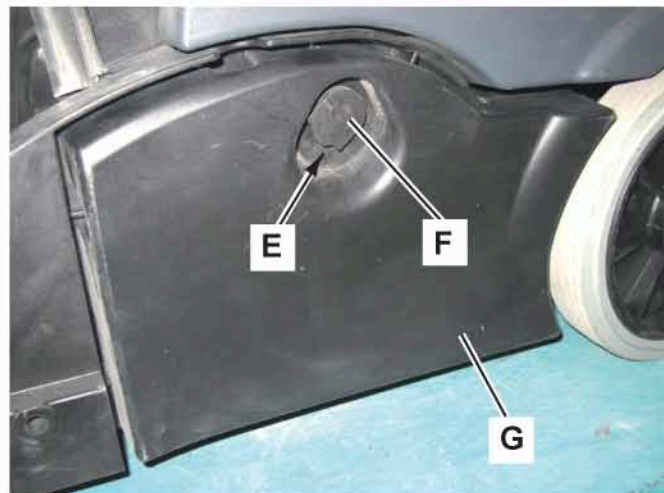
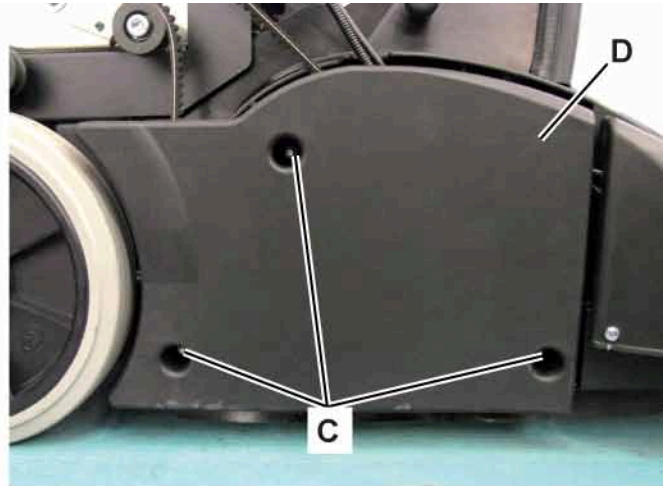

Right Side Broom Control Cable Removal/Installation (Continues)

8. Remove the screw (K) of the cable front terminal.
9. Loosen the nut (L).
10. Disengage the cable (M) from the slot (N).
11. Cut the clamps (P) retaining the cable (O).
12. Unscrew the nut (Q) and remove the lever (R) with the cable.

Assembly

13. Assemble the cable in the reverse order of disassembly, and note the following:
 - After installation, perform the adjustment of the cable (M) (see the procedure for adjusting the side broom microswitch).

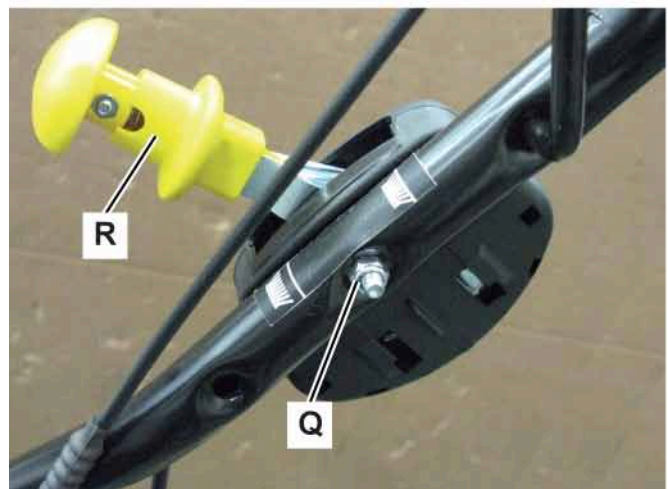
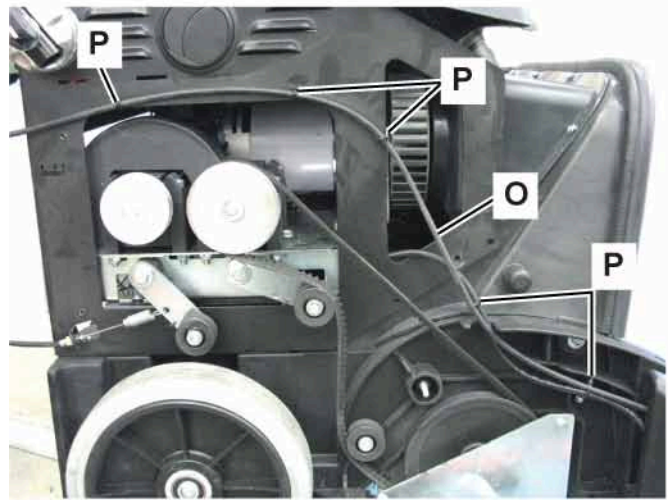
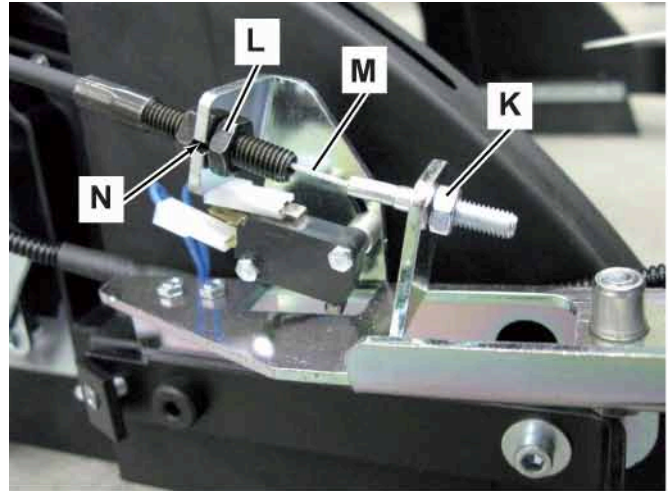

Side Broom Microswitch Adjustment and Removal/Installation



Note: *This procedure refers to the right side reduction unit; the procedure for the left side reduction unit is the same.*

Adjustment

1. Drive the machine on a level floor and ensure that it cannot move.
2. Turn the ignition key to “0”.

3. Remove the hopper by using its transport handle and wheels.
4. Disengage the front fastener and open the battery/engine compartment hood.
5. (For SW900 B) Disconnect the battery connector.
6. Remove the screws (A) and the nut (B), then remove the side broom motor guard (C).

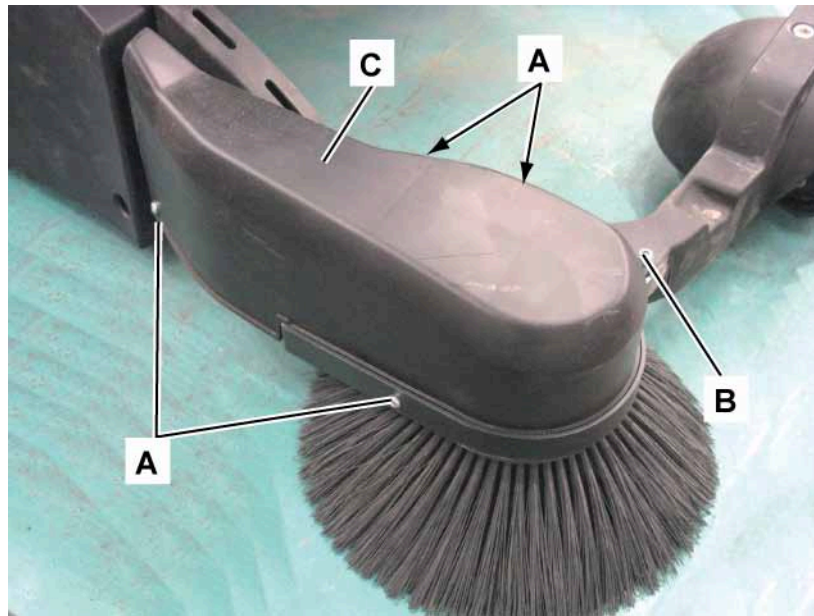

Side Broom Microswitch Adjustment and Removal/Installation (Continues)

- Lift the side broom until the end of stroke by using the lever. In this condition check that the side broom supporting arm (D) is lifted up to the end of stroke: The bottom of the slot (E) must be flush with the sliding pin (F).

If necessary, adjust the end-of-stroke with the nut and locknut (G) of the control cable (L).

- In the condition indicated by the previous step, loosen the screws with the nut (H) and lower the microswitch (I) until its terminal (J) on the vane (L) is activated; the terminal (J) must also slightly bend the vane (L) downwards. In this condition tighten the screws with the nut (H) of the microswitch.

Disassembly

- If necessary, disconnect the electrical connections (K), remove the screws with the nut (H), and then remove the microswitch (I).

Assembly

- Install the microswitch (I) and connect the electrical connections (K) then loosely install the screws with the nut (H).
- Adjust the microswitch (I) as shown in the previous steps 7. and 8.
- Perform steps 3. to 6. in the reverse order.

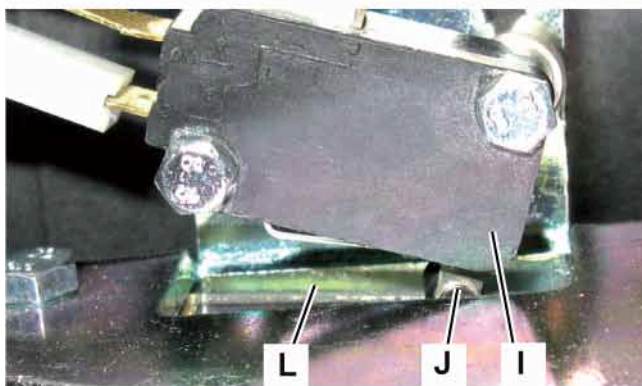
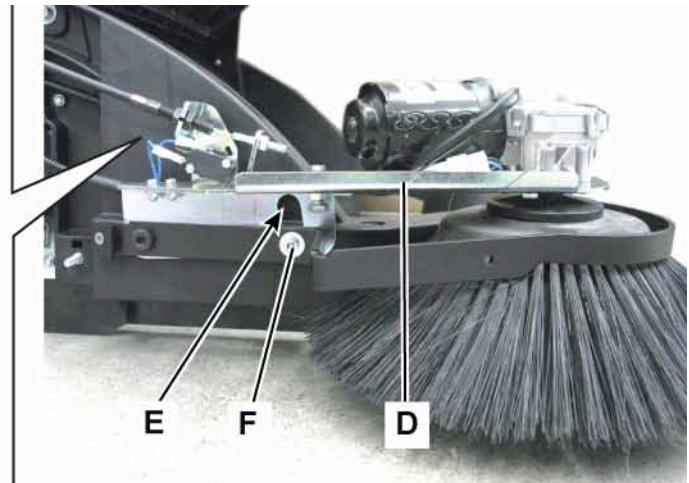
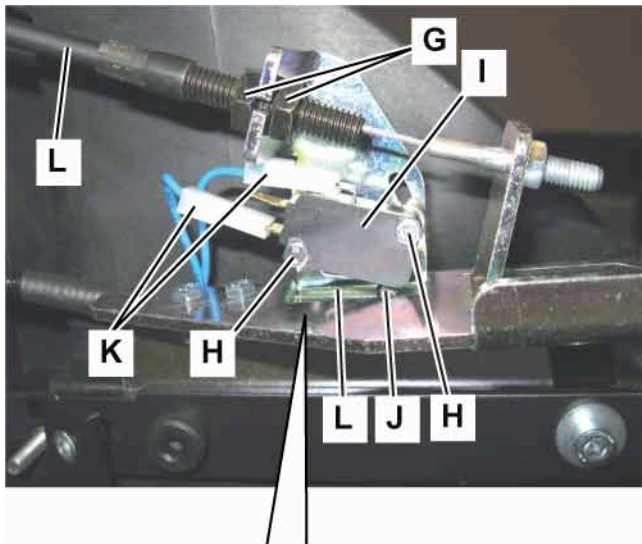

Specifications

Model		Advance / Nilfisk SW900 B	Nilfisk SW900 P
Cleaning width	with one side broom	32.5 in (825 mm)	
	with two side brooms	41.3 in (1,050 mm)	
Side broom diameter		12.4 in (315 mm)	
Theoretical working capacity	with one side broom	35,520 ft ² /h (3,300 m ² /h)	
	with two side brooms	45,208 ft ² /h (4,200 m ² /h)	
Side broom	motor power	0.05 hp (40 W)	
	speed	100 rpm	

Wheel System, Traction

Functional Description

At machine startup, the drive system is not engaged. The drive belt is not and tensioned between the two pulleys.

The lever on the center part of the handle, activates an idler pulley which tightens the belt which transmits the motion to the right rear wheel on which the driven pulley is installed.

The rear wheels are equipped with a particular system which allows for the rotation only in one direction. There is therefore a right wheel (marked with a colored sticker) and a left wheel.

The wheels are axially fastened on the propeller shaft by a screw.

Component Locations

- Drive control lever
- Drive system control flexible cable
- Drive belt
- Pulley
- Drive wheels



Maintenance and Adjustments

Drive system control cable, check/adjustment Check

1. (For SW900 B) Turn the ignition key to “I”.

(For SW900 P) Turn the ignition key to “I” and start the petrol engine (as shown in the User Manual); wait a few minutes that the engine reaches the target speed.
2. When the drive control lever (A) is completely released, check that the machine does not move and that there is no noise (whistling, etc.) caused by the drive belt.
3. Gradually bring the drive control lever (A) to half stroke: In this condition, the machine should start to move, but it must be still easy to hold it in place by pulling the handlebar (B); there must be no noise (whistling, etc.) caused by the drive belt.

4. Carefully bring the drive control lever (A) until the end of the stroke; in this condition, the machine must move at maximum speed.
5. If necessary, adjust the tension as shown below.

Adjustment

6. Loosen the nut and locknut (C) and adjust the drive system control cable (D) until the required conditions described at points 2., 3., 4. are reached.

After adjusting, tighten the nut and locknut (C).

Reassembly

7. Turn the ignition key to “0”.

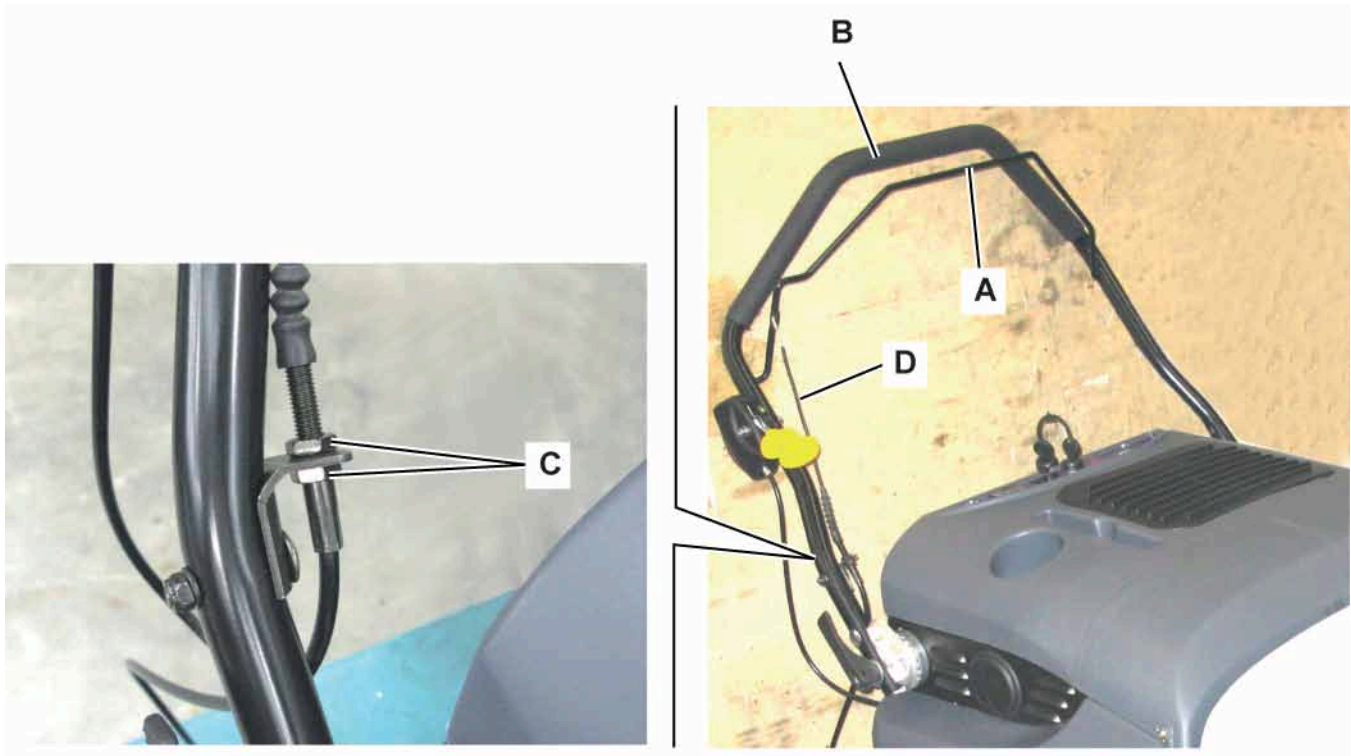

Troubleshooting

Trouble	Possible causes	Remedy
When pulling the drive control lever, the machine does not move, or it moves slowly.	The drive control cable is misadjusted or broken.	Adjust or replace the drive control cable.
	The drive belt is misadjusted or worn.	Adjust or replace the drive belt.

Removal and Installation

Drive system control cable, disassembly/assembly

Disassembly

1. Remove the drive belt (see the procedure in the relevant paragraph).
2. Unscrew the nut (B) on the front end of the drive system control cable (A).
3. Disconnect the cable (A) from the slot (C) on the holder.
4. Disengage the spring terminal (D) from the tensioner (E).
5. Loosen the nut (F) on the handlebar.
6. Disconnect the cable (G) from the slot (H) on the holder.
7. Remove the terminal (I) of the cable (G) from the housing of the drive control lever (J).
8. Retrieve the drive system control cable (G).

Assembly

9. Assemble the drive system control cable in the reverse order of disassembly.
10. Adjust the drive system control cable (see the procedure in the relevant paragraph).

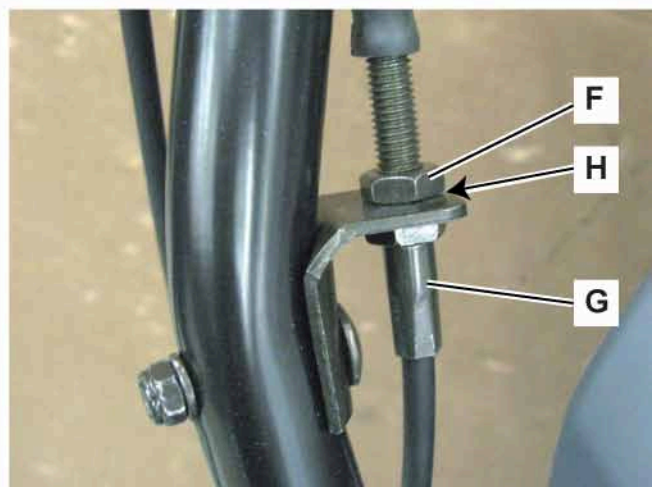
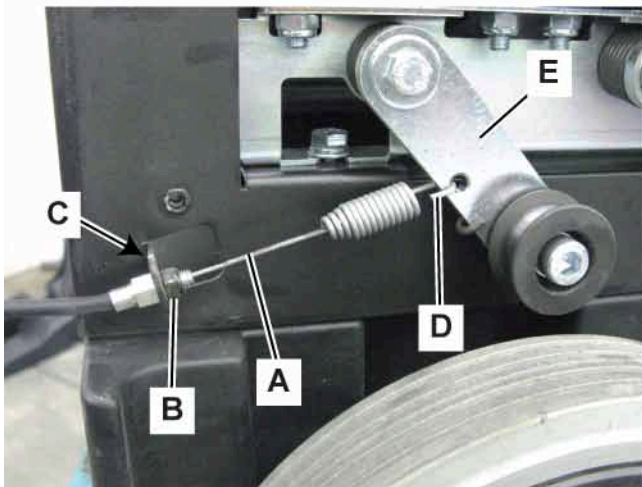
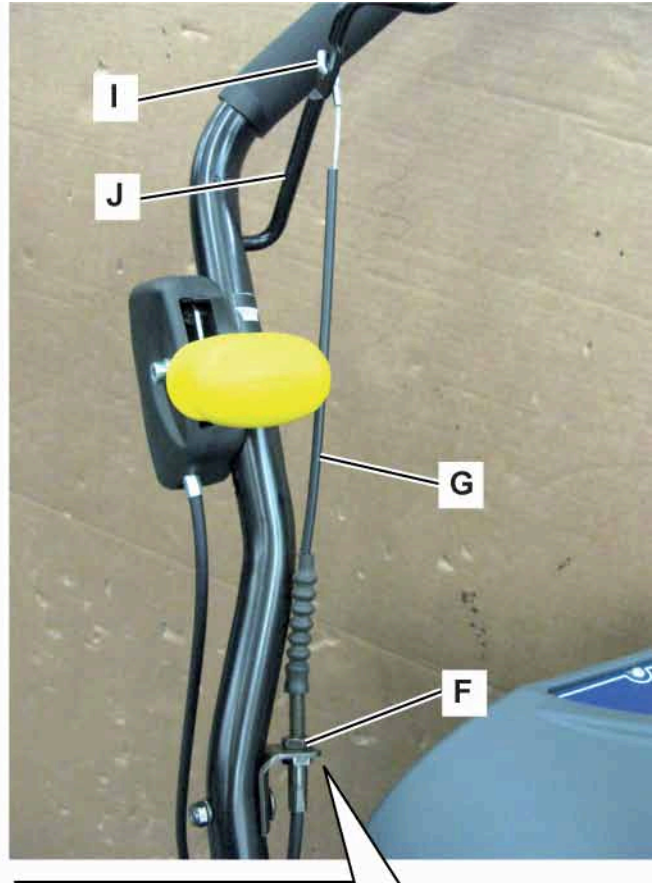

Drive belt, check/replacement

Check

1. Drive the machine on a level floor and ensure that it cannot move.
2. Turn the ignition key to “0”.
3. Remove the hopper by using its transport handle and wheels.
4. Disengage the front fastener and open the battery/engine compartment hood.
5. Remove the screws (A) and the right side panel (B) from the machine.
6. Visually inspect the entire length of the drive belt (C) to make sure it is intact and shows no signs of cuts, tears or cracks, if necessary replace it. If necessary, replace the belt.
7. Check that the flexible tensioner (D) is working and that it operates correctly on the drive belt (C). Check that the rotation pulleys of the belt (C) rotate freely and are free from dirt and foreign materials (ropes clothes, etc.) accidentally rolled up on their rotation shafts.

Replacement

8. Move the flexible tensioner (D) away from the belt (C), then release the belt from the pulley (E).
9. Remove the belt (C) by disengaging it from the lower pulley and from the drive wheel (F), by gently lifting the wheel itself.
10. Install the new belt (C) by performing the steps 3. to 9. in the reverse order.
11. Check the drive system control cable (see the procedure in the relevant paragraph).

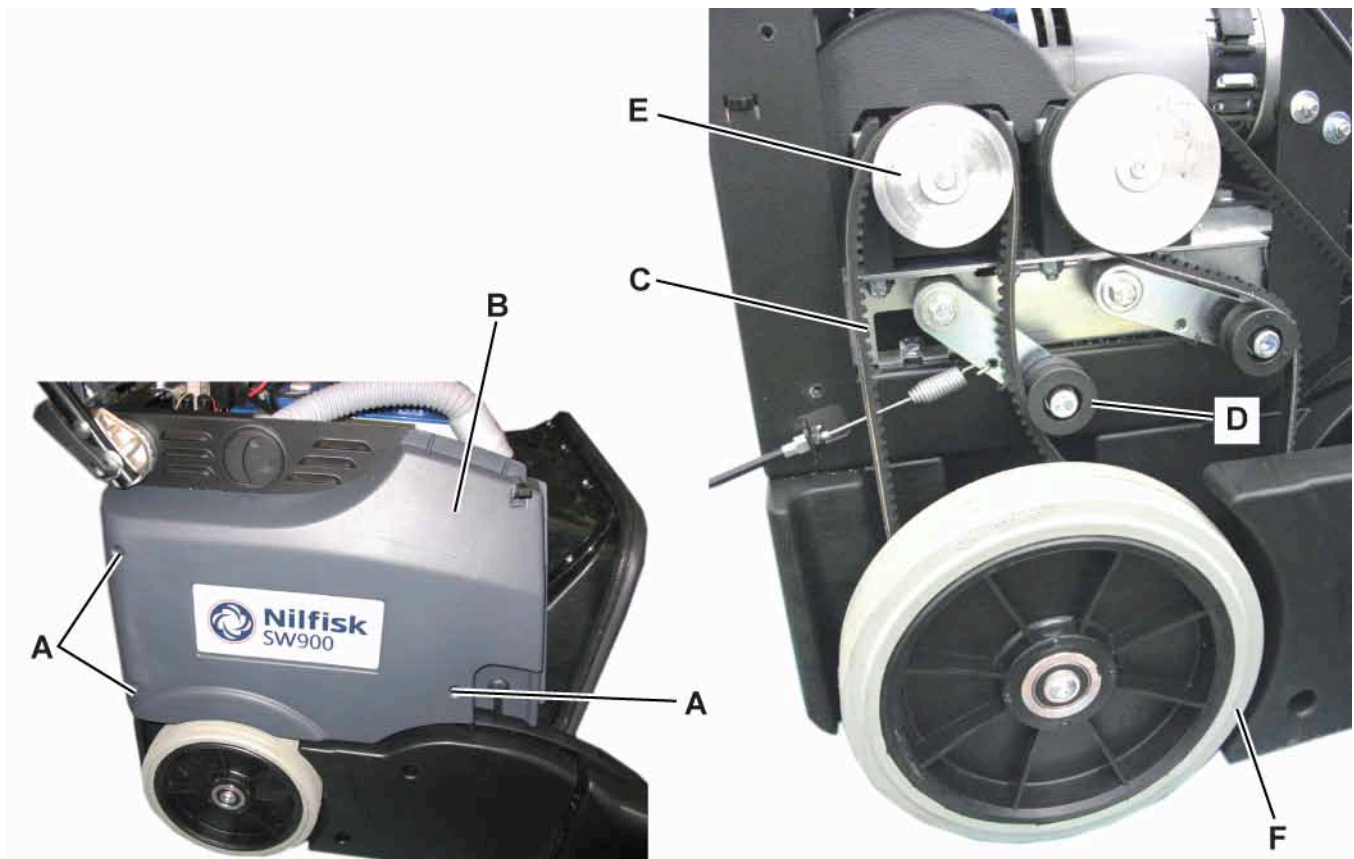

Specifications

Model		Advance / Nilfisk SW900 B	Nilfisk SW900 P
Drive	forward speed	2.8 mi/h (4.5 km/h)	
Maximum gradient when working		2 %	
Gradeability at full load and during transfer		18 %	
Front wheels (quantity, diameter, width)		N°1 Ø3.9 x 1.2 in (N°1 Ø100 x 30 mm)	
Rear wheels (quantity, diameter, width)		N°2 Ø9.8 x 2.1 in (N°2 Ø250 x 54 mm)	
Minimum hallway width		40.9 in (1,040 mm)	
Front – rear wheelbase		33.6 in (853 mm)	
Track (centres of rear wheels)		28.6 in (727 mm)	