



## Electronic Service Manuals

This electronic document is provided as a service to our customers. We do not create the contents of the information contained in this document. Should you have detailed questions pertaining to the information contained in this document, you may contact Michco, or the manufacturer which provided the original information in this electronic deliverable. Michco's only part in this electronic deliverable was the electronic assembly process. By providing this manual on line we are not guaranteeing parts availability.

You may contact Michco through the following methods:

Phone (517) 484-9312 or (800) 331-3339

2011 N. High St. -- Lansing, Michigan -- 48906

Fax: (517) 484-9836

Email: [CustServe@Michco.com](mailto:CustServe@Michco.com)

Web site: [www.Michco.Com](http://www.Michco.Com)

Parts Web site: [www.FloorMachineParts.Com](http://www.FloorMachineParts.Com)

Order Parts on Line at:

**[www.FloorMachineParts.Com](http://www.FloorMachineParts.Com)**

Directly to Parts & Service:

By Email: **[Shop@Michco.com](mailto:Shop@Michco.com)**

By Fax: (517) 702-2041

By Voice: Use numbers above.

**Serving the Cleaning Industry Since 1922**

Notice: All copyrighted material remains property of original owners, all trademarks are property of respective owners. Manuals are subject to Manufacturer's reproduction limitations. Originals or reproductions were provided by manufacturers through a request. We make no warranty as to the correctness of information provided in this document and you assume all risk. By placing these manuals on line we are not declaring our corporation to be an manufacturer authorized dealer or provider, please check our web site for authorized manufacturers we represent.

# ES4000™

---



---

## Service Manual

Advance Model 56344200



English

06/11 Revised 11/13 Form No. 56043152

# Contents

|   |           |
|---|-----------|
| <b>General Information</b> . . . . .                            | <b>6</b>  |
| General Machine Description . . . . .                           | 6         |
| Document Revision History . . . . .                             | 6         |
| Nameplate . . . . .   | 7         |
| Transporting the Machine. . . . .                               | 7         |
| Towing . . . . .  | 8         |
| Other Manuals Available . . . . .                               | 8         |
| Cautions and Warnings Symbols . . . . .                         | 8         |
| General Safety Instructions . . . . .                           | 9         |
| Functional Description for Battery Condition Displays . . . . . | 10        |
| Functional Description of Additional Status Displays . . . . .  | 10        |
| Know Your Machine . . . . .                                     | 12        |
| Control Panel. . . . .  | 13        |
| Component Descriptions. . . . .                                 | 14        |
| Functional Description of Control Switches . . . . .            | 16        |
| Maintenance . . . . .   | 18        |
| Maintenance Schedule . . . . .                                  | 18        |
| Vacuum Shoe Maintenance . . . . .                               | 19        |
| Spray Nozzle Maintenance . . . . .                              | 19        |
| Lubricating the Machine . . . . .                               | 19        |
| Cleaning the Vacuum Motor Filters . . . . .                     | 19        |
| Scrub Brush Maintenance . . . . .                               | 19        |
| Specifications . . . . .  | 23        |
| General . . . . .   | 23        |
| Battery Compartment Dimensions . . . . .                        | 24        |
| Minimum Aisle Turn Around Radius (turning left) . . . . .       | 24        |
| Minimum Door Pass-Thru Width . . . . .                          | 24        |
| <b>Chassis System</b> . . . . .                                 | <b>25</b> |
| Functional Description—Main Components . . . . .                | 25        |
| <b>Control System</b> . . . . .                                 | <b>27</b> |
| Functional Description. . . . .                                 | 27        |
| Control System Circuit Descriptions . . . . .                   | 28        |
| Functional Description of Main Controller . . . . .             | 30        |
| Component Locations . . . . .                                   | 31        |
| Maintenance and Adjustments . . . . .                           | 34        |
| Hidden Menus . . . . .  | 34        |
| Program Option Settings . . . . .                               | 34        |
| Service Test Mode . . . . .                                     | 39        |
| Extra Info on LCD . . . . .                                     | 43        |
| Troubleshooting . . . . .                                       | 47        |
| Fault Codes. . . . .  | 47        |
| Removal and Installation . . . . .                              | 53        |
| Replace the Main Control Board . . . . .                        | 53        |
| Specifications . . . . .  | 55        |
| Shop Measurements – Main Controller. . . . .                    | 55        |

|  |           |
|--|-----------|
| <b>Electrical System</b> . . . . .                           | <b>58</b> |
| Functional Description . . . . .                             | 58        |
| Battery Specifications . . . . .                             | 62        |
| Battery Charger (on-board and portable) . . . . .            | 62        |
| Removal and Installation . . . . .                           | 62        |
| Install Batteries . . . . .                                  | 63        |
| When Servicing Batteries:. . . . .                           | 63        |
| Battery Low Voltage Cutout Feature - Description . . . . .   | 66        |
| Battery Condition Indicator - Description . . . . .          | 66        |
| Battery LOCK Value. . . . .                                  | 67        |
| Maintenance and Adjustments . . . . .                        | 69        |
| Battery Maintenance . . . . .                                | 69        |
| Charging the Batteries . . . . .                             | 69        |
| To Charge the Batteries. . . . .                             | 69        |
| Battery Testing . . . . .                                    | 70        |
| Machine and Chassis Wiring . . . . .                         | 71        |
| Machine and Chassis Wiring . . . . .                         | 72        |
| Specifications . . . . .                                     | 73        |
| INPUT/OUTPUT TABLES . . . . .                                | 73        |
| Shop Measurements – Main Controller. . . . .                 | 78        |
| Wiring (Ladder) Diagram 56344090 Rev. C (1 of 2) . . . . .   | 81        |
| Wiring (Ladder) Diagram 56344090 Rev. C (2 of 2) . . . . .   | 82        |
| Wiring Harness Diagram 56344091 Rev. C (1 of 2). . . . .     | 83        |
| Wiring Harness Diagram 56344091 Rev. C (2 of 2) . . . . .    | 84        |
| <b>Options and Accessories</b> . . . . .                     | <b>85</b> |
| Options . . . . .  | 85        |
| Accessories . . . . .  | 87        |
| <b>Recovery System</b> . . . . .                             | <b>90</b> |
| Functional Description . . . . .                             | 90        |
| Recovery System—Vacuum General . . . . .                     | 90        |
| Recovery System Circuit Description . . . . .                | 91        |
| Component Locations . . . . .                                | 92        |
| Maintenance and Adjustments . . . . .                        | 94        |
| Recovery System Service Maintenance Checklist . . . . .      | 94        |
| Vacuum Filter and Float Cage Maintenance . . . . .           | 94        |
| Troubleshooting . . . . .                                    | 96        |
| Removal and Installation . . . . .                           | 97        |
| Vacuum Motor(s) Removal . . . . .                            | 97        |
| Recovery Tank Removal . . . . .                              | 98        |
| Vacuum Shoes Removal . . . . .                               | 100       |
| Recovery System Wet and Dry Pickups—Accessory Port . . . . . | 102       |
| Pickup Connectors. . . . .                                   | 102       |
| Wet Connection . . . . .                                     | 103       |
| Dry Connection . . . . .                                     | 103       |
| Accessory Port—Using Attachments . . . . .                   | 105       |
| Recovery Shoe Lift Actuator Removal and Adjustment . . . . . | 106       |
| Actuator Drive Screw Tube Adjustment . . . . .               | 108       |
| General Instructions for All Actuator Motors . . . . .       | 108       |
| Lift Actuator Drive Screw Tube Adjustment . . . . .          | 109       |
| Specifications . . . . .                                     | 110       |
| Special Tools . . . . .                                      | 111       |
| Actuator Power Cord Adaptor (part # 56407502). . . . .       | 111       |

|   |            |
|---|------------|
| <b>Solution System</b>                        | <b>112</b> |
| Functional Description                        | 112        |
| Solution System Circuit Description           | 113        |
| Component Locations                           | 114        |
| Troubleshooting                               | 121        |
| Mechanical / Electrical / Plumbing            | 121        |
| Maintenance and Adjustments                   | 121        |
| Purge Chemical Pump Weekly:                   | 122        |
| To Reset the Detergent Counter                | 122        |
| Detergent Ratio                               | 122        |
| Nozzle Maintenance                            | 125        |
| Chemical Pump Removal                         | 126        |
| Solution Solenoid Valve Removal               | 127        |
| Solenoid Valve Disassembly and Cleaning       | 128        |
| Specifications                                | 129        |
| <b>Scrub System</b>                           | <b>130</b> |
| Functional Description                        | 130        |
| Scrub System Circuit Description              | 131        |
| Component Locations                           | 132        |
| Maintenance and Adjustments                   | 133        |
| Scrub System Brush Maintenance                | 133        |
| Troubleshooting                               | 134        |
| Removal and Installation                      | 135        |
| Scrub Deck Removal                            | 135        |
| Scrub Deck Actuator Removal                   | 140        |
| Actuator Drive Nut Adjustment                 | 144        |
| General Instructions for All Actuator Motors  | 144        |
| Scrub Deck Lift Actuator Drive Nut Adjustment | 145        |
| Brush Motor Removal                           | 147        |
| Scrub Brush Belt Replacement                  | 149        |
| Scrub Brush Removal and Installation          | 150        |
| Specifications                                | 151        |
| Scrub System                                  | 151        |
| Special Tools                                 | 152        |
| Actuator Power Cord Adaptor—Part # 56407502   | 152        |
| <b>Steering System</b>                        | <b>153</b> |
| Functional Description                        | 153        |
| Maintenance and Adjustments                   | 154        |
| Removal and Installation                      | 155        |
| Steering Column shroud removal                | 155        |
| <b>Wheel System, Non-Traction</b>             | <b>157</b> |
| Functional Description                        | 157        |
| Component Locations                           | 157        |
| Removal and Installation                      | 158        |
| Replacing the Rear Wheels                     | 158        |

**Wheel System, Traction . . . . . 159**

- Functional Description . . . . . 159
  - Wheel System, Traction Circuit Description . . . . . 160
- Component Locations . . . . . 164
- Maintenance and Adjustments . . . . . 165
  - Curtis Speed Controller Installation Checkout Procedure. . . . . 165
- Troubleshooting . . . . . 166
  - General Troubleshooting . . . . . 166
  - Speed Controller Diagnostics . . . . . 168
  - Speed Controller Status Light /Display Functions . . . . . 168
  - Wheel Drive Circuit Error Codes / Speed controller Error Flash Codes. . . . . 169
- Removal and Installation . . . . . 171
  - Drive Pedal Replacement . . . . . 171
  - Potentiometer Testing . . . . . 172
  - Testing the Potentiometer. . . . . 172
  - Replacing the Drive Wheel Assembly. . . . . 173
  - Replacing the Drive Tire . . . . . 176
  - Inspecting/Replacing the Drive Wheel Assembly Carbon Brushes . . . . . 177
- Specifications . . . . . 179
- Special Tools . . . . . 179

## General Information

---

### General Machine Description

The ES4000 is a commercial rider extractor. The ES4000 has two solution flow options and on board chemical to allow for varying extraction needs. The ES4000 also has the ability to be a sweeper by vacuumizing the deck and recovering soil in the recovery tank.

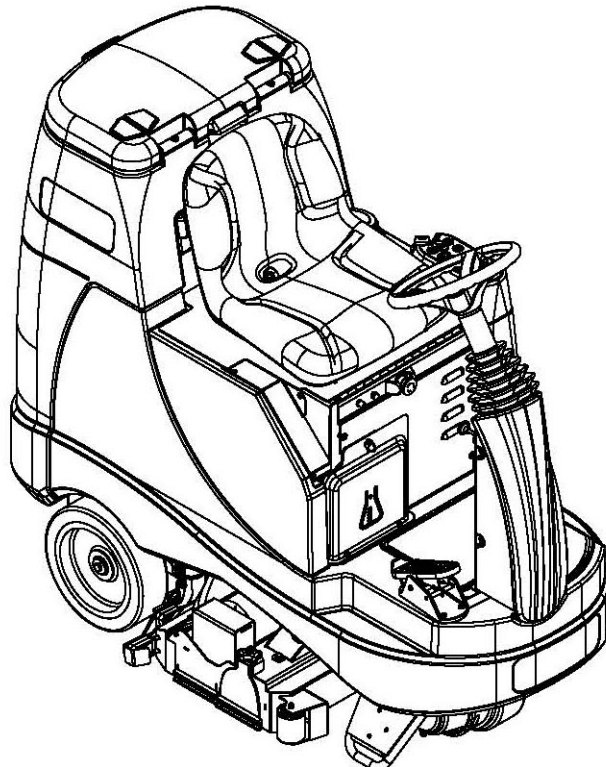

### Service Manual Purpose and Application

This Service Manual is a technical resource designed to aid service personnel in maintaining and repairing the ES4000 Sweeper/Extractor to ensure optimum performance and long service life. Please read it thoroughly before servicing your machine.

**Note:** Bold numbers and letters in parentheses and underlined indicate an item illustrated on pages 12-14 i.e. **(B)**.

### Document Revision History

- 05/12
  - Expanded Table of Contents
  - Turned some pages to landscape orientation for easier viewing on a computer screen
  - Added engineering identification information to wiring (ladder) diagrams and wiring harness diagrams.

- 11/13
  - General Information: Added missing vibration specification values
  - Electrical System: Corrected minimum voltage reset value following low voltage cut out from 24.6v to 25.08v

## Nameplate

The Model Number and Serial Number of your machine are shown on the Nameplate on the machine. The nameplate is mounted on the steering column facing the driver. This information is needed when ordering repair parts for the machine. Use the space below to note the Model Number and Serial Number of your machine for future reference.



Nameplate

## Transporting the Machine

- ⚠ CAUTION!** Before transporting the machine on an open truck or trailer, make sure that . The machine is tied down securely - see Figure G-1. All access doors and covers are secured (tape and strap as necessary).

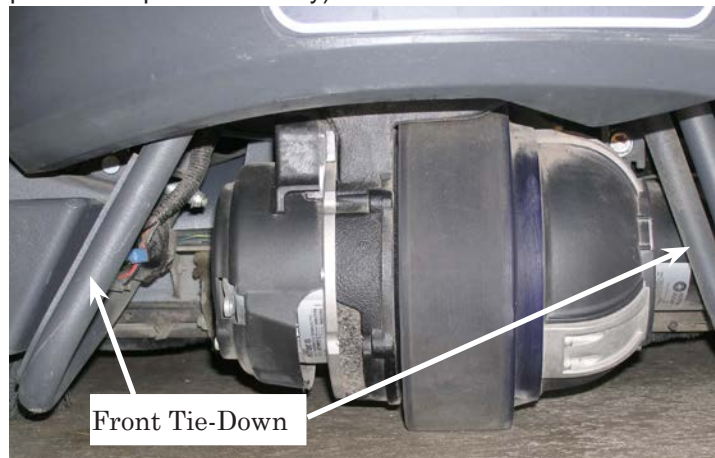

Figure G-1

## Towing



**CAUTION!** If the machine must be towed or pushed, make sure the Key Switch (Main Power) (J) is in the OFF position and do not move the machine faster than a normal walking pace (2-3 mph, 3-5 kph) and for short distances only. Disengage the electromagnetic brake by wedging an angle bar or flat head screwdriver between the brake lever and motor as shown in the photo below.



## Other Manuals Available

The following manuals are available from the Advance Literature Service Department, for your Rider Extractor:

Parts List - Form Number 56042573

Operation Manual - Form Number 56091013

## Cautions and Warnings Symbols

Advance uses the symbols below to signal potentially dangerous conditions. Always read this information carefully and take the necessary steps to protect personnel and property. (Triangle Symbol may or may not be used).



**DANGER!** Is used to warn of immediate hazards that will cause severe personal injury or death.



**WARNING!** Is used to call attention to a situation that could cause severe personal injury.



**CAUTION!** Is used to call attention to a situation that could cause minor personal injury or damage to the machine or other property.

## General Safety Instructions

Specific Cautions and Warnings are included to warn you of potential danger of machine damage or bodily harm.

 **WARNING! This machine shall be used only by properly trained and authorized persons.**

### Other Warnings:

- While on ramps or inclines, avoid sudden stops when loaded. Avoid abrupt sharp turns. Use low speed down hills. Clean only while ascending (driving up) the ramp.
- Keep sparks, flame and smoking materials away from batteries. Explosive gases are vented during normal operation.
- Charging the batteries produces highly explosive hydrogen gas. Charge batteries only in well-ventilated areas, away from open flame. Do not smoke while charging the batteries.
- Remove all jewelry when working near electrical components.
- Turn the key switch off (O) and disconnect the batteries before servicing electrical components.
- Never work under a machine without safety blocks or stands to support the machine.
- Do not dispense flammable cleaning agents, operate the machine on or near these agents, or operate in areas where flammable liquids exist.
- Do not clean this machine with a pressure washer.

 **CAUTION! This machine is not approved for use on public paths or roads.**

### Other Cautions:

- This machine is not suitable for picking up hazardous dust.
- When operating this machine, ensure that third parties, particularly children, are not endangered.
- Before performing any service function carefully read all instructions pertaining to that function.
- Do not leave the machine unattended without first turning the key switch off (O), removing the key and applying the parking brake.
- Turn the key switch off (O) before changing the brushes, and before opening any access panels.
- Take precautions to prevent hair, jewelry, or loose clothing from becoming caught in moving parts.
- Use caution when moving this machine in below freezing temperature conditions. Any water in the solution or recovery tanks or in the hose lines could freeze, causing damage to valves and fittings. Flush with windshield washer fluid.
- The batteries must be removed from the machine before the machine is scrapped. The disposal of the batteries should be safely done in accordance with your local environmental regulations.

## Functional Description for Battery Condition Displays

The battery condition indicator (**K**) consists of three lights; a green (**K3**), a yellow (**K2**) and a red (**K1**). A fully charged battery pack will measure above 24 volts with no load applied. The ES4000 is equipped with a low voltage cutout feature that will turn the scrub system off when the batteries are discharged to their minimum level. There are two different cutout levels to accommodate different battery types. See the Electrical System “Main Control Board Special Program Options” for details. The voltage levels for the various indications are as follows (the voltages shown represent the voltage under load):

|                     | Standard    | Alternate   |
|---------------------|-------------|-------------|
| Green               | 22.00+      | 22.50+      |
| Green & Yellow      | 21.00-21.99 | 22.00-22.49 |
| Yellow              | 20.00-20.99 | 21.50-21.99 |
| Yellow & Red        | 19.50-19.99 | 21.00-21.49 |
| Red                 | 19.00-19.49 | 21.50-21.99 |
| Flashing Red/Cutoff | <19.00      | <21.50      |



*NOTE: When the low voltage cutout level has been reached (flashing red indicator) the batteries must be FULLY recharged (25.08V) to reset the battery condition indicator. The scrub system will not function until the indicator has been reset.*

## Functional Description of Additional Status Displays

The character display on the control panel is used as a display for all functional codes. This display is also used to display the following information depending upon which mode the control is in:

- Error codes\*
- Display of control system default parameters\*
- Recovery tank FULL indicator\*
- If any of the systems on the machine are on or if the throttle is not in neutral, the display will be blank.



*\* NOTE: Reference (in the Electrical System manual section) the Main Control Board Troubleshooting Guide and the Control Board Special Program Options sections. These sections will explain the machine error code descriptions and cleaning system controller default parameter changes.*

## KNOW YOUR MACHINE

As you read this manual, you will occasionally run across a bold number or letter in parentheses - example: **(2)**. These numbers refer to an item shown on these pages unless otherwise noted. Refer back to these pages whenever necessary to pinpoint the location of an item mentioned in the text.

- |  |                                     |
|--|-------------------------------------|
| 1 Operator's Seat                          | 11 Front Roller Bumper              |
| 2 Seat Adjustment Knob                     | 12 Brush Idler Removal Knob         |
| 3 Emergency Stop                           | 13 Brush Deck                       |
| 4 Control Circuit Circuit Breaker (10 Amp) | 14 Debris Hopper                    |
| 5 Drive Wheel Circuit Breaker (70 Amp)     | 15 Vacuum Shoes                     |
| 6 Detergent Cartridge Access Cover         | 16 Solution Tank Drain Hose         |
| 7 Battery Charger (optional)               | 17 Rear Wheel                       |
| 8 Battery Charger Access Door              | 18 Detergent Cartridge              |
| 9 Drive Wheel                              | 19 Battery Compartment (under seat) |
| 10 Drive Pedal, Directional/Speed          | 20 Solution Spray Jets              |

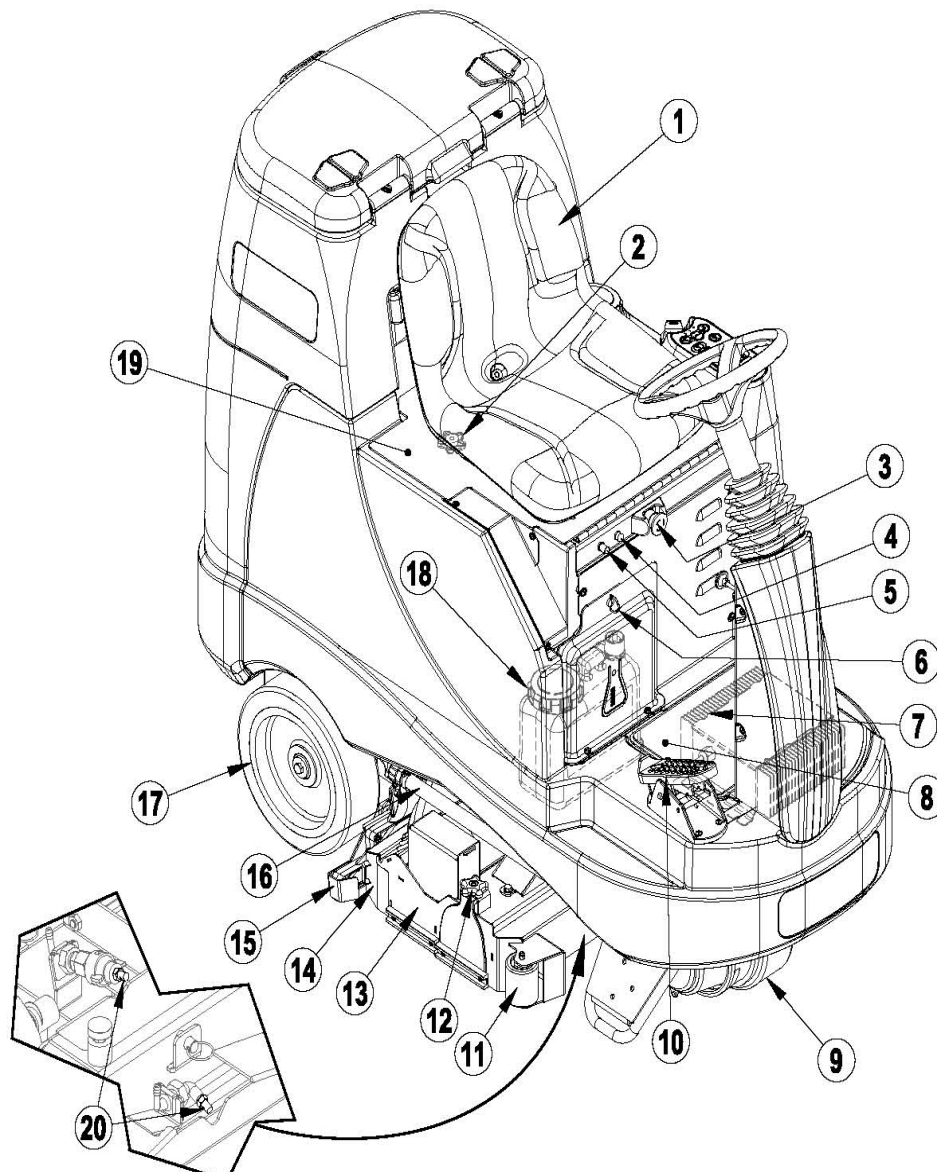

### Know Your Machine

- 21. Steering Wheel Tilt Adjust Knob
- 22. Control Panel
- 23. Solution Tank Fill Cover
- 24. Recovery Tank Cover
- 25. Vacuum Motor Filter Housing
- 26. Strainer Basket
- 27. Recovery Tank Shutoff Float
- 28. Recovery Tank Drain Hose
- 29. Recovery Hose
- 30. Dry Mode Port
- 31. Accessory Port
- 32. Seat Prop Rod
- 33. Rear Brush End Cap
- 34. Machine Battery Connector
- 35. Solution Filter
- 36. Solution Shutoff Valve
- 37. Steering Wheel
- 38. Wet Mode Port

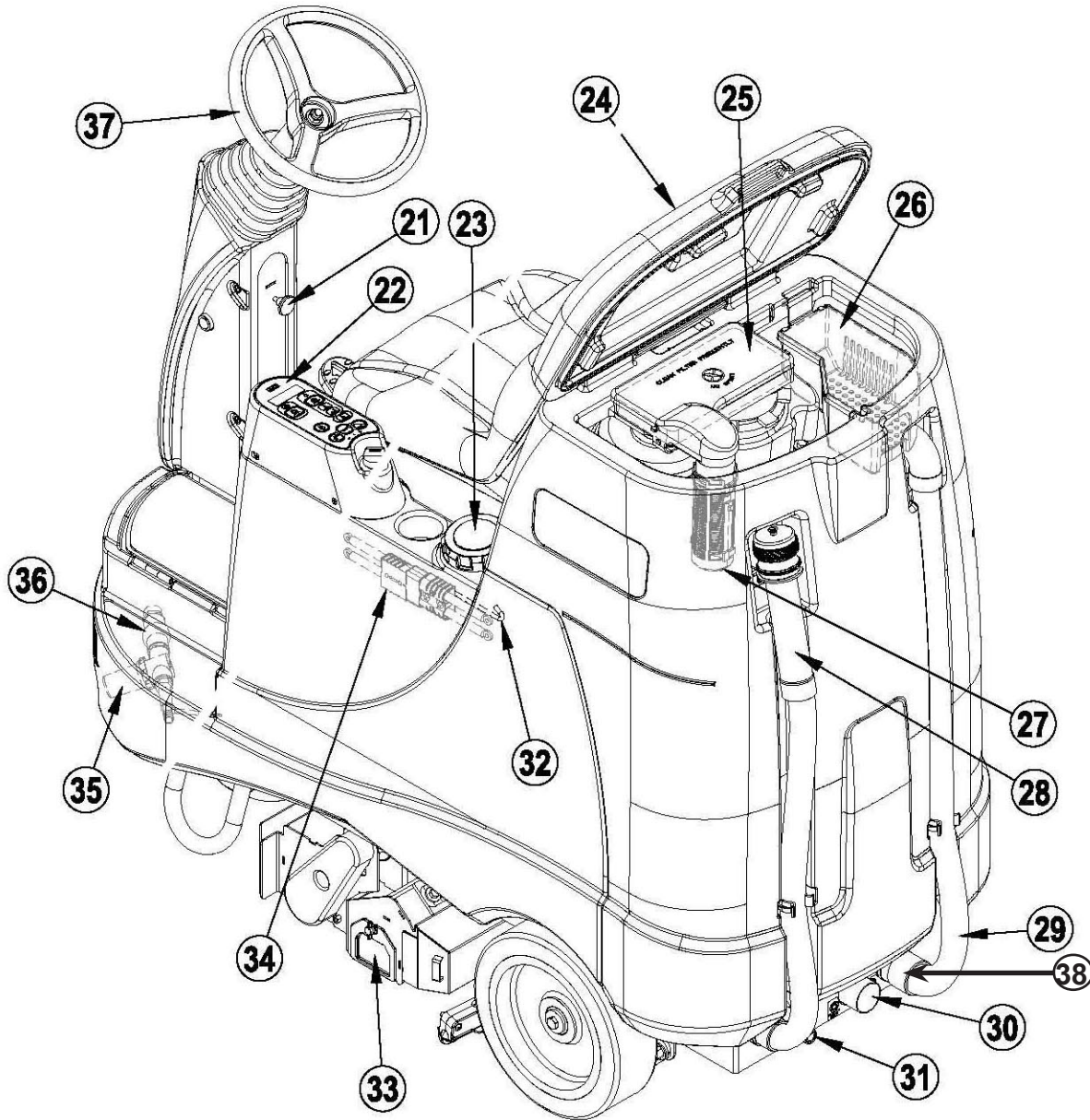

### Control Panel

- A. Key Switch / Main Power
- B. Solution ON/OFF Switch
- C. Detergent ON/OFF Switch
- D. Dry Mode Switch
- E. LCD Display
  - E1. Hour Meter
  - E2. Fault Codes
  - E3. Solution Tank Level Indicator
  - E4. Transport Mode Indicator
  - E5. Detergent Indicator
  - E6. Detergent Ratio Indicator
  - E7. Battery Indicator
  - E8. Prespray mode Indicator
  - E9. Maintenance Mode Indicator
  - E10. Restore Mode indicator
  - E11. Sweep Mode Indicator
  - E12. Recovery Tank Full Indicator
  - E13. Low Voltage Cutout Indicator
- F. Wet Mode Switch
- G. Interim Mode Switch
- H. Restorative Mode Switch
- I. PreTreat Mode Switch
- J. Horn Switch
- K. Vacuum ON/OFF Switch

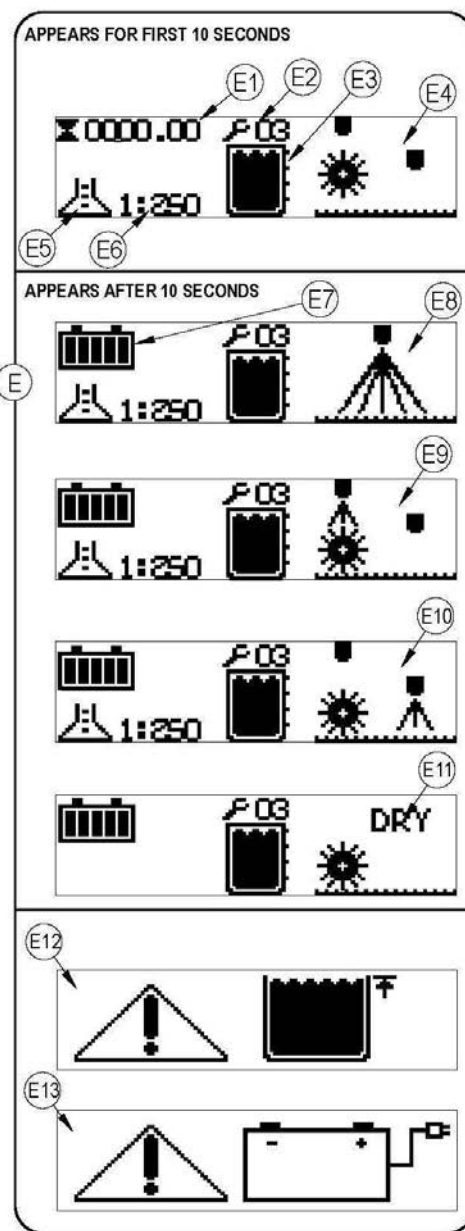
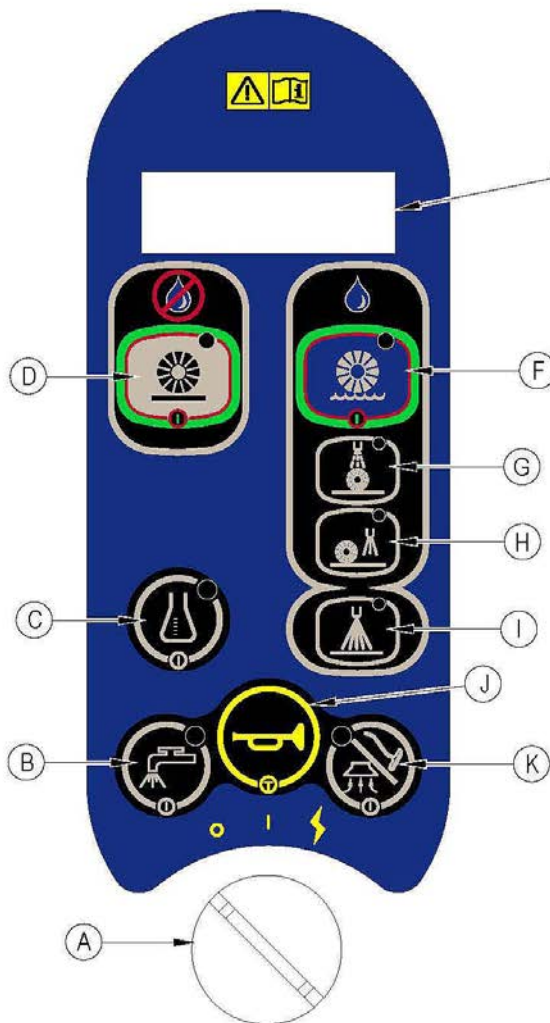

## Component Descriptions

Reference machine drawings on the previous pages of this section.

- **Emergency Stop / Battery Disconnect (3)** – Push in on lever to disconnect batteries.
- **Control Circuit Circuit Breaker (4)** – Provides overload protection, 10 Amp. If it trips, it will pop out. To reset, wait one minute and press the button back in.
- **Wheel Drive Circuit Breaker (5)** – Provides overload protection to machine's wheel drive motor, 45 Amp. If it trips, it will pop out. To reset, wait one minute and press the button back in.
- **Detergent Cartridge Access Cover (6)**—Insert the detergent cartridge in this area. Replace when empty.
- **Battery Charger (7)**—Charges batteries when plugged into an AC outlet.
- **Battery Charger Access Door (8)**—Access the charger through this cover.
- **Drive and Steer Wheel (9)** – Wheel drive motor attached to this wheel to propel machine either forward or reverse. Also attached to Steering Wheel for steering left or right.
- **Drive Pedal, Directional / Speed (10)** – The operator can make the machine go forward by pushing forward on it, or reverse by pulling backward on it. The speed is variable depending on how far forward or backward the pedal is moved.
- **Front Roller Bumper (11)**—Keeps machine safe distance from walls and other obstacles.
- **Brush Idler Removal Knob (12)**—Removes idler for brush assembly.
- **Brush deck (13)**—Contains brush drive motor(s), brush(es) and solution spray jets.
- **Debris Tray (14)**—Collects debris that has been swept up by the machine. Empty and clean daily.
- **Vacuum Shoes (15)**—Removes excess solution from carpet after Extraction.
- **Solution Tank Drain Hose (16)**—Used to empty the solution tank.
- **Rear Wheel (17)**—These two wheels along with the drive wheel, support the machine. Power and steering are supplied through the front drive wheel.
- **Detergent Cartridge (18)**—Contains carpet treatment/detergent.
- **Battery Compartment (19)**—Batteries stored here, flip seat panel up to access.
- **Solution Spray Jets (20)**—Based upon which extraction mode is selected (interim or restorative) the solution will be sprayed out one of the two different jets.

- **Steering Wheel Tilt Adjust Knob (21)**—Push down on this knob to adjust the Steering Wheel up or down.
- **Control Panel (22)**—Operator Controls found here, see “FUNCTIONAL DESCRIPTION OF CONTROL SWITCHES”.
- **Solution Tank Fill Cover (23)**—Open to fill the solution tank. Total capacity is 40 gallons (151 Liters).
- **Recovery Tank Cover (24)** – Open to access Recovery Tank for cleaning.
- **Vacuum Motors’ Filter Housing (25)** – Location of Vacuum Motors air intake filters.
- **Strainer Basket (26)**—Catches large to mid-size debris in Recovery Tank.
- **Recovery Tank Shutoff Float (27)**—Shuts off fluid flow from Recovery System when tank is full.
- **Recovery Tank Drain Hose (28)**—Used to empty the recovery tank.
- **Recovery Hose (29)**—Hose used to recover solution from carpet and deposit into Recovery Tank.
- **Dry Mode Port (30)**—Attach Recovery Hose (29) when using the Dry Sweep Mode.
- **Accessory Port (31)**—Solution attachment for additional accessories.
- **Seat Prop Rod (32)**—Props the seat upright for access to batteries and battery connector.
- **Rear Brush End Cap (33)**—Access to rear brush.
- **Machine Battery Connector (34)**—Batteries plug into this connector, disconnect to charge batteries.
- **Solution Filter (35)**—Filters solution prior to entering pump and being sprayed on the floor.
- **Solution Shutoff Valve (36)**—This valve should be fully open whenever operating ES4000. Only close this valve before removing the solution filter to prevent loss of solution.
- **Steering Wheel (37)**—Steers the machine just like an automobile. Directs the Wheel Drive System.
- **Wet Mode Port (38)**—Attach Recovery Hose (29) when using any wet mode.

## Functional Description of Control Switches

The controls on the ES4000™ were designed with *one touch operation* in mind. For single pass extracting the user can simply depress one switch and all systems on the machine will be ready to go. For most single-pass extracting operations, the operator should only need to use one of the switches on the control panel. Two of these are the Interim Mode and Restorative Mode switches. In the Interim Mode the solution spray is directed at the scrub brush and the flow rate is reduced. The travel speed is limited to a medium speed. In the Restorative Mode the solution spray is directed at the carpet ahead of the scrub brush and the flow is at maximum. The travel speed is limited to a slow speed.

See drawing on previous pages in this section.

**Dry Mode Switch (D)**—Pressing this switch when the deck system is active will cause the following to occur:

- The brush(es) will turn off and the deck will raise to the up position
- The solution flow will be stopped
- The vacuum will shut off after a 10 second delay
- The travel speed limit will return to the transport speed setting

**Interim Mode Switch (G)**—If the scrub system is off, pressing this switch will cause the following to occur:

- The system will be enabled with the system configured for Interim Mode and the deck will be lowered
- The vacuum system will be enabled
- The solution system will be enabled for Interim Mode
- The travel speed will be limited to the Interim Mode speed setting
- As soon as the throttle is moved from the neutral position the scrub brush(es) will start turning and the vacuum will turn on. If the direction is forward the solution flow will start. If the direction is reverse the solution flow will be stopped. It is possible to program the control to automatically raise the scrub deck in reverse. Refer to the Electrical System “Main Control Board Special Program Options” for details.

 *Note: If the Restorative Mode is selected, pressing this switch will select the Interim Mode. If the Interim Mode is already selected, pressing this switch will have no effect.*

**Restorative Mode Switch (H)**—If the scrub system is off, pressing this switch will cause the following to occur:

- The scrub system will be enabled with the system configured for Restorative Mode and the scrub deck will be lowered
- The vacuum system will be enabled
- The solution system will be enabled for Restorative Mode
- The travel speed will be limited to the Restorative Mode speed setting
- As soon as the throttle is moved from the neutral position the scrub brush(s) will start turning and the vacuum will turn on. If the direction is forward the solution flow will start. If the direction is reverse the solution flow will be stopped. It is possible to program the control to automatically raise the scrub deck in reverse. Refer to the Electrical System “Main Control Board Special Program Options” for details.

 *Note: If the Interim Mode is selected, pressing this switch will select the Restorative Mode. If the Restorative Mode is already selected, pressing this switch will have no effect.*

**Key Switch / Main Power (A)**—Main Power Switch. See the Electrical System “Main Control Board Special Program Options” for details.

The Interim Mode, and Restorative Mode speed limits can be programmed using a Curtis handheld programmer. Refer to the Electrical System “Main Control Board Special Program Options” for details.

**Horn Switch (J)**—This switch will sound the horn as long as the switch is held. The horn also functions as an automatic back-up alarm when the throttle is moved to the reverse position. The volume of the back-up alarm is programmable. It can also be programmed to provide an annunciation feature that will sound whenever the throttle is in the forward position. See the Electrical System “Main Control Board Special Program Options” for details.

**Vacuum ON/OFF Switch (K)**—This switch is used to turn the vacuum system on or off. Pressing this switch will alternate between on and off. The vacuum will only turn on when the throttle is moved from the neutral position. It will remain on for 10 seconds after the throttle returns to neutral.

The vacuum also has an automatic shutoff feature that will turn the vacuum and scrub systems off if the recovery bladder becomes full. If this occurs, the status display will show the word “FULL”. This feature can be disabled if desired. The shutoff threshold can also be adjusted if necessary. See the Electrical System “Main Control Board Special Program Options” for details.

**Solution ON/OFF Switch (B)**—This switch is used to turn the solution system on or off. Pressing this switch when the scrub system has been activated will alternate between on and off. The solution flow will only turn on when the throttle is moved from the neutral position in the forward direction. The solution flow will turn off if the throttle returns to neutral or is moved to reverse.

**Detergent ON/OFF Switch (C)**—Activates or deactivates the Detergent dispensing system. When the system is ON the pump is activated at a specific rate while the solution pump is running. The Detergent pump turns OFF whenever the solution pump is not running or when the detergent system is OFF. See Electrical Section for more details.

**LCD Display (E)**—Displays functions of the Control Panel and activity indicators.

**Wet Mode Switch (F)**—Activates and de-activates the extraction functions of the Recovery System. There are four states for this switch; ON, OFF, Standby/Transport and Flashing. See Electrical section for more details.

**PreTreat Mode Switch (I)**—PreTreat is activated from this switch. It is only active when the machine is in either Extract Standby or Extract ON modes. The switch is inactive whenever the machine is in the Dry Sweep Mode. See Electrical section for more details.

## Maintenance

### Maintenance Schedule

Maintenance intervals given are for average operating conditions. Machines used in severe operational environments may require service more often.

| MAINTENANCE ITEM   | Daily | Weekly | Monthly | Yearly |
|--|-------|--------|---------|--------|
| Charge Batteries   | x     |        |         |        |
| Check/Clean Tanks & Hoses  | x     |        |         |        |
| Check/Clean/ Power Brush(s)                                      | x     |        |         |        |
| Check/Clean Vacuum Shoes   | x     |        |         |        |
| Check/Clean Vacuum Shut-Off Float                                | x     |        |         |        |
| Check/Clean the vacuum motor foam filter(s)                      | x     |        |         |        |
| Empty debris hopper  | x     |        |         |        |
| Clean spray nozzles  |       | x      |         |        |
| Check each battery cell(s) water level                           |       | x      |         |        |
| Inspect brush deck   |       | x      |         |        |
| Inspect and clean solution filter                                |       | x      |         |        |
| Check foot/parking brake for wear and adjustment (if applicable) |       | x      |         |        |
| Lubrication - grease fittings                                    |       |        | x       |        |
| Check carbon brushes*  |       |        |         | x      |

 *Note: See the individual machine system sections for maintenance information.*

*\* Check vacuum motor carbon brushes (Qty 2) once a year or after 300 operating hours. Check brush motor carbon brushes (Qty 4) once a year or after 500 operating hours. Note if the vacuum or brush motor brushes are 9.5mm (3/8 inches) or shorter, replace them. Check wheel drive motor carbon brushes every 500 operating hours. The original length of each brush is 20mm (25/32 inches). Replace when shorter than 9.5 mm (3/8 inches) to obtain the same motor efficiency as a new brush.*

 **WARNING! Turn the key switch off and disconnect the battery before servicing the machine.**

## Vacuum Shoe Maintenance

Check the vacuum shoes daily, they can be removed to aid in cleaning, see “Removing the Vacuum Shoes” in the operators manual. Remove any built-up string, hair or carpet fibers. See the RECOVERY SYSTEM section of this manual for additional information.

## Spray Nozzle Maintenance

Remove the spray nozzles once a week. Soak the nozzles overnight in a vinegar solution to remove chemical deposits. See SOLUTION SYSTEM section of this manual for additional information.

## Lubricating the Machine

Once a month, pump a small amount of grease into each grease fitting on the machine until grease seeps out around the bearings.

Grease fitting locations are:

- Steering Wheel Shaft Universal joint

Once a month, apply light machine oil to lubricate the:

- Steering Chain
- General Pivot Points For the Brush Deck Linkage
- Cleaning Deck Adjustment Knobs (4)

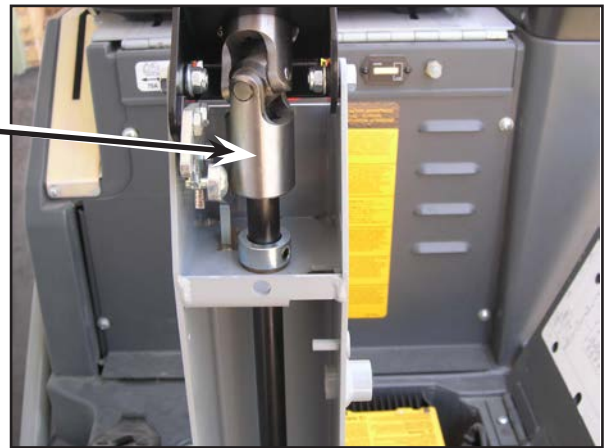

## Cleaning the Vacuum Motor Filters

Clean the vacuum motor filters daily with compressed air. For extremely dirty filters, wash with warm, soapy water and rinse thoroughly with clean water. Allow the filters to dry completely before re-installing in the machine. MAINTENANCE NOTE: Keep a second set of filters on hand to use while first set is drying.



## Scrub Brush Maintenance

Check the brush(s) daily. Remove any built-up string, hair or carpet fibers.



### Advance ES4000 PM Checklist

Customer \_\_\_\_\_  
 Address \_\_\_\_\_  
 City \_\_\_\_\_ St \_\_\_\_\_ Zip \_\_\_\_\_  
 Model \_\_\_\_\_ Serial \_\_\_\_\_ Hours \_\_\_\_\_

**Defect Codes**

- A** needs adjustment
- B** binding
- C** dirty or contaminated
- D** damaged, bent or torn
- L** leaks
- M** missing
- W** worn out

| Ref | OPERATIONAL INSPECTION ITEMS  | OK | Defect Codes<br>(circle) | Does Not Work |
|-----|---|----|--------------------------|---------------|
| 1   | Steering  |    | A<br>B                   |               |
| 2   | Drive Pedal Operation (check for Fwd/Rev Drive & any neutral creep)   |    | A    B<br>D              |               |
| 3   | Seat Safety Switch  |    | A<br>D                   |               |
| 4   | Brakes (Service & Parking)  |    | A    B<br>W              |               |
| 5   | Drive System Performance (reference SVR Manual for Curtis drive programmer speed changes)   |    | noisy<br>sluggish        |               |
| 6   | Deck System (Raise/Lower and test auto scrubbing functions Maintenance & Restoration)   |    | A<br>B                   |               |
| 7   | Vac Shoe Recovery System (Raise/Lower)  |    | A<br>B                   |               |
| 8   | Vacuum Performance (sealed water lift 64" and 1- inch open hole adapter 20 inches)  |    | C    L<br>W              |               |
| 9   | Solution Control (On/Off and flow volume Maintenance & Restoration)   |    | C    L<br>W              |               |
| 10  | Emergency Battery Disconnect Switch   |    | D                        |               |
| 11  | Tilt Steering Mechanism and Seat  |    | A    B<br>D              |               |
| 12  | Optional Accessories (headlight, safety beacon, etc.)   |    | D                        |               |
| 13  | Main Control Board Special Program Options (check all applicable program settings, reference SVR Manual 56043089); Example, Fault Recall Mode, Etc. |    | Program<br>as<br>needed  |               |
| 14  | Battery Charger Operation   |    | D                        |               |

| Ref | VISUAL INSPECTION ITEMS                              | Comments            | OK | Defect Codes<br>(circle) | Does Not Work |
|-----|--|---------------------|----|--------------------------|---------------|
| 15  | Scrub Brushes, check for wear and rotate             | Cylindrical         |    | A B<br>D<br>W            |               |
| 16  | Scrub Brush Motors                                   | Carbon Brushes      |    | B L<br>W                 |               |
| 17  | Scrub Brush Drive Belt, wear and tension             |                     |    | D<br>W                   |               |
| 18  | Scrub Brush Deck Actuator Motor                      |                     |    | A B<br>D<br>W            |               |
| 19  | Brush Deck Idler Assembly Bearings                   |                     |    | D<br>M                   |               |
| 20  | Scrub Deck Rear Deflector                            |                     |    | A B<br>W                 |               |
| 21  | Solution Solenoid Valves (Maintenance & Restoration) |                     |    | C<br>L                   |               |
| 22  | Solution Flow Control Valve                          |                     |    | A B<br>D<br>W            |               |
| 23  | Solution Tank, Delivery Hoses & Filter               | Clean Filter Screen |    | C<br>L                   |               |
| 24  | Vacuum Motor Carbon Brushes                          | Wear Limit 3/8"     |    | W                        |               |
| 25  | Vacuum Motor Gaskets and Filters                     |                     |    | L<br>W                   |               |
| 26  | Vacuum Float Ball & Cage Assembly                    | Clean Float         |    | C<br>M                   |               |
| 27  | Recovery Tank Cover Gasket                           |                     |    | C D<br>L                 |               |
| 28  | Recovery Tank Drain Hose & Cap                       | Flush               |    | C<br>L                   |               |
| 29  | Vacuum Pick-Up Tool & Hoses                          | Back flush          |    | C<br>L                   |               |

| Ref | VISUAL INSPECTION ITEMS (continued)                          | Comments        | OK | Defect Codes<br>(circle) | Does Not Work |
|-----|--|-----------------|----|--------------------------|---------------|
| 30  | Battery Pack Condition (clean & water)                       | Load Test       |    | C<br>W                   |               |
| 31  | Front Drive Wheel Motor                                      | Carbon Brushes  |    | C<br>W                   |               |
| 32  | Front Drive Tire (rim fastener torque)                       | Tread Wear      |    | W                        |               |
| 33  | Drive Pedal Linkage (neutral return)                         |                 |    | A<br>B                   |               |
| 34  | Steering Chain (lubricate & tension)                         | 1/4" Deflection |    | A    B<br>C              |               |
| 35  | Steering Column (knob & plunger spring) also Universal Joint | Grease          |    | A<br>D                   |               |
| 36  | Rear Wheels  |                 |    | W                        |               |
| 37  | Sweep Debris Tray  |                 |    | C                        |               |

*NOTE: For additional information see operator manual form number 56091013.*

Defect Codes

- |   |                  |   |                       |   |          |
|---|------------------|---|-----------------------|---|----------|
| A | needs adjustment | C | dirty or contaminated | M | missing  |
| B | binding          | D | damaged, bent or torn | W | worn out |
| L | leaks            |   |                       |   |          |

WORK COMPLETED BY:

ACKNOWLEDGED BY:

\_\_\_\_\_  
Service Technician Signature

\_\_\_\_\_  
Date

\_\_\_\_\_  
Customer Signature

\_\_\_\_\_  
Date

## Specifications

### General

|   |   |   |
|---|---|---|
| Machine Voltage   | 24 VDC  |   |
| Dimensions<br>(without Squeegee<br>and Scrub Deck)  | Length:   | 61 in (155 cm)  |
|   | Width (body):   | 27.5 in (70 cm)   |
|   | Height<br>(Recovery tank):  | Without Overhead Guard  |
| With Overhead Guard NA in   |   | (NA cm)   |
| Tank Capacities   | Solution Tank: 28.8 gal (109 L)                                     |   |
|   | Recovery Tank: dynamic: 24.7 gal ( 93 L); static: 28.6 gal ( 108 L) |   |
| Gross Weight (standard machine w/o options; w/full solution tank, empty recovery tank and heaviest batteries installed) |   | 1447 lbs ( 656 kg)  |
| Net Weight (standard machine w/o options, batteries or removable brushes; w/empty solution and recovery tanks)          |   | 587 lbs ( 266 kg)   |
| Static Wheel Loading  | Front: 587 lbs ( 266 kg)  | R Rear: 463 lbs (210 kg)<br>L Rear: 401 lbs. (182 kg)   |
| Static Wheel Pressure   | Front: 178.64 psi ( 12.56 kg/cm <sup>2</sup> )                      | R Rear: 150.81 psi (10.6 kg/cm <sup>2</sup> )<br>L Rear: 130.61 psi (9.18 kg/ cm <sup>2</sup> ) |
| Ingress Protection Code   | IPX3  |   |
| Sound Pressure Level<br>(IEC 60704-1) (AXP)   | 65 dB(A) (3.0 dB(A) uncertainty) Sound and Vibration Report         |   |
| Vibrations at the Hand Controls (ISO 5349-1)  | .22m/s <sup>2</sup> (.044 m/s <sup>2</sup> uncertainty)             |   |
| Vibrations at the Seat (EN 1032)  | .02m/s <sup>2</sup> (.004 m/s <sup>2</sup> uncertainty)             |   |
| Gradeability  | Transport:  | 16 percent      9 degrees   |
|   | Cleaning:   | 9 percent      5 degrees  |

### Battery Compartment Dimensions

Maximum Battery Compartment

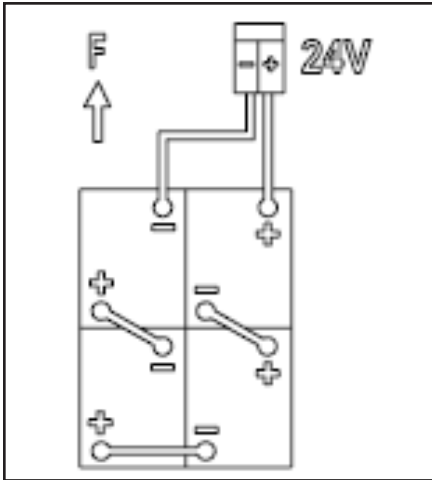

with box: 25" L X 15.5" W X 21" H

without the box: 26.25" X 16" X 21"

### Minimum Aisle Turn Around Radius (turning left)

|          |                      |
|----------|----------------------|
| 28" deck | 62.5 inches (1.59 m) |
|----------|----------------------|

### Minimum Door Pass-Thru Width

|                     |                              |
|---------------------|------------------------------|
| 28" deck (AXP & ST) | 31.5 inches (.80 m) ENG 1825 |
|---------------------|------------------------------|

# Chassis System

## Functional Description—Main Components

The chassis system consists of :

- Main machine frame
- Deck Lift Actuator assembly (See Scrub System)
- Shoe Lift Actuator assembly (See Recovery Ssystem)
- Drive Wheel assembly and Rear Wheel assembly (See Wheel System, Traction and Non-Traction)
- Lower WET/DRY/ACCESSORY attachment (See Recovery System)
- Vacuum Shoes (See Recovery System)

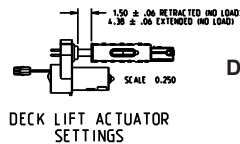

Deck Lift Actuator settings

Shoe Lift Actuator Settings

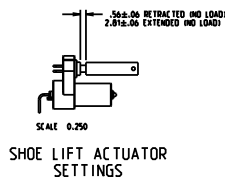

Rear Wheel assembly

Main Frame (Chassis)

Vacuum Shoes

Drive Wheel

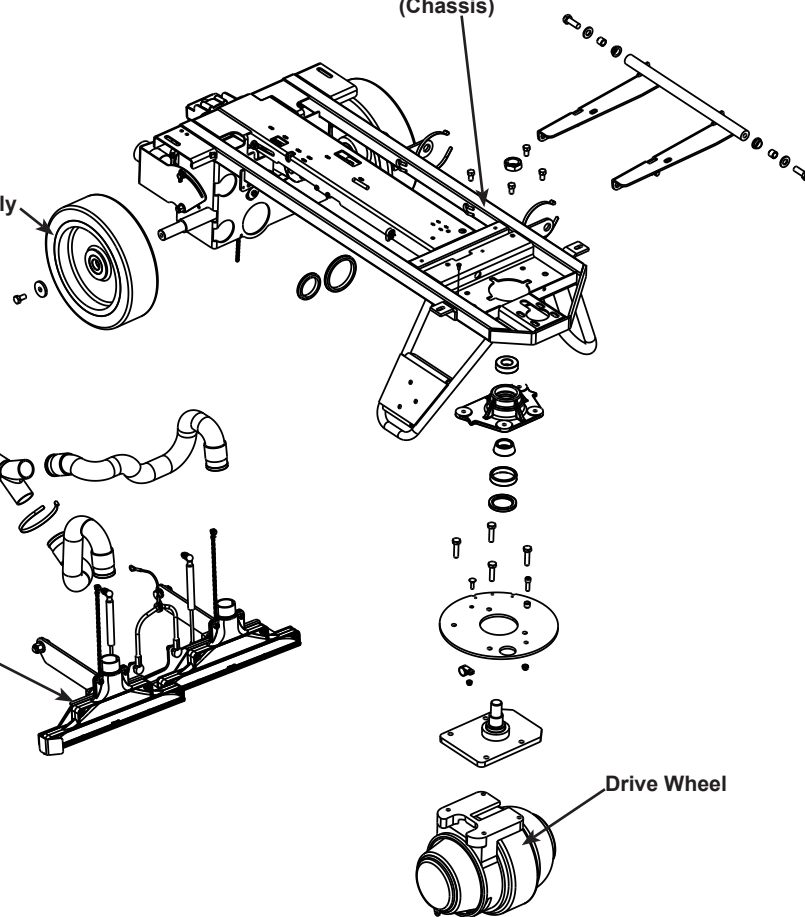

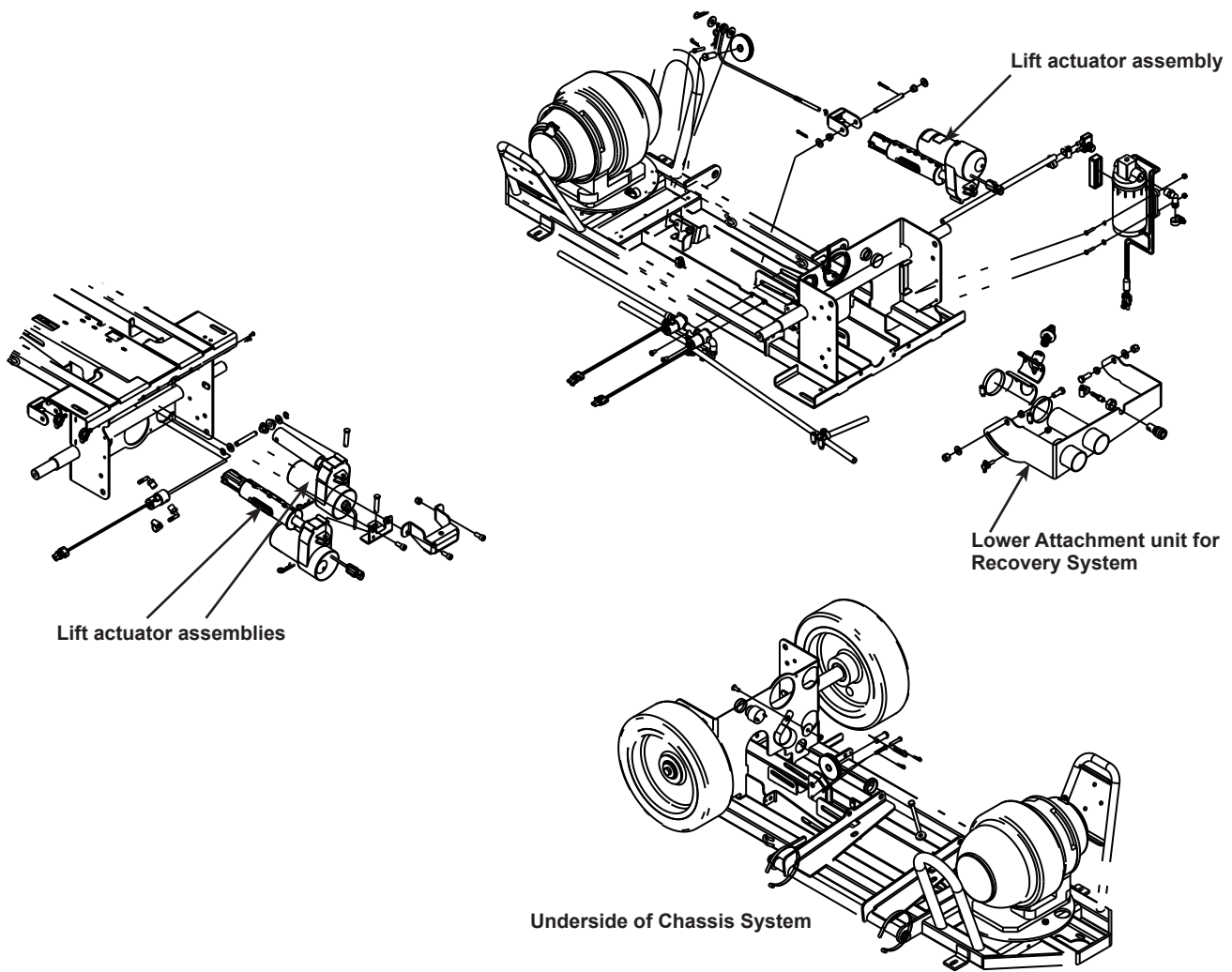

Reference these sections of this manual for more details about the various parts of the Chassis System:

- Electrical Section—all other electrical functions for entire machine.
- Recovery System for lower attachment unit, Vacuum Shoe functions, and Shoe Lift Actuator
- Wheel System, Traction and Non-Traction for Drive Wheel assembly and Rear Wheel assembly functions and maintenance
- Scrub System for Deck Lift Actuator functions and maintenance

## Control System

### Functional Description

The Control System consists of the Main Controller, Speed Controller and Operator's Control Panel.

The Main Controller operates the floor cleaning functions of the machine based on inputs from the operator and other programmed inputs.

The Speed controller controls the speed of the machine as the operator presses the drive pedal.

The Operator's Control Panel is where the driver controls all the machine cleaning functions.

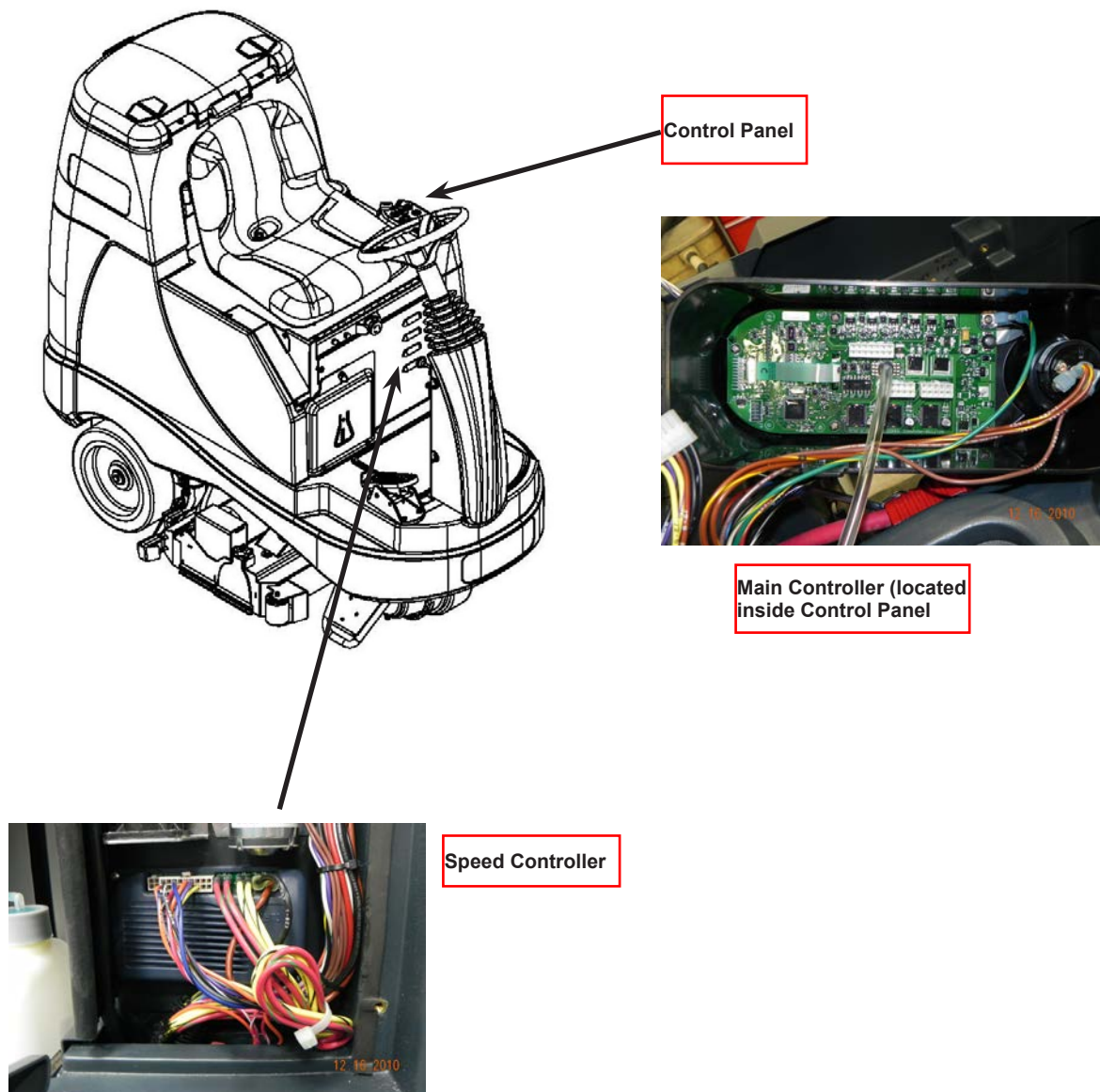

### Control System Circuit Descriptions

The main controller is directly wired to battery negative with five wires. Positive battery voltage is supplied directly to terminals J3-1 and J3-8. When the key is turned on, power is supplied to J3-14 to “wake up” the main controller. Power is also supplied through the emergency stop switch and the seat switch to let the main controller know that it is safe to operate the machine.

Some machines are equipped with an optional onboard battery charger. The battery charger has an internal “interlock” relay that prevents the operator from driving the machine away and pulling on the power cord when it is plugged into the electrical receptacle. When the AC power cord is NOT plugged in, battery voltage is allowed to pass through the normally closed contacts of the relay to the #2 Circuit breaker. This allows the machine to power up and work normally. When the AC power cord IS plugged in, the interlock relay energizes and opens the contacts, removing power from the #2 circuit breaker. This prevents the machine from powering up and moving.

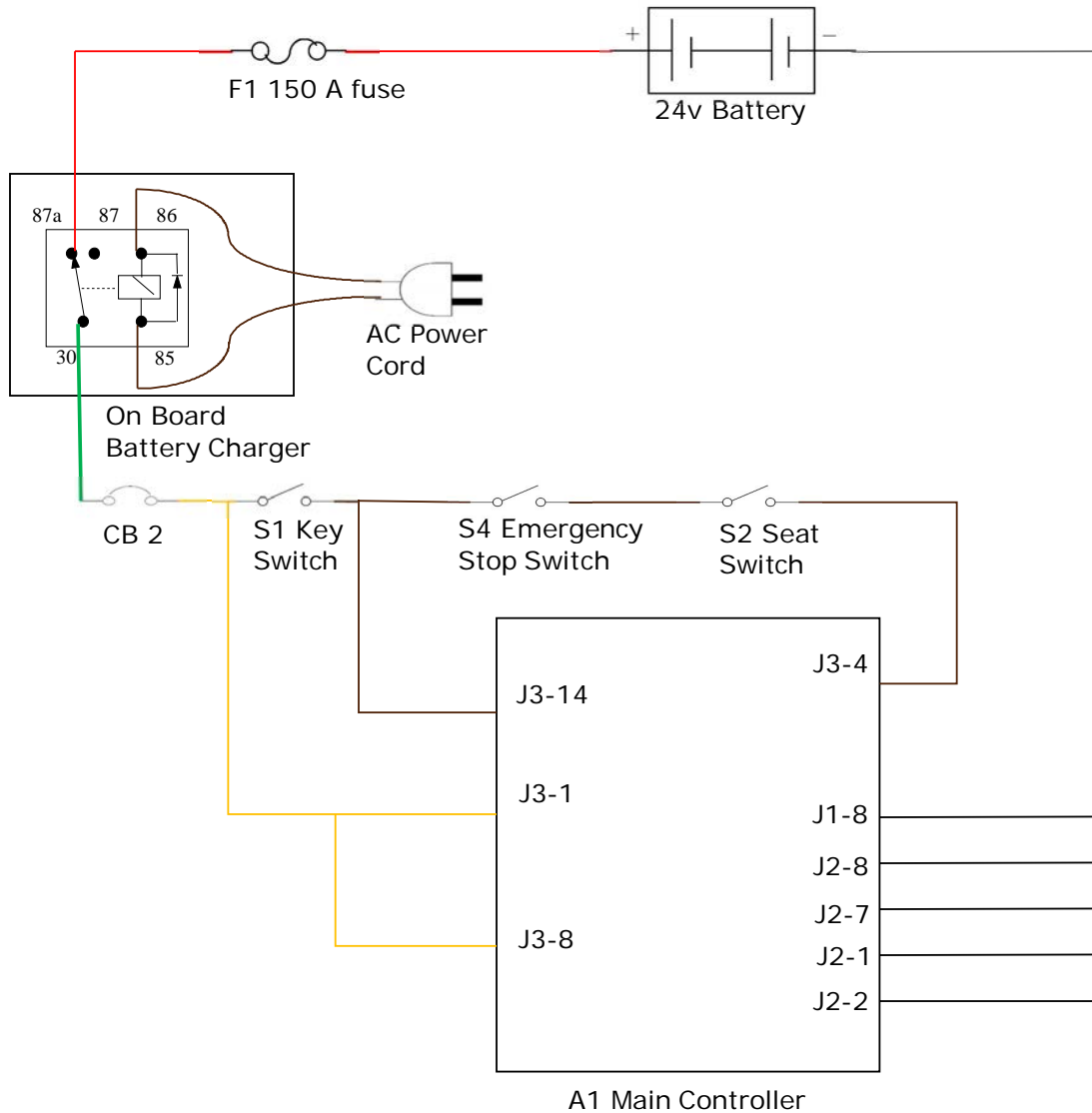

Main Controller Power Supply With Charger Unit

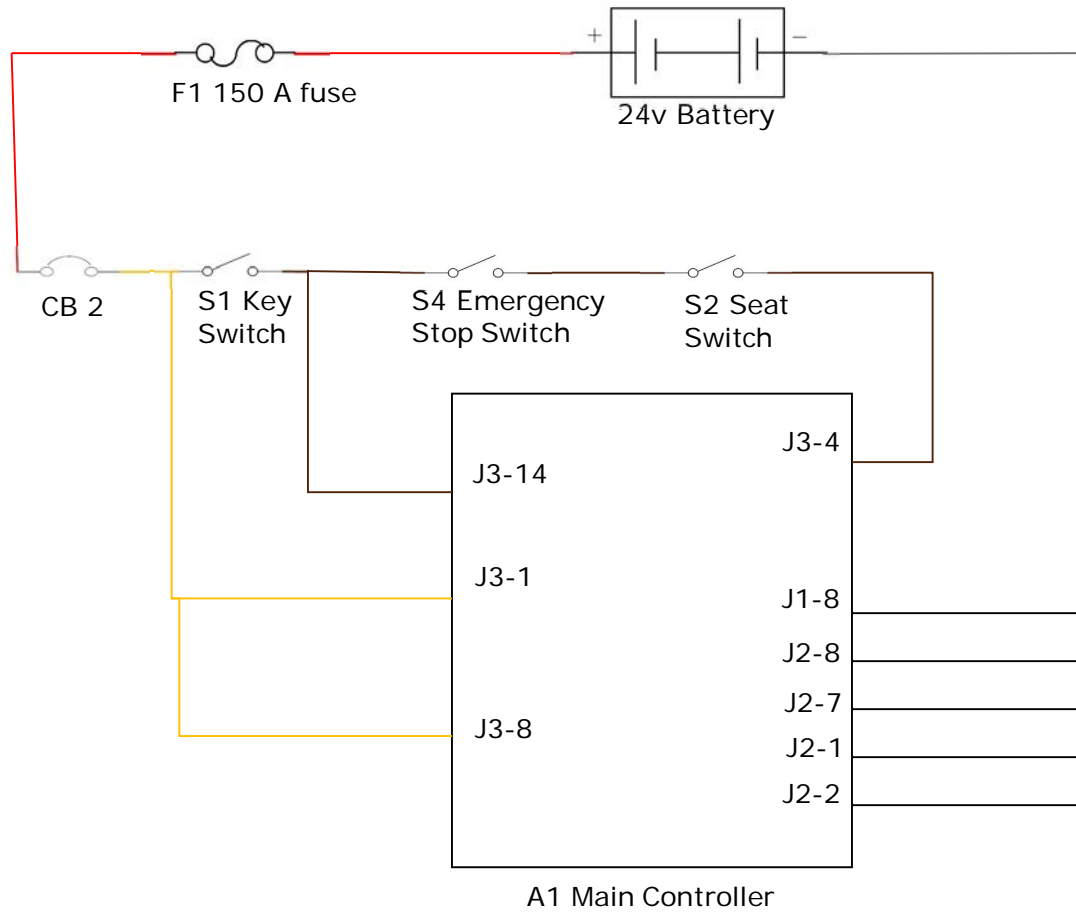

**Main Controller Power Supply Without Charger Unit**

## ***Functional Description of Main Controller***

There are two controllers on the machine, a Main Controller and a Speed Controller (see WHEEL SYSTEM, TRACTION).

The Main Controller operates the floor cleaning functions of scrub, solution and vacuum based on operator requests and other inputs. It is located directly underneath the operator control panel. It is capable of storing and displaying many fault codes. In addition to fault codes, it supports special modes of operation called “Hidden Menu” that includes “Service Test Mode”. The service test mode is a powerful and convenient diagnostic feature that allows a technician to request specific outputs to operate regardless of current inputs. Most of the other Hidden Menu contain information that tells the controller how the machine is equipped so it can operate accordingly. To access any of the Hidden Menu, refer to the section “To Change Program Option Settings” found later in this chapter.

The Drive Motor Controller (Speed Controller) operates the drive motor that propels the machine based on operator requests. (See the section “Wheel System, Traction” for more information)

## Component Locations

- Operator's Control Panel
- Main Control Board
- Speed Controller (See WHEEL SYSTEM, TRACTION)
- Battery Charger



**Main Controller**



**Battery Charger with AC power charging cord**



*Operator's Control Panel*



*Speed Controller -  
Located under Electrical  
compartment*



## Maintenance and Adjustments

### Hidden Menus

#### Program Option Settings

To change all or any one setting, perform the following steps: Use Control Panel shown for button locations.

1. Turn the main power key switch (A) to the off position.
2. Press and hold the Solution switch (B) and Vacuum switch (K) together.
3. While holding both switches, turn the main power key switch (A) to the ON position. All indicator LEDs on the Control Panel turn on.
4. Continue to hold both switches for 2 seconds until only the following indicators are still on: Interim mode LED (G), Restorative mode LED (H), PreTreat mode LED (I) & Detergent ON/OFF LED (C).
5. Release both switches. The display will now show “Program Options.”
6. To scroll through the menu use the Interim mode (G) button to scroll up (from menu 1 to 2, 2 to 3, etc) and the Restorative mode button (H) to scroll down (from menu 19 to 18, 18 to 17, etc). When you hit the top or bottom of the list, you can continue to press these buttons to roll the menus over from the last (19) to the first (1) or visa-versa.
7. To enter a sub menu press PreTreat mode (I) button
8. To change the selection within a sub menu, use the Interim mode (G) button to scroll up and the Restorative mode (H) button to scroll down through the choices.
9. To save the current choice and go back to the main menu press the Detergent ON/OFF (C) button.
10. See Figure E-10 (next page) for a list of all available categories for the top level menu.

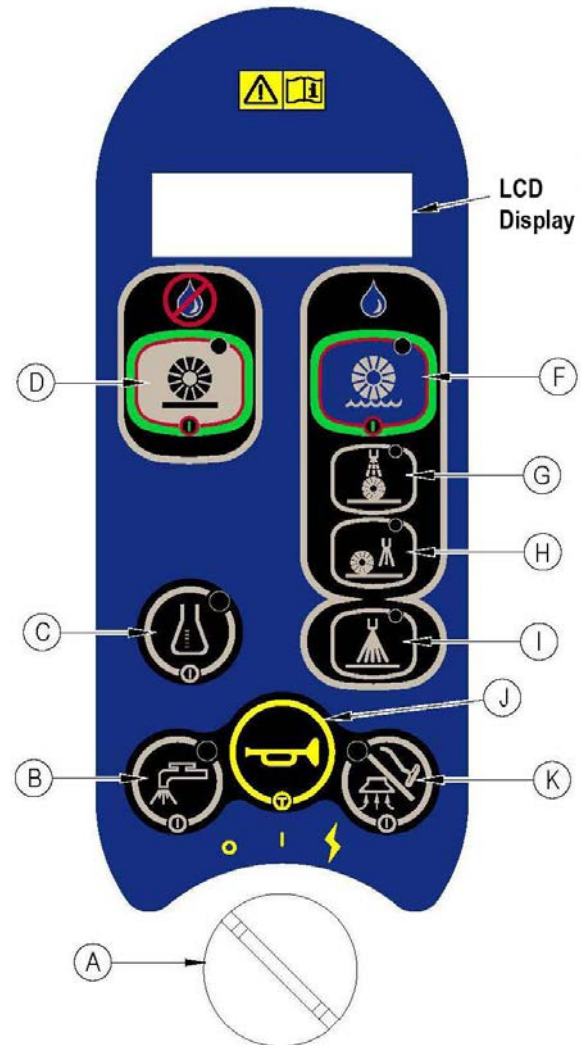

|                       |
|-----------------------|
| 1. LOW VOLTAGE CUTOUT |
| 2. MAX MAINT SPEED    |
| 3. MAX RESTORE SPEED  |
| 4. MAX PRESPRAY SPD   |
| 5. MAX SWEEP SPEED    |
| 6. RECOVERY TANK FULL |
| 7. CHEMICAL RATE BIAS |
| 8. DECK DOWN TIME     |
| 9. RESTORE DEFAULTS   |
| 10. DISPLAY REV LEVEL |
| 11. FAULT RECALL      |
| 12. FAULT DETECTION   |
| 13. SERVICE TEST MODE |
| 14. BACKUP ALARM VOL  |
| 15. FWD ALARM VOL     |
| 16. HORN VOL          |
| 17. EXTRA INFO ON LCD |
| 18. FROZEN PARAMETERS |
| 19. PANEL TEST        |

→ See 13. Service Test Mode instructions. All applicable options are identified specifically as part of the Service Test Mode.

Figure E-10 Top Level Main Options

**Low Voltage Cutout**

The Low Voltage Cutout Selection is a **MANDATORY** setting when the Main Control Board is replaced and the machine uses AGM or GEL Batteries. Default is WET BATTERY 80%.

The purpose of the special low battery voltage cutout function is to help prolong battery life. The cleaning deck will be raised and the brush motors and all solution solenoid valves and pumps will turn OFF automatically and cease to function when the batteries discharge to the selected cutout level. The cutout level is adjustable between two settings. The standard setting (wet cell/lead acid) is 20.55 volts and alternate setting (gel/maintenance free) is 21.75 volts. Figure E-11 shows the display.

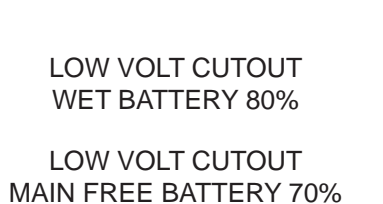

Figure E-11 Low voltage Cutout Selection Submenu Options

### Maximum Maintenance Speed

Program to limit the maximum speed while in maintenance extraction mode to a value less than that allowed for driving when not extracting (0-99% of transport speed in increments of 1%). Default is 22% OF TRANSPORT, see Figure E-12.

|                                     |
|-------------------------------------|
| Max MAINT Speed<br>95% OF TRANSPORT |
|-------------------------------------|

**Figure E-12: Maximum Maintenance Speed Submenu Options (example value shown)**

### Maximum Restore Speed

Program to limit the maximum speed while in restore extraction mode to a value less than that allowed for driving when not extracting (0-99% of transport speed in increments of 1%). Default is 1% OF TRANSPORT, see Figure E-13.

|                                       |
|---------------------------------------|
| Max RESTORE Speed<br>95% OF TRANSPORT |
|---------------------------------------|

**Figure E-13: Maximum Restore Speed Submenu Options (example value shown)**

### Maximum Prespray Speed

Program to limit the maximum speed while in prespray extraction mode to a value less than that allowed for driving when not extracting (0-99% of transport speed in increments of 1%). Default is 58% OF TRANSPORT, see Figure E-14.

|                                      |
|--------------------------------------|
| Max PRESPRAY Spd<br>95% OF TRANSPORT |
|--------------------------------------|

**Figure E-14: Maximum Prespray Speed Submenu Options (example value shown)**

### Maximum Sweep Speed

Program to limit the maximum speed while in dry sweep mode to a value less than that allowed for driving when not sweeping (0-100% of transport speed in increments of 1%). Default 65% OF TRANSPORT, see Figure E-15.

|                                      |
|--------------------------------------|
| MAX SWEEP SPEED<br>100% OF TRANSPORT |
|--------------------------------------|

**Figure E-15: Maximum Sweep Speed Submenu Options (example value shown)**

### Recovery Tank Full Enable/Disable

Enable or disable Recovery Tank Full automatic shutoff feature. Enable means that the automatic shutoff feature is turned on; disable means that the automatic shutoff feature is turned off. Default is 1.ENABLED, see Figure E-16.

|                                  |
|----------------------------------|
| RECOVERY TANK FULL<br>1. ENABLED |
|----------------------------------|

RECOVERY TANK FULL  
2.DISABLED

Figure E-16: Recovery Tank Full Enable/Disable Submenu Options

**Chemical Ratio Bias:**

The main controller can be programmed to increase or decrease the chemical mix rate by 10% to achieve a more or less concentrated mix than that determined by the user programmed ratio. Selection of a value other than “none” will adjust the delay time between voltage pulses sent to the chemical pump to accomplish a richer or leaner mixture. Default is 1. NONE, see Figure E-17.

|  |
|--|
| CHEMICAL BIAS<br>1. NONE               |
| CHEMICAL BIAS<br>2. +10% MORE CHEMICAL |
| CHEMICAL BIAS<br>3. -10% LESS CHEMICAL |

Figure E-17: Chemical Ratio Bias Submenu Options

**Deck Down Time Period Adjustment:**

When either the extraction or sweep button is pressed, the control unit will automatically lower the brush deck for a specified period prior to the deck being automatically adjusted to maintain a specific pressure on the brushes. The time that the deck is lowered is adjustable from 1 second to 5 seconds in 0.1 second increments. However, it is highly recommended that the default value of 2.5 be used to avoid over-current errors on the brush motors. Default is DECK DOWN TIME - 2.5 SECONDS, see Figure E-18.

|                               |
|-------------------------------|
| Deck Down Time<br>2.5 Seconds |
|-------------------------------|

Figure E-18: Deck Down Time Submenu (example value shown)

**Restore (Factory) Defaults**

This submenu should reset all parameters stored in the EEPROM except Brush On Time. Default is 1. NO, see Figure E-19.

|                                    |
|------------------------------------|
| RESTORE FACTORY DEFAULTS<br>1. NO  |
| RESTORE FACTORY DEFAULTS<br>2. YES |

Figure E-19: Restore Factory Defaults Submenu Options

### Display Revision Level

The LCD display will show the revision level of the software in the control board. Default is REV. C but may change with new software updates, see Figure E-20.

|                          |
|--------------------------|
| REVISION LEVEL<br>REV. C |
|--------------------------|

**Figure E-20: Restore Factory Defaults Submenu Options (example value shown)**

### Fault Recall

Whenever the control unit detects an electrical system fault, one or more error codes are displayed and stored in the EEPROM. If it is desired, the error codes (if any) from the previous operation for the machine can be recalled for troubleshooting purposes.

- If no fault code is present, the display should show a “-“
- If the Restorative button is pressed in the Fault Recall submenu the fault history shall be erased and after a few seconds the display will show “-“ to confirm the erase.

**In addition to clearing the logged fault codes, all saved data in the “Frozen Parameters” section will be erased. See section 8.19 for more information. See Figure E-21 for an example of a Fault Recall submenu.**

|                         |
|-------------------------|
| FAULT RECALL<br>3 10 32 |
|-------------------------|

**Figure E-21: Fault Recall Submenu with faults 3, 10, and 32**

### Fault Detection

Normally, the main control unit will perform checks of the electrical system during operation. If a fault occurs in a particular system, that system (and possibly others) will be shut down. This can make troubleshooting the system difficult. This option will allow service personnel to disable some of the fault detection checks to facilitate troubleshooting. This will not disable the over-current protection on any of the systems. The default value as shipped from the factory is “DISABLED”, see Figure E-22.

|                                |
|--------------------------------|
| FAULT DETECTION<br>1. ENABLED  |
| FAULT DETECTION<br>2. DISABLED |

**Figure E-22: Fault Detection Submenu Options**

## Service Test Mode

The Service Test Mode is one of the top level Hidden Menus. Due to the value of these options, and to you the technician, the instructions are elevated to a separate level of importance. Each option is identified as part of the Service Test Mode when relevant.

To assist in the troubleshooting and servicing of the electrical system and related components on the ES4000 extractors, a special test mode allows independent control of the various outputs and monitoring of various inputs. Some outputs (like the scrub brush motors) are only turned on when other conditions are met, such as when the machine is moving. It can be difficult to check for voltage to the scrub brush motors while the machine is moving. Also, if voltage is not present, the question is what other conditions may not have been met yet. The Service Test Mode solves these problems for the technician. In Service Test Mode the technician can request that the Main Machine Controller ignore all other conditions and directly turn on the scrub brush motors as well as other outputs. Service Test mode can also be used to verify that certain inputs are seen by the controller.

Use Control Panel image for button locations.

To enter the service test mode perform the following steps: (steps 1-5 are the same for entering the Hidden Menus but repeated here for your convenience. Steps 6-8 are specific to Service Test Mode).

1. Turn the main power key switch (A) to the off position.
2. Press and hold the Solution switch (B) and Vacuum switch (K) together.
3. While holding both switches, turn the main power key switch (A) to the ON position. All LED indicators on the Control Panel turn on.
4. Continue to hold both switches for 2 seconds until only the following indicators are still on: Interim Mode LED (G), Restorative mode LED (H), PreTreat mode LED (I) & Detergent ON/OFF LED (C).
5. Release both switches. The display will now show “Programming Options”
6. Scroll through the menu using the Interim Mode (G) button to scroll up (from menu 1 to 2, 2 to 3, etc) or the Restorative Mode button (H) to scroll down (from menu 19 to 18, 18 to 17, etc) until you see “13. Service Test Mode.”
7. To enter, press PreTreat mode (I) button
8. After you enter “Service Test Mode” the only way to exit from it is to turn OFF the Key Switch.

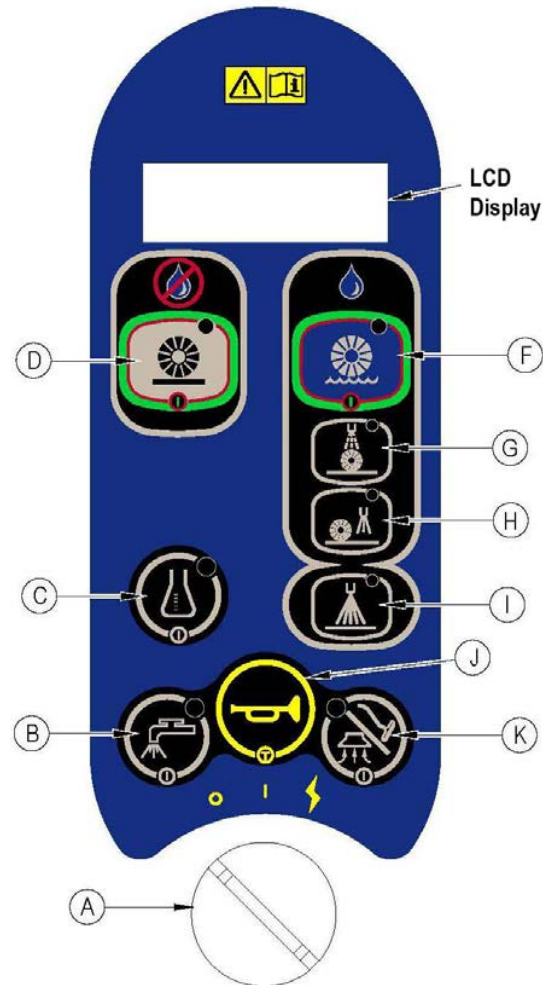

### How to Read the Battery Voltage—Using the Battery Display

The status display will show the battery voltage in the upper left corner of the panel display. This display is accurate to within +/- 0.15 volts. Therefore, the voltage displayed may not correlate precisely to a high-accuracy, calibrated voltmeter.

|       |   |      |   |      |   |
|-------|---|------|---|------|---|
| 25.16 |   | 37   |   | BAC: |   |
| SPD:  | N | MSL: | X | SAC: |   |
| BRU:  | X | RSL: |   | SP:  |   |
| VAC:  |   | MST: |   | CP:  | X |

If over-current faults are present, the status display will indicate the error codes in the upper center of the display. If more than one error is present, the display will cycle through them every second.

### Control Panel Switch Functions

See Control Panel image for button locations. The control panel switches are used in the Service Test Mode to control various output functions of the main control unit. Below is a list of each switch and the function it controls. Pressing a button more than once will toggle through the available states. A detailed description of each function follows.

- Wet Mode switch (F): Controls **shoe lift actuator** (toggle between OFF, Down and Up).
- Interim mode switch (G): Controls **maintenance solenoid** (ON/OFF).
- Restorative mode switch (H): Controls the **restore solenoid** (ON/OFF).
- Vacuum ON/OFF switch (K): Controls vacuum **motor contactor** (ON/OFF).
- Solution ON/OFF switch (B): Controls **solution pump** (ON/OFF).
- Horn switch (J): Controls **brush motors contactor** (ON/OFF).
- Detergent ON/OFF switch (C): Controls the **chemical detergent pump** (ON/OFF).
- PreTreat mode ON/OFF switch (I): Controls **misting solenoid** (ON/OFF).
- Dry Mode (D) switch: Controls **brush deck lift actuator** (toggle between Down and Up)

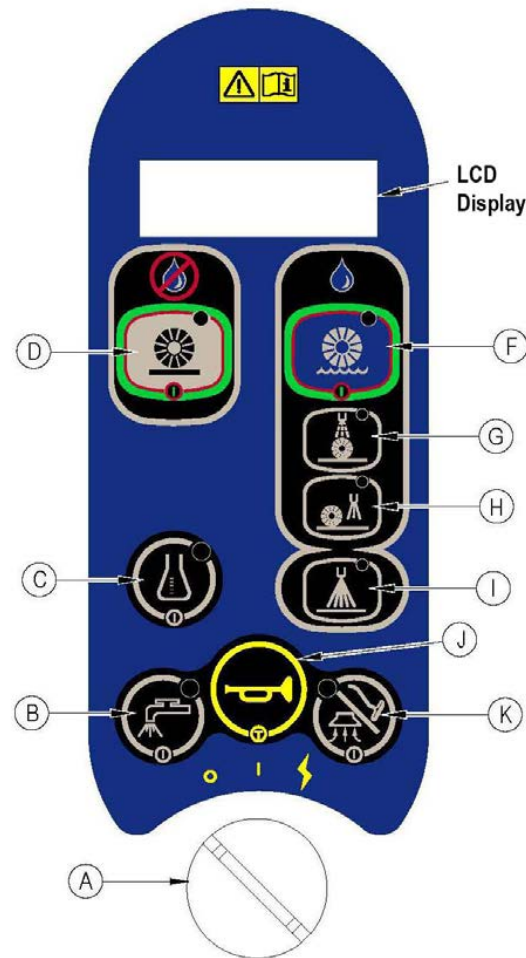

**Control Panel LCD Information in Service Test Mode**

The Control Panel LCD shows various information. Each item has an Acronym or display code to describe the state of the Service Test Mode. See Figure E-23 and E-23a for position of data on LCD.

- **25.31**: Display actual battery voltage
- **SPD** (Speed Controller): N (Neutral), F (Forward), R (Reverse)
- **BRU** (Brush Contactor): blank (OFF) or X (ON)
- **VAC** (Vacuum Contactor): blank (OFF) or X (ON)
- **37**: Error code or “00” if there are no faults (37 is an example for demonstration)
- **MSL** (Maintenance solenoid): blank (OFF) or X (ON)
- **RSL** (Restore solenoid): blank (OFF) or X (ON)
- **MST** (Mist solenoid): blank (OFF) or X (ON)
- **BAC** (Brush Actuator): blank (OFF), U (Up), or D (Down)
- **SAC** (Shoe Actuator): blank (OFF), U (Up), or D (Down)
- **SP** (Solution Pump): blank (OFF) or “X” (ON)
- **CP** (Chemical Pump): blank (OFF) or “X” (ON)



Figure E-23

*Note: In Figure E-23a below, an example screen shows the speed control in Neutral, Brush Contactor on, Maintenance Solenoid on, and Chemical Pump on. One error code is also present, CODE 37.*

|       |   |      |   |       |
|-------|---|------|---|-------|
| 25.31 |   | 37   |   | BAC:  |
| SPD:  | N | MSL: | X | SAC:  |
| BRU:  | X | RSL: |   | SP:   |
| VAC:  |   | MST: |   | CP: X |

Figure E-23a

**SERVICE TEST MODE instructions end here.**

### Backup Alarm Volume

The backup alarm is variable. Set the back up alarm volume in the hidden menu to: Off, Low, Medium and High. Figure E-24.

|                               |
|-------------------------------|
| BACKUP ALARM VOL<br>1. OFF    |
| BACKUP ALARM VOL<br>2. LOW    |
| BACKUP ALARM VOL<br>3. MEDIUM |
| BACKUP ALARM VOL<br>4. HIGH   |

Figure E-24: Backup Alarm Volume Display

### Forward Alarm Volume

The forward annunciation volume is variable using the hidden menu. Set the volume to one of the available levels: Off, Low, Medium and High. Figure E-25.

|                            |
|----------------------------|
| FWD ALARM VOL<br>1. OFF    |
| FWD ALARM VOL<br>2. LOW    |
| FWD ALARM VOL<br>3. MEDIUM |
| FWD ALARM VOL<br>4. HIGH   |

Figure E-25: Forward Alarm Volume Display

### Horn Volume

The horn is adjustable to various levels using the hidden menu. Set the Horn volume to one of the available levels: Off, Low, Medium and High. Figure E-26.

|                          |
|--------------------------|
| HORN VOLUME<br>1. OFF    |
| HORN VOLUME<br>2. LOW    |
| HORN VOLUME<br>3. MEDIUM |
| HORN VOLUME<br>4. HIGH   |

Figure E-26: Horn Volume Display

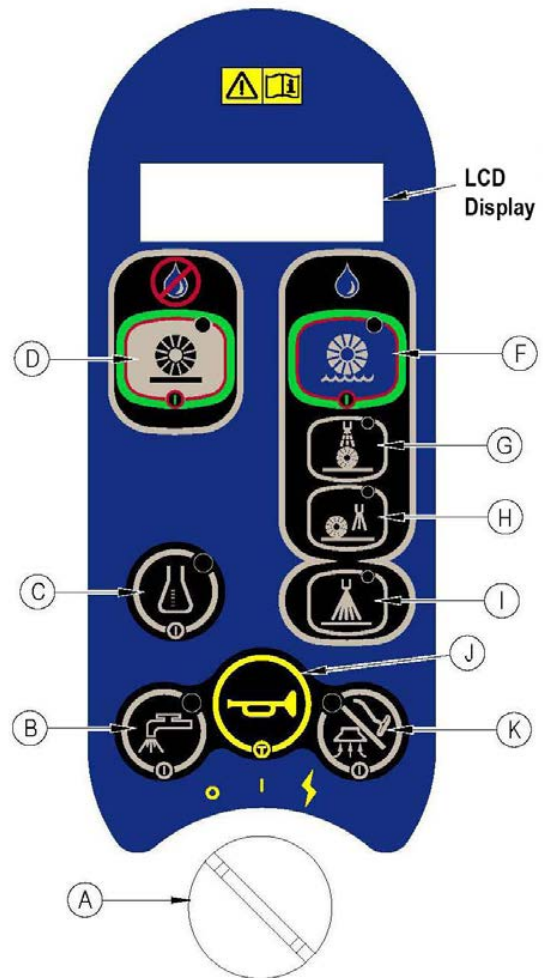

**Extra Info on LCD**

This screen selects the extra information that can be displayed real-time on the LCD. This aids in troubleshooting the machine in normal operation. The default is to display no extra info. If extra information is selected for display, a 2-letter or 3-letter code is displayed to identify the information, while underneath the code is a number. The number indicates a value in amps, volts, or is without a unit designation depending upon what is selected. Only one piece of extra information can be displayed at any time, but the selected information can be changed at will via the hidden menu. Press DETERGENT button to back out of the menu and save the selection. Cycle the Key Switch to return to normal operations mode. A summary of the identification codes shown on the LCD display is as follows:

- BV = Battery Voltage
- LOK = Battery Lock Level
- FBR, RBR = Front/Rear Brush Motor Current (Instantaneous or Average)
- VAC = Vacuum Motor Current (the sum of two vac motors)
- MSO, RSO = Maintenance Solenoid Current & Restore Solenoid Current
- MST = Misting Solenoid Current
- BCO, VCO = Brush Contactor Current, Vacuum Contactor Current
- BAC, SAC = Brush Actuator Current & Shoe Actuator Current
- CP, SP = Chemical Pump Current & Solution Pump Current
- HRS = Brush On-Time Hourmeter

See Figure E-27 for a list of all available info that can be selected for display.

|   |   |
|---|---|
| EXTRA INFO ON LCD<br>1. NONE              |   |
| EXTRA INFO ON LCD<br>2. BATT VOLTS        | 2. Battery Voltage (volts)                            |
| EXTRA INFO ON LCD<br>3. BATT LOCK VALUE   | 3. Battery Lock Value (no units)                      |
| EXTRA INFO ON LCD<br>4. FR AVG BRUSH CURR | 4. Front average brush current (amps)                 |
| EXTRA INFO ON LCD<br>5. RR AVG BRUSH CURR | 5. Rear average brush current (amps)                  |
| EXTRA INFO ON LCD<br>6. VAC MOTOR CURR    | 6. Vacuum motor current (total of both motors) (amps) |
| EXTRA INFO ON LCD<br>7. MAINT SOL CURR    | 7 Maintenance solenoid current (amps)                 |
| EXTRA INFO ON LCD<br>8. REST SOL CURR     | 8. Restore solenoid current (amps)                    |
| EXTRA INFO ON LCD<br>9. MIST SOL CURR     | 9. Misting solenoid current (amps)                    |
| EXTRA INFO ON LCD<br>10. BRUSH CONT CURR  | 10. Brush contactor current (amps)                    |
| EXTRA INFO ON LCD<br>11. VAC CONT CURR    | 11. Vacuum contactor current (amps)                   |

|   |   |
|---|---|
| EXTRA INFO ON LCD<br>12. BRUSH ACT CURR   | 12. Brush actuator current (amps)   |
| EXTRA INFO ON LCD<br>13. SHOE ACT CURR    | 13. Shoe actuator current (amps)  |
| EXTRA INFO ON LCD<br>14. CHEM PUMP CURR   | 14. Chemical pump current (amps)  |
| EXTRA INFO ON LCD<br>15. SOLN PUMP CURR   | 15. Solution pump current (amps)  |
| EXTRA INFO ON LCD<br>16. ALT AVG BR CURR  | 16. Alternate every 5 seconds between front and rear average brush current (amps)       |
| EXTRA INFO ON LCD<br>17. ALT INST BR CURR | 17. Alternate every 5 seconds between front and rear instantaneous brush current (amps) |
| EXTRA INFO ON LCD<br>18. FR INST BR CURR  | 18. Front instantaneous brush current (amps)  |
| EXTRA INFO ON LCD<br>19. RR INST BR CURR  | 19. Rear instantaneous brush current (amps)   |
| EXTRA INFO ON LCD<br>20. BRUSH HOURS      | 20. Brush hour meter (hours)  |

The instantaneous views are preferred over the alternating views since they show what the brushes are doing in real time.

Figure E-27: Diagnostic Mode Selection Display

**Frozen Parameters**

This screen is used to view all of the internal parameters that were saved or “frozen” when the 1<sup>st</sup> error code was detected. Nine different parameters are logged, and all but two are saved at 100 msec intervals for 6.4 seconds leading up to the error code. The first viewable parameter is the error code that actually initiated the freezing of parameter values. The second viewable parameter is the hour meter value at the time of the frozen error code. If no error code occurred, then the stored data will all be blank (all zeroes). Examples of the main menu and sub-menus are shown in figures E-29 and E-30. In the Sub-menus, data point #1 is the newest value and #64 is the oldest value (that occurred 6.3 seconds earlier).

There are 2 levels of sub-menus for this top-level menu. In the first sub-menu you select the category of parameter to view by choosing 1 of the 9 categories listed in Figure E-28. For most categories there is a second sub-menu in which you select the specific value in history to view (data point 1 through 64). See figures E-29 and E-30 for examples of submenus. Keypad navigation is the same for each level, so the following set of 3 rules applies to each level:

1. To scroll through the menu use the Interim mode button (G) to scroll up and the Restorative mode (H) button to scroll down. See Control Panel Image for button locations.
2. To enter a sub-menu press the PreTreat button (I). If no

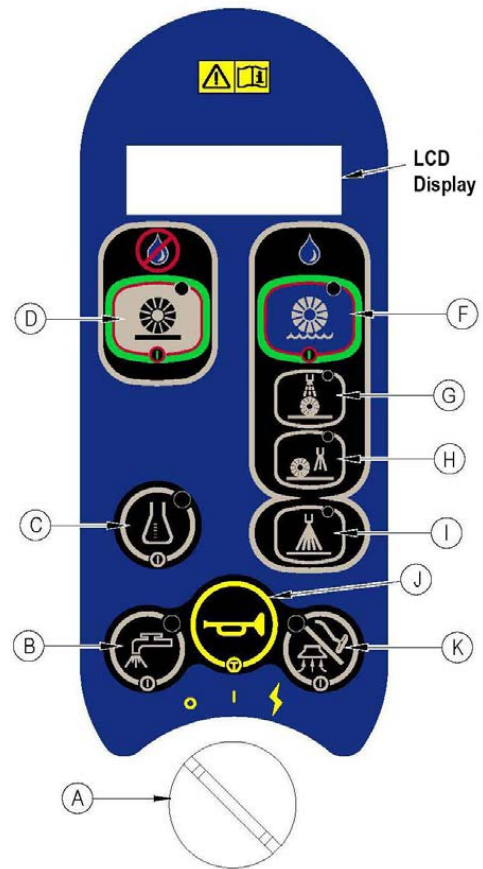

further sub-menus exist then this button has no effect.

- To go back one level in the menus press the Detergent button (C).

There is one additional feature that is available only when you enter into the 2<sup>nd</sup> level of menus. This feature automatically turns on and off when you enter or leave a 2<sup>nd</sup>-level menu:

Upon entering any 1st-level menu, the LED on the Vacuum ON/OFF (K) button will turn on to indicate that this button can be used. Pressing this button in any 1st-level function has no effect, but after entering the 2nd level menu a press of this button will toggle between fast and slow increment modes when you are scrolling through the 64 available data points for each logged parameter.

In slow mode the increment/decrement value is 1, so that pressing the Interim mode (G) button will cycle you from data record 1 to 2, 2 to 3, etc, and pressing the Restorative button will cycle you from data record 64 to 63, 63 to 62, etc.

In fast mode the increment/decrement value is 10, so that pressing the Interim button will cycle you from data record 10 to 20, 20 to 30, etc, and pressing the Restorative button will cycle you from data record 60 to 50, 50 to 40, etc. The purpose of this feature is to reduce the number of button presses required to cycle through all 64 data records should you choose to do so. Use of this feature will automatically end when you press the Detergent button (C) to leave a 2nd-level menu, and the Vacuum button LED will turn off when you press the Detergent button (C) again to leave the 1st-level menu.

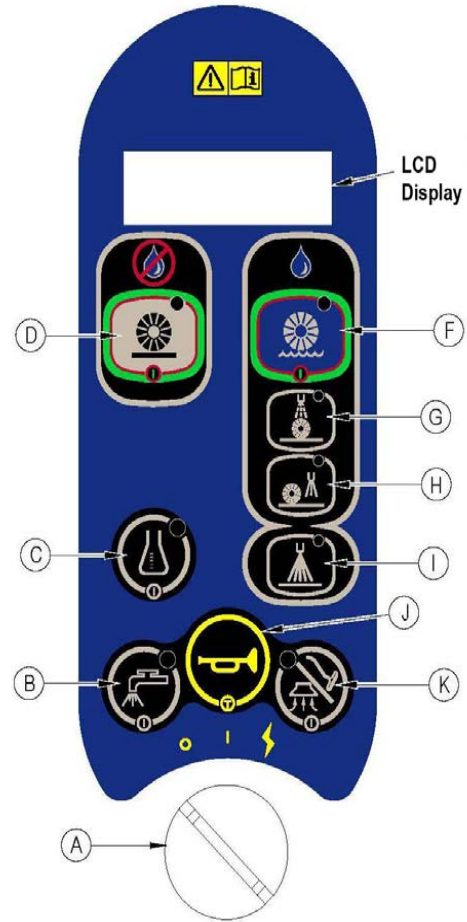

*Note: Error codes will remain even after an error occurrence has been corrected. Clear error codes using the Fault Recall menu.*

|                                       |  |
|---------------------------------------|--|
| FROZEN PARAMETERS<br>1.ERROR CODE     | 1. Error code  |
| FROZEN PARAMETERS<br>2.HOUR METER     | 2. Hour meter  |
| FROZEN PARAMETERS<br>3.BATT VOLTAGE   | 3. Battery Voltage                                       |
| FROZEN PARAMETERS<br>4.F BRUSH CURR   | 4. Front brush current                                   |
| FROZEN PARAMETERS<br>5.VAC MTR CURR   | 5. Vacuum motor current                                  |
| FROZEN PARAMETERS<br>6.R BRUSH CURR   | 6. Rear brush current                                    |
| FROZEN PARAMETERS<br>7.SHOE ACT CURR  | 7. Shoe actuator current                                 |
| FROZEN PARAMETERS<br>8.BRUSH ACT CURR | 8. Brush actuator current                                |
|                                       | 9. Machine mode of operation (Transport, Extract, Sweep) |

**Figure E-28: Frozen Parameters Display**

FROZEN PARAMETERS  
9.MODE

FROZEN PARAMETERS  
1.ERROR CODE  
37

Figure E-29: Error Code Sub-Menu Example

FROZEN PARAMETERS  
3.BATT VOLTAGE  
64: 24.56

Figure E-30: Battery Voltage Sub-Menu Example—Data Record #64 for the Battery Voltage reads 24.56 Volts

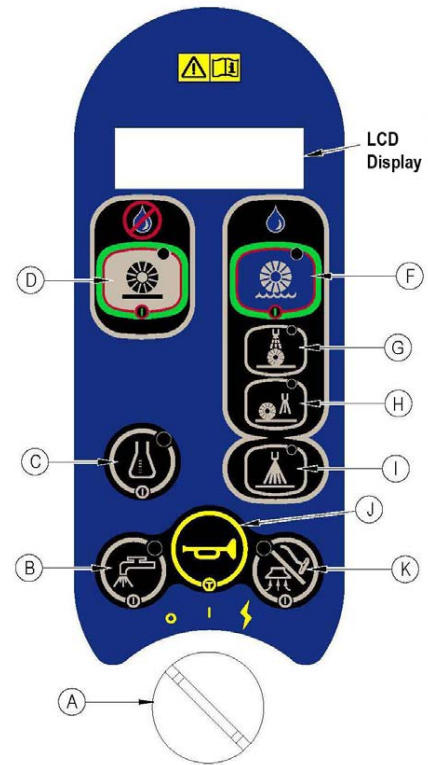

**Panel Test**

This Hidden Menu screen is used for identifying intermittent membrane buttons and LEDs and to verify that they all function properly.

- In this mode the button that has been pressed will be displayed on the line below “PANEL TEST.”
- The corresponding green LED for the button is also turned on. All buttons except the Horn button (J) have an associated green LED. When the Horn button is pressed, both the yellow “Sweep” LED (D) and the yellow “Extract” LED (F) will turn on. In this way it is possible to test all 10 LEDs and all 9 membrane buttons from this menu.
- Identification of the button and the corresponding LED will occur as soon as the button is pressed down. The display and LED will stay in that state until a different button is pressed.
- Each button will have its own button counter. When you press a button, the corresponding counter will be displayed on the bottom line of the LCD. Each button press will increment the counter until it hits 255, after which the counter will roll over to 0. The purpose of the counter is to allow you to compare the number of detected button presses to the number of times you actually pressed the button. This may help you to determine if the button is working correctly or if it is intermittent.
- After this menu is entered, the only way to exit is by cycling the key switch.
- See Figure E-31 for an example of an LCD screen that shows the Detergent button (C) pressed with 14 counts so far.

PANEL TEST  
CHEMICAL  
14

Figure E-31: Button Test Sub-Menu Example

## Troubleshooting

### Fault Codes

Any error codes detected by the main control board will be displayed on the LCD as they occur. If more than one error exists the display will sequence through the error codes at one-second intervals. The error will display as a mechanical wrench symbol followed by a two-digit code. EX:03 would be a speed control fault. Error codes 30 – 41 (open circuit detection for various loads) are enabled and disabled via the Hidden Menu setting for “Fault Detection”. Only this set of 12 error codes can be disabled.

| LCD Display Code | Code Definition                               | Explanation / Code Setting Conditions / Flash Indicator Disables / Check / Thresholds  |
|------------------|---|--|
| 03               | Speed Control Fault                           | The Drive Controller is communicating that it has a fault code stored. Count the number of flashes of the Detergent button LED to identify the specific fault code, and then check the specific code in the Drive System Controller. |
| 04               | Scrub Deck Lift Actuator Circuit Over Current | Excessive current draw was sensed. Code sets at approximately 3.7 amps or more.<br>Check for shorted actuator, mechanical binding of actuator linkage, shorted wiring.   |
| 05               | Front Brush Motor Circuit Over Current        | Excessive current draw was sensed. Code sets at approximately 19.8 amps or more.<br>Check for shorted motor, mechanical binding of motor shaft, current sense wire connections, ground connections.                                  |
| 06               | Shoe Lift Actuator Over Current               | Excessive current draw was sensed. Code sets at approximately 3.7 amps or more.<br>Check for shorted actuator, mechanical binding of actuator linkage, shorted wiring.   |
| 07               | Vacuum Motor Circuit Over Current             | Excessive current draw was sensed. Code sets at approximately 68 amps or more. Check for shorted motor, current sense wire connections, ground connections, on either or both motors.  |
| 08               | Maintenance Solenoid Circuit Over Current     | Excessive current draw was sensed. Code sets at approximately 0.62 amps or more. Check for shorted solenoid winding, shorted wiring  |
| 09               | Vacuum Contactor Coil Circuit Over Current    | Excessive current draw was sensed. Code sets at approximately 0.89 amps or more. Check for shorted contactor winding, shorted wiring.  |
| 10               | Brush Contactor Coil Circuit Over Current     | Excessive current draw was sensed. Code sets at approximately 0.89 amps or more. Check for shorted contactor winding, shorted wiring   |
| 11               | Detergent Pump Circuit Over Current           | Excessive current draw was sensed. Code sets at approx. 2.9A or more. Check for shorted pump winding, shorted wiring   |
| 12               | Solution Pump Over Current                    | Excessive current draw was sensed. Code sets at approx. 4.3A or more. Check for shorted pump winding, shorted wiring   |
| 13               | Restore Solenoid Over Current                 | Excessive current draw was sensed. Code sets at approx. 4.3A or more. Check for shorted solenoid winding, shorted wiring.  |
| 14               | Misting Solenoid Over Current                 | Excessive current draw was sensed. Code sets at approx. 0.62A or more. Check for shorted solenoid winding, shorted wiring  |

| LCD Display Code | Code Definition                       | Explanation / Code Setting Conditions / Flash Indicator Disables / Check / Thresholds   |
|------------------|---------------------------------------|---|
| 15               | Rear Brush Motor Over Current         | Excessive current draw was sensed. Code sets at approx. 19.8A or more. Check for shorted motor, current sense wire connections, ground connections.   |
| 30               | Maintenance Solenoid Circuit Open     | The Main Machine Controller has turned the solution solenoid circuit on but it is not sensing any current flow. (Senses <= 20mAmps for 10 seconds).<br>Check for open solenoid winding, open wiring.  |
| 31               | Front Brush Motor Circuit Open        | The Main Machine Controller has energized the Brush Contactor but it is not sensing any current flow through the brush motor ground circuit for at least 5 seconds. (Senses <= 2 Amps for 10 seconds)<br>Check Motor, Contactor contacts, Wiring. |
| 32               | Scrub Deck Lift Actuator Circuit Open | The Main Machine Controller is trying to move the actuator but it is not sensing any current flow. (Senses <= 67 m Amps for 10 seconds)<br>Check Actuator, wiring.  |
| 33               | Vacuum Motor Circuit Open             | The Main Machine Controller has energized the Vacuum Contactor but it is not sensing any current flow through the vacuum motor ground circuit for at least 5 seconds. (Senses<= 2 Amps for 5 seconds)<br>Check motor, wiring, contactor           |
| 34               | Shoe Lift Actuator open               | The Main Machine Controller is trying to move the actuator but it is not sensing any current flow. (Senses <=67mA for 10 seconds)<br>Check Actuator, wiring   |
| 35               | Brush Contactor Coil Circuit Open     | The Main Machine Controller has attempted to energize the Brush Contactor but it is not seeing any current flow. (Senses <= 40 m Amps for 10 seconds).<br>Check for open Contactor winding, wiring  |
| 36               | Vacuum Contactor Coil Circuit Open    | The Main Machine Controller has attempted to energize the Vacuum Contactor but it is not seeing any current flow. if (Senses <= 40 m Amps for 5 seconds)<br>Check for open Contactor winding, wiring.   |
| 37               | Detergent Pump Circuit Open           | The Main Machine Controller has energized the detergent pump but it is not sensing any current flow. (Senses <= 100 m Amps for 5 seconds).<br>Check for open pump winding, wiring.  |
| 38               | Rear Brush motor Circuit Open         | The Main Machine Controller has energized the Brush Contactor but it is not sensing any current flow through the brush motor ground circuit for at least 5 seconds. (Senses <= 2 Amps for 10 seconds)<br>Check Motor, Contactor contacts, Wiring. |
| 39               | Solution Pump Open                    | The Main Machine Controller has energized the solution pump but it is not sensing any current flow. (Senses<= 150 mA for 10 seconds)<br>Check for open pump winding, wiring.  |

| LCD Display Code | Code Definition                                 | Explanation / Code Setting Conditions / Flash Indicator Disables / Check / Thresholds   |
|------------------|---|---|
| 40               | Restore Solenoid Open                           | The Main Machine Controller has turned the solution solenoid circuit on but it is not sensing any current flow ( $\leq 20\text{mA}$ for 10 seconds)<br>Check for open solenoid winding, open wiring.  |
| 41               | Misting Solenoid Open                           | The Main Machine Controller has turned the solution solenoid circuit on but it is not sensing any current flow ( $\leq 20\text{mA}$ for 10 seconds)<br>Check for open solenoid winding, open wiring.  |
| 60               | Front Brush Motor Stuck Closed                  | The Main Machine Controller is sensing current flow through the Front Brush Motor ground circuit when it has not energized the Brush Motor Contactor (Senses $\geq 2\text{Amps}$ for 10 seconds)<br>Check for a short in the harness wiring to the motor. |
| 61               | Vacuum Motor Stuck Closed                       | The Main Machine Controller is sensing current flow through the Vacuum Motor ground circuit when it has not energized the Vacuum Motor Contactor (Senses $\geq 2\text{Amps}$ for 5 seconds)<br>Check for a short in the wiring harness to the motor       |
| 62               | Maintenance Solenoid Circuit Stuck On (closed)  | The Main Machine controller is sensing current flow through its internal switch for the maintenance solenoid circuit when it has not requested that the switch be turned on. (Senses $\geq 20\text{m Amps}$ for 10 seconds).                              |
| 63               | Brush Contactor Coil Circuit Stuck On (closed)  | The Main Machine controller is sensing current flow through its internal switch for the Brush Contactor Coil circuit when it has not requested that the switch be turned on. (Senses $\geq 40\text{m Amps}$ for 10 seconds).                              |
| 64               | Vacuum Contactor Coil Circuit Stuck On (closed) | The Main Machine controller is sensing current flow through its internal switch for the Vacuum Contactor Coil circuit when it has not requested that the switch be turned on. (Senses $\geq 40\text{m Amps}$ for 5 seconds).                              |
| 65               | Restore Solenoid Stuck Closed                   | The Main Machine controller is sensing current flow through its internal switch for the restore solenoid circuit when it has not requested that the switch be turned on. (Senses $\geq 20\text{m Amps}$ for 10 seconds).                                  |
| 66               | Misting Solenoid Stuck Closed                   | The Main Machine controller is sensing current flow through its internal switch for the misting solenoid circuit when it has not requested that the switch be turned on. (Senses $\geq 20\text{m Amps}$ for 10 seconds).                                  |
| 67               | Rear Brush Motor Stuck closed                   | The Main Machine Controller is sensing current flow through the Rear Brush Motor ground circuit when it has not energized the Brush Motor Contactor (Senses $\geq 2\text{A}$ for 10 seconds).<br>Check for a short in the harness wiring to the motor.    |

Figure E-32: Fault Code Descriptions

Specific actions will happen for each electrical system fault detected. See figure E-33 for systems to be disabled for each fault code. Once any system is disabled it cannot be turned on again until key switch is cycled. Details of how each system are disabled is as follows:

1. Chemical System: Detergent LED (C) turns off (unless it is flashing due to a chem. pump fault) and chemical off icon is displayed on LCD. Chemical pump turns off.
2. Solution System: Solution LED turns off (unless it is flashing due to a solution pump fault). Solution pump turns off.
3. Extract System: Extract LED, Restore LED, Maintenance LED, and Prespray LED turn off (extract LED will flash if the fault is due to a maintenance or restore solenoid fault). Maintenance and Restore solenoids turn off. Shoe deck returns to raised position. Extract button is locked out. Hose change screens appear on LCD until user acknowledges and switches to Sweep Mode.
4. Sweep System: Sweep LED turns off. Sweep button is locked out. Hose change screens appear on LCD until user acknowledges and switches to Extract Mode.
5. Recovery System: Vacuum/Wand LED turns off (unless it is flashing due to a vacuum fault). Vacuum turns off.
6. Brush Deck: Machine should remain in its current mode (sweep or extract). Brush deck actuator turns off.
7. Brush Motors: Brushes turn off.
8. Misting Solenoid: Solenoid turns off.

*NOTE: If both the extract and sweep systems are simultaneously disabled (see chart below) then both the Extract & Sweep LEDs will flash and the LCD will revert to the normal sweep mode screen.*

|              |                                   | Disable System |          |         |       |          |            |              |                  | Flash Indicator |              |             |           |            |
|--------------|-----------------------------------|----------------|----------|---------|-------|----------|------------|--------------|------------------|-----------------|--------------|-------------|-----------|------------|
| Display Code | Fault Description                 | Chemical       | Solution | Extract | Sweep | Recovery | Brush Deck | Brush Motors | Misting Solenoid | Detergent LED   | Solution LED | Extract LED | Sweep LED | Vacuum LED |
| 3            | Speed Control Fault               | x              | x        | x       | x     |          |            | x            | x                |                 |              |             |           |            |
| 4            | Brush Deck Lift Actuator Overload |                |          | x       | x     |          | x          |              |                  |                 |              |             |           |            |
| 5            | Front Brush Motor Overload        | x              | x        | x       | x     |          | x          | x            | x                |                 |              | x           | x         |            |
| 6            | Shoe Lift Actuator Overload       | x              | x        | x       |       |          |            |              |                  |                 |              | x           |           |            |
| 7            | Vacuum Motor Overload             | x              | x        | x       | x     | x        |            |              | x                |                 |              | x           | x         | x          |

| Disable System |                                |          |          |         |       |          |            |              |                  | Flash Indicator |              |             |           |            |
|----------------|--------------------------------|----------|----------|---------|-------|----------|------------|--------------|------------------|-----------------|--------------|-------------|-----------|------------|
| Display Code   | Fault Description              | Chemical | Solution | Extract | Sweep | Recovery | Brush Deck | Brush Motors | Misting Solenoid | Detergent LED   | Solution LED | Extract LED | Sweep LED | Vacuum LED |
| 8              | Maintenance Solenoid Overload  | x        | x        | x       |       |          |            |              |                  |                 |              | x           |           |            |
| 9              | Vacuum Contactor Coil Overload | x        | x        | x       | x     | x        |            |              | x                |                 |              | x           | x         | x          |
| 10             | Brush Contactor Coil Overload  | x        | x        | x       | x     |          | x          |              | x                |                 |              | x           | x         |            |
| 11             | Chemical Pump Overload         | x        |          |         |       |          |            |              |                  | x               |              |             |           |            |
| 12             | Solution Pump Overload         | x        | x        | x       |       |          |            |              | x                |                 | x            | x           |           |            |
| 13             | Restore Solenoid Overload      | x        | x        | x       |       |          |            |              |                  |                 |              | x           |           |            |
| 14             | Misting Solenoid Overload      |          | x        |         |       |          |            |              | x                |                 |              |             |           |            |
| 15             | Rear Brush Motor Overload      | x        | x        | x       | x     |          | x          | x            | x                |                 |              | x           | x         |            |
| 30             | Maintenance Solenoid Open      | x        | x        | x       |       |          |            |              |                  |                 |              | x           |           |            |
| 31             | Front Brush motor Open         | x        | x        | x       | x     |          |            | x            | x                |                 |              | x           | x         |            |
| 32             | Brush Deck Lift Actuator Open  |          |          | x       | x     |          | x          |              |                  |                 |              |             |           |            |
| 33             | Vacuum Motor Open              | x        | x        | x       | x     | x        |            |              | x                |                 |              | x           | x         | x          |
| 34             | Shoe Lift Actuator Open        | x        | x        | x       |       |          |            |              |                  |                 |              | x           |           |            |
| 35             | Brush Contactor Coil Open      | x        | x        | x       | x     |          |            | x            | x                |                 |              | x           | x         |            |

|              |                                    | Disable System |          |         |       |          |            |              |                  | Flash Indicator |              |             |           |            |
|--------------|------------------------------------|----------------|----------|---------|-------|----------|------------|--------------|------------------|-----------------|--------------|-------------|-----------|------------|
| Display Code | Fault Description                  | Chemical       | Solution | Extract | Sweep | Recovery | Brush Deck | Brush Motors | Misting Solenoid | Detergent LED   | Solution LED | Extract LED | Sweep LED | Vacuum LED |
| 36           | Vacuum Contactor Coil Open         | x              | x        | x       | x     | x        |            |              | x                |                 |              | x           | x         | x          |
| 37           | Chemical Pump Open                 | x              |          |         |       |          |            |              |                  | x               |              |             |           |            |
| 38           | Rear Brush Motor Open              | x              | x        | x       | x     |          |            | x            | x                |                 |              | x           | x         |            |
| 39           | Solution Pump Open                 | x              | x        | x       |       |          |            |              | x                |                 | x            | x           |           |            |
| 40           | Restore Solenoid Open              | x              | x        | x       |       |          |            |              |                  |                 |              | x           |           |            |
| 41           | Misting Solenoid Open              |                | x        |         |       |          |            |              | x                |                 |              |             |           |            |
| 60           | Front Brush motor Stuck Closed     |                |          |         |       |          |            |              |                  |                 |              |             |           |            |
| 61           | Vacuum Motor Stuck Closed          |                |          |         |       |          |            |              |                  |                 |              |             |           |            |
| 62           | Maintenance Solenoid Stuck Closed  |                |          |         | x     |          |            |              | x                |                 |              |             |           |            |
| 63           | Brush Contactor Coil Stuck Closed  |                |          |         |       |          |            |              |                  |                 |              |             |           |            |
| 64           | Vacuum Contactor Coil Stuck Closed |                |          |         |       |          |            |              |                  |                 |              |             |           |            |
| 65           | Restore Solenoid Stuck Closed      |                |          |         | x     |          |            |              | x                |                 |              |             |           |            |
| 66           | Misting Solenoid Stuck Closed      |                |          | x       |       |          |            |              |                  |                 |              |             |           |            |
| 67           | Rear Brush motor Stuck Closed      |                |          |         |       |          |            |              |                  |                 |              |             |           |            |

Figure E-33: Disabled Systems for each fault code (Note: Flash indicator at 1 hz rate)

## Removal and Installation

### Replace the Main Control Board

**⚠ Caution!** You must disconnect the batteries from the machine at the battery connector before accessing the control board.

Flip the operator's seat upward and prop it in place.

Remove the 4 screws from the Control Panel assembly.

Lift and tilt the Control Panel Assembly to access the board underneath.



**⚠ Caution!** To prevent damage to the control panel assembly due to static electricity (ESD), wear a properly grounded static control wrist strap before removing the new assembly from its protective static shielding bag. Wear the strap throughout the entire installation process until the four screws attaching the control panel to the machine have been fastened.

Note all wiring and hose connections. Disconnect the wiring and hose connections.

**⚠ Caution!** The ribbon cable(s) and membrane switch grounding film are fragile. Do not scratch or crease during disassembly or re-assembly or damage may occur.



**⚠ Caution!** DO NOT pull the clear tube off the control board or it WILL break the control board! Instead, use a razor knife and carefully cut the tube off the control board.

Remove the key switch from the control board panel assembly.

Remove the 5 screws from the board assembly. Save the screws and key switch. Discard the old board and replace it with the new one.

Install the new board assembly in the reverse order. Be extra careful when plugging in the connectors on the board.

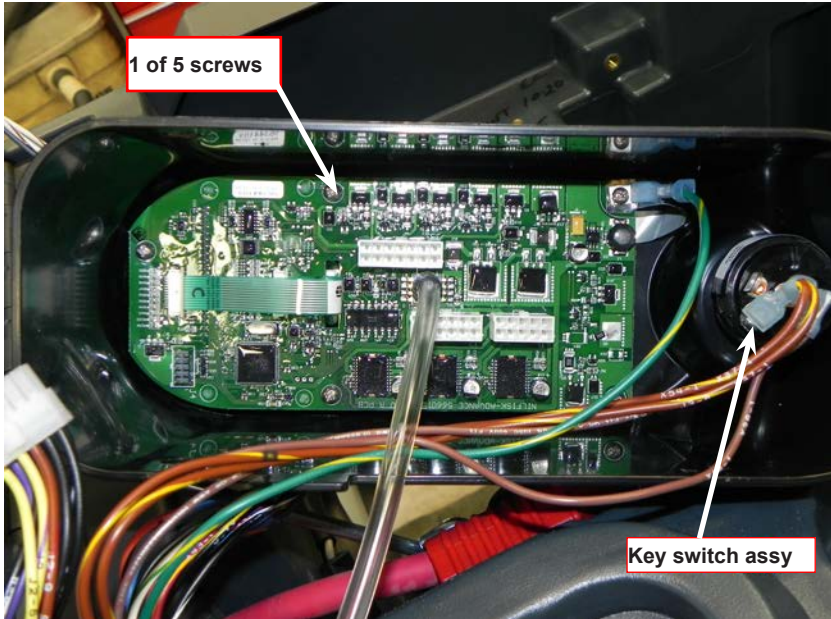

**⚠** *Note: After replacing the Main Controller, no special programming of operational values is required if the machine is equipped with WET BATTERIES. However, if the ES4000 machine is equipped with AGM or GEL batteries, it is MANDATORY to set the LOW VOLTAGE CUTOUT function in the Hidden Menus. By default, the initial setting is “Wet Battery 80%” but will need to be changed to “Main Free Battery 70%” if the machine has AGM or GEL batteries. Failure to do so may cause premature battery failure.*

## Specifications

### Shop Measurements – Main Controller

The following tables contain some “real world” shop voltage measurements to help you recognize what “normal” looks like. All voltage values were measured with the key switch on and the black (Negative) voltmeter lead connected to the main battery negative terminal unless otherwise specified.

| Pin ID | Wire Color | Description   | Measured Value                 | Comments   |
|--------|------------|---|--------------------------------|--|
| J1-1   | red/yel    | Chemical Pump “+” output  | 2v to 20v                      | Voltage should jump around when pump is operated                               |
| J1-2   | vio/org    | Solution Pump output  | 0.15v                          | When solution flows  |
| J1-3   | blu/gra    | Chemical Pump “-“ output  | 2v to 20v                      | Voltage should jump around when pump is operated                               |
| J1-4   | org/blk    | Brush Deck Actuator motor “+” output  | 23.9v up<br>0.26v down         | Measured when actuator was moving in both directions                           |
| J1-5   | blu        | Brush Deck Actuator motor “-“ output  | 23.7v up<br>0.15v down         | Measured when actuator was moving in both directions                           |
| J1-6   | vio/red    | Rear Brush Motor Current Sense input  | 0.02v                          | Brushes running without touching the floor                                     |
| J1-7   | blk/wht    | Restore solenoid output   | 0.18v                          | When energized   |
| J1-8   | blk/wht    | Battery “-“ input   | 0.05v                          | While operating in extract mode with vacuum motors on                          |
| J1-9   | blk/yel    | Shoe Actuator motor “-“ output  | 24.4v up<br>0.13v down         | Measured when actuator was moving in both directions                           |
| J1-10  | wht/grn    | Shoe Actuator motor “+” output  | 24.6v down<br>0.12v up         | Measured when actuator was moving in both directions                           |
| J2-1   | blk        | Battery “-“ input   | 0.02v                          | With vacuum motors running   |
| J2-2   |            | Not used  |                                |  |
| J2-3   |            | Not used  |                                |  |
| J2-4   | blk/wht    | Speed limit output<br><br>(Signal from main controller to speed controller) | 0.53v<br>1.29v<br>2.5v<br>4.5v | Restore mode<br>Maintenance mode<br>Prespray mode<br>Transport and Sweep modes |
| J2-5   | vio        | Speed limit pot low ref   | 0.38v                          |  |
| J2-6   | yel        | Speed limit pot high ref  | 4.58v                          |  |

| Pin ID | Wire Color | Description  | Measured Value | Comments   |
|--------|------------|--|----------------|--|
| J2-7   | blk        | Battery “-“ input  | 0.02v          | With vacuum motors running   |
| J2-8   | blk        | Battery “-“ input  | 0.02v          | With vacuum motors running   |
| J2-9   | brn/red    | Vacuum Motor Current Sense input   | 0.192v         | Vacuum on with open hose   |
|        |            |  | 0.150v         | Vacuum on with hose blocked  |
| J2-10  | yel/vio    | Front Brush Motor Current Sense input  | 0.028v         | Brush running with deck up   |
|        |            |  | 0.111v         | Brush running with deck all the way down   |
| J2-11  |            | Not used   |                |  |
| J2-12  |            | Not used   |                |  |
| J3-1   | brn/yel    | Battery “+“ lead   | 24.2v          | With vacuum motors running   |
| J3-2   | blk        | Battery “-“ input  | 0.02v          | With vacuum motors running   |
| J3-3   | blu/org    | Maintenance solenoid output  | 0,18v          | When energized   |
| J3-4   | gra/blk    | Seat Switch input  | 25.0v          | Switch closed  |
|        |            |  | 0.00v          | Switch open  |
| J3-5   | blu/blk    | Reverse Direction input from Speed Controller (input = GND when moving in reverse)                             | 1.55v          | Reverse  |
|        |            |  | 24.1v          | Neutral or Forward   |
| J3-6   | red/wht    | Fwd/Reverse input from Speed Controller (input = GND when moving in forward or reverse)                        | 0.24v          | Reverse or Neutral   |
|        |            |  | 24.1v          | Neutral  |
| J3-7   | org/blu    | Speed Controller Status input (input pulses between B+ and GND to indicate error status from Speed Controller) | 1.19v          | With no speed control faults   |
|        |            |  | 24v            | With speed control faults (The voltage jumps lower as the code signal is communicated) |
| J3-8   | brn/yel    | Battery “+“ lead   | 24.5v          | With vacuum motors running   |
| J3-9   | grn/blk    | Horn “-“ output  | 13.3v off      | Connects to battery negative to sound horn   |
|        |            |  | 0.01v on       |  |
| J3-10  | org/red    | Horn “+“ output  | 15.0v          | Constant power supply  |
| J3-11  | vio/blk    | Misting solenoid output  | 0.19v          | When energized   |
| J3-12  | gra/blk    | Vacuum Contactor output  | 0.26v          | When first energized (To pull in contactor)  |
|        |            |  | 4.8v           | After energized for a few seconds (To hold contactor)                                  |

| Pin ID | Wire Color | Description  | Measured Value | Comments  |
|--------|------------|--|----------------|---|
| J3-13  | wht/red    | Brush Motor<br>Contactor output                                      | 0.28v          | When first energized (To pull in contactor)           |
|        |            |  | 4.8v           | After energized for a few seconds (To hold contactor) |
| J3-14  | brn        | Key Switch input<br>(input = B+ voltage<br>when key is turned<br>on) | 24.1v          | With vacuum motors running                            |

# Electrical System

## Functional Description

The Electrical System is integrated throughout the machine functions. The main functional interface is the Operator's Interface Panel Assembly (See CONTROL SYSTEM, Control Panel). All operator's functions are initiated and controlled from this panel. The machine is Battery-powered and rechargeable. The drive system is variable speed controlled via the foot pedal and selection of various operational functions at the Control Panel.

An optional on-board Battery Charger is available for this machine. This manual shows the ES4000 with the Optional Battery Charger installed.

## Components Locations

- Batteries and connections
- Fuses, E-Stop button
- Battery charger
- Main operator's interface panel (see CONTROL SYSTEM)
- Speed controller (see WHEEL SYSTEM, TRACTION)

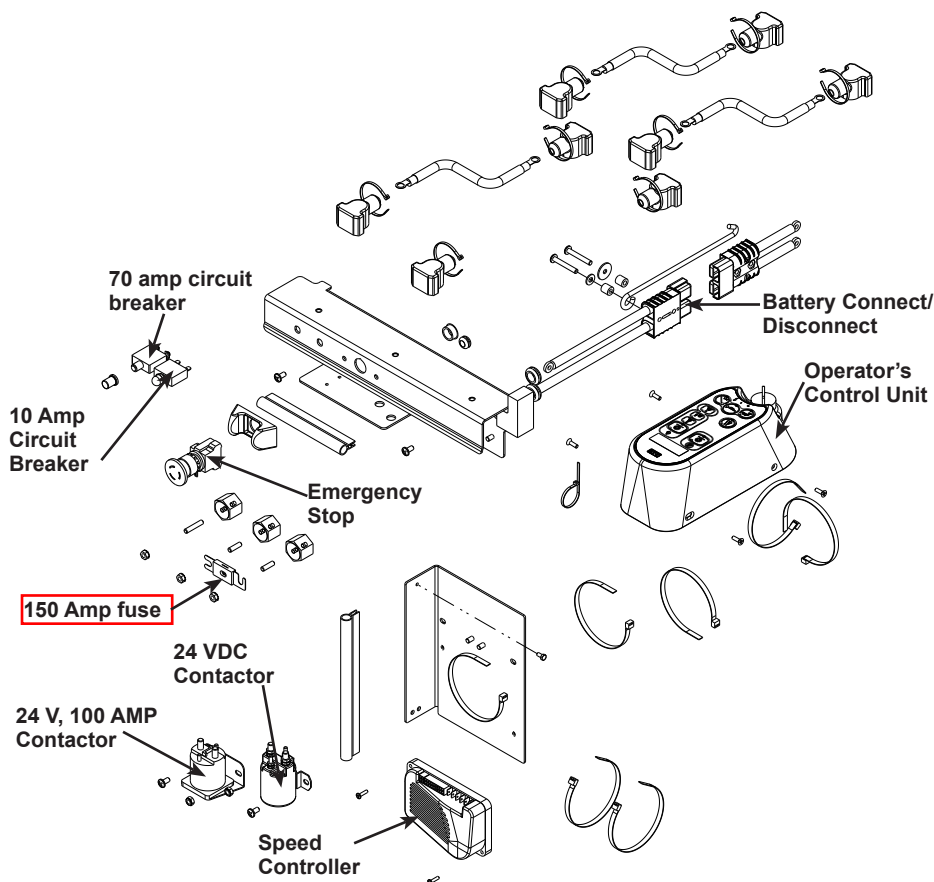

Batteries in battery tray with  
Recovery Tank removed and  
Operator's Seat up.



Battery connector (shown  
disconnected)



Fuses and E-stop locations



On-board Battery Charger



Operator's main interface panel (CONTROL PANEL)



Speed Controller



Main Electrical Panel

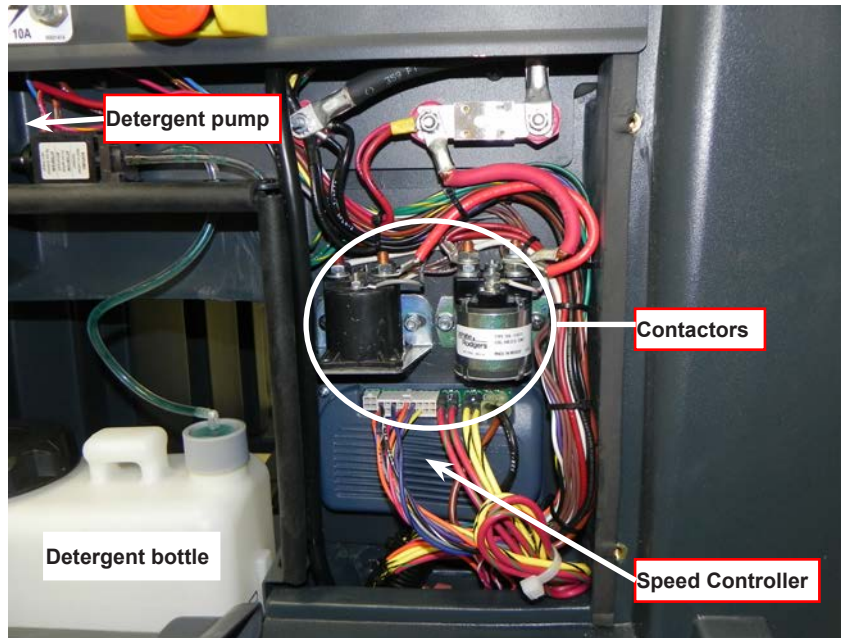

Electrical components in electrical panel

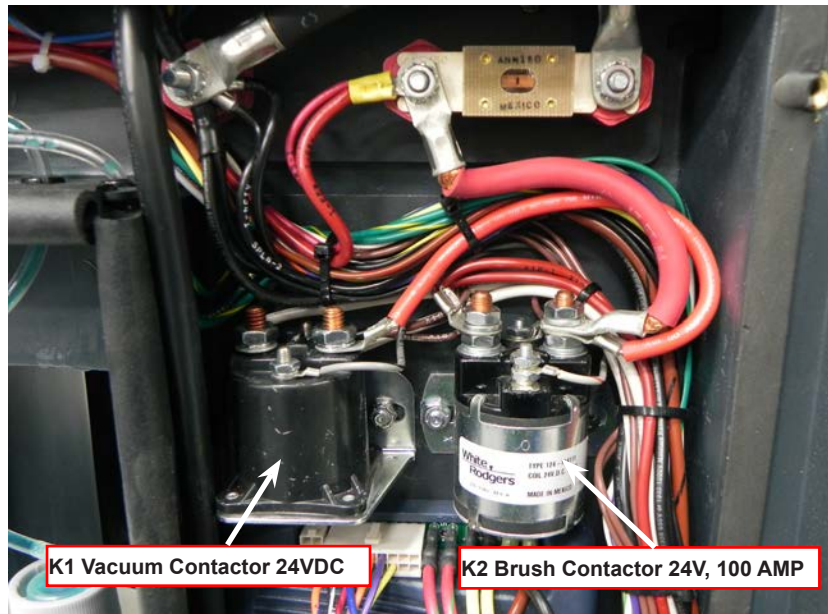

## Battery Specifications

Advance recommended battery pack capacity is a 310 or 420 AH @ 20 Hour Rate deep cycle battery system (four 6V-batteries). Note: The battery pack must fit the battery compartment size listed in Specifications.

## Battery Charger (on-board and portable)

- Use a 24V DC output charger matching the DC battery pack voltage and the input AC line voltage supply being used.
- Always when selecting a battery charger follow the recommendation of the battery supplier to match the proper charger DC output amperage to the amp/hour rating batteries being installed. This will prevent the battery pack from being over or under charged.
  - The recommended 310 AH battery should be matched to a 24V, 25 Amp charger. The recommended 420 AH battery should be matched to a 24V, 36 Amp charger.

## Removal and Installation



**On-Board Battery Charger and power cord**

## Install Batteries

 **WARNING!** Use extreme caution when working with batteries. Sulfuric acid in batteries can cause severe injury if allowed to contact the skin or eyes. Explosive hydrogen gas is vented from inside the batteries through openings in the battery caps. This gas can be ignited by any electrical arc, spark or flame.

### When Servicing Batteries:

- Remove all jewelry.
- Do not smoke.
- Wear chemical goggles, rubber gloves and a protective apron.
- Work in a well-ventilated area.
- Do not allow tools to touch more than one battery terminal at a time.

**CAUTION!** Electrical components in this machine can be severely damaged if the batteries are not installed and connected properly.



Turn the Master Key Switch OFF and remove the key from the Operator's Control Panel.

To access the battery compartment tip the operator's seat forward and set the prop rod. Remove the battery cables from inside the battery compartment. (Figure E-1).

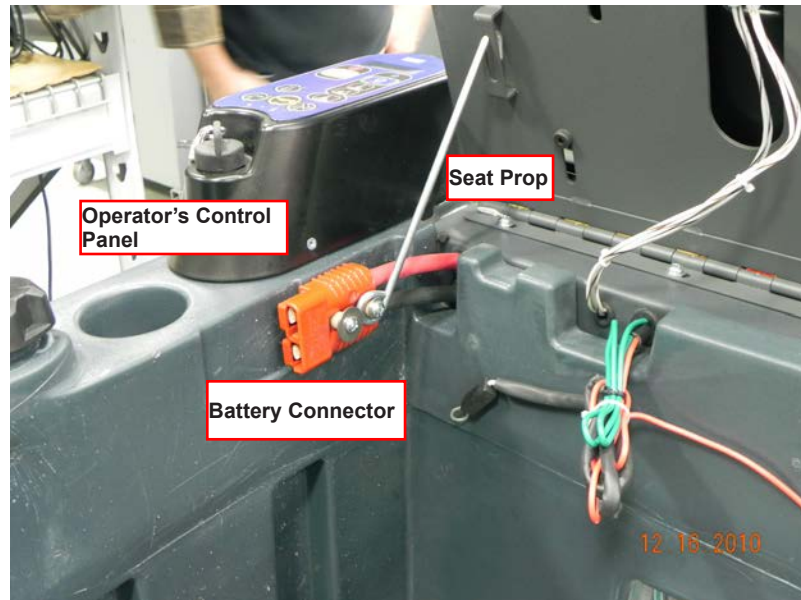

**Figure E-1**

Remove the batteries from their shipping crate and carefully inspect them for cracks or other damage. If damage is evident, contact the carrier that delivered them or the battery manufacturer to file a damage claim.

Your machine comes from the factory with enough battery cables to install four (6 volt), 420 Amp hour batteries. Using two people and an appropriate lifting strap, carefully lift the batteries into the compartment tray exactly as shown on machine decal (Figure E-2).

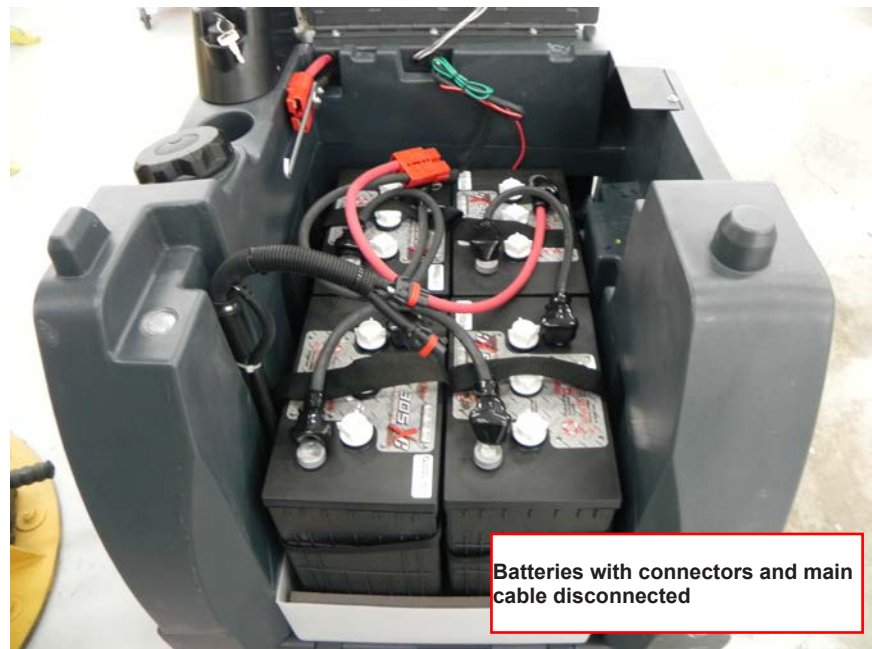
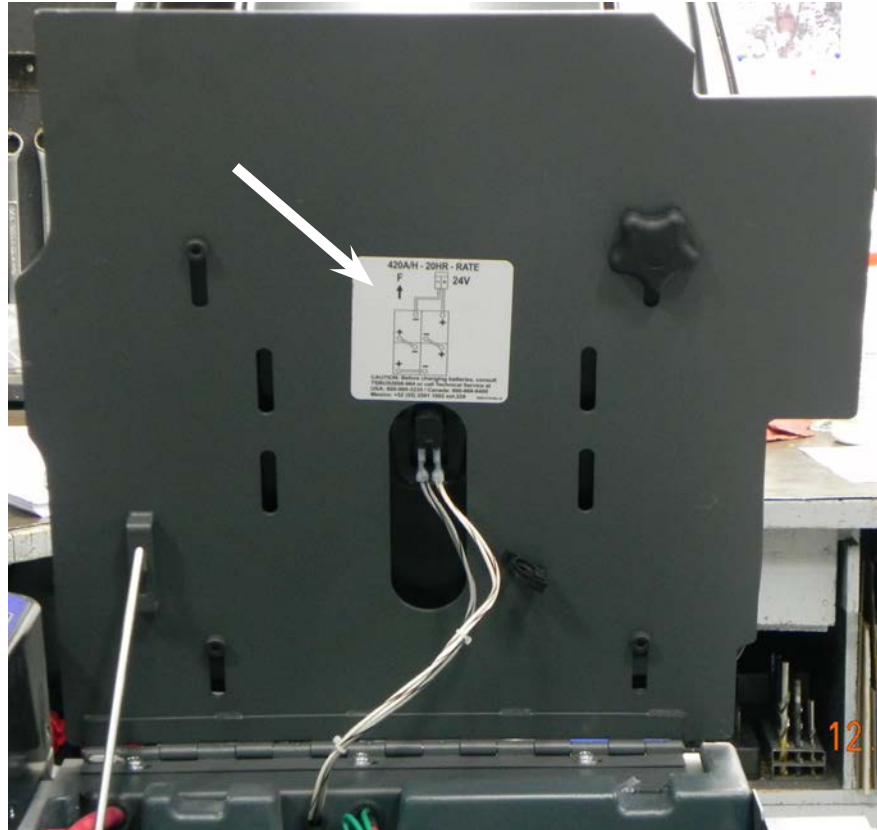

**Figure E-2**

The terminals on the battery cables are marked “+” for positive and “-“ for negative. Install the battery cables as shown, with the terminals marked “+” on the positive battery terminals and the terminals marked “-“ on the negative terminals. Position the cables so the battery caps can be easily removed for battery service.

Carefully tighten the nut in each battery terminal until the terminal will not turn on the battery post. Then tighten the nut half an additional turn. Do not over-tighten the terminals, or they will be very difficult to remove for future service.

Coat the terminals and posts with spray-on battery terminal coating (available at most auto parts stores).



Put one of the black rubber boots over each of the terminals and retain with supplied tie straps.

Connect the battery pack connector to the Machine Battery Connector and close the operator's seat platform.

## Battery Low Voltage Cutout Feature - Description

The ES4000 is equipped with a low voltage cutout feature to prevent over-discharging of the batteries. When a machine's battery pack voltage falls below specifically defined thresholds (voltage settings) the cleaning system is automatically shut down. The cutout level is adjustable. The standard lead acid battery (wet cell) setting is 1.72V per cell and alternate maintenance free battery (gel cell) setting is 1.81V per cell. The standard setting is factory selected and should be used unless the battery manufacturer specifies the higher cutout voltage. The Low Voltage Cutout is indicated by the Voltage Low indication shown on the display and everything is disabled except the Horn.

 *Special Service Note: On all machines (24V) a minimum recharge voltage of 25.08 volts (2.09 volts per cell) must be reached to allow the brush and solution system to (reset) function again following a low voltage cutout.*

## Battery Condition Indicator - Description

The Battery Condition Indicator will give an indication of the state of charge of the batteries. The battery condition indicator will retain the state-of-charge even if the key has been turned off. The state-of-charge indication is reset to full charge when the batteries have been recharged. It is also possible to choose between two different low voltage thresholds depending on whether maintenance free or standard batteries are being used.

The indicator is shown as an icon on the operator control panel's display. This icon is present 10 seconds after the Key Switch is turned ON. The icon is a battery with up to 5 vertical bars inside. The number of bars inside the icon represents the charge state of the battery as follows:

1. Battery full = 5 bars
2. Battery at 80% = 4 bars
3. Battery at 60% = 3 bars
4. Battery at 40% = 2 bars
5. Battery at 20% = 1 bar
6. Battery depleted = no bars

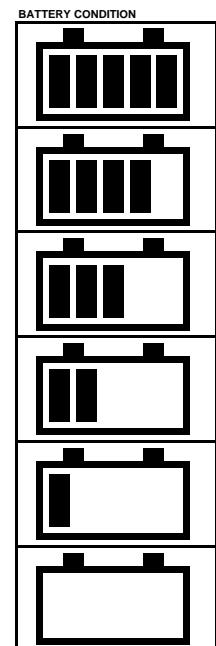

 *Important Note: See the Main Control Board Special Program Options manual section and follow the instructions for changing the low voltage cutout threshold.*

## Battery LOCK Value

The Battery LOCK Value is a term used by Nilfisk-Advance to reference the representation of the machine battery voltage after it is converted to a digital number and ran through the battery voltage monitoring algorithm. The LOCK value is used to determine the correct battery gauge level to be displayed on the LCD. The LOCK value is also used to trigger a LVI (Low Voltage Inhibit) warning. The LOCK value is nonvolatile and can only be reset as explained above for BATT\_RESET.

### Low voltage inhibit process

1. When Gel battery reaches LVI Lock value 17, turn off the brushes, pumps and solenoids and raise the brush deck. Still active are the shoe actuator, vacuum and horn.
2. When Gel battery reaches LVI Lock value 18, disable and turn off everything except horn.
3. When Wet battery reaches LVI Lock value 25, turn off the brushes, pumps and solenoids and raise the brush deck. Still active are the shoe actuator, vacuum and horn.
4. When Wet battery reaches LVI Lock value 26, disable and turn off everything except the horn

| LOCK | Battery Voltage Threshold | LCD Display        |                    |
|------|---------------------------|--------------------|--------------------|
|      |                           | Wet Battery        | Gel Battery        |
| 0    | 24.30                     | Batt Gauge = 5 Bar | Batt Gauge = 5 Bar |
| 1    | 24.15                     | Batt Gauge = 5 Bar | Batt Gauge = 5 Bar |
| 2    | 24.0                      | Batt Gauge = 5 Bar | Batt Gauge = 5 Bar |
| 3    | 23.85                     | Batt Gauge = 4 Bar | Batt Gauge = 4 Bar |
| 4    | 23.7                      | Batt Gauge = 4 Bar | Batt Gauge = 4 Bar |
| 5    | 23.55                     | Batt Gauge = 3 Bar | Batt Gauge = 3 Bar |
| 6    | 23.4                      | Batt Gauge = 3 Bar | Batt Gauge = 3 Bar |
| 7    | 23.25                     | Batt Gauge = 3 Bar | Batt Gauge = 2 Bar |
| 8    | 23.1                      | Batt Gauge = 2 Bar | Batt Gauge = 2 Bar |
| 9    | 22.95                     | Batt Gauge = 2 Bar | Batt Gauge = 2 Bar |
| 10   | 22.8                      | Batt Gauge = 2 Bar | Batt Gauge = 1 Bar |
| 11   | 22.65                     | Batt Gauge = 2 Bar | Batt Gauge = 1 Bar |
| 12   | 22.5                      | Batt Gauge = 2 Bar | Batt Gauge = 1 Bar |
| 13   | 22.35                     | Batt Gauge = 1 Bar | Batt Gauge = 0 Bar |
| 14   | 22.2                      | Batt Gauge = 1 Bar | Batt Gauge = 0 Bar |

| LOCK | Battery Voltage Threshold | LCD Display           |                       |
|------|---------------------------|-----------------------|-----------------------|
|      |                           | Wet Battery           | Gel Battery           |
| 15   | 22.05                     | Batt Gauge = 1<br>Bar | Batt Gauge = 0<br>Bar |
| 16   | 21.9                      | Batt Gauge = 1<br>Bar | Batt Gauge = 0<br>Bar |
| 17   | 21.75                     | Batt Gauge = 1<br>Bar | LVI                   |
| 18   | 21.6                      | Batt Gauge = 1<br>Bar | LVI                   |
| 19   | 21.45                     | Batt Gauge = 0<br>Bar | LVI                   |
| 20   | 21.3                      | Batt Gauge = 0<br>Bar | LVI                   |
| 21   | 21.15                     | Batt Gauge = 0<br>Bar | LVI                   |
| 22   | 21.0                      | Batt Gauge = 0<br>Bar | LVI                   |
| 23   | 20.85                     | Batt Gauge = 0<br>Bar | LVI                   |
| 24   | 20.7                      | Batt Gauge = 0<br>Bar | LVI                   |
| 25   | 20.55                     | LVI                   | LVI                   |
| 26   | 20.4                      | LVI                   | LVI                   |
| 27   | 20.25                     | LVI                   | LVI                   |
| 28   | 20.1                      | LVI                   | LVI                   |
| 29   | 19.95                     | LVI                   | LVI                   |
| 30   | 19.8                      | LVI                   | LVI                   |

**Battery Voltage Threshold and LCD Display for given LOCK values**

## Maintenance and Adjustments

### Battery Maintenance

Proper maintenance of electric vehicle batteries can greatly extend their life. Well-maintained batteries may last up to 3 years, but failure after 1 year is common if maintenance has been poor. There are 3 simple rules for good battery maintenance:

- **Maintain Proper Electrolyte Level (Weekly)** - Use distilled water in batteries whenever possible. If batteries are discharged, add just enough water to cover the plates in each cell. If batteries are fully charged, fill each cell to the bottom of the filler tube. Do not over-fill the batteries! Do not add acid to batteries!
- **Keep the Batteries Charged (Weekly)** - Batteries should be charged each time that a machine is used for more than 1 hour. Machine operators should open the battery compartment cover for charging, to avoid a concentrated build-up of hydrogen gas. Operators should follow the instructions provided with their specific battery charger, to determine how long the batteries should be charged. Even when a machine is stored, the batteries should be charged once a month to prevent the batteries from “sulfating”. Almost all battery caps are vented, so there’s no need to loosen or remove them for charging.
- **Keep the Batteries Clean (Monthly)** - Use a damp cloth to wipe dirt from the top of the batteries. Battery terminals must be clean and tight. If the tops of the batteries are wet after charging, the batteries have probably been over-filled or over-charged. Note: If there is acid on the batteries, wash the tops of the batteries with a solution of baking soda and water (2) tablespoons of baking soda to 1 quart of water.

### Charging the Batteries

Charge the machine’s battery pack each time the machine is used, or when the Battery Condition Indicator show no vertical bars in the battery icon.



*Note: The machine also uses a special low voltage cutout that inhibits the cleaning system see in this manual section the Description of the Battery Low Voltage Cutout Feature.*

#### To Charge the Batteries.

1. Disconnect the Battery Connector.
2. Lift the seat and prop it open with the prop rod to provide proper ventilation.
3. Push the connector from the charger into the Battery Connector.
4. Follow the instructions on the battery charger.
5. Check the fluid level in all battery cells after charging the batteries. Add distilled water, if necessary, to bring the fluid level up to the bottom of the filler tubes.



**WARNING! Do not fill the batteries before charging. Only charge batteries in a well-ventilated area. Do not smoke while servicing the batteries.**

## Battery Testing

A battery problem is usually recognized by the machine operator as a decrease in the machine's running time. This condition is usually caused by one or more "dead cells" in the battery system (one or more cells that is producing less voltage than the other cells).



*Note: Always charge batteries before testing. There are 2 ways to find a dead cell:*

- Use a hydrometer to check the specific gravity (or "state of charge") of the fluid in each cell. A dead cell is one that reads 50 points (or more) lower than the other cells.
- Use a volt meter to check the voltage of each battery with the cleaning and drive motors running. The battery with the dead cell will read 1 or 2 volts lower than the other batteries in the system.
- If the batteries in the machine are more than 1 year old, it's usually best to replace the whole set, rather than replacing just one battery. As batteries age, their maintenance requirements change. As they age they usually require longer charging times and a higher finish rate. A newer battery mixed in with old batteries will end up being overcharged and cause it to fail prematurely.

The table below shows the approximate "percent charged" of an electric vehicle battery at various specific gravity values, corrected to 80°F (26.7°C).

| APPROXIMATE STATE OF CHARGE |                           |
|-----------------------------|---------------------------|
| Charged                     | 1.265 Initial Full Charge |
| 100%                        | 1.265                     |
| 75%                         | 1.225                     |
| 50%                         | 1.190                     |
| 25%                         | 1.155                     |
| Discharged                  | 1.120                     |

### Machine and Chassis Wiring

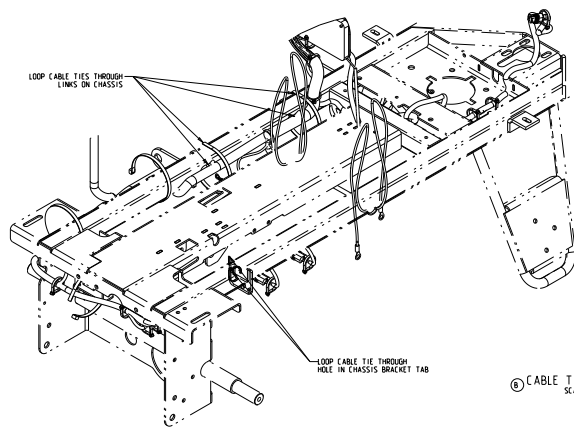

⑥ CABLE TIE LOCATIONS  
SCALE 0.380

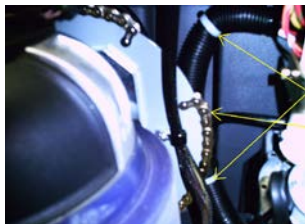
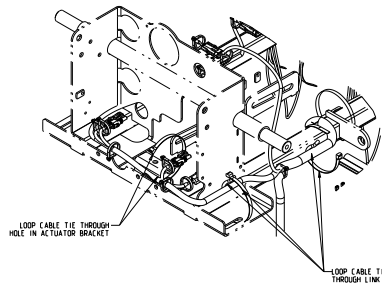

### Machine and Chassis Wiring

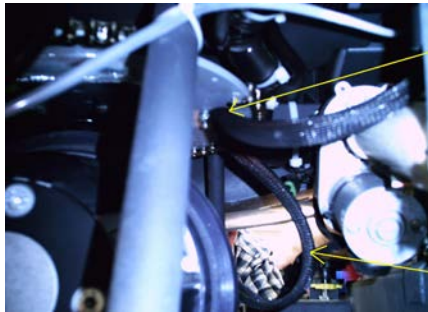

SECURE TRACTION HARNESS TO P-CLIP ON STEERING PLATE

ALLOW APPROX. 12" LOOP FOR WHEEL MOVEMENT

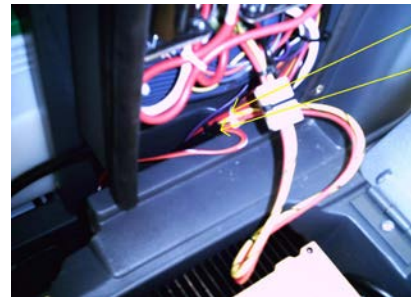

TIE WRAP TRACTION HARNESS TO MAIN HARNESS

END OF BLACK FLEX CONDUIT TO BE NO MORE THAN 1" BELOW TOP SURFACE OF TANK



GROUNDING WIRES SECURED TO FRAME AT THIS POINT

HARNESS BRANCH TO RUN UNDER PLATE HOLDING BATTERY CHARGER

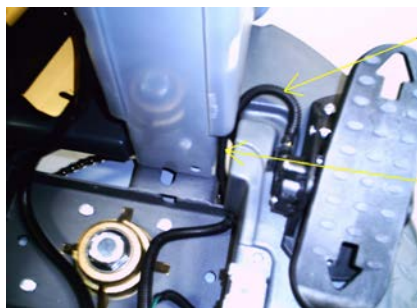

HARNESS TO LAY IN CHANNEL

HARNESS TO RUN UP ALONG RIGHT SIDE OF STEERING PILLER

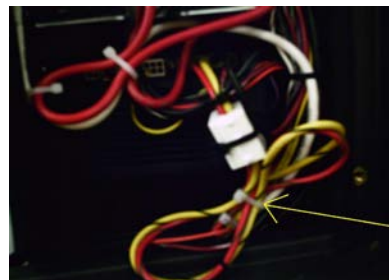

DOUBLE BACK THE SLACK IN THE TRACTION HARNESS AND TIE WRAP AGAIN TO MAIN HARNESS

## Specifications

### INPUT/OUTPUT TABLES

| Designation | Pin ID | Wire ID/ Color | Description  | Signal Characteristic                                  | Nominal Value | Reference To: | Range            | Comments  |
|-------------|--------|----------------|--|--|---------------|---------------|------------------|---|
| output      | J1-1   | red/<br>yel    | Chemical Pump “+” output   | pulsed voltage   | +24V          | B-            | 20.5 to 25.5 V   | This signal alternates between 0V and 24V when chemical pump is active  |
| output      | J1-2   | vio/<br>org    | Solution Pump output   | PWM voltage (sweep mode);<br>DC voltage (extract mode) | 0V            | B-            | 0 to 0.100 V     | voltage on this pin cycles between 0 and 24V; pump is energized when this voltage = 0V; PWM period = 6 seconds; duty cycle = 17% for sweep mode & 100% for extract mode |
| output      | J1-3   | blu/<br>gra    | Chemical Pump “-” output   | pulsed voltage   | +24V          | B-            | 20.5 to 25.5 V   | This signal alternates between 0V and 24V when chemical pump is active  |
| output      | J1-4   | org/<br>blk    | Brush Deck Actuator motor “+” output   | DC voltage   | +24V          | B-            | 20.5 to 25.5 V   | 24V when lowering deck; 0 volts when raising deck   |
| output      | J1-5   | blu            | Brush Deck Actuator motor “-” output   | DC voltage   | +24V          | B-            | 20.5 to 25.5 V   | 24V when raising deck; 0 volts when lowering deck   |
| input       | J1-6   | vio/<br>red    | Rear Brush Motor Current Sense input (voltage on this wire wrt GND represents the motor current) | Analog voltage   | 0.036 V       | B-            | 0.011 to 0.075 V | voltage is present only if brush motor is ON; voltage range corresponds to motor load range = 3 to 21A  |
| output      | J1-7   | blk/<br>wht    | Restore solenoid output  | DC voltage   | 0V            | B-            | 0 to 0.100 V     | Voltage = nominal 0 V when solenoid is energized and 24 V otherwise   |
| ground      | J1-8   | blk/<br>wht    | Battery “-” input  | DC voltage   | -24V          | B+            | -20.5 to -25.5 V | “-” terminal of battery   |

| Designation   | Pin ID | Wire ID/ Color | Description  | Signal Characteristic | Nominal Value | Reference To: | Range            | Comments  |
|---------------|--------|----------------|--|-----------------------|---------------|---------------|------------------|---|
| output        | J1-9   | blk/<br>yel    | Shoe Actuator motor “-” output   | DC voltage            | +24V          | B-            | 20.5 to 25.5 V   | 24V when raising deck; 0 volts when lowering deck   |
| output        | J1-10  | wht/<br>grn    | Shoe Actuator motor “+” output   | DC voltage            | +24V          | B-            | 20.5 to 25.5 V   | 24V when lowering deck; 0 volts when raising deck   |
| ground        | J2-1   | blk            | Battery “-“ input  | DC voltage            | -24V          | B+            | -20.5 to -25.5 V | “-” terminal of battery   |
| ground        | J2-2   |                |  |                       |               |               |                  |   |
| no connection | J2-3   |                |  |                       |               |               |                  |   |
| output        | J2-4   | blk/<br>wht    | speed limit pot wiper output   | Analog voltage        | +5V           | B-            | 0.0 to 5.0 V     | 0V corresponds to machine stopped, 5V corresponds to max allowed speed                          |
| input         | J2-5   | vio            | speed limit pot low ref  | DC voltage            | 0V            | B-            | 0 to 0.100 V     | 0V supply provided by the speed controller for the speed limit pots                             |
| input         | J2-6   | yel            | speed limit pot high ref   | DC voltage            | +5V           | B-            | 4.90 to 5.10 V   | power supply voltage provided by the speed controller for the speed limit pots                  |
| ground        | J2-7   | blk            | Battery “-“ input  | DC voltage            | -24V          | B+            | -20.5 to -25.5 V | “-” terminal of battery   |
| ground        | J2-8   | blk            | Battery “-“ input  | DC voltage            | -24V          | B+            | -20.5 to -25.5 V | “-” terminal of battery   |
| input         | J2-9   | brn/<br>red    | Vacuum Motor Current Sense input (voltage on this wire wrt GND represents the motor current) | Analog voltage        | 0.130 V       | B-            | 0.103 to 0.154 V | voltage is present only if vacuum is ON; voltage range corresponds to current range = 30 to 45A |

| Designation   | Pin ID | Wire ID/ Color | Description   | Signal Characteristic | Nominal Value | Reference To: | Range            | Comments  |
|---------------|--------|----------------|---|-----------------------|---------------|---------------|------------------|---|
| input         | J2-10  | yel/<br>vio    | Front Brush Motor Current Sense input (voltage on this wire wrt GND represents the motor current) | Analog voltage        | 0.050         | B-            | 0.011 to 0.075 V | voltage is present only if brush motor is ON; voltage range corresponds to motor load range = 3 to 21A              |
| no connection | J2-11  |                |   |                       |               |               |                  |   |
| no connection | J2-12  |                |   |                       |               |               |                  |   |
| Designation   | Pin ID | Wire ID/ Color | Description   | Signal Characteristic | Nominal Value | Reference To: | Range            | Comments  |
| power         | J3-1   | brn/<br>yel    | Battery "+" lead  | DC voltage            | + 24 V        | B-            | 20.5-25.5 V      | "+" terminal of battery   |
| ground        | J3-2   | blk            | Battery "-" input   | DC voltage            | -24V          | B+            | -20.5 to -25.5 V | "-" terminal of battery   |
| output        | J3-3   | blu/<br>org    | Maintenance solenoid output   | DC voltage            | 0V            | B-            | 0 to 0.100 V     | Voltage = nominal 0 V when solenoid is energized and 24 V otherwise   |
| input         | J3-4   | gra/<br>blk    | Seat Switch input   | DC voltage            | +24V          | B-            | 20.5 to 25.5 V   | This signal is 24V when the seat switch is closed (someone is sitting on the seat) and 0V when seat switch is open. |
| input         | J3-5   | blu/<br>blk    | Reverse Direction input from Speed Controller (input = GND when moving in reverse)                | DC voltage            | 0V            | B-            | 0 to 0.100 V     | Voltage = nominal 0V when drive motor is operating in reverse; voltage = nominal 24V all other times                |

| Designation | Pin ID | Wire ID/ Color | Description  | Signal Characteristic | Nominal Value | Reference To: | Range          | Comments  |
|-------------|--------|----------------|--|-----------------------|---------------|---------------|----------------|---|
| input       | J3-6   | red/<br>wht    | Fwd/Reverse input from Speed Controller (input = GND when moving in forward or reverse)                        | DC voltage            | 0V            | B-            | 0 to 0.100 V   | Voltage = nominal 0V when drive motor is moving; voltage = nominal 24V when in neutral  |
| input       | J3-7   | org/<br>blu    | Speed Controller Status input (input pulses between B+ and GND to indicate error status from Speed Controller) | DC voltage            | 0V            | B-            | 0 to 0.200 V   | voltage = nominal 0V when there is no speed controller fault; voltage pulses between 0V and 24V when there is a fault with the speed controller. PULSED SIGNAL EQUAL TO THE FAULT CODE FLASHED BY THE SPEED CONTROL BUILT-IN STATUS LED |
| power       | J3-8   | brn/<br>yel    | Battery "+" lead   | DC voltage            | +24V          | B-            | 20.5 to 25.5 V | "+" terminal of battery   |
| output      | J3-9   | grn/<br>blk    | horn "-" output  | PWM voltage           | 0V            | B-            | 0 to 0.200 V   | when horn button is pressed, this signal = 0V. When moving in reverse or when switching machine modes this signal pulses between 0 and 24V using a 50% duty cycle with the on time further modulated at 1 KHz.                          |
| output      | J3-10  | org/<br>red    | horn "+" output  | DC voltage            | +15V          | B-            | 14.7 to 15.3 V | constant 15V as supplied by PCB   |
| output      | J3-11  | vio/<br>blk    | Misting solenoid output  | DC voltage            | 0V            | B-            | 0 to 0.100 V   | Voltage = nominal 0 V when solenoid is energized and 24 V otherwise   |

| Designation | Pin ID | Wire ID/ Color | Description                                       | Signal Characteristic | Nominal Value | Reference To: | Range          | Comments  |
|-------------|--------|----------------|---|-----------------------|---------------|---------------|----------------|---|
| output      | J3-12  | gra/ blk       | Vacuum Contactor output                           | PWM voltage           | 0V            | B-            | 0 to 0.100 V   | voltage on this pin cycles between 0 and 24V; contactor is energized when this voltage = 0V; PWM frequency = 5KHz; duty cycle = 100% for startup and 80% steady state when vacuum is ON     |
| output      | J3-13  | wht/ red       | Brush Motor Contactor output                      | PWM voltage           | 0V            | B-            | 0 to 0.100 V   | voltage on this pin cycles between 0 and 24V; contactor is energized when this voltage = 0V PWM frequency = 5KHz; duty cycle = 100% for startup and 80% steady state when brush motor is ON |
| input       | J3-14  | brn            | Key Switch input (input = B+ voltage - key is on) | DC voltage            | +24V          | B-            | 20.5 to 25.5 V | voltage is = battery voltage when the key switch is ON  |

### Shop Measurements – Main Controller

The following tables contain some “real world” shop voltage measurements to help you recognize what “normal” looks like. All voltage values were measured with the key switch on and the black (Negative) voltmeter lead connected to the main battery negative terminal unless otherwise specified.

| Pin ID | Wire Color | Description   | Measured Value                 | Comments   |
|--------|------------|---|--------------------------------|--|
| J1-1   | red/yel    | Chemical Pump “+” output  | 2v to 20v                      | Voltage should jump around when pump is operated                           |
| J1-2   | vio/org    | Solution Pump output  | 0.15v                          | When solution flows  |
| J1-3   | blu/gra    | Chemical Pump “-“ output  | 2v to 20v                      | Voltage should jump around when pump is operated                           |
| J1-4   | org/blk    | Brush Deck Actuator motor “+” output  | 23.9v up<br>0.26v down         | Measured when actuator was moving in both directions                       |
| J1-5   | blu        | Brush Deck Actuator motor “-“ output  | 23.7v up<br>0.15v down         | Measured when actuator was moving in both directions                       |
| J1-6   | vio/red    | Rear Brush Motor Current Sense input  | 0.02v                          | Brushes running without touching the floor                                 |
| J1-7   | blk/wht    | Restore solenoid output   | 0.18v                          | When energized   |
| J1-8   | blk/wht    | Battery “-“ input   | 0.05v                          | While operating in extract mode with vacuum motors on                      |
| J1-9   | blk/yel    | Shoe Actuator motor “-“ output  | 24.4v up<br>0.13v down         | Measured when actuator was moving in both directions                       |
| J1-10  | wht/grn    | Shoe Actuator motor “+” output  | 24.6v down<br>0.12v up         | Measured when actuator was moving in both directions                       |
| J2-1   | blk        | Battery “-“ input   | 0.02v                          | With vacuum motors running   |
| J2-2   |            | Not used  |                                |  |
| J2-3   |            | Not used  |                                |  |
| J2-4   | blk/wht    | Speed limit output<br><br>(Signal from main controller to speed controller) | 0.53v<br>1.29v<br>2.5v<br>4.5v | Restore mode<br>Interim mode<br>Pretreat mode<br>Transport and Sweep modes |
| J2-5   | vio        | Speed limit pot low ref   | 0.38v                          |  |
| J2-6   | yel        | Speed limit pot high ref  | 4.58v                          |  |
| J2-7   | blk        | Battery “-“ input   | 0.02v                          | With vacuum motors running   |
| J2-8   | blk        | Battery “-“ input   | 0.02v                          | With vacuum motors running   |

| Pin ID | Wire Color | Description  | Measured Value | Comments   |
|--------|------------|--|----------------|--|
| J2-9   | brn/red    | Vacuum Motor Current Sense input   | 0.192v         | Vacuum on with open hose   |
|        |            |  | 0.150v         | Vacuum on with hose blocked  |
| J2-10  | yel/vio    | Front Brush Motor Current Sense input  | 0.028v         | Brush running with deck up   |
|        |            |  | 0.111v         | Brush running with deck all the way down   |
| J2-11  |            | Not used   |                |  |
| J2-12  |            | Not used   |                |  |
| J3-1   | brn/yel    | Battery “+” lead   | 24.2v          | With vacuum motors running   |
| J3-2   | blk        | Battery “-” input  | 0.02v          | With vacuum motors running   |
| J3-3   | blu/org    | Maintenance solenoid output  | 0,18v          | When energized   |
| J3-4   | gra/blk    | Seat Switch input  | 25.0v          | Switch closed  |
|        |            |  | 0.00v          | Switch open  |
| J3-5   | blu/blk    | Reverse Direction input from Speed Controller (input = GND when moving in reverse)                             | 1.55v          | Reverse  |
|        |            |  | 24.1v          | Neutral or Forward   |
| J3-6   | red/wht    | Fwd/Reverse input from Speed Controller (input = GND when moving in forward or reverse)                        | 0.24v          | Reverse or Neutral   |
|        |            |  | 24.1v          | Neutral  |
| J3-7   | org/blu    | Speed Controller Status input (input pulses between B+ and GND to indicate error status from Speed Controller) | 1.19v          | With no speed control faults   |
|        |            |  | 24v            | With speed control faults (The voltage jumps lower as the code signal is communicated) |
| J3-8   | brn/yel    | Battery “+” lead   | 24.5v          | With vacuum motors running   |
| J3-9   | grn/blk    | Horn “-” output  | 13.3v off      | Connects to battery negative to sound horn   |
|        |            |  | 0.01v on       |  |
| J3-10  | org/red    | Horn “+” output  | 15.0v          | Constant power supply  |
| J3-11  | vio/blk    | Misting solenoid output  | 0.19v          | When energized   |
| J3-12  | gra/blk    | Vacuum Contactor output  | 0.26v          | When first energized (To pull in contactor)  |
|        |            |  | 4.8v           | After energized for a few seconds (To hold contactor)                                  |

| Pin ID | Wire Color | Description   | Measured Value | Comments   |
|--------|------------|---|----------------|--|
| J3-13  | wht/red    | Brush Motor Contactor output                                | 0.28v<br>4.8v  | When first energized (To pull in contactor)<br>After energized for a few seconds (To hold contactor) |
| J3-14  | brn        | Key Switch input (input = B+ voltage when key is turned on) | 24.1v          | With vacuum motors running   |

# Wiring (Ladder) Diagram 56344090 Rev. C (1 of 2)

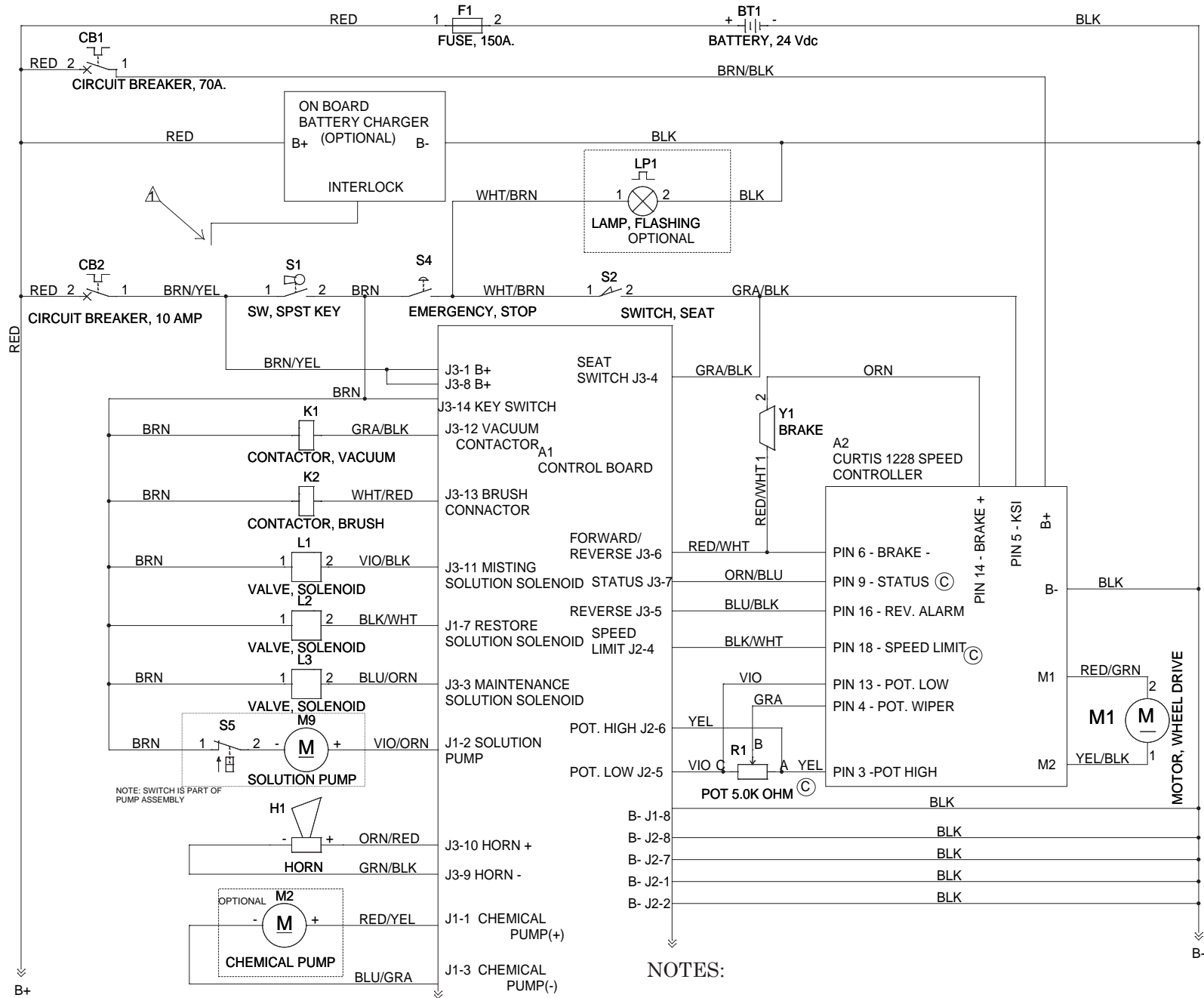

Wiring (Ladder) Diagram 56344090 Rev. C (2 of 2)

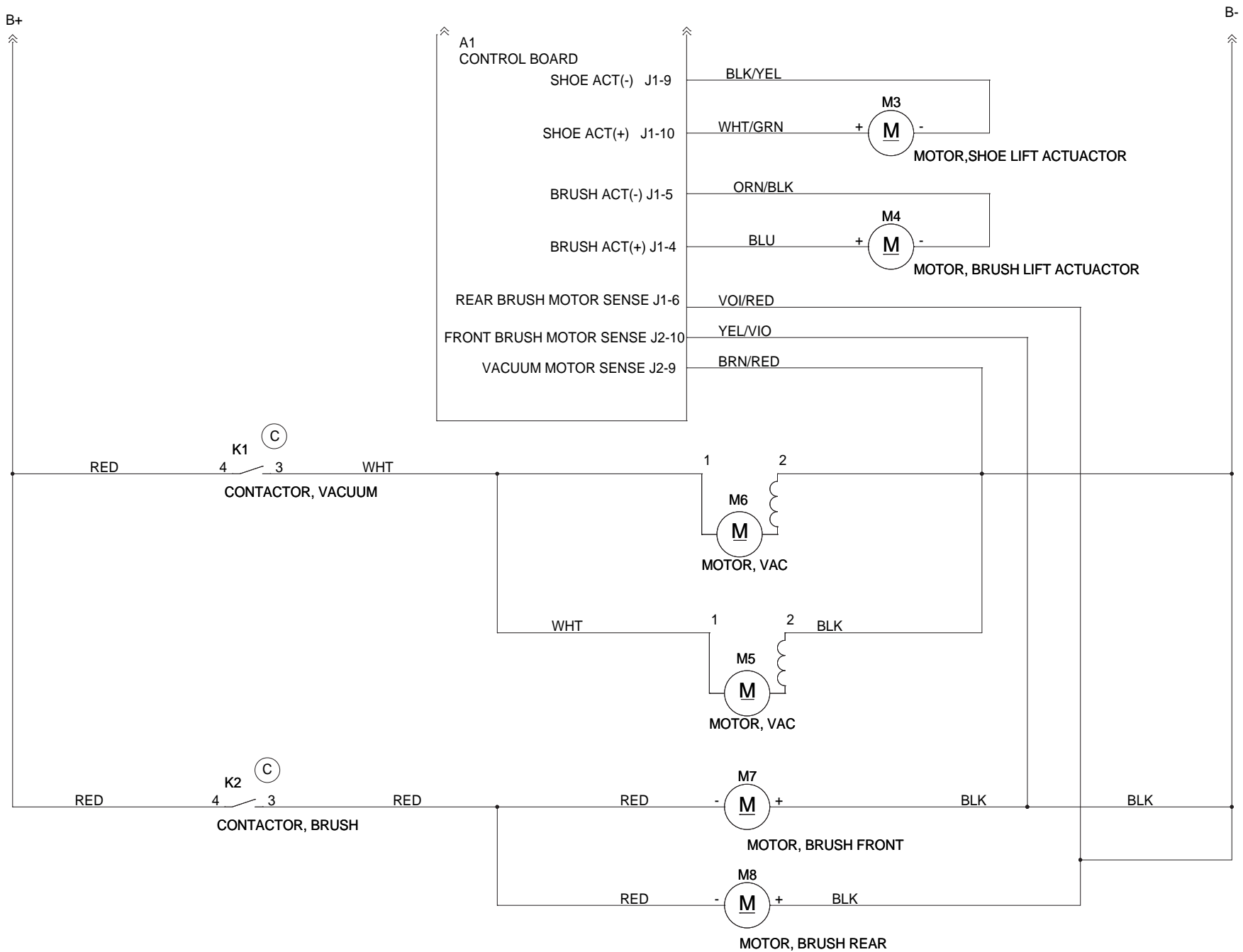

# Wiring Harness Diagram 56344091 Rev. C (1 of 2)

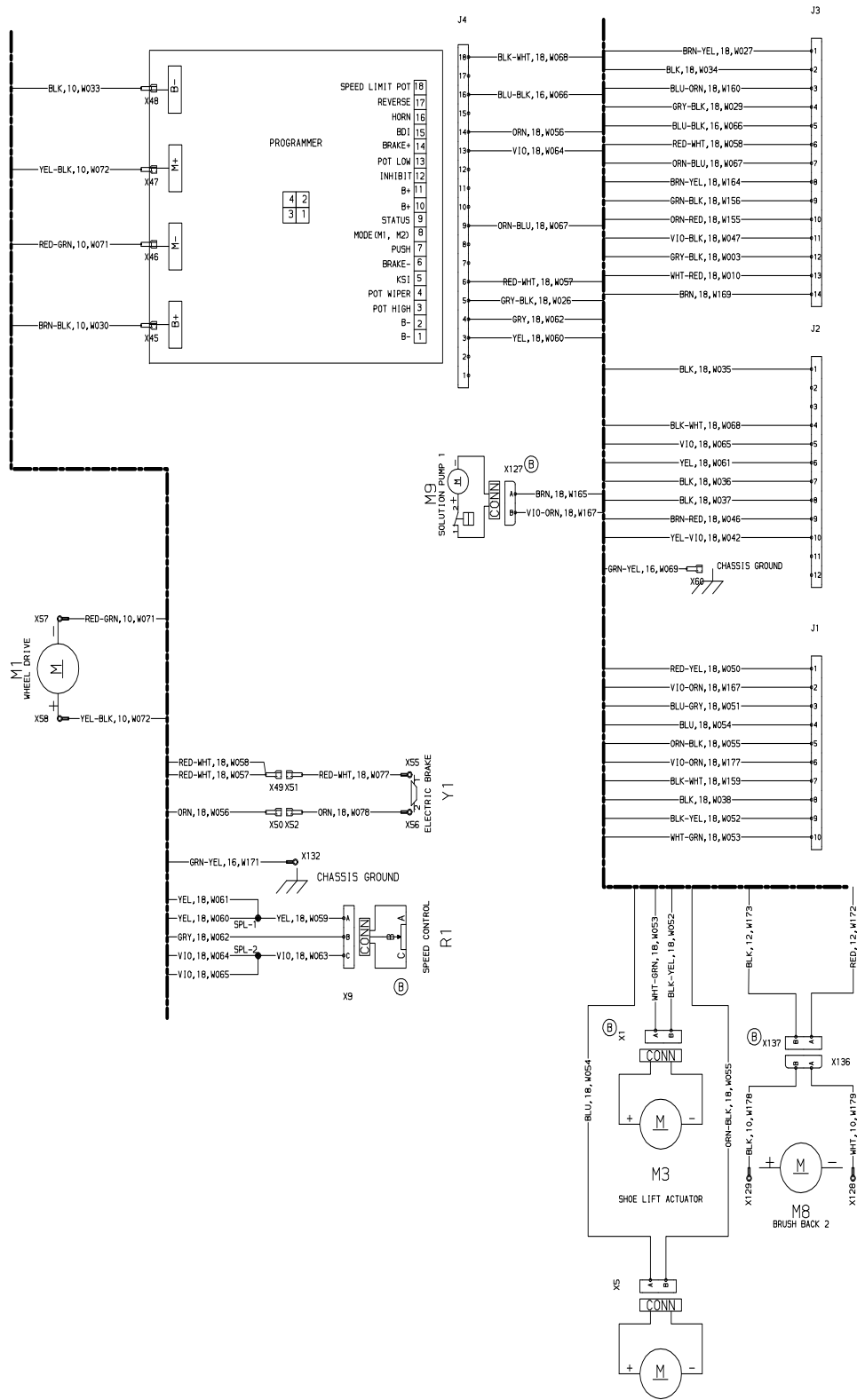

### Wiring Harness Diagram 56344091 Rev. C (2 of 2)

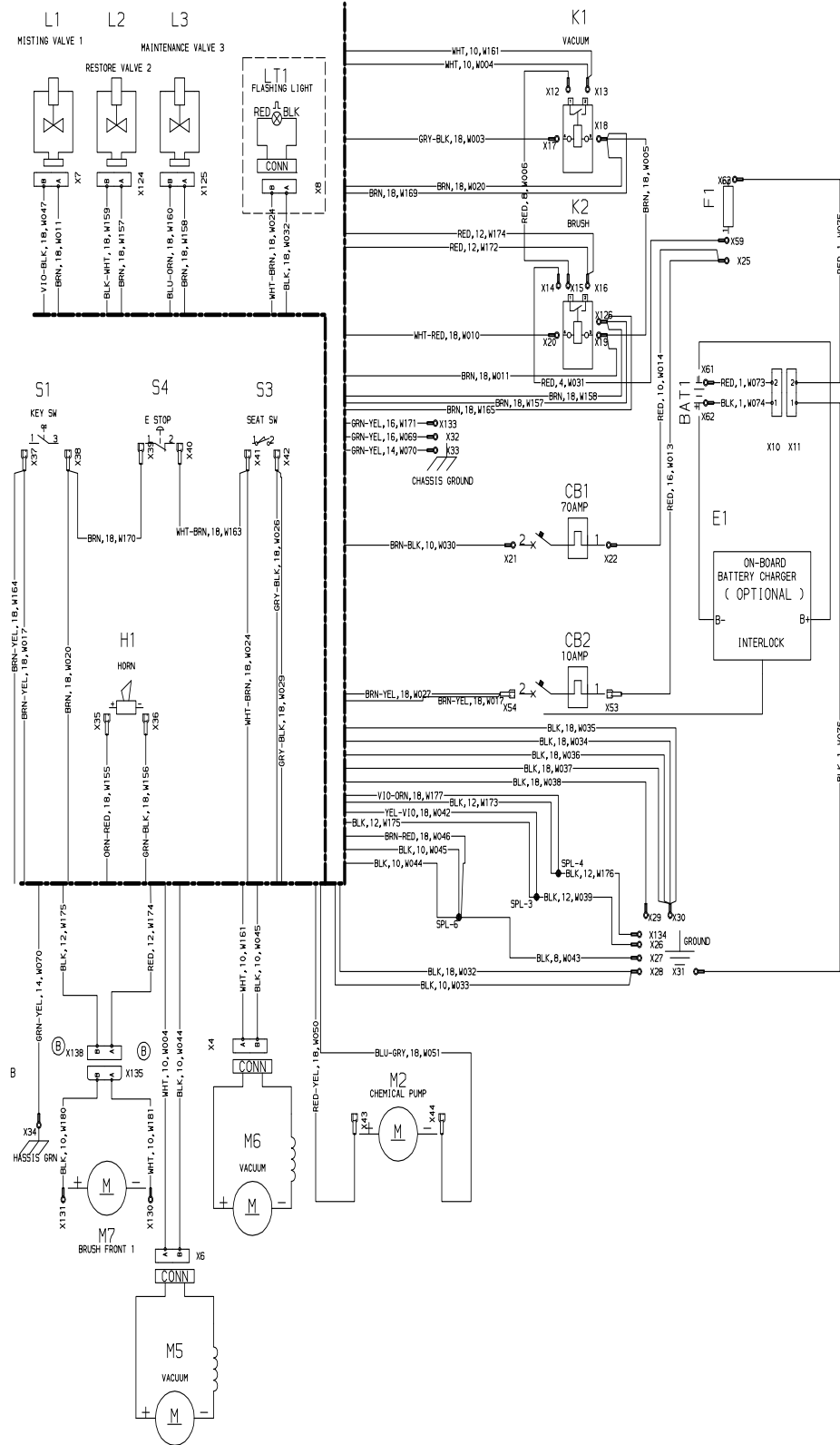

# Options and Accessories

## Options

1. Battery

6V 312 AH AGM,

6v420 AH WET



2. Shelf Charger (Portable)

24V auto 20 AMP  
120 VAC/60HZ

24V auto 25 AMP  
120 VAC/60HZ

24V auto 36 AMP  
120 VAC/60HZ

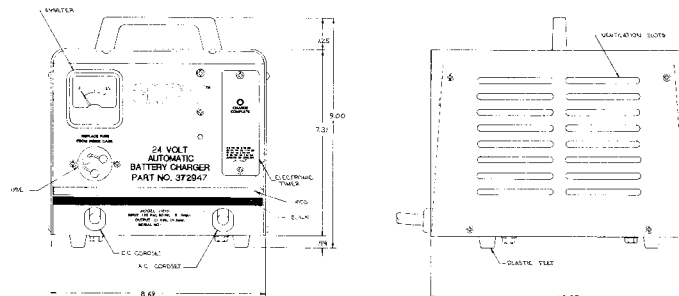
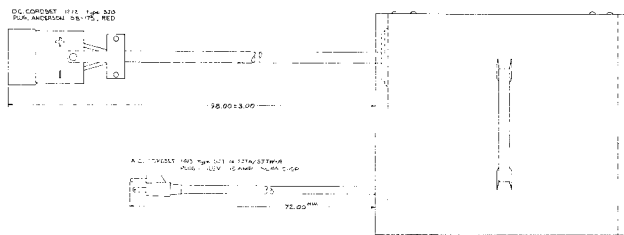



## Accessories

1. Warning Beacon kit

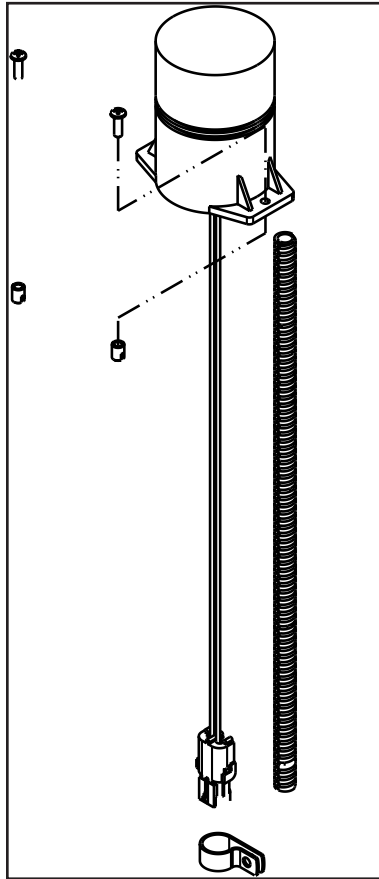

2. Battery Watering Kit

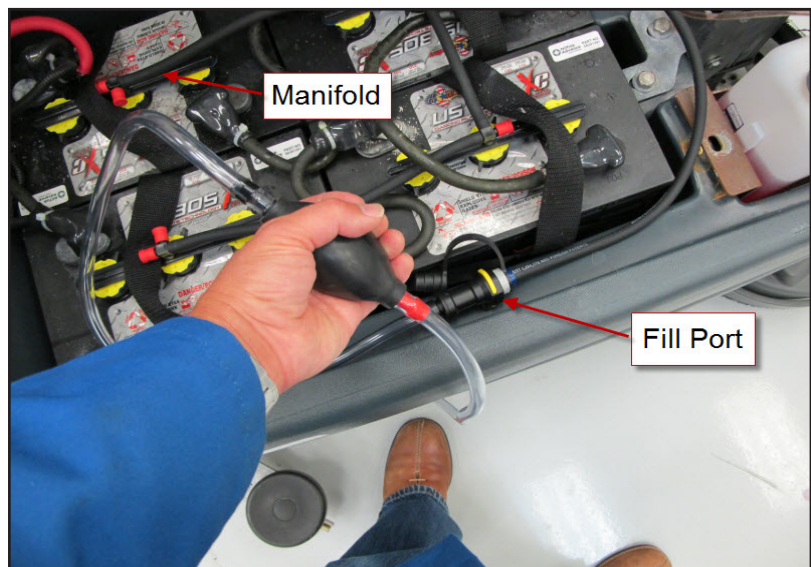
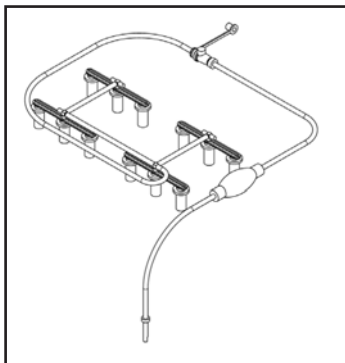

3. Chemical Bottle Assembly

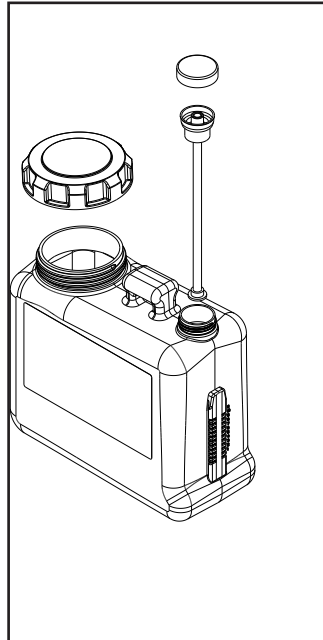

4. Battery Fill indicator



- 5. AquaWand Carpet Scrub Wand 13 and Accessory hose assembly

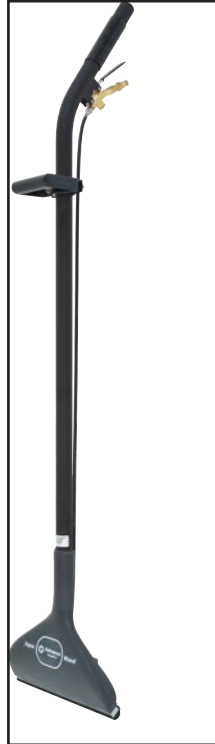

# Recovery System

---

## Functional Description

### Recovery System—Vacuum General

During extraction, dirty water is lifted out of the carpet pile by airflow created by two 3 stage 24V vacuum motors. See Figure R-1. The dirty water and air enter at the two vacuum pick-up tools through their small narrow shoe openings that contact the carpet surface. A hose is connected to each shoe to direct water to the Recovery Tank hose that is connected to the Recovery Tank. Once inside the Recovery Tank, the heavier water falls to the bottom of the tank while the air continues through the shutoff float, vacuum motors and is exhausted out of the exhaust tube at the bottom of the vacuum motor housing.

The vacuum system uses a shutoff float that prevents the tank from being overfilled and also stops any water from being sucked into the vacuum motors. This shut-off function works when the float ball reaches its tank full level and the ball becomes seated in the float housing. The added restriction to the vacuum airflow causes a large electrical current load change (lower Amps) to the vacuum motors. Sensing the lowering of the vacuum circuit current load, the main controller A1 automatically shuts off the vacuum and cleaning systems and displays “FULL” on the hourmeter/status display.

### Recovery System Circuit Description

The main controller turns on the vacuum motors by energizing the vacuum contactor. The vacuum contactor is provided battery positive voltage on one side of the coil through the key switch. To energize the contactor, the main controller completes a path to ground (battery negative) on the other side of the coil through an internal switch. When the vacuum contactor is energized, the contacts close and supply battery positive voltage to each of the vacuum motors. The vacuum motors are hard-wired to battery negative using a specially calibrated ground wire that has a specific resistance along its length. The purpose of this special calibrated ground wire is to allow the main controller to calculate the current flowing through the wire by measuring the voltage difference between the two ends of the wire. Inside the main controller there is an “internal voltmeter” which is connected across the ends of these wire. As the current increases, the voltage measured increases. The main controller also drives the vacuum shoe lift actuator. It acts as a double throw, double pole switch to provide battery positive and battery negative voltage across the actuator wires in order to drive the actuator. It reverses the polarity to drive the motor in both directions.

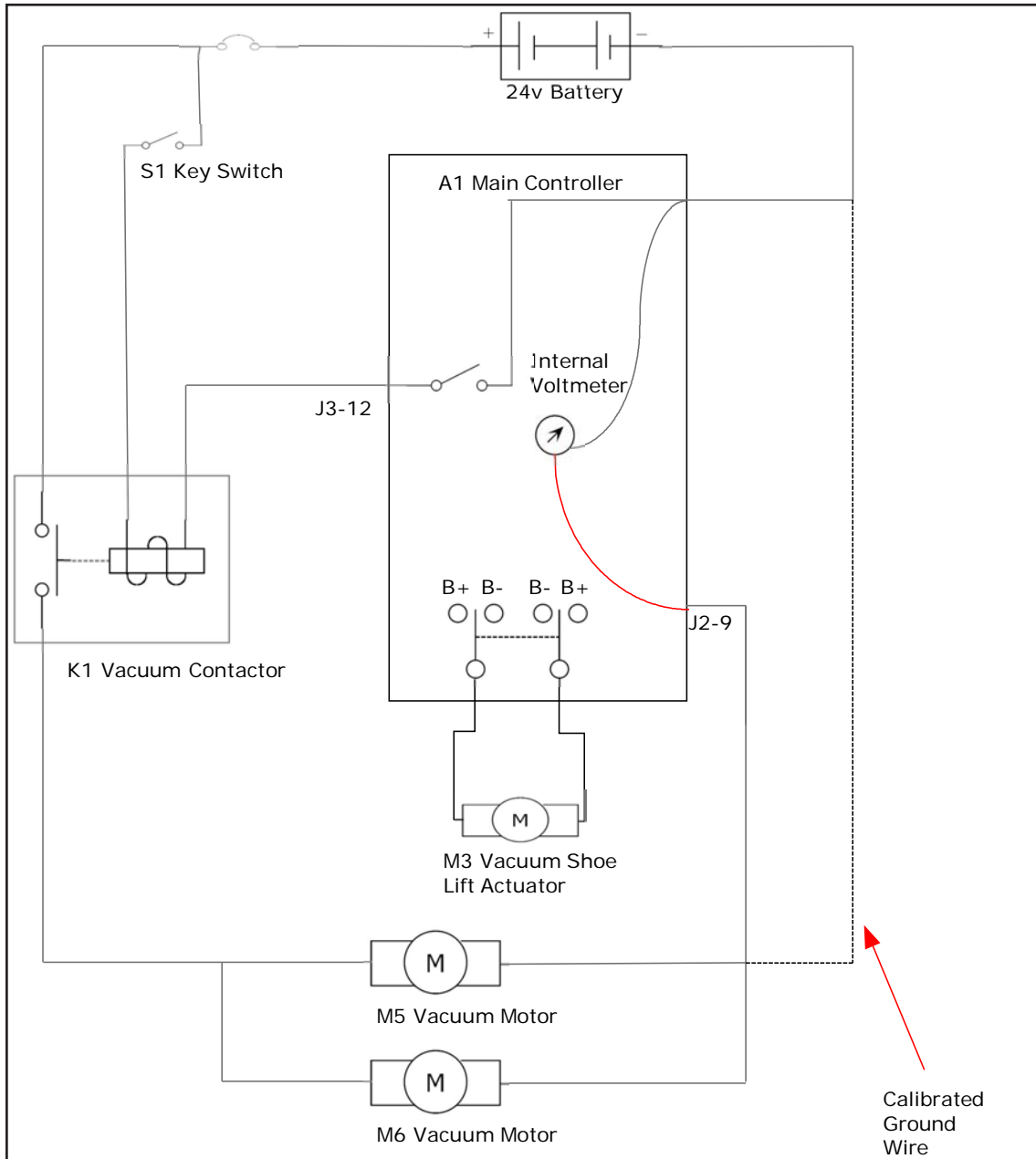

### Component Locations

- Recovery Tank and lid
- Recovery hose and dump hose
- Vacuum motor filter
- Strainer basket
- Tank Float shutoff
- Vacuum motor
- Wet Port
- Dry Port
- Vacuum Shoes
- Vacuum shoe lift actuator
- K1 vacuum contactor

See Figure R-1.



Recovery Tank recovery hose and dump hose



Vacuum shoe



Vacuum motor filter



Tank Float Shutoff



K1 vacuum contactor



Strainer Basket

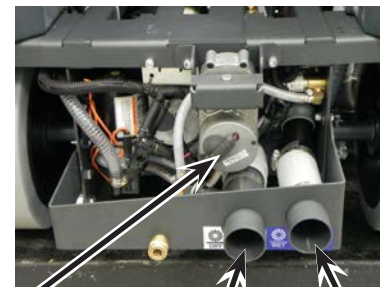

Dry Port

Wet Port

Vacuum shoe lift actuator



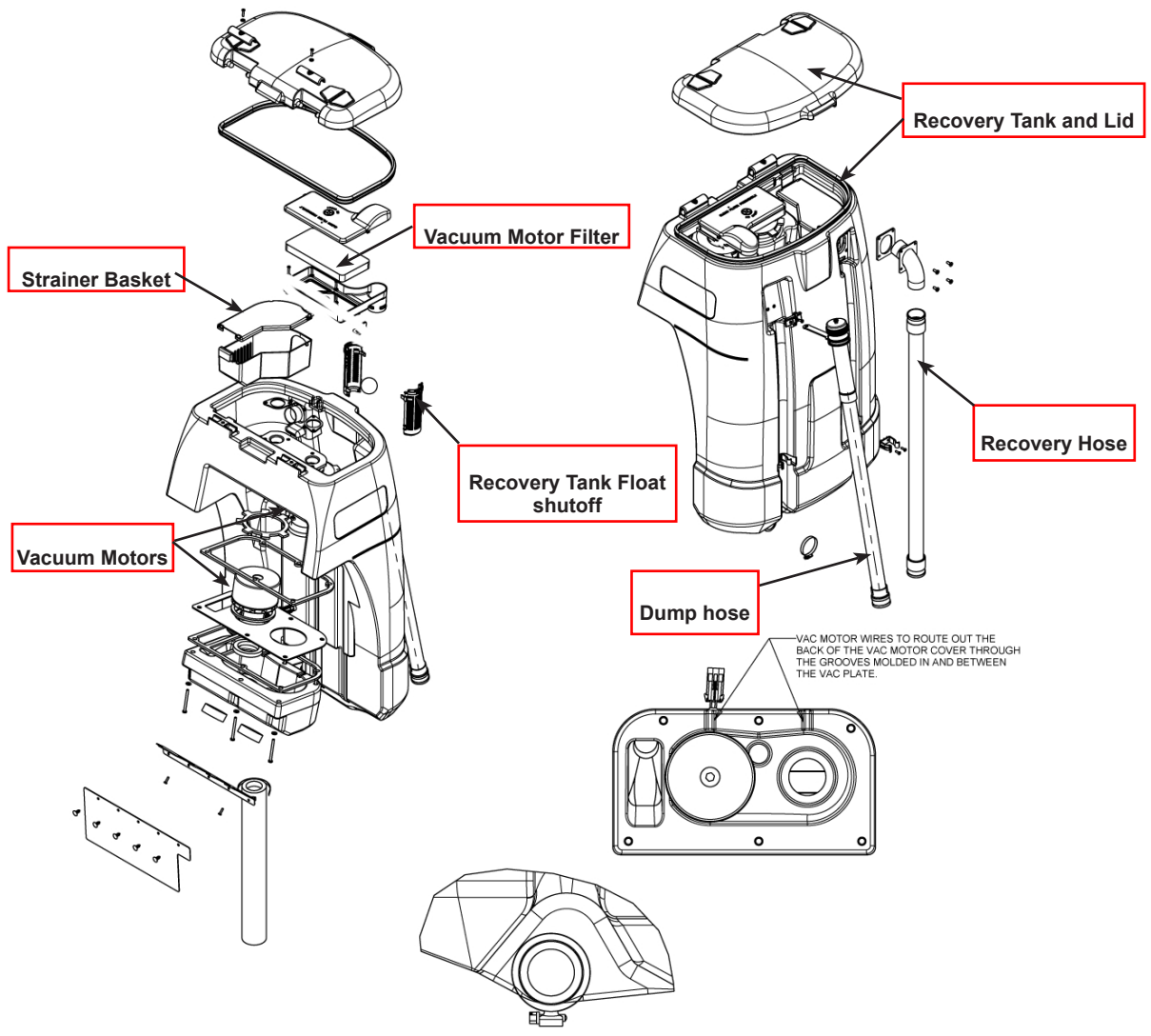

Figure R-1

## Maintenance and Adjustments

### Recovery System Service Maintenance Checklist

Whenever there is a vacuum problem, check over the entire system. Use the checklist below as a guide to thoroughly check the vacuum system.

- Clean built-up dirt from the inside of both vacuum pick-up (shoes) tools.
- Inspect the vacuum motors duct (plenum housing) cover gaskets, clean foam air inlet filters and screens.
- Inspect the hose between the pick-up tools and the recovery tank, rinse any built-up dirt from the hoses. Replace the hose(s) if it is kinked or damaged.
- Inspect and make sure the gaskets on the recovery tank covers are sealing and not damaged.
- Inspect and clean the vacuum motor float cage, float ball and shut-off seat.
- Make sure that the recovery tank drain hose cap seals airtight.

### Vacuum Filter and Float Cage Maintenance

To inspect and clean the vacuum motor foam filter just lift open the tethered Vac Duct Cover. Remove the filter by pulling it out from the housing opening. Clean the filter by vacuum or washing it out in warm water.

 *Note: The filter must be completely dry before reinstalling.*



To inspect the vacuum shut off float just open the recovery tank cover to access the float cage assembly (back center in recovery tank). The cage openings must be kept free of any debris that can restrict maximum airflow. To keep it clean, wipe off with a rag regularly or remove and flush with water. The cage is a two piece design and can be snapped apart to separate.



The Recovery Tank Strainer Basket requires frequent cleaning to avoid clogging the system. Remove the strainer by lifting it upward off the mounting tab.

Completely rinse the basket with clean water and remove any debris that may still cling to the inside or outside.



Re-install the Basket by pushing the mounting tab into position and snapping it into place.



## Troubleshooting

When extracting and experiencing little or no (below normal) waste recovery water entering the recovery tank, the vacuum system is not working properly. When the vacuum system performs poorly, it is usually because of one of the following problems:

**Vacuum Leak(s)** – Air flowing into the vacuum system past a bad gasket or leaky hose, damaged tank, or a leaky drain hose cap. A vacuum leak below the water line will create turbulence in the recovery tank, causing water to enter the vacuum motor.

**Restriction(s)** – Anything that blocks the flow of air through the system. Restrictions may also be caused by built-up debris in the pick-up tools, vacuum hoses, float cage or wherever the airflow is forced to make a sharp turn. Both leaks and restrictions decrease the quantity of air flowing through the pick-up tools. This results in less pick-up power.

**Vacuum Electrical Components** – The vacuum motors and vacuum solenoid are monitored by the main controller to detect any system function failures (error codes). Detected error codes are displayed on the hour meter LED display as they occur.



*Note: Reference the Main Control Board Troubleshooting Guide in the Electrical System of this manual for specific fault descriptions and service repair actions.*

## Removal and Installation

### Vacuum Motor(s) Removal

1. See Figure R-5. Remove the vacuum motor Cover (A) that is secured to the recovery tank by six (6) Screws (B).
2. Separate the wiring harness from the motor and lift motor out from it's mounting cavity.
3. Inspect all the vacuum/recovery system Gaskets, (C, D) also clean the vacuum motor(s) Foam Filter (E), Strainer basket (F) and Hoses.
4. Inspect the carbon motor brushes, if less than 3/8" (10mm) in length replace.

 **Service Note:** The hinged Tank Cover can easily be separated from the vacuum Duct Cover by removing the slotted Pin (use a flat blade screwdriver).

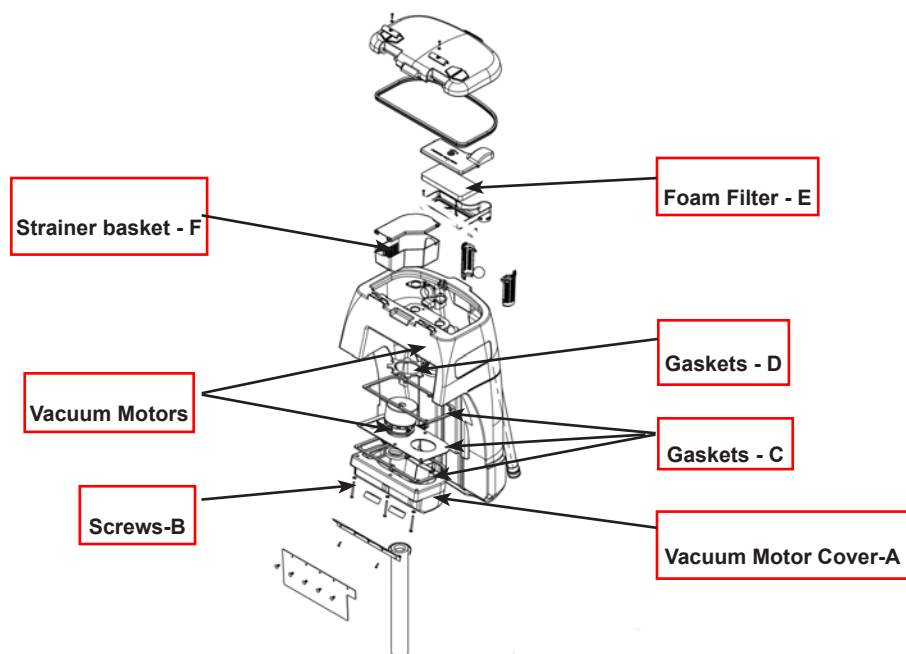

Figure R-5

### Recovery Tank Removal

Drain the recovery tank by using the drain hose.

See Figure R-6.



Figure R-6

Remove the Recovery hose from the bottom connector bracket.



Swing open the operator seat platform (set the prop rod) and pull apart the vacuum motors' harness connector (located left rear of battery compartment).



Open the hinged recovery tank Cover and grip the top inside edge of the tank and pull straight up to complete the tank's separation from the machine's solution tank/chassis assembly. Next guide the tank off the rear of the machine while taking care to prevent crushing of the vacuum hose, then lay the Tank down onto the floor.

 *Note: There is some weight to the tank assembly. Be careful when lifting it off. Ask for an extra helper to assist.*



## Vacuum Shoes Removal

1. With the Master Key Switch off, the vacuum shoes should be checked and cleaned daily.
2. See Figure R-7, Disconnect the vacuum recovery hose (AA) from the vacuum shoe (BB). Then pull up on the gold chain (CC), and slide the shoe (BB) away from the Shoe Support Weldment (DD).

 *Note: The procedure is the same for both shoes, however, the RIGHT shoe must be removed before removing the LEFT shoe.*

3. Rinse the shoe housings with warm water to remove any build up of string, hair or carpet fibers. Then reinstall shoes in reverse order of removal.

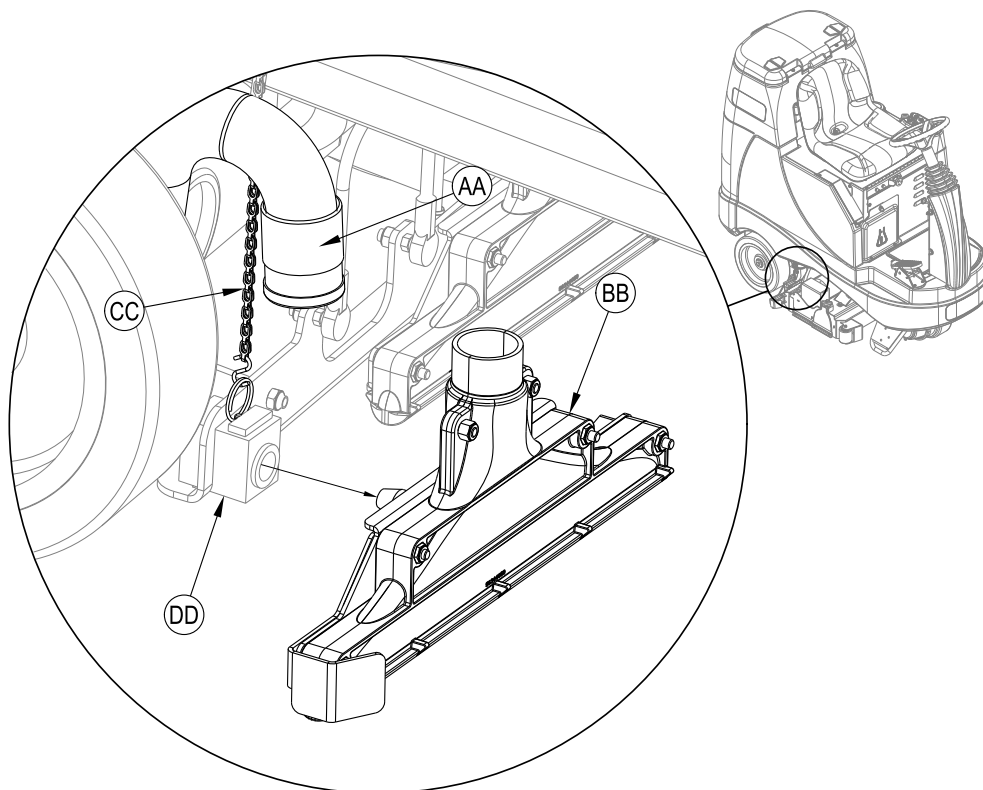

Figure R-7



Lift the chain to remove the Shoe from the shoe support weldment.



## Recovery System Wet and Dry Pickups—Accessory Port

### Pickup Connectors

The pickup connectors are located on the lower rear part of the machine. This area is best accessed by removing the Recovery Tank but is also accessible by lowering the connector bracket as shown in the photo. Both Wet and Dry connectors are part of the connector bracket.

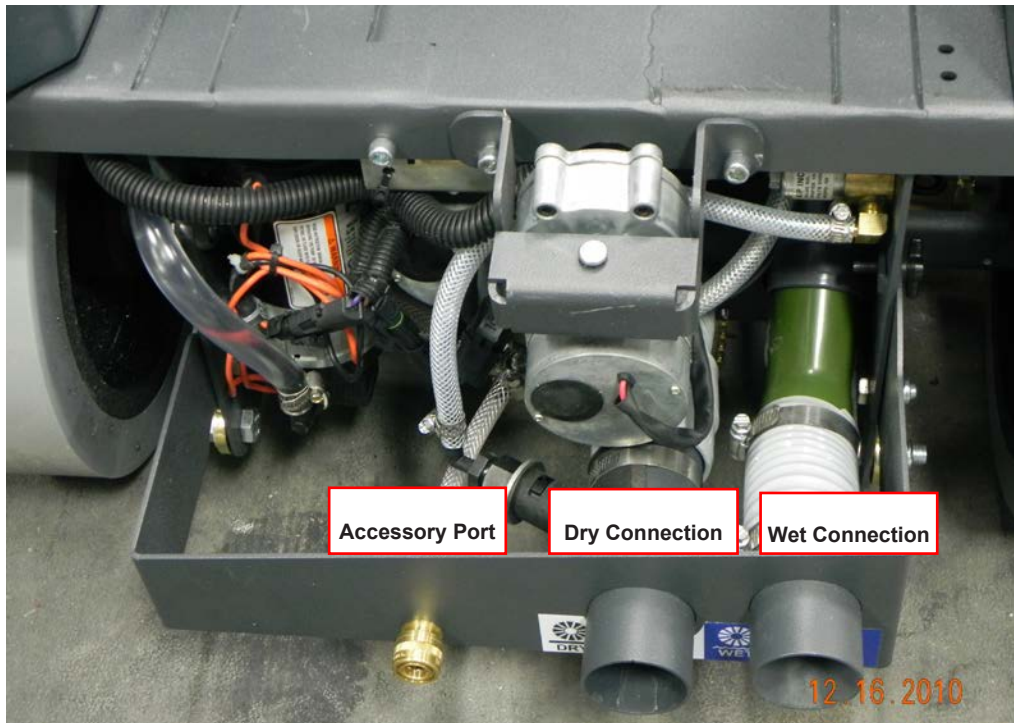

*Lower Recovery System Connectors - Recovery tank removed*



*Wet connection to Recovery Hose*

### **Wet Connection**

When extracting connect the Recovery hose to the WET connection. When the Extraction shoes pull moisture from the carpet the liquid is transported through the hose to the Recovery Tank through the WET Connection. See photo on previous page. SEE OPERATOR'S MANUAL section OPERATING MACHINE–EXTRACT MODE.

### **Dry Connection**

When operating in the Dry Sweep mode, connect the Recovery hose to the DRY connection. In Dry Sweep mode the vacuum system pulls dust from the hopper area and lightly sprays a water mist into the airstream to dampen dust as it sends it through the DRY Connection and hose to the Recovery Tank. SEE OPERATOR'S MANUAL section “OPERATING THE MACHINE–SWEEP MODE.

Large debris is either thrown into the hopper on the back of the deck, or captured in the strainer basket as it enters the Recovery Tank.



***Hose Connected to DRY Connector***

1. A misting nozzle is installed into the side of the Misting chamber adaptor. The nozzle assembly can be removed to access the misting nozzle itself.



2. Turn and pull the misting nozzle assembly from the misting chamber adaptor.



3. Again, turn and pull the nozzle from the misting nozzle assembly. Clean or replace the nozzle and re-install into the assembly.

Install the misting nozzle assembly into the Misting chamber adaptor.

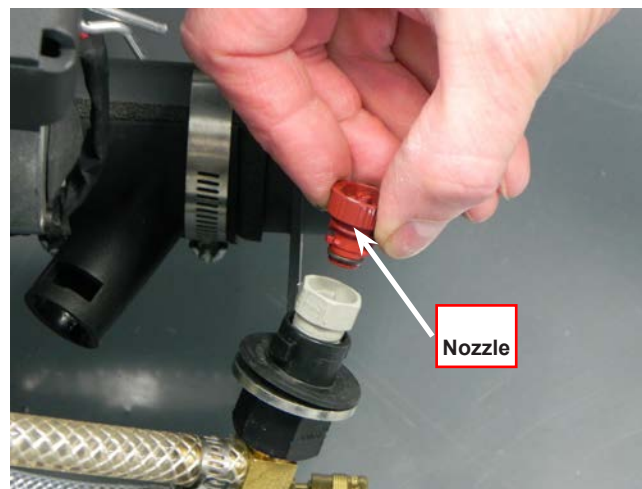

### Accessory Port—Using Attachments

Optional attachments are available for detail or upholstery cleaning with an accessory hose.

1. Disconnect the recovery hose and connect the accessory hose to the Recovery Hose.
2. Attach the SOLUTION connection from the accessory hose to the accessory port located next to the DRY pick-up connection.
3. While not seated in the operator's seat Turn ON the master key switch and press the VACUUM ON/OFF Switch. The Vacuum motor will run continuously until the switch is pressed again to turn it OFF.

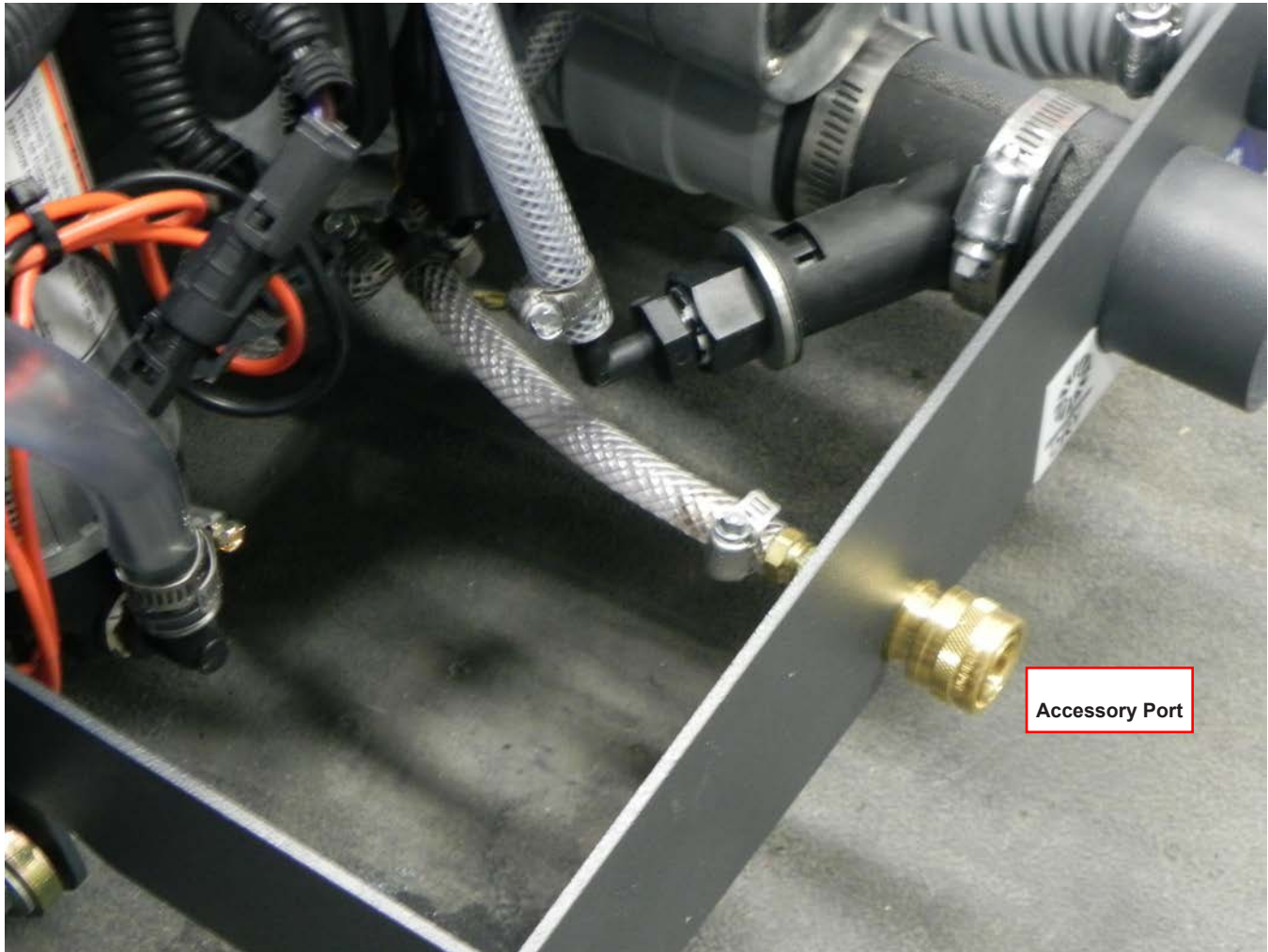

*Accessory Port on Recovery System lower panel – bottom rear of machine*

## Recovery Shoe Lift Actuator Removal and Adjustment

1. Remove Batteries and Battery tray leaving the open chassis.



2. Access the actuator opening (s) in the chassis.



3. Working from the rear of the machine, Connect the actuator power cord adaptor (part # 56407502) to the harness connector for the Shoe Lift Actuator.

Attach the Positive and Negative leads to the corresponding terminals on a Battery.

Run the Actuator to place the Recovery Shoes to their lowest (on the floor) level.

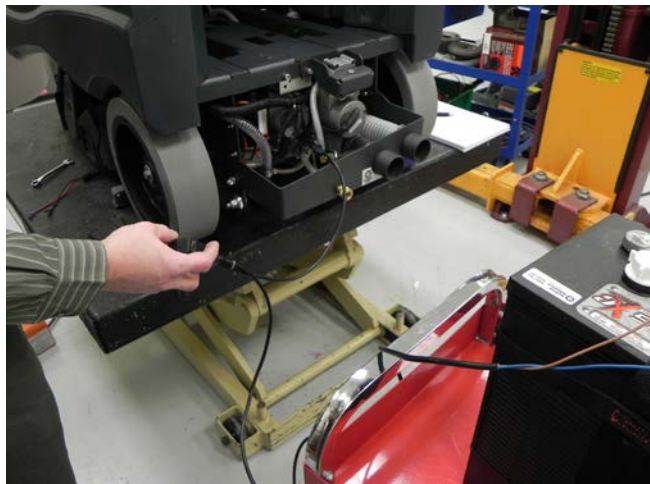

4. Remove the Retaining Clips from both ends of the lift pin that connects the actuator to the shoe lift cable.

Remove the connecting pin from the Actuator and frame.

Release the cable holding clip.



5. Remove the motor mounting bracket bolts.

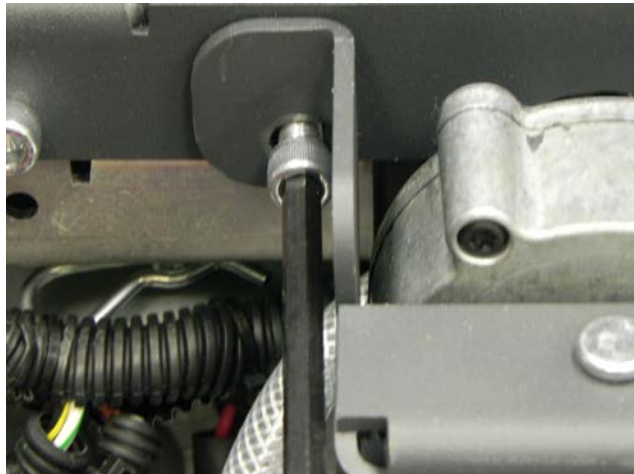

6. Remove the Actuator from the frame.

7. Reverse the process to reinstall. See Note!



*Note: When re-installing the actuator be very careful not to turn the actuator nut. If the nut has remained in it's original position the actuator can be reinserted and fastened into place without any other adjustments.*



### Actuator Drive Screw Tube Adjustment

The following instructions cover the procedure to adjust the drive nut (housing assembly) setting for the machine’s vacuum shoe lift actuator motor. Reference the chart below.

| Actuator Motor | Drive Drive Screw Tube IN | Drive Drive Screw Tube OUT |
|----------------|---------------------------|----------------------------|
| Shoe Lift      | 0.56 inches (14 mm)       | 2.81 inches (71 mm)        |

The “Drive Screw Tube IN/OUT Position” dimensions must be measured and adjusted before installing the actuator assembly on the machine.

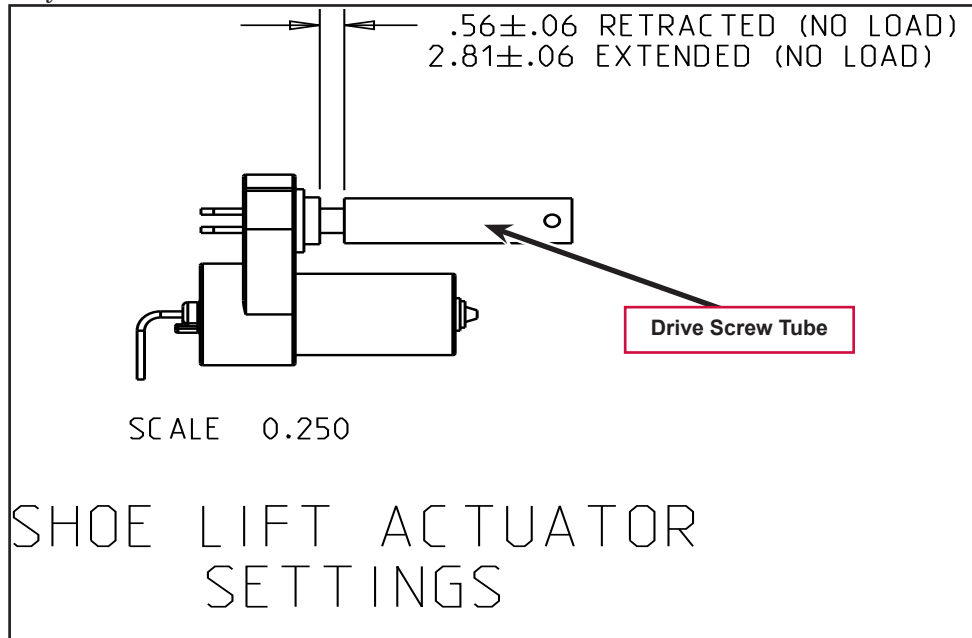

#### General Instructions for All Actuator Motors

1. This shows the special actuator power cord adaptor (part # 56407502) that is needed to connect a battery pack and actuator motor for setting the drive nut limit settings.
2. If the batteries are installed, open the machine battery compartment and disconnect the battery connector. The battery pack is needed to power the lift actuator motor to properly set the IN & OUT limit switches.
3. Connect the actuator motor to be tested to the power cord adaptor end. Then connect the alligator clips from the cord adaptor (red clip to the positive and black to negative) to battery connector or battery posts. The rocker switch is used to change the motor rotation in setting the correct drive nut dimension.

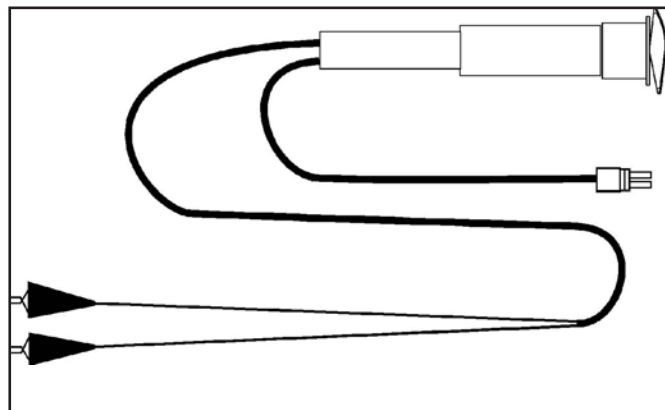

### Lift Actuator Drive Screw Tube Adjustment

1. With the drive screw tube removed from the threaded shaft, press the rocker switch on the power cord to run the drive motor all the way in until the motor stops.
2. Install the drive screw tube on the drive screw until the clearance between the end of the tube and the motor housing is approximately 0.56" (14 mm), which is the "In position".
3. Hold the Drive Screw Tube then press the adapter cord rocker switch to run the drive motor to the OUT position (wait until the motor stops).
4. Measure the distance between the end of the tube and the motor housing. It should be 2.81 inches (71 mm).
  - a. If the distance is not correct, remove the rubber adjuster cover from the end of the motor. Then rotate the nylon nut found under the cover with a 1/2" (13 mm) SOCKET (Not a screwdriver!). Turning the nut one click will change the distance approximately on tenth of an inch (2.5 mm).

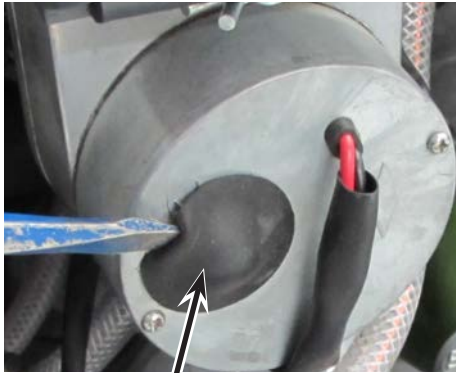

Remove Adjuster Cover

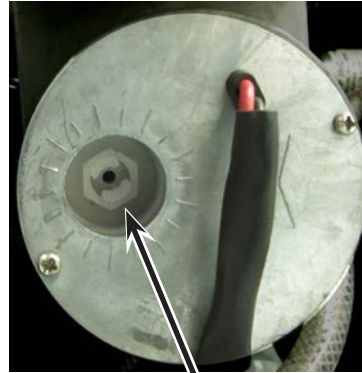

Rotate Nylon Nut to Adjust

 *Note: Use a 1/2" (13mm) socket to turn the adjuster.*

5. After each adjustment, hold the spring housing assembly, run the actuator IN & OUT and recheck the adjustments. Reinstall the adjuster cover.

## Specifications

|                    |            |   |
|--------------------|------------|---|
| Vacuum Motor(s)    |            | 2 of .75 HP (560-watt) three-stage              |
| Vacuum performance | Two Motors | Sealed: 66.92 in of Water ( kPa)                |
|                    |            | 1" Open-hole Aperture: 23.09 in of Water ( kPa) |
|                    |            | Max Airflow: 90.1 CFM / 42.52 L/s               |

## Special Tools

### Actuator Power Cord Adaptor (part # 56407502)

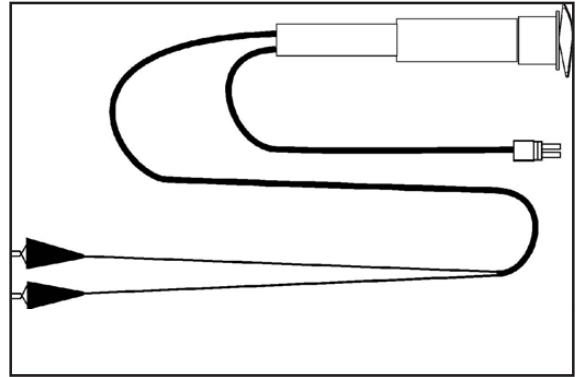

## Solution System

---

### Functional Description

See Figure S-1. A molded plastic (polyethylene) tank stores the machine's extraction solution. Total machine solution capacity is 29 gallons (109 L). Plumbed into the solution shut off Valve outlet is a serviceable spin off Filter Housing Assembly that keeps debris from entering the Solution Pump and solenoid valves (L1, L2 and L3). Also fitted is a short flexible Drain Hose to drain the tank for system maintenance. The electrical circuit that energizes the solenoid coils is activated through the operator panel buttons and main controller assembly A1.



*Note: See the Know Your Machine section in this manual for a detailed explanation of the complete solution operation modes.*

The three electrical solenoid valves L3 maintenance, L2 restoration and L1 misting control flow to the nozzles. The Maintenance nozzle directs the solution spray pattern onto the cleaning brush when in the maintenance extraction mode. The Restoration nozzle directs the solution in front of the cleaning brush when in the restoration mode (maximum flow). The misting nozzle directs solution to the misting chamber adaptor during dry sweeping, helping to improve dust filtration during dry pickup.

### Chemical Pump

The Chemical Pump is provided for automatically mixing detergent with water from the Solution Tank. When prespray mode is selected at the control panel, the deck is lowered and the shoes are retracted upward, if they are down. When the throttle is engaged forward, the solution pump, the brush motors, and the restore valve will be activated, while the Chemical Pump is activated at a specific rate. The Solution pump, brush motors, Chemical Pump, and the restore valve will turn OFF when the throttle is in reverse or neutral.

### Solution System Circuit Description

To get solution flowing, the main controller turns on the solution pump and energizes one of three solenoid valves. The solution pump is supplied battery positive power on one side from the key switch. To turn the pump on, the main controller closes a switch to battery negative to complete the circuit. There are three solenoids that control the solution flow. Each of the solenoids is supplied battery positive power to the key switch. To energize one of the solenoids and allow the solution to spray, the main machine controller completes the path to battery negative through an internal switch.

The Main Controller also operates the detergent (Chemical) pump. The two wires for the pump are wired directly to the Main Machine Controller. The Main Machine Controller supplies battery positive on one wire and battery negative on the other for a short period of time to stroke the piston in one direction. It then immediately reverses polarity and does it again to stroke the piston back in the other direction.

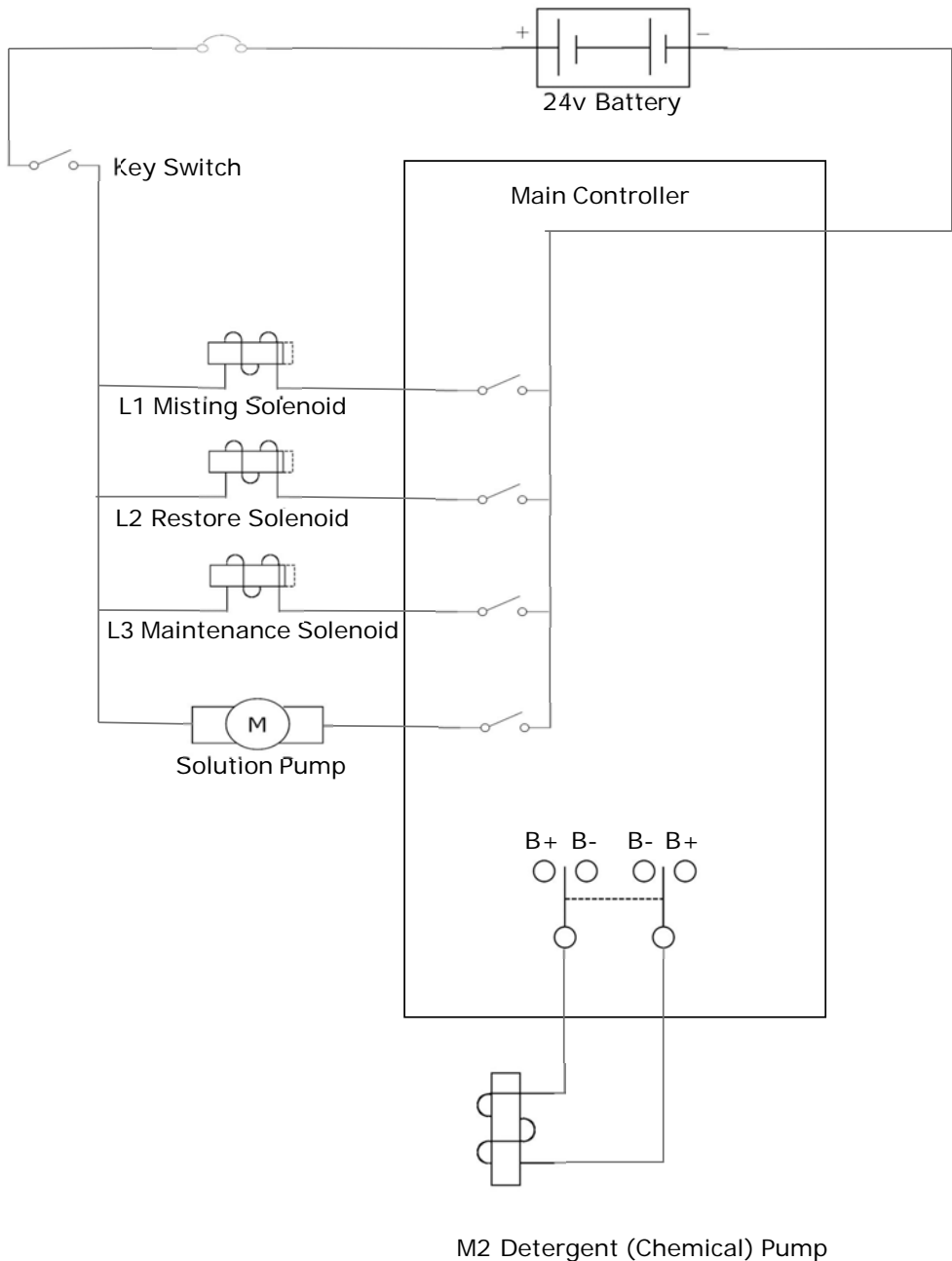

## Component Locations

The main components of the Solution System are (See Figure S-1, S-2, S-2a –2e):

- Solution / Detergent Cartridge
- Solution Filter
- Chemical pump
- Solution Pump
- Spray nozzles
- Solution Tank
- L1 Misting Solenoid
- L2 Restore Solenoid
- L3 Maintenance Solenoid

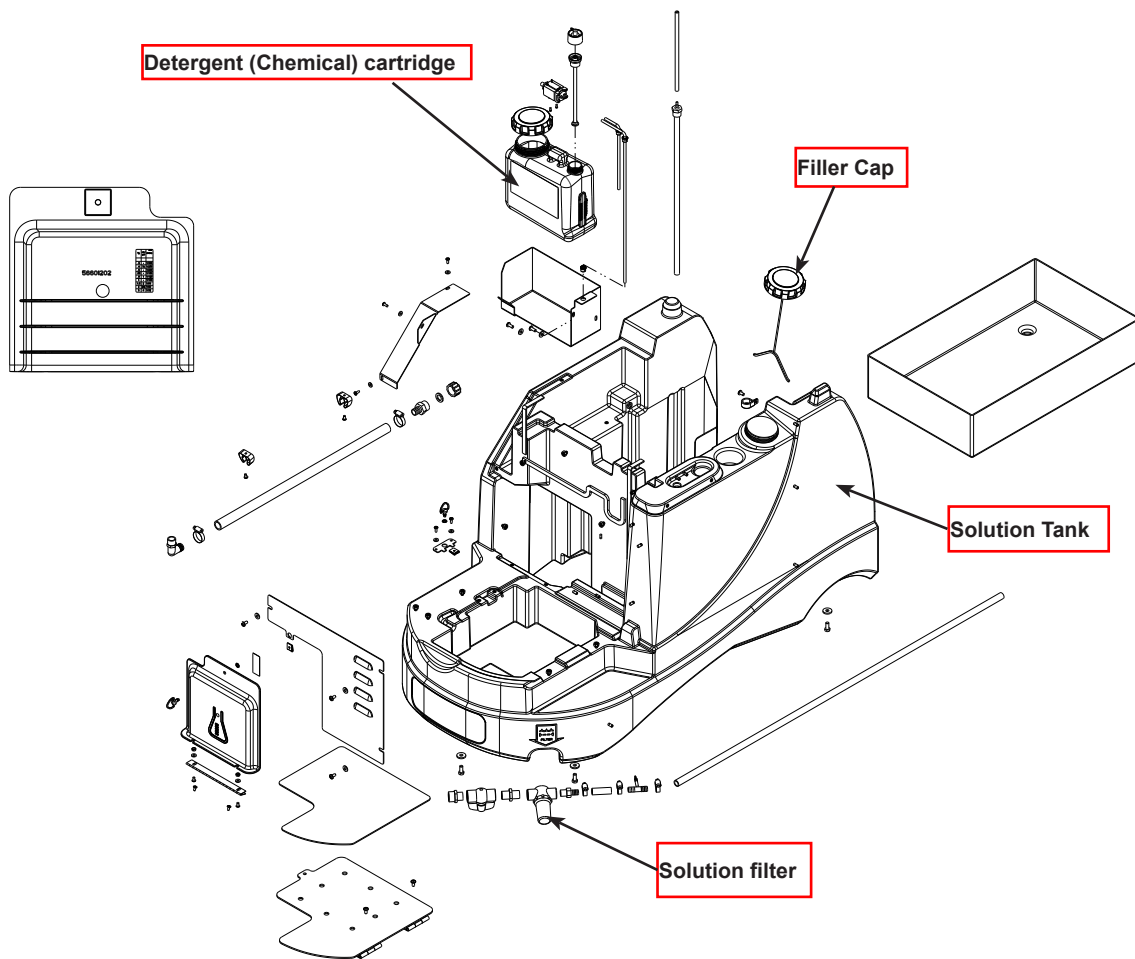

Figure S-1

Solution Filter and shut-off



Detergent (Chemical) Pump





Figure S-2

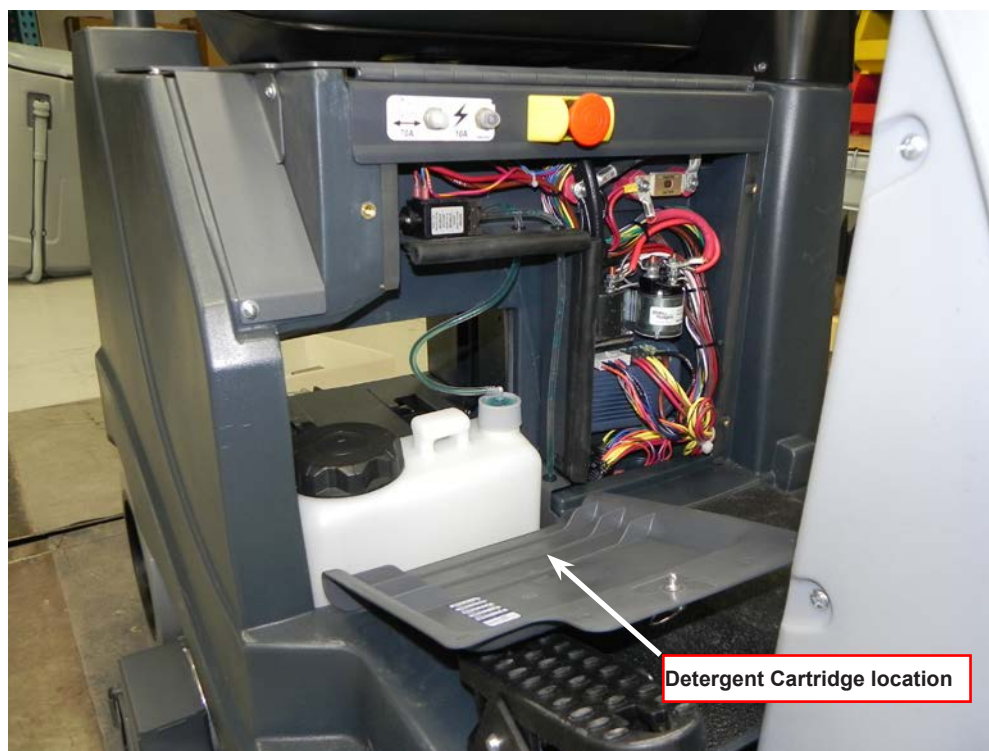

Figure S-2a



Figure S-2b

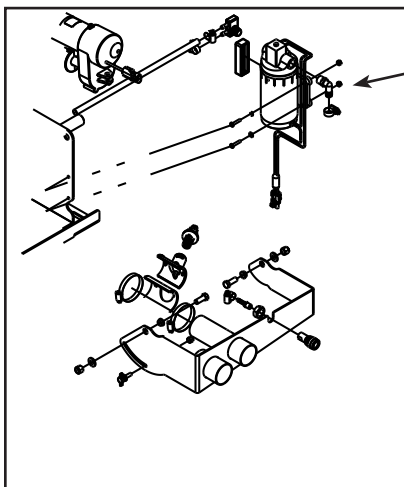
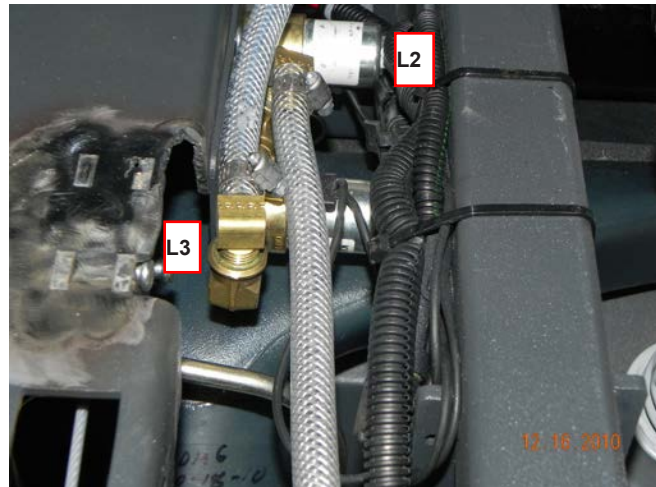

Figure S-2c

Solution Tank with Detergent cartridge access panel



Solution Solenoid Valves L2 and L3



Solution Pump

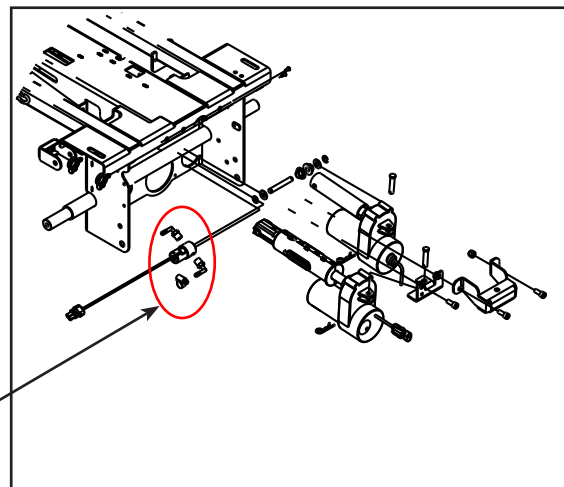

Misting Solenoid L1

Misting Spray Nozzle



Maintenance and Restoration  
Spray nozzles

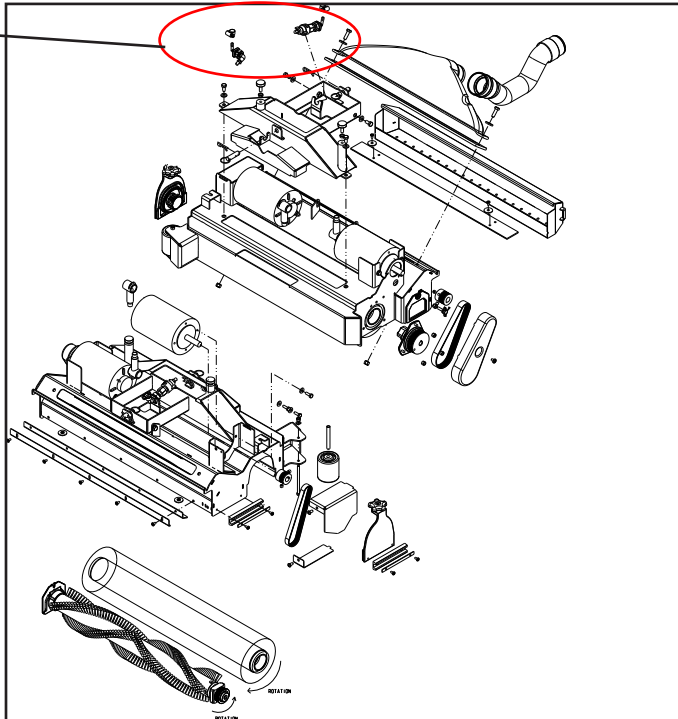



Figure S-2d

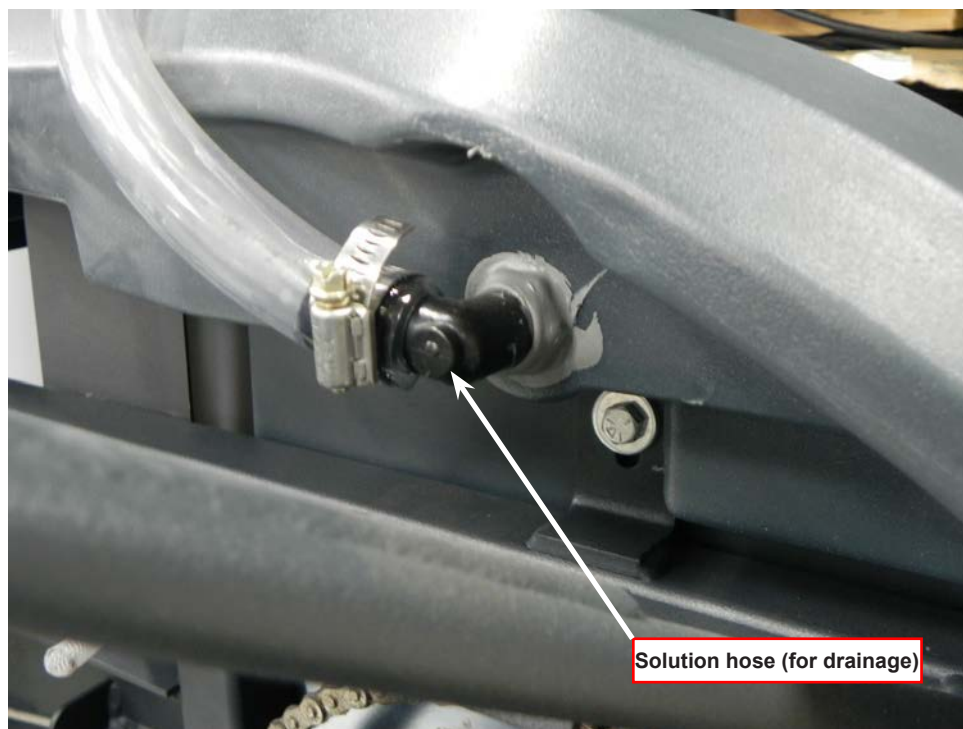

Figure S-2e

## Troubleshooting

### Mechanical / Electrical / Plumbing

| Problem                        | Possible Cause  |
|--------------------------------|---|
| Inadequate or no solution flow | No solution in the tank   |
|                                | Main solution flow shut off valve arm is in the closed position |
|                                | Clogged solution filter, hoses and solenoid valves              |
|                                | Defective solution solenoid coils (L1, L2 or L3)                |
|                                | Solution system fault in the main controller A1*                |

\*On all models the solution system's electrical solution solenoids L1, L2 & L3 (misting, restoration & maintenance modes) are monitored by the main controller A1 to detect any system function failures (error codes). Detected error codes from the main controller are displayed on the operator panel display as they occur.



*Note: Reference the Main Control Board Troubleshooting Guide in the electrical system of this manual for specific fault descriptions and service repair actions.*

## Maintenance and Adjustments

- **Solution Tank:** Weekly, empty the solution tank; remove the solution Drain Hose from its storage area (located underneath the left side of chassis). See figure S-2e. Direct the hose to a designated “Disposal Site” and flush the tank with clean water.
- **Solution Filter:** Remove and clean the inline Solution Filter. See Figure S-2d. To access the filter housing for removal, work underneath the middle front of the solution tank see molded “FILTER ” callout. No tools are needed to remove the filter (hand tighten only).



*Service Tip: The manual solution shut off valve (located next to the solution filter) must be placed in the full CLOSED position. This prevents loss of solution when servicing the filter strainer while there is solution in the tank.*

### **Purge Chemical Pump Weekly:**

1. Disconnect and remove the detergent cartridge. Install and connect a Cartridge filled with clean water.
2. Turn the Key Switch **(A)** ON. Press and hold the Detergent ON / OFF Switch **(C)** and the Solution ON / OFF Switch **(B)** for more than 2 seconds while the controller is in any mode except standby to initiate a purge cycle.



*Note: Once activated the purge process takes 10 seconds. See illustration on page 135 for Detergent System indicators. Normally one purge cycle is adequate to purge the system.*

### **To Reset the Detergent Counter**

As the detergent cartridge is used a counter counts down to keep track of the amount of detergent remaining. When the counter reaches it's lowest level, the control panel indicates that the cartridge is empty. When refilling or replacing the cartridge, the counter needs to be reset.

To reset the counter, turn the Key Switch (A) ON. Press and hold the Maintenance Mode Switch (G) and the Restoration Mode Switch (H) for more than 2 seconds while the solution and detergent are ON. The Detergent Reset Icon will display for 5 seconds. See illustration on page 135 for Detergent System indicators.

### **Detergent Ratio**

The pre-programmed ratio of detergent to water can be adjusted. There is a decal on the inside of the detergent cartridge access cover (see figures S-2 and S-2c) that will help to determine what ratio should be used for a specific detergent. To set the ratio, with the detergent system OFF, press and hold the Detergent ON/OFF Switch **(C)** for 2 seconds. The detergent indicator will flash and each press of the switch will cycle through the available ratios (1:64, 1:75, 1:100, 1:125, 1:150, 1:175, 1:200, 1:250). Once the desired ratio is displayed on the screen, stop and ratio setting will lock in after 5 seconds.

### DETERGENT SYSTEM PREPARATION AND USE

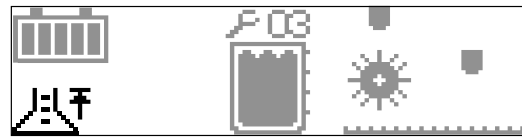

FULL (RESET)

Press and hold (G) & (H) for more than 2 seconds to Reset.

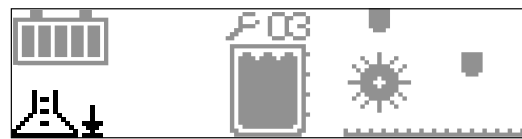

LOW DETERGENT



PURGE

Press and hold (B) & (C) for more than 2 seconds to Purge.

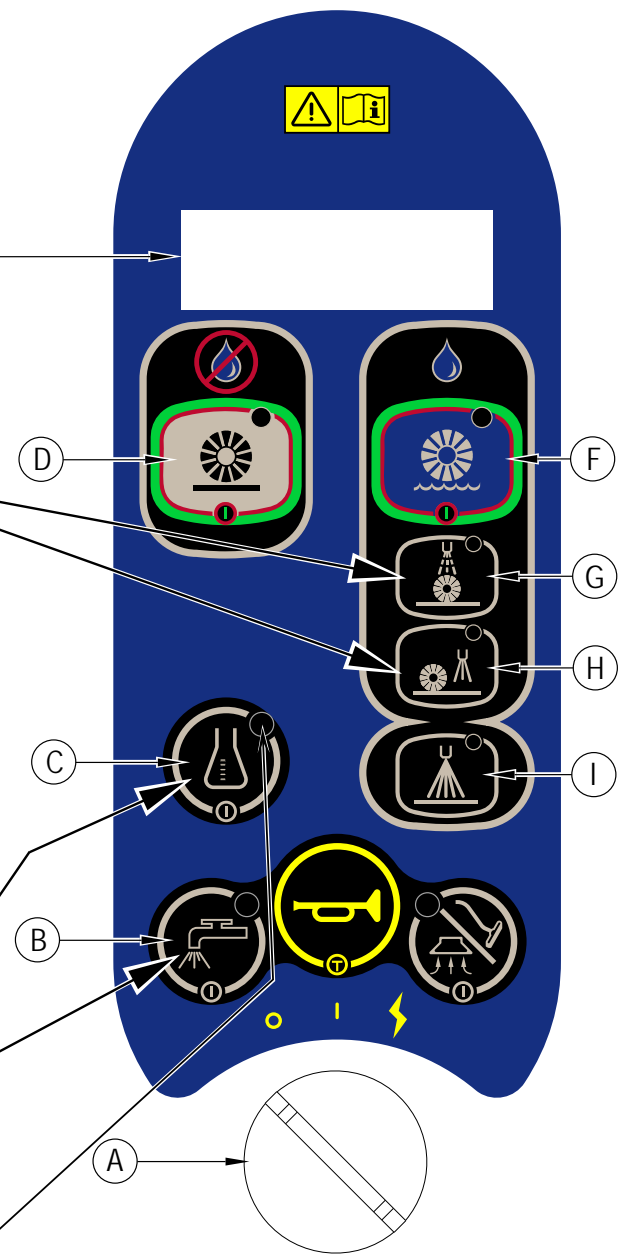

Detergent system is ON when indicator is ON.

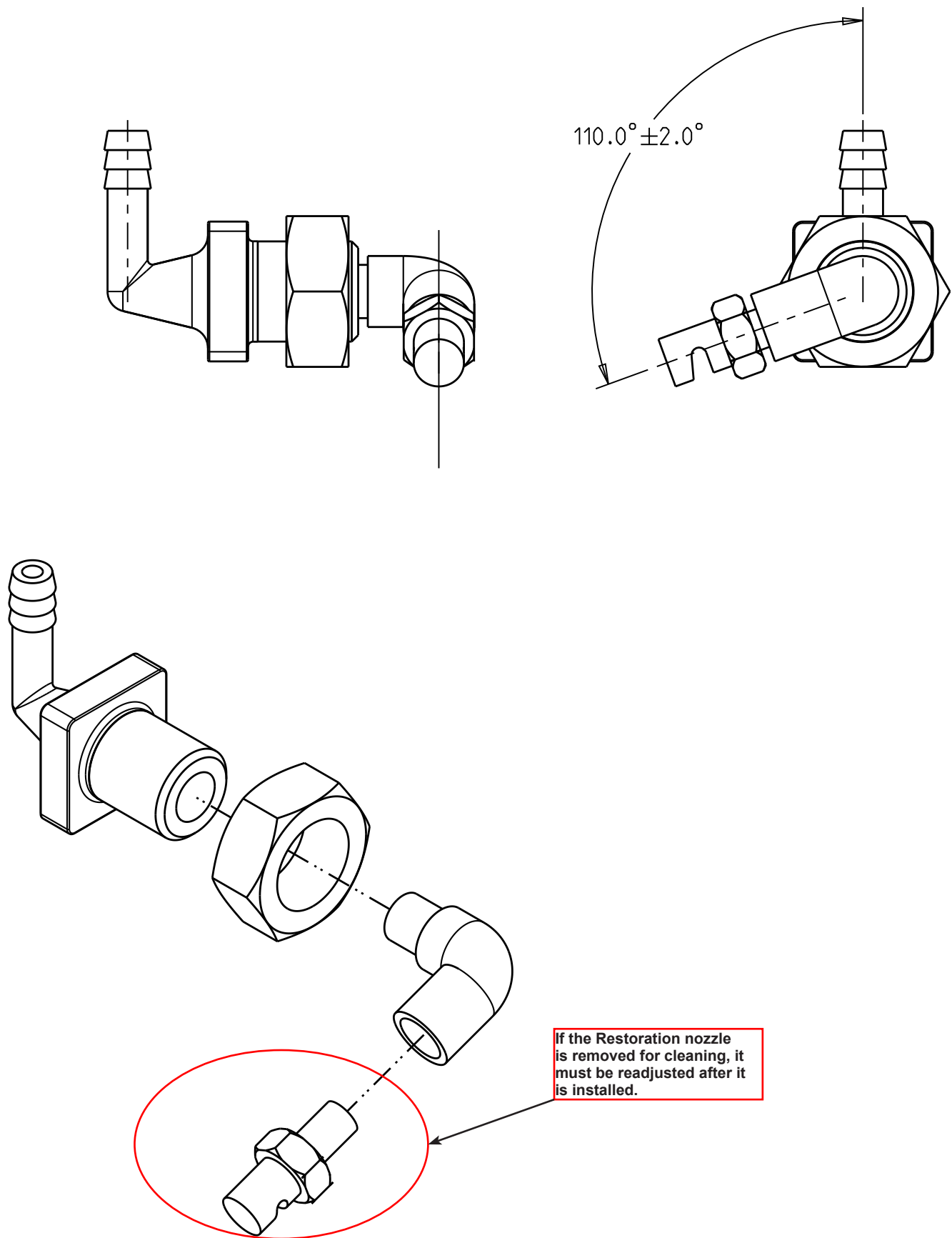

Figure S-3 Restoration Nozzle Assy

## Nozzle Maintenance

The nozzles are mounted on the Scrub Deck and shown in the Scrub System and the Chassis System. See Figure S-3a.

### To inspect and clean both nozzles.

1. To remove the Restore nozzle, remove the fastener nut that secures the nozzle and pull it from the brush housing slot with the hose still connected.

**⚠ Note:** *The entire Restore Nozzle assembly must be cleaned or the nozzle removed from the fittings and readjusted after the nozzle has been re-installed. See figure S-3.*

2. To remove the Maintenance nozzle tip, twist the nozzle a 1/4 turn to separate it from the nozzle body.

**⚠ Note:** *Nozzles should be inspected and cleaned once per week.*

3. Clean the nozzles by soaking overnight in a solution of full vinegar solution or properly diluted and handled muriatic acid solution to remove build up of chemical deposits.

**⚠ Note:** *Do not increase the size of the orifice by cleaning with a drill bit. This will adversely affect the nozzle pressure and spray pattern.*

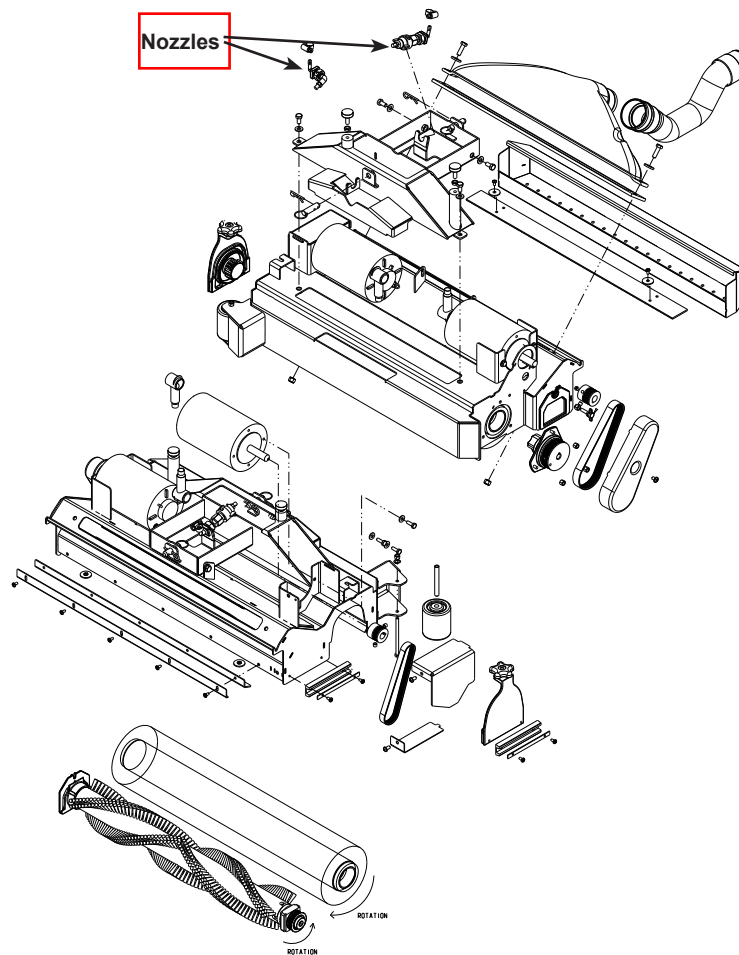

Figure S-3a - Nozzles are shown attached to the Scrub Deck

## Chemical Pump Removal

**⚠ CAUTION!** Disconnect the machine's battery pack connector before servicing machine.

1. See Figure S-5. Drain the solution tank using the drain hose or put the flow shutoff valve into its closed position to prevent the uncontrollable solution loss.
2. Remove the hose ends from the Chemical Pump inlet and outlet fittings.
3. Cut the pump wiring harness tie straps then disconnect the pump wiring connector.
4. Loosen the (2) screws that secure the pump assembly from underneath the pump and remove the pump from the electrical panel.

**⚠ Service Tip:** Use a long thin shaft #2 Phillips screwdriver to access the two pump mounting screws. When replacing the pump, install the mounting screws into the pump through the frame holes provided and then slide the pump with screws installed, into place. Tighten the screws.

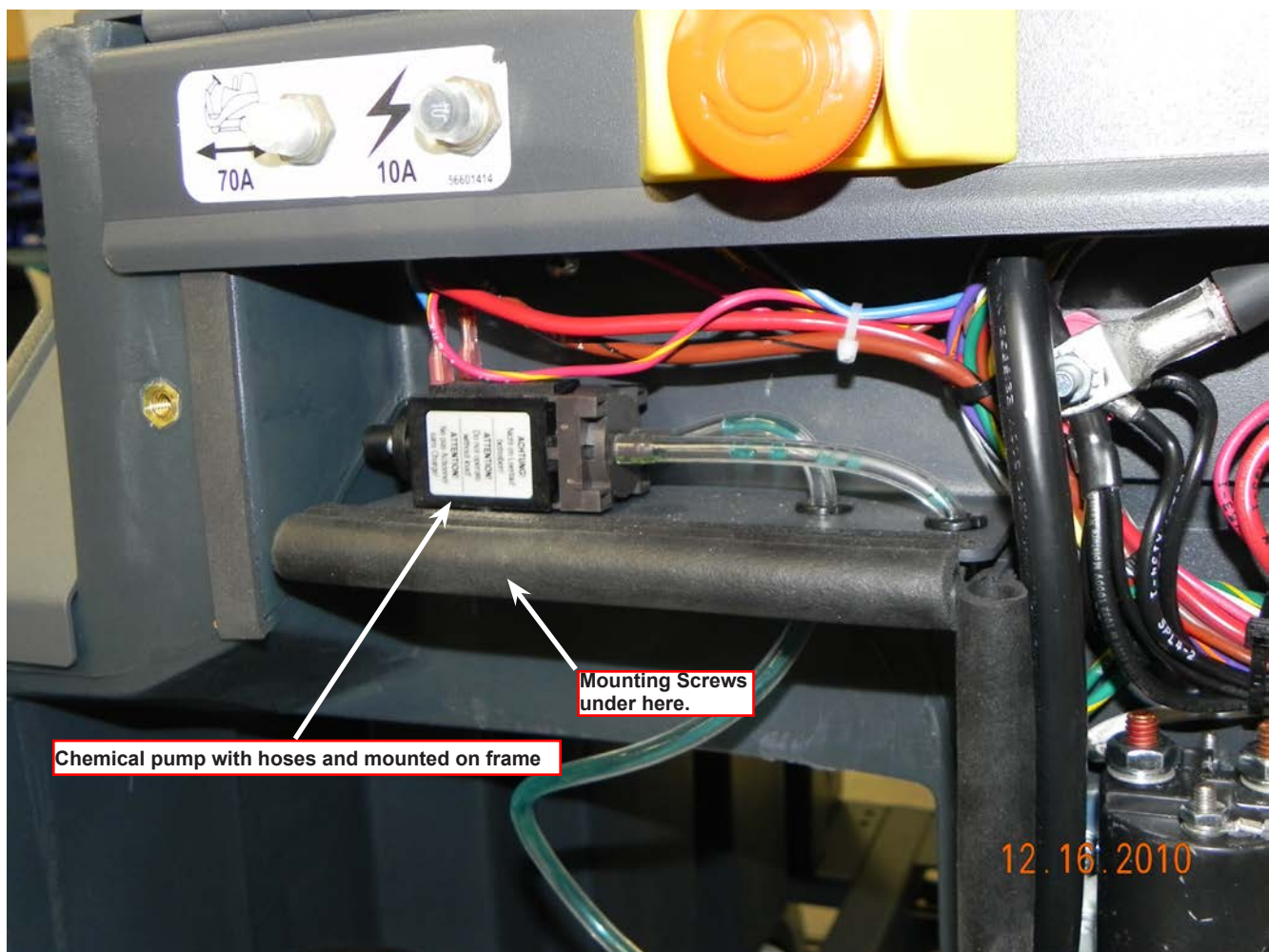

Figure S-5

## Solution Solenoid Valve Removal

1. See Figure S-6. Put the solution flow shutoff Valve (C) into its closed position and the scrub deck in the down position then disconnect the battery pack.
2. Block rear wheels to prevent machine from rolling then jack up the front of the machine 3-4 inches.

**⚠ CAUTION! Support machine with proper blocking for safety.**

3. Cut the necessary wiring harness tie straps used on the Solenoid Valve Assembly then unplug each valve from the machine's wiring harness.
4. Loosen the two screws that secure the solenoid mount bracket to the chassis, and slide the valve assembly off of the mounting screws.
5. Loosen the necessary hose clamps from the solenoid valve that needs service then pry the hoses off their fittings.
6. Remove the two screws that fasten the valve body to the mount bracket to complete removal.

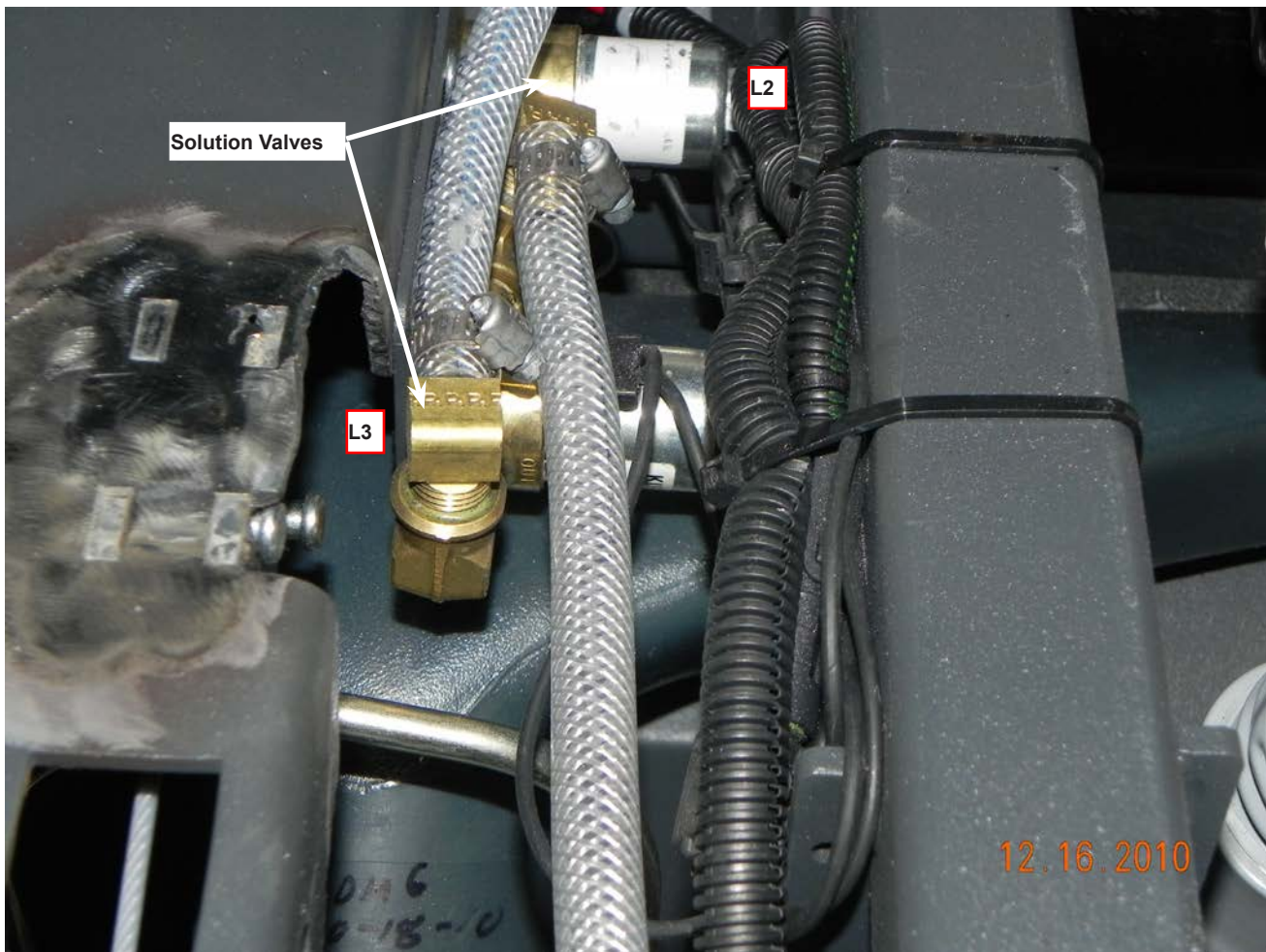



Figure S-6

## Solenoid Valve Disassembly and Cleaning

 *Note: See Figure S-7 for valve disassembly & cleaning.*

 *Service Tip: To just clean the valve assembly of any trapped debris it isn't necessary to completely remove it from the chassis mount bracket. Follow the short cut steps listed.*

1. Use a flat bladed screwdriver to hold the slot on the end of the Valve Spool (N) and remove the Nut (O). Next pull off the metal protective Cap (P), Coil (Q) and Washers (R). Use the screwdriver again and turn out (remove) the valve spool and Piston (S) (be careful not to lose any internal parts).
2. Thoroughly wash out all debris from the Valve Body Seat (T) then reassemble and test the solenoid for proper operation. Loosen the necessary hose clamps from the solenoid valve that needs service then pry the hoses off their fittings.

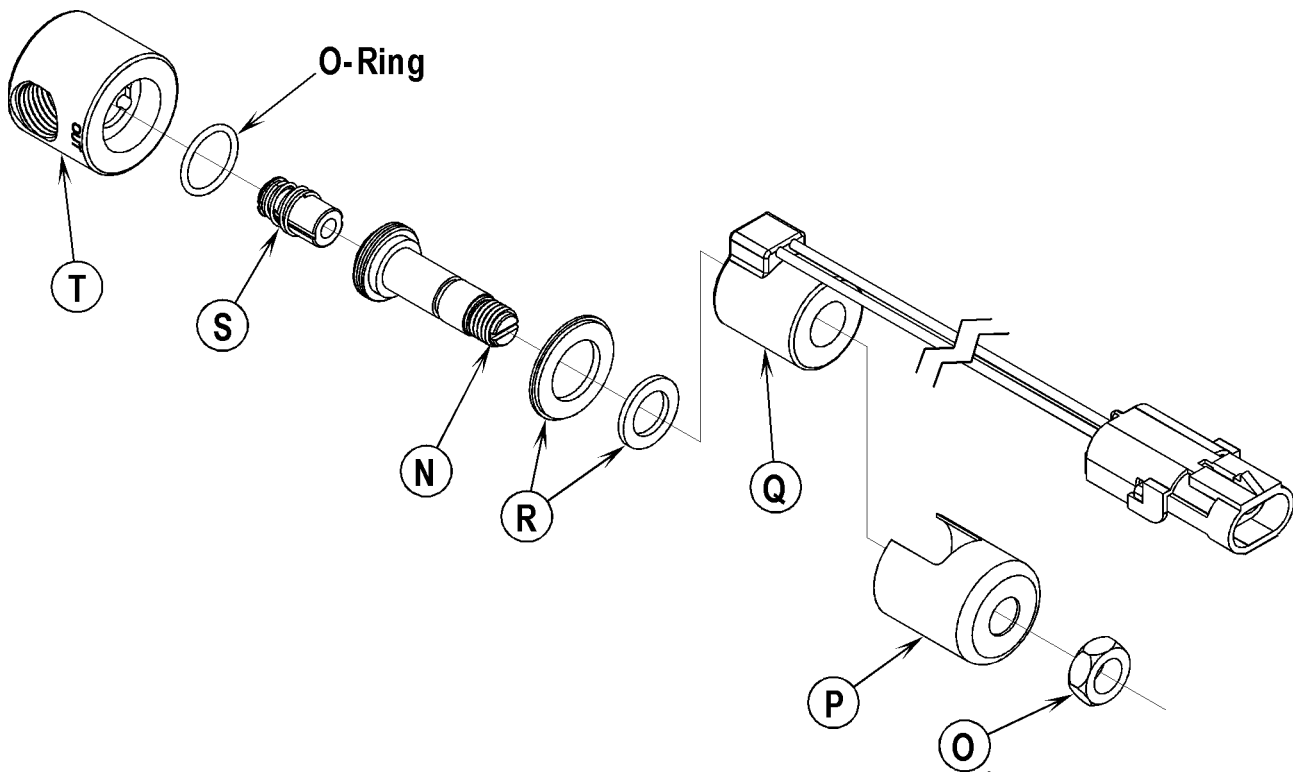

Figure S-7

## Specifications

|   |  |  |   |
|---|--|--|---|
| Solution Control                          | 1 Pump                                     |  |   |
| Solution Flow Rates                       | (1) Maintenance mode                       | .29 gal/min TR 10155                       |   |
|   | (2) Restore Mode                           | .8 gal/min TR 10155                        |   |
| Detergent Ratios Available Using Ecoflex™ | 400:1 = .25%<br>300:1 = .3%<br>256:1 = .4% | 200:1 = .5%<br>150:1 = .66%<br>128:1 = .8% | 100:1 = 1%<br>64:1 = 1.5%<br>50:1 = 2%<br>32:1 = 3% |
| Recycle System Available                  | No   |  |   |

| Nozzle and Pump Data  |   |
|---|---|
| Components  | Flow Rate GPM/Working Pressure  |
| Nozzle "Maintenance"<br>Spec. .033" orifice diameter<br>Brass<br>Nozzle tip I.D. 1/8 K1   | .29 GPM   |
| Nozzle "Restoration"<br>SPec. .091" orifice diameter - Brass<br>Nozzle tip I.D. 1/8 K 7.5 | GPM   |
| Pump Specifications   | Pressure relief switch opens at 100 PSI<br>Max. flow rate 1.6 GPM<br>Max. current 3.5A (average current 3.2A) |

# Scrub System

---

## Functional Description

### Cylindrical Brush System Overview

The ES4000 uses two cylindrical brushes that counter rotate to sweep up light debris and scrub at the same time. Each scrub brush is powered by 1/2 HP permanent magnet motors and driven by separate poly-V belt/pulley drives. Debris is swept into the hopper on the back of the scrub deck.

The scrub deck platform is raised & lowered automatically by an electric lift actuator motor (M4). The operation of the machine's scrub functions are activated when the operator selects (presses) either the Extract or Sweep panel buttons. The scrub brush pressure is electronically controlled to optimize scrub performance on a wide range of carpeted surfaces.

The vacuum motors and brushes run during all system cleaning modes. In DRY SWEEP mode, debris is swept into the hopper on the back of the scrub deck while dust and air are drawn toward the recovery tank. As the dirty air makes it's way to the recovery tank it passes thru the misting chamber adaptor where the misting nozzle applies a mist that helps to contain the dust.

### Scrub System Circuit Description

The main controller turns on the brush motors by energizing the brush contactor. The brush contactor winding is provided battery positive voltage on one side of the coil through the key switch. The main controller completes a path to ground on the other side, through an internal switch, in order to energize the contactor. When the brush contactor is energized, the contacts close and supply battery positive voltage to the brush motors which, are connected in parallel. The motors are hard-wired to battery negative using specially calibrated ground wires that have a specific resistance along their length. The purpose of these special calibrated ground wires is to allow the main controller to calculate the current flowing through the wire by measuring the voltage difference between the two ends of the wire. Inside the main controller there are “internal voltmeters” which are connected across the ends of these wires. As the current increases, the voltage measured increases. The main controller also drives the brush lift actuator. It acts as a double throw, double pole switch to provide battery positive and battery negative voltage across the actuator wires in order to drive the actuator. It reverses the polarity to drive the motor in both directions.

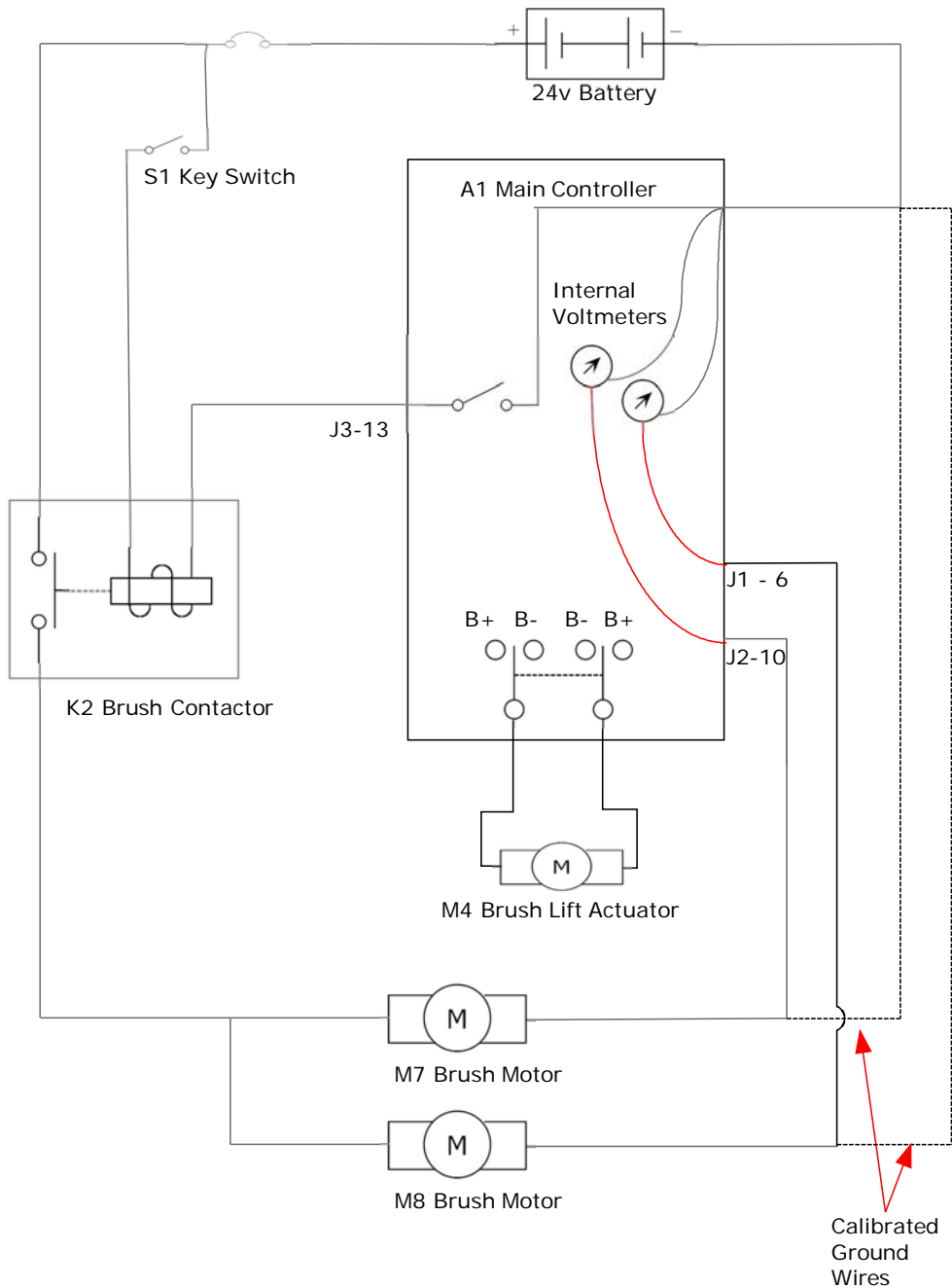

## Component Locations

The Scrub System main components are (Figure D-1):

- Scrub brushes (A)
- Brush motors (B) and drive belts (C)
- Debris hopper (tray) (D)
- Restoration Nozzle (E)
- Maintenance Nozzle (F)
- Scrub deck lift actuator (G)

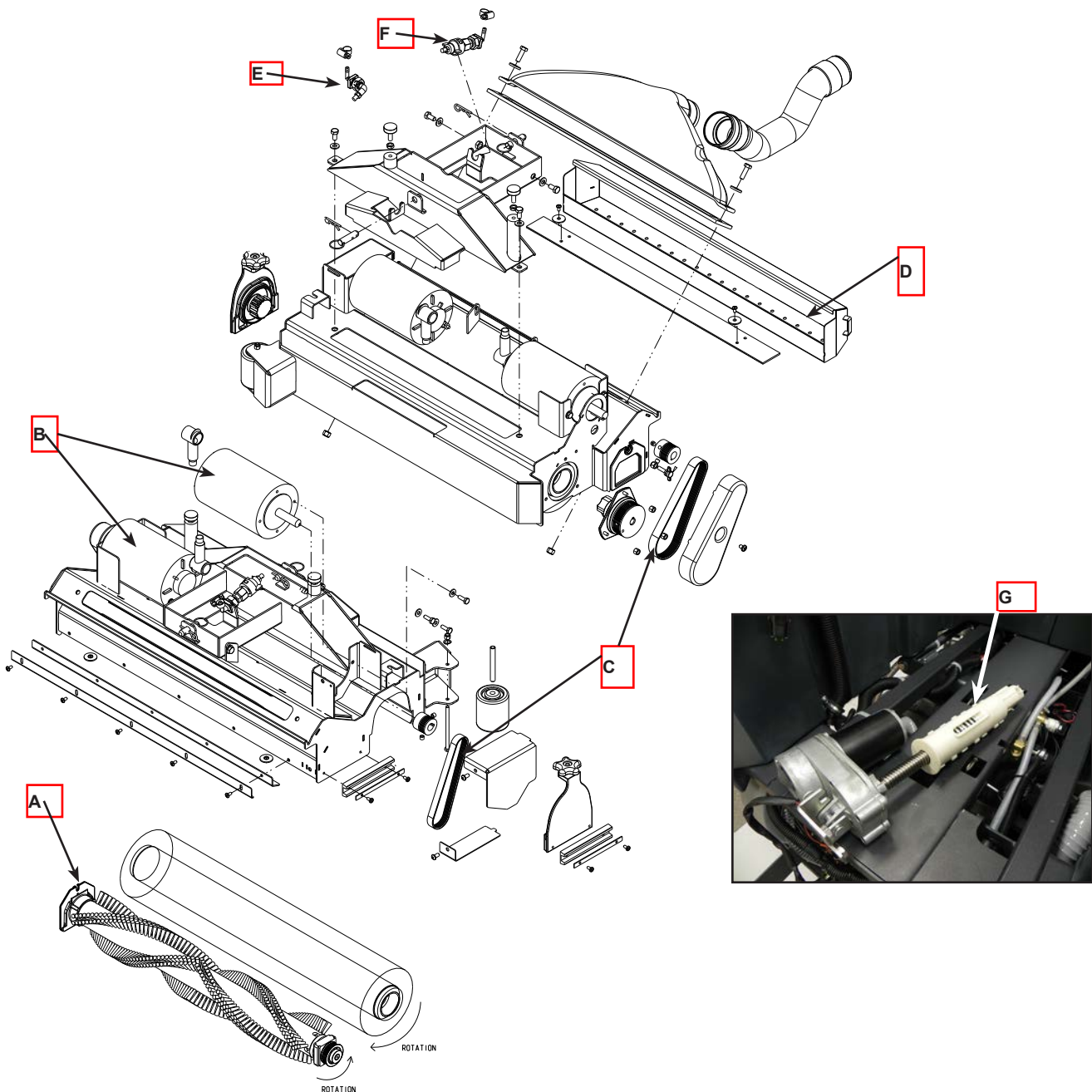

Figure D-1

## Maintenance and Adjustments

### Scrub System Brush Maintenance

The scrub system must be serviced at regular intervals to maintain good scrub performance. Follow the maintenance steps listed below.

1. Rinse clean, built up debris from the debris hopper drain holes (daily).
2. Remove any string wrapped around the scrub brush, drive hub and idler hub (daily).
3. Clean spray nozzles attached to the front and top of the scrub deck (weekly) (See Solution section of this manual).
4. Clean built up dirt from the inside of the scrub brush housing (weekly).
5. Remove both the scrub brushes and rotate, turn the front brush end for end (weekly). See Scrub Brush Removal and Installation section.
6. Inspect the scrub brush bristles for wear monthly. The brushes should be replaced when the bristle length of the front brush is 1 inch (26 mm) or less and when the bristle length of the rear brush is 3/4 of an inch (19 mm) or less.



## Troubleshooting

The ES4000 deck brush system's major electrical components are monitored by the main controller (A1) to detect any system function failures (error codes). The system components covered are the brush motor(s) (M7 & M8), brush solenoid (K1) and brush lift actuator motor (M1). Detected error codes from the main controller are displayed on the hour meter LED display **(E)** as they occur. See Functional Description section wiring diagram.

 *Note: Reference the Main Control Board Troubleshooting Guide in the Electrical System of this manual for specific fault descriptions and service repair actions.*

## Removal and Installation

### Scrub Deck Removal

1. See RECOVERY SYSTEM section of this manual to remove the vacuum hoses and shoes prior to deck removal. Also refer to Figures D1 & D1a through D-10.
2. To REMOVE the Scrub Deck assembly use the instructions on the following pages.
3. To INSTALL the Scrub Deck assembly follow the removal steps in reverse order.

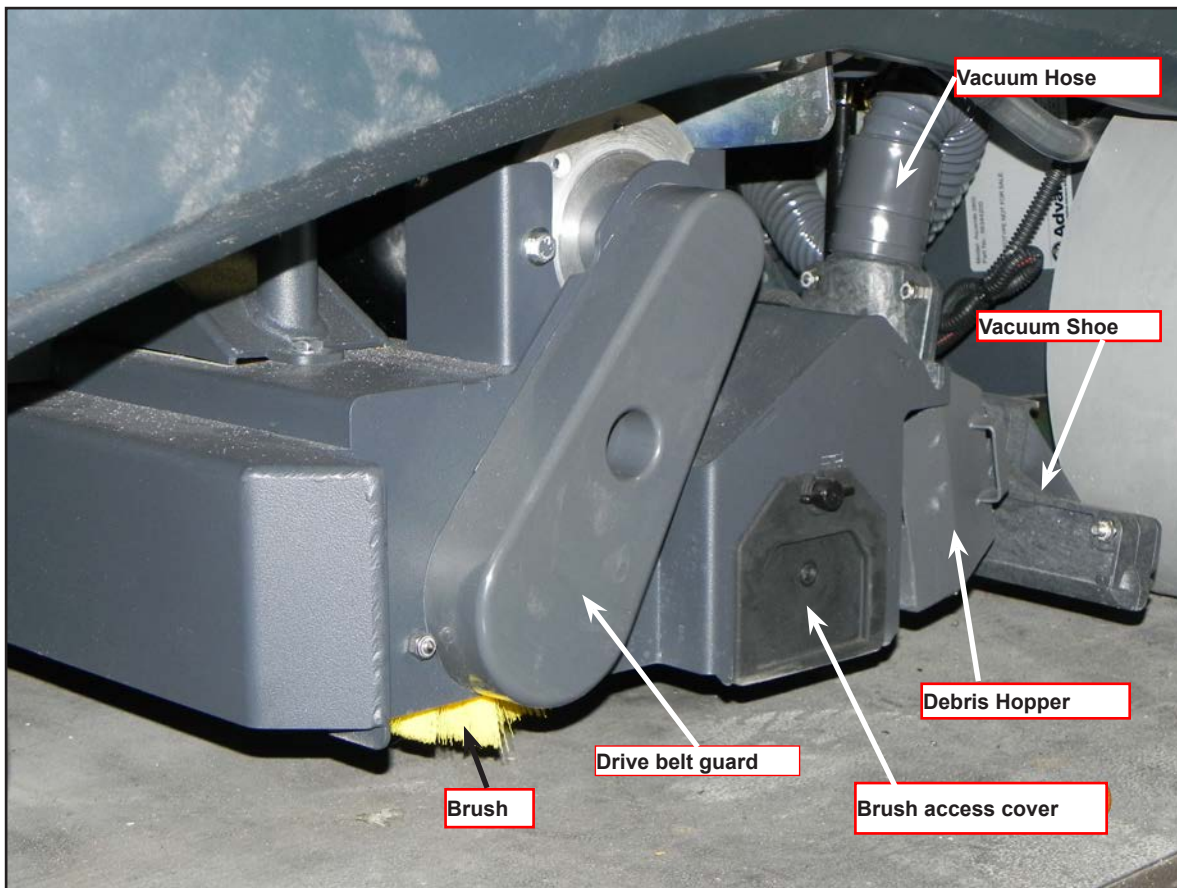

*Scrub Deck*

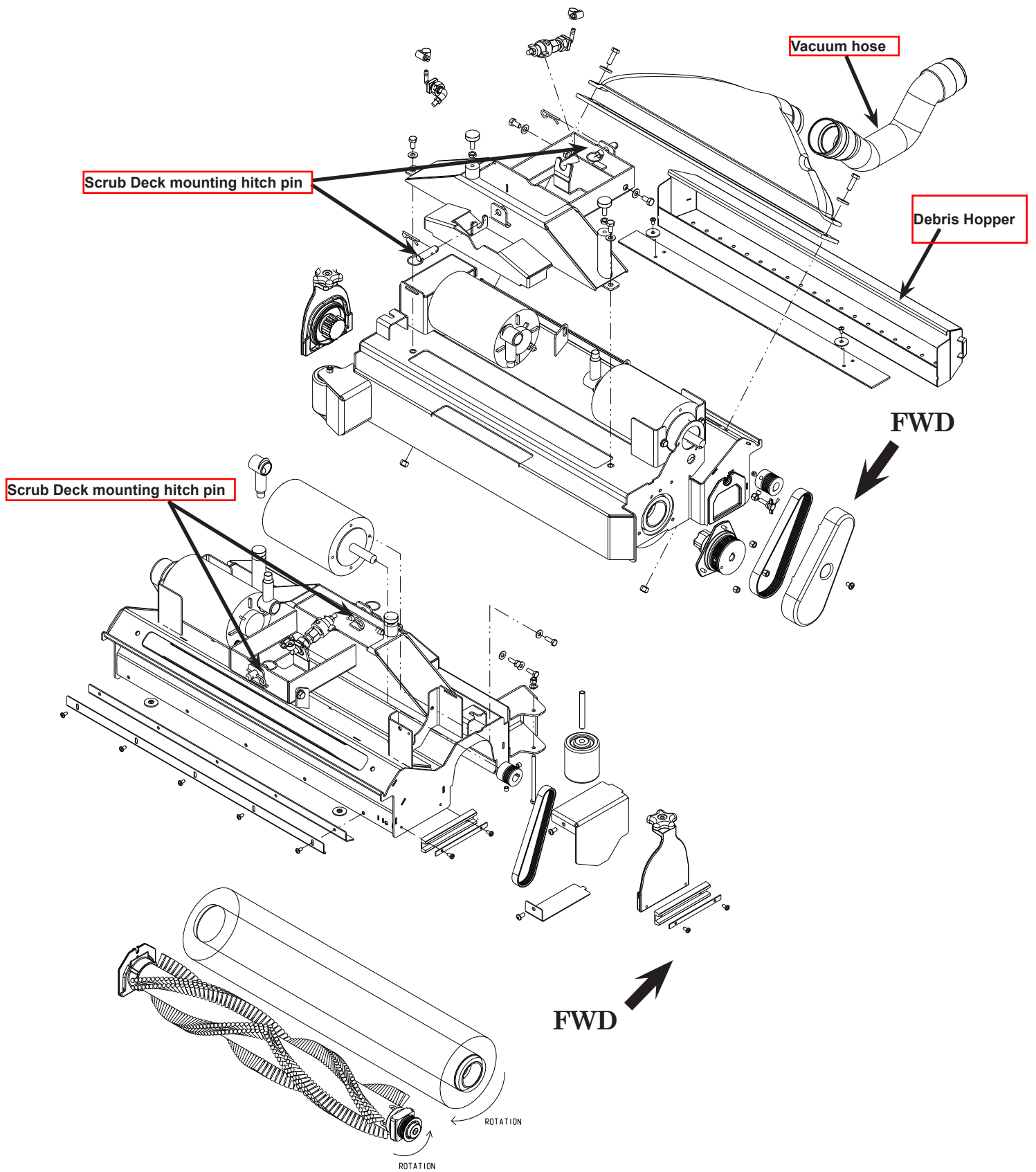
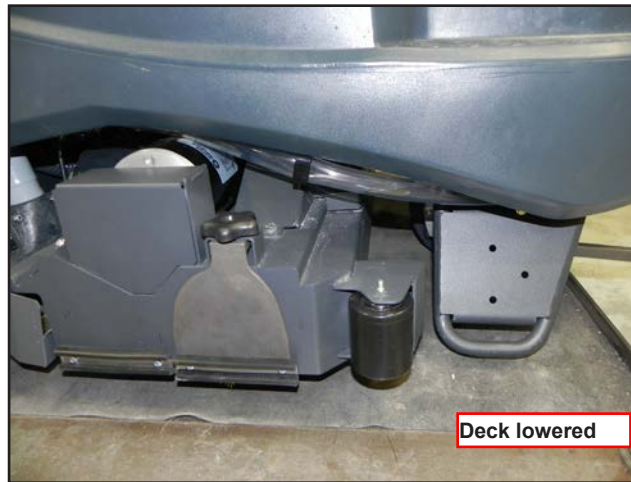

Figure D-1a

1. Lower the scrub deck with the brush(es) installed (Figure D-2).  
 Attention: Don't turn the key switch off until after disconnecting the battery pack with the Battery Disconnect (34). This will prevent the scrub deck from automatically raising when the key is turned off.

**Figure D-2**



2. Pull off the vacuum hose from the intake connector (Figure D1a). Remove both vacuum pickup shoes by lifting the removal chains then lift up and pull out to separate them from the shoe support weldment. (Figure D-3).

**Figure D-3**



3. Remove the sweep debris Hopper (Figure D4) from the scrub deck.

**Figure D-4**



4. Unplug the brush motor wiring harness (Figure D-5).

5. Remove the ground wire on the deck.



*Figure D-5*

6. Remove the Hitch Pin that secures the brush deck lift actuator to the scrub deck. (Figure D-6).



*Figure D-6*

7. Remove the tubing for the solution nozzles (Figure D-7).

Figure D-7



8. Remove the two Hitch Pins (Figure D1a & D-8) that attach the scrub deck to the machine chassis linkage arm weldment.

Figure D-8

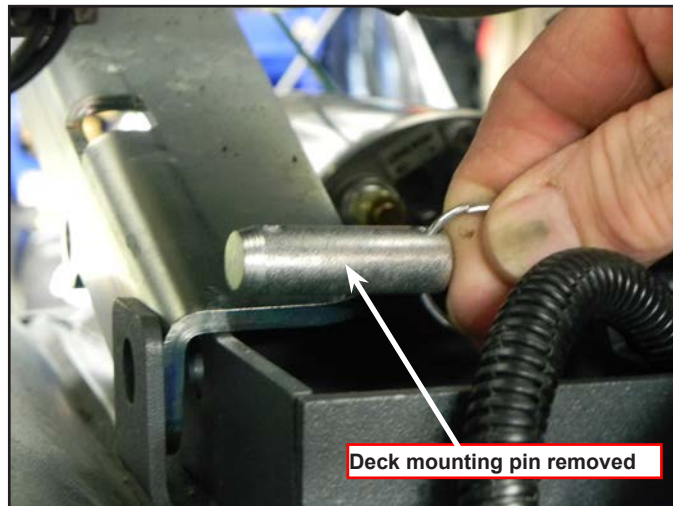

9. Carefully maneuver the deck from under the machine to complete its removal (Figure D-9).

**⚠ Service Note:** *It is important that the disconnected deck actuator motor is not run. This precaution will prevent the actuator drive nut from being moved from its set specification.*



Figure D-9

## Scrub Deck Actuator Removal

1. To remove the Scrub Deck Actuator begin by removing the Recovery Tank. This will expose the battery compartment and the lower accessory, Wet and Dry hose connections.

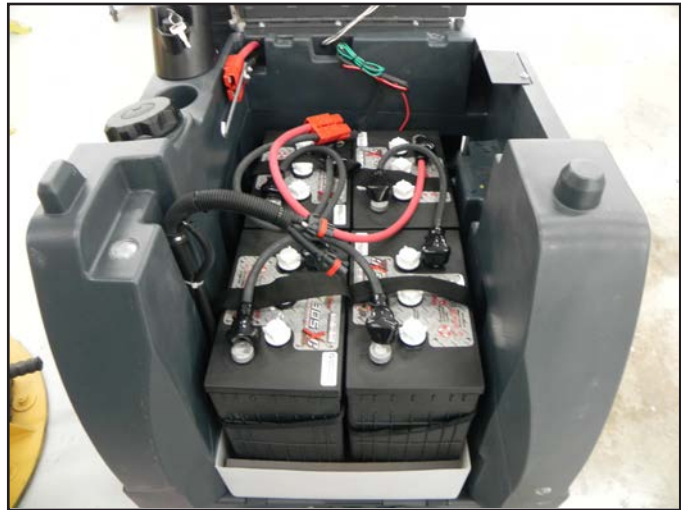

2. Remove the battery post connectors and disconnect the cable connectors at the rear of the compartment. Use a hoist to lift all of the batteries together or individually remove them from the battery tray.



3. Remove the battery tray. This will expose the access holes for the Actuators.

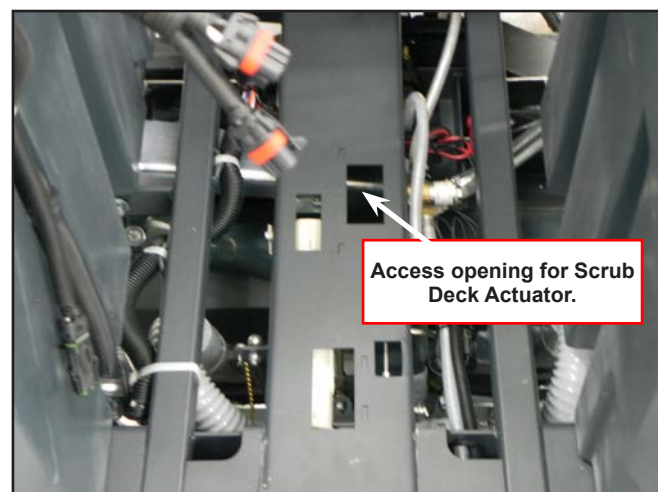

4 Working from the rear of the machine, locate the actuator position and the electrical harness for that particular actuator. Disconnect the harness to the actuator. The connection is usually near the end of the actuator (see circle in photo). Remove the 2 bracket screws over the Brush Lift Actuator motor.

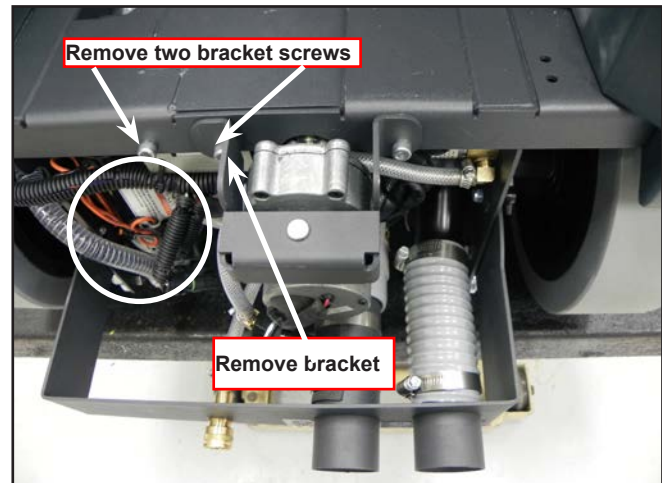

5. Place a wooden block under both sides of the deck. Tension will be released on the actuator allowing it to be loosened and the lift cable removed.



6. Attach the actuator power cord adaptor to the harness connector for the Deck Lift Actuator. Attach the Positive and Negative leads from the adaptor to a battery on the corresponding Positive and Negative terminals. See section on Actuator Drive Nut Adjustment.

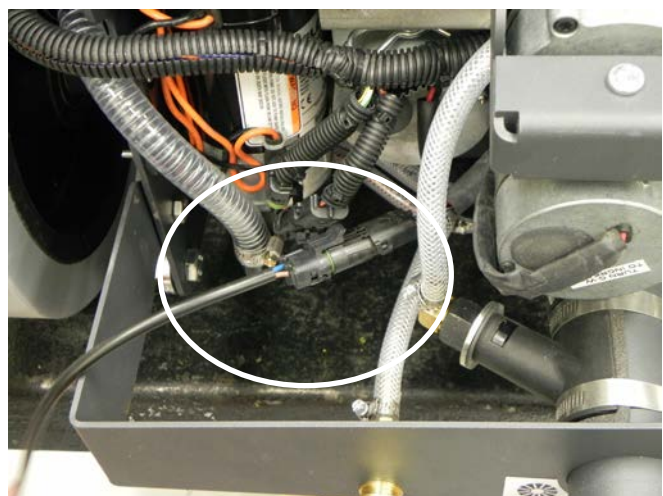

7. Make note of the actuator position in case it rotates out of adjustment.

Run the actuator with the power adaptor until the tension on the lift cable is released.



8. Remove the cotter keys at both ends of the mounting pin that passes through the end of the Actuator housing. Remove the washers and slide the brass bushings off the pin.



9. Remove mounting pin from the housing.



10. Remove the remaining fastener bolt in the frame. Be careful when the Actuator becomes loose. Be ready to grasp it with your hand.



11. Remove the Actuator Assembly from the frame.

12. To install the Actuator assembly after adjustments or replacement, reverse the removal process. Be careful to not spin the Spring Housing out of adjustment.



## Actuator Drive Nut Adjustment

The following instructions cover the procedure to adjust the drive nut (housing assembly) setting for the machine's scrub deck actuator motor. Reference the chart below that shows the IN & OUT dimensional specification for the actuator motor that is used on the ES4000.

| Actuator Motor   | Drive Nut Housing Assy<br>IN | • Drive Nut Housing Assy<br>OUT |
|------------------|------------------------------|---------------------------------|
| Brush Lift (ALL) | See Adjustment<br>Procedure  | 3.5 inches (89 mm)              |

The “Drive Nut Housing Assy IN/OUT Position” dimensions are measured when completely assembled and off the machine. Reference points are the edge of the plastic Spring Housing Assembly.

### General Instructions for All Actuator Motors

1. This shows the special actuator power cord adapter that is needed to connect a battery pack and actuator motor for setting the drive nut limit settings.
2. If the batteries are installed, open the machine battery compartment and disconnect the battery connector. The battery pack is needed to power the lift actuator motor to properly set the IN & OUT limit switches.
3. Connect the actuator motor to be tested to the power cord adapter end. Then connect the alligator clips from the cord adapter (red clip to the positive and black to negative) to battery connector or battery posts. The rocker switch is used to change the motor rotation in setting the correct drive nut dimension.

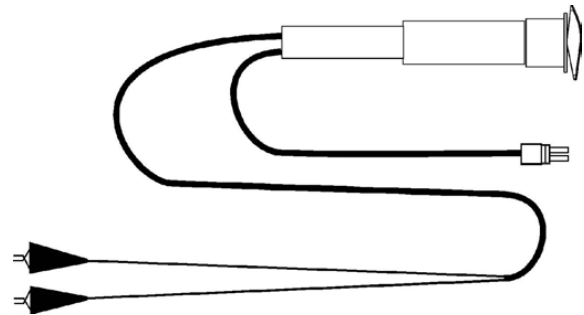

## Scrub Deck Lift Actuator Drive Nut Adjustment

1. Assemble spring housing
  - a. Install the 3 springs and drive nut into one half of the spring housing as shown. Then snap the two spring housing halves together, retaining the springs and nuts inside the housing.

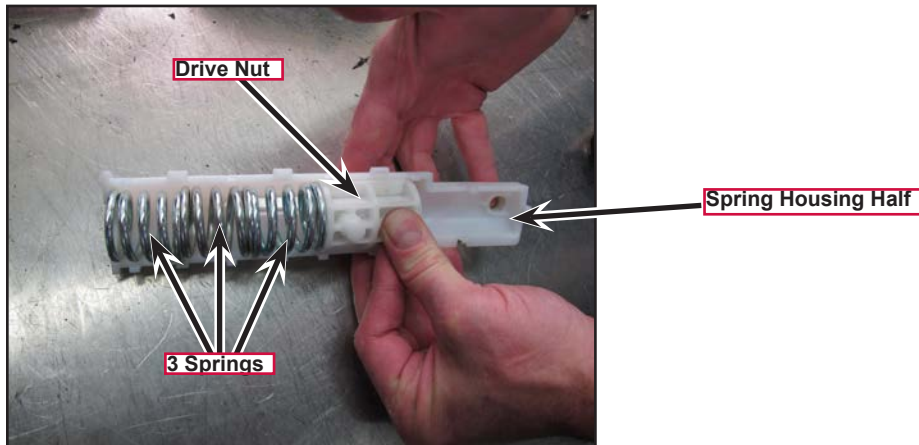

2. Screw the spring housing assembly onto the threaded drive screw a few turns.
3. Press the rocker switch on the power cord to run the drive motor all the way in until the motor stops.
4. Screw the spring housing onto the threaded drive screw until the end of the drive screw shaft just contacts the end of the spring housing.
5. Rotate the housing, either direction (whichever is shortest) until the “flat” surface of the housing will be “up” when the actuator assembly is installed on the machine.

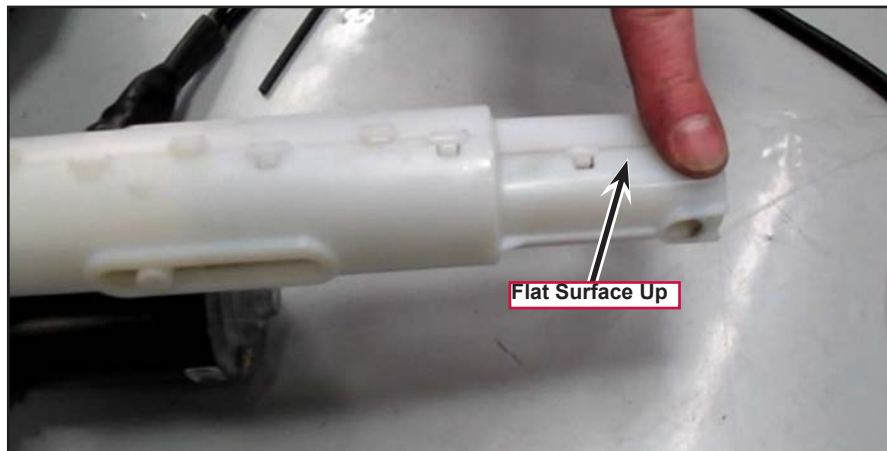

6. Hold the spring housing assembly then press the adapter cord rocker switch to run the drive motor to the OUT position (wait until the motor stops).

7. Measure the distance between the end of the spring housing and the motor housing. It should be 3.5 inches (89 mm)

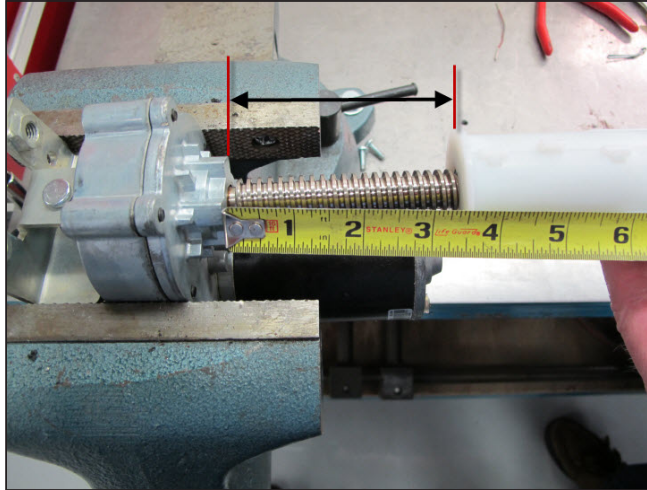

- a. If the distance is not correct, remove the rubber adjuster cover from the end of the motor. Then rotate the nylon nut found under the cover with a 1/2" (13 mm) SOCKET (Not a screwdriver!). Turning the nut one click will change the distance approximately on tenth of an inch (2.5 mm). After changing the adjustment, run the motor in and out and recheck the "Out" position distance.

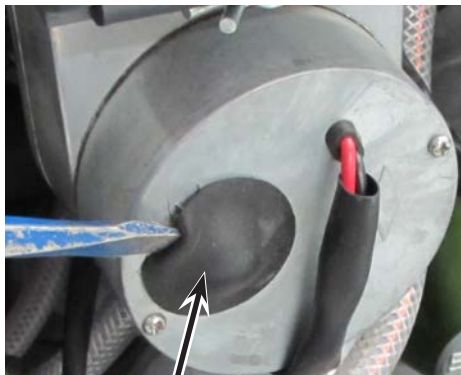

Remove Adjuster Cover

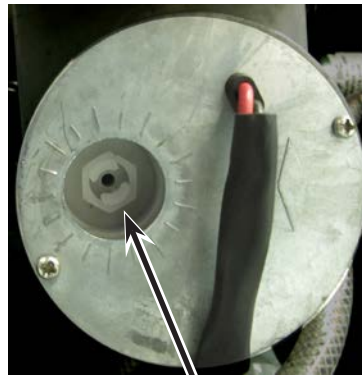

Rotate Nylon Nut to Adjust

 *Note: Use a 1/2" (13mm) socket to turn the adjuster.*

8. After each adjustment, hold the spring housing assembly, run the actuator IN & OUT and recheck the adjustments. Reinstall the adjuster cover.

## Brush Motor Removal

It is recommended that you remove the Deck assembly from the machine to remove the brush motors.

See Figures D-12 through D-15. Remove the Belt Guards (1 screw per side). With an operator in the driver's seat with the key switch ON and the maintenance mode scrub function selected press the drive pedal to start the scrub brushes and observe which brush motor needs to be removed.

**⚠ WARNING! Disconnect the battery pack by activating the emergency stop switch and using the battery disconnect before servicing.**

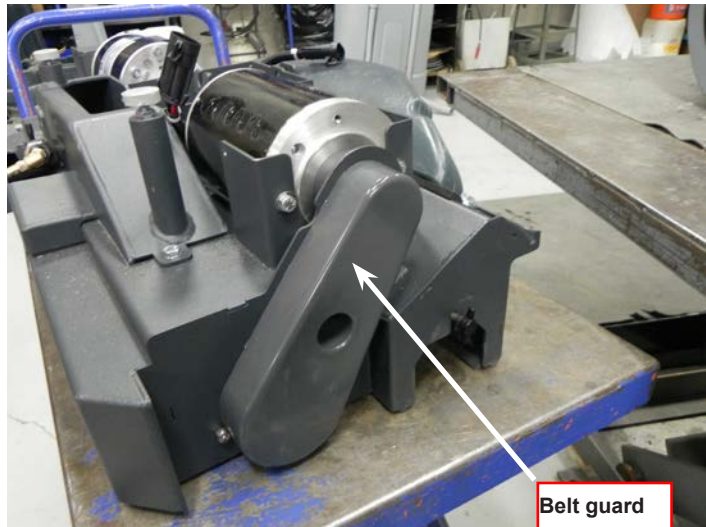

Figure D-12

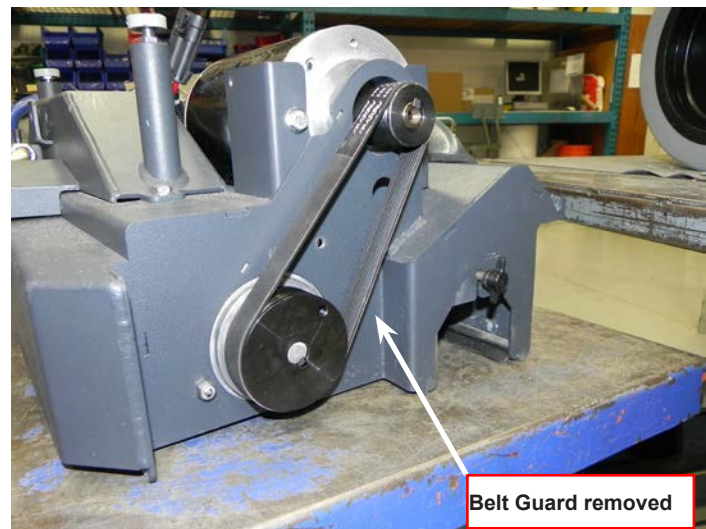

Figure D-13

Remove the scrub brush drive belt using a belt installation/removal tool (Figure D-14).

**⚠ Note: The installation/removal tool shown may be replaced by a flat blade screwdriver. The photo shows installation of the belt but removal uses a similar method.**

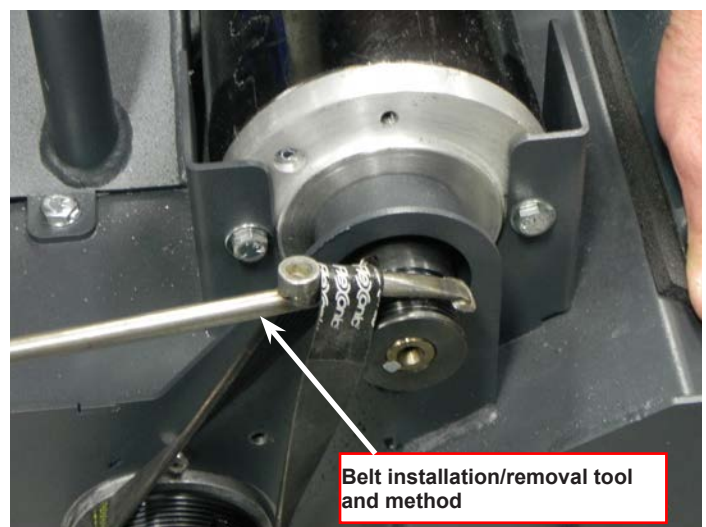

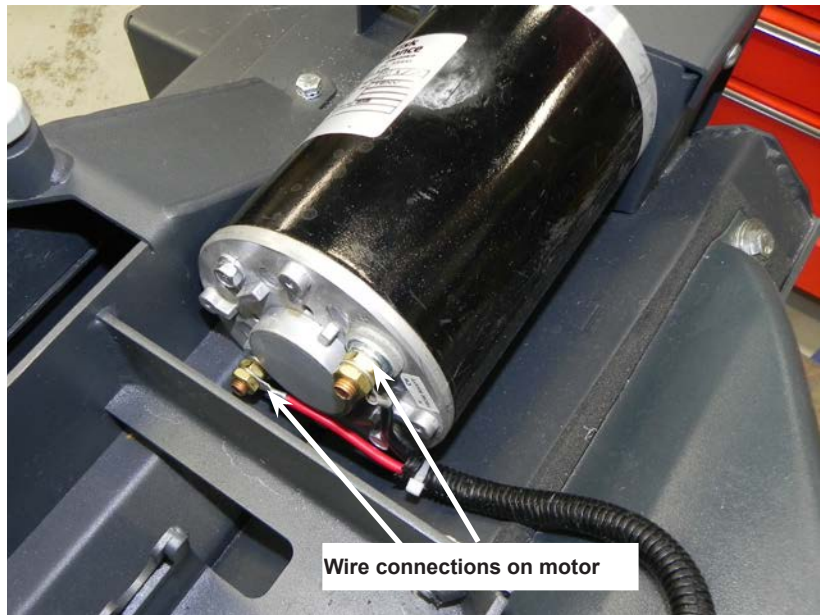

Figure D-14

Remove the wiring at both the Pos. & Neg. brush motor terminal studs and note the correct wiring connections (for reinstallation) (Figure D-15). Then remove the (3) Screws (Y) and lift the motor out from the scrub deck.

Reassemble in reverse order.

 *Note: Install motors with wires pointing to the rear towards the plastic motor wiring standoffs.*



**Figure D-15**

## Scrub Brush Belt Replacement

**⚠ WARNING!** Disconnect the battery pack by activating the emergency stop switch/battery disconnect lever (13) before servicing.

Remove the belt guard(s) (1 screw each).

**⚠ Important Service Tip:** The left and right side drive belts are not the same lengths and they must be ordered individually.



Remove the belt using a belt removal tool as shown in the photo. Re-install the drive belt. Re-install the belt guard, reconnect the battery pack and test the scrub system for proper operation.

**⚠ Note:** Rotation of shaft from shaft end is Counter-Clockwise (CCW) for both motors.

**⚠ Note:** The installation/removal tool shown in the accompanying photo can be replaced with a standard flat blade screwdriver.



### Scrub Brush Removal and Installation

Make sure the key switch is off and disconnect the battery pack before servicing.

See Figure D-16. Loosen the black fastener knobs (one on each side) that secure the removable access covers. Pull the covers down and out to remove. Grip the scrub brush and slide it out from the housing end.

To install the brush slide it into the housing, lift slightly, push and turn until it seats into the drive end assembly slots.

Re-install the access cover and tighten the fastener knobs.

See Figure D-17 for shaft rotation and orientation.

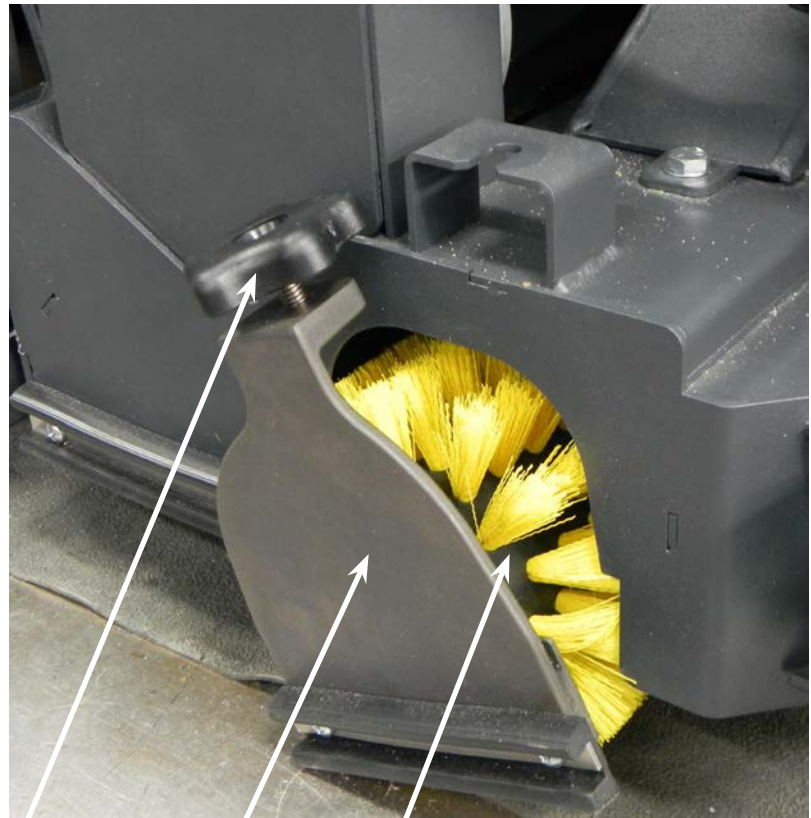

Figure D-16

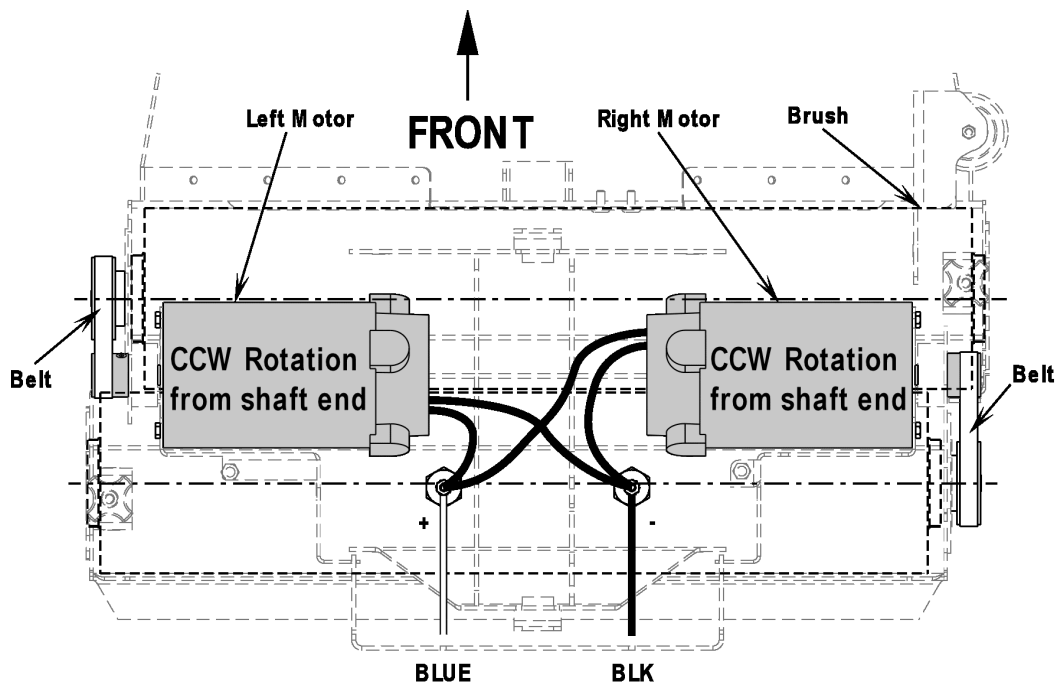

Figure D-17

## Specifications

### Scrub System

|                                    |   |                           |                      |
|------------------------------------|---|---------------------------|----------------------|
| Cleaning Deck Type(s)              | Cylindrical   |                           |                      |
|                                    |   |                           |                      |
| Cleaning Brush Size(s) and Type(s) | (2) 27 in (68.6 cm) Type: Cyl<br>Scrub path: 28 in. (71.1 cm) |                           |                      |
|                                    |   |                           |                      |
| Scrub Motor(s)                     | Right-hand Motor:   | .5 HP                     | 373 watts/15.54 Amps |
|                                    | Left-hand Motor:  | .5 HP                     | 373 watts/15.54 Amps |
|                                    |   |                           |                      |
| Scrub Head Speed(s)                | Right-hand Motor: 1800 RPM                                    | Left-hand Motor: 1800 RPM |                      |

## Special Tools

### Actuator Power Cord Adaptor—Part # 56407502

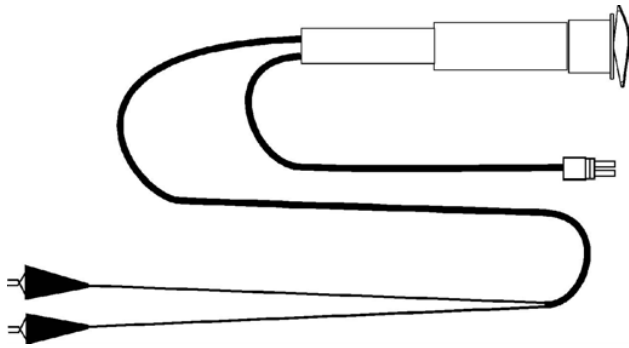

# Steering System

## Functional Description

The Steering System is all mechanical consisting of the steering wheel, shaft, gears and the chain gear drive on the Drive Wheel.

## Component Locations

The Steering System main components are:

- Steering Wheel
- Lower Column Shroud
- Lower Steering Column
- Steering Column Spindle
- Steering boot
- Steering knuckle
- Steering shaft, gears, chain gear on Drive Wheel

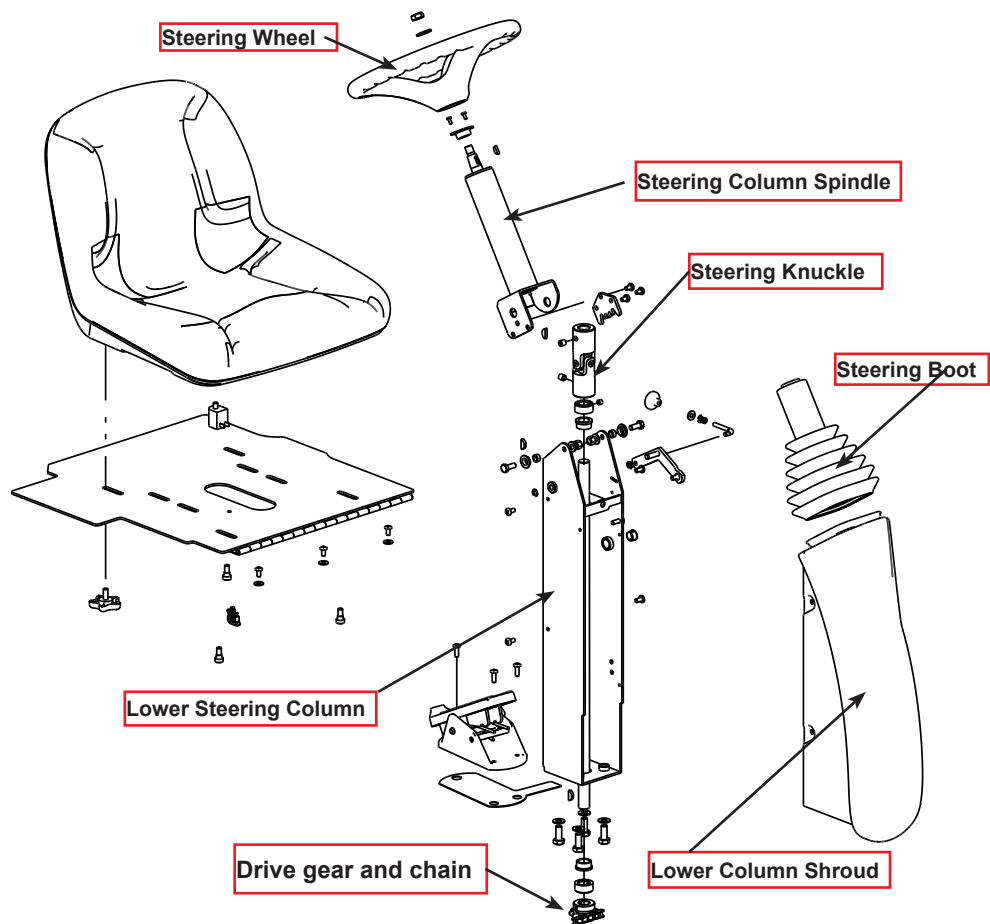

## Maintenance and Adjustments

The Steering System requires minimal maintenance and no adjustment. The most important maintenance item is the Steering Knuckle (Steering Wheel Shaft Universal Joint) where the Spindle attaches to the Column. This is a critical part of the steering mechanism and requires lubrication at least once per month. An oil fitting is located where the knuckle pivots. Use light machine oil in this fitting.

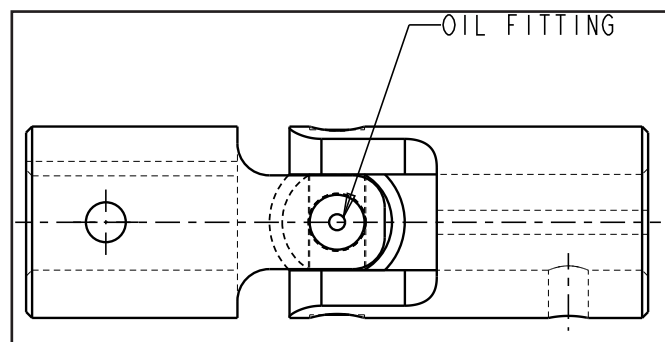
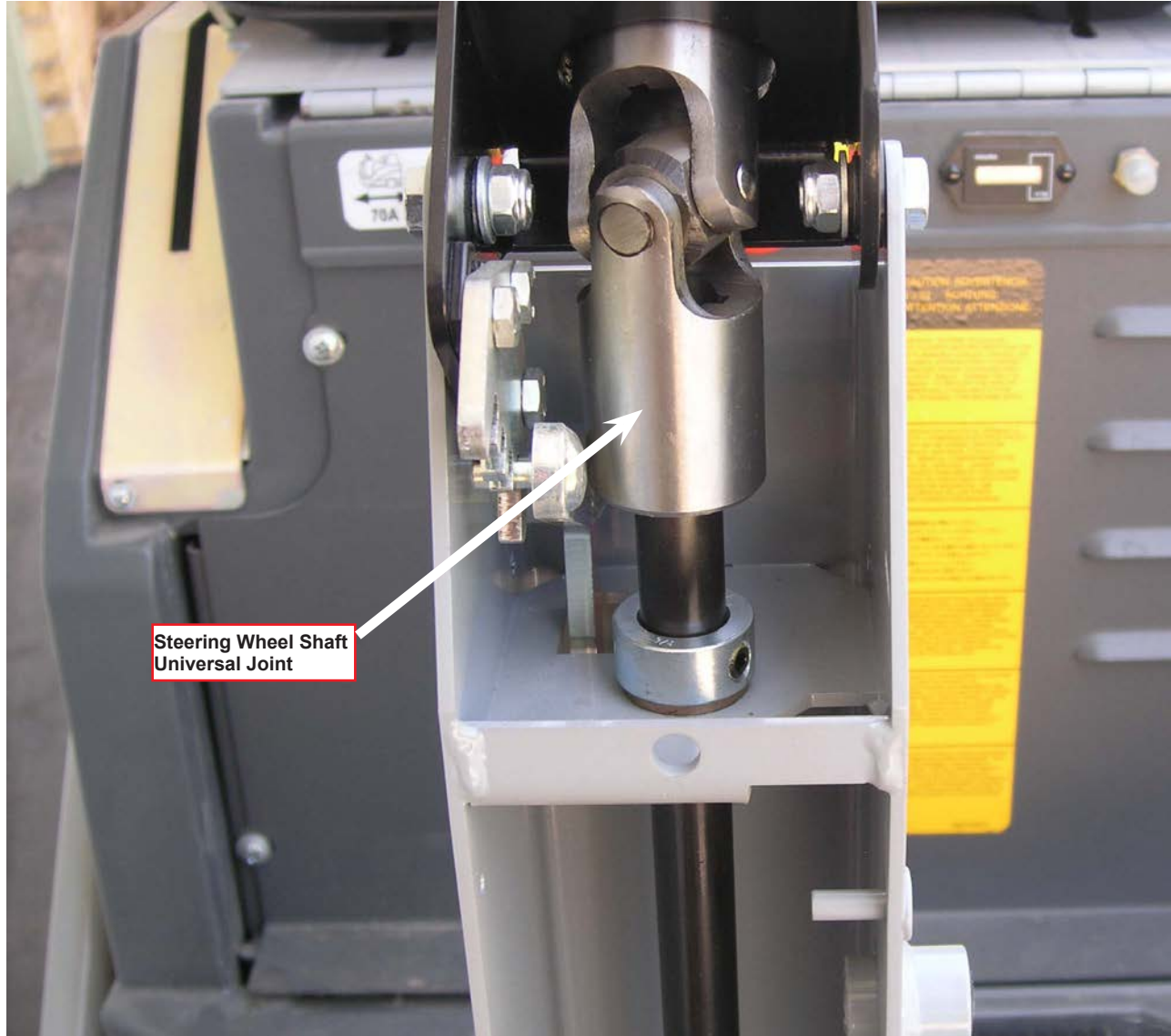

## Removal and Installation

### Steering Column shroud removal

1. Remove the 4 screws fastening the Lower Column Shroud to the Lower Column Weldment. Figure ST-1.

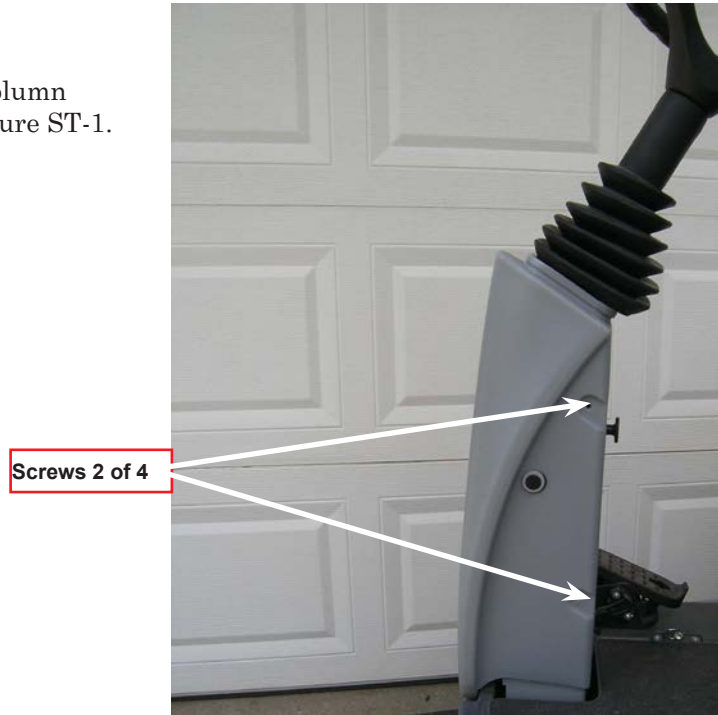

**Figure ST-1**

2. Using a flat bladed screwdriver, pry off the steering wheel plastic center cap.
3. Using a 3/4" socket, remove the hex nut from the steering wheel center.
4. Pound the steering wheel off from behind using a mallet, observing the Woodruff key as it may fall out the process.



**Steering Wheel removed**

in

5. Pull accordion Steering Boot from the upper steering column.



**Steering Boot**

6. Lift the battery charger cover.

**Shroud lifted from battery charger compartment**

**Battery charger cover open**



7. Pry the plastic Lower Column Shroud off the weldment by starting on the left side (away from knob) so shroud can clear the weldment linkage bump on the right side.

**Shroud lifted up and off the Steering Column**



Reassemble in reverse order, applying a light coat of Silicone spray or water to the inside of the Steering Boot. This will permit free travel over the shaft and ease assembly.

## Wheel System, Non-Traction

### Functional Description

The rear wheels are undriven and individually fastened to the machine via spindles and mounting bolts.

### Component Locations

The Wheel System Non-Traction consists of the two rear (Left and Right) wheels, tires, mounting washers and bolts and a wheel bearing. They are mounted to the rear spindles on the lower frame of the main chassis.

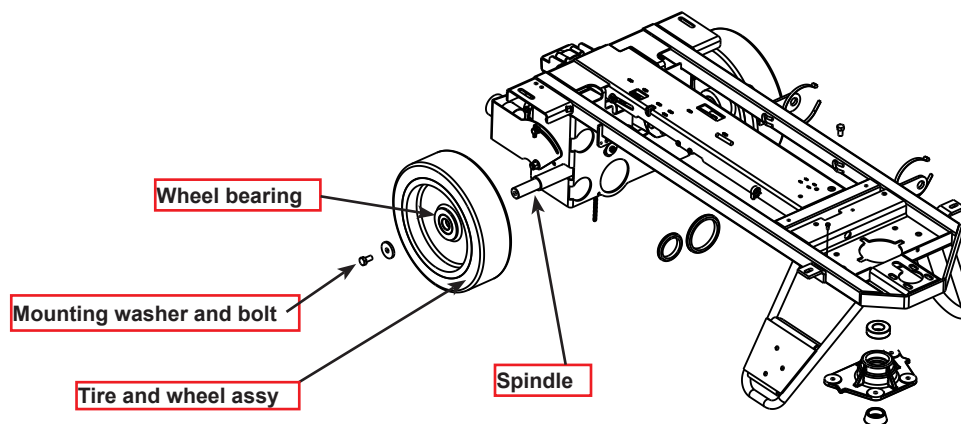

## Removal and Installation

### Replacing the Rear Wheels

1. Block the front Drive Wheel
2. Raise the Rear Wheel (17) to be replaced using a bottle jack on a secure frame member of the machine.
3. To prevent injury, if the rear wheel bearing has frozen, replace the bottle jack with blocks or a jack stand.
4. See Figure WNT-1. Use a 17 mm socket to remove bolt (A), washer (B) and wheel (C).
5. If the bearing has seized, pound off the wheel and use a bearing puller to remove the inner race from the axle.
6. Apply anti-sieze to the inner bearing surface of the new wheel. Install wheel on axle.
7. Apply anti-sieze to the bolt threads before tightening the bolt, washer and wheel.

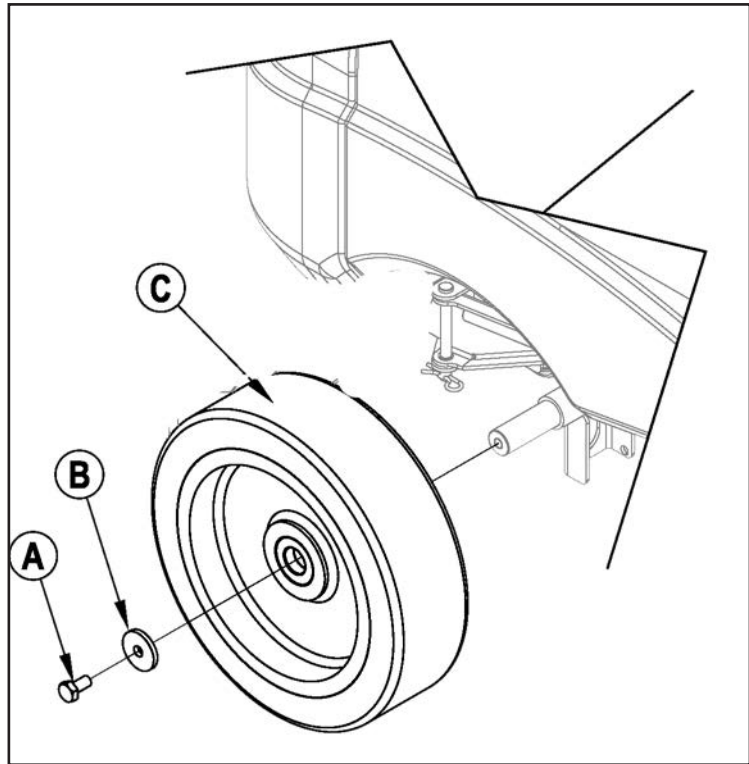

Figure WNT-1

## ***Wheel System, Traction***

---

### ***Functional Description***

The drive wheel assembly is directly connected to the speed controller, which not only provides an output signal of 24V to the drive wheel for forward and reverse movement, but also monitors current and temperature, and controls the electromagnetic brake. The speed controller is programmable through, and can be monitored via, the Curtis Handheld Programmer(part # 56409441) and Curtis Adapter Cable with Quad Plug (part # 56409823), listed in the Special Tools section of this chapter. For information on how to use the Curtis programmer, please refer to the Curtis Programmer Manual (doc. # 56043101).

The throttle potentiometer in the foot pedal controls drive speed and forward/reverse movement. The throttle pot input to the main control board also determines whether or not the vacuum system will engage and is therefore critical to machine performance. When the vacuum system is enabled, the brushes are energized and cleaning begins. If the control board senses a Neutral position of the foot pedal, it will not engage these systems unless placed in Service Test Mode or one of the vacuuming modes.

The Electromagnetic Brake is engaged whenever the foot pedal is in Neutral. When the Brake is released, Forward/Reverse is enabled and the drive wheel is energized.

### Wheel System, Traction Circuit Description

The A2 speed controller has heavy current battery positive and battery negative wires that supply the current it needs to drive the wheel motor. The controller wakes up when it receives power through the key switch, emergency stop switch and the seat switch.

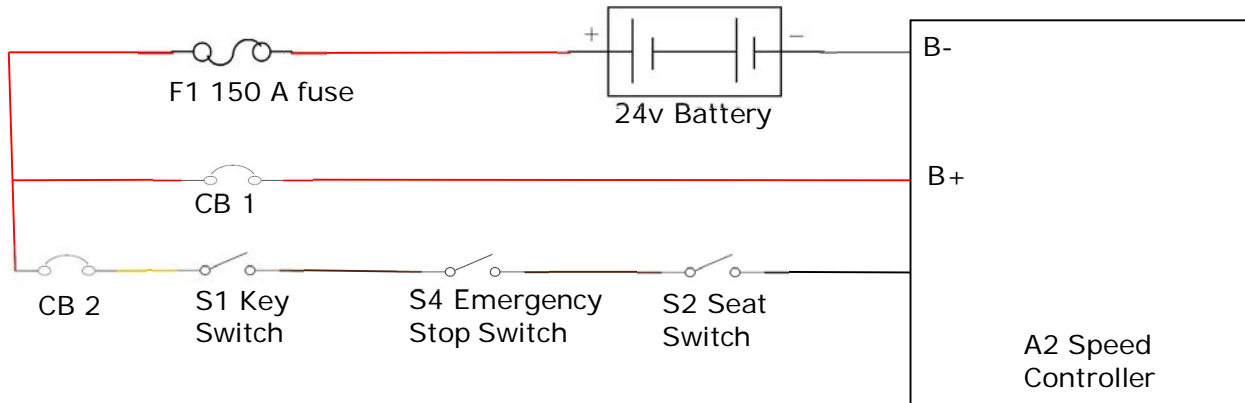

The controller switches power on to the drive wheel motor by providing a connection to battery positive on one wire and to battery negative on the other wire. To reverse direction the controller reverses polarity. Of course this is a slightly simplified explanation, as the motor is not merely switched full on or off. The controller regulates the amount of voltage supplied to the motor to control the motor speed.

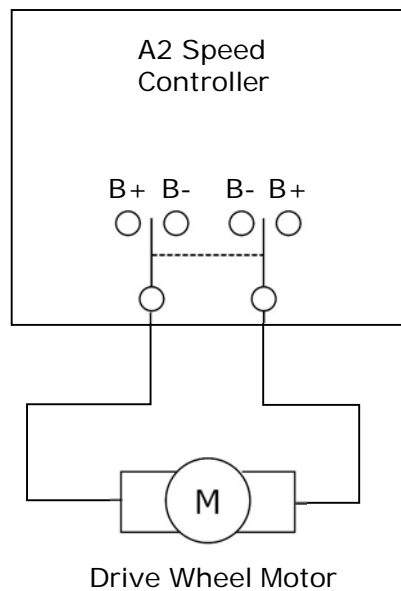

The main input for the speed controller is the drive pedal potentiometer. The controller sends out a regulated five volt supply to one side of the potentiometer. The other side of the potentiometer is connected to battery negative through the POT Low circuit inside the speed controller. This provides a clean filtered ground. A third wire runs from the speed controller to the center terminal of the potentiometer. This is called the “signal” or “wiper” circuit. Inside the potentiometer, a “wiper” moves along a resistive strip. When the drive pedal is in the center or “neutral position”, the wiper is exactly in the middle of the resistive strip and the voltage output is 2.5v to the speed controller. As the drive pedal is moved forward, the wiper moves toward the 5v supply so the voltage increases up to nearly 5v when the pedal is all the way forward. When the drive pedal is moved backwards from the center position the wiper moves towards the ground supply so the voltage drops from 2.5 V down to nearly 0v in full reverse. These voltage changes are “understood” by the controller and are used to request forward and reverse direction as well as speed.

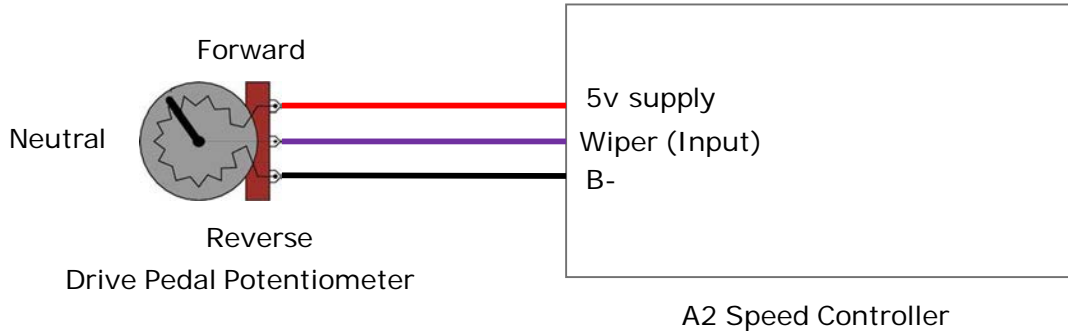

There is a second input, called “Speed Limit” that is used to regulate top speed. The POT high and POT low circuits are also provided to the A1 main controller from the A2 speed controller. This is a 5 V supply source which the main controller modifies and sends back on the speed limit circuit to the drive controller. To request a high top speed, the main controller sends a higher voltage. To request a lower top speed, the main controller reduces the voltage. The speed limit request is dependant on the machine operating mode.

The drive wheel has an electronic brake which is spring-loaded in the locked position. To release the brake, an electric solenoid must be energized. The speed controller supplies battery positive to one side of the brake solenoid winding and switches the other side to battery negative to release the brake. The brake is released whenever the drive pedal is moved from the center “neutral” position in either the forward or reverse direction.

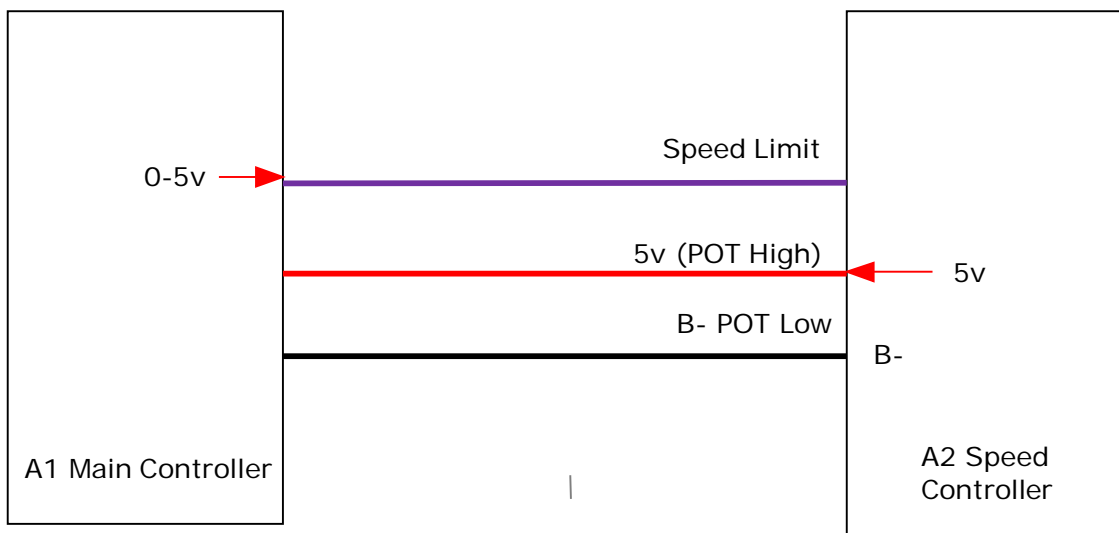

There are also three wires that run between the speed controller and the main controller to communicate speed controller functions to the main controller. The FWD/REV circuit is used to let the main machine controller know that the machine is moving in either direction. This allows the machine to turn the scrub motors off when the machine is sitting still and turn them back on when the machine begins to move. Here is how the circuit works. The main controller sends a 24 V power supply through an internal resistor to a switch inside the speed controller. There is an “internal voltmeter” inside the main controller that monitors the voltage between the resistor and the switch. When the switch is open the voltmeter sees 24 volts. When the switch is closed the voltmeter sees 0 volts. The speed controller closes the switch whenever it is driving the wheel in either the forward or the reverse direction. (This same switch is used to energize and release the brake).

The REV circuit works just like the forward/reverse circuit except that the speed controller only closes the switch when the machine is moving in the reverse direction. This means that in a neutral position and forward position the voltage seen on the reverse wire would be 24 volts. When the machine is moving in the reverse direction the voltage seen would be zero volts.

There is also a “status” circuit which is used to communicate whether or not there are any speed controller faults to the main controller. It is used to let the main controller know that a speed controller fault has been set (Error 03) and tell it which speed controller fault is set, so that the main controller can flash out the appropriate speed controller fault on the vacuum switch LED. It works similar to the other circuits where the main controller supplies 24 V through resistor to a switch inside the speed controller. As the switch opens and closes its cycles of voltage on an offer from 24 V to 0 V.

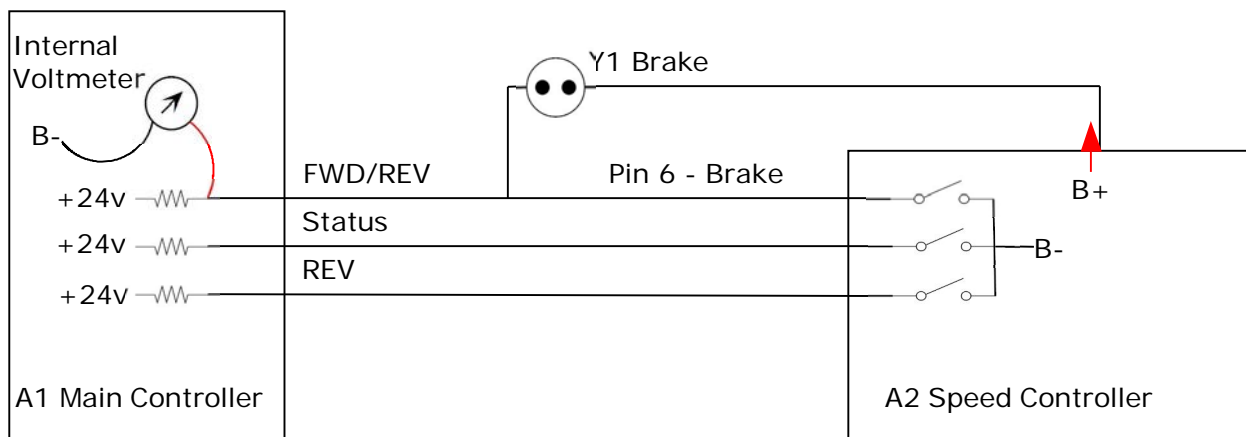

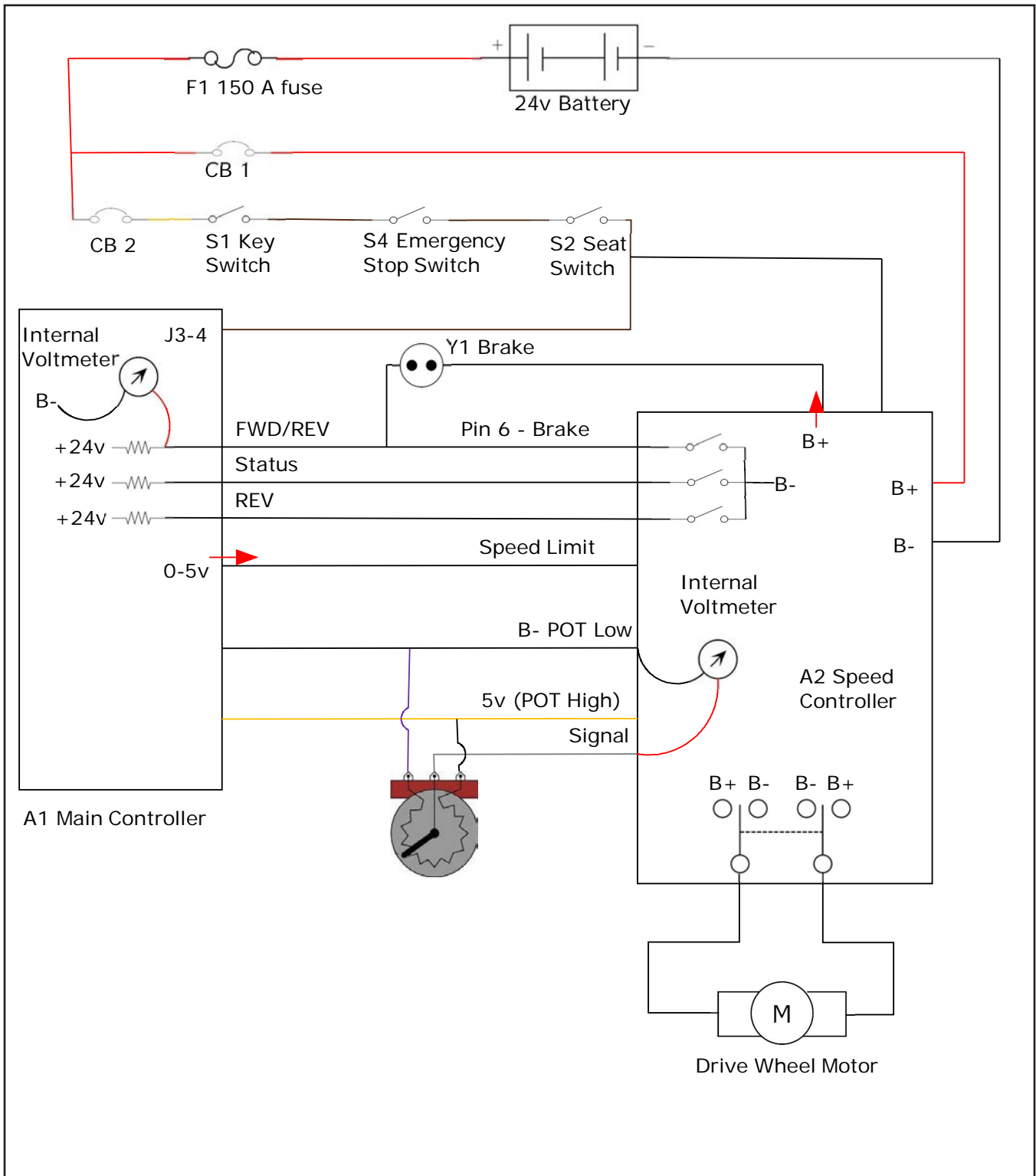

Speed Control System Functional Electrical Schematic

## Component Locations

- Lower Chassis
- Drive Spindle
- Drive Wheel assembly with Electromagnetic Brake
- Drive Pedal (forward/reverse) and Potentiometer (Also shown in CONTROL SYSTEM)
- Curtis Speed Controller

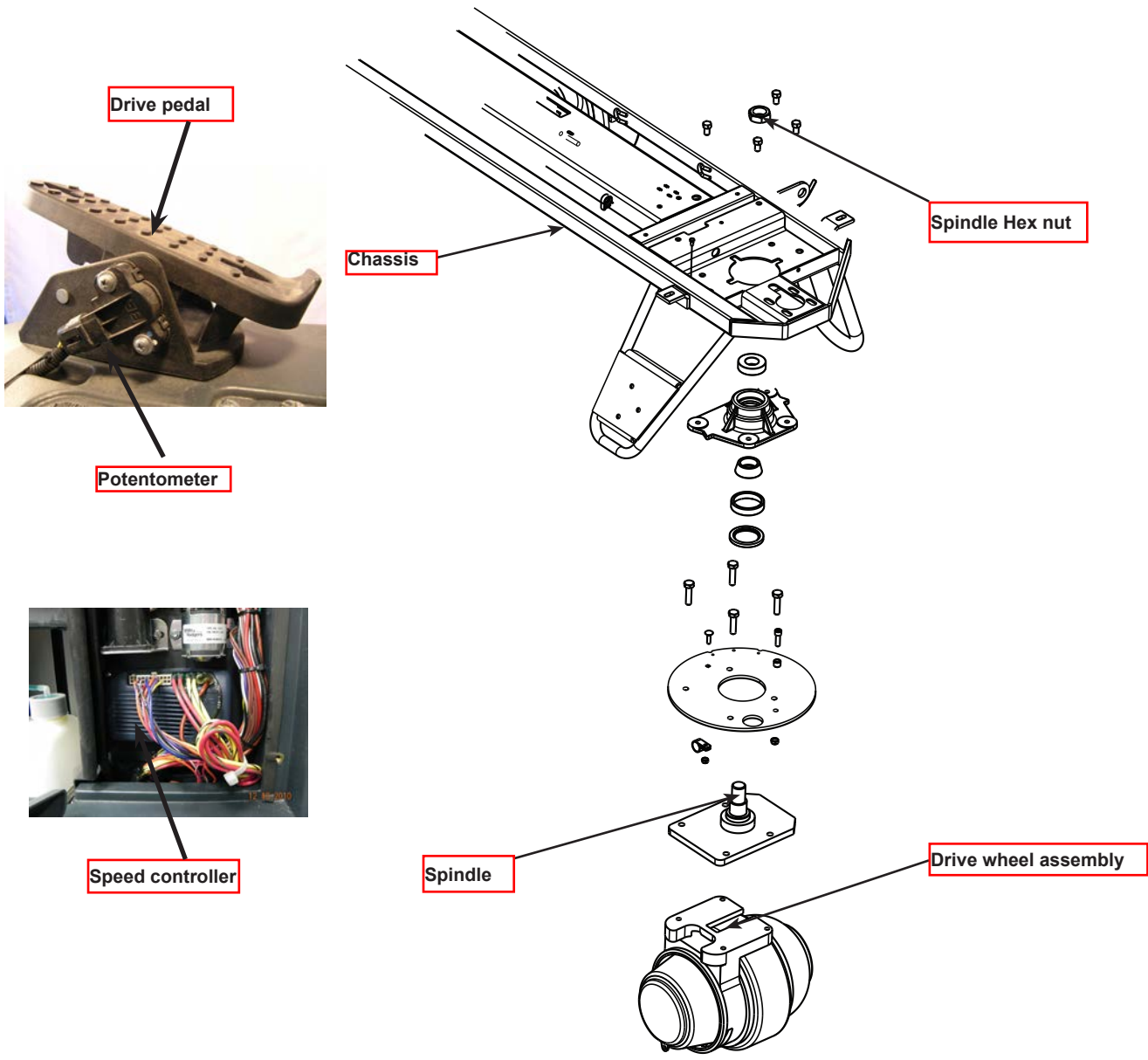

Wheel Drive System

## Maintenance and Adjustments

The Speed Controller is programmable. Programming is covered in the manufacturer's literature. When the Speed Controller is replaced (installed) a specific checkout procedure is required.

### Curtis Speed Controller Installation Checkout Procedure

After installing a controller and before operating the vehicle, carefully complete the following checkout procedure. If you find a problem during checkout, refer to the Curtis programmer manual for more information.

The installation checkout can be conducted with or without the handheld programmer. The checkout procedure is easier with a programmer otherwise observe the Status LED for codes (located on operator panel wand indicator light).

 **WARNING! Put the vehicle up on blocks to get the drive wheel off the ground before beginning these tests. Turn the key switch off and make sure that the seat switch is open, and the throttle (pedal) is in neutral. Do not stand, or allow anyone else to stand, directly in front of or behind the vehicle during the tests.**

Remove the electrical cover panel to access the controller.

1. Observe the error status fault indicator (DETERGENT LED) on the operator control panel. If a programmer is available, connect it to the programmer plug-in port
2. Sit on the seat and turn the key switch on. The programmer should “power up” with an initial display. If neither happens, check for continuity in the key switch circuit and controller ground.
3. If you are using a programmer, put it into diagnostic mode by pressing the DIAGNOSTICS key.
  - If there is no error detected, the display should indicate “No Faults Found”. Note: Before pressing the diagnostics key, wait until model # screen appears, if the throttle is activated prior to this screen appearing the controller will shut down.
  - If there is a problem, the control panel will flash a diagnostic code and the programmer will display a diagnostic message. If you are conducting the checkout without a programmer, refer to the Status LED Fault Codes table in “Speed controller Error Flash Codes” to diagnose the cause.
4. When the problem has been corrected, it may be necessary to cycle the key or seat switch to clear the fault code.
5. While sitting on the seat, operate the throttle. The motor should begin to turn in the selected direction. If it does not, verify the wiring to the controller, and the motor. The motor should run proportionally faster with increasing throttle. If not, refer to the Curtis manual.
6. Put the programmer into test mode by pressing the TEST key. Scroll down to observe the status of the forward, reverse and brake switch. Cycle each switch in turn, observing the programmer. Each input should show the correct state on the programmer.
7. Take the vehicle off the blocks and drive it in an open area. It should have smooth acceleration and good top speed.

## Troubleshooting

### General Troubleshooting

When troubleshooting various problems related to the WHEEL SYSTEM it is best to approach the issues with some fundamental steps:

1. If the machine isn't responding to the drive pedal inputs, forward or reverse, visually inspect that all connections are intact, such as the potentiometer connection.
2. Check and test the batteries for proper charge.
3. Check for any Fault codes. If codes are present, repair malfunction if possible.
4. Be sure the key switch is correctly inserted and/or reset the machine by turning the key off and then ON again.

If these basic checks do not reveal the nature of the problem then see simplified wiring diagram in electrical section of this manual.

| Problem  | Possible Cause   |
|--|--|
| Machine will still not move forward or reverse                         | <ol style="list-style-type: none"> <li>1. Wheel drive motor circuit breaker (CB1) tripped (reset 70A circuit breaker).</li> <li>2. Control board circuit breaker (CB2) tripped (reset circuit breaker).</li> <li>3. Emergency stop knob tripped (pull out and twist).</li> <li>4. Safety switch (S2) in seat not closed (check seat switch).</li> <li>5. Defective wheel drive motor (replace motor).</li> <li>6. Defective throttle potentiometer (replace).</li> </ol> |
| The wheel drive motor will run only in forward or run only in reverse. | <ol style="list-style-type: none"> <li>1. Test the Potentiometer wiring outputs pins 3, 4, &amp; 13) at the speed controller for an open. Repair wiring or replace the Drive Pedal Assembly.</li> <li>2. Controller can't change electrical polarity to wheel motor - replace the (A2) speed controller.</li> </ol>  |

| Pin | Function            | Wire Color |
|-----|---------------------|------------|
| 3   | 5.02k Ohm Pot High  | YEL        |
| 4   | 5.02k Ohm pot Wiper | GRA        |
| 5   | Seat switch         | GRA/BLK    |
| 6   | Brake - (minus)     | RED/WHT    |
| 8   | Mode                | BLK/WHT    |
| 9   | Error status        | ORN/BLU    |
| 13  | 5.02k Ohm Pot Low   | VIO        |
| 14  | Brake + (plus)      | ORN        |
| 16  | Reverse alarm       | BLU/BLK    |
| 18  | Speed limit         | BLK/WHT    |

#### A2 Pin assignments

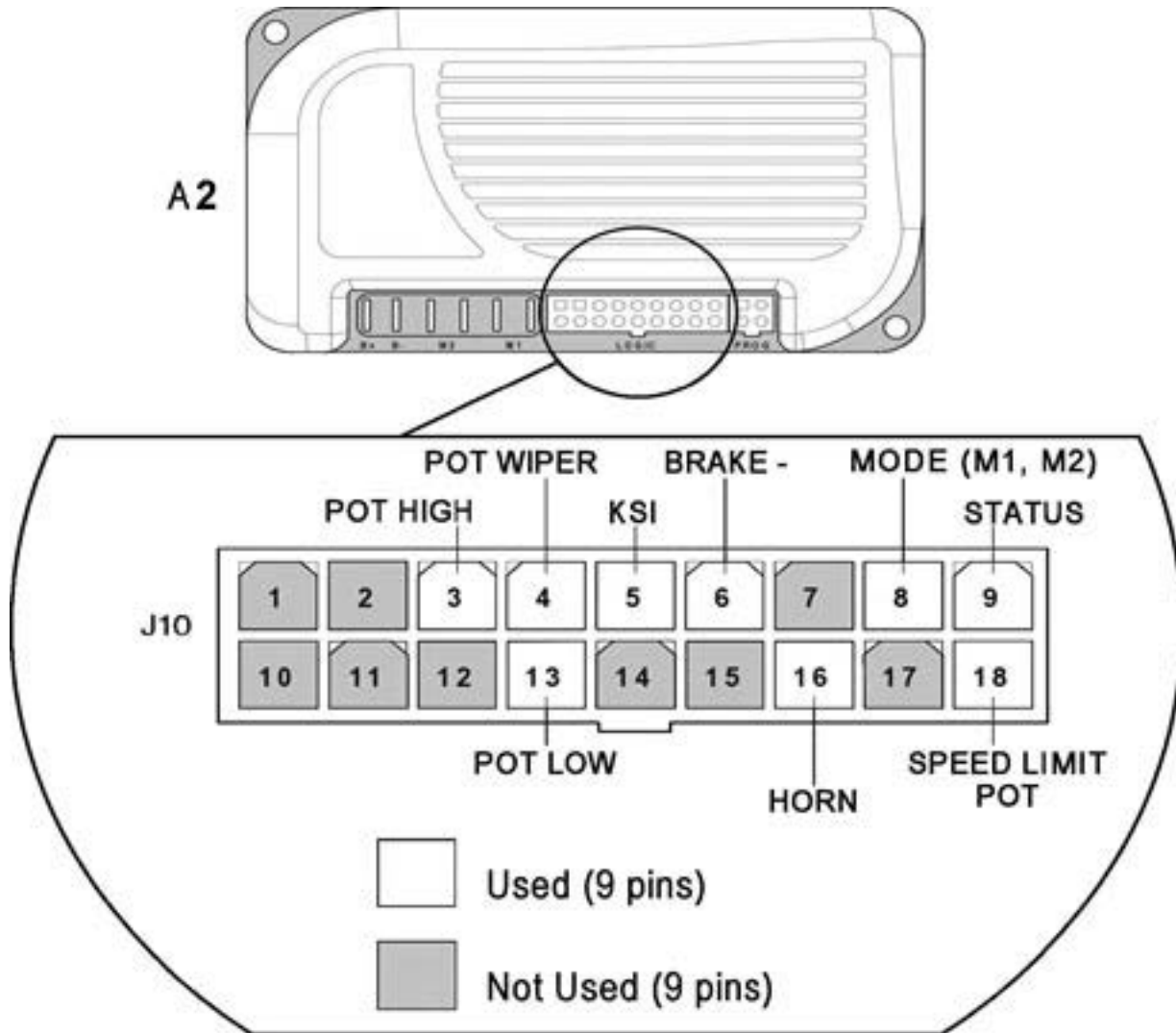

A2 (J10) pin outs

| Wheel Drive Motor | Typical Current (AMPS)<br>Transport, Full Throttle | Wire colors                |
|-------------------|--|----------------------------|
| M1                | 15-20  | Red/Green and Yellow/Black |

### Speed Controller Diagnostics

The Speed Controller diagnostics uses the machine’s control panel LCD display and DETERGENT switch indicator. Another available method is to use the optional hand held Curtis programmer model 1311.

### Speed Controller Status Light /Display Functions

If a speed controller fault occurs, the LCD display will indicate “E03”. Additionally the DETERGENT button LED flashes out a specific speed control error code until the fault is corrected. Speed control codes consist of two digits. Count the flash sequence of the DETERGENT LED to obtain the code. Example: (OOO O )3 flashes and a short pause followed by 1 flash and a long pause = 3,1 See ERROR CODES table for a description of the fault indications.



Speed Controller

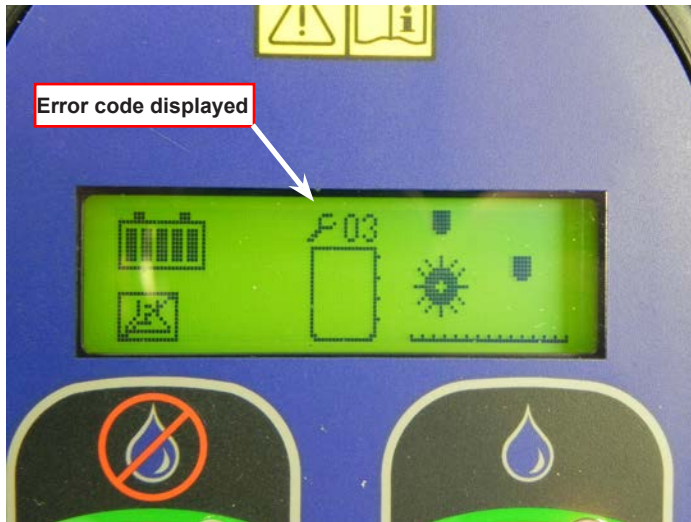

## Wheel Drive Circuit Error Codes / Speed controller Error Flash Codes

These codes are displayed on the main control panel display and flash codes on the DETERGENT LED.

| CODE | DETERGENT<br>BUTTON LED<br>DISPLAY | EXPLANATION  | POSSIBLE CAUSE   |
|------|------------------------------------|--|--|
| 1,1  | ○ ○                                | Speed controller fault-<br>over/under<br>- temperature cutback |  |
|      |                                    |  | 1. Temperature >97°C (206°F) or <<br>-25°C (-13°F).                  |
|      |                                    |  | 2. Excessive load on vehicle.  |
|      |                                    |  | 3. Operation in extreme environments.                                |
|      |                                    |  | 4. Electromagnetic, foot or parking<br>brake not releasing properly. |
| 1,2  | ○ ○○                               | throttle fault   | 1. Throttle input wire open or shorted.                              |
|      |                                    |  | 2. Throttle pot defective.   |
|      |                                    |  | 3. Wrong throttle type selected.                                     |
| 1,3  | ○ ○○○                              | speed limit pot fault  | 1. Speed limit pot wire(s) broken or<br>shorted.                     |
|      |                                    |  | 2. Broken speed limit pot.   |
| 1,4  | ○ ○○○○                             | battery voltage too low  | 1. Battery voltage <17 volts.  |
|      |                                    |  | 2. Bad connection at battery or<br>controller.                       |
| 1,5  | ○ ○○○○○                            | battery voltage too high                                       | 1. Battery voltage >36 volts.  |
|      |                                    |  | 2. Vehicle operating with charger<br>attached.                       |
|      |                                    |  | 3. Intermittent battery connection.                                  |
| 2,1  | ○○ ○                               | main contactor driver Off<br>fault                             | 1. Main contactor driver failed open.                                |
| 2,3  | ○○ ○○○                             | main contactor fault   | 1. Main contactor welded or stuck open.                              |
|      |                                    |  | 2. Main contactor driver fault.                                      |
|      |                                    |  | 3. Brake coil resistance too high.                                   |
| 2,4  | ○○ ○○○○                            | main contactor driver On<br>fault                              | 1. Main contactor driver failed closed.                              |
| 3,1  | ○○○ ○                              | HPD fault present for<br>>10 sec.                              | 1. Misadjusted throttle.   |
|      |                                    |  | 2. Broken throttle pot or throttle<br>mechanism.                     |

| CODE | DETERGENT<br>BUTTON LED<br>DISPLAY | EXPLANATION                             | POSSIBLE CAUSE  |
|------|------------------------------------|---|---|
| 3,2  | 000 00                             | brake On fault                          | 1. Electromagnetic brake driver shorted.<br>2. Electromagnetic brake coil open.   |
| 3,3  | 000 000                            | precharge fault                         | 1. Low battery voltage.<br>2. KS1 and Throttle turned ON at the same time   |
| 3,4  | 000 0000                           | brake Off fault                         | 1. Electromagnetic brake driver open.<br>2. Electromagnetic brake coil shorted.   |
| 3,5  | 000 00000                          | HPD (High Pedal Disable) fault          | 1. Improper sequence of throttle and KSI*, push, or inhibit inputs<br>2. Misadjusted throttle pot                           |
| 4,1  | 0000 0                             | current sense fault                     | 1. Short in motor or in motor wiring.<br>2. Controller failure.   |
| 4,2  | 0000 00                            | motor voltage fault (hardware failsafe) | 1. Motor voltage does not correspond to throttle request.<br>2. Short in motor or in motor wiring<br>3. Controller failure. |
| 4,3  | 0000 000                           | EEPROM fault                            | 1. EEPROM failure or fault.   |
| 4,4  | 0000 0000                          | power section fault                     | 1. EEPROM failure or fault.<br>2. Short in motor or in motor wiring.<br>3. Controller failure.                              |

\*NOTE: A KSI (key switch input) system problem is a specific HPD (high pedal disable) type operational fault, caused by the operator activating the Fwd/Rev drive pedal before turning on the main key switch or activating the throttle before sitting on the seat. This can be cleared by returning the operator's drive pedal to neutral and cycling the key switch.

## Removal and Installation

### Drive Pedal Replacement

**⚠ WARNING!** Disconnect the machine's battery pack connector (13) before servicing.

1. See Figure B. Remove the 5 Screws (BB) securing the Drive Pedal (CC) to the floor.
2. Disconnect the Potentiometer electrical connector and remove the Drive Pedal (CC) from the machine.
3. Install new pedal in reverse order.

**⚠ NOTE:** The Potentiometer does not require adjustment.

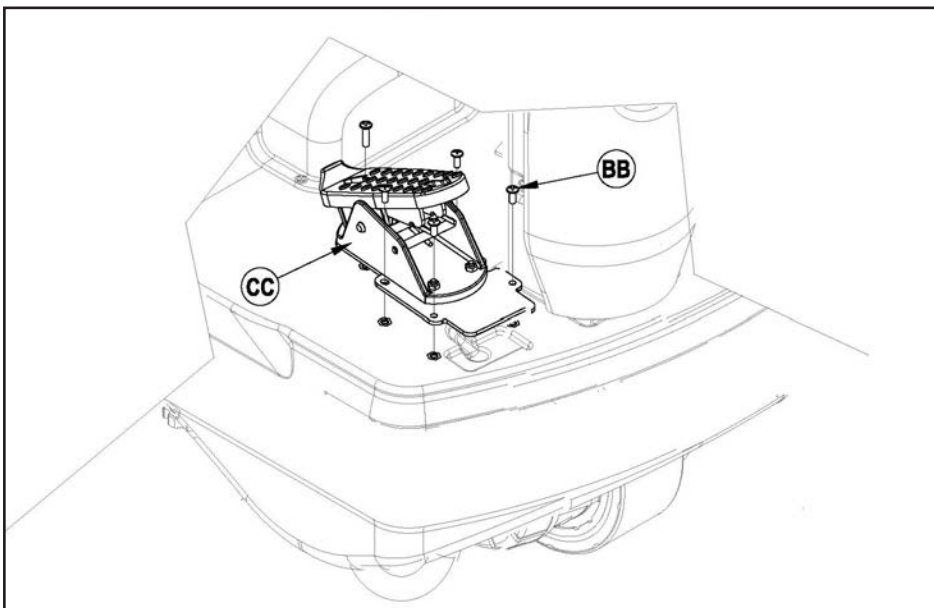

Drawing depicts typical assembly but may not match your machine precisely.

See Photo

Figure B

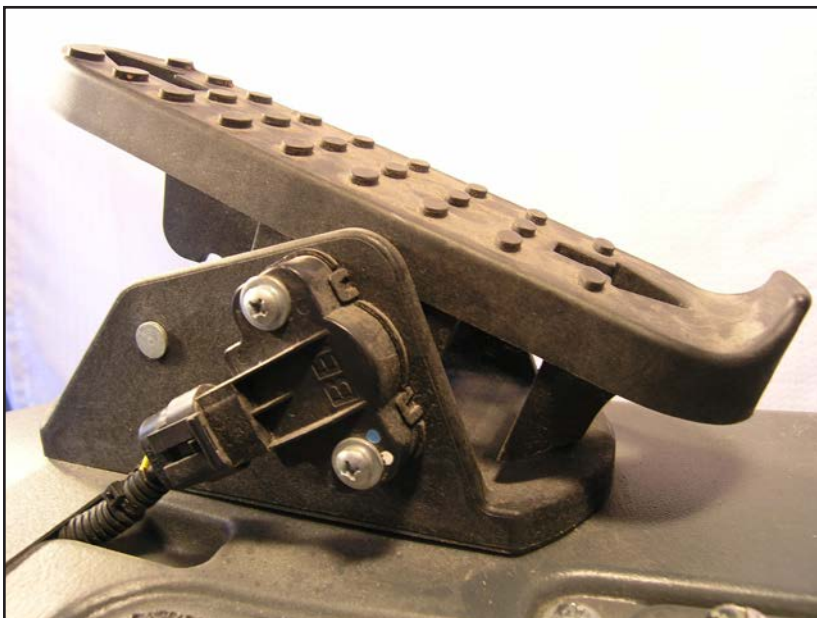

## Potentiometer Testing

The Potentiometer is part of the drive pedal assembly. It is not serviced separately and does not require adjustment. The potentiometer is pre-set at the factory and needs service only when replaced.

### Testing the Potentiometer

*Note: The pot doesn't have to be removed from the drive pedal assembly to test.*

1. Jack the front drive wheel off the floor and support the machine with jack stands and wheel chocks.
2. Do not remove the the throttle potentiometer.
3. Test the pedal signal with a volt meter with the harness connected and the pedal installed on the machine.
4. **See Figure A.** Connect the meter leads to each of the outside connections on the potentiometer. The meter should read approximately 4.6V to 5.02V.
5. Next move the test leads to the number two and number three terminals as shown in the lower picture in Figure A to validate the signal voltage. (The range of readings for the signal voltage should be 2.19 V to 2.4 V at neutral , .8 V to 5 V over the entire range of travel , .87 V to 2.19 V in reverse and lastly 2.19 volts to 4.1 volts in forward.

*Note: The drive pedal is shown without the machine wiring harness connector for clarity. Do not disconnect the drive pedal harness connector.*

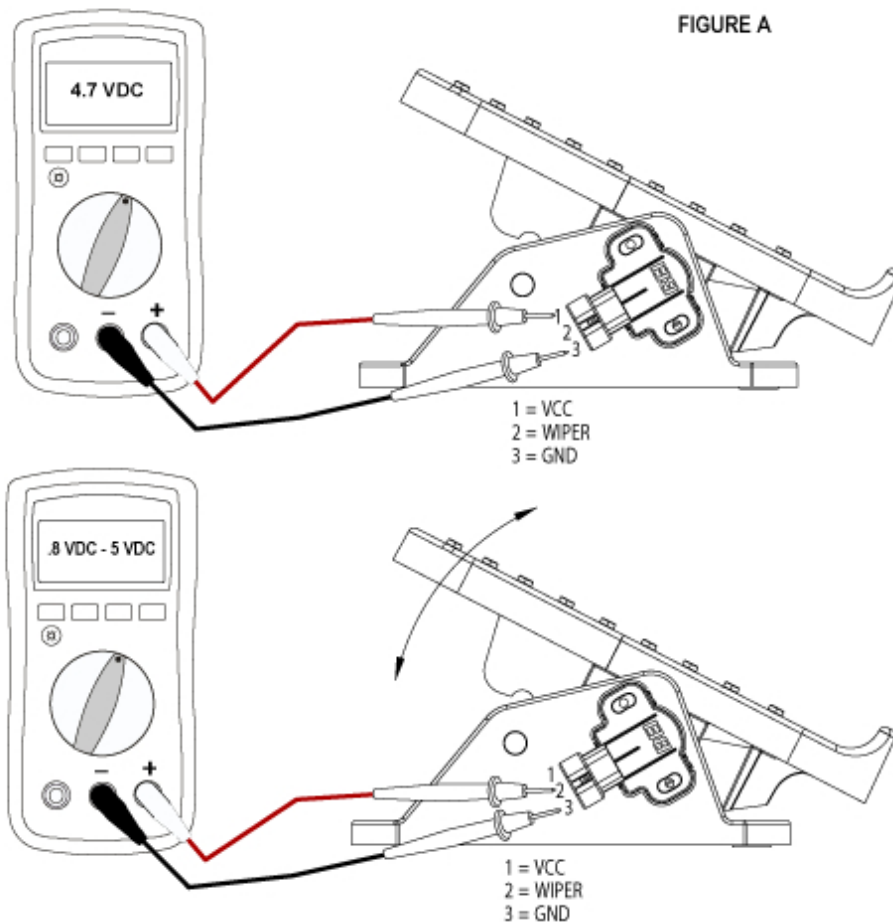

## Replacing the Drive Wheel Assembly

**⚠ WARNING!** Park the machine on a dry flat surface, turn the main key switch (J) to the Off position and disconnect the battery pack at the red connectors inside the battery compartment.

Place bottle jack here

1. Block the rear wheels.

2. Jack up the front of the machine using a bottle jack on the frame member, or use a hoist to lift up the front end of the machine.

3. See Figure W-1. Using a 17mm socket, loosen but don't remove the four bolts (Shown in photo - 2 of 4) at the steering sprocket to allow the chain to release some.



Figure W-1

4. Using a 3/8" magnetic socket, remove the four bolts holding the charger in place, and remove the charger and bottom plate. (Figure W-2).

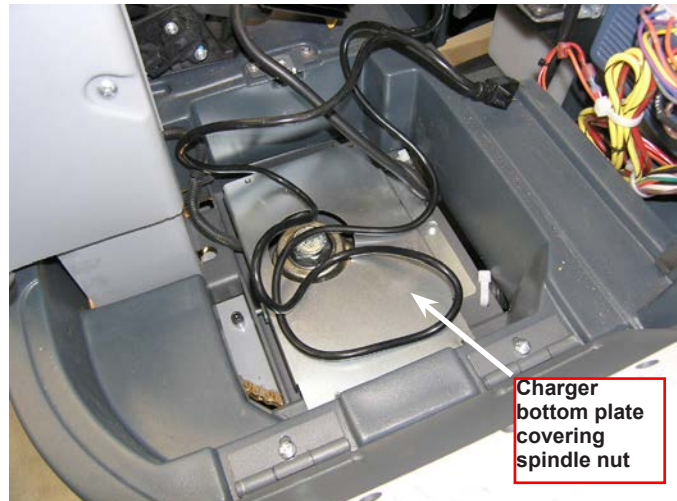

Figure W-2

5. See Figure W-3. Using a 1 7/16" socket, remove the hex nut at the top of the Spindle Weldment.



Figure W-3

6. See Figure W-4. Turn the Drive Wheel to the right and remove the motor wiring cover (C).

7. Using a 13mm and a 7mm socket, remove the nuts and wires from the drive motor.

8. Turn the motor towards the left. Using a 7/16" socket and wrench, remove the P-clamp.

9. Jack up the front end of the machine enough to allow the wheel to slip free from the machine.

10. See Figure W-1. Using a 17mm socket, remove the four bolts (A) at the top to free the motor from the Steering Plate.

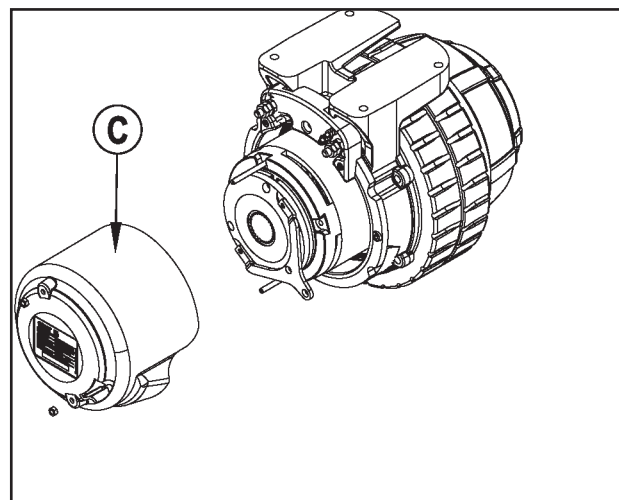

Figure W-4

11. Reassemble the drive wheel in reverse order, attaching the motor wires as shown in Figure W-5.

**⚠ Caution!** Use a Torque Wrench set at 20 ft-lb to retighten the 1 7/16" hex nut at the top of the steering spindle.

**⚠ Note:** Orient the wires in such a way as to minimize bending at the crimps for optimum motor performance. There are (2) each YEL/BLK and RED/GRN going to each post.

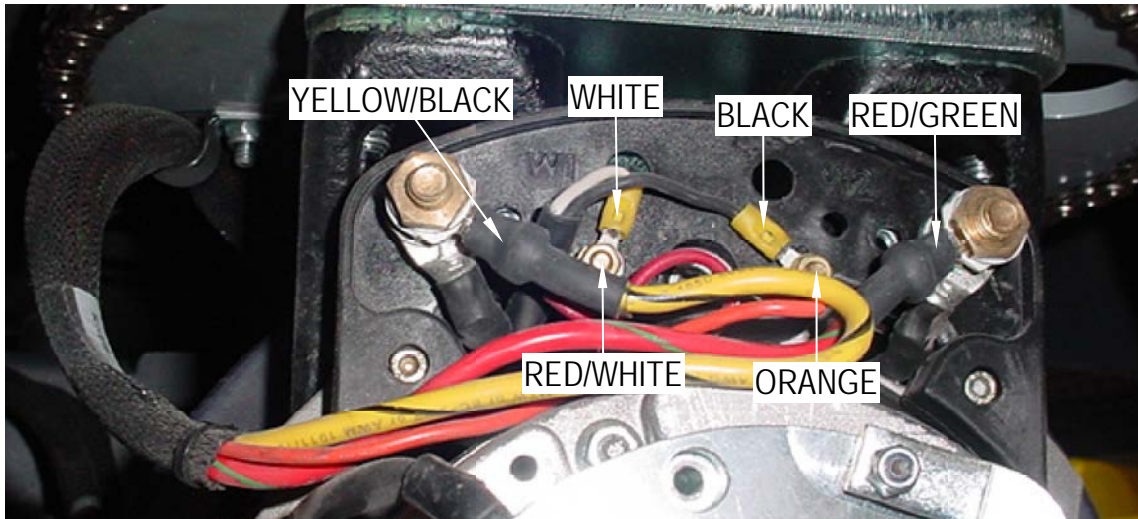

Figure W-5

## Replacing the Drive Tire

The Drive Tire is assembled as shown in Figure W-6:

1. To replace the tire, follow steps 1-3 of “Replacing the Drive Wheel Assembly.” Then follow Figure W-6 and step through assembly from A through E as shown.
2. Remove the six metric socket head screws.
3. Use Tire Puller Kit (part # 56422174) to replace the tire.

Reassemble in reverse order.

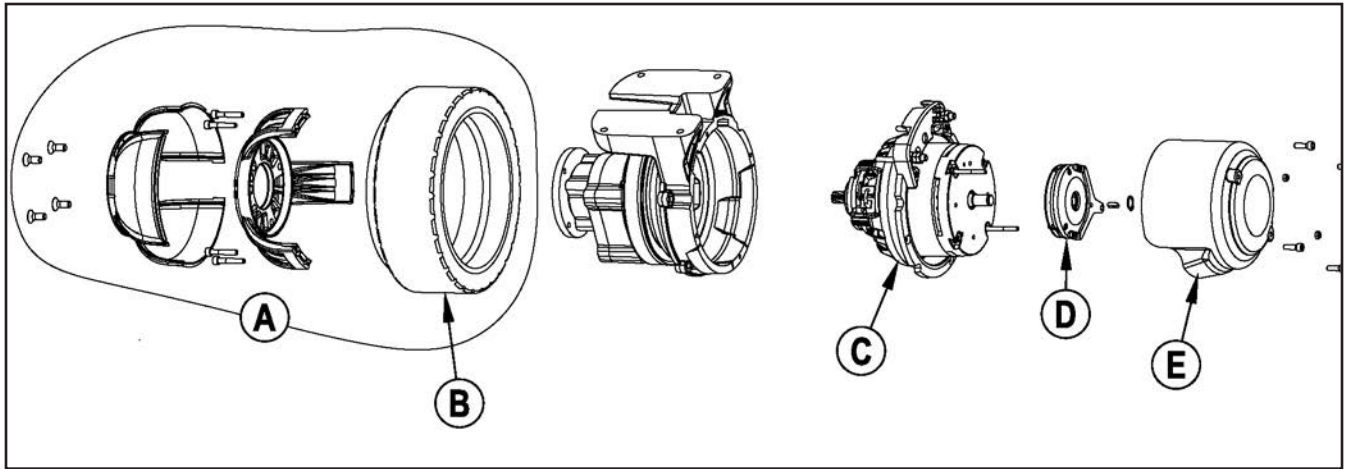

Figure W-6

In addition to carbon brushes, parts available for replacement are:

See figure W-6.

- tire with hub (A)
- tire (B)
- motor (C)
- parking brake (D)
- motor cover (E).

## Inspecting/Replacing the Drive Wheel Assembly Carbon Brushes

**⚠ Important!** To remove/replace/inspect the Carbon Brushes, observe the following:

1. The motor must come off of the machine.
2. The motor assembly must be kept vertical while being disassembled to prevent loss of gear oil.

**⚠ WARNING!** Park the machine on a dry flat surface, turn the main key switch to the Off position and disconnect the battery pack at the red Anderson connectors inside the battery compartment.

1. Follow the instructions in “Replacing the Drive Wheel Assembly”.
2. Place the motor assembly upright, motor side up, as shown.

**Caution!** To prevent gear oil from draining from the gearbox, disassemble the motor with the Drive Wheel assembly in a vertical position. If some oil is lost, drain completely and refill the oil as indicated at the bottom of the page.

3. See Figure W-7 and photos. Remove the four metric socket head cap screws (A) securing the electric motor to the casting.
4. Use a hard piece of wood or a brass drift punch to tap the motor mounting flange (3 notched locations (B)) to loosen.
5. Grip the motor/brake end bell and pull the motor (C) up and out of its housing.
6. Inspect the 4 carbon brushes and springs. A new carbon brush measures 3/4". If less than 1/4", replace.
7. Clean the foam filters, and blow out the motor.
8. If gear oil has been lost, drain and replace with 4.5856 oz (130 g) of Mobilgear 600 XP 150 or AGIP BLASIA 150 gear oil.
9. When placing the motor back into the housing, the brushes can be spring-flexed aside for easy insertion. Release the spring tension on the brushes after the motor is in place.

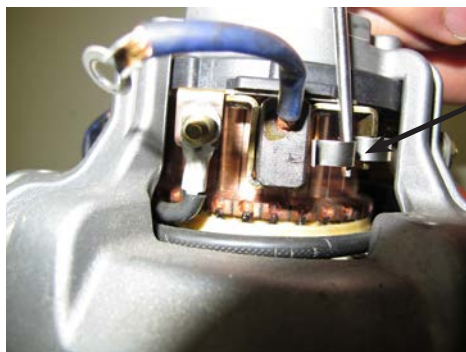

Changing the  
Motor brushes  
- 4 total

See photos next page

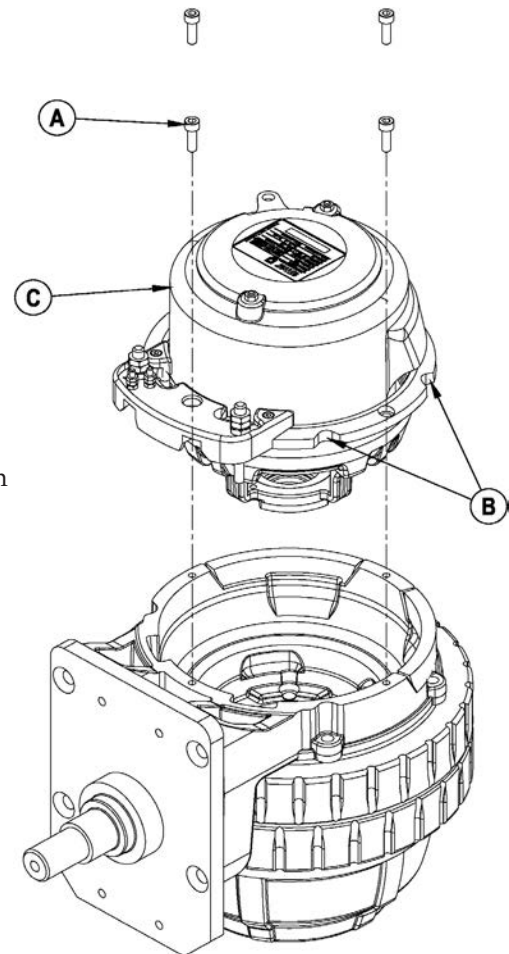

Figure W-7



1. Turn motor assembly over and expose the brushes.
2. Locate brushes and retainer springs (clips).



3. Using a screwdriver or other similar tool, release the tension on the springs to allow the brushes to be removed.

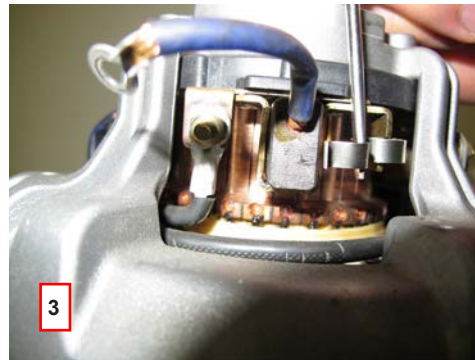

4. Remove, inspect the brushes, then clean or replace the brushes.

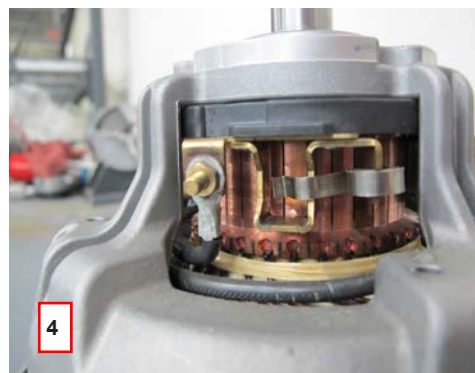

## Specifications

|                      |   |
|----------------------|---|
| Drive Wheel          | Diameter: 9.84 in (25 cm)      Width: 3.15 in (80 cm) |
|                      | Type/Material: Blue Urethane                          |
| Drive Motor          | 1.05 HP      (780 watts)                              |
| Max. Transport Speed | Fwd: 3.91 mph (6.30 kph)                              |
|                      | Rev: 2.61 mph (4.20 kph)                              |

## Special Tools

1. Curtis Programmer unit 1311

The part number of the handheld programmer is 56409441.

**⚠** *NOTE: If you have a programmer with a serial number before 2100 you will need to update your programmer. A free upgrade kit is available, order part number 56409822. Also a different quad 4 pin programmer cable (PN 56409823) is needed to link the programmer to the controller plug-in port.*

2. Tire Puller Kit (part # 56422174)

