



## Electronic Service Manuals

This electronic document is provided as a service to our customers. We do not create the contents of the information contained in this document. Should you have detailed questions pertaining to the information contained in this document, you may contact Michco, or the manufacturer which provided the original information in this electronic deliverable. Michco's only part in this electronic deliverable was the electronic assembly process. By providing this manual on line we are not guaranteeing parts availability.

You may contact Michco through the following methods:

Phone (517) 484-9312 or (800) 331-3339

2011 N. High St. -- Lansing, Michigan -- 48906

Fax: (517) 484-9836

Email: [CustServe@Michco.com](mailto:CustServe@Michco.com)

Web site: [www.Michco.Com](http://www.Michco.Com)

Parts Web site: [www.FloorMachineParts.Com](http://www.FloorMachineParts.Com)

Order Parts on Line at:

**[www.FloorMachineParts.Com](http://www.FloorMachineParts.Com)**

Directly to Parts & Service:

By Email: **[Shop@Michco.com](mailto:Shop@Michco.com)**

By Fax: (517) 702-2041

By Voice: Use numbers above.

***Serving the Cleaning Industry Since 1922***

Notice: All copyrighted material remains property of original owners, all trademarks are property of respective owners. Manuals are subject to Manufacturer's reproduction limitations. Originals or reproductions were provided by manufacturers through a request. We make no warranty as to the correctness of information provided in this document and you assume all risk. By placing these manuals on line we are not declaring our corporation to be an manufacturer authorized dealer or provider, please check our web site for authorized manufacturers we represent.

# BRX 700

SERVICE MANUAL

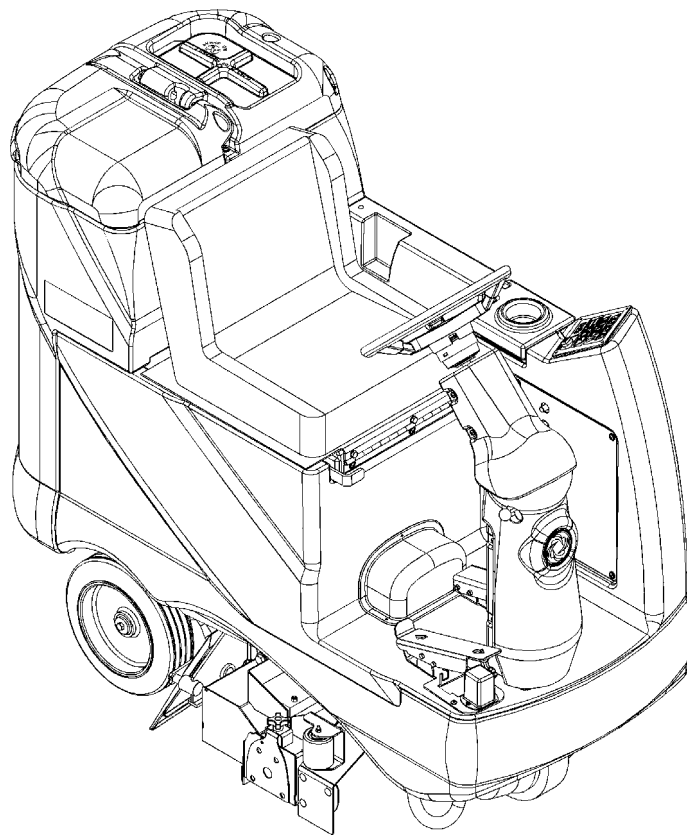

MODEL: 56314019

1/09 revised 10/09  
FORM NO. 56043128

# TABLE OF CONTENTS

GENERAL INFORMATION .....	2
SAFETY INSTRUCTIONS .....	3
SPECIFICATIONS & MAINTENANCE .....	4-6
PM CHECKLIST .....	7-8
KNOW YOUR MACHINE .....	9-15
STEERING SYSTEM .....	16-17
STEERING COLUMN ASSEMBLY SHROUD REMOVAL .....	16
STEERING CHAIN REMOVAL AND TENSIONING .....	17
WHEEL DRIVE SYSTEM .....	18-27
GENERAL FUNCTIONAL OVERVIEW .....	18
DRIVE MOTOR SYSTEM CONTROLLER FUNCTION OVERVIEW .....	18
WHEEL DRIVE TROUBLESHOOTING GUIDE .....	21
STEERING SPINDLE & WHEEL DRIVE MOTOR ASSEMBLY REMOVAL .....	22
DRIVE TIRE REMOVAL .....	22
BRAKE ADJUSTMENT .....	24
DRIVE WHEEL BRAKE STRAP REPLACEMENT .....	25
WHEEL DRIVE MOTOR CARBON BRUSH INSPECTION .....	25
POTENTIOMETER REMOVAL & TESTING .....	26
POTENTIOMETER INSTALLATION & ADJUSTMENT .....	27
DRIVE PEDAL NEUTRAL ADJUSTMENT & PEDAL REPLACEMENT .....	27
SCRUB BRUSH SYSTEM .....	28-33
FUNCTIONAL OVERVIEW .....	28
SCRUB BRUSH SYSTEM TROUBLESHOOTING .....	29
SCRUB DECK REMOVAL .....	30
BRUSH DECK ACTUATOR REMOVAL .....	31
SCRUB BRUSH MOTOR(S) REMOVAL .....	32
SCRUB BRUSH BELT REPLACEMENT .....	32
SCRUB BRUSH SYSTEM MAINTENANCE .....	33
SCRUB BRUSH REMOVAL & INSTALLATION .....	33
SOLUTION SYSTEM .....	34-39
FUNCTIONAL OVERVIEW .....	34
OPERATIONAL OVERVIEW OF THE SOLUTION PUMP & SOLENOID FUNCTIONS .....	35
TROUBLESHOOTING GUIDE .....	36
MAJOR COMPONENTS SPECIFICATIONS .....	37
NOZZLE MAINTENANCE .....	37
NOZZLE FIXTURE INSTALLATION .....	37
SOLUTION PUMP REMOVAL .....	38
SOLUTION SOLENOID VALVE ASSEMBLY REMOVAL .....	38
SOLENOID VALVE DISASSEMBLY AND CLEANING .....	39
RECOVERY SYSTEM .....	40-48
FUNCTIONAL OVERVIEW .....	40
VACUUM MOTOR CIRCUIT OVERVIEW .....	41
VACUUM SYSTEM ELECTRICAL CIRCUIT OVERVIEW .....	42
TROUBLESHOOTING GUIDE .....	43
VACUUM / RECOVERY SYSTEM SERVICE MAINTENANCE CHECKLIST .....	43
MAINTENANCE OF VACUUM FILTER AND FLOAT CAGE .....	43
VACUUM MOTOR(S) REMOVAL .....	45
RECOVERY TANK REMOVAL .....	45
RECOVERY TANK BLADDER REMOVAL .....	46
RECOVERY TANK BLADDER INSTALLATION .....	46
VACUUM SHOES REMOVAL FOR MAINTENANCE .....	48

# TABLE OF CONTENTS

ELECTRICAL SYSTEM .....	49-76
BATTERIES / CHARGERS SPECIFICATIONS .....	49
INSTALL THE BATTERIES .....	49
DESCRIPTION OF THE BATTERY LOW VOLTAGE CUTOUT FEATURE .....	50
DESCRIPTION OF THE BATTERY CONDITION INDICATORS .....	50
CHARGING THE BATTERIES .....	50
BATTERY MAINTENANCE .....	51
BATTERY TESTING .....	51
ACTUATOR DRIVE NUT ADJUSTMENT .....	52-53
CURTIS SPEED CONTROL .....	54-57
MAIN CONTROL BOARD FUNCTIONAL OVERVIEW .....	58
MAIN CONTROL BOARD TROUBLESHOOTING GUIDE .....	58
MAIN CONTROLLER ERROR CODES .....	58-59
MAIN CONTROLLER SERVICE TEST MODE .....	60-63
MAIN CONTROL BOARD SPECIAL PROGRAM OPTIONS .....	64-69
ELECTRICAL COMPONENT LOCATION (before SN 1839732) .....	71
WIRING SCHEMATIC (before SN 1839732) .....	72
WIRING DIAGRAM (before SN 1839732) .....	73
WIRING DIAGRAM (after SN 1839732) .....	74
WIRING SCHEMATIC (after SN 1839732) .....	75
ELECTRICAL COMPONENT LOCATION (after SN 1839732) .....	76

**Note:** All references to right, left, front, or rear in this manual are as seen from the operator's stand-point.

# GENERAL INFORMATION

## INTRODUCTION

This manual will help you get the most from your Nilfisk Rider Extractor. Read it thoroughly before servicing the machine.

**Note: Bold numbers and letters in parentheses and underlined indicate an item illustrated on pages 9-10 i.e. (B).**

This product is intended for commercial use only.

## PARTS AND SERVICE

Repairs, when required, should be performed by your Authorized Nilfisk Service Center, who employs factory trained service personnel, and maintains an inventory of Nilfisk original replacement parts and accessories.

Call the NILFISK DEALER named below for repair parts or service. Please specify the Model and Serial Number when discussing your machine.

(Dealer, affix service sticker here.)

## NAME PLATE

The Model Number and Serial Number of your machine are shown on the Nameplate on the machine. This information is needed when ordering repair parts for the machine. Use the space below to note the Model Number and Serial Number of your machine for future reference.

MODEL NUMBER \_\_\_\_\_

SERIAL NUMBER \_\_\_\_\_

## TRANSPORTING THE MACHINE

### CAUTION!

Before transporting the machine on an open truck or trailer, make sure that . . .

- The machine is tied down securely - see tie-down locations **(26)**.
- All access doors and covers are secured (tape and strap as necessary).
- The machine parking brake is set.

## TOWING

### CAUTION!

If the machine must be towed or pushed, make sure the Key Switch (Main Power) **(J)** is in the OFF position and do not move the machine faster than a normal walking pace (2-3 mph, 3-5kph) and for short distances only.

## OTHER MANUALS AVAILABLE

The following manuals are available from the Nilfisk Literature Service Department, for your Rider Scrubber:

- Parts List - Form Number 56042511
- Operation Manual - Form Number 56041540 (Danish, Norwegian, Swedish, Finnish)  
56041541 (English, German, French, Netherlands)  
56041542 (Spanish, Portuguese, Italian, Greek)

# CAUTIONS AND WARNINGS

## SYMBOLS

Nilfisk uses the symbols below to signal potentially dangerous conditions. Always read this information carefully and take the necessary steps to protect personnel and property.

### **DANGER!**

Is used to warn of immediate hazards that will cause severe personal injury or death.

### **WARNING!**

Is used to call attention to a situation that could cause severe personal injury.

### **CAUTION!**

Is used to call attention to a situation that could cause minor personal injury or damage to the machine or other property.

## GENERAL SAFETY INSTRUCTIONS

Specific Cautions and Warnings are included to warn you of potential danger of machine damage or bodily harm.

### **WARNING!**

- This machine shall be used only by properly trained and authorized persons.
- While on ramps or inclines, avoid sudden stops when loaded. Avoid abrupt sharp turns. Use low speed down hills. Clean only while ascending (driving up) the ramp.
- Keep sparks, flame and smoking materials away from batteries. Explosive gases are vented during normal operation.
- Charging the batteries produces highly explosive hydrogen gas. Charge batteries only in well-ventilated areas, away from open flame. Do not smoke while charging the batteries.
- Remove all jewelry when working near electrical components.
- Turn the key switch off (O) and disconnect the batteries before servicing electrical components.
- Never work under a machine without safety blocks or stands to support the machine.
- Do not dispense flammable cleaning agents, operate the machine on or near these agents, or operate in areas where flammable liquids exist.
- Do not clean this machine with a pressure washer.

### **CAUTION!**

- This machine is not approved for use on public paths or roads.
- This machine is not suitable for picking up hazardous dust.
- When operating this machine, ensure that third parties, particularly children, are not endangered.
- Before performing any service function carefully read all instructions pertaining to that function.
- Do not leave the machine unattended without first turning the key switch off (O), removing the key and applying the parking brake.
- Turn the key switch off (O) before changing the brushes, and before opening any access panels.
- Take precautions to prevent hair, jewelry, or loose clothing from becoming caught in moving parts.
- Use caution when moving this machine in below freezing temperature conditions. Any water in the solution or recovery tanks or in the hose lines could freeze, causing damage to valves and fittings. Flush with windshield washer fluid.
- The batteries must be removed from the machine before the machine is scrapped. The disposal of the batteries should be safely done in accordance with your local environmental regulations.

**SAVE THESE INSTRUCTIONS**

# SPECIFICATIONS

## General Specifications

	English (Metric)
Machine Length	60 in. (152cm)
Machine Height	53 in. (134.6cm)
Machine Chassis Width w/out deck	29 in. (73.6cm)
Machine Width w/deck	31 in (78.7cm)
Total Rated Machine Current (2) brush	65 Amps
Solution Tank Capacity	45 gal. (170l.)
Recovery Bladder Capacity	25 gal. (95l.)
Solution Flow Rate (Maintenance)	.55 GPM (2 liter/minute)
(Restoration)	1.0 GPM (4 liter/minute)
Sound power level as per ISO 3744 (at operator)	73 dB(A)
Transport Speed ( <b>Fwd.</b> Maximum)	4.2 MPH / 370 FPM (6.8km/hr)
Transport Speed ( <b>Rev.</b> Maximum)	2.9MPH / 259 FPM (4.7km/hr)
Wheel Drive Motor	1.1 hp, 840 watt
Vacuum Motor (3 stage) (2 motors in parallel)	.8 hp, 600 watt
Vacuum Water Lift (Sealed)	78 in.
(Open Hole Adapter 1")	25 in.
Power Source (Batteries) STD	(6) 6V/238 @ 20 hour rate
Battery Weight (each)	66 lbs. (30kg)
Battery Compartment Size	
Height (Max.)	14.5 in. (36.8cm)
Width (Max.)	22.25 in. (56.5cm)
Length (Max.)	25.25 in. (64.1cm)
Calculated Battery Run Time	3-3.5 hrs.
Battery Chargers – see Electrical System <i>Battery Section</i>	
Scrub Brush Size	
Diameter	5.75 in. (14.6cm)
Length	27 in. (68.6cm)
Scrub Brush Motors (2)	.75 HP / 560 watts
Scrub Brush Speed	900 RPM
Minimum Aisle Turn Width	63 in. (160cm)
Machine Net Weight*	625 lbs. (283kg)
Machine Gross Weight**	1,570 lbs. (712kg)
Cleaning Width (scrubbing path)	28 in. (71cm)
Coverage Rate Per Hour (Maintenance)	18,500 ft <sup>2</sup> (1720 m <sup>2</sup> )
Coverage Rate Per Hour (Restoration)	8,000 ft <sup>2</sup> (745 m <sup>2</sup> )
Approvals:	ETL and CE

\***Net Weight:** Standard machine without options, empty solution and recovery tanks, without removable scrub brushes and no batteries installed.

\*\***Gross Weight:** Standard machine without options, full solution tank and empty recovery tank, with removable scrub brushes and 305 AH batteries.

\*\*\*Listings for watts are maximum values.

**SPECIFICATIONS**

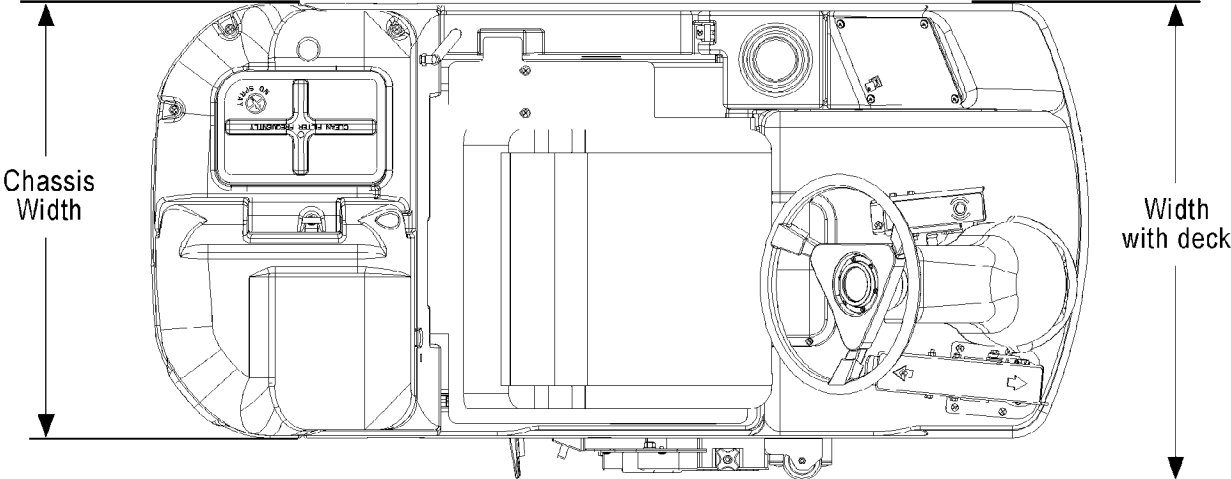

**TOP VIEW**

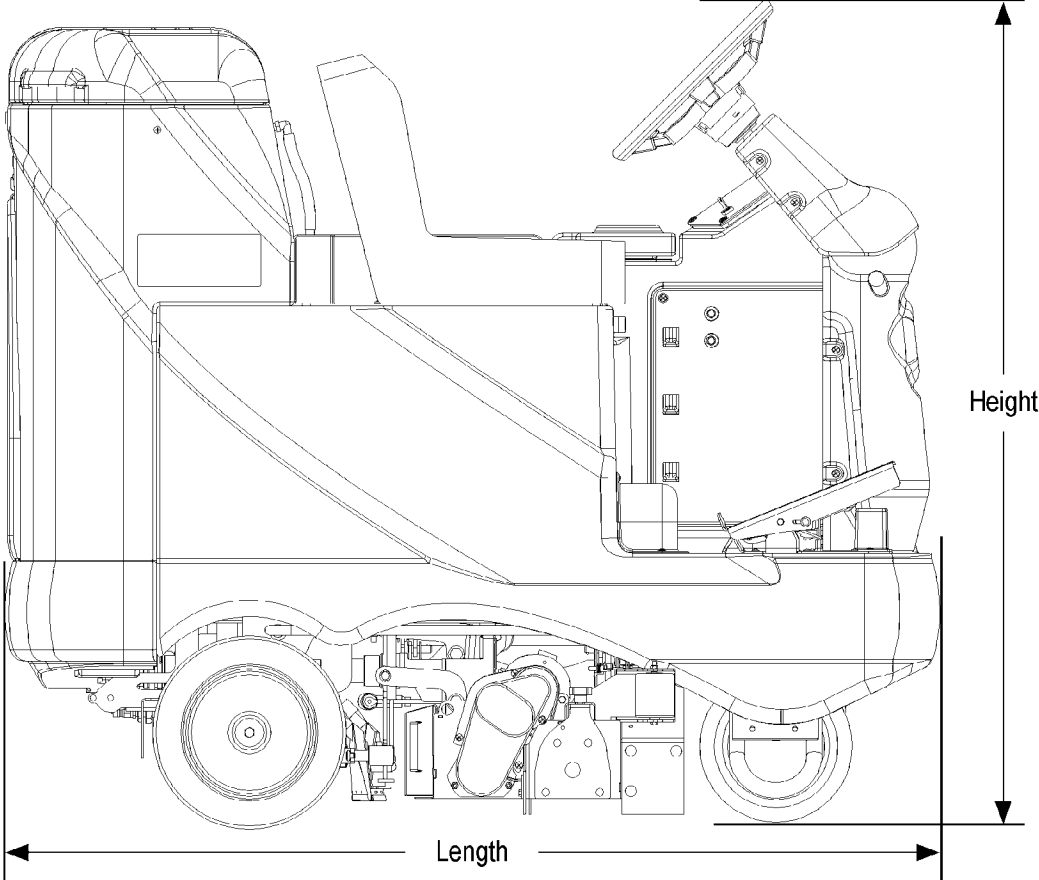

**RIGHT SIDE VIEW**

# MAINTENANCE

## MAINTENANCE SCHEDULE

Maintenance intervals given are for average operating conditions. Machines used in severe operational environments may require service more often.

MAINTENANCE ITEM	Daily	Weekly	Monthly	Yearly
Charge Batteries	•			
Check/Clean Tanks & Hoses	•			
Check/Clean/ Power Brush(s)	•			
Check/Clean Vacuum Shoes	•			
Check/Clean Vacuum Shut-Off Float	•			
Check/Clean the vacuum motor foam filter(s)	•			
Empty Debris Hopper	•			
Clean Spray Nozzles		•		
Check Each Battery Cell(s) Water Level		•		
Inspect Brush Deck Skirts		•		
Inspect and clean Solution Filter		•		
Check Foot/ Parking Brake for Wear & Adjustment		•		
Lubrication - Grease Fittings			•	
* Check Carbon Brushes				•

Note: See the individual machine system sections for maintenance information.

\* Have Nilfisk:

Check vacuum motor carbon brushes (Qty 2) once a year or after 300 operating hours.

Check brush motor carbon brushes (Qty 4) once a year or after 500 operating hours.

Note if the vacuum or brush motor brushes are 9.5mm (3/8 inches) or shorter, replace them.

Check wheel drive motor carbon brushes every 500 operating hours. The original length of each brush is 20mm (25/32 inches). Replace when shorter than 9.5 mm (3/8 inches) to obtain the same motor efficiency as a new brush.

## WARNING!

Turn the key switch off, set the parking brake and disconnect the battery before servicing the machine.

## VACUUM SHOE MAINTENANCE

Check the vacuum shoes daily, they can be removed to aid in cleaning, see "Removing the Vacuum Shoes". Remove any built-up string, hair or carpet fibers.

## SPRAY NOZZLE MAINTENANCE

Remove the spray nozzles once a week. Soak the nozzles overnight in a vinegar solution to remove chemical deposits.

## LUBRICATING THE MACHINE

Once a month, pump a small amount of grease into each grease fitting on the machine until grease seeps out around the bearings.

**Grease fitting locations are:**

- Steering Wheel Shaft Universal joint

**Once a month, apply light machine oil to lubricate the:**

- Steering Chain
- General Pivot Points For the Brush Deck Linkage
- Scrub Deck Adjustment Knobs (4)

## CLEANING THE VACUUM MOTOR FILTERS

Clean the vacuum motor filters daily with compressed air. For extremely dirty filters, wash with warm, soapy water and rinse thoroughly with clean water. Allow the filters to dry completely before re-installing in the machine. MAINTENANCE NOTE: Keep a second set of filters on hand to use while first set is drying.

## POWER BRUSH MAINTENANCE

Check the brush(s) daily. Remove any built-up string, hair or carpet fibers. Check the bristle length. Have a service technician change the brush(s) when the brush bristles are worn to 1 inch (25mm).

## Nilfisk BRX 700 PM Checklist

Customer \_\_\_\_\_

Address \_\_\_\_\_

City \_\_\_\_\_ St \_\_\_\_\_ Zip \_\_\_\_\_

Model \_\_\_\_\_ Serial \_\_\_\_\_ Hours \_\_\_\_\_

**Defect Codes**  
**A** needs adjustment  
**B** binding  
**C** dirty or contaminated  
**D** damaged, bent or torn  
**L** leaks  
**M** missing  
**W** worn out

Ref	OPERATIONAL INSPECTION ITEMS	OK	Defect Codes (circle)	Does Not Work
1	Steering		A B	
2	Drive Pedal Operation (check for Fwd/Rev Drive & any neutral creep)		A B D	
3	Seat Safety Switch		A D	
4	Brakes (Service & Parking)		A B W	
5	Drive System Performance (reference SVR Manual for Curtis drive programmer speed changes)		noisy sluggish	
6	Scrub System (Raise/Lower and test auto scrubbing functions Maintenance & Restoration)		A B	
7	Vac Shoe Recovery System (Raise/Lower and auto lift in reverse function) (must be programmed on)		A B	
8	Vacuum Performance (sealed water lift 78" and 1- inch open hole adapter 25 inches)		C L W	
9	Solution Control (On/Off and flow volume Maintenance & Restoration)		A B L	
10	Emergency Battery Disconnect Control Lever		B D	
11	Tilt Steering Mechanism and Seat		A B D	
12	Optional Accessories (headlight, safety beacon, etc.)		D	
13	Main Control Board Special Program Options (check all applicable program settings, reference SVR Manual 56043128); Example, Fault Recall Mode, Etc.		Program as needed	
14	Battery Charger Operation		D	

Ref	VISUAL INSPECTION ITEMS	Comments	OK	Defect Codes (circle)	Does Not Work
15	Scrub Brushes, check for wear and rotate	Cylindrical		A B D W	
16	Scrub Brush Motors	Carbon Brushes		B L W	
17	Scrub Brush Drive Belt, wear and tension			A D W	
18	Scrub Brush Deck Actuator Motor			A B D W	
19	Brush Deck Idler Assembly Bearings			D M	
20	Scrub Deck Skirts			A B W	
21	Solution Solenoid Valves (Maintenance & Restoration)			C L	
22	Solution Flow Control Valve			A B D W	
23	Solution Tank, Delivery Hoses & Filter	Clean Filter Screen		C L	
24	Vacuum Motor Carbon Brushes	Wear Limit 3/8"		W	
25	Vacuum Motor Gaskets and Filters			L W	
26	Vacuum Float Ball & Cage Assembly	Clean Float		C M	
27	Recovery Tank Cover Gasket			C D L	
28	Recovery Tank Drain Hose & Cap	Flush		C L	
29	Vacuum Pick-Up Tool & Hoses	Back flush		C L	



# KNOW YOUR MACHINE

- |   |  |
|---|--|
| 1 Recovery Tank Cover                         | 14 Brush Deck                                    |
| 2 Solution Tank Fill Cover                    | 15 Rear Wheel                                    |
| 3 Operator's Seat                             | 16 Battery Compartment (under seat)              |
| 4 Solution Tank Drain Hose                    | 17 Recovery Bladder Shutoff Float                |
| 5 Steering Wheel Tilt Adjust Knob             | 18 Vacuum Motor Filter Housing                   |
| 6 Brake Pedal / Parking Brake                 | 19 Recovery Bladder                              |
| 7 Solution Spray Jets                         | 20 Solution Filter                               |
| 8 Drive Pedal, Directional/Speed              | 21 Recovery Bladder Drain Hose (rear of machine) |
| 9 Vacuum Shoes                                | 22 Machine Battery Connector                     |
| 10 Drive and Steer Wheel                      | 23 Control Panel                                 |
| 11 Wheel Drive Circuit Breaker                | 24 Debris Hopper                                 |
| 12 Control Circuit Circuit Breaker            | 25 Solution Control Valve                        |
| 13 Emergency Stop Switch / Battery Disconnect | 26 Tie Down Locations (3)                        |

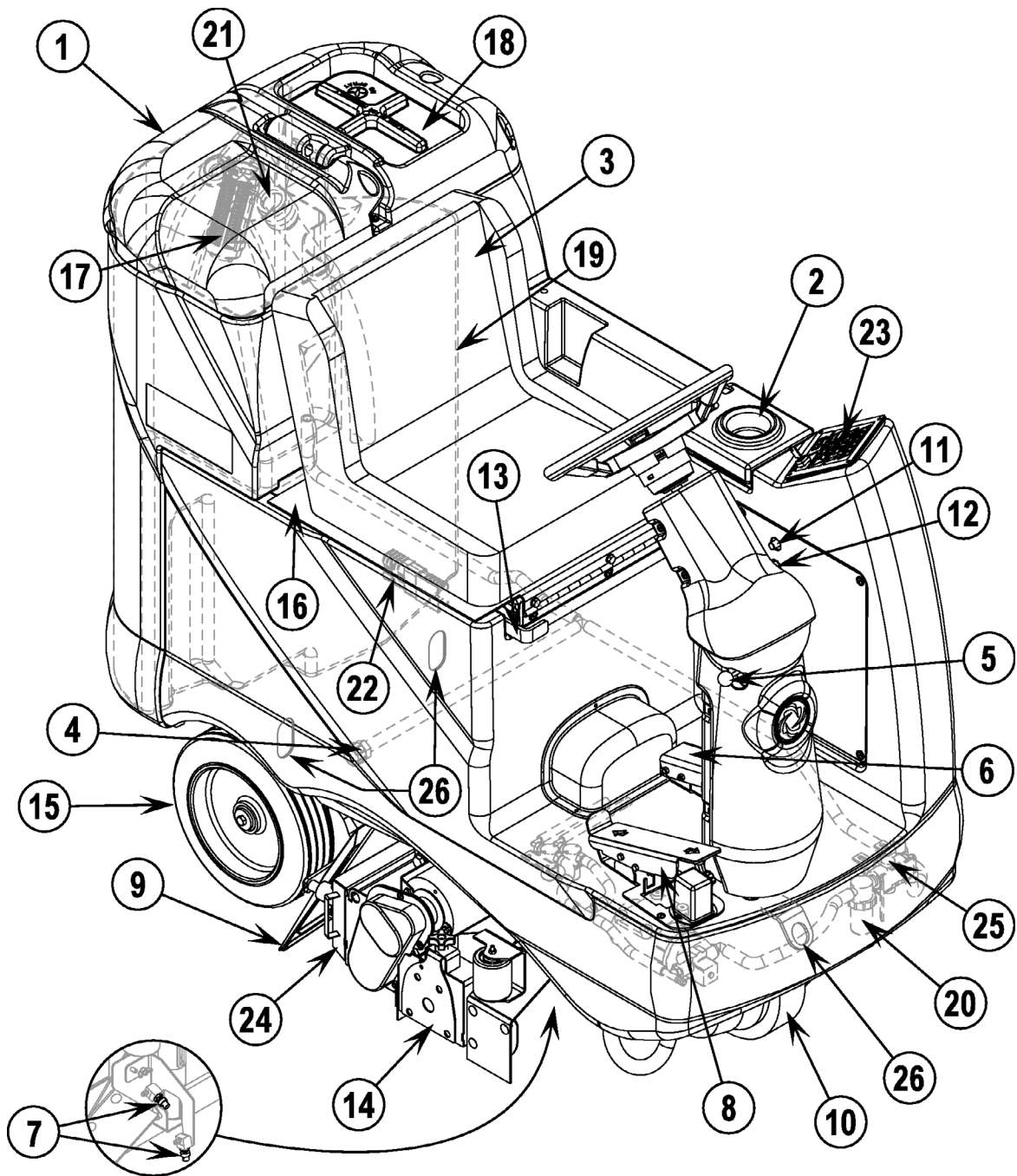

# CONTROL PANEL

- |   |                                  |    |   |
|---|----------------------------------|----|---|
| A | Scrub OFF Indicator              | K1 | Battery Condition Indicator (RED)         |
| B | Scrub OFF Switch                 | K2 | Battery Condition Indicator (YELLOW)      |
| C | Maintenance Mode Indicator       | K3 | Battery Condition Indicator (GREEN)       |
| D | Maintenance Mode Switch          | L  | Speed Select Switch (extract / transport) |
| E | Restoration Mode Indicator       | M  | Speed Select Indicator                    |
| F | Restoration Mode Switch          | N  | Horn Switch                               |
| G | Hourmeter Display                | O  | Vacuum Switch                             |
| H | Accessory Vacuum Indicator       | P  | Vacuum System Indicator                   |
| I | Accessory Vacuum ON / OFF Switch | Q  | Solution System Indicator                 |
| J | Key Switch / Main Power          | R  | Solution Switch                           |
| K | Battery Condition Indicators     |    |   |

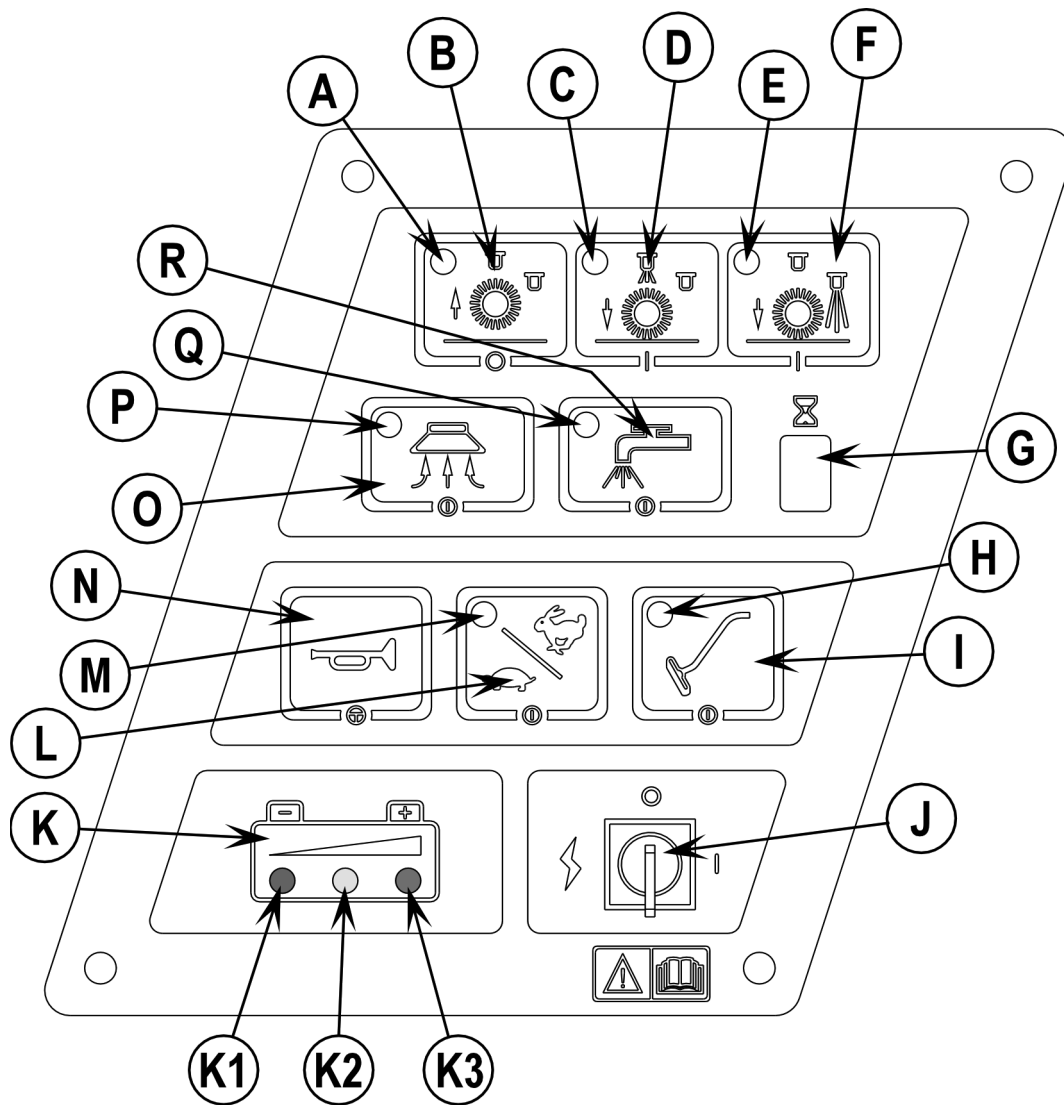

## KNOW YOUR MACHINE DESCRIPTIONS:

**Recovery Tank Cover (1)** – Open to access Recovery Bladder for rinsing and/or cleaning Float Cage.

**Solution Tank Fill Cover (2)** – Open to fill the solution tank, only use low-sudsing liquid detergents designed for carpet extraction. The area around the recovery bladder inside the recovery tank also holds solution. Total capacity is 40 gallons (151 Liters).

**Operator's Seat (3)** – The machine operator sits here. The seat has a safety switch which prevents the machine from moving without an operator in the seat.

**Solution Tank Drain Hose (4)** – Used to empty the solution tank.

**Steering Wheel Tilt Adjust Knob (5)** – Push down on this knob to adjust the Steering Wheel up or down.

**Brake Pedal / Parking Brake (6)** – Push down to stop machine. NEVER leave machine unattended without setting Parking Brake.

**Solution Spray Jets (7)** – Based upon which extraction mode is selected (maintenance or restoration) the solution will be sprayed out one of the two different jets.

**Drive Pedal, Directional / Speed (8)** – The operator can make the machine go forward by pushing forward on it, or reverse by pulling backward on it. The speed is variable depending on how far forward or backward the pedal is moved.

**Vacuum Shoes (9)** – Removes excess solution from carpet after cleaning.

**Drive and Steer Wheel (10)** – Wheel drive motor attached to this wheel to propel machine either forward or reverse. Also attached to Steering Wheel for steering left or right.

**Wheel Drive Circuit Breaker (11)** – Provides overload protection to machine's wheel drive motor, 45 Amp. If it trips, it will pop out. To reset, wait one minute and press the button back in. If any breaker trips repeatedly, have the machine serviced.

**Control Circuit Breaker (12)** – Provides overload protection, 10 Amp. If it trips, it will pop out. To reset, wait one minute and press the button back in. If any breaker trips repeatedly, have the machine serviced.

**Emergency Stop / Battery Disconnect (13)** – Push in on lever to disconnect batteries.

**Brush deck (14)** – Contains brush drive motor(s), brush(s) and solution spray jets.

**Rear Wheel (15)** – These two wheels along with the drive wheel, support the machine. Power and steering are supplied through the front drive wheel.

**Battery Compartment (16)** – Batteries stored here, flip seat panel up to access.

**Recovery Bladder Shutoff Float (17)** – Shuts off vacuum when recovery bladder is full.

**Vacuum Motors' Filter Housing (18)** – Location of Vacuum Motors air intake filters.

**Waste Water Bladder (19)** – Contains waste water as it is recovered from carpet.

**Solution Filter (20)** – Filters solution prior to entering pump and being sprayed on floor.

**Recovery Drain Hose (21)** – Used to empty the recovery bladder.

**Machine Battery Connector (22)** – Batteries plug into this connector, disconnect to charge batteries.

**Control Panel (23)** – Operator Controls found here, see "FUNCTIONAL DESCRIPTION OF CONTROL SWITCHES".

**Debris Hopper (24)** – Collects debris that has been swept up by the machine. Empty and clean daily.

**Solution Control Valve (25)** – This valve should be fully open whenever extracting. Only close this valve before removing the solution filter to prevent loss of solution.

# KNOW YOUR MACHINE

## FUNCTIONAL DESCRIPTION OF CONTROL SWITCHES:

The controls on the BRX 700 were designed with *one touch operation* in mind. For single pass extracting the user can simply depress one switch and all systems on the machine will be ready to go.

For most single-pass extracting operations, the operator should only need to use the top three switches on the control panel. These are the Scrub System Off, Maintenance Extract Mode, and Restoration Extract Mode switches. In the maintenance mode the solution spray is directed at the scrub brush and the flow rate is reduced. The travel speed is limited to a medium speed. In the restoration mode the solution spray is directed at the carpet ahead of the scrub brush and the flow is at maximum. The travel speed is limited to a slow speed.

**Scrub System Off Switch (B)** - Pressing this switch when the scrub system is active will cause the following to occur:

- The scrub brush(s) will turn off and the scrub deck will raise to the up position
- The solution flow will be stopped
- The vacuum will shut off after a 10 second delay
- The travel speed limit will return to the transport speed setting

**Maintenance Extract Mode Switch (D)** – If the scrub system is off, pressing this switch will cause the following to occur:

- The scrub system will be enabled with the system configured for maintenance mode and the scrub deck will be lowered
- The vacuum system will be enabled
- The solution system will be enabled for maintenance mode
- The travel speed will be limited to the maintenance mode speed setting
- As soon as the throttle is moved from the neutral position the scrub brush(s) will start turning and the vacuum will turn on. If the direction is forward the solution flow will start. If the direction is reverse the solution flow will be stopped. It is possible to program the control to automatically raise the scrub deck in reverse. Refer to the Electrical System “*Main Control Board Special Program Options*” for details.

If the restoration mode is selected, pressing this switch will select the maintenance mode. If the maintenance mode is already selected, pressing this switch will have no effect.

**Restoration Extract Mode Switch (E)** – If the scrub system is off, pressing this switch will cause the following to occur:

- The scrub system will be enabled with the system configured for restoration mode and the scrub deck will be lowered
- The vacuum system will be enabled
- The solution system will be enabled for restoration mode
- The travel speed will be limited to the restoration mode speed setting
- As soon as the throttle is moved from the neutral position the scrub brush(s) will start turning and the vacuum will turn on. If the direction is forward the solution flow will start. If the direction is reverse the solution flow will be stopped. It is possible to program the control to automatically raise the scrub deck in reverse. Refer to the Electrical System “*Main Control Board Special Program Options*” for details.

If the maintenance mode is selected, pressing this switch will select the restoration mode. If the restoration mode is already selected, pressing this switch will have no effect.

## FUNCTIONAL DESCRIPTION OF CONTROL SWITCHES (CONTINUED)

**Accessory Vacuum ON/OFF Switch (I)** - This switch is used when an external scrub wand is used. Pressing this switch will turn the vacuum on continuously without regard to the throttle position. It will also enable the solution pump. If the scrub system was on it will be turned off. This includes turning off the scrub brush(s) and raising the scrub deck and turning the solution flow to the scrub deck off. *NOTE: Automatic shutoff of the vacuum motor when the recovery bladder is full is disabled when the wand is enabled. The float in the recovery bladder will still prevent water from entering the vacuum motor, but the motor will not shut off.*

**Key Switch / Main Power (J)** – Main Power Switch.

**Speed Select Switch (L)** – This switch will allow the operator to select a faster travel speed while the scrub system is enabled thereby allowing extracting at a higher rate of speed. This option can be disabled if desired. See the Electrical System “*Main Control Board Special Program Options*” for details.

The transport, maintenance mode, and restoration mode speed limits can be programmed using a Curtis handheld programmer. Refer to the Electrical System “*Main Control Board Special Program Options*” for details.

**Horn Switch (N)** – This switch will sound the horn as long as the switch is held.

The horn also functions as an automatic back-up alarm when the throttle is moved to the reverse position. The volume of the back-up alarm is programmable. It can also be programmed to provide an annunciation feature that will sound whenever the throttle is in the forward position. See the Electrical System “*Main Control Board Special Program Options*” for details.

**Vacuum Switch (O)** - This switch is used to turn the vacuum system on or off. Pressing this switch will alternate between on and off. The vacuum will only turn on when the throttle is moved from the neutral position. It will remain on for 10 seconds after the throttle returns to neutral.

The vacuum also has an automatic shutoff feature that will turn the vacuum and scrub systems off if the recovery bladder becomes full. If this occurs, the status display will show the word “FULL”. This feature can be disabled if desired. The shutoff threshold can also be adjusted if necessary. See the Electrical System “*Main Control Board Special Program Options*” for details.

**Solution Switch (R)** - This switch is used to turn the solution system on or off. Pressing this switch when the scrub system has been activated will alternate between on and off. The solution flow will only turn on when the throttle is moved from the neutral position in the forward direction. The solution flow will turn off if the throttle returns to neutral or is moved to reverse.

# KNOW YOUR MACHINE

## DESCRIPTION OF INDICATORS ON THE CONTROL PANEL:

### Scrub Off Indicator (A):

- This indicator will be green if the scrub system is off and ready to be activated.
- This indicator will be red if the scrub system has been turned off and the scrub deck is not up yet, or if the scrub deck is up and there is no weight on the seat.
- This indicator will flash red if there is a fault in the scrub system.
- This indicator will be off if the scrub system has been activated.

### Maintenance Mode Indicator (C):

- This indicator will be green if the scrub system is on and the maintenance mode has been selected.
- This indicator will be yellow if the maintenance mode has been selected but the throttle is in neutral.
- This indicator will be off if the scrub system is off.

### Restoration Mode Indicator (E):

- This indicator will be green if the scrub system is on and the restoration mode has been selected.
- This indicator will be yellow if the restoration mode has been selected but the throttle is in neutral.
- This indicator will be off if the scrub system is off.

### Hourmeter Display (G):

- The hourmeter display will scroll the hourmeter information only if all of the systems are turned off and the Drive Pedal (8) has been in neutral for at least ten seconds. Immediately once the key switch has been turned on the display will do a self-test (flash 8) to check all segments of the display. Then the hourmeter information will also be displayed. The format for the display of the hours is as follows:

#### Example 123.4 hours

- The display will indicate 1 followed by a short blank period
- The display will indicate 2 followed by a short blank period
- The display will indicate 3 followed by a short blank period
- The display will indicate \_ followed by a short blank period, this is used as a decimal point to indicate tenths of hours
- The display will indicate 4 (tenths) followed by a long blank period
- The display sequence will repeat

### Accessory Vacuum Indicator (H):

- This indicator will be green when the accessory function is on.
- This indicator will be off if the accessory function is off.

### Speed Selector Indicator (M):

- This indicator will be green if a scrub mode has been selected and the faster scrub speed has been selected.
- This indicator will be off if the faster scrub speed has not been selected.

### Vacuum System Indicator (P):

- This indicator will be green if the vacuum is on.
- This indicator will flash green if the vacuum is in the ten second delayed-off condition.
- This indicator will be yellow if the vacuum is enabled but the throttle is in neutral.
- This indicator will flash yellow if there is a vacuum system fault.
- This indicator will be off if the vacuum is off.

### Solution System Indicator (Q):

- This indicator will be green if the solution is on.
- This indicator will be yellow if the solution is enabled but the throttle is in neutral.
- This indicator will flash yellow if there is a solution system fault.
- This indicator will be off if the solution is turned off.

### Power Saving Sleep Function

The BRX 700 is equipped with a battery saving feature that will turn all of the machine systems and accessories off if the machine is left in an idle state for a preset period of time. This sleep mode will only occur if the operator is not on the seat and the wand function is not in use. The sleep mode is indicated by a short duration green flashing scrub system off indicator. The sleep function is automatically cancelled when the operator sits on the seat or any of the control switches are pressed. The sleep delay period is adjustable from 10 to 90 minutes in 10 minute increments. The default period is 10 minutes. It can also be disabled. Refer to the "Main Control Board Special Program Options" for changing the delay period.

## DESCRIPTION OF THE BATTERY CONDITION INDICATORS

The battery condition indicator (**K**) consists of three lights; a green (**K3**), a yellow (**K2**) and a red (**K1**). A fully charged battery pack will measure above 37.6 volts with no load applied (2.09 volts per cell). The BRX 700 is equipped with a low voltage cutout feature that will turn the scrub system off when the batteries are discharged to their minimum level. There are two different cutout levels to accommodate different battery types. See the Electrical System “*Main Control Board Special Program Options*” for details. The voltage levels for the various indications are as follows (the voltages shown represent the voltage under load):

	<b>Standard</b>	<b>Alternate</b>
Green	34.00+	34.50+
Green & Yellow	33.00-33.99	34.00-34.49
Yellow	32.00-32.99	33.50-33.99
Yellow & Red	31.50-31.99	33.00-33.49
Red	31.00-31.49	32.50-32.99
Flashing Red/Cutoff	<31.00	<32.50

**NOTE:** Refer to service manual for selection of alternate cut-off level. Once the low voltage cutout level has been reached (flashing red indicator) the batteries must be **FULLY** recharged (37.6V) to reset the battery condition indicator. The scrub system will not function until the indicator has been reset.

## DESCRIPTION OF ADDITIONAL HOURMETER / STATUS DISPLAY FUNCTIONS

The single character display in the upper right corner of the control panel is primarily used as a display for the hourmeter function. This display is also used to display the following information depending upon which mode the control is in:

- Error codes\*
- Display of control system default parameters\*
- Recovery tank FULL indicator\*

If any of the systems on the machine are on or if the throttle is not in neutral, the display will be blank.

\* NOTE: Reference (in the Electrical System manual section) the Main Control Board Troubleshooting Guide and the Control Board Special Program Options sections. These sections will explain the machine error code descriptions and scrub system controller default parameter changes.

# STEERING SYSTEM

## STEERING COLUMN ASSEMBLY SHROUD REMOVAL

### Upper Column

- 1 See Figure 1. Remove the center Wheel Adapter (A) from the steering wheel. Pry it off using a flat bladed screwdriver.
- 2 Remove the steering shaft retainer Hex Nut (B) (use a 3/4" socket wrench) and the two Washers (C & D). Next pull straight back on the steering wheel to remove it from the metal Wheel Adapter (E).
- 3 Pull off the keyed metal wheel adapter from the steering shaft by using a two-jaw gear puller. With the wheel adapter off the loose Plastic Trim Cup (F) can now be removed.
- 4 Remove the (4) Screws (G) securing the Column Shroud (H) and pull it off from the Column Base (I).

### Lower Column

- 1 Tilt the steering wheel column as far back (close to the seat) as possible.
- 2 Remove the tilt column release Knob (J) (threaded) from its shaft.
- 3 Remove the (4) Screws (K) securing the Lower Shroud (L) and next pull the shroud far enough away from the column base to clear the tilt release shaft through the shroud opening. Note: This will take some effort in prying the flexible plastic shroud around the movable tilt shaft.
- 4 Grip the shroud and pull up to completely release it from the steering column base and the foot brake assembly.

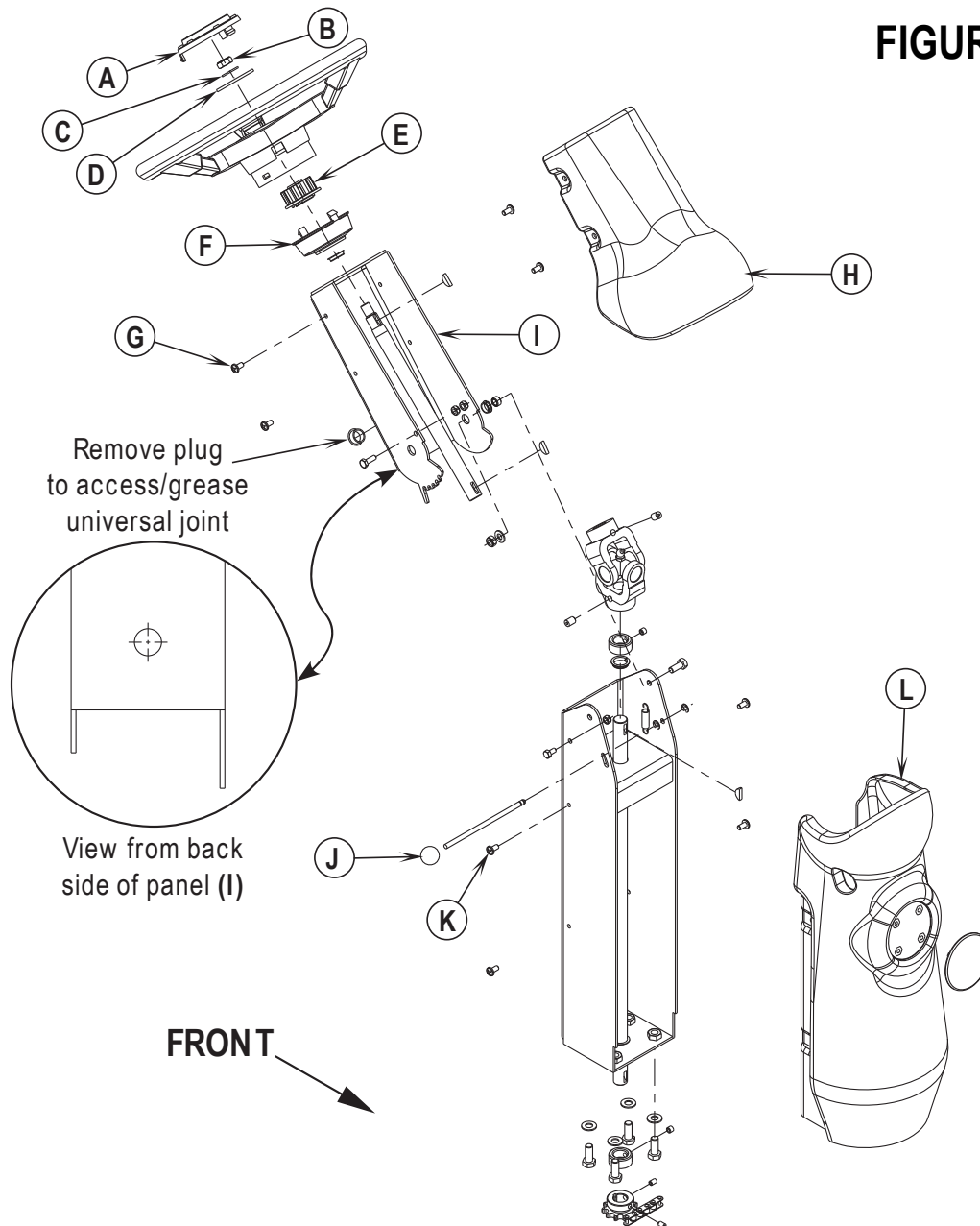

FIGURE 1

## STEERING CHAIN REMOVAL AND TENSIONING

- 1 Turn the master key switch off and separate the battery pack emergency disconnect (13).
- 2 See Figure 2. From underneath the front of the machine loosen the (4) (M) Screws and push the lower steering column to the rear of the machine. This is done to separate the Chain (N) from the Steer Sprocket (O). **Service Note:** Use a 5/8" socket with 3" extension to loosen screws and also correctly position the large hole in the Steer Plate (P) in order to access the far back left screw.
- 3 Remove both Master Links (Q) that secure the chain to the Steer Plate (P) then remove the chain from the chassis.
- 4 Reassemble parts in reverse order and adjust chain tension so that there is about 3/16" – 1/4" (4.7 – 6.4mm) total deflection with moderate pressure applied at the Mid-point (R) (as shown). **Service Tip Note:** Use a pry bar or shims between the chassis and steer column to help secure the tension adjustment when tightening the (4) steering column mounting screws.

### Maintenance

- 1 Inspect the chain for looseness and binding, re-tension the chain to 3/16"-1/4" (4.7 – 6.4mm) deflection by following the above adjustment instructions.
- 2 Keep all of the steer chain links oiled to prevent excessive wear and binding.

**FIGURE 2**

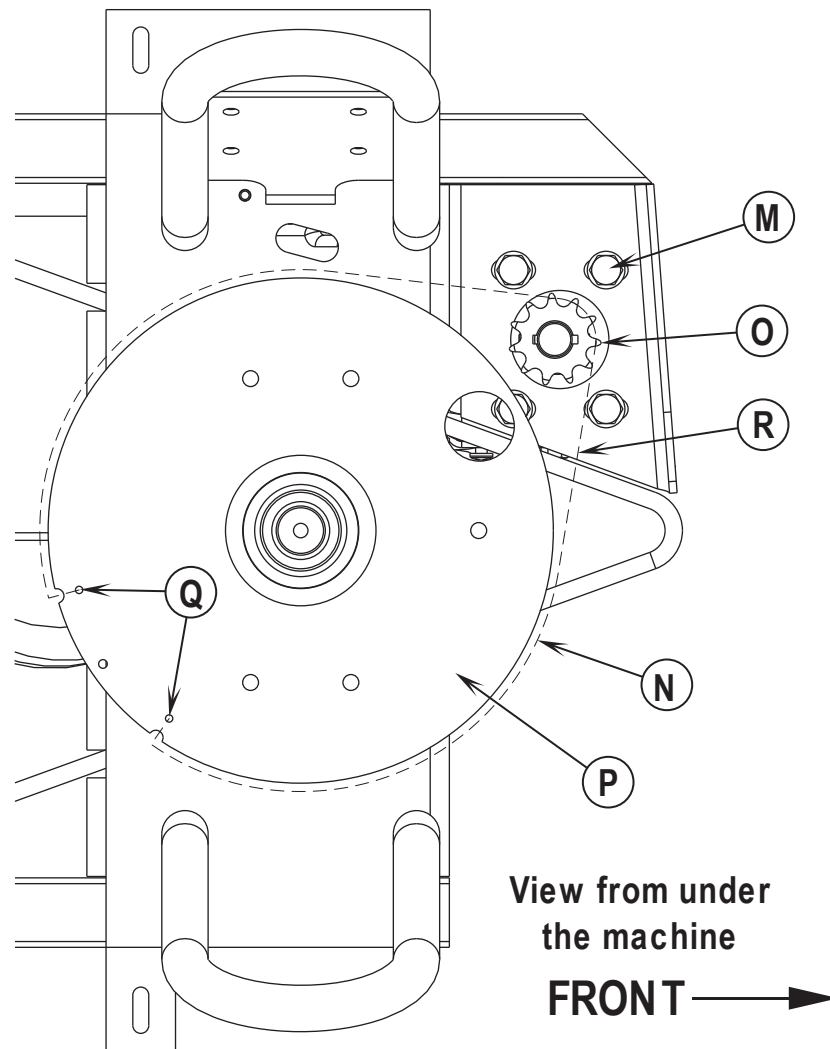

# WHEEL DRIVE SYSTEM

## GENERAL FUNCTIONAL OVERVIEW

See Figures 1 & 2. An 840-watt 1.1 HP (permanent magnet) 36V motor/gear transmission combination wheel unit (M3) is used to propel all machines. A Curtis model 1228 PMC solid state speed controller (A1) regulates (outputs) the variable speed Fwd/Rev wheel drive motor functions. The controller unit is located to the left of the operator seat, behind the electrical access panel. The potentiometer R1 mounted to the operator's foot pedal, inputs to the (A1) controller the machine operator's desired speed and directional demands.

## DRIVE MOTOR SYSTEM CONTROLLER FUNCTION OVERVIEW

See Figure 2. To make the A1 speed controllers internal control circuits operational (power it up) the two switches S1 (key) and S2 (seat) must be closed. This circuit inputs a positive (+) 36V to the A1 speed controls pin terminal #5 (\*KSI). The F2 circuit breaker 45 Amp supplies the positive high current (load) circuit input to the B+ controller terminal (Brn/Blk wire). The black wire from the negative (-) battery standoff supplies the battery ground input to the B- terminal for both the control and load circuits.

See Figure 3. Depressing the foot pedal in either Fwd or Rev will move the 5K Ohm (R1) potentiometer shaft off its centered balanced (neutral) setting of approximately 2500 Ohms. With this pot shaft movement the pot's resistance value changes which generates a variable voltage signal (0-5 volts). These control board voltage input signals are what energizes the Fwd & Rev directional relays, which selects the motor polarity and what also manages switches the battery voltage On and Off (\*\*PWM) that varies the motor speed.

\*KSI: Key Switch Input

\*\*PWM: Pulse Width Modulation, also called "chopping" is a technique that switches battery voltage to the motor ON and OFF very quickly, thereby controlling the speed of the motor.

## DRIVE MODE SELECTION OPERATION OVERVIEW

The following is a list of the speed control parameters that can be adjusted using a Curtis hand held programmer:

There are four programmable speed limits on the BRX 700. These are transport speed, fast maintenance speed, maintenance/fast restore speed, and restore speed. For the maintenance and restore modes, the fast speed is selected by pressing the **speed select switch\*** on the control panel.

For reference purposes, the speed control parameters below are followed by a number from 1 to 4. These are used to indicate which parameters apply to which operating mode of the machine.

- (1) Transport mode [fastest] (scrub system off)
- (2) Fast Maintenance Mode (maintenance mode, speed select indicator = on)
- (3) Maintenance/Fast Restore Mode (maintenance mode, speed select indicator = off OR restore mode, speed select indicator = on)
- (4) Restore Mode [slowest] (restore mode, speed select indicator = off)

\***Speed Select Switch:** This switch will allow the operator to select a faster travel speed while the scrub system is enabled thereby allowing

TABLE #1

Value	Curtis Display Callout	Description	Factory Programmed Values	Approximate Travel Speed
3.0 sec	ACCEL MAX SPEED	Acceleration rate [time to go from stop to maximum speed in seconds]	1, 2	
3.0 sec	ACCEL MIN SPEED	Acceleration rate [time to go from stop to maximum speed in seconds]	3, 4	
3.0 sec	REVERSE ACCEL MAX	Reverse acceleration rate [time to go from stop to maximum speed in seconds]	1, 2	
3.0 sec	REVERSE ACCEL MIN	Reverse acceleration rate [time to go from stop to maximum speed in seconds]	3, 4	
100%	M1 MAX SPEED	Transport speed maximum limit [% of full throttle]	1	4.2 MPH
40%	M2 MAX SPEED	Fast maintenance mode speed limit [% of full throttle]	2	1.4 MPH
24%	M1 MIN SPEED	Maintenance/fast restore mode speed limit [% of full throttle]	3	.8 MPH
17%	M2 MIN SPEED	Restore mode speed limit [% of full throttle]	4	.5 MPH
70%	M1 REVERSE MAX SPEED	Reverse speed maximum limit [% of full throttle]	1	
30%	M2 REVERSE MAX SPEED	Reverse speed maximum limit [% of full throttle]	2	
24%	REVERSE MIN SPEED	Reverse speed maximum limit [% of full throttle]	3, 4	
OFF	THROTTLE AUTOCAL	Used for calibration of the throttle assembly		

extracting at a higher rate of speed. The speed select indicator will be green if a scrub mode has been selected and the faster scrub speed has been selected. It will be off otherwise.

# WHEEL DRIVE SYSTEM

## THE SPEED SELECTOR CIRCUIT INPUT

Note: The maximum and minimum machine drive wheel speed setting for the four drive modes can be changed by using the Curtis hand held programmer. Reference the Curtis programmer instructions found in the electrical system manual section to change programmable speed settings from their original factory specifications.

**FIGURE 1**

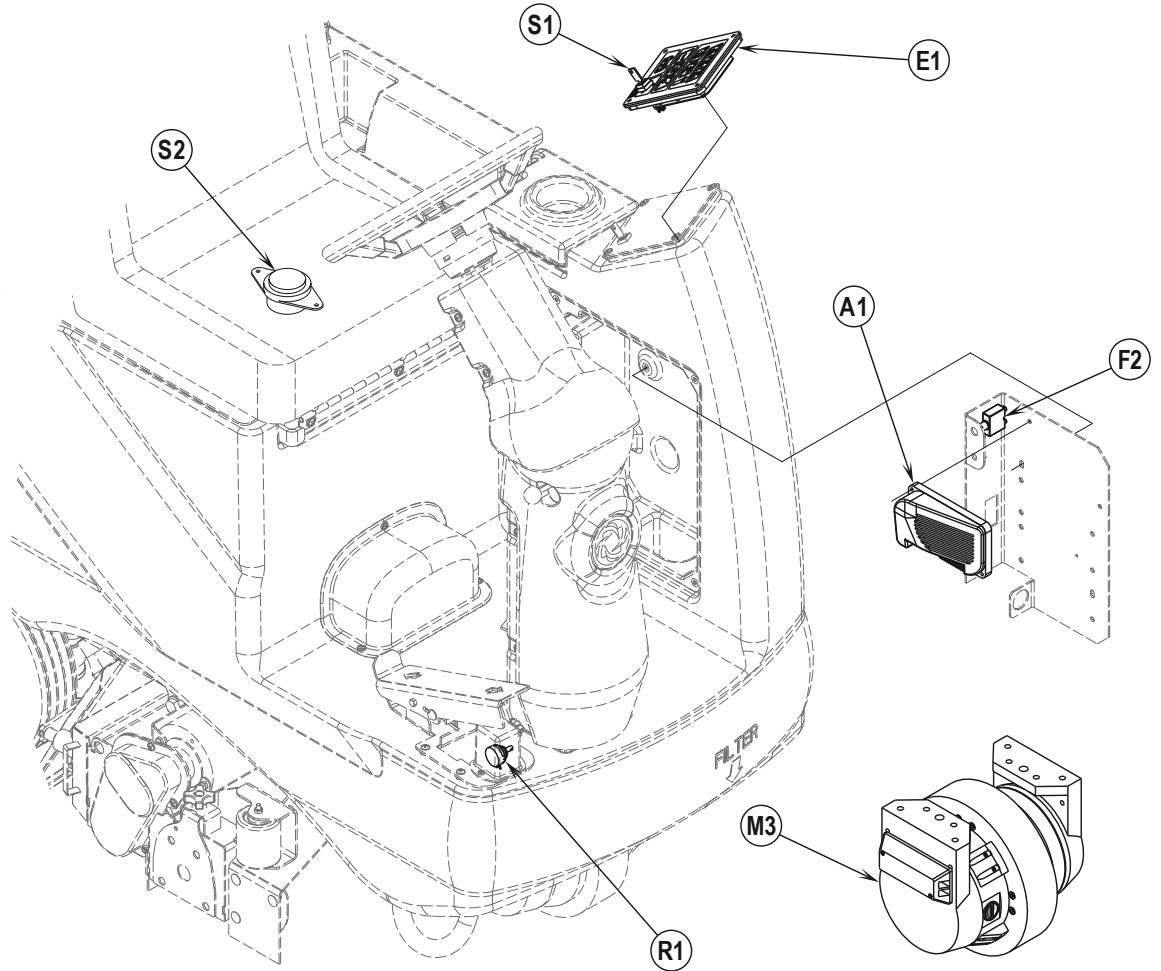

**FIGURE 2**

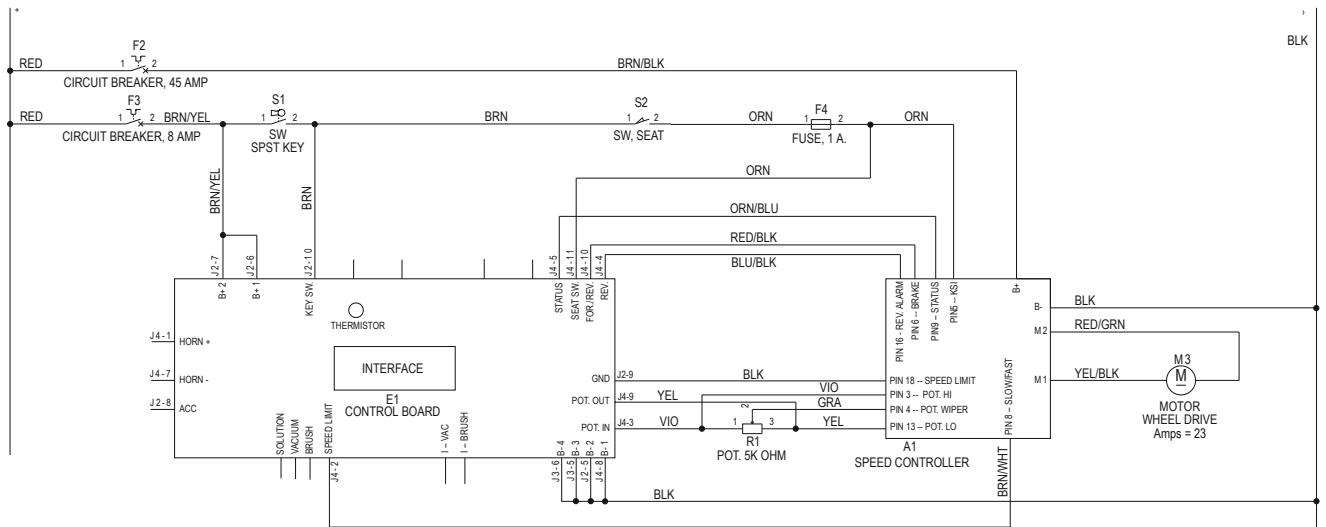

# WHEEL DRIVE SYSTEM

## FIGURE 3

R1 Voltage Values  
 0 – 2.5V Reverse  
 2.5 – 5V Forward

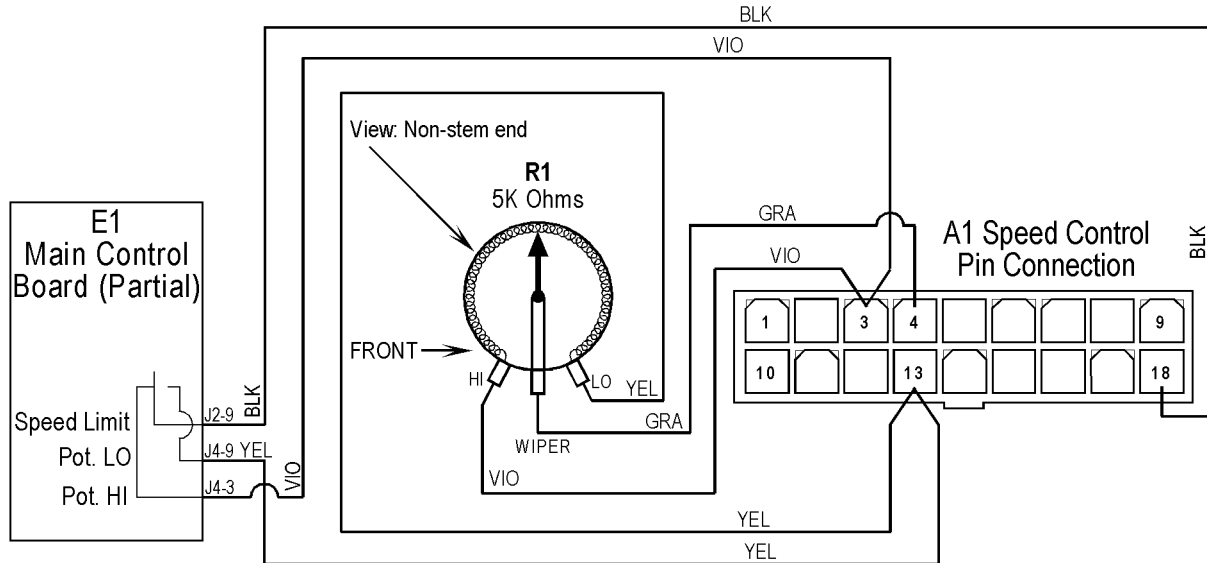

This drawing shows additional controller input circuit detail. The R1 pot is shown in the neutral position. Resistance is measured between pot low and pot wiper.

## FIGURE 4

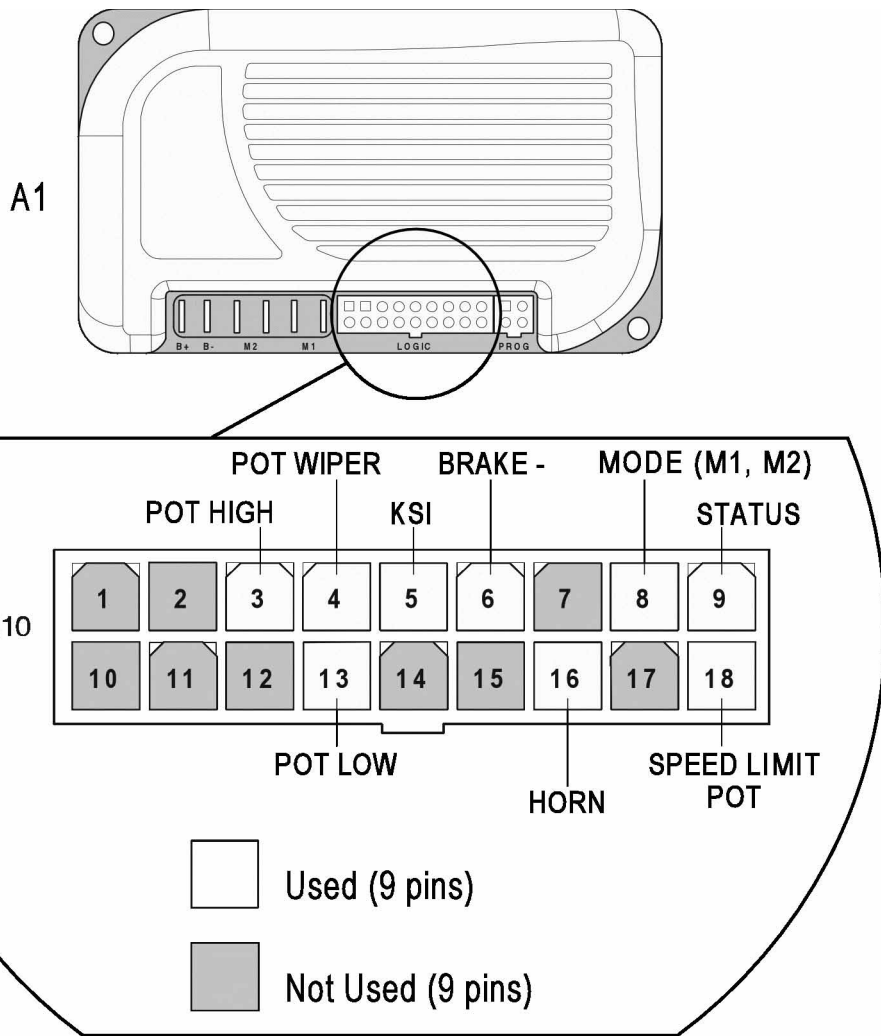

# WHEEL DRIVE SYSTEM

## Low Current A1 Speed Control Pin Key Detail

Pin #	Wire Color	Controller Pin Description & Function
1	–	Open not used
2	–	Open not used.
3	Vio	Throttle Pot R1 pot high input
4	Gra	Throttle Pot R1 pot wiper input
5	Orn	KSI (key switch input): Battery (+) powers up controller logic circuits.
6	Red/Blk	Auxiliary Driver: Battery (-) output to main controller (E1) to turn on (activate) all auto scrub functions.
7	–	Open not used
8	Brn/Wht	Mode Select 1: Drive motor scrub speed input, battery (+) from the (E1) Main Controller.
9	Orn/Blu	Status Fault: Speed controller fault output to main control panel fault indicator light (accessory wand)
10	–	Open not used
11	–	Open not used
12	–	Open not used
13	Yel	Throttle Pot R1 pot low input
14	–	Open not used
15	–	Open not used
16	Blu/Blk	Rev/Alarm Driver output Battery (-) commands turns off solution, raises scrub deck & sounds back-up alarm
17	–	Open not used
18	Blk	Speed limit pot input connection (reference <i>Table 1</i> ) Transport and Fast-Maintenance – tied to Pot HIGH Maintenance, Fast-Restoration and Restoration – tied to Pot LOW

## WHEEL DRIVE TROUBLESHOOTING GUIDE

Problem	Possible Cause
<ul style="list-style-type: none"> <li>Wheel drive motor will not run in forward and reverse.</li> </ul>	<ul style="list-style-type: none"> <li>Batteries need charging (low battery voltage, recharge batteries)</li> <li>Wheel Drive Motor Circuit Breaker (<b>F2</b>) tripped (reset 45A circuit breaker)</li> <li>Control Circuit Circuit Breaker (<b>F4</b>) tripped (reset circuit breaker)</li> <li>Parking Brake (<b>6</b>) set (release parking brake)</li> <li>Emergency Stop Switch (<b>13</b>) tripped (pull red knob to reset)</li> <li>Safety Switch (<b>S2</b>) in seat not closed (check seat switch)</li> <li>Defective Wheel Drive Motor (replace motor) *</li> <li>Defective Throttle Potentiometer (<b>R1</b>) (replace) *</li> </ul>
<ul style="list-style-type: none"> <li>Wheel drive in one direction only, loss of either forward or reverse.</li> </ul>	<ul style="list-style-type: none"> <li>Test the Fwd &amp; Rev (<b>R1</b>) wiring outputs (pins 3, 4 &amp; 13) at the speed control for an open. Repair wiring or replace the R1 throttle pot.</li> <li>Controller can't change electrical polarity to wheel motor replace the (<b>A1</b>) speed control.</li> </ul>
<ul style="list-style-type: none"> <li>Hourmeter/status display shows an error 03 fault code.</li> </ul>	<ul style="list-style-type: none"> <li>Speed controller has sensed an operation error code fault. (see the <i>Status LED Fault Codes (Table 2)</i> in the Electrical System)</li> </ul>

\* = See *Curtis Speed Control Troubleshooting* Section.

# WHEEL DRIVE SYSTEM

## STEERING SPINDLE AND WHEEL DRIVE MOTOR ASSEMBLY REMOVAL

### ⚠ WARNING!

Turn the main key switch (J) to the off position and disconnect the battery pack by pushing in the emergency disconnect lever (13). Next block both rear wheels so machine can't roll.

- 1 See Figures 6 & 7. Remove the brake foot pedal (A) secured by the (2) screws (D) that fasten the pedal mount bracket to the chassis allowing access to the spindle retainer nut.
- 2 Pull out the brake rod (E) and use a 1-7/16" socket to remove the large spindle nut (F) from its shaft.
- 3 From underneath the front of the machine loosen the (4) (G) screws and push the lower steering column to the rear of the machine. This is done to separate the chain (H) from the steer sprocket (I). **Service Note:** Use a 5/8" socket with 3" extension to remove screws and also correctly position the large hole in the steer plate (J) in order to access the far back left screw.
- 4 On the right side of the drive motor remove the motor wiring cover and observe the (2) wires (red/green & yellow/black) attached to the motor terminal connections for reassembling. Then remove the wires using a 13mm wrench.
- 5 Remove the (1) socket head cap screw (use a 3mm hex wrench) that retains the motor wiring harness P-clamp, then pull wiring to the rear of the machine.

### ⚠ WARNING!

Never work under machine without safety stands or blocking to support the machine.

- 6 Safely jack up or lift the front of the machine to a height of approximately 16 inches (41 cm) to remove the wheel motor spindle assembly. Place wood blocking under both front frame legs to support machine when removing the wheel / spindle assembly. **Service Note:** Be careful not to damage the threads and bearing surfaces when guiding the spindle shaft down through the frame opening.
- 7 Inspect bearings and shaft seal and replace as needed.
- 8 To remove the steer spindle weldment (K) you must remove the steer plate (J) (with splash fender) held by (4) (L) flat head socket screws (use a 5 mm hex wrench) then separate the brake return spring and lay these removed parts to the side. Next remove the (4) item (M) flat head socket screws (55mm length) then finish removing the spindle weldment.
- 9 See the "Drive Tire Removal" section for further disassembly steps.
- 10 Re-assemble in reverse order and tighten the spindle shaft nut (F) to 20ft/lbs (27 Nm) to eliminate any bearing play.

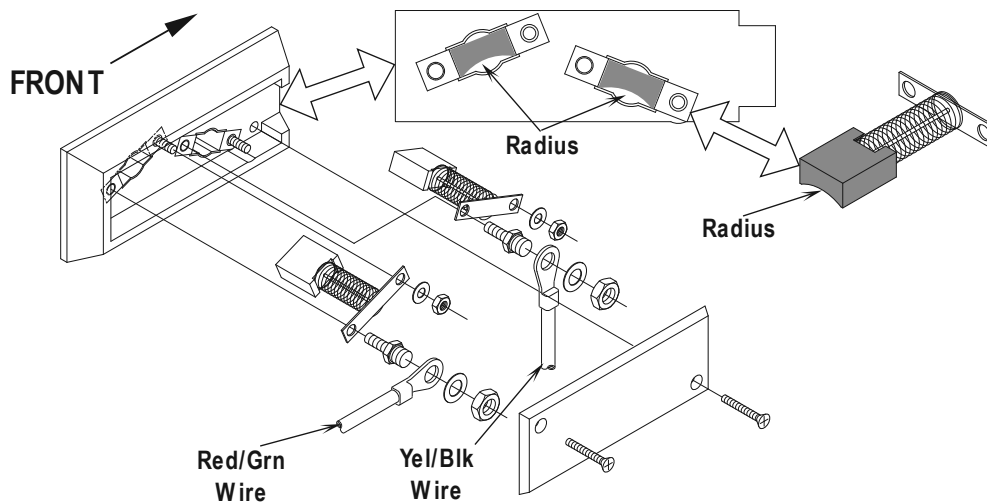

FIGURE 5

## DRIVE TIRE REMOVAL

- 1 Follow the steps 1-8 in the "Steer Spindle and Wheel Drive Motor Assembly Removal" section.
- 2 See Figure 6. Remove the Retaining Ring (O) from the brake Pivot Pin (N). Then slide the pin out of the brake lever and support mount being careful not to lose the washer which goes between them.
- 3 Carefully separate (tap off) the motor end bell housing (P) from the main motor case. **Service Tip:** To remove the housing use a brass drift or piece of hard wood and strike the end bell edge evenly at points 120 degrees apart to slowly work it from the motor bearing.
- 4 Using a 5mm hex key wrench remove the (8) socket cap screws (Q) that secure the drive tire (R) to the motor drive hub and complete the tire removal.
- 5 Install a new drive tire and tighten (torque) the (8) socket cap screws (Q) to 12 Ft/Lbs (16.2 N/M). **Service Tip:** Apply a small amount of Loctite 242 to all the cap screws to prevent the fasteners from backing out.
- 6 Re-assemble in reverse order following all the steps outlined in the steer spindle and drive motor removal section.

# WHEEL DRIVE SYSTEM

## FIGURE 6

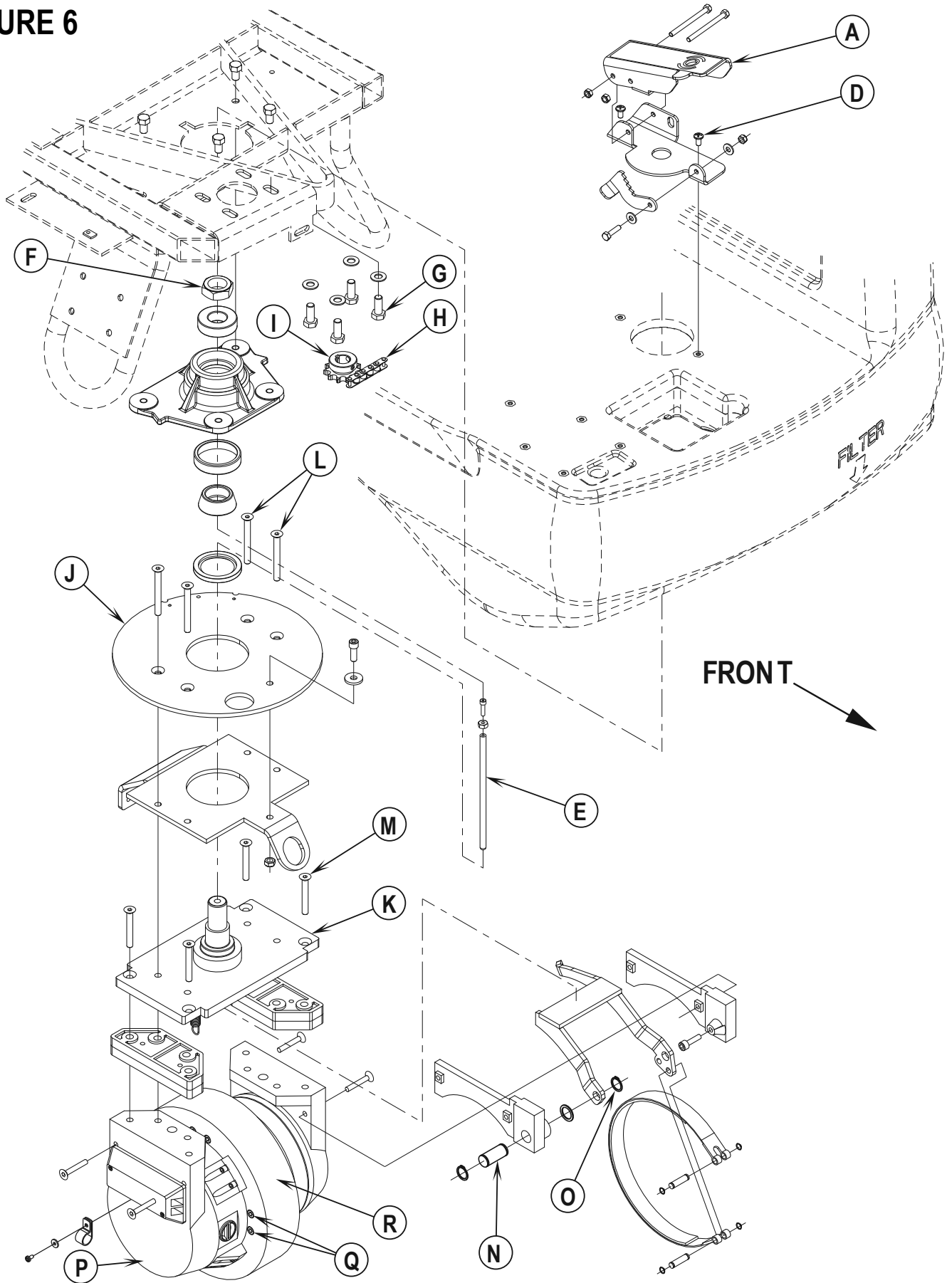

# WHEEL DRIVE SYSTEM

## BRAKE ADJUSTMENT

- 1 See Figure 7. Adjust the (E) brake rod's length to eliminate any foot pedal free play (space between the pedal and rod end) when the pedal is at rest (not being engaged).
- 2 The rod length can be changed by loosening the jam nut (S) and threading the adjustment screw (T) In or Out.
- 3 To access the brake rod remove the front pedal mounting hardware items (B & C), then swing (pivot) the pedal backwards out of the way.
- 4 Use a 3/8" wrench and 1/8" hex key wrench to both loosen and tighten the rods adjustable hardware.
- 5 Note: Also check the brake bands brake lining for wear when excessive pedal travel can not be eliminated through adjustments. Service by replacing worn brake band and readjust and test for proper brake operation.

**FIGURE 7**

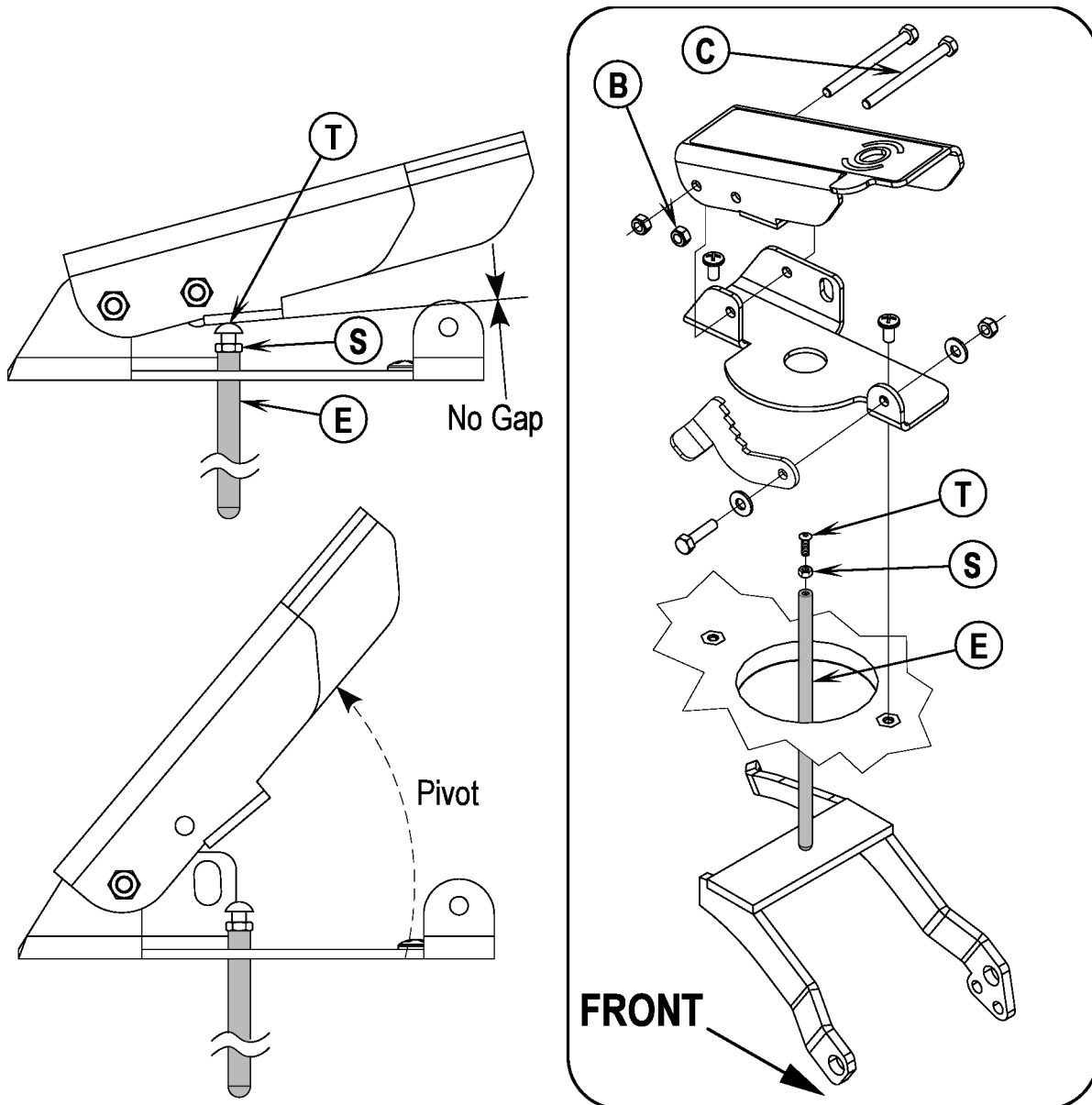

## DRIVE WHEEL BRAKE STRAP REPLACEMENT

### **⚠ WARNING!**

Turn the key switch to the off position and then disconnect the battery pack by activating the emergency stop switch/battery disconnect lever (13).

- 1 See Figure 8. Remove from the brake band (U) the front lower outside retainer ring (V) (external type). **Service Tip:** Use retaining pliers (tip size .038 inches/1 mm) to prevent damage when removing all retainer rings. Then drive out the pin (W) from the brake band end.
- 2 Remove the socket head cap screw (X) (use a 6mm hex key wrench) that fastens the left side brake lever to the support mount (Y). Next separate the brake lever from the mount bracket and pull it down to access the back retaining ring and remove it at this time.
- 3 Remove the second mount pin then carefully expand the brake band enough to clear the drive wheel brake drum and remove from the machine.
- 4 To install the brake band follow the above steps in reverse order. See the "Brake Adjustment" section in this manual and adjust the brake pedal free play and test the brake system for proper operation.

### **⚠ CAUTION!**

Test-drive the machine and check for positive brake pedal and parking brake functions.

## WHEEL DRIVE MOTOR CARBON BRUSH INSPECTION (500 HOURS)

- See Figure 8. There are (6) carbon brush assemblies, (4) of them are located equally spaced on the outside diameter of motor end bell cover. Remove the inspection caps (Z) by carefully twisting the cap a 1/8 of a turn counterclockwise. The other (2) brushes are located behind the motor wiring terminal cover (AA). Remove the black cover and terminal mounting hardware. **Note:** The (4) motor commutator brushes are secured with two slotted screws.
- A new carbon brush measures 20mm (.780 inches) in length. Replace the brushes when worn to a length less than 9.5mm (.375 inches).

**FIGURE 8**

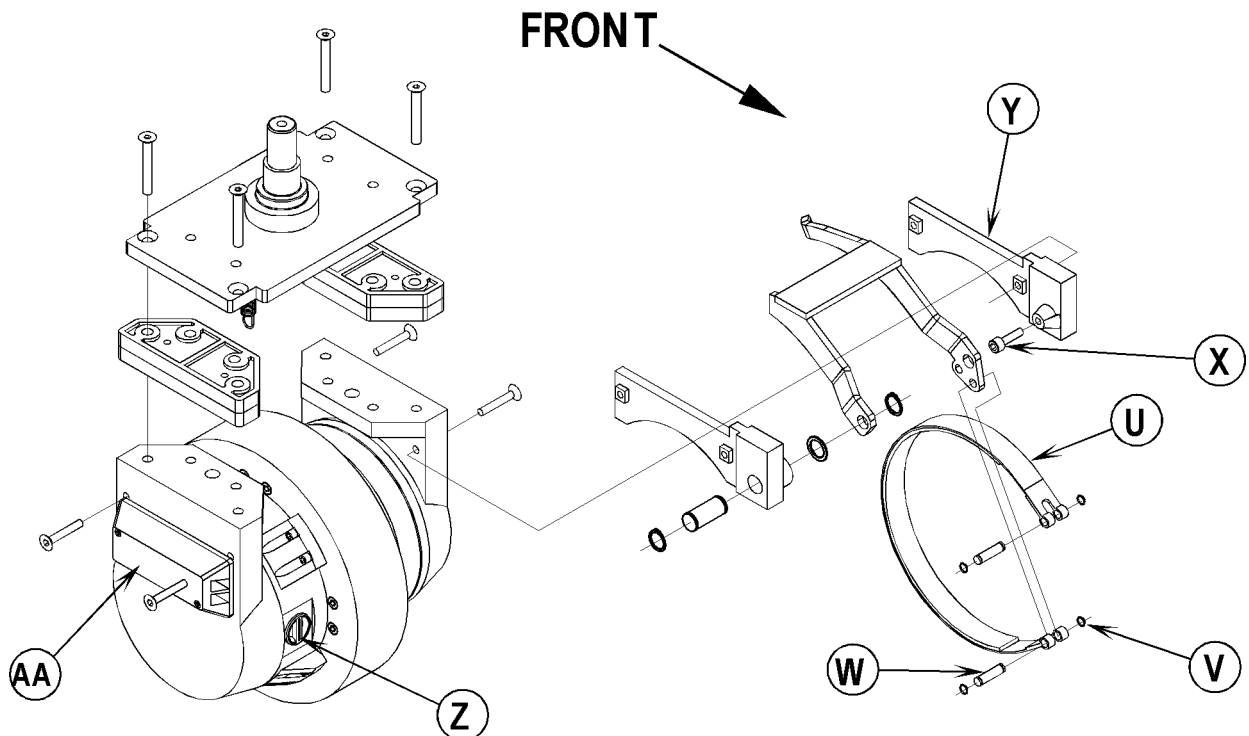

# WHEEL DRIVE SYSTEM

## POTENTIOMETER REMOVAL AND TESTING

### ⚠ WARNING!

Disconnect the machine's battery pack connector (13) before servicing.

#### Potentiometer Removal

- 1 See Figure 9. Remove the (5) Screws (AB) securing the drive pedal mount assembly to the chassis then carefully lift the pedal assembly up and lay it on its side.
- 2 Observe the (3) wires connected to the Drive Pedal Potentiometer (pot) (AC) and also the single GRN/YEL throttle ground wire (AD), note the proper wire colors and their terminal connections for re-assembly. Then disconnect wiring and remove the pedal mount assembly from the machine.
- 3 Remove the Link Rod (AE) from the Pedal (AF). **Note:** Be careful not to lose the link rod mounting hardware items (AG).
- 4 Loosen the Nut (AH) and Screw (AI) at the drive pedal Throttle Lever (AJ). Then pry the lever off from the end of the item (AC) potentiometer shaft. Next remove the pot from the Mount Housing (AK).

#### Testing the Potentiometer

Note: The pot doesn't have to be removed from the housing to test.

- 1 Test the potentiometer using an Ohmmeter (the pot specification is 5K Ohms).
- 2 Connect the meter leads to each of the outside connections on the potentiometer. The meter should read approximately 5000 Ohms (plus or minus 500 Ohms).
- 3 Next, move one of the test leads to the middle connection and turn the stem in both directions. The range of the readings should be approximately 0-5000 Ohms or 5000-0 Ohms increasing and decreasing through its full range.
- 4 If you do not get these readings replace the potentiometer.

FIGURE 9

FRONT

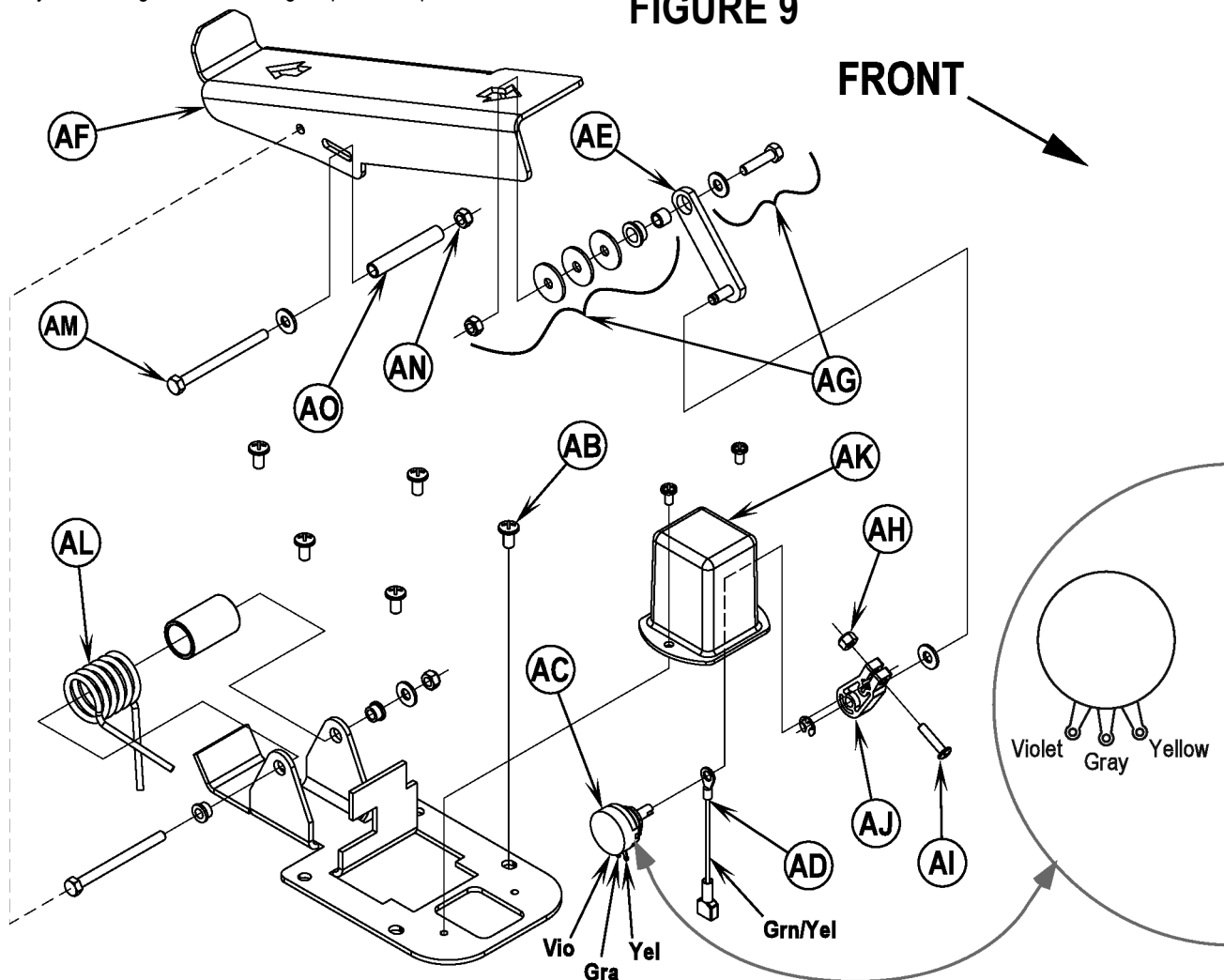

## POTENTIOMETER INSTALLATION AND ADJUSTMENT

### **⚠ WARNING!**

The adjustment of the potentiometer is to set the drive pedal for a neutral drive motor operation. If the pot is not adjusted properly, the machine will creep in either FWD or REV.

- 1 See Figure 9. Install the pot into the Mount Housing (AK) and tighten the attachment nut.
- 2 Connect together loosely both the Link Rod (AE) to the Pedal (AF), and the Throttle Lever (AJ) to the potentiometer input shaft. Then tighten only the Link Rod (AE) pedal mounting Hardware (AG). Note: Check the movement of the Foot Pedal (AF) it must move freely in both Fwd and Rev.
- 3 See Figure 9 inset. Attach test leads from a volt/ohm meter (set meter on 0x100 scale) to the YEL and VIO wire connection points on the potentiometer to check it's total resistance (example 4800 Ohms).
- 4 Next connect the ohmmeter test leads to the GRA and VIO potentiometer connection points. Then using a small screwdriver, turn the shaft end on the pot to half the total resistance previously measured. Example: 4800 Ohms divided by 2 = 2400 Ohms. Then without turning the shaft, tighten the Screw (AI) and Nut (AH) to secure the setting at the Throttle Lever (AJ).
- 5 Follow steps 1-2 in reverse order (see Potentiometer Removal steps) to finish the installation. Then test-drive the machine for proper speed and FWD/REV directional control.

## DRIVE PEDAL NEUTRAL ADJUSTMENT & PEDAL REPLACEMENT

If the drive pedal has been removed or replaced, the neutral position for the pedal will have to be set. Follow the steps below to accomplish this.

### **⚠ WARNING!**

Disconnect the machine's battery pack connector (13) before servicing.

- Note: See Figures 9 & 10. Before making any adjustments, inspect the Torsion Spring (AL) for defects and the correct positions of both spring ends (repair or replace).

To Adjust Pedal Spring

- 1 Loosen the Screw (AM) & Nut (AN), the screw with bushing is positioned between both Fwd & Rev torsion spring ends. Its placement controls the needed pre-load pressure to eliminate excessive pedal free-play and a balanced spring rate to return the pedal to a centered (neutral) position.
- 2 Push the screw back into the pedal frame slot to increase spring tension and eliminate pedal free play. Then tighten the screw & nut being careful not to pull on the linkage connection to the pot shaft and disturb (move) its neutral setting.

To Replace Pedal or Spring

- 3 Position the torsion spring ends (A & B) as shown. This is with the Bushing (AO) and Screw (AM) not installed.
- 4 Place the bushing inside the pedal channel pilot it into position using a scratch awl or a pin punch.
- 5 Then pivot (press) the pedal and insert the screw from the opposite side pushing the guide tool out.
- 6 Use a screwdriver to tap and pry the bushing back in the pedal slot to increase spring tension
- 7 Work the bushing back & forth on both sides of the pedal to obtain equal spacing. Then tighten the screw and nut.
- 8 A correctly adjusted drive pedal will have minimal amount of free-play when selecting a drive direction.
- 9 Reconnect the batteries and test the machine to make sure it does not "creep" forward or reverse when the pedal returns to neutral.
- 10 **Service Tip:** Also confirm the Hourmeter/Status Display (G) is free of the error code 03 (drive system fault). If error 03 is shown the throttle is not set properly for the potentiometer and or drive pedal neutral position. Check both again and readjust.

**FIGURE 10**

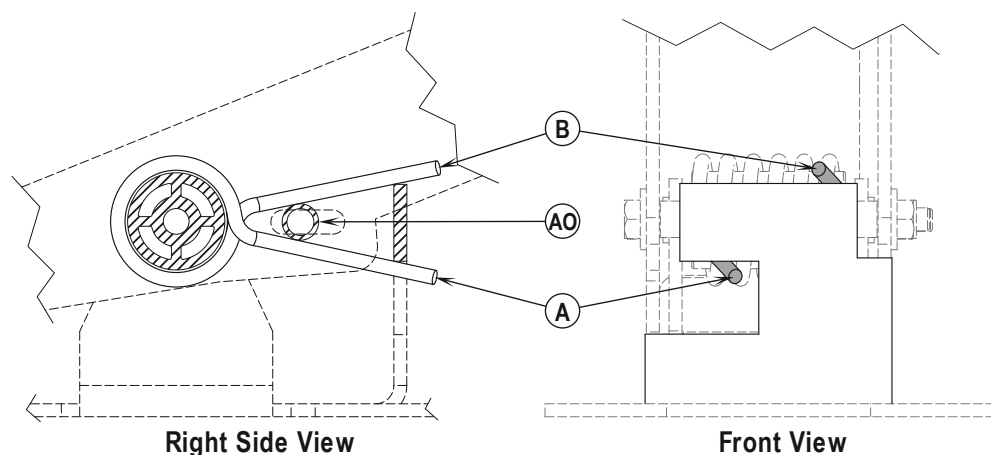

# SCRUB BRUSH SYSTEM

## FUNCTIONAL OVERVIEW

### • Cylindrical Brush System Overview

See Figure 6. The BRX 700 uses two cylindrical brushes that counter rotate to sweep up light debris and scrub at the same time. Each scrub brush is powered on opposing ends by 3/4 HP permanent magnet motors attached to separate poly-V belt/pulley drives.

### • General Brush Overview

On all models the scrub deck platform is raised & lowered automatically by a vertically mounted electric lift actuator motor (M1). The operation of the machine's scrub functions are activated when the operator selects (presses) either the scrub maintenance or restoration (mode) panel buttons. The scrub brush pressure ranges (light through heavy) are programmable allowing the operator the choice to vary the scrubbing effort (pressure) for numerous carpet cleaning requirements. Note: See *the Main Control Board Special Program Options* section in this manual for more detailed operation and instructions to change scrub pressure settings.

See Figure 1. The machine's main scrub system input and output operating functions are regulated (managed) by the combined membrane switch display panel and main control board E1. The major scrub system functions are...

### • Scrub Brush Motor Run Function

To turn On (energize) the K1 brush motor solenoid either the scrub pressure maintenance or restoration buttons (location E1 panel) must be pressed and the (foot activated) drive pedal moved off its neutral position triggering an output from the R1 directional throttle potentiometer. These two-operator functions deliver the required E1 control board and A1 speed control circuit inputs.

Detailed Explanation of the scrub motor function

A closed E1 membrane panel switch input (either maintenance or restoration) enables the E1 microprocessor automatic functions for the brush lift, **brush solenoid**, solution solenoid and vacuum solenoid. The next step is the movement of the foot pedal for the needed R1 throttle output to the A1 speed controller, which causes either FWD or REV motor action. At the moment of R1 throttle input the A1 controller closes an internal coil driver and outputs a POS. 36V signal from pin #6 (wire color Red/Blk) to the E1 J4-10 connection. This positive input signal causes the controller to output a NEG. 36V signal from J2 pin #1 (wire Wht/Red) and completes the K1 negative solenoid coil pulling in the high current contactor making the brush motor(s) turn on (run). Note: The positive K1 control circuit voltage is supplied by the E1 board's J2 pin #8 wire (Wht/Brn).

### • Scrub Brush Actuator Lift Motor Function

The control board outputs activate (raise and lower) the scrub-deck for installing, removing and controlling the scrub brushes' selected pressure limits (current load). The negative (-) brush motor wire is specially designed so that it has a known (specified) resistance value. As brush motor current passes through the negative wire that is, in effect, a low value resistor, a small voltage drop is measured across it which is proportional to the motor current. This current measurement shunt circuit is made up of two small diameter sense wires (J4-12 Yel/Vio & J4-8 Blk) and are the inputs used by the control board to calculate the exact current level of the scrub brush motor(s). Any temperature change to the large (Neg.) motor wire affects its resistance so the circuit temperature is sensed by a thermistor (\*) built into the control board. This allows the controller to provide a level of error correction for the temperature resistance changes. When the controller senses a current draw out of the desired range (selected pressure limit) it automatically turns on the M1 actuator motor to raise or lower the scrub deck. This process is on-going in maintaining the operator's selected scrub motor current load (setting #) to sustain the desired brush working pressure.

### • Low Voltage Cut-Out Function

The purpose of the low voltage cutout function is to help prolong battery life. The main control board E1 is programmed to monitor the machine's battery pack voltage to prevent over discharging of the batteries. The brush motors, brush lift actuator and solution solenoid valve will turn OFF automatically and cease to function when the batteries are discharged to the selected cutout level. The cutout level is adjustable between two settings. The standard battery type (wet cell) is 31.5 volts (1.75 volts per cell) and maintenance free battery (gel) is 33 volts (1.83 volts per cell). Note: See the Electrical System for instruction in selecting (setting) the two different thresholds.

\* Thermistor: A special semiconductor resistor whose resistance value varies with temperature.

Note: See the "Know Your Machine" section in this manual for a complete explanation for all scrub system operational modes.

# SCRUB BRUSH SYSTEM

## SCRUB BRUSH SYSTEM TROUBLESHOOTING

On all models the scrub system's major electrical components are monitored by the main controller (E1) to detect any system function failures (error codes). The system components covered are the brush motor(s) (M7 & M8), brush solenoid (K1) and brush lift actuator motor (M1). Detected error codes from the main controller are displayed on the hour meter LED display (G) as they occur. Note: Reference the *Main Control Board Troubleshooting Guide* in the Electrical System of this manual for specific fault descriptions and service repair actions.

**FIGURE 1**

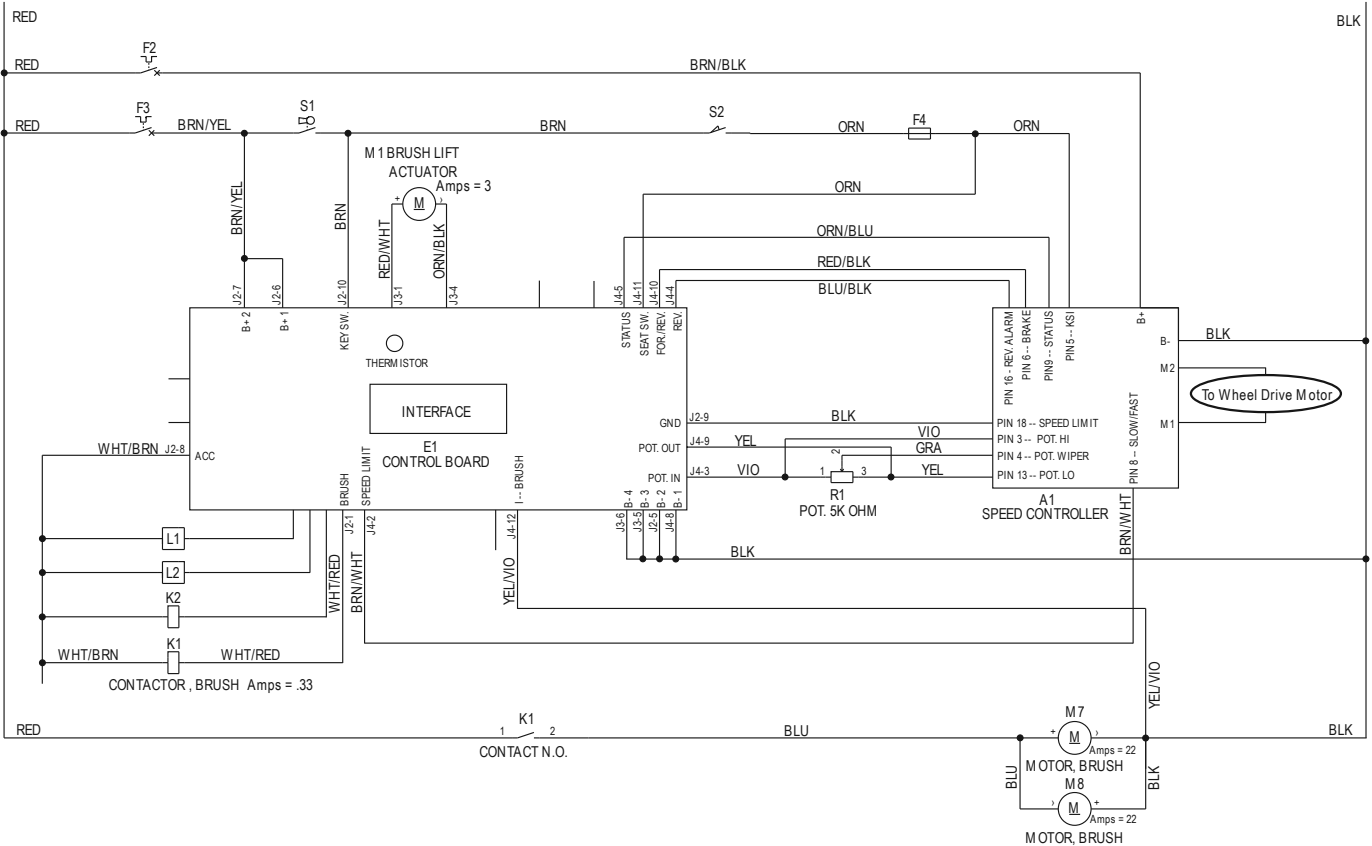

# SCRUB BRUSH SYSTEM

## SCRUB DECK REMOVAL

- 1 See Figure 2. Pull off the two vacuum recovery Hoses (A) from the Vacuum Shoes (B).
- 2 Remove both vacuum pickup shoes by removing the two black Knobs (C) then lift up and pull out the retainer Bars (D) to separate them from the scrub deck pins. Next pull back the pickup shoe from the deck bearing mounts to complete their removal.
- 3 Remove the sweep debris Hopper (E) from the scrub deck.
- 4 Lower the scrub deck with the brush(s) installed. **Attention:** Don't turn the key switch off until after disconnecting the battery pack by pushing in (activating) the Battery Disconnect (13). This procedure is done to prevent the scrub deck from automatically raising when the key is turned off.
- 5 Remove the wing Nut (F) that secures the solution nozzle tree Assembly (G) to the scrub deck then pull the assembly with hoses to the side.
- 6 Unplug the brush motor wiring Harness (H) (under left side of machine).
- 7 Remove the lower hitch Pin (I) that secures the brush deck lift actuator to the scrub deck.
- 8 Remove the two Hitch Pins (J) that attach the scrub deck to the machine chassis linkage arm weldment.
- 9 From the right side of the machine swing the brush deck actuator housing forward to clear the deck mount bracket. Then carefully maneuver the deck out from under the machine to complete its removal. Service Note: It is important that the disconnected deck actuator motor is not run. This precaution will prevent the actuator drive nut from being moved from its set specification.
- 10 To install the scrub deck follow the above steps in reverse order.

FIGURE 2

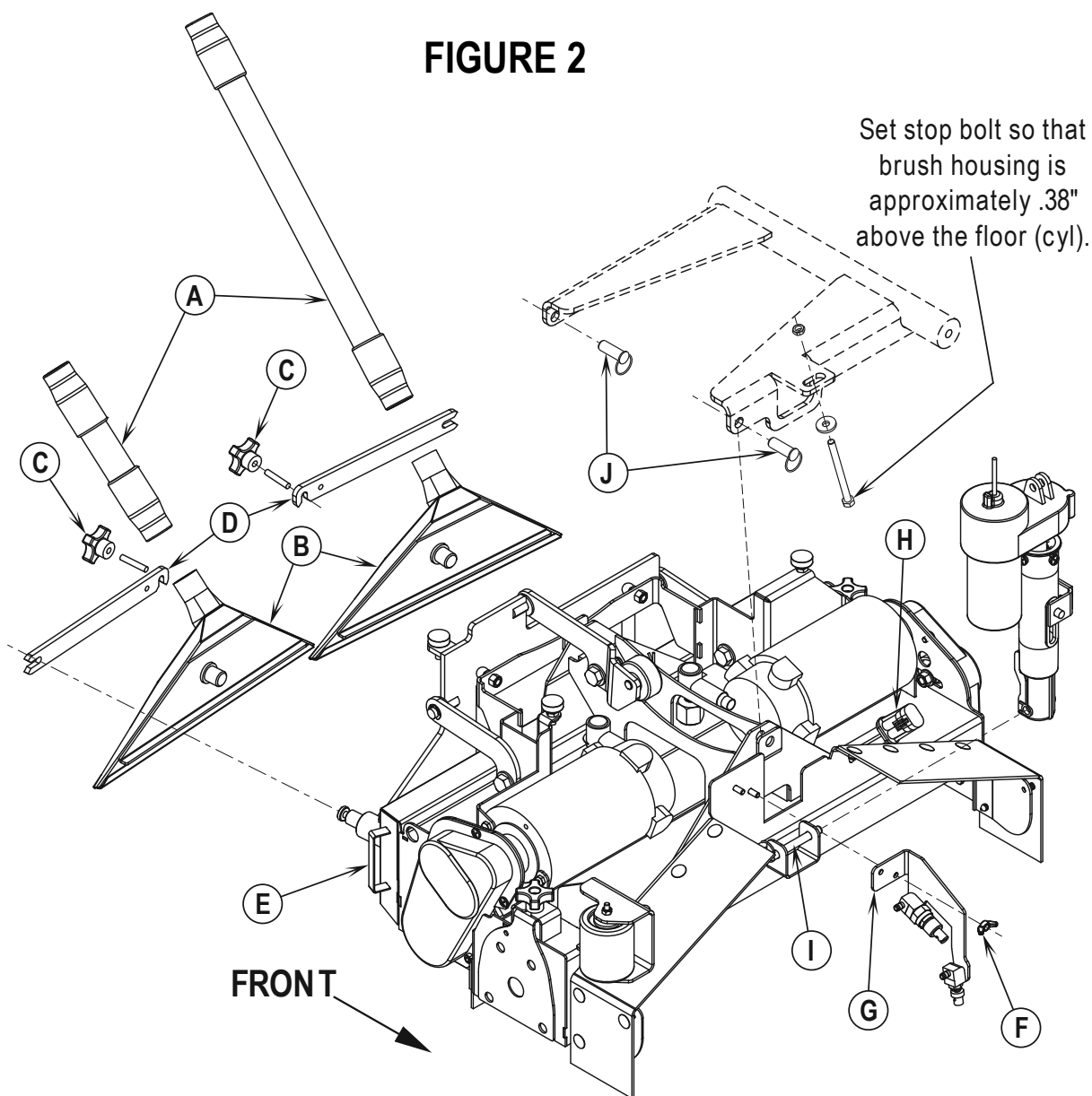

## BRUSH DECK ACTUATOR REMOVAL

- 1 Lower the scrub deck with the scrub brushes installed. Don't turn the key switch off until disconnecting the battery pack by using the emergency disconnect lever (13). This procedure is done to prevent the scrub deck from automatically raising when the key is turned off.
- 2 See Figure 3. From underneath the machine remove the clevis Mount Pin (K) that secures the lower actuator housing to the scrub deck mount bracket.
- 3 Disconnect the brush lift motor wire harness at the motor.
- 4 Remove the top actuator (inspection) Cover (L) held with (3) screws. Cover location operator's compartment below front of seat.
- 5 Remove the Hairpin (M) then slide the upper Mount Pin (N) out from the chassis mount bracket.
- 6 Remove the complete actuator lift motor assembly from underneath the machine. **Note:** Do not turn or reposition the drive nut on the actuator shaft, mark if needed.
- 7 **Important:** After removing the actuator motor and before replacing a new motor or drive nut the IN & OUT limit switches must be set (or checked) to their correct dimensional specifications (see the electrical section for the Actuator Drive Nut Adjustment instructions).
- 8 To disassemble the Drive Nut (O) from the actuator shaft, remove the (2) Screws (P) and separate both Retainers (Q & R) from the Spring Housing (S).
- 9 Remove the (4) spring housing retainer Screws (T) and slide the spring housing and (long) Compression Spring (U) from the actuator shaft. Next spin the drive nut off the shaft and save the top (short) Compression Spring (V). **Note:** See the Actuator Drive Nut Adjustment section in this manual to properly install a new drive nut.
- 10 After adjusting the drive nut follow steps 1-9 in reverse order to re-install the scrub deck lift motor in the machine.

**Service Tip:** Wrap a small amount of tape around the spring housing to prevent it from spinning out of adjustment.

**Service Tip:** Shown in the Electrical System is the actuator power cord adapter PN 56407502 and instructions for use. This tool can be used to help position (raise or lower) the drive nut housing for ease in the actuator mounting pin installations. An additional method to control the output to the brush lift actuator for installation and removal is to read the instructions in the *Service Test Mode* section for the special output control of the Maintenance Mode Switch (D) (See Electrical System for steps to enter the *Service Test Mode*).

**FIGURE 3**

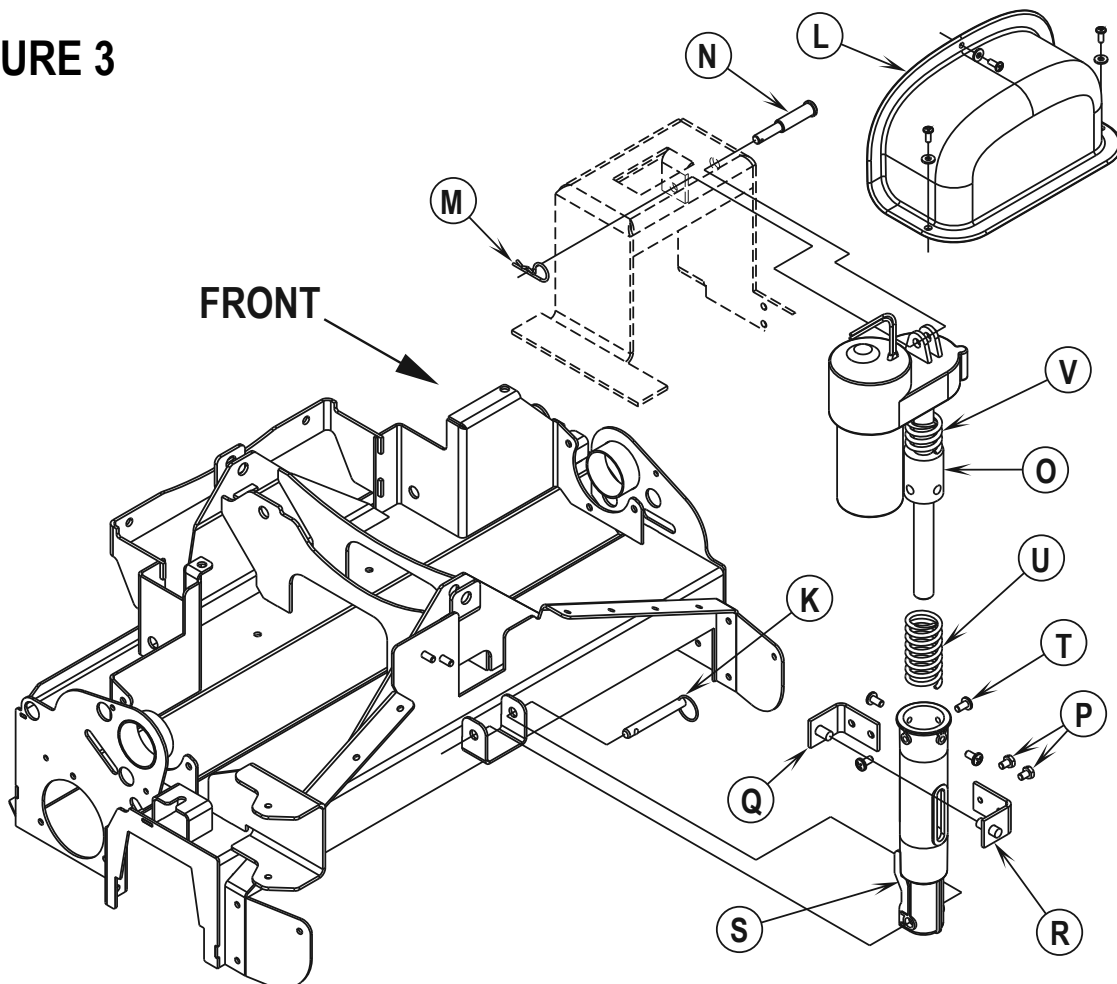

# SCRUB BRUSH SYSTEM

## SCRUB BRUSH MOTOR(S) REMOVAL

- 1 See Figure 4. Remove the Belt Guards (W) (4 screws per side). With an operator in the driver's seat with the key switch ON and the maintenance mode scrub function selected press the drive pedal to start the scrub brushes and observe which brush motor needs to be removed.

### **⚠ WARNING!**

Disconnect the battery pack by activating the emergency stop switch/battery disconnect lever (13) before servicing.

- 3 Next loosen the scrub brush belt tension Hex screw in the center of the Belt Idler (X) (using 5/8" & 11/16" wrenches).
- 4 Remove the wiring at both the Pos. & Neg. brush motor terminal studs and note the correct wiring connections (for reinstallation). Then remove the (3) Screws (Y) and lift the motor out from the scrub deck.
- 5 Reassemble in reverse order and adjust the belt tension to 3/4 - 7/8 inches (19-22 mm) as shown in Figure 5. Note: Install motors with wires pointing to the rear towards the plastic motor wiring standoffs.

## SCRUB BRUSH BELT REPLACEMENT

### **⚠ WARNING!**

Disconnect the battery pack by activating the emergency stop switch/battery disconnect lever (13) before servicing.

- 1 See Figure 4. Remove the belt guard(s) (W) (4 screws each).
- 2 **Important Service Tip:** The left and right side drive belts are not the same lengths they must be ordered individually (P.N. 56407465, left side & P.N. 56407466, right side). Note: Single brush machine uses P.N. 56407465.
- 3 Loosen the scrub brush belt tension hardware on the Belt Idler Pulley (X) (using a 5/8" & 11/16" wrench). Pull the idler wheel away from the backside of the belt and roll the belt off both the motor and brush pulleys. Then inspect for wear and replace as needed.
- 4 Re-install the drive belt and tension the belt as shown in Figure 5. Then install the belt guard, reconnect the battery pack and test the scrub system for proper operation.

\*Rotation of shaft from shaft end.

**FIGURE 4**

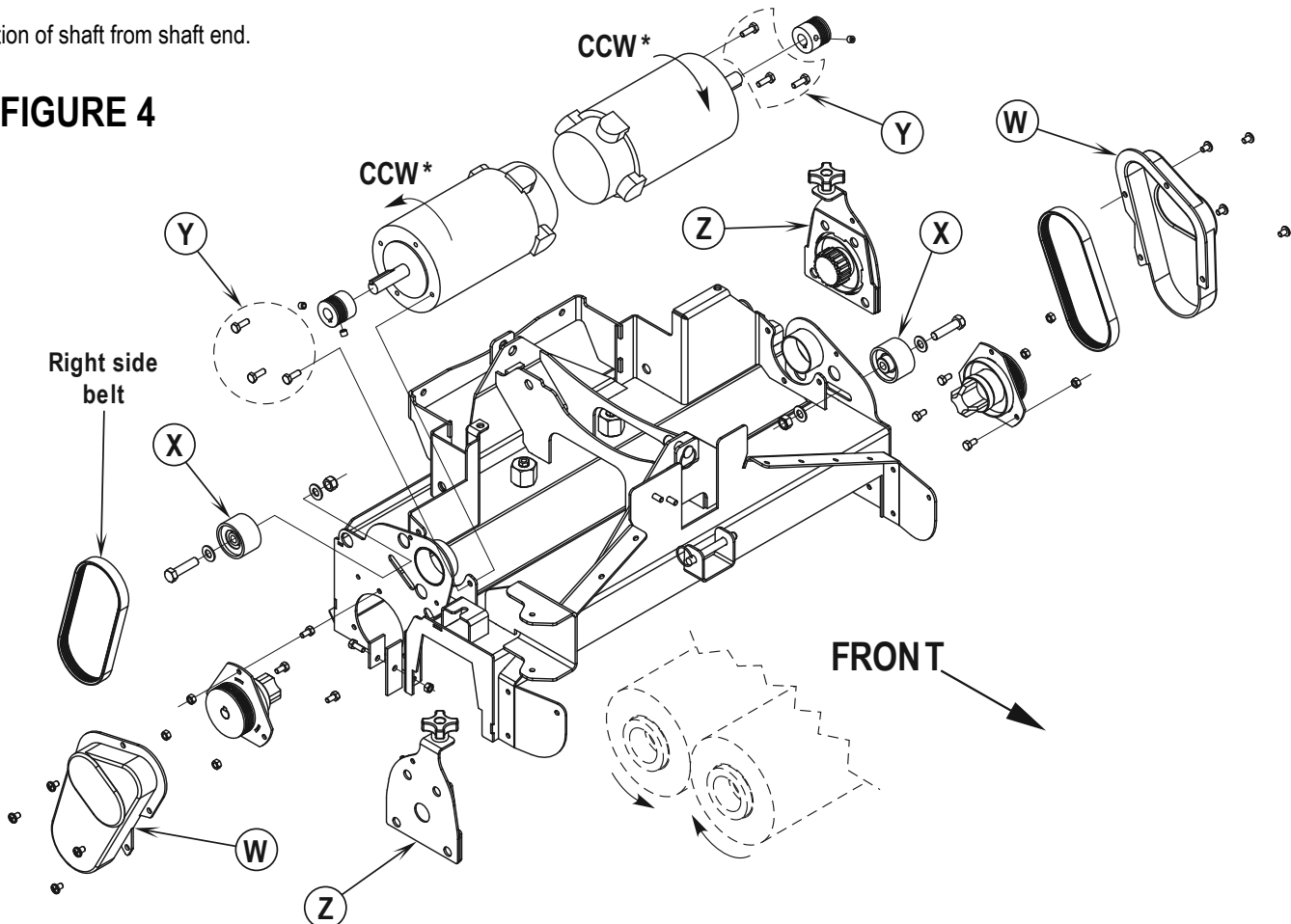

# SCRUB BRUSH SYSTEM

## SCRUB BRUSH SYSTEM MAINTENANCE

The scrubbing system must be serviced at regular intervals to maintain good scrubbing performance. Follow the maintenance steps listed below.

- 1 Rinse clean, built up debris from the debris hopper drain holes (daily).
- 2 Remove any string wrapped around the scrub brush, drive hub and idler hub (daily).
- 3 Clean spray nozzles attached to the front of the scrub deck (weekly).
- 4 Clean built up dirt from the inside of the scrub brush housing (weekly).
- 5 Remove both the scrub brushes and rotate, turn end for end (weekly). See *Scrub Brush Removal and Installation (Cyl)* section.
- 6 Inspect the scrub brush bristles for wear, the brushes should be replaced when the bristle length is 1 inch (26 mm) or less (monthly).

FIGURE 5

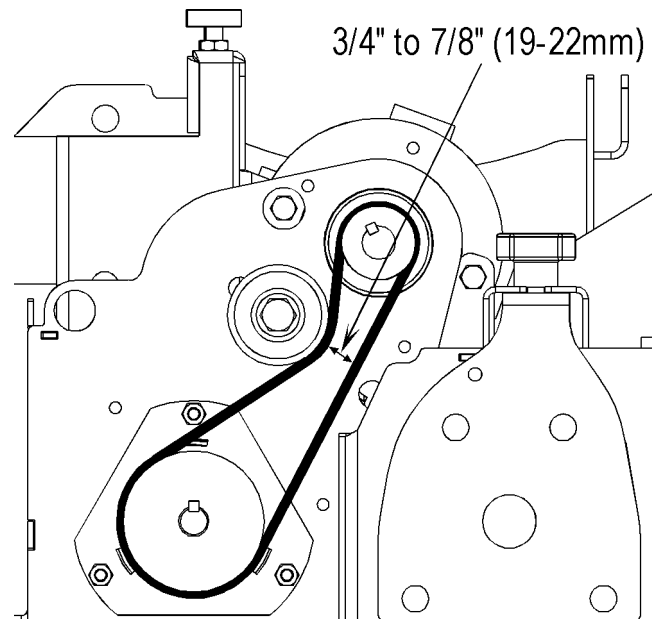

## SCRUB BRUSH REMOVAL AND INSTALLATION

- 1 Make sure the key switch is off and disconnect the battery pack before servicing.
- 2 See Figure 4. Loosen the black knobs (one on each side) that secure the removable bearing idler support Plate (Z) to the brush housing, then pull the plates down and out to remove. Grip the scrub brush and slide it out from the housing end.
- 3 To install the brush slide it into the housing, lift slightly, push and turn until it seats into the drive end assembly.
- 4 Re-install the idler end plate assemblies.

FIGURE 6

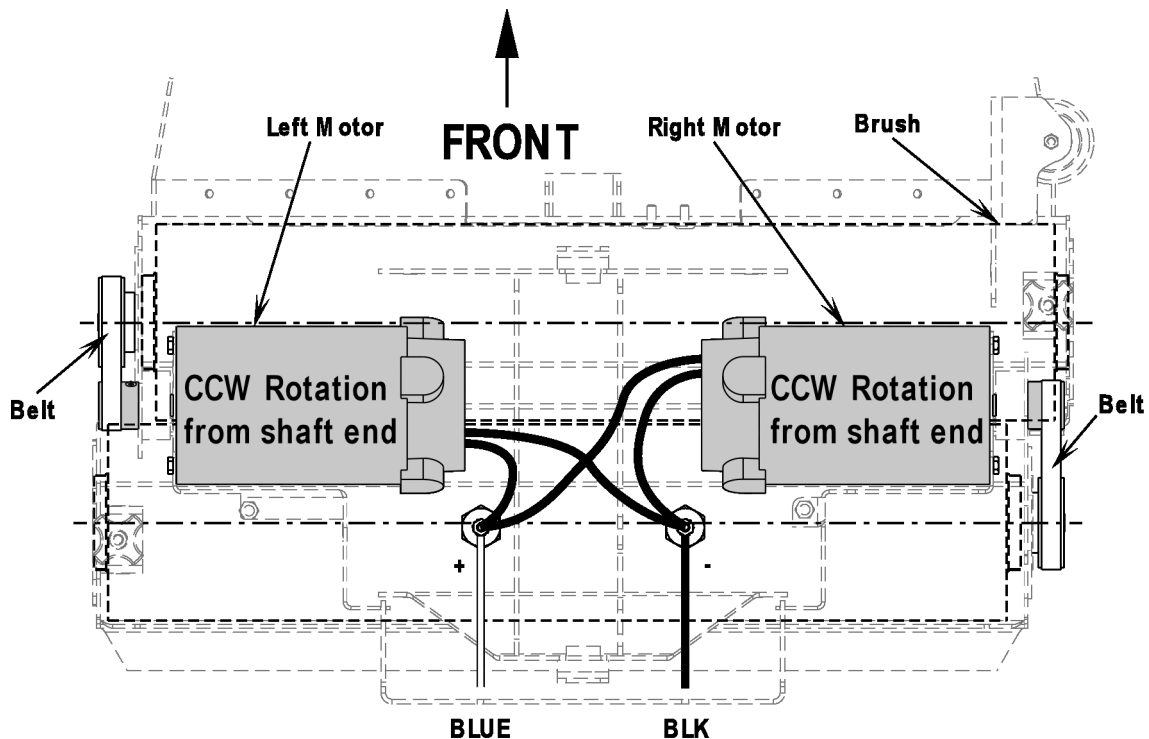

# SOLUTION SYSTEM

## FUNCTIONAL OVERVIEW

See Figure 1. Two molded plastic (polyethylene) tanks rear recovery and the main body structure store the machine's extraction solution. Total machine solution capacity is 45 gallons (170 L). Plumbed into the solution shut off Valve (C) outlet is a serviceable spin off Filter Housing Assembly (D) that keeps debris from entering the Solution Pump (E) and solenoid valves (L1 & L2). Also fitted between the storage tanks is a short flexible Drain Hose (F) to drain both tanks for system maintenance.

The electrical circuit that turns on (energizes) the solenoid coils is activated through the combined operator panel buttons and main controller assembly E1. Note: See the Know Your Machine section in this manual for a detailed explanation of the complete solution operation modes. The two electrical solenoid valves L1 maintenance and L2 restoration control (start and stop) the two specific defined solution nozzle outputs. The pump's flow volume is directed through one or the other operator selected (turned on) solenoid valve by hoses to the two separate brush nozzles A & B. Nozzle (A) directs the solution spray pattern onto the scrub brush when in the maintenance extraction mode (minimum flow). Nozzle (B) directs the solution in front of the scrub brush when in the restoration mode (maximum flow).

**FIGURE 1**

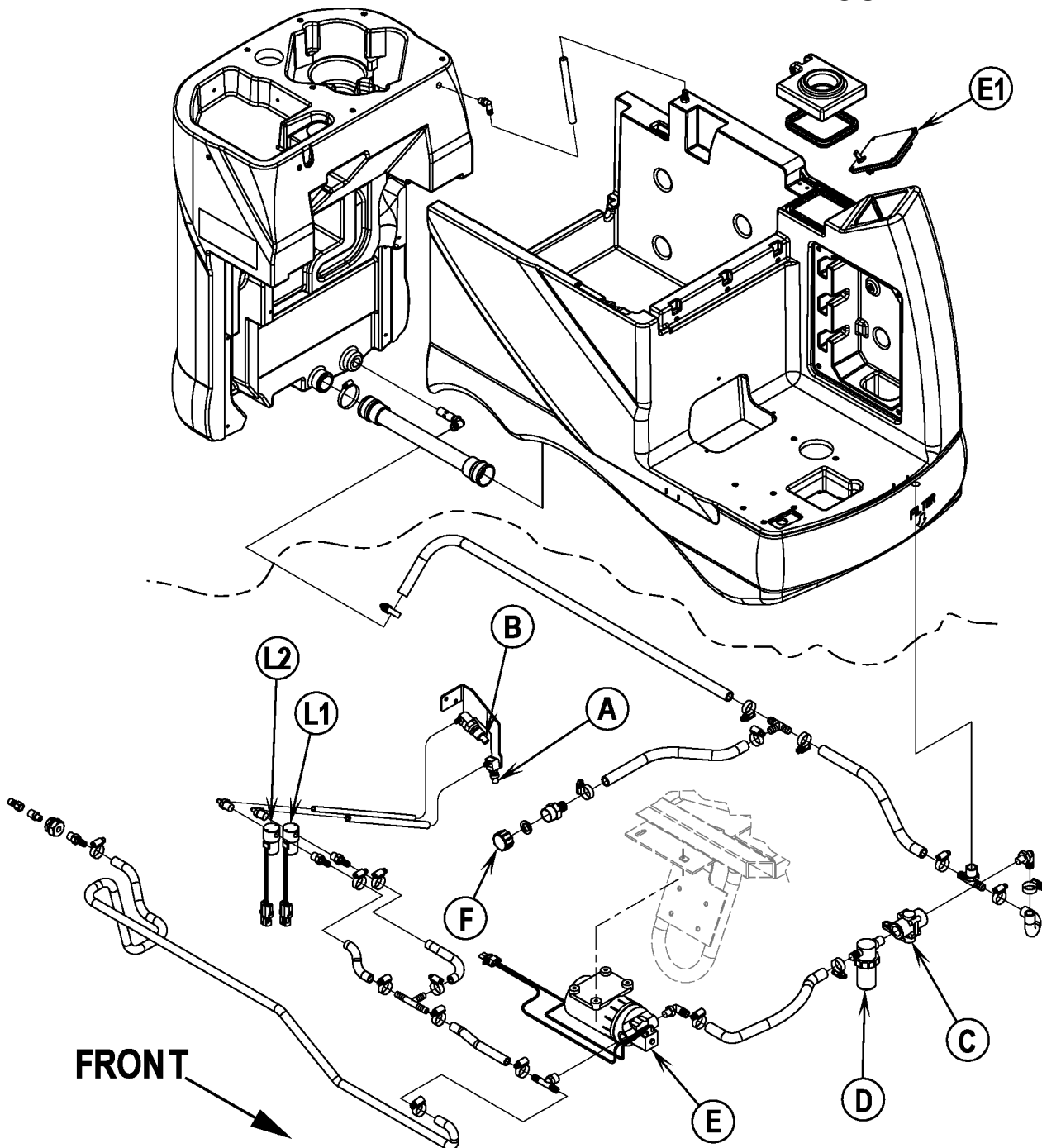

## OPERATIONAL OVERVIEW OF THE SOLUTION PUMP & SOLENOID FUNCTIONS

### Solution Delivery in the Auto Mode

Starts with the operator turning on the main power key switch then selecting either the maintenance or restoration mode switch.

#### Positive (+) battery circuit inputs and outputs

Inputs:

- A Solenoid circuit control coil (+) voltage input to control board E1 connector J2 pin #'s 6 & 7 (wire colors Brn/Yel).
- A closed S1 key switch supplies (+) input voltage to the E1 terminal J2 pin #10 (wire Brn). This powers up (turns on) the control board's processing logic functions.
- A closed S2 operator safety seat switch enables allows the starting of the entire automatic machine scrubbing system functions. Its E1 terminal connection is J4 pin #11 (wire Orn).

Outputs:

- A control board E1 battery (+) voltage output from the solenoid accessory terminal connection J2 pin #8 Wht/Brn wire.

#### Negative (-) battery circuit inputs and outputs

Inputs:

- A main (-) battery ground input for the control board E1 terminal J4 pin#8 BLK wire. This supports the operation of the boards processing logic functions.
- Battery ground supply input for all the (control boards) negative output coil circuits. Its E1 terminal connection is J2 pin #5 (wire Blk).

Outputs:

- A battery ground output from the E1 control board terminal connector J2 pin #3 wire Vio/Blk for the L1 solenoid or J2 pin #4 wire Wht/Grn for the L2 solenoid. This controlled output turns on and off the L1 & L2 solenoid coils that stops and starts the solution flow through the valve body selected. This occurs every time the throttle is moved off its neutral setting into forward.

### Solution Delivery in the Accessory Mode

Starts with the operator only having to turn on the main power key switch.

#### Positive (+) battery circuit inputs and outputs

Inputs:

- Accessory/solenoid circuit (+) voltage input to control board E1 connector J2 pin #'s 6 & 7 (wire colors Brn/Yel).
- A closed S1 key switch supplies (+) input voltage to the E1 terminal J2 pin #10 (wire Brn). This powers up (turns on) the control board's processing logic functions.

Outputs:

- A control board E1 battery (+) voltage output from solenoid accessory terminal connection J2 pin #8 Wht/Brn wire. This feeds the pump pressure switch S3, which is built into the pump M4. The pressure switch is normally closed and will open when the head pressure reaches its cutout limit of 100 PSI. When the operator depresses the accessory wand trigger valve the trapped solution pressure drops below 100 PSI and the pump will run.

#### Negative (-) battery circuit inputs

- A main (-) battery ground input to the control board E1 terminal J4 pin #8 BLK wire. This completes the circuit support for the operation of the board's processing logic functions.
- A direct battery ground input for completion of the M4 pump circuit

## FIGURE 2

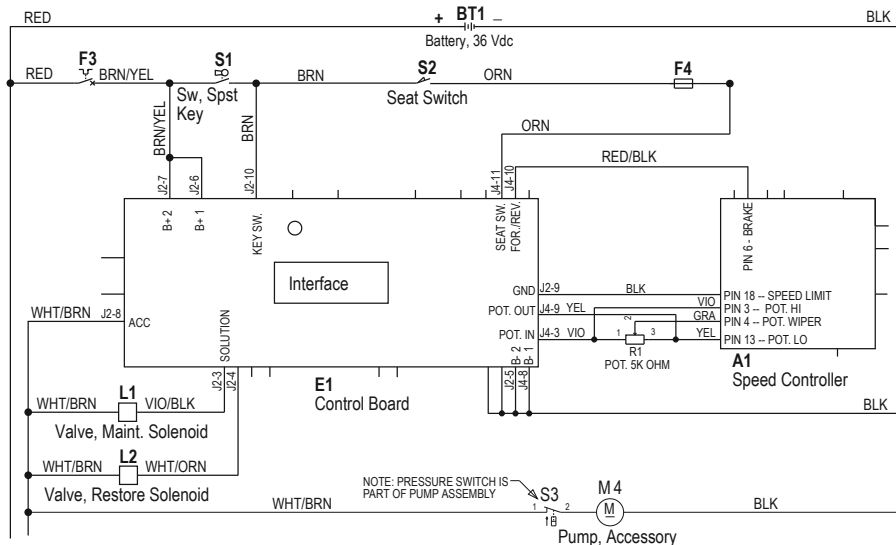

# SOLUTION SYSTEM

## TROUBLESHOOTING GUIDE

Mechanical / Electrical / Plumbing

Problem	Possible Cause
Inadequate or no solution flow	No solution in the tank
	Main solution flow shut off valve arm is in the closed position
	Clogged solution filter, hoses & solenoid valves
	Defective solution solenoid coils (L1 & L2)
	Solution system fault in the main controller E1*

\*On all models the solution system's electrical solution solenoids L1 & L2 (maintenance & restoration modes) are monitored by the main controller E1 to detect any system function failures (error codes). Detected error codes from the main controller are displayed on the **(G)** hourmeter LED operator panel display as they occur. Note: Reference the *Main Control Board Troubleshooting Guide* in the electrical system of this manual for specific fault descriptions and service repair actions.

## SOLUTION SYSTEM MAINTENANCE

- **Solution Tank:** See Figure 1. Weekly empty the solution tank; remove the solution Drain Hose **(F)** from its storage area (located underneath the left side of chassis). Direct the hose to a designated "Disposal Site" and flush the tank with clean water.
- **Solution Filter:** Remove and clean the inline Solution Filter **(D)**. To access the filter housing for removal, work underneath the middle front of the solution tank see molded "FILTER " callout. No tools are needed to remove the filter (hand tighten only). **Service Tip:** The manual solution shut off arm must be placed in the full CLOSED position (located next to filter). This prevents loss of solution when servicing the filter strainer with a partial or full tank.

## MAJOR COMPONENTS SPECIFICATIONS

Nozzle and Pump Data	
Components	Flow Rate GPM / Working Pressure
Nozzle (A) "Maintenance" Spec. .057" orifice diameter Hardened Stainless Steel Nozzle tip I.D. QSTK-SS-3.0	.55 GPM
Nozzle (B) "Restoration" Spec. .091" orifice diameter Brass Nozzle tip I.D. QTKA-BR7.5	.98 GPM
Pump Specifications	Pressure relief switch opens at 100 PSI Max. flow rate 1.6 GPM Max. current 3A (average current 2.7A)

### NOZZLE MAINTENANCE

See Figure 4. To inspect and clean both nozzles no tools are needed. First remove the Wing Nut (G) that secures the nozzle bracket (tree) and pull it from the brush housing slots with the hoses still connected.

To remove a nozzle to clean or replace just grip the nozzle tip and at the same time press in and twist it a 1/4 turn to separate it from the nozzle body. Note: Suggested once a week to inspect and clean nozzles.

Clean by soaking nozzles overnight in a full strength vinegar solution or properly diluted and handled meratic acid solution to remove build up of chemical deposits. Note: Do not ream out (increase) the orifice by cleaning with a drill bit. As this will affect the nozzle working pressure and spray pattern.

### NOZZLE FIXTURE INSTALLATION

- 1 Apply small amount of thread sealant (Loctite #242-blue) to the fixture threads.
- 2 See Figure 3. Thread the Nozzle Fixtures (H) into each brass barb.
- 3 Position nozzle fixture as shown (nozzle fixture flat must be 90° to bracket arm).

**FIGURE 3**

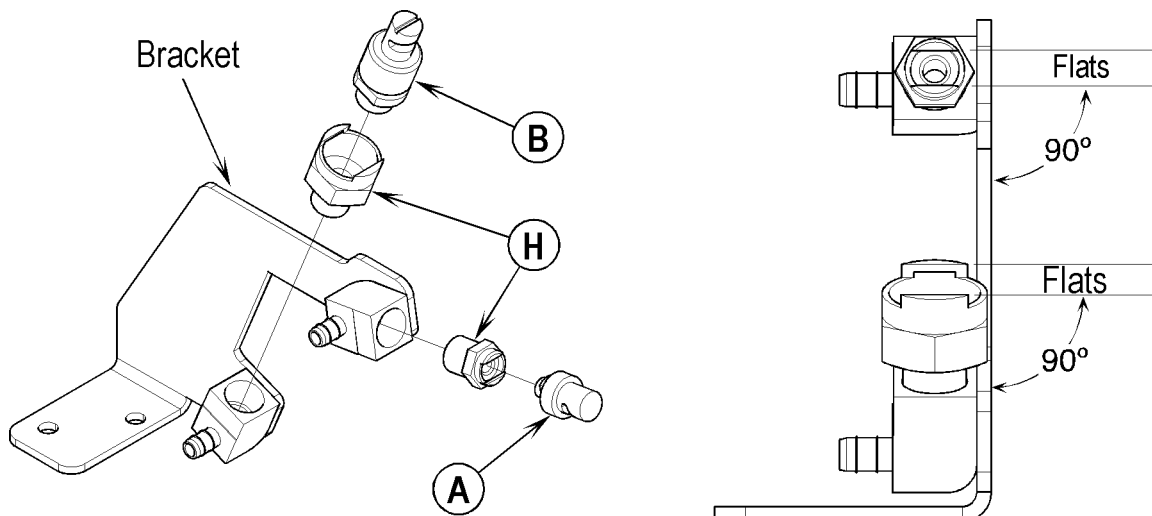

# SOLUTION SYSTEM

## SOLUTION PUMP REMOVAL

### ⚠ CAUTION!

Disconnect the machine's battery pack connector (13) before servicing machine.

- 1 See Figure 4. Drain the solution tank using the Drain Hose (F) or put the flow shutoff Valve (C) into its closed position to prevent the uncontrollable solution loss.
- 2 Loosen the (3) Hose Clamps (I) and remove the hose ends from the solution Pump (J) inlet and outlet fittings.
- 3 Cut the pump wiring harness tie straps then disconnect the pump wiring connector.
- 4 Remove the (2) (K) Screws that secure the pump assembly to the chassis then pull the pump out from underneath the machine. **Service Tip:** Use a long thin shaft #2 Phillips screwdriver to access the two pump mounting screws.

## SOLUTION SOLENOID VALVE ASSEMBLY REMOVAL

- 1 See Figure 4. Put the solution flow shutoff Valve (C) into its closed position and the scrub deck in the down position then disconnect the battery pack.
- 2 Block rear wheels to prevent machine from rolling then jack up the front of the machine 3-4 inches.

### ⚠ CAUTION!

Support machine with proper blocking for safety.

- 3 Cut the necessary wiring harness tie straps used on the Solenoid Valve Assembly (L) then separate the wiring connectors for each valve.
- 4 Remove the two (M) screws that secure the solenoid mount bracket to the chassis.
- 5 Remove the wing nut (G) that retains the nozzle tree (bracket) and pull it off from the deck.
- 6 Loosen the necessary hose clamps from the solenoid valve that needs service then pry the hoses off their fittings.
- 7 Remove the two screws that fasten the valve body to the mount bracket to complete its removal.

FIGURE 4

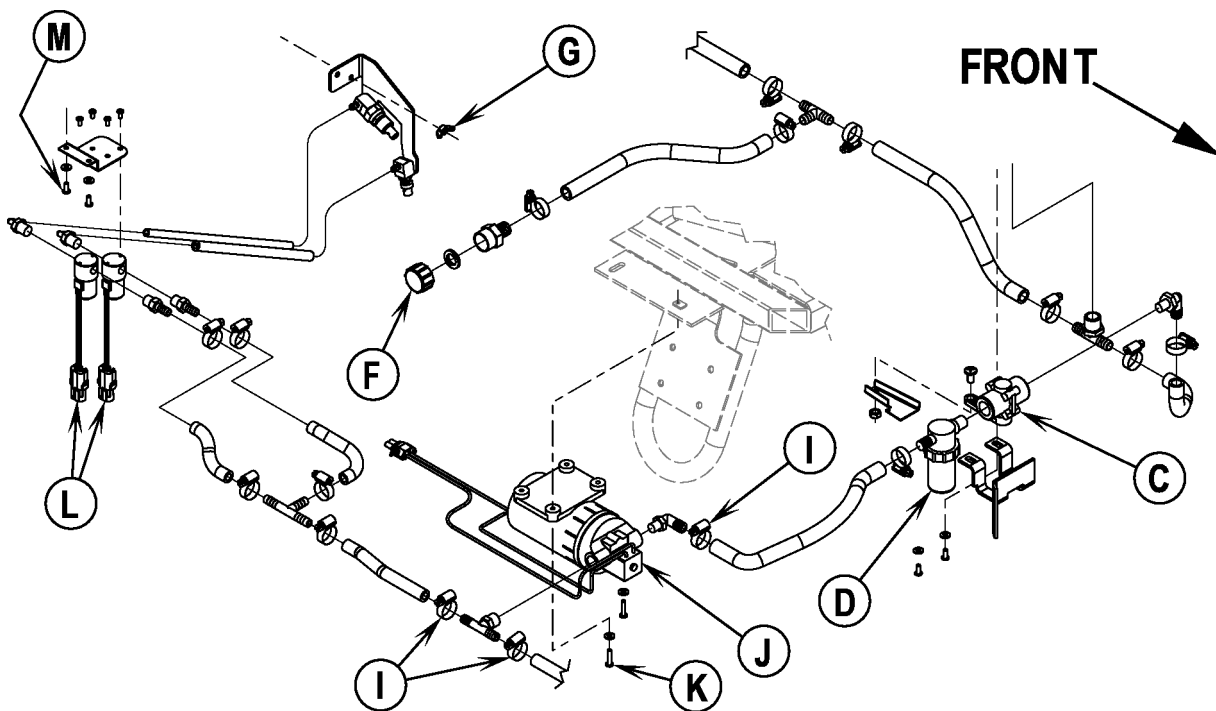

## SOLENOID VALVE DISASSEMBLY AND CLEANING

Note: See Figure 5 for valve disassembly & cleaning.

**Service Tip:** To just clean the valve assembly of any trapped debris it isn't necessary to completely remove it from the chassis mount bracket. Follow the short cut steps listed.

- 1 Use a flat bladed screwdriver to hold the slot on the end of the Valve Spool (N) and remove the Nut (O). Next pull off the metal protective Cap (P), Coil (Q) and Washers (R). Use the screwdriver again and turn out (remove) the valve spool and Piston (S) (be careful not to lose any internal parts).
- 2 Thoroughly wash out all debris from the Valve Body Seat (T) then reassemble and test the solenoid for proper operation.

FIGURE 5

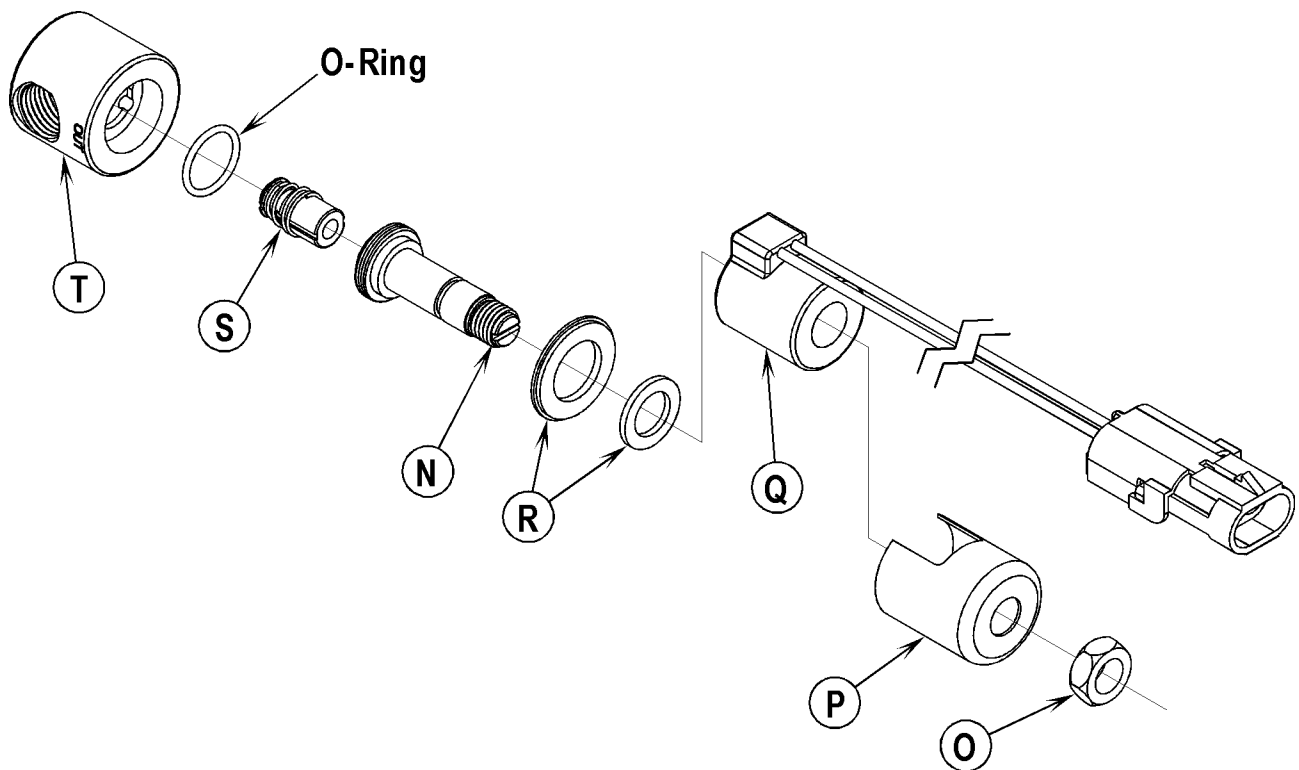

# RECOVERY SYSTEM

## FUNCTIONAL OVERVIEW

### Vacuum / Recovery System General

To start the extraction wastewater is lifted out of the carpet pile by airflow created by two 3 stage 36V vacuum motors. See Figure 1. The wastewater and air enter at the two vacuum pick-up tools through their small narrow shoe openings that contact the carpet surface. The narrow shape of the shoe openings are designed to help speed up the airflow producing the needed suction to lift the waste water out of the carpet. Two smaller recovery hoses are connected together and direct the high-speed air/water movement to one large hose connected to the tank inlet. At this point the air and water enters the large flexible sealed recovery bladder, where the air slows down because of the increased (size) of the tank. With the decreased air speed the heavier water falls to the bottom of the recovery bladder. Then at the same time the airflow continues through shutoff float, vacuum motors and is exhausted out the bottom of the vacuum motor housing.

The vacuum system uses a shutoff float to prevent the tank from being overfilled and also stops any water from being sucked into the vacuum motors. This shut-off function works when the float ball reaches its tank full level and the ball becomes seated in the float housing. This action then causes a large restriction to the vacuum airflow and the main controller E1 senses a large electrical current load change (lower Amps) to the vacuum motors. This lower than normal vac circuit current load change tells the main controller that the recovery tank is full. This automatically shuts off the vacuum and scrub systems and displays "FULL" on the hourmeter/status display telling the operator that the recovery tank has become full.

**FIGURE 1**

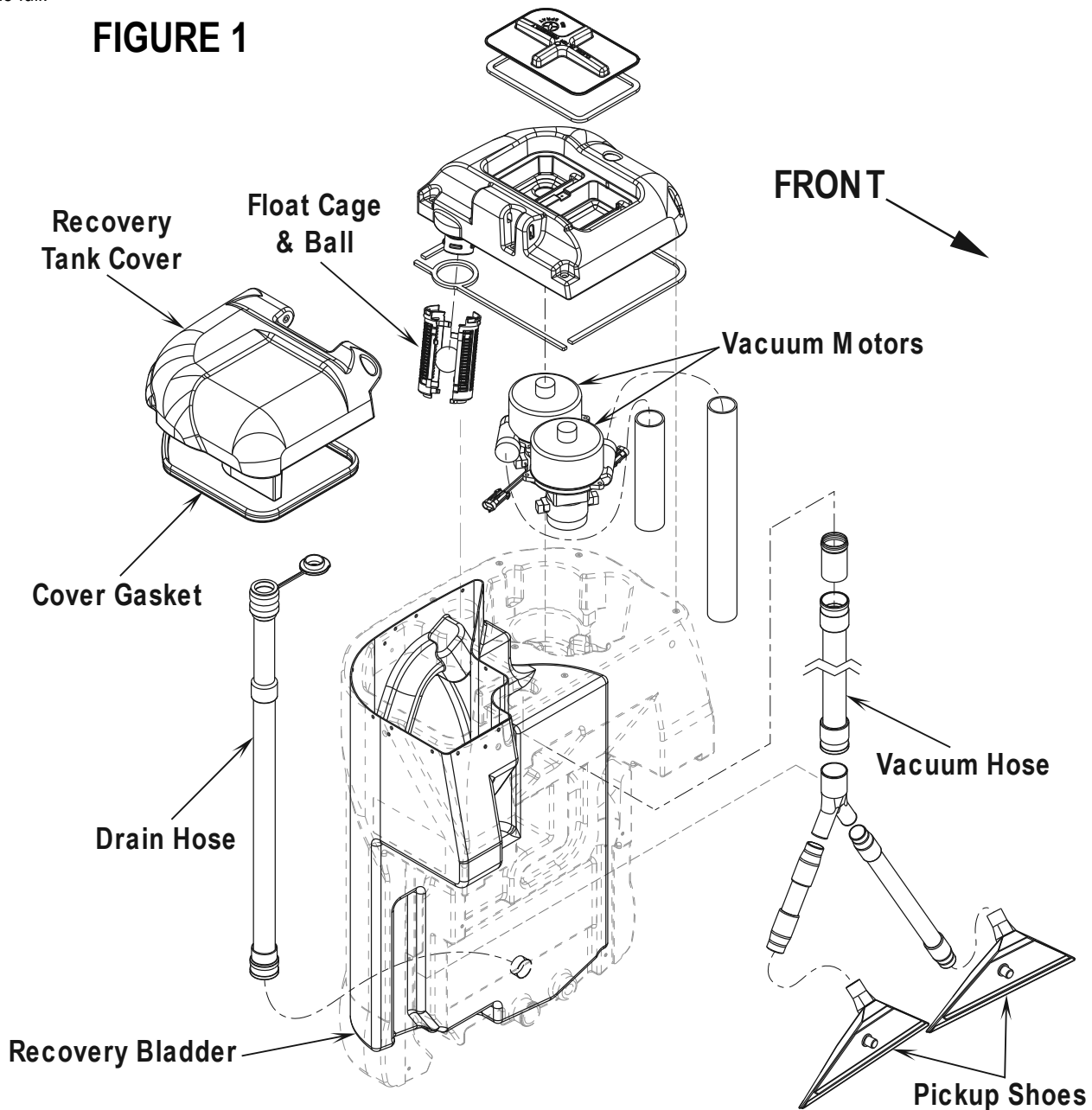

# RECOVERY SYSTEM

## VACUUM MOTOR CIRCUIT OVERVIEW

There are two vacuum switch operator modes, Auto vacuum for machine transport extraction use and manual On/Off stationary optional accessory uses. Note: see the *Know Your Machine* section in this manual for a detailed description of the vacuum operation modes.

### Vacuum motor system function in the Auto Mode:

Starts with the operator turning on the main power key switch then selecting either the maintenance or restoration mode function switch.

#### Positive (+) battery circuit inputs and outputs

Inputs:

- See Figure 2. A Solenoid circuit control coil (+) voltage input to control board E1 connector J2 pin #'s 6 & 7 (wire colors Brn/Yel). Note: This input voltage supplies all the machine's accessory and solenoid coil circuits (solution, vacuum, brush, headlight, warning beacon etc.).
- A closed S1 key switch supplies (+) input voltage to the E1 terminal J2 pin #10 (wire Brn). This powers up (turns on) the control board's processing logic functions.
- A closed S2 operator safety seat switch enables the starting of the entire automatic machine scrubbing system functions. Its E1 terminal connection is J4 pin #11 (wire Orn).

Outputs:

- A control board E1 battery (+) voltage output from the solenoid accessory terminal connection J2 pin #8 Wht/Brn wire completes the positive voltage to the vacuum solenoid coil.

#### Negative (-) battery circuit inputs and outputs

Inputs:

- A main (-) battery ground input for the control board E1 terminal J4 pin #8 wire Blk. This supports the operation of the board's processing logic functions with the above mentioned S1 (+) key switch input.
- A battery ground input for all the (E1 boards) negative solenoid coil output circuits. Its E1 terminal connection is J2 pin #5 (wire Blk).

Outputs:

- A battery ground output from the E1 control board terminal connector J2 pin #2 wire Gra/Blk. This control board output completes the K2 vacuum solenoid coil circuit (Pos. & Neg.) and pulls in the vacuum solenoid load contact K2 making the vacuum motor(s) M5 & M6 run. This occurs every time the throttle is moved off its neutral setting and the vacuum switch is on. Note: When the throttle is returned to neutral the vacuum will remain on for 10 seconds and the indicator light will flash green.

## FIGURE 2

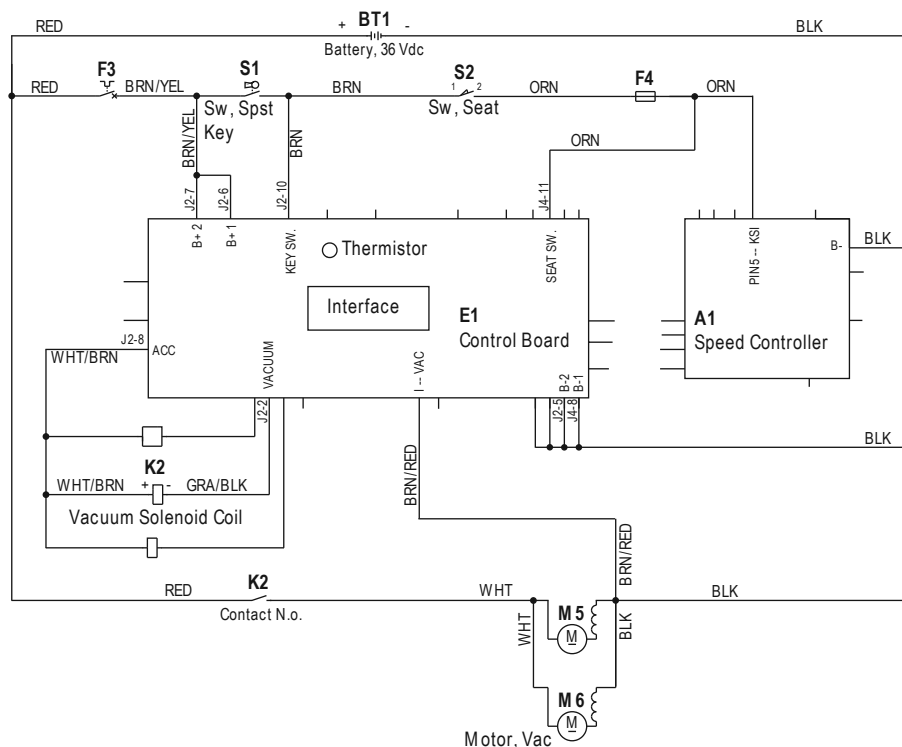

# RECOVERY SYSTEM

## VACUUM MOTOR CIRCUIT OVERVIEW (CONTINUED)

### **Vacuum motor system function in the Accessory On/Off Switch Mode:**

Starts with the operator turning on the main power key switch then selecting the accessory mode function switch.

Both Positive (+) battery and Negative (-) battery circuit inputs and outputs are the same as above except as noted below:

- The vacuum motors will run continuously without the (normal) machine auto mode interruptions. Examples: No foot pedal throttle inputs, no 10 sec. time delay shut-off, no auto full indicator display and system shut down, no operator in seat input.

## TROUBLESHOOTING GUIDE

When extracting the operator sees little or no (below normal) waste recovery water entering the recovery tank bladder, the vacuum system is not working properly. When a vacuum system performs poorly, it is usually because of one of the following problems:

**Vacuum Leak(s)** – Air flowing into the vacuum system past a bad gasket or leaky hose, damaged tank, or a leaky drain hose cap. A vacuum leak below the water line will create turbulence in the recovery tank, causing water to enter the vacuum motor.

**Restriction(s)** – Anything that blocks the flow of air through the system. Restrictions may also be caused by built-up debris in the pick-up tools, vacuum hoses, float cage or wherever the airflow is forced to make a sharp turn.

Both leaks and restrictions decrease the quantity of air flowing through the pick-up tools. The air that does go through the pick-up tools moves with less pressure and volume, so it has less pick-up power.

**Vacuum Electrical Components** – The vacuum systems major electrical components are monitored by the main controller to detect any system function failures (error codes). The system components covered are the vacuum motors and vacuum solenoid. Detected error codes from the main controller are displayed on the hour meter LED display as they occur. Note: Reference the *Main Control Board Troubleshooting Guide* in the Electrical System of this manual for specific fault descriptions and service repair actions.

## VACUUM / RECOVERY SYSTEM SERVICE MAINTENANCE CHECKLIST

Whenever there is a vacuum problem, it's best to check over the entire system. Use the checklist below as a guide, to thoroughly check the vacuum system.

- Clean built-up dirt from the inside of both vacuum pick-up (shoes) tools.
- Inspect the vacuum motors duct (plenum housing) cover gaskets, clean foam air inlet filters and screens.
- Inspect the hose between the pick-up tools and the recovery tank, rinse any built-up dirt from the hoses. Replace the hose(s) if it is kinked or damaged.
- Inspect and make sure the gaskets on the recovery tank covers are sealing and not damaged.
- Inspect and clean the vacuum motor float cage, float ball and shut-off seat.
- Make sure that the recovery tank drain hose cap seals airtight.

## MAINTENANCE OF VACUUM FILTER AND FLOAT CAGE

See Figure 3. To inspect and clean the vacuum motor foam filter just lift open the tethered Vac Duct Cover **(A)**. Remove the filter by pulling it out from the housing opening. Clean the filter by vacuum or washing it out in warm water. Note: The filter must be completely dry before reinstalling.

To inspect the vacuum shut off float just open the right rear recovery tank cover to access the float cage assembly (back center in recovery tank). The cage openings must be kept free of any debris that can restrict maximum airflow. To keep it clean, wipe off with a rag regularly or remove and flush with water. The cage is a two piece design and can be snapped apart to separate. Note: Another method of accessing the cage float for servicing is to remove the (6) **(B)** Screws and remove the vacuum duct housing **(C)** from the recovery tank top opening.



## VACUUM MOTOR(S) REMOVAL

- 1 See Figure 3. Remove the vacuum duct Cover **(C)** that is secured to the recovery tank by a qty of (6) Screws **(B)**.
  - 2 Separate the wiring harness from each motor and lift motor(s) out from their mounting cavity.
  - 3 Inspect all the vacuum/recovery system Gaskets, (items **E, F, G & H**) also clean the vacuum motor(s) Foam Filters **(I, J & K)**, Screens **(L)** and Exhaust Hoses **(M)**.
  - 4 Inspect the carbon motor brushes, if less than 3/8" (10mm) in length replace.
- \* Service Note: The hinged Tank Cover **(D)** can easily be separated from the vacuum Duct Cover **(C)** by removing the slotted Pin **(N)** (by using a flat bladed screwdriver).

## RECOVERY TANK REMOVAL

- 1 Drain both the solution and recovery tanks by using the system drain hoses.
- 2 See Figure 3. Loosen the hose clamps for both the small and large solution Hoses **(O) & (P)** (location bottom backside of tank) then remove the hoses from their tank fittings.
- 3 Separate the vacuum Hose **(Q)** from the Y-shaped vacuum system Hose Assembly **(R)** (located inside the right rear wheel).
- 4 Pull the solution system vent Hose **(S)** off from the barbed elbow connected to the recovery tank.
- 5 Swing open the operator seat platform (set the prop rod) and pull apart the vacuum motors' harness connector (located left rear of battery compartment).
- 6 Open the hinged recovery tank Cover **(D)** and grip the top inside edge of the tank bladder and pull straight up to complete the tank's separation from the machine's solution tank/chassis assembly.
- 7 Next guide the tank off the rear of the machine supporting the tank on its left corner to prevent crushing of the vacuum hose, then lay it down onto the floor. Note: There is some weight to the tank assembly. Be careful when lifting it off ask for an extra helper to assist.

# RECOVERY SYSTEM

## RECOVERY TANK BLADDER REMOVAL

- 1 Drain both the solution and recovery tanks by using system drain hoses.
- 2 See Figure 3. Remove the (6) screws that secure the combined recovery tank and vacuum motor Cover Assembly (C). Then pull-up the cover and completely remove the cover assembly by carefully guiding the float cage through its tank opening.
- 3 Loosen the drain Hose Clamp (T) and pull the hose off the tank fitting, next pry the plastic hose bushing (U) off the tank fitting.
- 4 Remove from the tank fitting the item (V) conduit lock nut by striking the nuts notched lugs (CCW) with a flat bladed screwdriver. Also remove and save the Washer (W) and sealing O-ring (X).
- 5 From the front side of the tank loosen the Hose Clamp (Y) and pry off the solution feed Hose (O) as shown. Next use a lock pliers and remove (unthread) from the tank the Elbow Fitting (Z).
- 6 From outside of the tank push the bladder drain fitting through its mounting hole. Note: Observe that the bottom bladder drain fitting clears the tank-mounting hole and reach down inside the bladder and pull it up enough to complete its removal from the tank-mounting hole.
- 7 Use a 7/16-inch wrench and Phillips screwdriver and remove the (5) (AA) Screws and (5) (AB) Nuts that secure the bladder support straps as shown.
- 8 Pull the top metal bladder supports down from the tank mount opening then collapse the bladder and pull it up and out of the tank opening. When replacing a new bladder it will be necessary to remove and save the metal supports.

Hole #	Hardware used
1	Scr, Flat Phil SS 1/4-20 x 2.00    Wsh, Flat SAE SS 1/4    Nut, Acorn SS 1/4-20 High Crown
2	Scr, Flat Phil SS 1/4-20 x 2.00    Wsh, Flat SAE SS 1/4    Nut, Acorn SS 1/4-20 High Crown
3	Scr, Flat Phil SS 1/4-20 x 2.25    Wsh, Flat SAE SS 1/4    Nut, Acorn SS 1/4-20 High Crown
4	Scr, Pan Phil SS 1/4-20 x 1.00    Wsh, Flat SAE SS 1/4    Nut, Hex Nyl Loc SS 1/4-20
5	Scr, Pan Phil SS 1/4-20 x 2.25    Wsh, Flat SAE SS 1/4    Nut, Acorn SS 1/4-20 High Crown

FIGURE 4

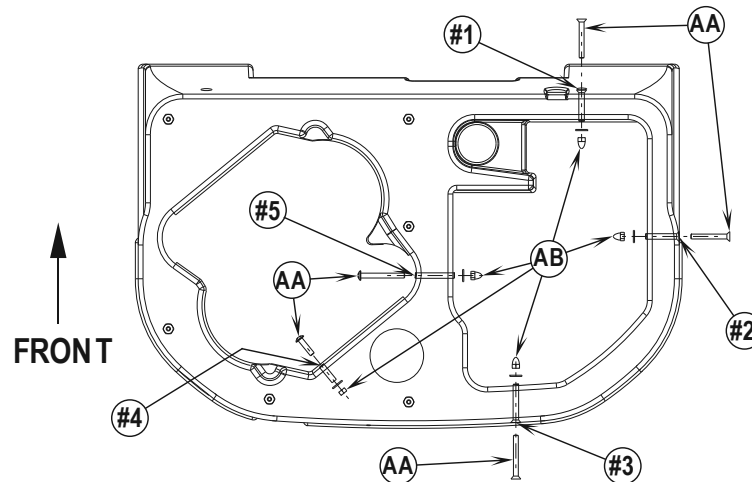

## RECOVERY TANK BLADDER INSTALLATION

- 1 Mix a one-quart volume of water and soap solution in a small spray bottle then spray the insides of the recovery tank and the outside of the bladder just before installing. This needs to be done to help the bladder slide easily when positioning it in place. **Note:** Do not use any silicone-based products that will be in contact with the bladder, damage to the bladder will result.
- 2 Install the special rope and pulling bar inside the bladder as shown. **Service Tip:** Figure 5 shows the dimensions for building the pulling tool needed to install the drain fitting through the bottom tank mounting hole.
- 3 Next feed the end of the rope from the drain fitting of the bladder through the bottom of the tank hole to the outside.
- 4 Carefully push the bladder down into the recovery tank with the needed assistance of pulling on the rope.
- 5 Working through the tank drain outlet opening pull the rope and pry the bladder tube fitting down where it is partially visible.
- 6 Spray additional soap solution through drain hole and hold the rope firmly while prying down on the fitting using a screwdriver to keep the fitting from pulling away from the tank hole (use caution to not damage the bladder).
- 7 Remove the screwdriver and quickly slide in a piece of a rounded end steel shafting (approximately 3/4" in Diameter and 18" in length, a large auto mechanics breaker bar works well) into the drain opening.
- 8 Pull down on the rope and quickly pull up on the lever turning and drawing the drain tube into the tank hole opening. Next pull out from the top bladder opening the drain tube pulling tool by its free rope end.
- 9 Reinstall all of the previously removed plumbing fittings, support straps, hardware and hoses. **Service Tip:** To easily install the plastic drain hose Bushing (U) onto the aluminum drain tube drop the bushing into a small cup of warm water to soften.
- 10 Fill the solution tank and check for leaks.

# RECOVERY SYSTEM

## FIGURE 5

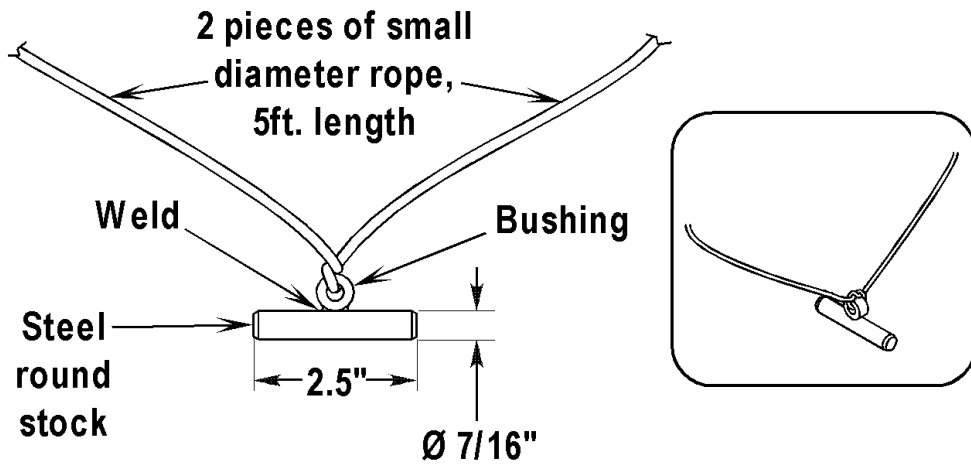

## FIGURE 6

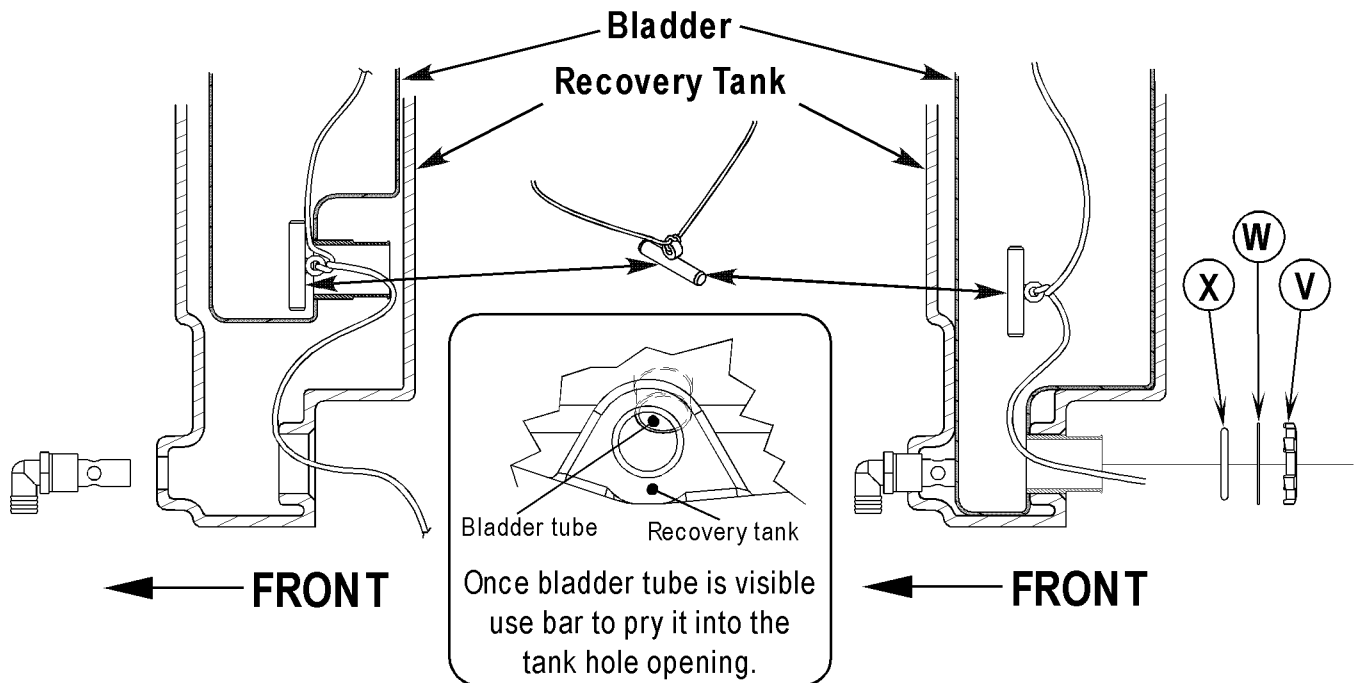

# RECOVERY SYSTEM

## VACUUM SHOES REMOVAL FOR MAINTENANCE

- 1 With the Master Key Switch (**J**) off have the operator check and clean the vacuum shoes daily.
- 2 See Figure 7. Pull off the two vacuum recovery hoses from the vacuum shoe inlets, then loosen the two black Knobs (**AC**) and lift up and pull out the Retainer Bars (**AD**) to separate them from the scrub deck pins.
- 3 Next pull back the pickup shoe from the deck support bearing mounts to complete their removal.
- 4 Rinse the shoe housings with warm water to remove any build up of string, hair or carpet fibers. Then reinstall shoes in reverse order of removal.

FIGURE 7

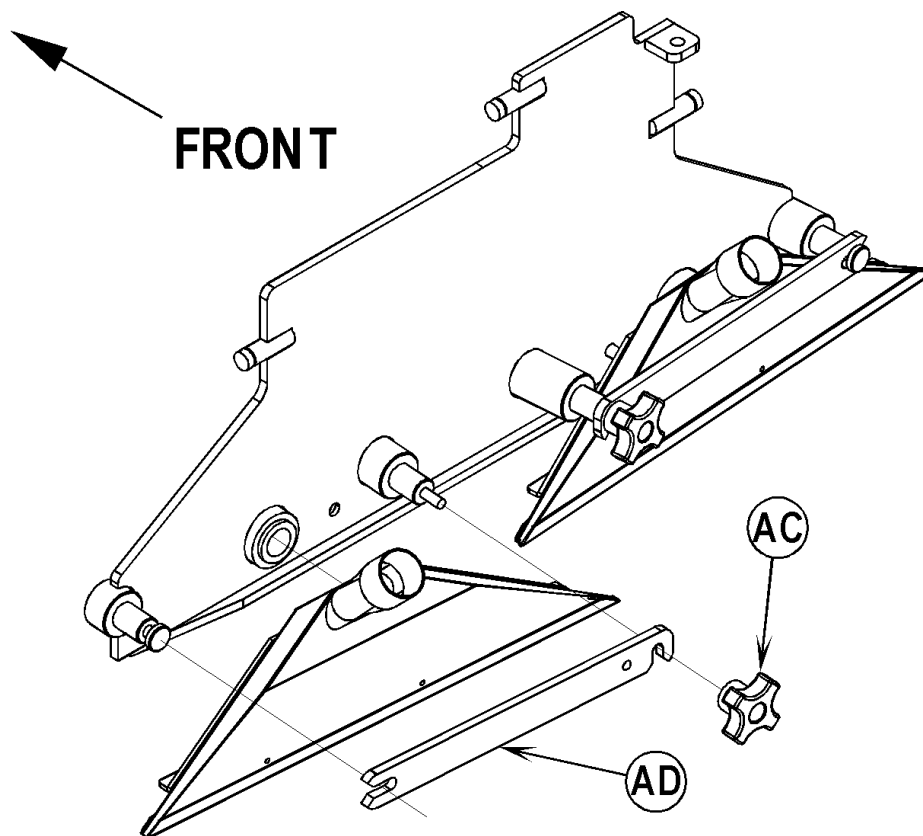

## BATTERY SPECIFICATIONS

- Use a combination of multiple 2-volt cell units (wired in series) to construct a 36 Volt DC battery pack system.
- Nilfisk recommended battery pack capacity is a 238 or 305 AH @ 20 Hour Rate deep cycle battery system (six 6V-batteries). Note: The battery pack must fit the battery compartment size listed in *Specifications*.

## BATTERY CHARGER SPECIFICATIONS

- Use a 36 Volt DC output charger matching the DC battery pack voltage and the input AC line voltage supply being used.
- Always when selecting a battery charger follow the recommendation of the battery supplier to match the proper charger DC output amperage to the amp/hour rating batteries being installed. This will prevent the battery pack from being over or under charged.
- The recommended 238 AH battery should be matched to a 36V, 20 Amp charger.
- The recommended 305 AH battery should be matched to a 36V, 25 Amp charger.

## INSTALL THE BATTERIES

### ⚠ WARNING!

Use extreme caution when working with batteries. Sulfuric acid in batteries can cause severe injury if allowed to contact the skin or eyes. Explosive hydrogen gas is vented from inside the batteries through openings in the battery caps. This gas can be ignited by any electrical arc, spark or flame.

#### When Servicing Batteries...

- Remove all jewelry.
- Do not smoke.
- Wear chemical goggles, rubber gloves and a protective apron.
- Work in a well-ventilated area.
- Do not allow tools to touch more than one battery terminal at a time.

### ⚠ CAUTION!

Electrical components in this machine can be severely damaged if the batteries are not installed and connected properly. Batteries should be installed by Nilfisk or by a qualified electrician.

- 1 Remove the batteries from their shipping crate and carefully inspect them for cracks or other damage. If damage is evident, contact the carrier that delivered them or the battery manufacturer to file a damage claim.
- 2 Turn the Master Key Switch (J) OFF (O) and remove the key.
- 3 To access the battery compartment tip the operator's seat forward and set the prop rod. Remove the battery cables from inside the battery compartment.
- 4 Your machine comes from the factory with enough battery cables to install six (6 volt), 305 Amp hour batteries. Using two people and an appropriate lifting strap, carefully lift\* the batteries into the compartment tray exactly as shown on machine decal (Figure 1).
- 5 The terminals on the battery cables are marked "+" for positive and "-" for negative. Install the battery cables as shown, with the terminals marked "+" on the positive battery terminals and the terminals marked "-" on the negative terminals. Position the cables so the battery caps can be easily removed for battery service.
- 6 Carefully tighten the nut in each battery terminal until the terminal will not turn on the battery post. Then tighten the nut half an additional turn. Do not over-tighten the terminals, or they will be very difficult to remove for future service.
- 7 Coat the terminals and posts with spray-on battery terminal coating (available at most auto parts stores).
- 8 Put one of the black rubber boots over each of the terminals and retain with supplied tie straps.
- 9 Connect the battery pack connector to the Machine Battery Connector (22) and close the operator's seat platform.

\*Note: Removal of the recovery tank can make battery installation easier.

### FIGURE 1

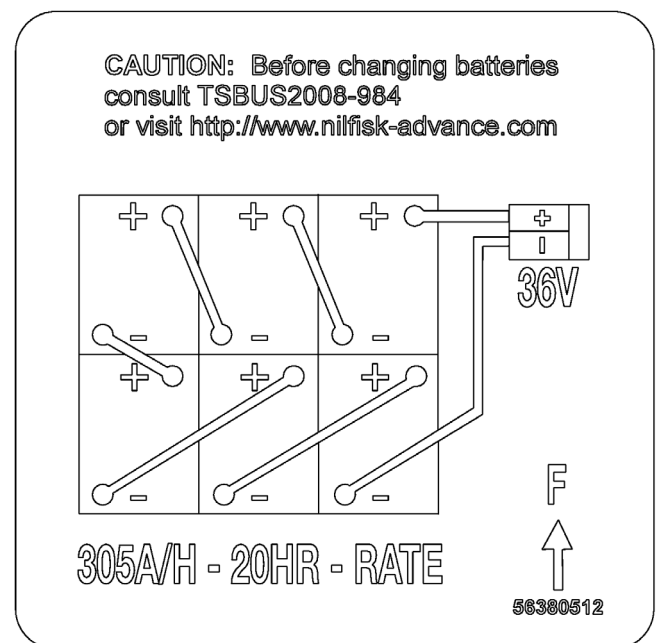

# ELECTRICAL SYSTEM

## DESCRIPTION OF THE BATTERY LOW VOLTAGE CUTOUT FEATURE

All models discussed in this manual are equipped with a low voltage cutout feature to prevent over-discharging of the batteries. When a machine's battery pack voltage falls below specifically defined thresholds (voltage settings) the scrub system is automatically shut down. The cutout level is adjustable. The standard lead acid battery (wet cell) setting is 1.72V per cell and alternate maintenance free battery (gel cell) setting is 1.81V per cell. The standard setting is factory selected and should be used unless the battery manufacturer specifies the higher cutout voltage.

**Special Service Note:** On all machines (36V) a minimum recharge voltage of 2.09 volts per cell must be reached to allow the scrub brush and solution system to (reset) function again. The 36V-battery pack must increase to a 37.6-volt minimum.

## DESCRIPTION OF THE BATTERY CONDITION INDICATORS

The Battery Condition Indicator (**K**) will give an indication of the state of charge of the batteries. The battery condition indicator will retain the state-of-charge even if the key has been turned off. The state-of-charge indication is reset to full charge when the batteries have been recharged. It is also possible to choose between two different low voltage thresholds depending on whether maintenance free or standard batteries are being used (**have qualified service engineer perform this selection\***). NOTE: The following percentages are based on *useable* battery capacity not total battery capacity. Therefore, 100% discharge = 80% of total battery capacity for standard wet cell batteries or 70% of total battery capacity for maintenance free batteries.

### Explanation of Battery Indicator Lights and Voltage Ranges

Battery Indicator	% of Discharge	36 volt	
		Standard	Alternate
Green	Full to 50%	34.0+	34.5+
Green & Yellow	50% to 75%	33.0-34.0	34.0-34.5
Yellow	75% to 90%	32.0-33.0	33.5-34.0
Yellow & Red	90% to 95%	31.5-32.0	33.0-33.5
Red	95% to 99%	31.0-31.5	32.5-33.0
Flashing Red/Cutoff	100%	<31.0	<32.5

**\*Important Note:** See the *Main Control Board Special Program Options* manual section (located in the Electrical System) and follow the instructions for changing the low voltage cutout threshold.

## CHARGING THE BATTERIES

Charge the machine's battery pack each time the machine is used, or when the Battery Condition Indicator (**K**) is showing red flashing indicator lights. Note: The machine also uses a special low voltage cutout that inhibits the scrub system see in this manual section the *Description of the Battery Low Voltage Cutout Feature*.

### To Charge the Batteries...

- 1 Depress the Battery Disconnect (**13**).
- 2 Open the Battery Compartment Cover (**16**) to provide proper ventilation.
- 3 Push the connector from the charger into the Battery Connector (**22**).
- 4 Follow the instructions on the battery charger.
- 5 Check the fluid level in all battery cells after charging the batteries. Add distilled water, if necessary, to bring the fluid level up to the bottom of the filler tubes.

## WARNING!

Do not fill the batteries before charging. Only charge batteries in a well-ventilated area. Do not smoke while servicing the batteries.

## BATTERY MAINTENANCE

Proper maintenance of electric vehicle batteries can greatly extend their life. Well-maintained batteries may last up to 3 years, but failure after 1 year is common if maintenance has been poor.

There are 3 simple rules for good battery maintenance:

- **Maintain Proper Electrolyte Level (Weekly)** - Use distilled water in batteries whenever possible. If batteries are discharged, add just enough water to cover the plates in each cell. If batteries are fully charged, fill each cell to the bottom of the filler tube. **Do not over-fill the batteries! Do not add acid to batteries!**
- **Keep the Batteries Charged (Weekly)** - Batteries should be charged each time that a machine is used for more than 1 hour. Machine operators should open the battery compartment cover for charging, to avoid a concentrated build-up of hydrogen gas. Operators should follow the instructions provided with their specific battery charger, to determine how long the batteries should be charged. Even when a machine is stored, the batteries should be charged once a month to prevent the batteries from "sulfating". Almost all battery caps are vented, so there's no need to loosen or remove them for charging.
- **Keep the Batteries Clean (Monthly)** - Use a damp cloth to wipe dirt from the top of the batteries. Battery terminals must be clean and tight. If the tops of the batteries are wet after charging, the batteries have probably been over-filled or over-charged. Note: If there is acid on the batteries, wash the tops of the batteries with a solution of baking soda and water (2) tablespoons of baking soda to 1 quart of water.

## BATTERY TESTING

A battery problem is usually recognized by the machine operator, as a decrease in the machine's running time. This condition is usually caused by one or more "dead cells" in the battery system that is, one or more cells that is putting out less voltage than the other cells.

**Note:** Always charge batteries before testing.

There are 2 ways to find a dead cell:

- Use a hydrometer to check the specific gravity (or "state of charge") of the fluid in each cell. A dead cell is one that reads 50 points (or more) lower than the other cells.
- Use a volt meter to check the voltage of each battery with the scrub and drive motors running. The battery with the dead cell will read 1 or 2 volts lower than the other batteries in the system.

If the batteries in the machine are more than 1 year old, it's usually best to replace the whole set, rather than replacing just one battery.

The chart below shows the approximate "percent charged" of an electric vehicle battery at various specific gravity values, corrected to 80°F (26.7°C).

### APPROXIMATE STATE OF CHARGE

Charged	1.265 Initial Full Charge
100%	1.265
75%	1.225
50%	1.190
25%	1.155
Discharged	1.120

# ELECTRICAL SYSTEM

## ACTUATOR DRIVE NUT ADJUSTMENT

This manual section explains the steps for adjusting the drive nut (housing assembly) setting for the machine's scrub deck actuator motor. Reference the chart below that shows the IN & OUT dimensional specification for the actuator motor that is used on the BRX 700.

Part #	Actuator Motor	Drive Nut Housing Assy IN	Drive Nut Housing Assy OUT
56393303	Scrub Brush Lift (all)	1/4" (6.3mm)*	3-7/8" (98.5mm)*

\*The "Drive Nut Housing Assy IN/OUT Position" dimensions are measured when completely assembled. Reference points are the edge of the plastic Spring Housing Assembly as shown in Figure 3.

### General Instructions for All Actuator Motors

- 1 See Figure 2. This shows the special actuator power cord adapter (PN 56407502) that is needed to connect the machine's battery pack and actuator motor for setting the drive nut limit settings.
- 2 Open the machine battery compartment and disconnect the battery connector. The battery pack is needed to power the lift actuator motor to properly set the IN & OUT limit switches.
- 3 Connect the actuator motor to be tested to the power cord adapter end. Then connect the alligator clips from the cord adapter (red clip to the positive and black to negative) to battery connector or battery posts. The rocker switch is used to change the motor rotation in setting the correct drive nut dimension.

FIGURE 2

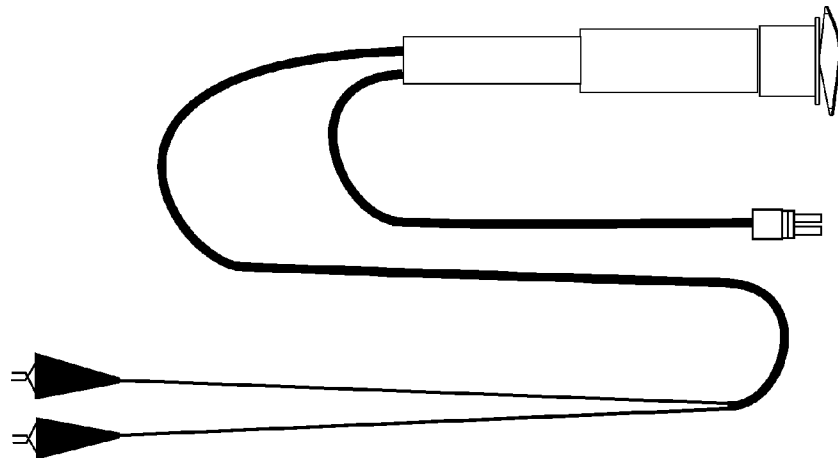

### Instructions for Scrub Brush Lift Actuator Drive Nut Adjustment

- 1 See Figure 3 and 4. On a new scrub lift actuator motor remove (spin-off) the Drive Nut (A) first slide on the short compression Spring (B) onto the actuator (lead screw) shaft. Next reinstall the plastic drive nut as shown (with the nut pin pocket away from the motor). Then finish assembly of remaining parts (long compression spring, Spring Housing (C) and mounting hardware).
- 2 Hold onto the spring housing assembly and press the rocker switch to run the drive motor and retract the spring housing towards the motor housing (its IN limit).
- 3 Measure the position of the spring housing assembly on the actuator shaft. Manually turn the spring housing assembly to the appropriate IN position shown in the chart above.
- 4 Hold the spring housing assembly then press the adapter cord rocker switch to run the drive motor to the OUT position (wait until the motor stops).
- 5 Measure the position of the spring housing assembly on the shaft and compare the measurement with the OUT position shown in the chart.
- 6 When the measurement doesn't match the dimension shown in the chart it is necessary to remove the Adjuster Cover (D) and adjust the OUT position.
- 7 To increase the travel of the spring housing assembly, turn the adjuster clockwise. To decrease the travel of the assembly, turn the adjuster counter clockwise.  
NOTE: Use a 1/2" (13mm) socket to turn the adjuster. Each click of the adjuster will change the spring housing assembly travel 1/16 inch (1.6mm).
- 8 After each adjustment, hold the spring housing assembly, run the actuator IN & OUT and check both dimensions. After checking that the spring housing limits are set correctly replace the adjuster cover. **Service Tip Note:** Use the above power cord adapter to help position the spring housing assembly (in or out) for ease in actuator motor installations.
- 9 After adjusting the actuator spring housing dimensions, follow the *Scrub Brush Lift Actuator Removal* manual section to reassemble.

**Service Tip:** See Figure 4. Note the correct orientation of the Spring Housing (C) when installing the complete motor assembly and also run the spring housing assembly to the IN (retracted) position for machine installation.

FIGURE 3

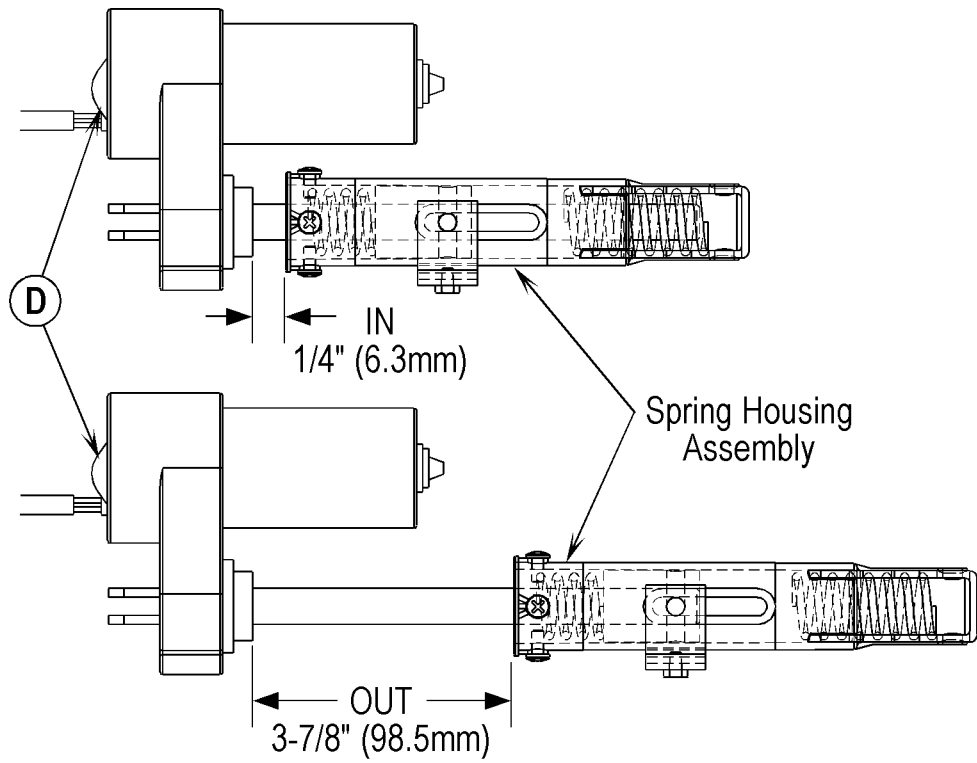
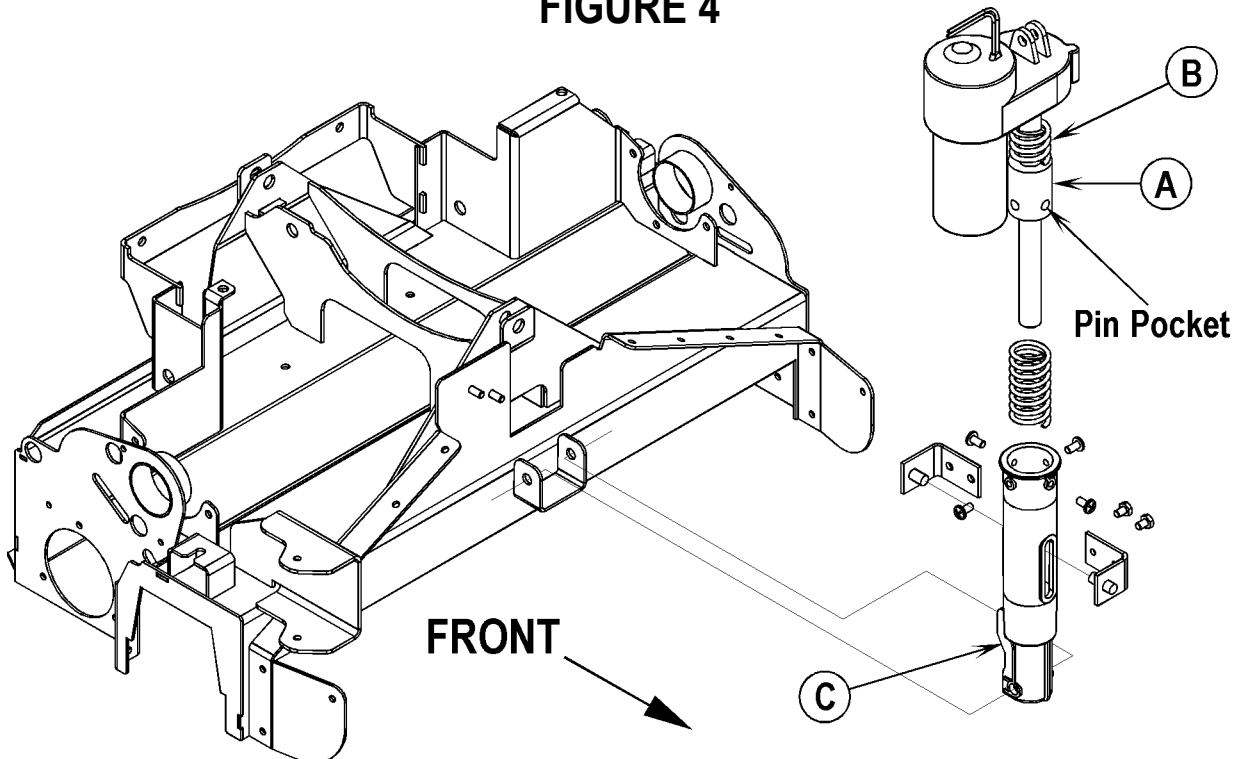

FIGURE 4



# ELECTRICAL SYSTEM

## CURTIS CONTROLLER DIAGNOSTICS

**Diagnostics Method A:** Uses the machine's control panel hourmeter display and wand switch indicator.

### FUNCTION OF THE SPEED CONTROLLER STATUS LIGHT AND DISPLAY

The Curtis 1228 speed control will output a fault code if there is a problem associated with the speed control and wheel drive system. See Figure 5. If a speed control fault occurs, the Hourmeter/Status display (G) will indicate "E03". When the E03 is being displayed and detects a fault the Green Indicator (H) normally the accessory wand indicator light will flash a special error code sequence until the fault is corrected. See "Table 1" for a description of the fault indications. **Service Note:** Instructions on how to read the error code status light. Example, OO O = two light flashes, a short pause. One flash, long pause and the code will be repeated. This indicates a fault code 2,1.

**FIGURE 5**

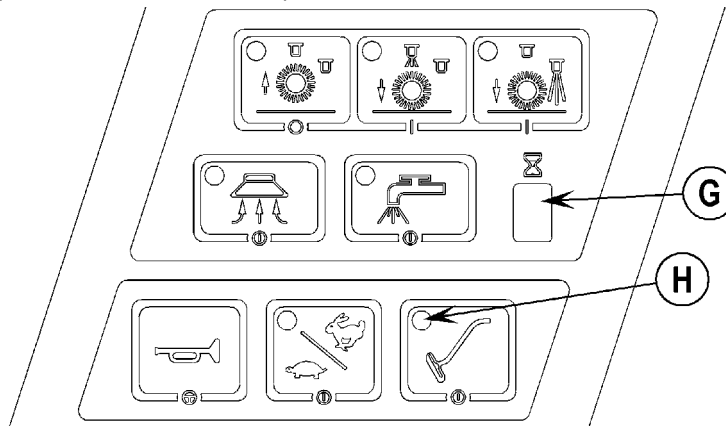

**Diagnostics Method B:** Uses the optional hand held Curtis programmer model 1307.

### PROGRAMMER DIAGNOSTICS

With a programmer, diagnostics and troubleshooting is more direct than with the LED alone. The programmer presents complete diagnostic information in plain language, no codes to decipher. Faults are displayed in the Diagnostic Menu, and the status of the controller inputs/outputs is displayed in the Test Menu.

The following 4-step process is generally used for diagnosing and troubleshooting an inoperative vehicle: (1) visually inspect the vehicle for obvious problems; (2) diagnose the problem, using the programmer; (3) test the circuitry with the programmer; and (4) correct the problem. Repeat the last three steps as necessary until the vehicle is operational.

Example: A vehicle that does not operate in "forward" is brought in for repair.

- 1 Examine the vehicle and its wiring for any obvious problems, such as broken wires or loose connections.
- 2 Connect the programmer, put it in diagnostic mode, and read the displayed fault information. In this example, the display shows "No Faults Present", indicating that the controller has not detected anything out of the norm.
- 3 Put the programmer in test mode, and observe the status of inputs and outputs in the forward direction. In this example, the display shows that the forward input did not activate when "forward" was selected, which means the problem is either in the electronic throttle or the throttle wiring.
- 4 Check or replace the electronic throttle and wiring and repeat the test. If the programmer shows the forward switch closing and the vehicle now drives normally, the problem has been corrected.

Refer to the Status Fault Codes (Table 1) for suggestions covering a wide range of possible faults.

### DIAGNOSTIC HISTORY

The handheld programmer can be used to access the controller's diagnostic history file. Connect the programmer, press the MORE INFO key, and then while continuing to hold the MORE INFO key, press the DIAGNOSTICS key. The programmer will read out all the faults that the controller has experienced since the last time the diagnostic history file was cleared. The faults may be intermittent faults, faults caused by loose wires, or faults caused by operator errors. Faults such as HPD or over temperature may be caused by operator habits or by overloading.

After a problem has been diagnosed and corrected, clearing the diagnostic history file is advisable. This allows the controller to accumulate a new file of faults. By checking the new diagnostic history file at a later date, you can readily determine whether the problem was indeed completely fixed.

To clear the diagnostic history file, go to the Special Program Menu (by pressing and holding the MORE INFO key, and then pressing the PROGRAM key), scroll through the menu until "Clear Diagnostic History" is the top line in the display, and then press MORE INFO again. The programmer will prompt you to acknowledge or cancel.

See the PROGRAMMER OPERATION section of this chapter for more detail on programmer operation.

# ELECTRICAL SYSTEM

STATUS LED FAULT CODES (TABLE 1)			
LED CODE	STATUS LIGHT DISPLAY	EXPLANATION	POSSIBLE CAUSE
1,1	0 0	over-/under-temperature cutback	1. Temperature >97°C (206°F) or < -25°C (-13°F). 2. Excessive load on vehicle. 3. Operation in extreme environments. 4. Electromagnetic, foot or parking brake not releasing properly.
1,2	0 00	throttle fault	1. Throttle input wire open or shorted. 2. Throttle pot defective. 3. Wrong throttle type selected.
1,3	0 000	speed limit pot fault	1. Speed limit pot wire(s) broken or shorted. 2. Broken speed limit pot.
1,4	0 0000	battery voltage too low	1. Battery voltage <17 volts. 2. Bad connection at battery or controller.
1,5	0 00000	battery voltage too high	1. Battery voltage >36 volts. 2. Vehicle operating with charger attached. 3. Intermittent battery connection.
2,1	00 0	main contactor driver Off fault	1. Main contactor driver failed open.
2,3	00 000	main contactor fault	1. Main contactor welded or stuck open. 2. Main contactor driver fault. 3. Brake coil resistance too high.
2,4	00 0000	main contactor driver On fault	1. Main contactor driver failed closed.
3,1	000 0	HPD fault present for >10 sec.	1. Misadjusted throttle. 2. Broken throttle pot or throttle mechanism.
3,2	000 00	brake On fault	1. Electromagnetic brake driver shorted. 2. Electromagnetic brake coil open.
3,3	000 000	precharge fault	1. Controller failure. 2. Low battery voltage.
3,4	000 0000	brake Off fault	1. Electromagnetic brake driver open. 2. Electromagnetic brake coil shorted.
3,5	000 00000	HPD (High Pedal Disable) fault	1. Improper sequence of throttle and KSI*, push, or inhibit inputs. 2. Misadjusted throttle pot
4,1	0000 0	current sense fault	1. Short in motor or in motor wiring. 2. Controller failure.
4,2	0000 00	motor voltage fault (hardware failsafe)	1. Motor voltage does not correspond to throttle request. 2. Short in motor or in motor wiring. 3. Controller failure.
4,3	0000 000	EEPROM fault	1. EEPROM failure or fault.
4,4	0000 0000	power section fault	1. EEPROM failure or fault. 2. Short in motor or in motor wiring. 3. Controller failure.

**\*NOTE:** A KSI (key switch input) system problem is a specific HPD (high pedal disable) type operational fault, caused by the operator activating the Fwd/Rev drive pedal before turning on the main key switch or activating the throttle before sitting on the seat. This can be cleared by returning the operator's drive pedal to neutral and cycling the key switch OFF and ON.

# ELECTRICAL SYSTEM

## INSTALLATION CHECKOUT FOR THE CURTIS SPEED CONTROLLER

### SAFETY!

The 1228 controller is inherently a high power device. When working around any battery powered vehicle, proper safety precautions should be taken. These include, but are not limited to: proper training, wearing eye protection, avoiding loose clothing and jewelry, and using insulated wrenches.

After installing a controller and before operating the vehicle, carefully complete the following checkout procedure. If you find a problem during the checkout, refer to the *DIAGNOSTICS* section of this chapter for further information.

The installation checkout can be conducted with or without the handheld programmer. The checkout procedure is easier with a programmer otherwise observe the Status LED for codes (located on operator panel wand indicator light). The part number of the handheld programmer is **56409441**. **NOTE:** If you have a programmer with a serial number before 2100 you will need to update your programmer. A free upgrade kit is available, order part number **56409822**. Also a different quad 4 pin programmer cable (PN **56409823**) is needed to link the programmer to the controller plug-in port.

### WARNING!

Put the vehicle up on blocks to get the drive wheel off the ground before beginning these tests.

Turn the key switch off and make sure that the seat switch is open, and the throttle is in neutral.

Do not stand, or allow anyone else to stand, directly in front of or behind the vehicle during the tests.

- 1 Remove electrical panel to access controller then observe LED status light on touch pad operator panel wand indicator light. If a programmer is available, connect it to the programmer plug-in port.
- 2 Sit on the seat and turn the key switch on. The programmer should “power up” with an initial display. If neither happens, check for continuity in the key switch circuit and controller ground.
- 3 If you are using a programmer, put it into the diagnostic mode by pressing the *DIAGNOSTICS* key. The display should indicate “No Faults Found”. Note: Before pressing the diagnostics key, wait until model # screen appears, if the throttle is activated prior to this screen appearing the controller will shut down.
  - If there is a problem, the LED will flash a diagnostic code and the programmer will display a diagnostic message. If you are conducting the checkout without a programmer, look up the LED diagnostic code in the *DIAGNOSTICS* section of this chapter (**Table 1**).
  - When the problem has been corrected, it may be necessary to cycle the key or seat switch to clear the fault code.
- 4 While sitting on the seat, operate the throttle. The motor should begin to turn in the selected direction. If it does not, verify the wiring to the controller, and the motor. The motor should run proportionally faster with increasing throttle. If not, refer to the *DIAGNOSTICS* section of this chapter (**Table 1**).
- 5 If you are using a programmer, put it into the test mode by pressing the *TEST* key. Scroll down to observe the status of the forward, reverse and brake switch. Cycle each switch in turn, observing the programmer. Each input should show the correct state on the programmer.
- 6 Take the vehicle off the blocks and drive it in an open area. It should have smooth acceleration and good top speed.

## PROGRAMMING VEHICLE SPEED CHANGES

The maximum high-speed M1 (transport) and maximum low speed M2 (scrub) can be changed electronically, using the handheld programmer. To change a parameter using the programmer, press the PROGRAM key, and scroll down the Program Menu until the desired parameter is the top line of the display. Press the appropriate CHANGE VALUE key ("up" or "down") until the desired number is reached. The parameter is now set at the desired value. All programming occurs in real time. In other words, the parameters can be changed while the vehicle is in operation.

The upper and lower limits of parameters are set at the factory. Some parameters have dependencies on other parameters. When the programmer is being used to adjust a parameter and a limit is reached, the display will stop changing. To see why the display has stopped changing, press the MORE INFO key. If the limit is related to another parameter, that information will be displayed; changing the value of the related parameter may allow the original parameter to be adjusted further. Otherwise, the display simply says "Max Limit" or "Min Limit."

Use of the programmer is described more fully in the *PROGRAMMER OPERATION* section of this chapter.

## MAINTENANCE

There are no user-serviceable parts inside the Curtis PMC 1228 controller. No attempt should be made to open the controller. Opening the controller may damage it and will void the warranty.

However, it is recommended that the controller exterior be cleaned periodically, and if a handheld programmer is available, this periodic cleaning provides a good opportunity to check the controller's diagnostic history file.

## HANDHELD PROGRAMMER USE

Optional Curtis handheld programmer allows you to program, test and diagnose Curtis controllers. Use of a handheld programmer is described more fully in the CURTIS PROGRAMMER MANUAL 56043101.

# ELECTRICAL SYSTEM

## FUNCTIONAL OVERVIEW OF MAIN CONTROL BOARD

The primary function of the main control board E1 is to position the scrubbing brush(s) with respect to the floor surface using a lift actuator motor to maintain the correct brush pressure and current draw of the brush motor(s). When either the maintenance or restoration scrub mode switch is depressed this will lower the scrub deck to the operating position and by activating the foot pedal start the brush motor. The controller is continuously monitoring the current to the brush motor and when it senses a current draw out of the desired range it automatically raises or lowers the brush deck by turning on the brush actuator motor. This process is repeated until the brush motor is shut off. The controller also manages the other supportive systems such as the extract deck in reverse lift, solution on/off, and vacuum motor. Note: See the Know Your Machine system in this manual for a complete explanation of the machine's operation.

The secondary function of the main control is to detect any system failures and display an error code on the hour meter display or store it in the main control board's recall memory mode. The error code(s) are used to help the serviceperson determine the fault and to quickly guide in repairing a specific system malfunction. Note: See the *Troubleshooting Guide* for further information.

An additional special feature of the main control board is to change program settings for a set of specific machine functions. See the *Main Control Board Special Program Options* section in this manual for further information.

## TROUBLESHOOTING GUIDE

Any error codes detected by main control board will be displayed on the hour meter LED display as they occur. If more than one-error exists the display will sequence through the error codes at one-second intervals. The error display will show on the hour meter as the letter E followed by a two-digit code. EX: E03 would be a drive system fault. **When troubleshooting any "Fault Description" noted with a double asterisk (\*\*) follow the instructions for temporarily disabling the control boards special fault detection program.** See the *Main Control Board Special Program Options* section in this manual.

## MAIN CONTROLLER ERROR CODES

Error Code	Fault Description	Troubleshooting Action
E03	Drive system fault	1. Check for a tripped drive motor circuit breaker (45 amp). Investigate reason for possible mechanical over load. Examples: sticking brakes, parking brake not released, prolonged ramp climbing. 2. Observe the green flashing wand indicator light (location operator panel) then see Curtis drive motor controller section to further troubleshoot the drive system ( <b>Table 1</b> ).
E04	Scrub deck lift actuator overload normal current load 1 - 2.5 Amps max. current load 6 Amps max. current no load 1.4 Amps	1. Check for binding or frozen brush lift linkage and excessive weight on brush deck. 2. Check for short circuit* in brush motor and wiring. Repair or replace.
E06	Scrub motor overload	1. Check for binding in rotation of brushes or improper brush lift actuator operation. 2. Check the negative supply cable at the brush motor for a wiring problem or improper modifications and also the small YEL/VIO current sense wire. 3. Check to see that the proper "Scrub Deck Motor Type" is selected*** (extract or sweep extract). 4. Check for short circuit* in brush motor or wiring. 5. Check excessive belt tension and idler bearing.
E07	Vacuum motor overload Normal current load 17-19 Amps (1 motor). Normal current load 34-38 Amps (2 motors)	1. Check for debris in vac motor. 2. Worn carbon brushes. 3. Defective motor bearings. 4. Check for short circuit* in vac motor or wiring. Repair or replace.

\*\*\* See the *Main Control Board Special Program Options* section to activate the "Scrub Deck Motor Type" Selection function.

# ELECTRICAL SYSTEM

## MAIN CONTROLLER ERROR CODES (CONTINUED)

Error Code	Fault Description	Troubleshooting Action
E08	Solution solenoid overload	1. Check for a wiring problem. 2. Check coil resistance (spec. is 185 Ohms + or – 15%). Replace solution solenoid if lower than 157 Ohms.
E17	Scrub deck lift actuator circuit open (**)	1. Check for disconnected actuator wiring, open in wiring or defective actuator motor. Repair or replace. 2. Check controller output voltage should be 36V if 0V controller failure (replace).
E18	Scrub deck lift actuator short	1. Check for binding or frozen brush lift linkage and excessive weight on brush deck. 2. Check for short circuit* in brush lift motor and wiring. Repair or replace.
E21	Scrub motor circuit open (**)	1. Check for open in brush motor wiring or defective motor. 2. Check the negative supply cable at the brush motor for a wiring problem or improper modifications (this is a special cable and must be replaced with the original OEM). 3. Check resistance on brush motor solenoid. Nominal resistance specs are: • K1 - <i>White-Rodgers</i> brand = 120 Ohms • K1 - <i>Ametek</i> ® brand = 102 Ohms If the resistance is less than 20% from spec, replace the solenoid. 4. Check if brushes are installed.
E22	Scrub motor short	Same as E06.
E23	Vacuum motor circuit open (**)	1. Check for disconnected vacuum motor wiring, open in wiring and defective vacuum motor. Repair or replace. 2. Check resistance on vac motor solenoid. Nominal resistance specs are: • K2 - <i>White-Rodgers</i> brand = 120 Ohms • K2 - <i>Ametek</i> ® brand = 98.5 Ohms If the resistance is less than 20% from spec, replace the solenoid. 3. Check controller output voltage should be 36V if 0V controller failure (replace).
E24	Vacuum motor short	Same as E07
E25	Solution solenoid circuit open (**)	1. Check for disconnected solenoid wiring plug, open in wiring or defective solenoid. Repair or replace. 2. Check controller output voltage should be 36V if 0V controller failure (replace).
E26	Coil / solution solenoid short	1. Check for a short circuit* in wiring or solenoid coil. Repair or replace.
E27	No accessory / wiring	1. Loss of battery (pos.) output to all system contactors (brush, solution solenoid and vacuum) and system accessories (headlight, warning beacon, solution pump). 2. Check controller accessory terminal output (J2-8 Wht/Brn wire) voltage should be 36V if 0V controller failure (replace).

\*Short Circuit definition:

- A short circuit is a parallel path of very low resistance, often caused accidentally.
- With low resistance there is an excessive amount of current.
- The excessive current will either melt the wires or open a fusible link.

# ELECTRICAL SYSTEM

## SERVICE TEST MODE:

To assist in the troubleshooting and servicing of the electrical system and related components on the BRX 700 extractors, a special test mode which allows independent control of the various outputs and monitoring of the various inputs has been incorporated.

To enter the service test mode perform the following steps:

- 1 Turn the **main power key switch** to the **off** position.
- 2 Press and hold the Wand Switch (I).
- 3 While holding the wand switch turn the main power key switch to the on position.
- 4 Continue to hold the wand switch until the status display indicates "t" for test mode.
- 5 Release the wand switch.
- 6 The function of each switch and indicator is described in the following pages.
- 7 To exit this mode, turn the main power key switch to the off position.

## CONTROL PANEL

- |   |                                  |    |   |
|---|----------------------------------|----|---|
| A | Scrub OFF Indicator              | K1 | Battery Condition Indicator (RED)         |
| B | Scrub OFF Switch                 | K2 | Battery Condition Indicator (YELLOW)      |
| C | Maintenance Mode Indicator       | K3 | Battery Condition Indicator (GREEN)       |
| D | Maintenance Mode Switch          | L  | Speed Select Switch (extract / transport) |
| E | Restoration Mode Indicator       | M  | Speed Select Indicator                    |
| F | Restoration Mode Switch          | N  | Horn Switch                               |
| G | Hourmeter Display                | O  | Vacuum Switch                             |
| H | Accessory Vacuum Indicator       | P  | Vacuum System Indicator                   |
| I | Accessory Vacuum ON / OFF Switch | Q  | Solution System Indicator                 |
| J | Key Switch / Main Power          | R  | Solution Switch                           |
| K | Battery Condition Indicators     |    |   |

FIGURE 9

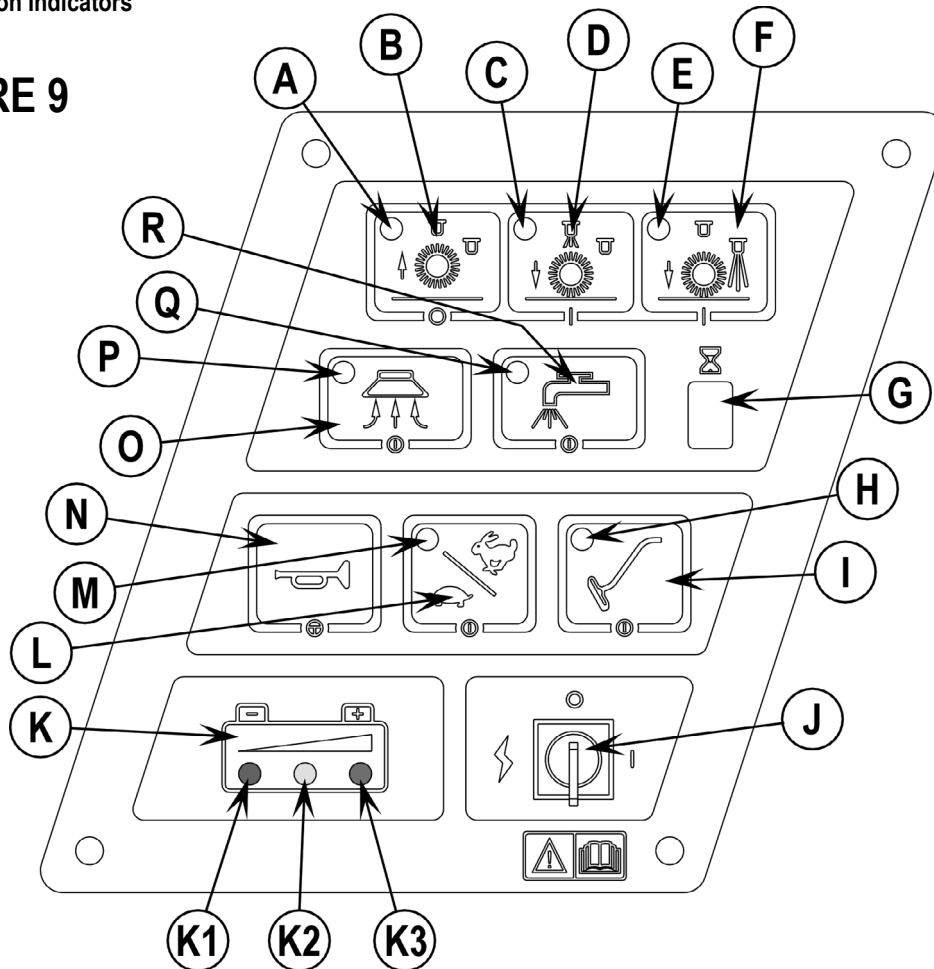

## SERVICE TEST MODE (CONTINUED)

### Input Indicators:

See Figure 9 for button locations. Note: the seat switch must be closed for any of the following three indicators to be lit.

#### **Battery status red indicator (K1):**

Speed control reverse signal. This indicator will be lit if the reverse signal from the speed control is active.

#### **Battery status yellow indicator (K2):**

Speed control forward/reverse signal. This indicator will be lit if the forward/reverse signal from the speed control is active.

#### **Battery status green indicator (K3):**

Speed control status signal. This indicator will be lit if the status signal from the speed control is active. If a speed control fault exists, this indicator will flash the fault code from the speed control. Refer to the speed control section for details on these codes.

### Status Display (G):

If no over-current faults are present, the status display will show the battery voltage. This display is accurate to within +/- 0.15 volts. Therefore, the voltage displayed may not correlate precisely to a high-accuracy, calibrated voltmeter.

- An example of how 36.0 volts would be displayed is as follows:
- The display will show "3" followed by a brief blank period
- The display will show "6" followed by a brief blank period
- The display will show "." followed by a brief blank period (serves as decimal point)
- The display will show "0" followed by a long blank period
- The above sequence will repeat

If over-current faults are present, the status display will indicate the error codes.

### Output Controls:

See Figure 9. The control panel switches are used to control various output functions of the main control unit. Below is a list of each switch and the function it controls. Following the list is a detailed description of each function.

Scrub off switch (**B**): Controls brush motor(s).

Maintenance mode switch (**D**): Controls scrub deck lift actuator.

Restore mode switch (**E**): If this switch is pressed, the restore mode indicator will illuminate.

Vacuum switch (**O**): Controls vacuum motor(s).

Solution switch (**R**): Controls solution solenoids.

Horn switch (**N**): Used to jog the actuator.

Fast/Slow switch (**L**): Selects the various speed control speed limits.

Wand switch (**I**): If this switch is pressed the wand indicator will illuminate.

#### **Scrub System Off Switch (B):**

This switch is used to toggle the state of the brush motor. Pressing and releasing this switch will alternately turn the brush motor(s) on and off. The indicator provides the following status information:

**Off** - Brush motor output is off and there is no brush motor current sensed.

**Steady Green** - Brush motor output is on and there is normal brush motor current sensed.

**Brief On Green Flash** - Brush motor output is off and brush motor current is being sensed (abnormal condition).

**Brief Off Green Flash** - Brush motor output is on and brush motor current is not being sensed (abnormal condition).

**Flashing Red** - Brush motor overload has occurred.

# ELECTRICAL SYSTEM

## SERVICE TEST MODE (CONTINUED)

### Maintenance mode Switch (D):

This switch is used to control the output to the scrub deck lift actuator. Pressing and releasing this switch will cycle the actuator output through 4 states. These are:

- 1 - output off, direction = up
- 2 - output on, direction = down
- 3 - output off, direction = down
- 4 - output on, direction = up

When the output is in state 1, the actuator output is turned off. The maintenance mode indicator should be off. If the indicator is flashing green, this indicates that the control is sensing current flow through the actuator (shorted output driver, control error). If the maintenance mode switch was the last switch pressed, it is possible to momentarily activate the actuator output using the horn switch. This can be used to jog the actuator to allow precise positioning of the actuator. NOTE: the actuator can only move in this situation if it is not at its up limit.

When the output is in state 2, the actuator output is turned on. The maintenance mode indicator should be green or flashing green. The indicator will be a steady green if the control senses current flow through the actuator. It will flash green if no actuator current flow is sensed (actuator at limit, open circuit, open output driver). The horn switch has no effect in this state.

When the output is in state 3, the actuator output is turned off. The maintenance mode indicator should be off. If the indicator is flashing green, this indicates that the control is sensing current flow through the actuator (shorted output driver, control error). If the maintenance mode switch was the last switch pressed, it is possible to momentarily activate the actuator output using the horn switch. This can be used to jog the actuator to allow precise positioning of the actuator. NOTE: the actuator can only move in this situation if it is not at its down limit.

When the output is in state 4, the actuator output is turned on. The maintenance mode indicator should be green or flashing green. The indicator will be a steady green if the control senses current flow through the actuator. It will flash green if no actuator current flow is sensed (actuator at limit, open circuit, open output driver). The horn switch has no effect in this state.

### Restore Mode Switch (E):

This switch does not control any output functions. Pressing this switch will illuminate the restore mode indicator.

### Vacuum Switch (Q):

This switch is used to toggle the state of the vacuum motor. Pressing and releasing this switch will alternately turn the vacuum motor on and off. The indicator (P) provides the following status information:

**Off** - Vacuum motor output is off and there is no vacuum motor current sensed.

**Steady Green** - Vacuum output is on and there is normal vacuum motor current sensed.

**Brief On Green Flash** - Vacuum motor output is off and vacuum motor current is being sensed (abnormal condition).

**Brief Off Green Flash** - Vacuum motor output is on and vacuum motor current is not being sensed (abnormal condition).

**Flashing Red** - Vacuum motor overload has occurred.

## SERVICE TEST MODE (CONTINUED)

### **Solution Switch (R):**

This switch is used to toggle the state of the solution solenoids. Pressing and releasing this switch will alternately turn the solution solenoids on and off. The indicator (**Q**) provides the following status information:

**Off** - Solenoid output is off.

**Green** - Solenoid output is on.

**Flashing Red** – Solution solenoid / contactor coil overload has occurred.

### **Horn Switch (N):**

This switch is used to momentarily activate the scrub deck lift actuator. See the descriptions above for more details.

### **Fast / Slow Switch (L):**

This switch is used to toggle the state of the multimode output to the speed control. This is used to select which speed limit the speed control uses. Pressing and releasing this switch will alternately turn the multimode output on and off. The indicator (**M**) provides the following status information:

**Steady Green** – Speed control mode 1 is selected (transport speed).

**Brief Off Green Flash** – Speed control mode 2 is selected (scrub speed).

### **Wand Switch (I):**

This switch does not control any output functions. Pressing this switch will illuminate the wand indicator.

# ELECTRICAL SYSTEM

## MAIN CONTROL BOARD SPECIAL PROGRAM OPTIONS

### Displaying the Control Unit Revision Level:

If it is desired to view the revision level of the control unit perform the following steps:

- 1 Turn the **main power key switch** to the **off** position.
- 2 Press and hold the scrub system off switch and the fast/slow switch.
- 3 While holding both switches turn the main power key switch to the on position.
- 4 Continue to hold both switches until the fast/slow indicator is flashing.
- 5 Release both switches.
- 6 The status display will now indicate the revision level of the control unit. The displayed value will be a letter from A to Z.
- 7 To exit this mode, turn the main power key switch to the off position.

### Selection of Low Voltage Cutout Threshold:

FACTORY DEFAULT: S (STANDARD)

The BRX 700 is equipped with a low voltage cutout feature to prevent over-discharging the batteries. This feature will automatically shut down the scrub system when the battery voltage falls to the selected threshold. The cutout level is adjustable. The *standard* setting is 31 volts (1.72 volts per cell) and the *alternate* setting is 32.5 volts (1.81 volts per cell). Select the proper cutout level based on the battery manufacturer's specifications. *It is important to note that some maintenance free batteries (including some gelled electrolyte cells) are capable of being safely discharged down to 1.72 volts per cell.* To select between the two cutout levels:

- 1 Turn the **main power key switch** to the **off** position.
- 2 Press and hold the **scrub system off switch**.
- 3 While holding the scrub system off switch turn the **main power key switch** to the **on** position.
- 4 Continue to hold the scrub system off switch until the scrub off indicator turns green.
- 5 Release the scrub off switch.
- 6 The status display will now show "S" or "A". Pressing and releasing the **scrub off switch** will now select between the two options. For the standard cutout level, select "S". For the alternate cutout level, select "A".
- 7 To save the new setting, turn the **main power key switch** to the **off** position.
- 8 The new setting will be saved and will remain in effect until it is changed again.

### Selection of Scrub Switch Operation and Scrub Pressure Limits:

FACTORY DEFAULT: MODE = 0 (FIXED PRESSURE MODE), MAINTENANCE SCRUB PRESSURE = 3, RESTORE SCRUB PRESSURE = 8

The scrub brush pressure on the BRX 700 can be adjusted to compensate for different brush and/or carpet types. The maintenance mode settings are 1 to 5 and the restore mode settings are 6 to 9. For each mode (maintenance or restore) the values represent a relative load on the motors with the small numbers (1 & 6) being the least load and the larger numbers (4 & 9) being the greatest load. A setting of 1 for the maintenance mode and 6 for the restore mode will provide an equal load for the motors. The same is true for settings 2 & 7, 3 & 8, and 4 & 9. NOTE: 4 & 5 provide the same load for the maintenance mode.

#### Fixed Pressure Mode

- 1 Turn the **main power key switch** to the **off** position.
- 2 Press and hold the **maintenance mode switch**.
- 3 While holding the maintenance mode switch turn the **main power key switch** to the **on** position.
- 4 Continue to hold the maintenance mode switch until the maintenance mode indicator is green.
- 5 Release the maintenance mode switch.
- 6 Press the **scrub system off switch** to proceed to the pressure adjustment operation.
- 7 The status display will now show a number from 1 to 5. This represents the maintenance mode scrub pressure. Use the **maintenance mode switch** to set the desired pressure.
- 8 Press the **scrub system off switch** to save this setting.
- 9 The status display will now show a number from (1 + the setting from step 7) to 9. This represents the restore mode scrub pressure. The restore mode indicator will now be illuminated. Use the **restore mode switch** to set the desired pressure.
- 10 Press the **scrub system off switch** to save this setting.
- 11 The status display will now show "d" to indicate that the procedure is done.
- 12 The new setting will be saved and will remain in effect until it is changed again.

## SPECIAL PROGRAM OPTIONS (CONTINUED)

SCRUB PRESSURE & CURRENT LOAD (AMPS) SPECIFICATIONS (TABLE 2)									
Scrub Pressure	1	2	3*	4	5	6	7	8**	9
AquaRide (one) 3/4 HP	12	15	15	15	15	12	15	15	15
AquaRideSE BRX 700 (two) 3/4 HP	15	20	25	30	30	15	20	25	30
*Default setting for maintenance mode					**Default setting for restoration mode				

### Restoring the scrub modes and pressures to factory default settings:

FACTORY DEFAULT: MODE = 0 (FIXED PRESSURE MODE), MAINTENANCE SCRUB PRESSURE = 3, RESTORE SCRUB PRESSURE = 8

If it is desired to restore the scrub switch operating mode and pressure limit to the default setting, perform the following steps:

- 1 Turn the **main power key switch** to the **off** position.
- 2 Press and hold the **restore mode switch**.
- 3 While holding the restore mode switch turn the **main power key switch** to the **on** position.
- 4 Continue to hold the restore mode switch until the restore mode indicator is green.
- 5 Release the restore mode switch. The status display will now indicate "d" for done.
- 6 The scrub switch operating mode and pressure settings have now been restored.
- 7 Turn the **main power key switch** to the **off** position.

### Turning the Automatic Vacuum Shutoff Option On or Off:

FACTORY DEFAULT: ON

The BRX 700 is equipped with a feature that will automatically shut off the vacuum and scrub systems and display "FULL" on the status display if the recovery tank becomes filled. If problems are encountered with the vacuum automatic shutoff feature, such as the vacuum shutting off even if the recovery tank is not full, this feature can be turned off (see also, vacuum auto-shutoff threshold adjustment). To turn this feature on or off perform the following steps:

- 1 Turn the **main power key switch** to the **off** position.
- 2 Press and hold the **vacuum switch**.
- 3 While holding the vacuum switch turn the **main power key switch** to the **on** position.
- 4 Continue to hold the vacuum switch until the vacuum indicator is green.
- 5 Release the vacuum switch. The status display will now indicate "E" or "d".
- 6 Pressing and releasing the **vacuum switch** will now select between "E" for enabled or "d" for disabled. Enabled means that the automatic shutoff feature is turned on, disabled means that the automatic shutoff feature is turned off.
- 7 To save the new setting, turn the **main power key switch** to the **off** position.
- 8 The new setting will be saved and will remain in effect until it is changed again.

# ELECTRICAL SYSTEM

## SPECIAL PROGRAM OPTIONS (CONTINUED)

### Vacuum Automatic Shut-off Threshold Adjustment:

FACTORY DEFAULT: 4

The sensitivity of the automatic vacuum shut-off feature can be adjusted if necessary. This adjustment sets the amount of change required in the vacuum power consumption to cause the control unit to indicate a full recovery tank condition. The setting is adjustable from 0 to 9. 0 is the minimum sensitivity, 9 is the maximum sensitivity. If the unit falsely indicates a tank full condition, try setting this parameter to a lower value. If the control unit fails to shut the vacuum system off when the recovery tank float ball plugs the vacuum inlet, try setting this parameter to a higher value. To adjust the vacuum shut-off sensitivity perform the following steps:

- 1 Turn the **main power key switch** to the **off** position.
- 2 Press and hold the **maintenance mode** and the **solution switch**.
- 3 While holding both switches turn the **main power key switch** to the **on** position.
- 4 Continue to hold both switches until the solution indicator is flashing yellow.
- 5 Release both switches. The status display will now indicate a number from 0 to 9 depending on the threshold setting.
- 6 Pressing and releasing the **solution switch** will now select the threshold level. The level will increment from 0 to 9. 0 = minimum sensitivity, 9 = maximum sensitivity.
- 7 To save the new setting, turn the **main power key switch** to the **off** position.
- 8 The new setting will be saved and will remain in effect until it is changed again.

### Recall Of Stored Error Codes:

Whenever an electrical system fault is detected by the main control unit, one or more error codes are displayed and stored by the control unit. If it is desired, the error code (if any) from the previous operation of the machine can be recalled for troubleshooting purposes. To recall the last stored error codes perform the following steps:

- 1 Turn the **main power key switch** to the **off** position.
- 2 Press and hold the **solution switch**.
- 3 While holding the solution switch, turn the **main power key switch** to the **on** position.
- 4 Continue to hold the solution switch until the solution indicator is green.
- 5 Release the solution switch.
- 6 If there were previously no error codes stored, the display will now show "-". Go to step 11.
- 7 If error codes were stored, the display will now show the stored code(s) and the scrub system off indicator will now be red. An example of how two codes, 6 and 18, would be displayed is as follows:
  - The display will show "E" followed by a brief blank period
  - The display will show "0" followed by a brief blank period
  - The display will show "6" followed by a slightly longer blank period
  - The display will show "E" followed by a brief blank period
  - The display will show "1" followed by a brief blank period
  - The display will show "8" followed by a long blank period
  - The above sequence will repeat
- 8 To pause the display, press and hold the **solution switch**.
- 9 To clear the stored codes press and release the **scrub system off** switch. The display will now show "-". Go to step 11.
- 10 If it is desired to save the codes, go to step 11.
- 11 To exit the error code recall mode, turn the **main power key switch** to the **off** position.

## SPECIAL PROGRAM OPTIONS (CONTINUED)

### Turning Fault Detection On or Off:

FACTORY DEFAULT: ON

Normally, the main control unit will perform checks of the electrical system during operation. If a fault occurs in a particular system that system (and possibly others) will be shut down. This can make troubleshooting the system difficult. This option will allow service personnel to disable some of the fault detection checks to facilitate troubleshooting. This will *not* disable the over-current protection on any of the systems. To turn the fault checking on or off:

- 1 Turn the **main power key switch** to the **off** position.
- 2 Press and hold the **scrub system off switch** and the **solution switch**.
- 3 While holding both switches turn the **main power key switch** to the **on** position.
- 4 Continue to hold both switches until the solution indicator is yellow.
- 5 Release both switches. The status display will now indicate "E" or "d".
- 6 Pressing and releasing the **solution switch** will now select between "E" for enabled or "d" for disabled. Enabled means that the fault checking is turned on, disabled means that the fault checking is turned off.
- 7 To save the new setting turn the **main power key switch** to the **off** position.
- 8 The new setting will be saved and will remain in effect until it is changed again.

### Turning the High Speed Scrub Option On or Off:

FACTORY DEFAULT: ON

The control system on the BRX 700 is programmed to limit the maximum speed while scrubbing to a value less than that allowed for driving when not scrubbing. The speed select switch on the control panel will override this speed limit feature and allow scrubbing at a higher rate of speed. If it is desired to prevent scrubbing at this faster speed the fast/slow feature can be turned off. To turn this feature on or off perform the following steps:

- 1 Turn the **main power key switch** to the **off** position.
- 2 Press and hold the **fast/slow switch**.
- 3 While holding the fast/slow switch turn the **main power key switch** to the **on** position.
- 4 Continue to hold the fast/slow switch until the fast/slow indicator is green.
- 5 Release the fast/slow switch. The status display will now indicate "E" or "d"
- 6 Pressing and releasing the **fast/slow switch** will now select between "E" for enabled or "d" for disabled. Enabled means that the high speed scrub feature is turned on, disabled means that the high speed scrub feature is turned off.
- 7 To save the new setting, turn the **main power key switch** to the **off** position.
- 8 The new setting will be saved and will remain in effect until it is changed again.

### Scrub Deck Motor Type Selection:

FACTORY DEFAULT: MODE = E (EXTRACTOR), MOTOR TYPE: 1 IF EXTRACT ONLY DECK, 2 IF SWEEP EXTRACT DECK.

The BRX 700 can be equipped with two different scrub deck options. This function configures the control unit current settings for each of the scrub deck types. **Improper setting of the motor type may result in motor damage due to overloading.** To select the proper scrub deck motor type:

- 1 Turn the **main power key switch** to the **off** position.
- 2 Press and hold the **scrub system off** and **restore mode switches**.
- 3 While holding both switches turn the **main power key switch** to the **on** position.
- 4 Continue to hold both switches until the restore mode indicator is yellow.
- 5 Release both switches. The status display will now indicate "S" or "E".
- 6 Pressing and releasing the **restore mode switch** will now select between "S" for scrubber and "E" for extractor. **Make sure that "E" is displayed.**
- 7 Press the **scrub system off switch** to save this setting
- 8 The status display will now display "1", or "2". Pressing the **restore mode switch** will now select between the two settings. Select "1" if the machine is equipped with an extract-only deck. Select "2" if the machine is equipped with a sweep-extract deck.
- 9 Once the proper setting is displayed, press the **scrub system off switch** to save this setting.
- 10 The status display will now display "d" to indicate that the operation is done.
- 11 Turn the **main power key switch** to the **off** position.

# ELECTRICAL SYSTEM

## SPECIAL PROGRAM OPTIONS (CONTINUED)

### Single or Dual Vacuum Motor Selection:

FACTORY DEFAULT: 2 (DUAL VACUUM MOTORS)

The BRX 700 comes with standard dual vacuum motors. If for some reason it is desired to use only one vacuum motor, the control must be programmed accordingly to provide the proper overcurrent protection for the vacuum motor. To program the control for the number of vacuum motors perform the following steps:

- 1 Turn the **main power key switch** to the **off** position.
- 2 Press and hold the **scrub system off** and **vacuum switches**.
- 3 While holding both switches turn the **main power key switch** to the **on** position.
- 4 Continue to hold both switches until the vacuum indicator is yellow.
- 5 Release both switches. The status display will now indicate "1" or "2".
- 6 Pressing and releasing the **vacuum** switch will now select between "1" for a single vacuum motor or "2" for dual vacuum motors.
- 7 To save the new setting turn the **main power key switch** to the **off** position.
- 8 The new setting will be saved and will remain in effect until it is changed again.

### Control Unit Sleep Delay Period:

FACTORY DEFAULT: 1 (10 MINUTES)

If the BRX 700 is left in an idle state for a period determined by the sleep delay setting the control unit will automatically raise the scrub deck and turn off any accessories. This is to conserve battery power. The sleep period is adjustable from 10 to 90 minutes in 10 minute increments. It can also be turned off. To change the sleep delay period perform the following steps:

- 1 Turn the **main power key switch** to the **off** position.
- 2 Press and hold the **scrub system off** and the **wand switch**.
- 3 While holding both switches turn the **main power key switch** to the **on** position.
- 4 Continue to hold both switches until the wand indicator is flashing.
- 5 Release both switches. The status display will now indicate a number from 0 to 9 depending on the current sleep delay period.
- 6 Pressing and releasing the **wand switch** will now select the delay period. The level will increment from 0 to 9; 0 = off (sleep disabled), 1 = 10 minutes, 2 = 20 minutes, ... up to 9 = 90 minutes.
- 7 To save the new setting, turn the **main power key switch** to the **off** position.
- 8 The new setting will be saved and will remain in effect until it is changed again.

### Turning the Extract Deck Raise-In-Reverse Option On or Off:

FACTORY DEFAULT: ON

To prevent chattering of the extractor pick-up shoes while backing up, the scrub deck will automatically raise to the up position. If it is desired to allow the scrub deck to remain down while backing up, this option may be turned off. To turn this option on or off, perform the following steps:

- 1 Turn the **main power key switch** to the **off** position.
- 2 Press and hold the **scrub system off** and **maintenance mode switches**.
- 3 While holding both switches turn the **main power key switch** to the **on** position.
- 4 Continue to hold both switches until the maintenance mode indicator is yellow.
- 5 Release both switches. The status display will now indicate "E" or "d".
- 6 Pressing and releasing the **maintenance mode** switch will now select between "E" for enabled or "d" for disabled. Enabled means that the option is turned on (deck will rise in reverse), disabled means that the option is turned off (deck will stay down in reverse).
- 7 To save the new setting, turn the **main power key switch** to the **off** position.
- 8 The new setting will be saved and will remain in effect until it is changed again.

## SPECIAL PROGRAM OPTIONS (CONTINUED)

### Back-up Alarm Volume Control:

FACTORY DEFAULT: 0 (OFF)

The BRX 700 is equipped with an audible warning device which functions as a horn, a back-up alarm, and a forward annunciator. The volume of the back-up alarm can be adjusted to one of ten settings. 1 is the minimum setting and 9 is the maximum setting, 0 is off. To change the back-up alarm volume perform the following steps:

- 1 Turn the **main power key switch** to the **off** position.
- 2 Press and hold the **horn switch**.
- 3 While holding the horn switch turn the **main power key switch** to the **on** position.
- 4 Continue to hold the horn switch until the red battery status indicator is lit and the status display shows a number from 0 to 9 depending on the current volume setting.
- 5 Release the horn switch.
- 6 Pressing and releasing the **horn switch** will now select the volume level. The level will increment from 0 to 9, 9 being the loudest. To hear the back-up alarm volume select the reverse direction by pressing lightly on the throttle.
- 7 To save the new setting, turn the **main power key switch** to the **off** position.
- 8 The new setting will be saved and will remain in effect until it is changed again.

### Forward Annunciator Volume Control:

FACTORY DEFAULT: 0 (OFF)

The BRX 700 is equipped with an audible warning device which functions as a horn, a back-up alarm, and a forward annunciator. The volume of the forward annunciator can be adjusted to one of ten settings. 1 is the minimum setting and 9 is the maximum setting, 0 is off. To change the forward annunciator volume, perform the following steps:

- 1 Turn the **main power key switch** to the **off** position.
- 2 Press and hold the **scrub system off** and the **horn switch**.
- 3 While holding both switches turn the **main power key switch** to the **on** position.
- 4 Continue to hold both switches until the green battery status indicator is lit and the status display shows a number from 0 to 9 depending on the current volume setting.
- 5 Release the horn switch.
- 6 Pressing and releasing the **horn switch** will now select the volume level. The level will increment from 0 to 9, 9 being the loudest. To hear the forward annunciator volume select the forward direction by pressing lightly on the throttle.
- 7 To save the new setting, turn the **main power key switch** to the **off** position.
- 8 The new setting will be saved and will remain in effect until it is changed again.

# ELECTRICAL SYSTEM

## Drive Motor Breakdown

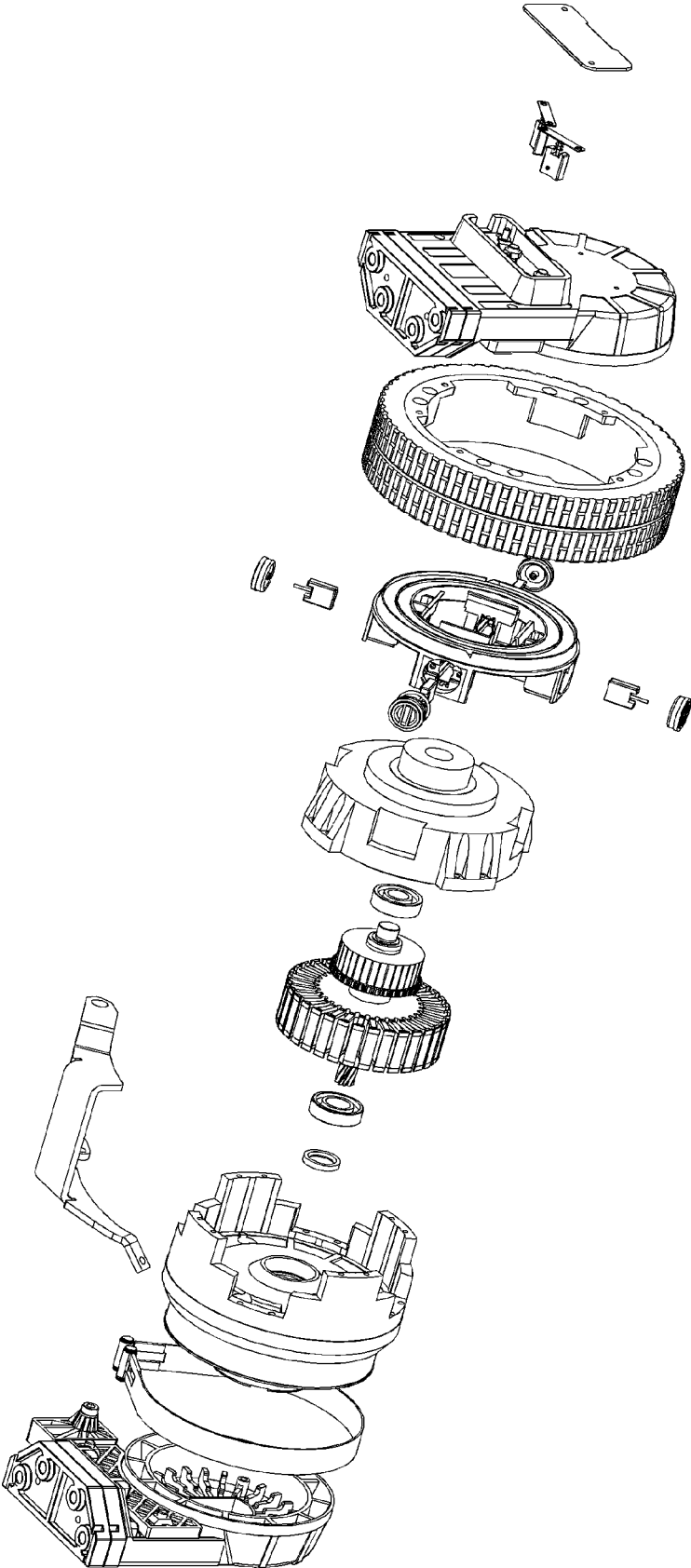

For Machines before Serial Number 1839732

# ELECTRICAL SYSTEM

## COMPONENT LOCATION

Item	Description
A1	Controller, Speed
E1	Control Panel Assembly
F1	Fuse 150 Amp
F2	Circuit Breaker, 45 Amp (Wheel Drive)
F3	Circuit Breaker, 10 Amp (Control Circuit)
H1	Horn / Backup Alarm
H2	Headlight (Optional)
H3	Strobe Light (Optional)
K1	Contactors, Brush Motor
K2	Contactors, Vacuum Motor
L1	Solenoid Valve (Maintenance)
L2	Solenoid Valve (Restoration)
M1	Lift Actuator, Brush
M3	Motor, Drive Wheel
M4	Motor, Pump
M5	Motor, Vacuum
M6	Motor, Vacuum
M7	Motor, Brush
M8	Motor, Brush
R1	Potentiometer, 5K
S1	Switch, Key

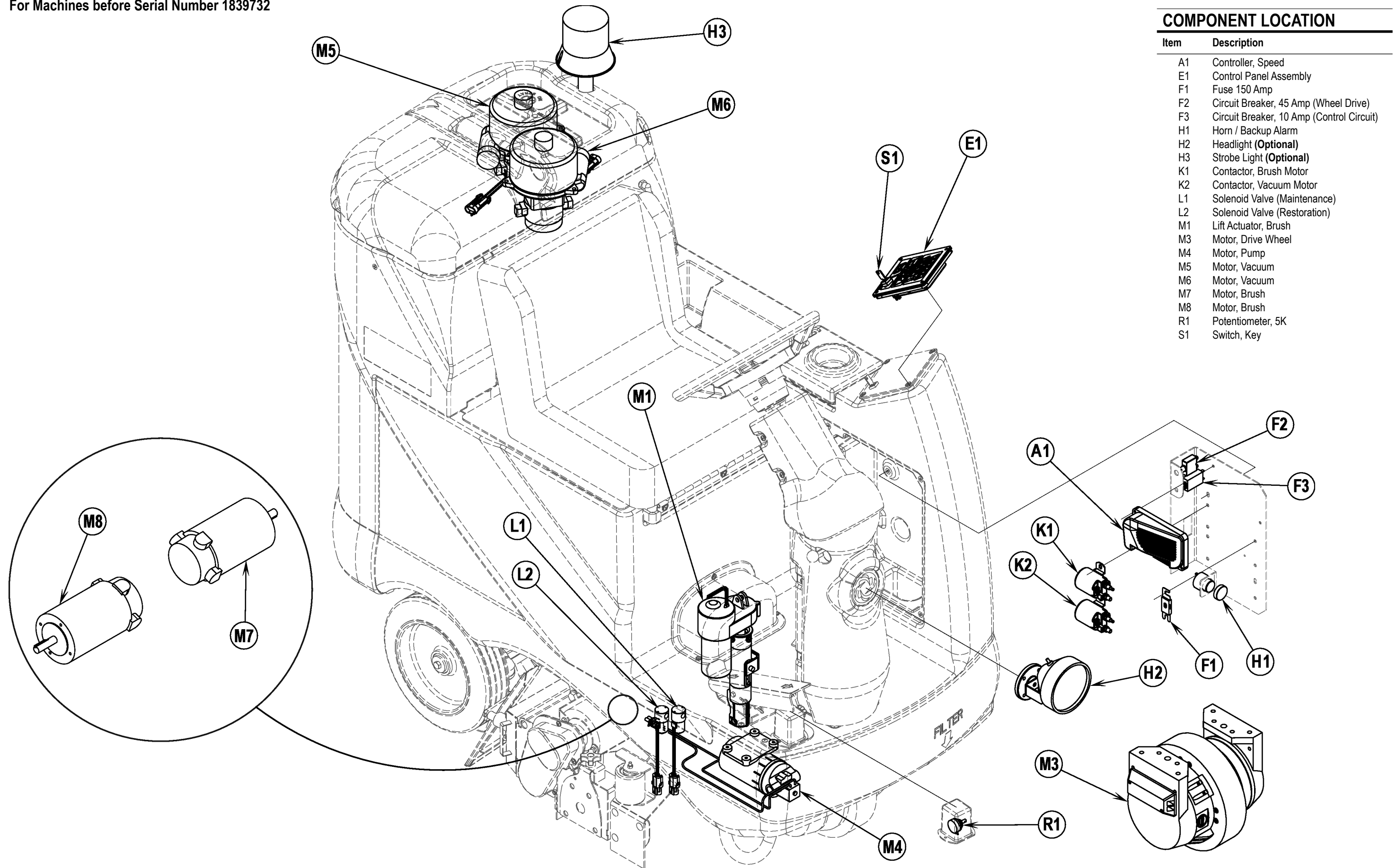

# ELECTRICAL SYSTEM

## WIRING DIAGRAM / SCHEMATIC FOR BRX 700 before Serial Number 1839732

Item	Description
------	-------------

A1	CONTROLLER
BT1	BATTERY
E1	CONTROL PANEL ASSEMBLY
F1	FUSE, 150 AMP
F2	CIRCUIT BREAKER, 45 AMP (WHEEL DRIVE)
F3	CIRCUIT BREAKER, 10 AMP (CONTROL CIRCUIT)
F4	FUSE, 1 AMP
F5	CIRCUIT BREAKER, 10 AMP (SIDE BROOM / OPTIONAL)
H1	HORN / BACKUP ALARM
H2	HEADLIGHT (OPTIONAL)
H3	STROBE LIGHT (OPTIONAL)
K1	CONTACTOR, BRUSH MOTOR
K2	CONTACTOR, VAC MOTOR
L1	SOLENOID VALVE (MAINTENANCE)
L2	SOLENOID VALVE (RESTORATION)
M1	LIFT ACTUATOR, BRUSH
M3	MOTOR, DRIVE WHEEL
M4	MOTOR, PUMP
M5	MOTOR, VACUUM 36VDC
M6	MOTOR, VACUUM 36VDC
M7	MOTOR, BRUSH 36VDC
M8	MOTOR, BRUSH 36VDC
M9	MOTOR, SIDE BROOM (OPTIONAL)
R1	POTENTIOMETER, 5K
S1	SWITCH, KEY
S2	SWITCH, SEAT
S3	SWITCH, PUMP
S4	SWITCH, HEADLIGHT
S5	SWITCH, SIDE BROOM

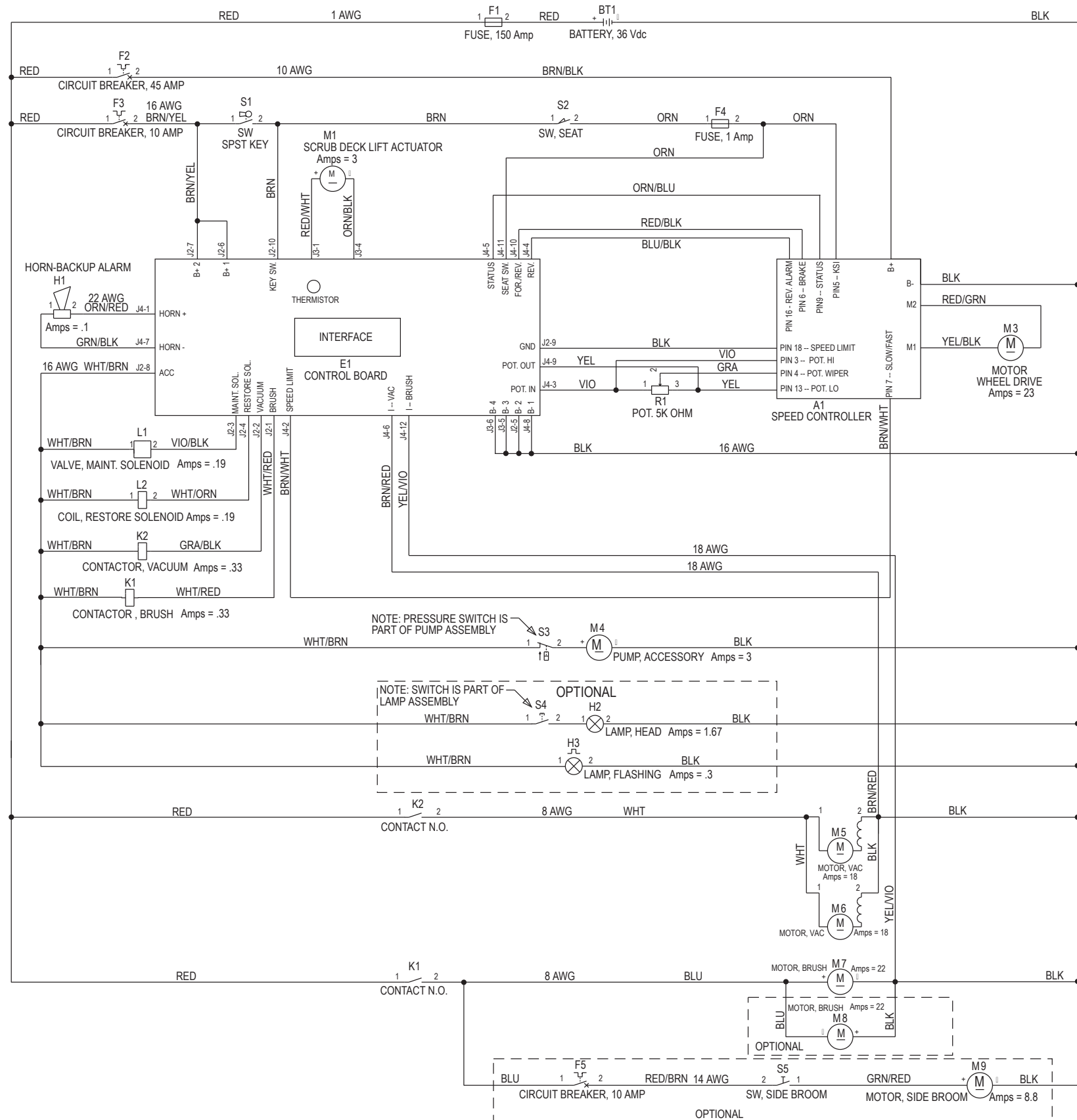

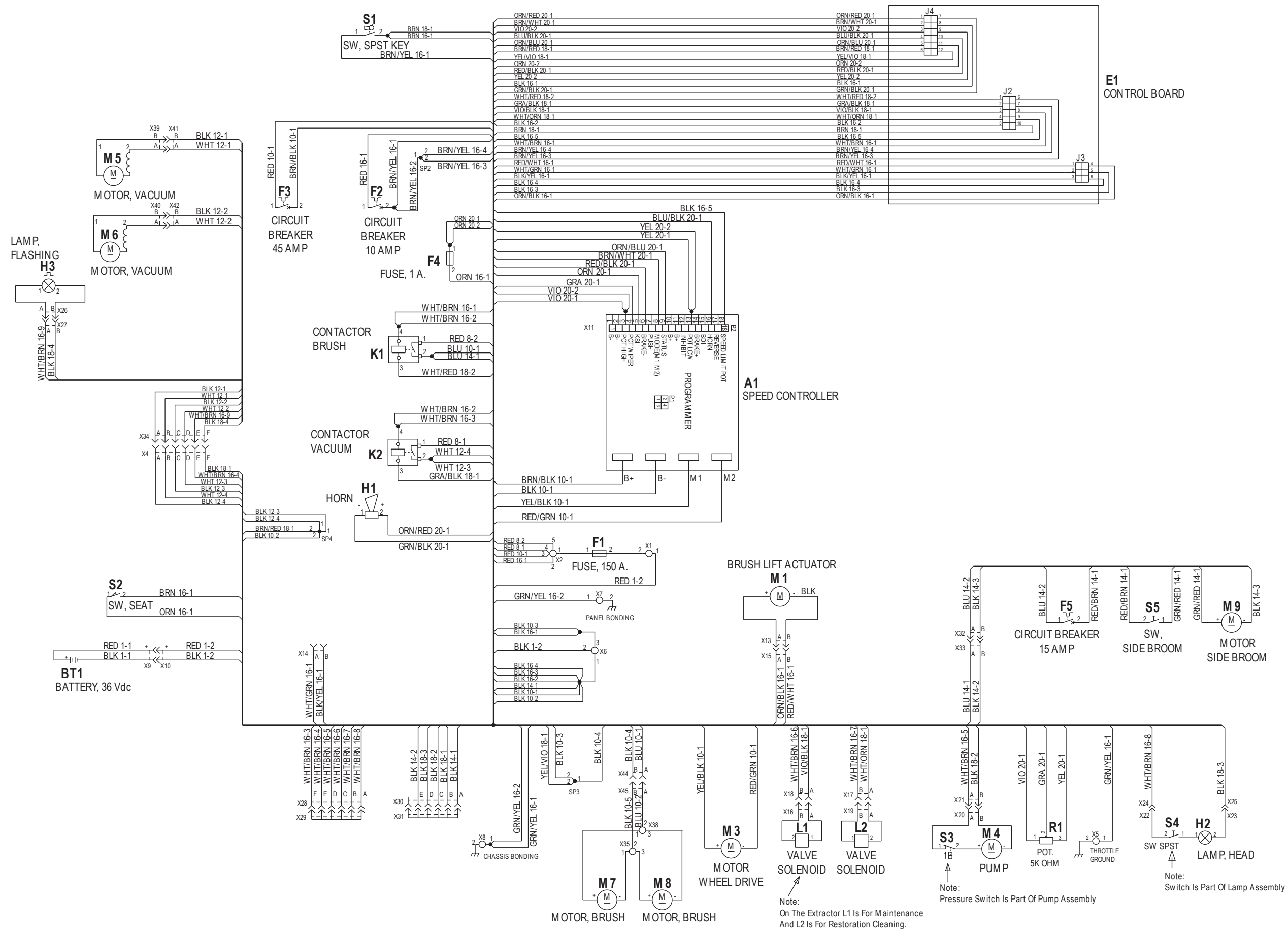

# ELECTRICAL SYSTEM

## WIRING DIAGRAM / SCHEMATIC FOR BRX 700 after Serial Number 1839732

Item	Description
A1	CONTROLLER
BT1	BATTERY
E1	CONTROL PANEL ASSEMBLY
E2	CONTROL ASSEMBLY (EDS only)
F1	FUSE, 150 AMP
F2	CIRCUIT BREAKER, 45 AMP (WHEEL DRIVE)
F3	CIRCUIT BREAKER, 10 AMP (CONTROL CIRCUIT)
F4	FUSE, 1 AMP
F5	CIRCUIT BREAKER, 10 AMP (SIDE BROOM / OPTIONAL)
H1	HORN / BACKUP ALARM
H2	HEADLIGHT (OPTIONAL)
H3	STROBE LIGHT (OPTIONAL)
K1	CONTACTOR, BRUSH MOTOR
K2	CONTACTOR, VAC MOTOR
L1	SOLENOID VALVE, (MAINTENANCE)
L2	SOLENOID VALVE, (RESTORATION)
M1	LIFT ACTUATOR, BRUSH
M3	MOTOR, DRIVE WHEEL
M4	MOTOR, PUMP (OPTIONAL)
M5	MOTOR, VACUUM 36VDC
M6	MOTOR, VACUUM 36VDC
M7	MOTOR, BRUSH 36VDC
M8	MOTOR, BRUSH 36VDC
M9	MOTOR, SIDE BROOM (OPTIONAL)
M11	MOTOR, PUMP (OPTIONAL)
M12	PUMP, CHEMICAL (EDS only)
M13	MOTOR, FAN
R1	POTENTIOMETER, 5K
S1	SWITCH, KEY
S2	SWITCH, SEAT
S3	SWITCH, PUMP (part of M4)
S4	SWITCH, HEADLIGHT (part of H2)
S5	SWITCH, SIDE BROOM (OPTIONAL)
S6	SWITCH, PUMP (part of M11)

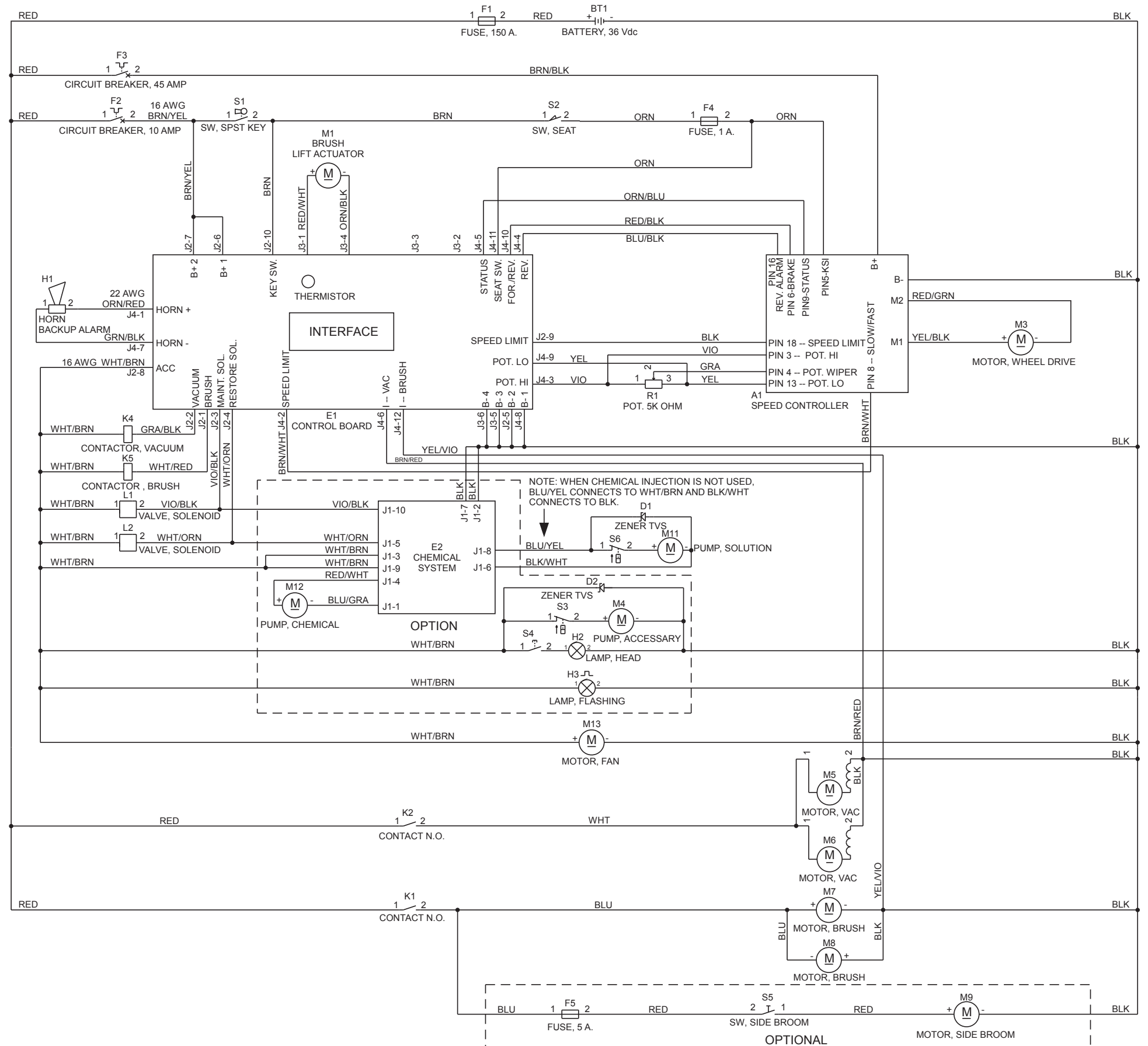

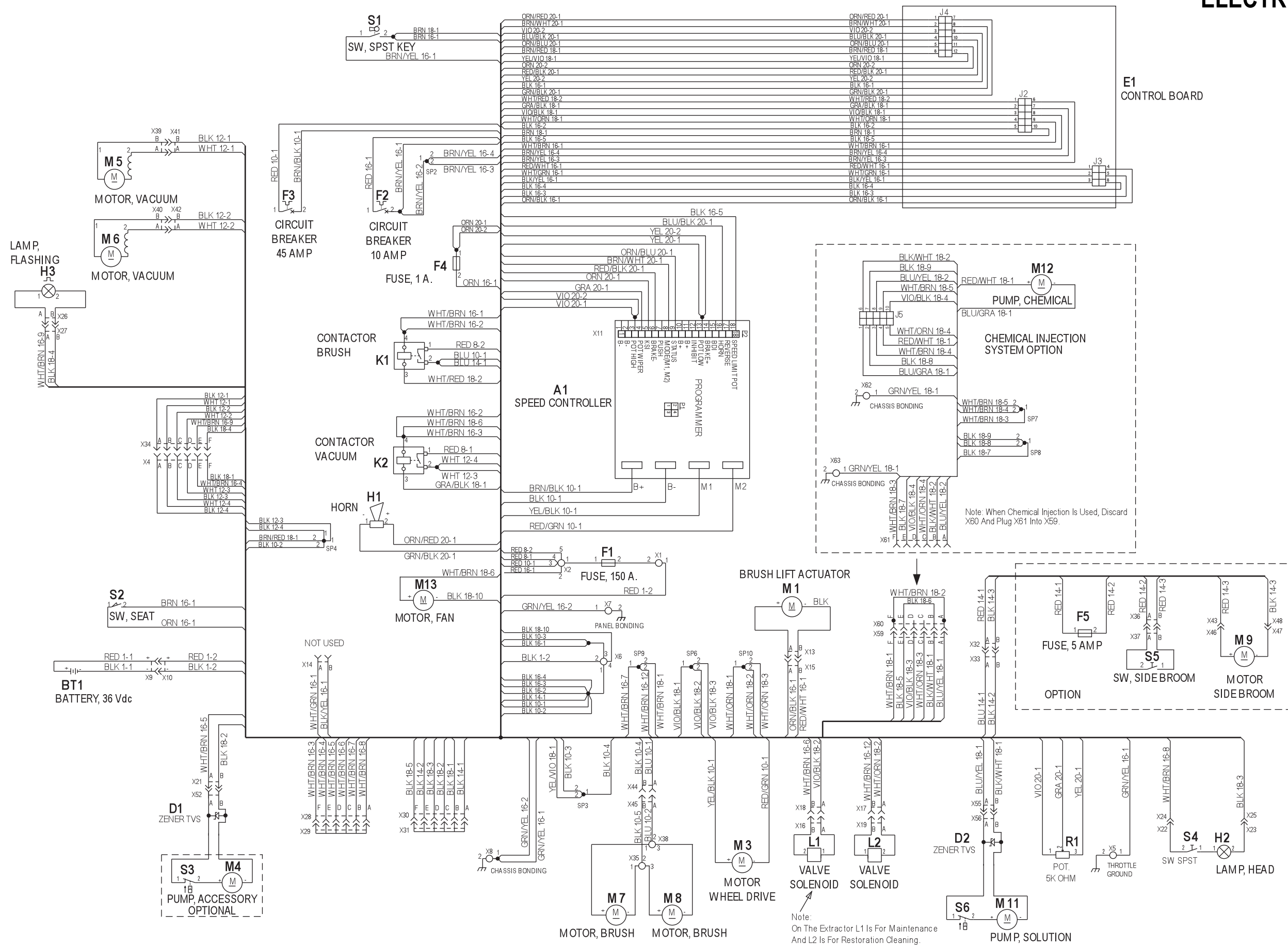

For Machines after Serial Number 1839732

# ELECTRICAL SYSTEM

## COMPONENT LOCATION

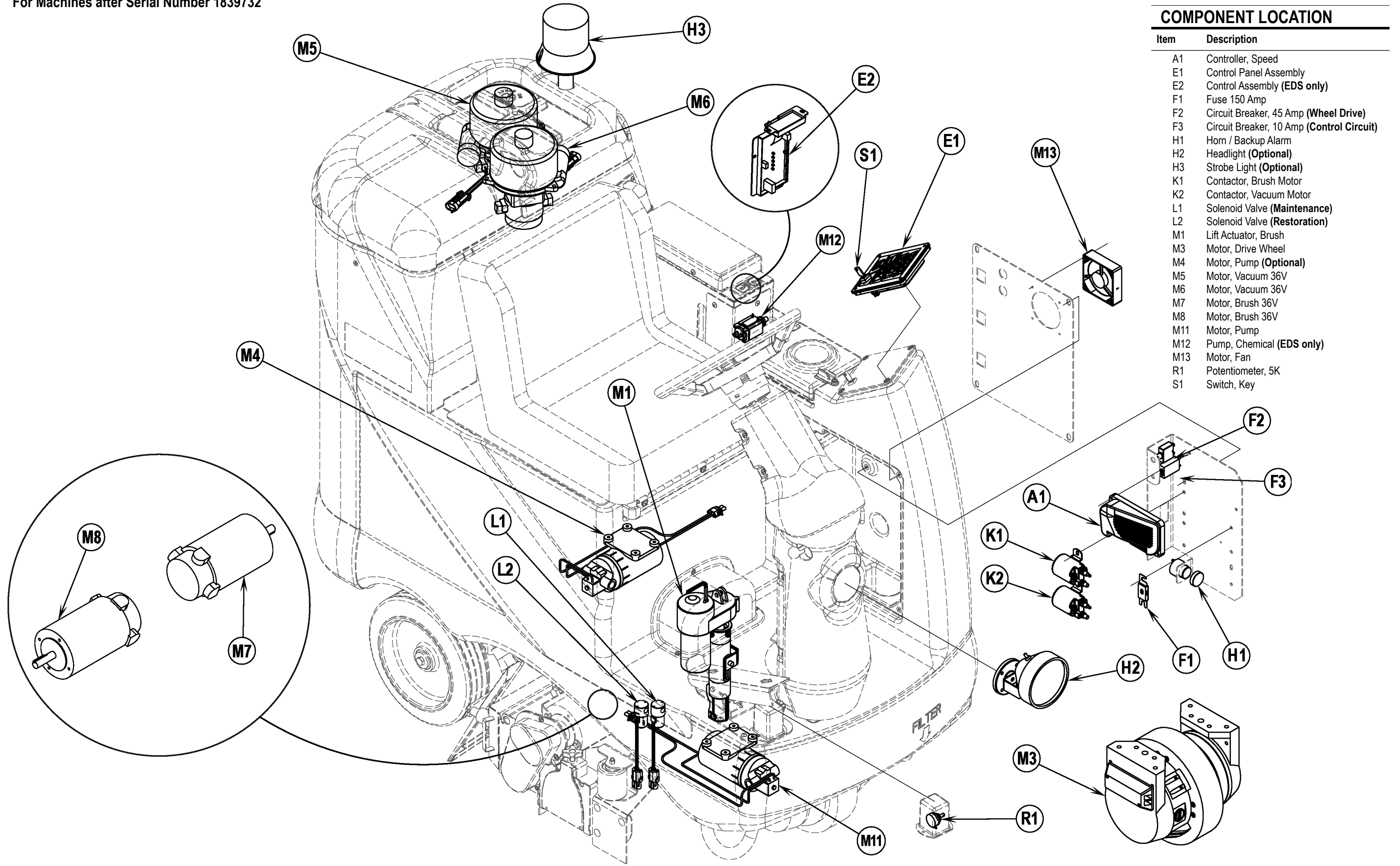

Item	Description
A1	Controller, Speed
E1	Control Panel Assembly
E2	Control Assembly (EDS only)
F1	Fuse 150 Amp
F2	Circuit Breaker, 45 Amp (Wheel Drive)
F3	Circuit Breaker, 10 Amp (Control Circuit)
H1	Horn / Backup Alarm
H2	Headlight (Optional)
H3	Strobe Light (Optional)
K1	Contactor, Brush Motor
K2	Contactor, Vacuum Motor
L1	Solenoid Valve (Maintenance)
L2	Solenoid Valve (Restoration)
M1	Lift Actuator, Brush
M3	Motor, Drive Wheel
M4	Motor, Pump (Optional)
M5	Motor, Vacuum 36V
M6	Motor, Vacuum 36V
M7	Motor, Brush 36V
M8	Motor, Brush 36V
M11	Motor, Pump
M12	Pump, Chemical (EDS only)
M13	Motor, Fan
R1	Potentiometer, 5K
S1	Switch, Key



**Nilfisk**  
*setting standards*

Nilfisk-Advance A/S  
Sognevej 25  
DK-2605 Brøndby  
Denmark  
Tel: +45 43 23 81 00  
Fax: +45 43 43 77 00  
[www.nilfisk-advance.com](http://www.nilfisk-advance.com)