



Electronic Service Manuals

This electronic document is provided as a service to our customers. We do not create the contents of the information contained in this document. Should you have detailed questions pertaining to the information contained in this document, you may contact Michco, or the manufacturer which provided the original information in this electronic deliverable. Michco's only part in this electronic deliverable was the electronic assembly process.

You may contact Michco through the following methods:
Phone (517) 484-9312 or (800) 331-3339 MI, OH, IN only
2011 N. High St. -- Lansing, Michigan -- 48906
Fax: (517) 484-9836
Email: CustServ@Michco.com
Web site: www.Michco.Com
Parts Web site: www.FloorMachineParts.Com

Order Parts on Line at:
www.FloorMachineParts.Com

Directly to Parts & Service:
By Email: **Shop@Michco.com**
By Fax: (517) 702-2041
By Voice: Use numbers above.

Serving the Cleaning Industry Since 1922

Notice: All copyrighted material remains property of original owners, all trademarks are property of respective owners. Manuals are subject to Manufacturer's reproduction limitations. Originals or reproductions were provided by manufacturers through a request. We make no warranty as to the correctness of information provided in this document and you assume all risk.

OPERATOR

M A N U A L
A N D P A R T S L I S T

Shadow™ 17, 20

Models 56201101, 56201102, 56201355
56201250, 56201586



TECHNICAL SPECIFICATIONS

Model	Shadow™ 17	Shadow™ 20
Model Number	201101	201102
Motor	1.25 hp, 120V	1.25 hp, 120V
Transmission	Dual-Planetary	Dual-Planetary
Pad/Brush Speed	175 rpm	175 rpm
Pad/Brush Size	17" (43 cm)	20" (51 cm)
Wheels	5" (15 cm)	5" (15 cm)
Cord Length	50' (15 m)	50' (15 m)
Base Width	18" (46 cm)	20.75" (53 cm)
Height w/Handle	47" (120 cm)	47" (120 cm)
Net Weight (w/pad holder)	86 lbs (39 kg)	90 lbs (41 kg)
Shipping Weight (w/pad holder)	90 lbs (41 kg)	94 lbs (43 kg)
Construction:		
Handle Tube	Extruded Aluminum	Extruded Aluminum
Upper Handle	Injection Molding Polypropylene	Injection Molding Polypropylene
Base	Roto Molding Polyethylene	Roto Molding Polyethylene

TABLE OF CONTENTS

	PAGE
INTRODUCTION	2
IMPORTANT SAFETY INSTRUCTIONS	3
IMPORTANTES MESURES DE SÉCURITÉ	4
GROUNDING INSTRUCTIONS	5
MACHINE ASSEMBLY	6
PREPARING THE MACHINE FOR USE	7
OPERATING CONTROLS	8
OPERATION.....	9
AFTER USE	10
TROUBLESHOOTING	11
HANDLE SYSTEM	12-13
BASE SYSTEM	14-15
WIRING DIAGRAM	15
SOLUTION TANK KIT (OPTIONAL).....	16-17

INTRODUCTION

This manual will help you get the most from your **Advance Shadow™ Floor Machine**. Read it thoroughly before operating the machine.

This product is intended for commercial use; polishing, spray buffing, scrubbing, stripping and rotary carpet shampooing.

PARTS AND SERVICE

Call the DEALER named below for repair parts or service. Please specify the Model and Serial number when discussing your machine.

(Dealer, affix service sticker here)

NAME PLATE

The Model Number and Serial Number of your machine are shown on the Nameplate on the back of the motor. This information is often needed when ordering repair parts for the machine. Use the space below to note the Model Number and Serial Number of your machine for future reference.

MODEL NUMBER _____

SERIAL NUMBER _____

UNCRATING

When the machine is delivered, carefully inspect the shipping carton and the machine for damage. If damage is evident, save the shipping carton so that it can be inspected. Contact the Advance Customer Service Department immediately to file a freight damage claim.

IMPORTANT SAFETY INSTRUCTIONS

When using an electrical appliance, basic precautions should always be followed, including the following:

Read all instructions before using.

WARNING!

To reduce risk of fire, electric shock, or injury:

- * Do not leave the appliance when it is plugged in. Unplug the unit from the outlet when not in use and before servicing.
- * To avoid electric shock, do not expose to rain. Store indoors.
- * Do not allow to be used as a toy. Close attention is necessary when used by or near children.
- * Use only as described in this manual. Use only manufacturer's recommended attachments.
- * Do not use with damaged cord or plug. If appliance is not working as it should, has been dropped, damaged, left outdoors, or dropped into water, return it to a service center.
- * Do not pull or carry by cord, use cord as a handle, close a door on a cord, or pull cord around sharp edges or corners. Do not run appliance over cord. Keep cord away from heated surfaces.
- * Do not unplug by pulling on cord. To unplug, grasp the plug, not the cord.
- * Do not handle plug or appliance with wet hands.
- * Do not put any object into openings. Do not use with any opening blocked; keep free of dust, lint, hair, and anything that may reduce air flow.
- * Keep hair, loose clothing, fingers, and all parts of body away from openings and moving parts.
- * Turn off all controls before unplugging.
- * Use extra care when cleaning on stairs.
- * Do not use to pick up flammable or combustible liquids such as gasoline or use in areas where they may be present.
- * Connect to a properly grounded outlet only. See Grounding Instructions.

SAVE THESE INSTRUCTIONS

IMPORTANTES MESURES DE SÉCURITÉ

L'utilisation d'un appareil électrique demande certaines précautions:

LIRE TOUTES LES INSTRUCTIONS AVANT DE FAIRE FONCTIONNER (CET APPAREIL)

AVERTISSEMENT:

Pour réduire les risques d'incendie, de choc électrique ou de blessure:

- * Ne pas laisser l'appareil sans surveillance lorsqu'il est branché. Débrancher lorsque l'appareil n'est pas utilisé et avant l'entretien.
- * Pour réduire les risques de choc électrique, utiliser à l'intérieur seulement.
- * Ne pas permettre aux enfants de jouer avec l'appareil. Une attention particulière est nécessaire lorsque l'appareil est utilisé par des enfants ou à proximité de ces derniers.
- * N'utiliser que conformément à cette notice avec les accessoires recommandés par le fabricant.
- * Ne pas utiliser si le cordon ou la fiche est endommagé. Retourner l'appareil à un atelier de réparation s'il ne fonctionne pas bien, s'il est tombé ou s'il a été endommagé, oublié à l'extérieur ou immergé.
- * Ne pas tirer soulever ou traîner l'appareil par le cordon. Ne pas utiliser le cordon comme une poignée, le coincer dans l'embrasure d'une porte ou l'appuyer contre des arêtes vives ou des coins. Ne pas faire rouler l'appareil sur le cordon. Garder le cordon à l'écart des surfaces chaudes.
- * Ne pas débrancher en tirant sur le cordon. Tirer plutôt la fiche.
- * Ne pas toucher la fiche ou l'appareil lorsque vos mains sont humides.
- * N'insérer aucun objet dans les ouvertures. Ne pas utiliser l'appareil lorsqu'une ouverture est bloquée. S'assurer que de la poussière, de la peluche, des cheveux ou d'autres matières ne réduisent pas le débit d'air.
- * Maintenir les cheveux, les vêtements amples, les doigts et toutes les parties du corps à l'écart des ouvertures et des pièces mobiles.
- * Mettre toutes les commandes à la position ARRÊT avant de débrancher l'appareil.
- * User de prudence lors du nettoyage des escaliers.
- * Ne pas aspirer des liquides inflammables or combustibles, comme de l'essence, et ne pas faire fonctionner dans des endroits ou peuvent se trouver de tels liquides.
- * Ne brancher qu'à une prise de courant avec mise à la terre. Voir les instructions visant la mise à la terre.

CONSERVER CES INSTRUCTIONS

GROUNDING INSTRUCTIONS

This appliance must be grounded. If it should electrically malfunction, grounding provides a path of least resistance for electric current to reduce the risk of electric shock. This appliance is equipped with a cord having an equipment-grounding conductor and grounding plug. The plug must be plugged into an appropriate outlet that is properly installed and grounded in accordance with all local codes and ordinances.

⚠ DANGER!

Improper connection of the equipment-grounding conductor can result in a risk of electric shock. Check with a qualified electrician or service person if you are in doubt as to whether the outlet is properly grounded. Do not modify the plug provided with the appliance. If it will not fit the outlet, have a proper outlet installed by a qualified electrician.

This appliance is for use on a nominal 120-volt circuit, and has a grounding plug that looks like the plug illustrated in Figure 1 below. A temporary adapter illustrated in Figures 2 and 3 may be used to connect this plug to a 2-pole receptacle as shown in Figure 2 if a properly grounded outlet is not available. The temporary adapter should be used only until a properly grounded outlet (Figure 1) can be installed by a qualified electrician. The green-colored rigid ear, tab, or the like extending from the adapter must be connected to a permanent ground such as a properly grounded outlet box cover. Whenever the adapter is used, it must be held in place by a metal screw. Grounding adapters are not approved for use in Canada.

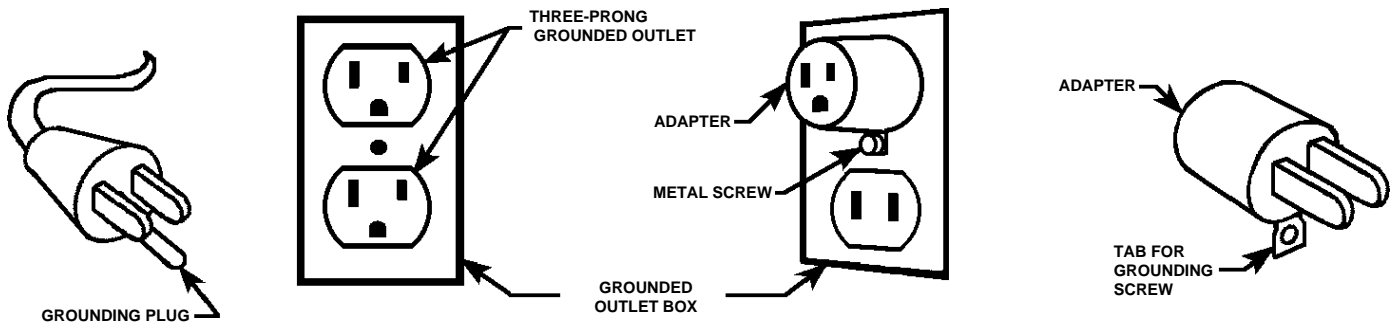

FIGURE 1

FIGURE 2

FIGURE 3

Replace the plug if the grounding pin is damaged or broken.

The Green (or Green/Yellow) wire in the cord is the grounding wire. When replacing a plug, this wire must be attached to the grounding pin only.

Extension cords connected to this machine should be 12 gauge, three-wire cords with three-prong plugs and outlets. DO NOT use extension cords more than 50 feet (15 m) long.

MACHINE ASSEMBLY

Handle to base, tools needed; (2) 9/16" open end or combination wrenches.

- 1 Unpack the supplied hardware and become familiar with the part assembly by studying Figure 1.
- 2 Install the (2) "K" bushings into the base housing support ears as shown.
- 3 Position the Handle Tube "J" between the "K" Bushings, making sure the power cord is on the left side of the machine as shown. Insert the Spacer "N" into the opening in the bottom of the Handle Tube "J" and align the spacer with the holes in the Handle Tube.
- 4 Attach the handle tube to the base housing using the long bolt "L" and nut "M" (hold Spacer "N" in place so Bolt "L" goes through it).
- 5 Install the handle arm latch "H" to the handle tube "J" using the supplied hardware items "A" - "G" as shown.
- 6 Plug the (2) power cord ends together as shown.

Items "A" - "G" function together as the handle position lock lever "Quick-Loc". The "Quick-Loc" lever is locked by pushing the lever down and released by pulling up. NOTE: To eliminate any slippage, tighten nut "G".

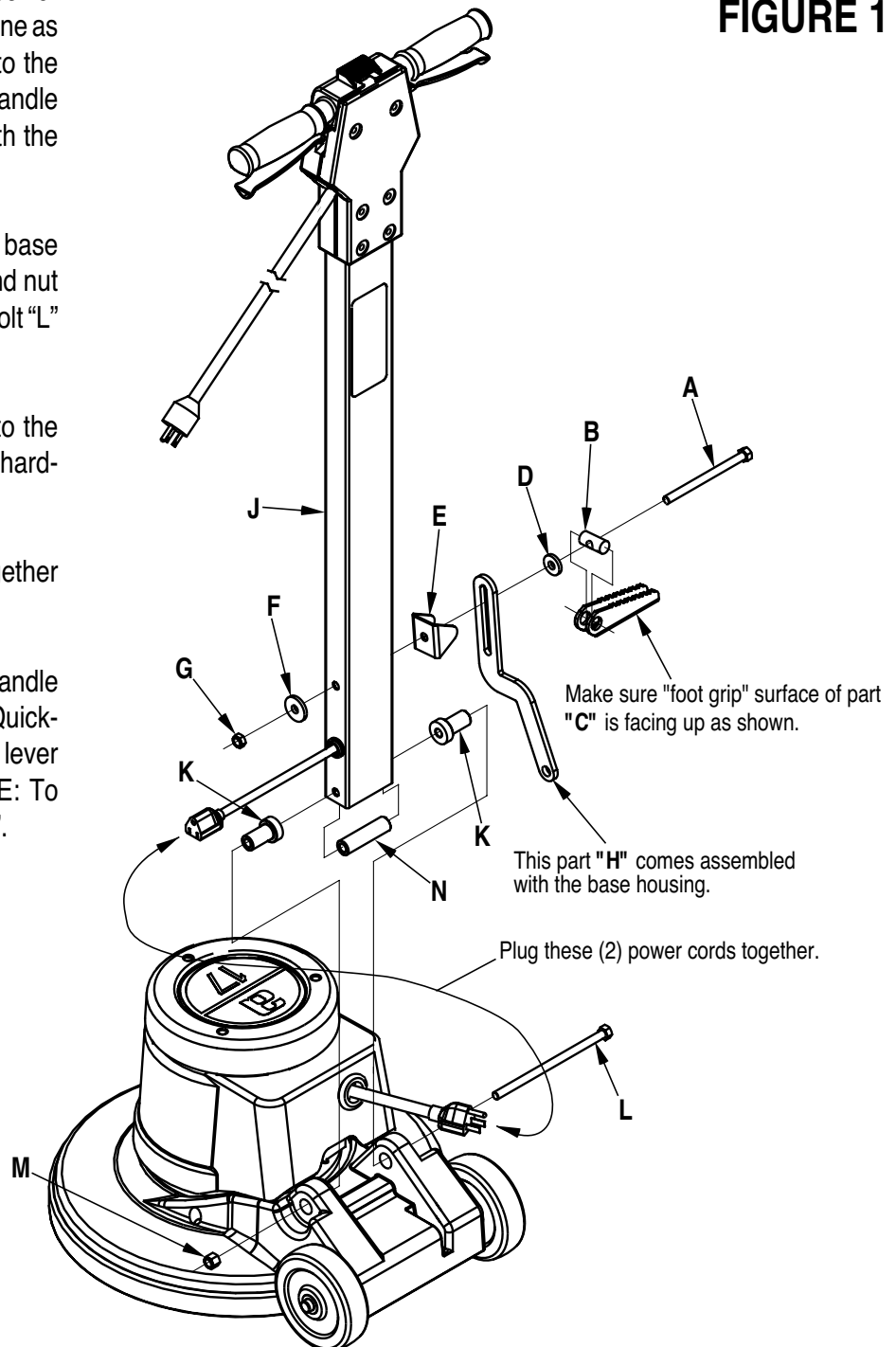

FIGURE 1

PREPARING THE MACHINE FOR USE

⚠ WARNING!

This machine contains moving parts. To reduce the risk of injury, always unplug the power cord before servicing.

INSTALLING THE BRUSH OR PAD HOLDER

Align the lugs with the corresponding slots in the brush or pad holder and turn the brush or pad holder counterclockwise to lock it in place. To remove brush/pad holder, give it a quick, hard turn clockwise.

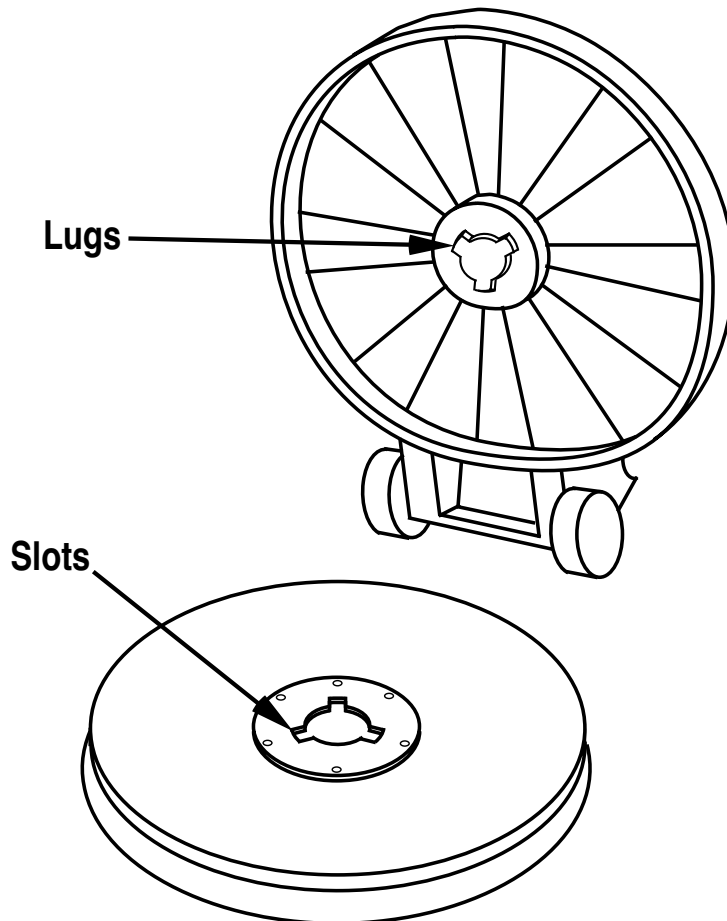

⚠ CAUTION!

Using the wrong brush or pad on this machine can damage the floor or overload the motor.

OPERATING CONTROLS

- 1 Operator Handle Grips
- 2 Switch Lever Safety Lock Button
- 3 Switch Levers - Squeeze - ON / Release - OFF
- 4 "Quick-Loc" Handle Adjustment Lever
- 5 Power Cord
- 6 Operator Handle

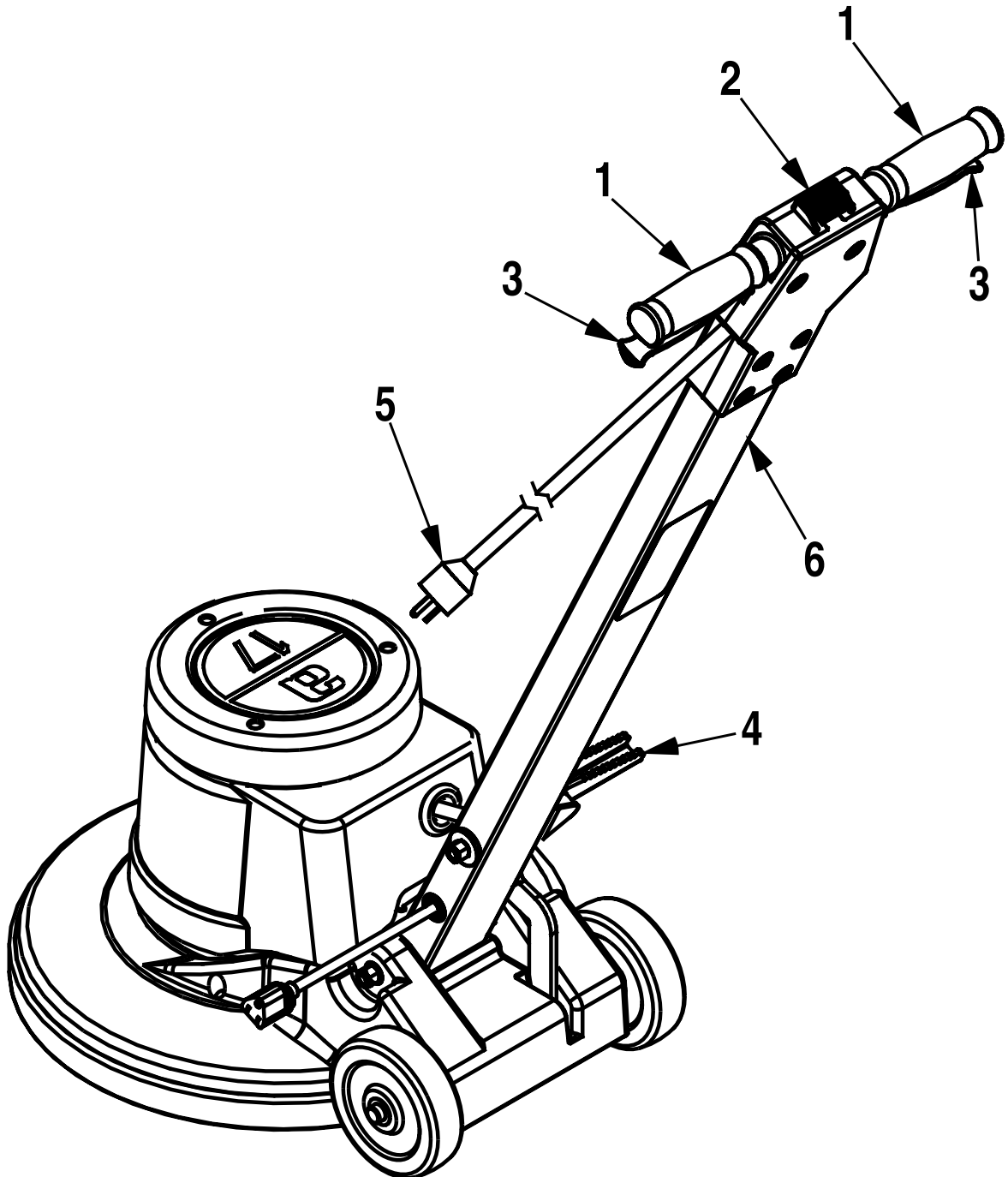

- 1 Unwrap the Power Cord and plug it into a properly grounded outlet.
- 2 Loosen the foot operated “Quick-Loc” lever with the toe of your foot by pulling up on the bottom of the lever. Move the Operator Handle downward until your arms are almost straight. Then step down on top of the lever to lock it.
- 3 Lift the Handle until the brush (or pad) is flat against the floor.

WARNING!

Be prepared to control the machine as soon as the motor starts.

Just a slight up or down movement of the Handle will make the machine move from side to side. Raise the Handle to go right. Lower the Handle to go left.

CAUTION!

Immediately start moving the machine back and forth. Keep the machine moving while the motor is running to avoid damage to the floor or carpet.

- 4 Hold one of the Operator Hand Grips firmly, push the Safety Lock Button and then compress the switch levers to start the motor. **NOTE:** When the dual controlled switch levers are released, the machine shuts off immediately.

NOTE: When spray buffing, check the pad every 15 minutes for dirt and wax build-up. If the pad is dirty, turn it over to expose the clean side or install a clean pad.

AFTER USE

- 1 Unplug the Power Cord, coil it and hang it from the Operator Handle Grips.
- 2 Remove the pad holder or brush from the machine. Clean the pad or brush and hang it up to dry. Allow buffing pads to dry completely before using again.
Store brushes and pad holders separate from the machine. Never store the machine with the pad holder or brush on the machine.
- 3 Wipe the entire machine with a clean, damp cloth. Wipe the underside of the brush housing after wet use.
- 4 Inspect the entire machine and all accessories for damage. Perform any required maintenance or repairs before storage.
- 5 Store the machine in a clean, dry place with the Handle locked in the upright position.

SWIRLS ON THE FLOOR AFTER SCRUBBING

- Floor not clean.
- Incorrect solution.
- Area not properly swept - debris in pad or brush.
- Improper pad or brush for the job.
- Moving the machine too fast.

SWIRLS ON THE FLOOR AFTER DRY BUFFING

- Moving the machine too fast.
- Floor finish too soft.
- Area not properly swept - debris in pad or brush.
- Improper pad or brush for the job.

CIRCLES ON THE FLOOR

- Machine standing still while the brush or pad is running.

FLOOR FINISH REMOVED

- Improper pad... too aggressive.
- Solution too strong.

MACHINE WOBBLER DURING OPERATION

- Defective pad... one side is more dense than the other.
- Machine left sitting on brush or pad for extended period of time causing bristles or pad to "take a set".
- Pad not "seated" properly into pad holder bristles.
- Warped block on brush or padholder - replace.

MACHINE DOES NOT RUN

- Check plug for proper connection - on machine and at wall outlet.
- Check building circuit breaker.
- Call for service.

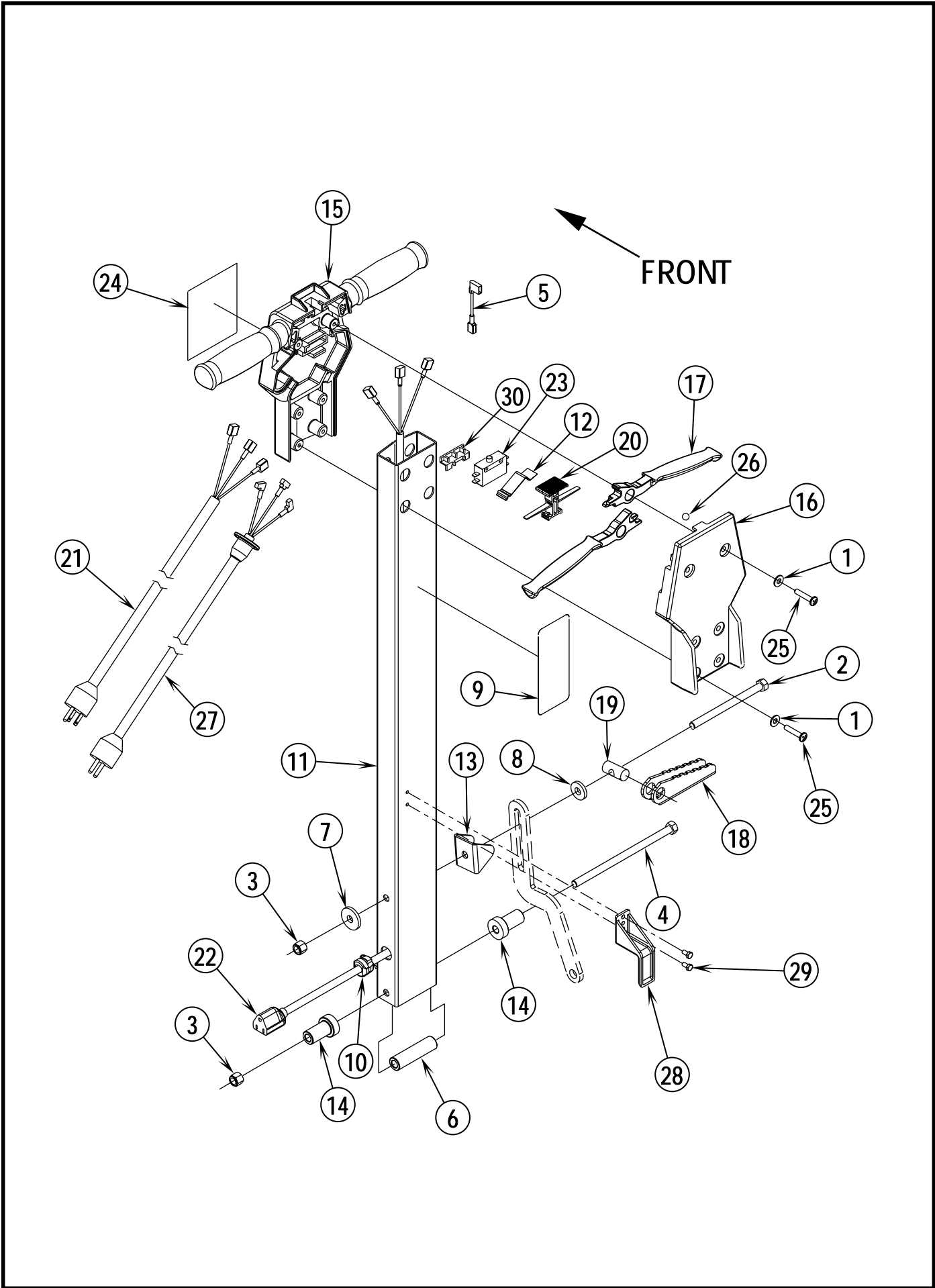

HANDLE SYSTEM

Item	Ref. No.	Qty	Description
1	56002098	6	Wsh, Flt SAE 1/4
2	56002506	1	Scr, Hex Hd 3/8-16 x 5.00
3	56002769	2	Nut, Hex Nyl Loc 3/8-16
4	56002777	1	Scr, Hex Hd 3/8-16 x 7.00
5	56201068	1	Wire Assembly (230V)
6	56201023	1	Spacer
7	56009195	1	Wsh, Flt .40 x 1.25 x .16
8	56009196	1	Wsh, Flt Hardened .40 x 1.00 x .16
9	56014828	1	Decal, Warning
10	56382818	1	Strain Relief
11	56201056	1	Handle Tube
12	56263648	1	Spring, Plate
13	56201015	1	Bracket
14	56201016	2	Bushing
15	56201054	1	Handle (120V)
	56201560	1	Handle (230V)
16	56201026	1	Handle Cover (120V)
	56201058	1	Handle Cover (230V)
17	56201027	2	Handle Lever
18	56201028	1	Latch Arm
19	56201029	1	Pin
20	56201031	1	Button, Lock
21	56201032	1	Cord Set 14/3 x 50' (120V)
22	56201033	1	Cord Assembly 14/3
23	56201034	1	Switch, N.O. SPST Snap (120V)
	56201648	1	Switch, N.O. DPDT (230V) TSBUS2003-857
24	56016429	1	Decal, Logo
25	56002292	6	Scr, Pan Phil 1/4-20 x 1.00
26	56201592	1	Ball, 1/4 SS
27	56201354	1	Powercord (230V)
28	56392765	1	Hook, Cord
29	56009012	2	Scr, Hex Thd Form 10-24 x .38
30	56201647	1	Spacer, Plastic (230V) TSBUS2003-857

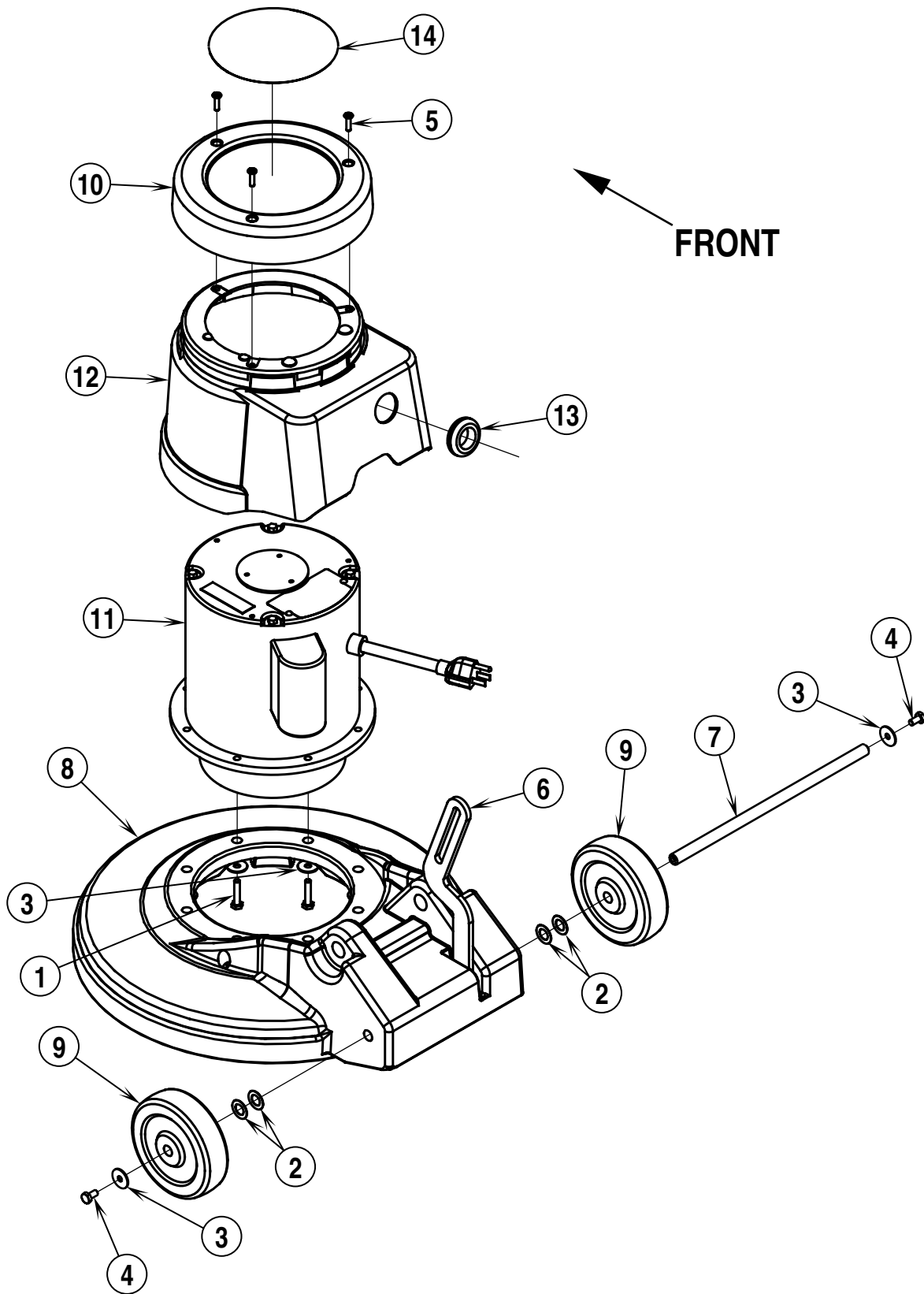

BASE SYSTEM

Item	Ref. No.	Qty	Description	Item	Ref. No.	Qty	Description
1	56003318	8	Scr, Hex Hd Loc 1/4-20 x 1.25	56505910		1	Pad Holder Assy 17 (standard)
2	56009001	4	Wsh, Bowed .51 x .90 x .008	56505920		1	Pad Holder Assy 20 (standard)
3	56009002	10	Wsh, Fit .26 x .90 x .06	** 56505270		1	Level-Set Pad Holder 17
4	56003039	2	Scr, Hex Loc 1/4-20 x .50	** 56505280		1	Level-Set Pad Holder 20
5	56009209	3	Scr, Pan Phil 10-24 x 1.00	** 56505915		1	ProLite™ Brush 17
6	56201011	1	Arm, Handle Latch	** 56505925		1	ProLite™ Brush 20
7	56201089	1	Axle	** 56505914		1	Prolene Brush 17
8	56201017	1	Base Housing 17"	** 56505924		1	Prolene Brush 20
*	56201012	1	Base Housing 20"	** 56505911		1	MagnaGrit™ 46 Brush 17
9	56201018	2	Wheel 5.00 x 1.50	** 56505921		1	MagnaGrit™ 46 Brush 20
10	56201019	1	Cover, Motor	** 56505912		1	DynaGrit™ 80 Brush 17
11	56201040	1	Motor/Gearbox 1.25HP, 10:1 (120V)	** 56505922		1	DynaGrit™ 80 Brush 20
*	56201037	1	Bearing, Front	** 56505918		1	MidLite Grit™ 180 Brush 17
*	56201038	1	Switch, Stationary	** 56505928		1	MidLite Grit™ 180 Brush 20
*	56201039	1	Switch, Rotor	** 56505917		1	MidGrit™ 240 Brush 17
*	56201042	1	Capacitor, Start	** 56505927		1	MidGrit™ 240 Brush 20
*	56201043	1	Gear Head Assembly	** 56505913		1	AgLite™ 500 Brush 17
*	56201044	1	Pinion, 13 Teeth	** 56505923		1	AgLite™ 500 Brush 20
*	56201045	1	Coupling	** 56505916		1	Union Mix Brush 17
	56201051	1	Motor/Gearbox 1.5HP, 6.25:1 (230V)	** 56505926		1	Union Mix Brush 20
12	56201055	1	Shroud, Motor (120V)	** 56505539		1	Soft-Touch™ Shampoo Brush 17
13	56486116	1	Grommet (120V)	** 56505540		1	Soft-Touch™ Shampoo Brush 20
14	56016480	1	Decal, Shadow 17	** 56506006		A/R	Clutch Plate for Above Brushes
*	56016479	1	Decal, Shadow 20	** 56393567		A/R	"Big Mouth" Pad Retainer
**	56201075	1	Weight Kit, 17"				
**	56201062	1	Weight Kit, 20"				

* = Not Shown
** = Optional

NOTE: Pad Holders and Brushes come complete with Industry Standard NP-92 Clutch Plate.

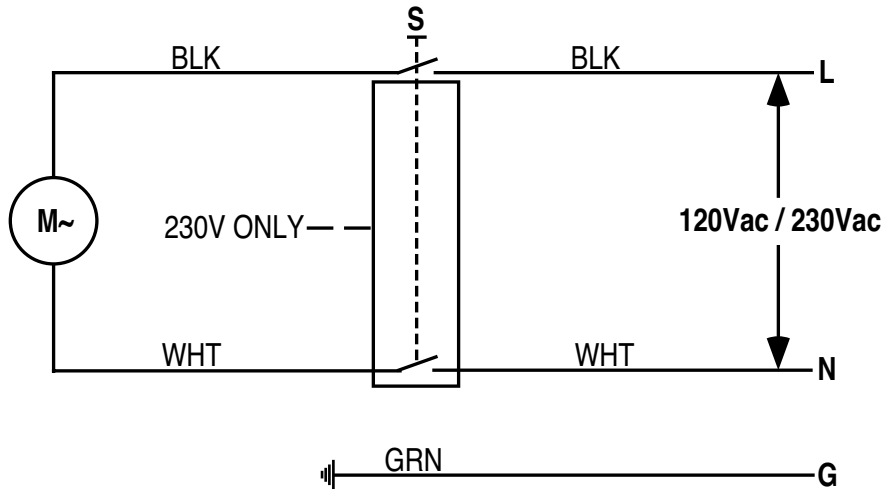

WIRING DIAGRAM

Item	Ref. No.	Qty	Description
S	56201034	1	Switch, N.O. SPST Snap (120V)
	56201053	1	Switch, N.O. DPDT (230V)
M	56201040	1	Motor/Gearbox 1.25HP, 10:1 (120V)
	56201051	1	Motor/Gearbox 1.5HP, 6.25:1 (230V)

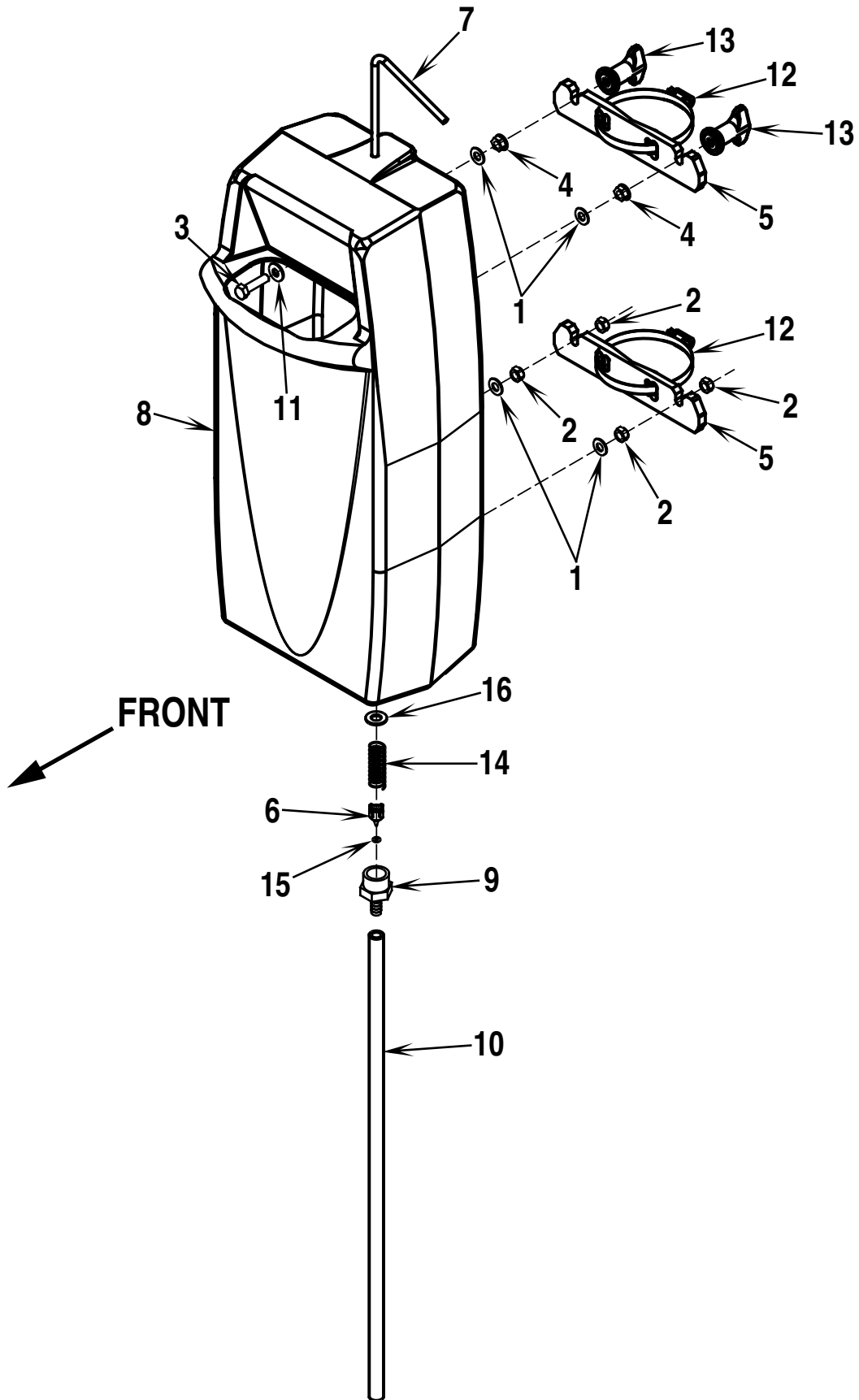

SOLUTION TANK KIT

Item	Ref. No.	Qty	Description
	56201050	1	Solution Tank Kit (includes everything below)
	56040562	1	Instruction Sheet
	56201004	1	Solution Tank Assembly (#1-15)
1	56001939	4	Wsh, Flt SAE 5/16
2	56002826	4	Nut, Hex Nyl Loc-Thin 5/16-18
3	56002884	4	Scr, Hex Hd SS 5/16-18 x 1.25
4	56009217	2	Nut, Hex Flange Loc 5/16
5	56201005	2	Strap
6	56201007	1	Plug
7	56201008	1	Handle, Valve
8	56201020	1	Tank, Solution
9	56201035	1	Barb, Adapter 3/8 x 3/4 NPT
10	56201036	1	Hose, PVC
11	56201047	4	Wsh, Sealing SS 5/16
12	56352829	2	Clamp, Hose SAE #52
13	56370711	2	Nut, Thumb
14	56379170	1	Spring, Compression
15	56745550	1	O-Ring
16	56201061	1	Washer



**Nilfisk
Advance**

setting standards

Nilfisk-Advance, Inc.

14600 21st Avenue North

Plymouth, MN 55447-3408

www.nilfisk-advance.com

Phone: 800-989-2235

Fax: 800-989-6566

©2003 Printed in the U.S.A.