



Electronic Service Manuals

This electronic document is provided as a service to our customers. We do not create the contents of the information contained in this document. Should you have detailed questions pertaining to the information contained in this document, you may contact Michco, or the manufacturer which provided the original information in this electronic deliverable. Michco's only part in this electronic deliverable was the electronic assembly process. By providing this manual on line we are not guaranteeing parts availability.

You may contact Michco through the following methods:

Phone (517) 484-9312 or (800) 331-3339

2011 N. High St. -- Lansing, Michigan -- 48906

Fax: (517) 484-9836

Email: CustServe@Michco.com

Web site: www.Michco.Com

Parts Web site: www.FloorMachineParts.Com

Order Parts on Line at:

www.FloorMachineParts.Com

Directly to Parts & Service:

By Email: **Shop@Michco.com**

By Fax: (517) 702-2041

By Voice: Use numbers above.

Serving the Cleaning Industry Since 1922

Notice: All copyrighted material remains property of original owners, all trademarks are property of respective owners. Manuals are subject to Manufacturer's reproduction limitations. Originals or reproductions were provided by manufacturers through a request. We make no warranty as to the correctness of information provided in this document and you assume all risk. By placing these manuals on line we are not declaring our corporation to be an manufacturer authorized dealer or provider, please check our web site for authorized manufacturers we represent.

SC750, SC800

SC750 ST, SC800 ST

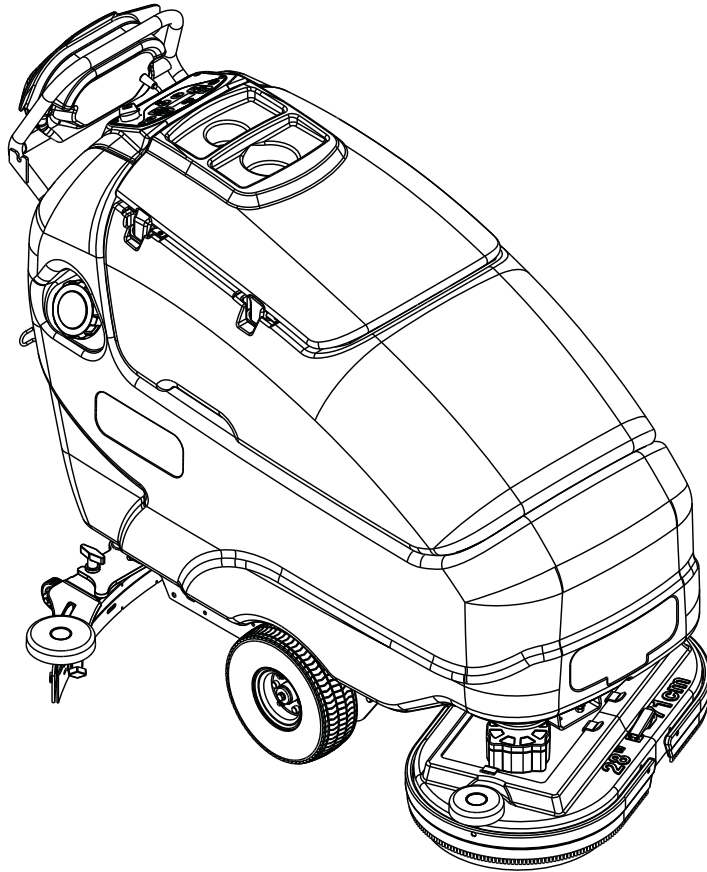

PARTS LIST

Advance Models: 56112000(SC750-26D), 56112004(SC750-28D)
56112006(SC750-28C), 56112012(SC750 ST-26D)
56112013(SC750 ST-28C), 56112016(SC800-28D)
56112018(SC800-28C), 56112024(SC800-32C)
56112028(SC800-34D), 56112032(SC800 ST-34D)
56112780(SC750-28R)



Advance

7/2010 revised 1/2015 FORM NO. 56042535 REV E

TABLE OF CONTENTS

DESCRIPTION	PAGE
Battery Charger System.....	3
Chassis System-Disk	4-5
Chassis System-Cylindrical.....	6-7
Chassis System-REV	8-9
Chemical Injection System-EcoFlex™	10
Control System-SC750, SC800.....	11
Control System-SC750 ST, SC800 ST.....	12
Decal System	13
Electrical System-SC750, SC800.....	14-15
Electrical System-SC750 ST, SC800 ST.....	16-17
Recovery System	18-19
Scrub System-Disk.....	20-21
Scrub System-Cylindrical	22-23
Scrub System-REV	24-25
Solution System	26
Squeegee Assy	27
Squeegee System.....	28-29
Ladder Diagram-SC750, SC800 before SN4000068715	30-31
Ladder Diagram-SC750, SC800 after SN4000068715	32-33
Ladder Diagram-SC750, SC800 after June 2014.....	34-35
Ladder Diagram-SC750 ST, SC800 ST before SN4000068715.....	36-37
Ladder Diagram-SC750 ST, SC800 ST after SN4000068715.....	38-39
Ladder Diagram-SC750 ST, SC800 ST after June 2014.....	40-41
Optional Kits & Accessories	42
Recommended Spare Parts.....	43
Brush Selector Guide-Disk.....	44
Brush Selector Guide-Cylindrical	45
Squeegee Blade Selector Guide.....	46

WHEN ORDERING PARTS

* Use the part numbers from the "Ref. No." columns in this parts list. If the "Ref. No." column is blank; look under the "Kit" column to identify which kit contains the part in question, then use the kit callout, for example "K1", to find the "Ref. No." for that kit.

Kit	Item	Ref. No.	Qty	Description
K1	1		16	Washer Flat 3/16 Zinc Plat
K1	2		2	Screw-BHS-Brass-10-32x3/8-MS
K1	3		3	Washer EPDM 7/32 X 1/8
	4	805	1	Chain-Cover
	5	905	2	Caster Swivel 4 Gray Non MA
K1	6		2	Nut, Hex Nyl Loc 10-24
K1	7		3	Scr- Hex SS 1/4-20 X .75
K1	8		16	Scr, Hex Hd Loc 1/4-20 x .50
K1	9		3	Wsh, Flt SS .260 X 1.000 X .074
	10	56113012	1	Solution Tank
	11	56113034	2	Hinge Plate
K1		56113103	1	Kit-Hardware Solution Tank

* Specify the model and serial number of the machine.

* Use the space below to record the model and serial number for future reference.

Model _____ Serial No. _____

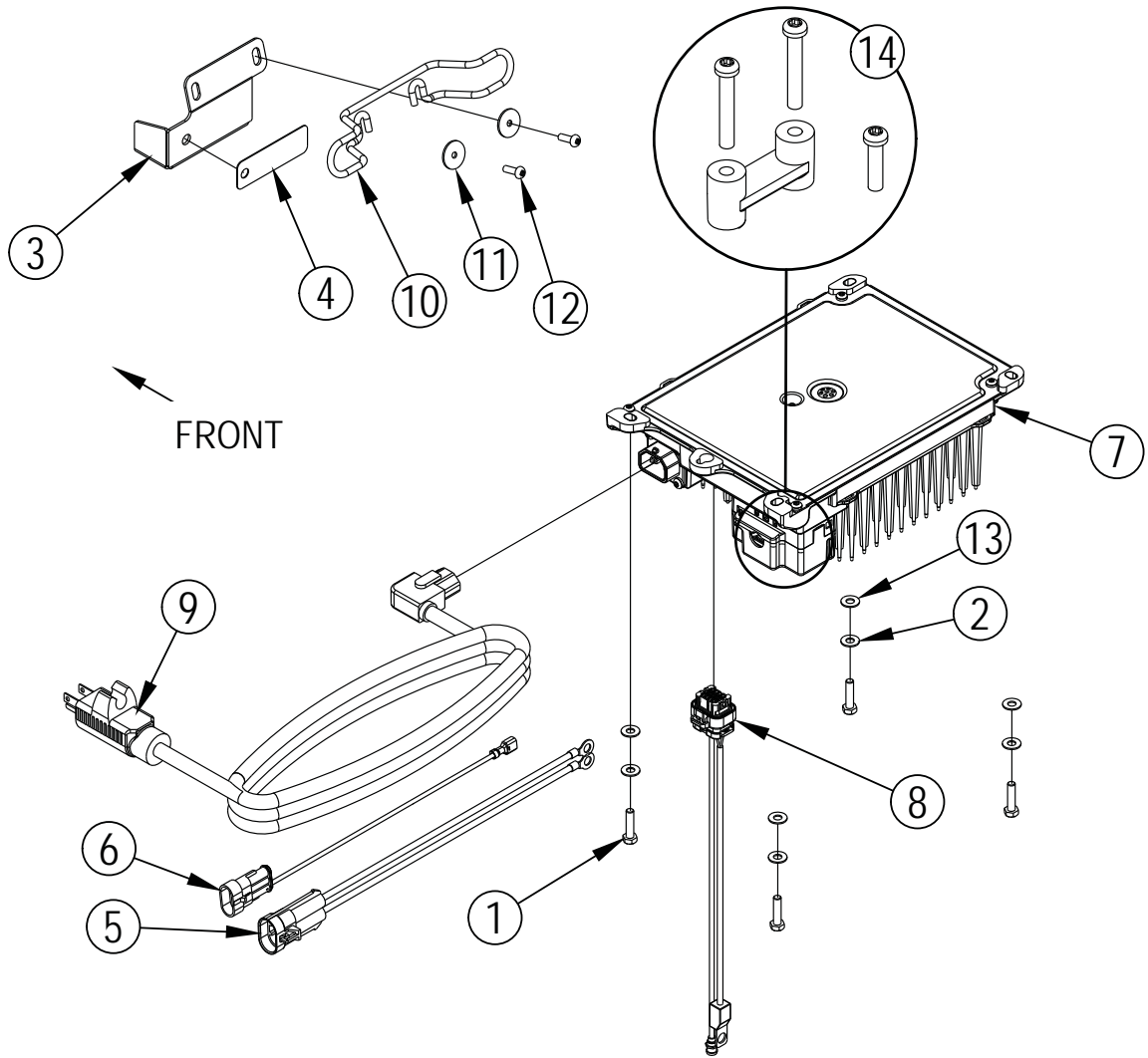

BATTERY CHARGER SYSTEM

Item	Ref. No.	Qty	Description
1	56003431	4	Scr Hex SS M6-1.00X16MM
2	56009064	4	Wsh Int Shprf 1/4
3	56383502	1	Bracket-LED
4	56383503	1	Decal-Charger LED
5	56383586	1	Adapter-Charger DeltaQ Power
6	56383886	1	Adapter-Interlock
7	56383856	1	Charger-Onboard 24VDC 650W s NOTE 1 / NOTE 2
8	56383857	1	Indicator-Charge LED W/Temp
9	56383866	1	Cord-AC Nema IEC320 - DeltaQ
10	9095149000	1	Battery Cable Support
11	56009096	2	Wsh Flt .193X.875X.060
12	964004	2	Screw M5X16 PN ST PH
13	87026A	4	Washer .250 FLAT SS
14	56384043	1	Strain Relief Kit
[]	56478523	8	Tie-Cable

NOTE 1: The onboard battery charger is standard on model 56112780.

NOTE 2: The onboard battery charger 56112544 has been replaced in production by 56383856. If you need to replace 56112544 please order Onboard Charger Kit 56383869.

CHASSIS SYSTEM-DISK

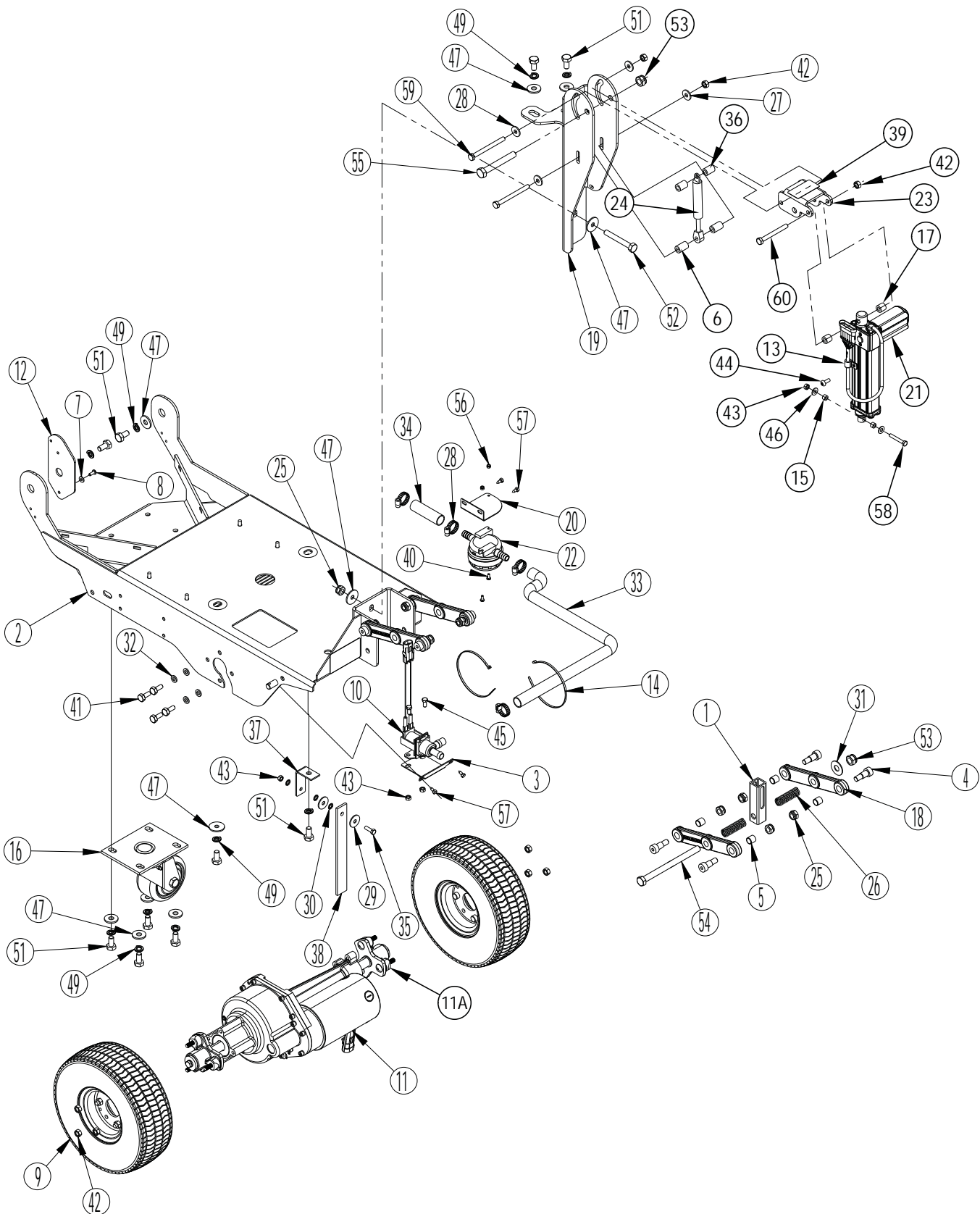

CHASSIS SYSTEM-DISK

Item	Ref. No.	Qty	Description	Item	Ref. No.	Qty	Description
1	56109717	1	Tube Jack Motor	31	980648	1	Washer 17/32 X 1 1/16 Plain
2	56112765	1	Chassis Weldt	32	980652	8	Washer, 5/16 Lock
3	61932A	1	Bracket, Solution Valve	33	30828A	1	Hose, Clear X25.00 Long
4	88617A	8	Screw, M10 x M12 x 16mm S.B.S.H.	34	30829A	1	Hose, Clear X 3.00 Long
5	56112548	8	Bushing	35	56003942	1	Scr-Hex SS M6-1 X 20MM
6	9096113000	2	Spacer	36	61937A	2	Spacer, .590od X .328id
7	56001954	1	Wsh, Flt SAE #10	37	61949A	1	Bracket, Ground Strap
8	56009029	1	Scr, Pan Phil Thd Form 10-24 X .50	38	69639A	1	Strap, Static
9	56112109	2	Tire	39	71017A	1	Label, Moving Parts
10	56112147	1	Solenoid Valve Assy (L1)	40	80057A	2	Screw, M4-.7x10
11	56112543	1	Transaxle	41	80183A	8	Bolt, M8-1.25 X 20, Hex
11a	56380158	2	Flange Kit (for 56112543)	42	80198A	9	Nut, M8 -1.25 Nylock S.S.
*	56382670	1	Kit Transaxle Motor (for 56112543) (M1)	43	80199A	4	Nut, M6 -1.00 Nylock S.S.
*	40628A	4	Carbon Brush (for 56112543)	44	80208A	1	Screw, M6 X 1.00 X 10mm Pan Head
12	56112768	1	Connector Brkt	45	56003211	2	Scr Hex Hd SS M6-1.0 X 12MM
13	56323260	1	Clamp, Hose Support	46	87026A	2	Washer, 1/4 Flat S.S.
14	56478523	1	Tie, Cable	47	87054A	10	Washer Fender .375
15	1462258000	2	Spacer 6.1 X 10 X 6.5	49	88612A	10	Washer, Lock M10
16	56112308	1	Caster, Rear	51	88614A	10	Screw, M10-1.5 X 20mm
17	9096112000	2	Spacer	52	88616A	1	Screw, Hex Hd M10x75
18	56382618	4	Lever Kit	53	88618A	2	Nut, M12 Nylon Insert
19	9097368000	1	Support, Jack Motor	54	88619A	1	Screw, Hex Hd M12x160
20	9097370000	1	Bracket, Filter	55	88620A	1	Screw, Hex Hd M12x90
21	40280A	1	Actuator (M2)	56	88623A	2	Nut, M4-.7 Nylock Insert
22	9100000362	1	Filter Water TSB-FC-2013-127	57	88624A	4	Screw, M5 X 12mm Hex Self Tap Tri-Lobe
*	9095215000	1	Filter and Seal (for 9100000362)	58	88626A	1	Screw M6-1 X 40mm Hex
23	9097456000	1	Lever	59	56003390	2	Screw, M8 X 90 Hex Head
24	54689A	1	Gas Spring 500n	60	88635A	1	Screw, M8 X75 Hex Head
25	80223A	9	Nut, M10-1.5 Nylock				
26	E04016	2	Spring				
27	170860	4	Washer, Flat 5/16				
28	722030	4	Clamp, Hose				
29	980205	2	Washer, .31 I.D. X 1.06 O.D.				
30	980614	3	Washer, 1/4" Starlock, External				

* = Optional, Not Included

CHASSIS SYSTEM-CYLINDRICAL

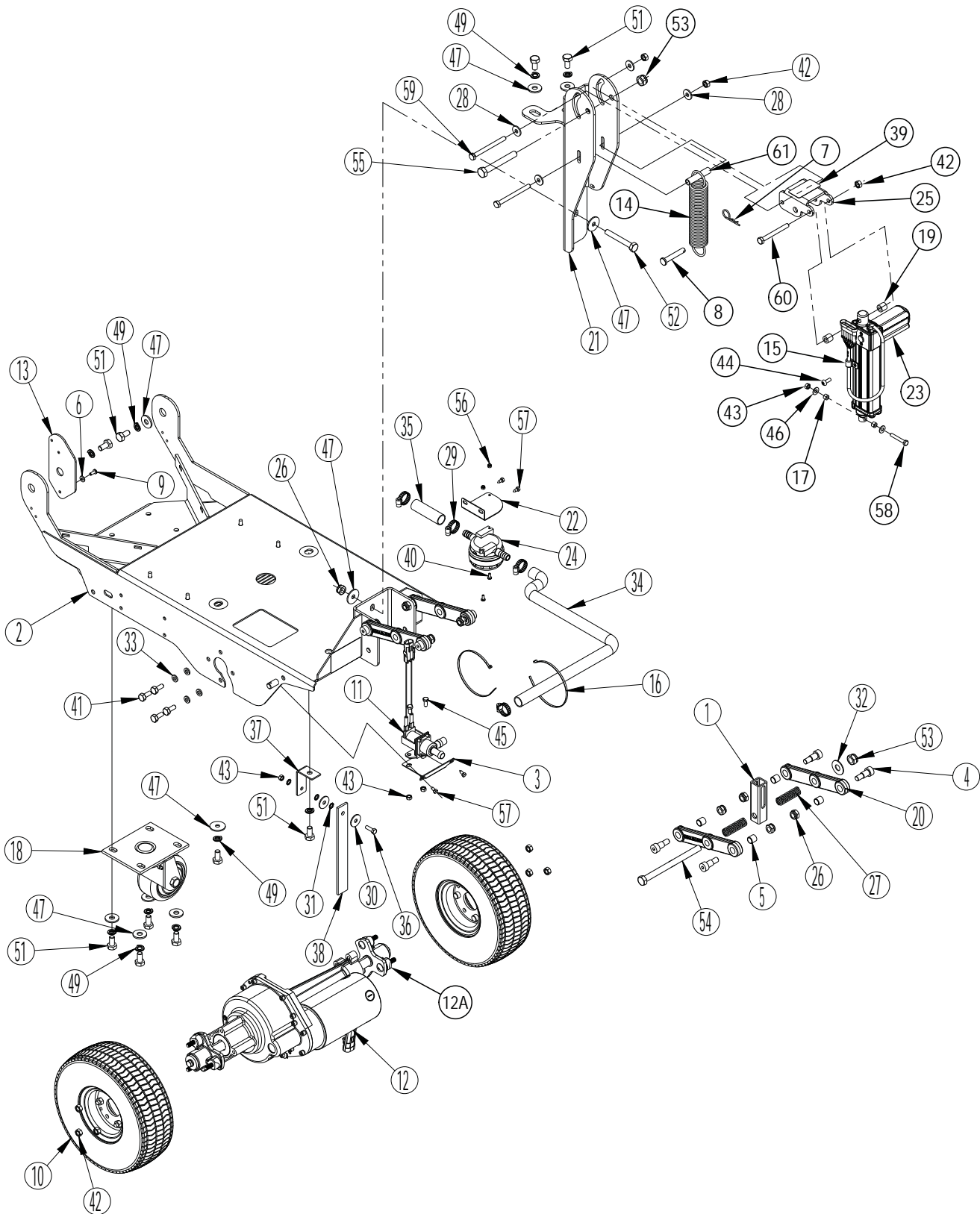

CHASSIS SYSTEM-CYLINDRICAL

Item	Ref. No.	Qty	Description	Item	Ref. No.	Qty	Description
1	56109717	1	Tube Jack Motor	31	980614	3	Washer, 1/4" Starlock, External
2	56112765	1	Chassis Weldt	32	980648	1	Washer 17/32 X 1 1/16 Plain
3	61932A	1	Bracket, Solution Valve	33	980652	8	Washer, 5/16 Lock
4	88617A	8	Screw, M10 x M12 x 16mm S.B.S.H.	34	30828A	1	Hose, Clear X25.00 Long
5	56112548	8	Bushing	35	30829A	1	Hose, Clear X 3.00 Long
6	56001954	1	Wsh, Flt SAE #10	36	56003942	1	Scr-Hex SS M6-1 X 20MM
7	56002959	1	Pin, Cotter Hair	37	61949A	1	Bracket, Ground Strap
8	56003656	1	Pin-Clevis .375 X 2.25	38	69639A	1	Strap, Static
9	56009029	1	Scr, Pan Phil Thd Form 10-24 X .50	39	71017A	1	Label, Moving Parts
10	56112109	2	Tire	40	80057A	2	Screw, M4-.7x10
11	56112147	1	Solenoid Valve Assy (L1)	41	80183A	8	Bolt, M8-1.25 X 20, Hex
12	56112543	1	Transaxle	42	80198A	9	Nut, M8 -1.25 Nylock S.S.
12a	56380158	2	Flange Kit (for 56112543)	43	80199A	4	Nut, M6 -1.00 Nylock S.S.
*	56382670	1	Kit Transaxle Motor (for 56112543) (M1)	44	80208A	1	Screw, M6 X 1.00 X 10mm Pan Head
*	40628A	4	Carbon Brush (for 56112543)	45	56003211	2	Scr Hex Hd SS M6-1.0 X 12MM
13	56112768	1	Connector Brkt	46	87026A	2	Washer, 1/4 Flat S.S.
14	56422075	1	Spring Extension	47	87054A	10	Washer Fender .375
15	56323260	1	Clamp, Hose Support	49	88612A	10	Washer, Lock M10
16	56478523	1	Tie, Cable	51	88614A	10	Screw, M10-1.5 X 20mm
17	1462258000	2	Spacer 6.1 X 10 X 6.5	52	88616A	1	Screw, Hex Hd M10x75
18	56112308	1	Caster, Rear	53	88618A	2	Nut, M12 Nylon Insert
19	9096112000	2	Spacer	54	88619A	1	Screw, Hex Hd M12x160
20	56382618	4	Lever Kit	55	88620A	1	Screw, Hex Hd M12x90
21	9097368000	1	Support, Jack Motor	56	88623A	2	Nut, M4-.7 Nylock Insert
22	9097370000	1	Bracket, Filter	57	88624A	4	Screw, M5 X 12mm Hex Self Tap Tri-Lobe
23	40280A	1	Actuator (M2)	58	88626A	1	Screw M6-1 X 40mm Hex
24	9100000362	1	Filter Water TSB-FC-2013-127	59	56003390	2	Screw, M8 X 90 Hex Head
*	9095215000	1	Filter and Seal (for 9100000362)	60	88635A	1	Screw, M8 X75 Hex Head
25	9097456000	1	Lever	61	56112520	1	Spacer
26	80223A	9	Nut, M10-1.5 Nylock				
27	E04016	2	Spring				
28	170860	4	Washer, Flat 5/16				
29	722030	4	Clamp, Hose				
30	980205	2	Washer, .31 I.D. X 1.06 O.D.				

* = Optional, Not Included

CHASSIS SYSTEM-REV

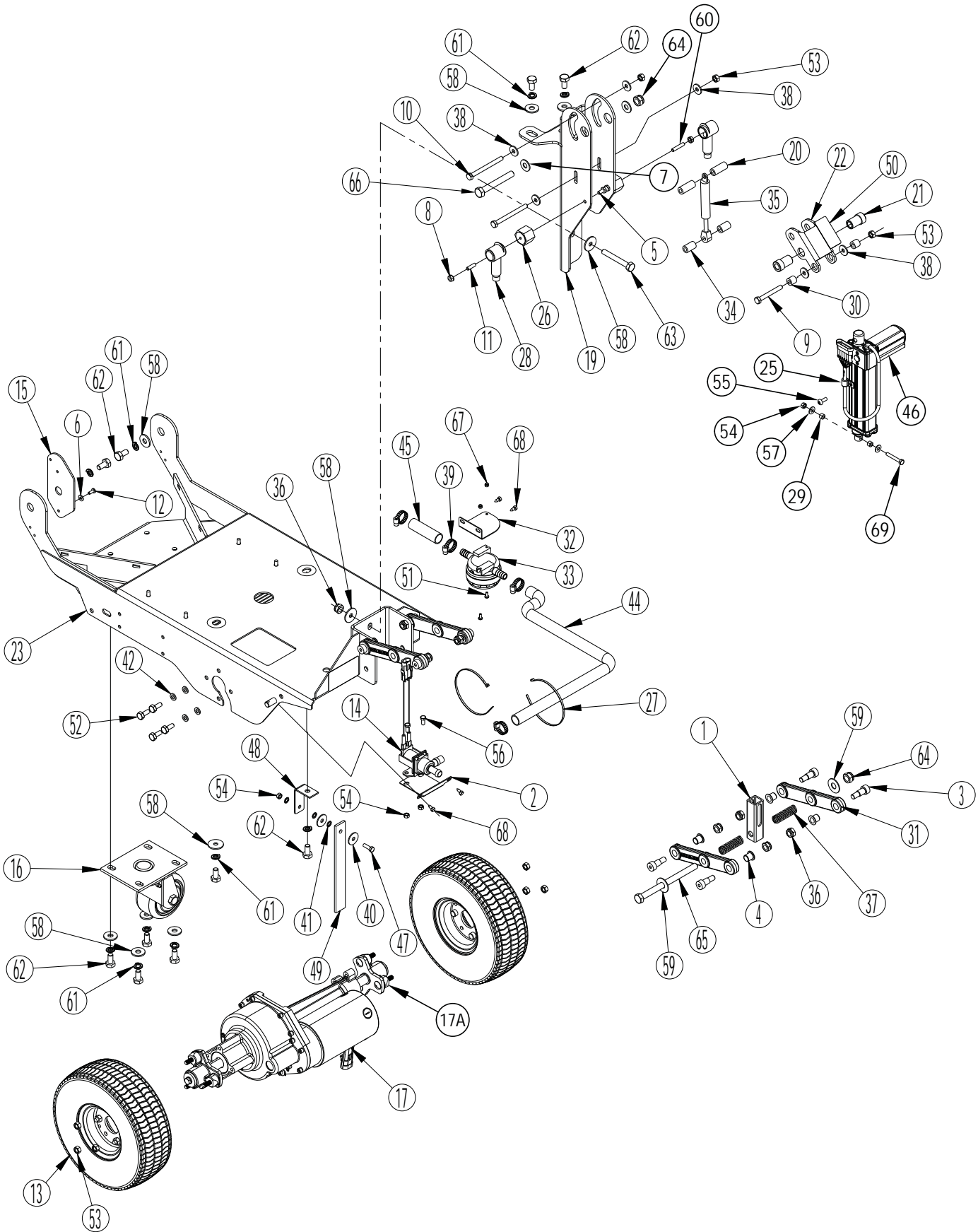

CHASSIS SYSTEM-REV

Item	Ref. No.	Qty	Description	Item	Ref. No.	Qty	Description
1	56109717	1	Tube Jack Motor	33	910000362	1	Filter Water TSB-FC-2013-127
2	61932A	1	Bracket, Solution Valve	*	9095215000	1	Filter and Seal (for 910000362)
3	88617A	8	Screw, M10 x M12 x 16mm S.B.S.H.	34	9096113000	2	Spacer
4	9097008000	8	Bush Flanged GFM1214-09	35	54689A	1	Gas Spring 500n
5	56001854	2	Scr-Hex 1/4-20 X .50	36	80223A	9	Nut, M10-1.5 Nylock
6	56001954	1	Wsh, Flt SAE #10	37	E04016	2	Spring
7	56002918	2	Wsh Flt SAE SS 1/2	38	170860	6	Washer, Flat 5/16
8	56002561	2	Nut, Hex W/ Shprf 1/4-20	39	722030	4	Clamp, Hose
9	88635A	1	Screw M8-1.25 X 75MM Hex	40	980205	2	Washer, .31 I.D. X 1.06 O.D.
10	56003390	2	Scr-Hex M8-1.25 X 90mm	41	980614	3	Washer, 1/4" Starlock, External
11	56009020	1	Stud	42	980652	8	Washer, 5/16 Lock
12	56009029	1	Scr, Pan Phil Thd Form 10-24 X .50	43	980657	4	Washer, Lock 1/4
13	56112109	2	Wheel	44	56266134	1	Hose Spiral .50 X 22.00
14	56112147	1	Solenoid Valve Assy	45	30829A	1	Hose, Clear X 3.00 Long
15	56112768	1	Connector Brkt	46	40280A	1	Actuator
16	56112308	1	Caster-Swivel 4.00 X 2.00	47	56003942	1	Scr-Hex SS M6-1 X 20MM
17	56112543	1	Transaxle	48	61949A	1	Bracket, Ground Strap
17A	56380158	2	Flange Kit (for 56112543)	49	69639A	1	Strap, Static
*	56382670	1	Kit Transaxle Motor (for 56112543) (M1)	50	71017A	1	Label, Moving Parts
*	40628A	4	Carbon Brush (for 56112543)	51	80057A	2	Screw, M4-.7x10
[18]	56383869	1	Kit-OBC SC750 NOTE 1	52	80183A	8	Bolt, M8-1.25 X 20, Hex
19	56112711	1	Lifting Support Weldt	53	80198A	9	Nut, M8 -1.25 Nylock S.S.
20	56112715	2	Spacer Nylon	54	80199A	4	Nut, M6 -1.00 Nylock S.S.
21	56112716	2	Spacer Nylon	55	80208A	1	Screw, M6 X 1.00 X 10mm Pan Head
22	56112719	1	Lever	56	56003211	2	Scr Hex Hd SS M6-1.0 X 12MM
23	56112765	1	Chassis Weldt	57	87026A	6	Washer, 1/4 Flat S.S.
[24]	56383866	1	Cord-AC NEMA IEC320 - DELTAQ	58	87054A	10	Washer Fender .375
25	56323260	1	Clamp, Hose Support	59	87607A	2	Washer, Nylon 1.25 X .52 X .06 Flat
26	56469858	2	Electrical Mount	60	56009203	1	Stud 1/4-20X1.31
27	56478523	10	Tie, Cable	61	88612A	10	Washer, Lock M10
28	56493357	2	Insulator, Terminal	62	88614A	10	Screw, M10-1.5 X 20mm
29	1462258000	2	Spacer 6.1 X 10 X 6.5	63	88616A	1	Screw, Hex Hd M10x75
30	9096112000	2	Spacer	64	88618A	2	Nut, M12 Nylon Insert
31	56382618	4	Lever Kit	65	88619A	1	Screw, M12-1.75 X 160mm Hex
32	9097370000	1	Bracket, Filter	66	88620A	1	Screw, Hex Hd M12x90
				67	88623A	2	Nut, M4-.7 Nylock Insert
				68	88624A	4	Screw, M5 X 12mm Hex Self Tap Tri-Lobe
				69	88626A	1	Screw M6-1 X 40mm Hex

[] = Not Shown

NOTE 1: The onboard battery charger 56112544 has been replaced in production by 56383856. If you need to replace 56112544 please order Onboard Charger Kit 56383869.

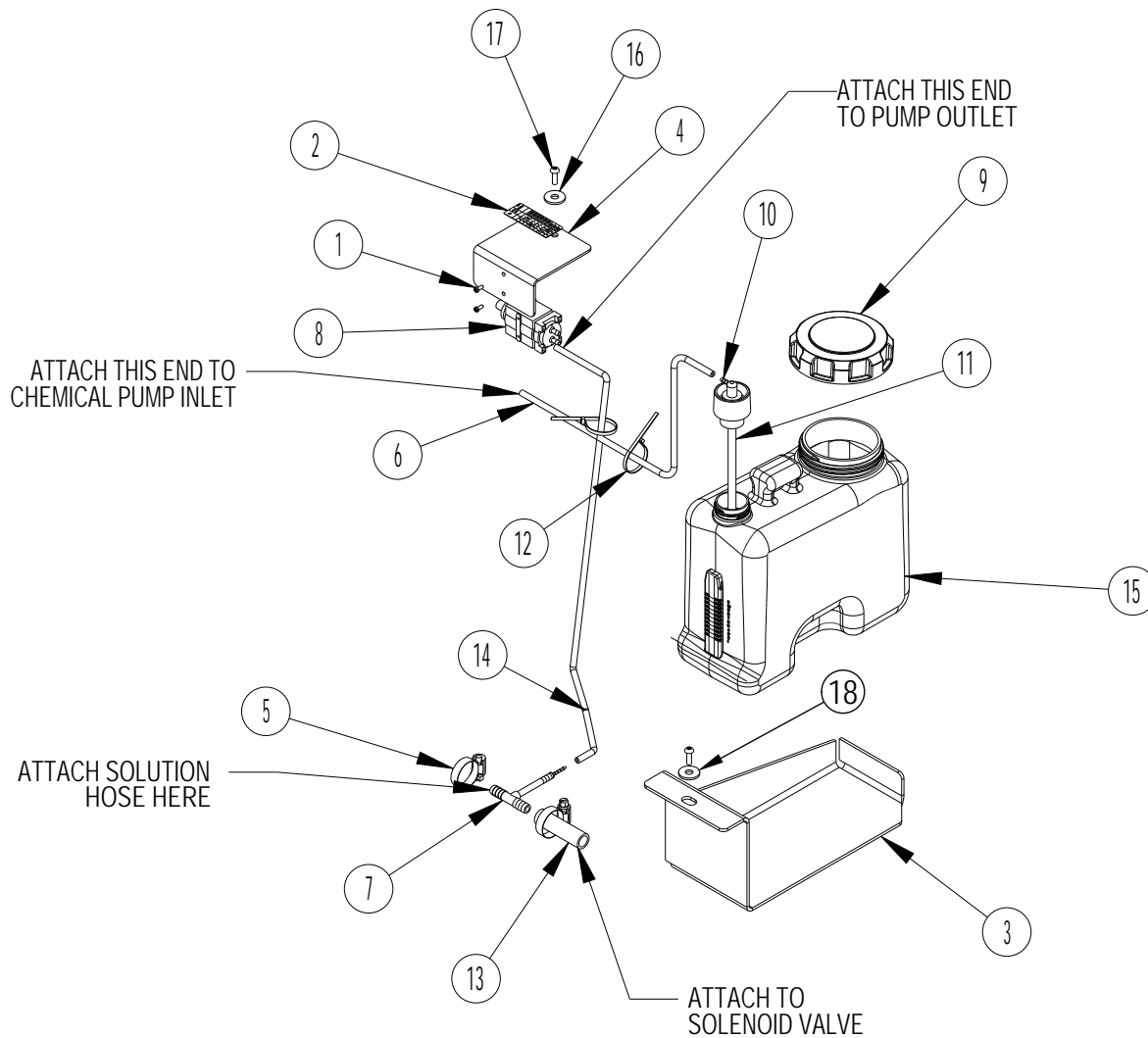

DETERGENT INJECTION SYSTEM-ECOFLEX™

Item	Ref. No.	Qty	Description
1	56002539	2	Scr, Pan Phil Thd Form 6-32 X .31
2	56016331	1	Decal-Chemical Ratio
3	56112125	1	Bracket-Bottle Support
4	56112126	1	Bracket-Pump Mount
5	722030	2	Clamp- Hose
6	56306169	1	Hose, Chem Resistant, 17.00
7	56314983	1	Tee Assembly
8	56315241	1	Pump-Chemical (M6)
9	56315517	1	Cap, Raw
10	56315523	1	Cap, Dry Break, 1/8 Barb, 90°
11	56315527	1	Insert, Dry Break
12	56325219	2	Tie, Cable
13	56392347	1	Hose, PVC Clear 2.5 Inch
14	56413692	1	Hose, Chem Resistant, 21.00
15	56601544	1	Chemical Bottle Assy
*	56601545	1	Chemical Bottle Assy (Includes 9, 11 & 15)
16	56002098	1	Wsh-Flat SAE 1/4
17	56003627	2	Scr-Pan Phil M6-1 X 16mm
18	56009060	1	Wsh Flt SS .260X1.000X.074

* = Optional, Not Included

NOTE: Detergent Injection is standard on model 56112780.

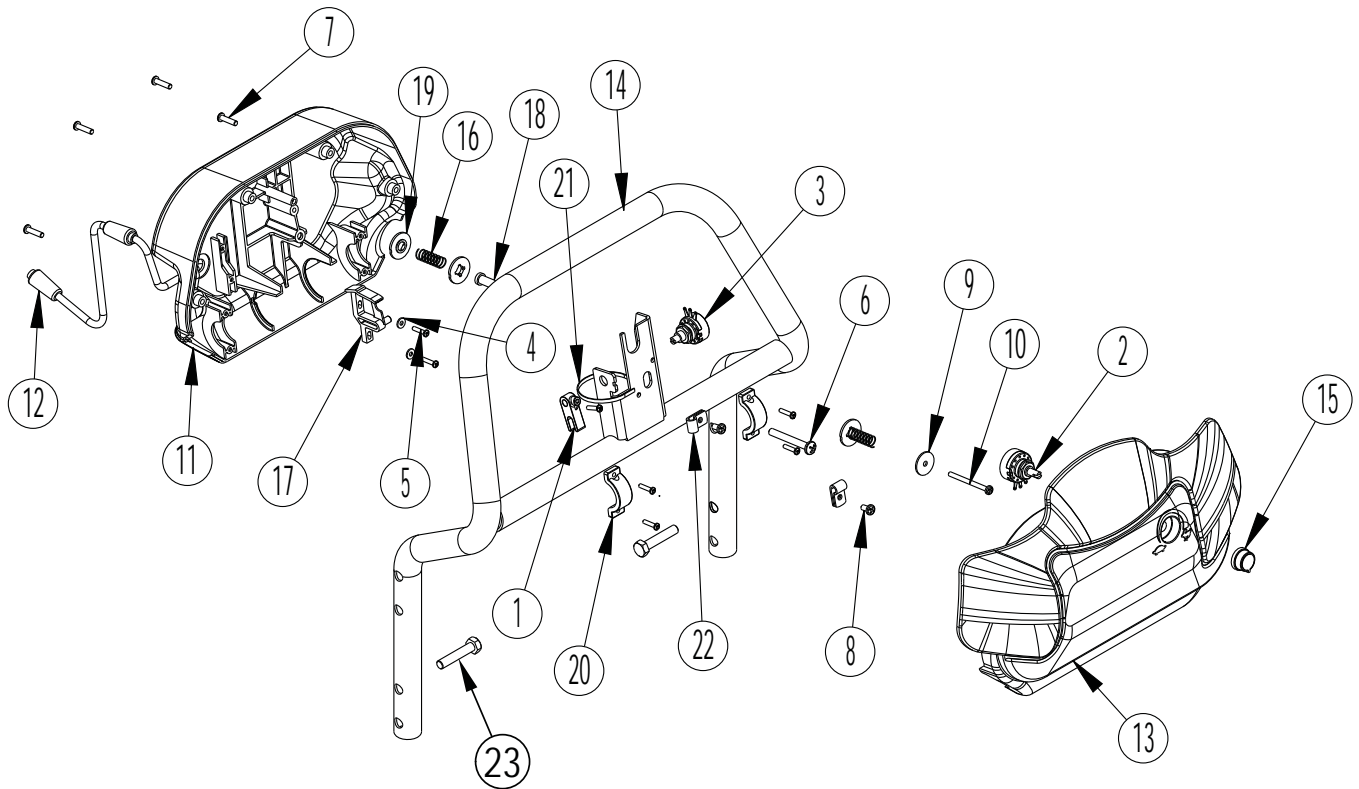

CONTROL SYSTEM-SC750, SC800

Item	Ref. No.	Qty	Description
	56112218	1	Paddle Assembly (1-22) NOTE 1
	56383361	1	Paddle Assembly (1-22) NOTE 2
1	56109648	1	Potentiometer Fork
2	56396197	1	Potentiometer-Speed Limit (R2)
3	56397029	1	Potentiometer-5k (R1)
4	56002006	2	Wsh, Flt SAE #6
5	56003197	7	Scr, Pan Phil Plastite 6-18 X .62
6	56003527	1	Scr, Pan Phil Plastite 1/4-1 X 2.00
7	56003545	4	Scr, Pan Phil Plastite 8-10 X .75
8	56009030	2	Scr, Pan Phil Thd Form 10-24 X .38
9	56009096	1	Wsh, Flt .193 X .875 X .060
10	56009287	1	Scr, Pan Phil Type B 8 X 2.00
11	56109716	1	Paddle-Back Cover
12	56112179	1	Harness-Paddle NOTE 1
	56383358	1	Harness-Paddle NOTE 2
13	56315230	1	Paddle, Front Cover
14	56112767	1	Weldment-Handle Bar
15	56315280	1	Knob
16	56325654	2	Spring - Compression
17	56397015	1	Cam Controller
18	56397109	1	Sleeve
19	56397170	3	Washer, Plastic
20	56397171	2	Clamp
21	56478246	1	Tie, Cable
22	56481890	2	Clamp-P
23	56002094	4	Scr-Hex 5/16-18 x 1.50

NOTE 1: Only used on machines before serial number 4000068715.

NOTE 2: Only used on machines after serial number 4000068714.

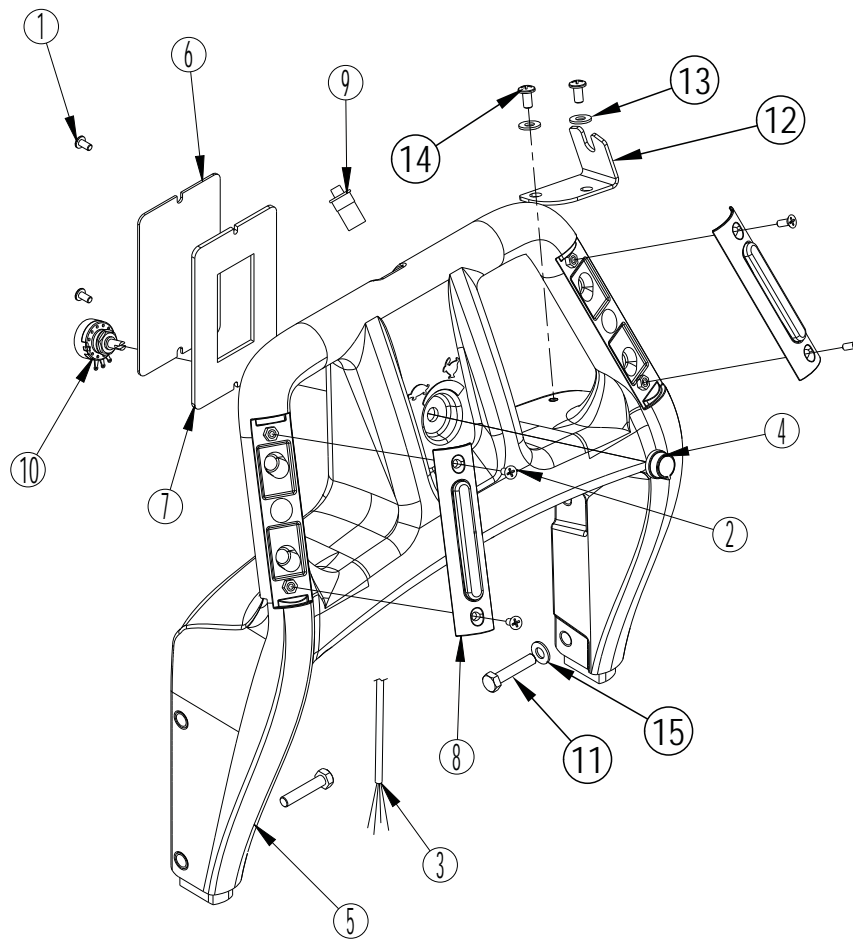

CONTROL SYSTEM-SC750 ST, SC800 ST

Item	Ref. No.	Qty	Description
	56112219	1	Handle Assembly (1-10) NOTE 1
	56383382	1	Handle Assy (1-10) NOTE 2
1	56002043	2	Scr-Pan Phil 10-24 X .38
2	56002178	4	Scr, Flt Phil 10-24 X .50
3	56112186	1	Harness-Handle NOTE 1
	56383368	1	Harness-Handle NOTE 2
4	56315280	1	Knob
5	56315931	1	Handle, Rotomold
6	56315932	1	Access Plate
7	56315933	1	Gasket, Access Panel
8	56315935	2	Palm Switch Assembly (S4 / S5)
9	56315945	1	Switch, Spst Mom. (S6)
10	56315929	1	Potentiometer-Speed Limit (R2)
11	56003437	4	Scr-Hex SS M8-1.25 x 40mm
12	56112769	1	Squeegee Holder
13	56002098	2	Wsh-Flt SAE 1/4
14	56002145	2	Scr-Pan Phil 1/4-20 x .50
15	56001939	4	Wsh-Flt SAE 5/16

NOTE 1: Only used on machines before serial number 4000068715.

NOTE 2: Only used on machines after serial number 4000068714.

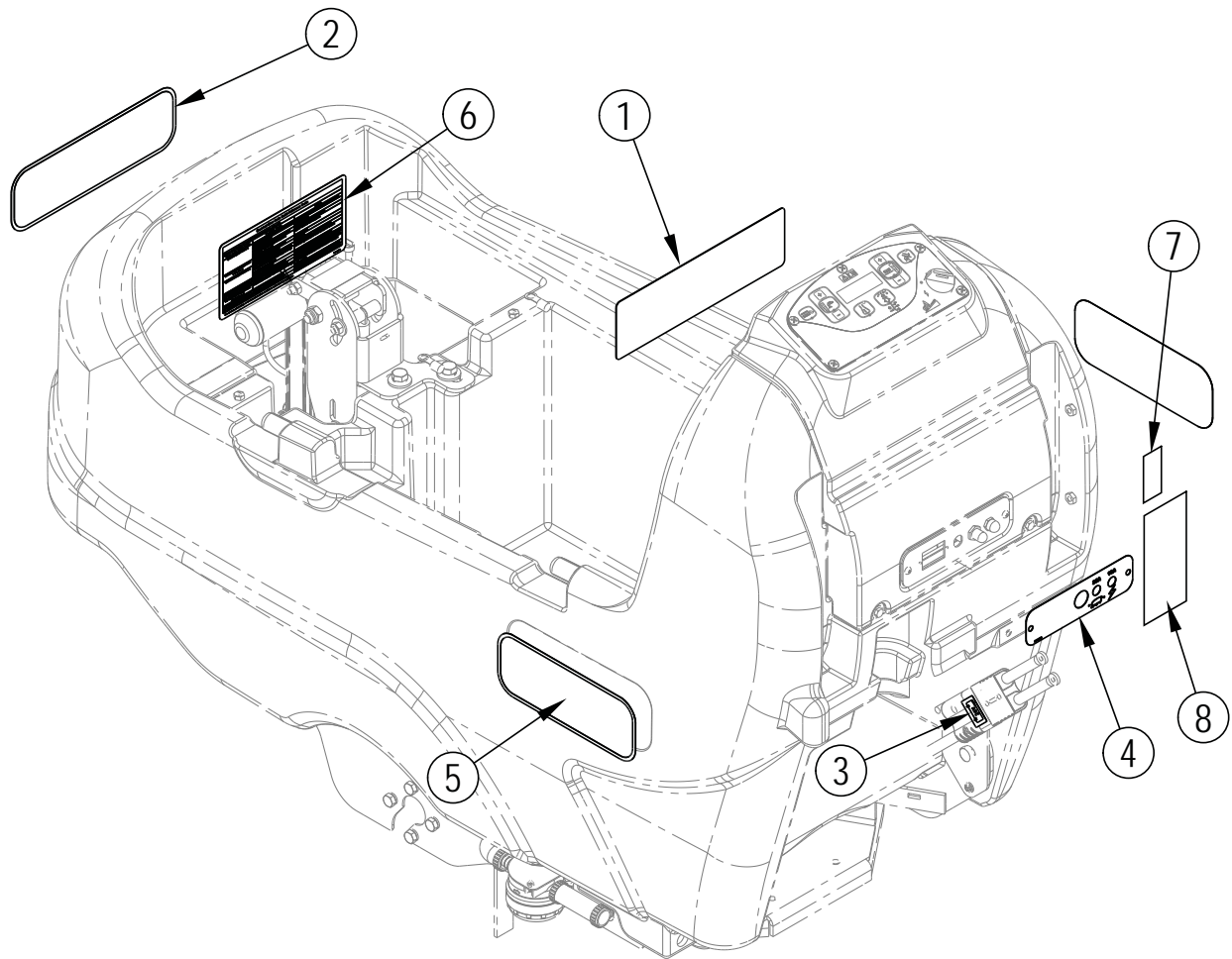

DECAL SYSTEM

Item	Ref. No.	Qty	Description
1	56014601	1	Decal, Caution
2	56016730	1	Decal-Advance
3	56054192	1	Decal, Charger
4	56112168	1	Decal-Circuit Breaker
5	56112525	2	Decal-SC750
	56112526	2	Decal-SC800
	56112527	2	Decal-SC750 ST
	56112528	2	Decal-SC800 ST
	56112529	2	Decal-SC750 EcoFlex
	56112530	2	Decal-SC800 EcoFlex
6	56112292	1	Decal-Error Codes
7	71362A	1	Decal-NFSI
8	56112539	1	Decal-Warning/Wiring

ELECTRICAL SYSTEM-SC750, SC800

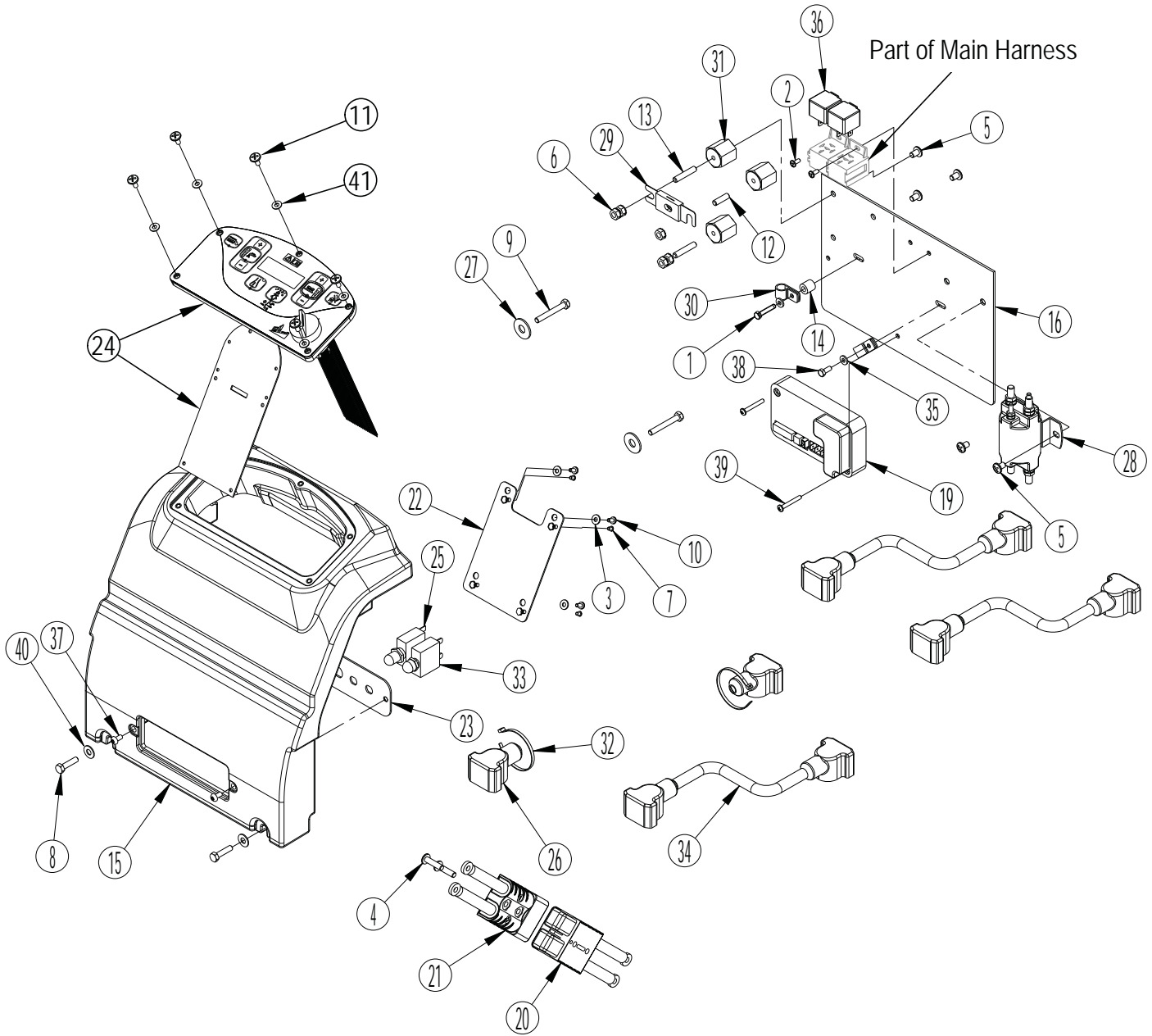

ELECTRICAL SYSTEM-SC750, SC800

Item	Ref. No.	Qty	Description
1	33003964	1	Screw, Hex Thd To Hd M5x25
2	56001818	2	Scr-Pan Phil 8-32 X .38
3	56002140	4	Wsh, Flt SAE #8
4	56002292	2	Scr-Pan Phil 1/4-20 X 1.00
5	56002462	5	Scr-Pan Phil 1/4-20 X .38
6	56002561	5	Nut, Hex W/ Shprf 1/4-20
7	56003336	4	Scr-Pan Phil Blk 6-32 X .19
8	56003430	2	Scr-Hex SS M6-1 X 25mm
9	56003631	2	Scr-Hex M6-1 X 45mm
10	56003653	4	Scr-Pan Phil M4-0.7 X 8mm
11	56003808	5	Scr- Truss Phil Blk M5-0.8 X 12mm
12	56009020	1	Stud
13	56009203	2	Stud, 1/4-20
14	56046309	1	Spacer, Phenolic
15	56112112	1	Control Panel
16	56112115	1	Electrical Panel
[17]	56112169	1	Cable-Jumper
[18]	56112174	1	Harness-Main NOTE 2
	56383891	1	Harness-Main NOTE 3
19	56112187	1	Speed Controller 70a 24v (A2)
20	56112188	1	Connector Assy
21	56112189	1	Connector Assembly
22	56112535	1	Bracket-Pcb Mount
23	56112540	1	Plate-Circuit Breaker NOTE 1, NOTE 2
	56383359	1	Plate-Circuit Breaker NOTE 3
24	56112351	1	Kit AXP Control Board
[]	56303553	1	Switch-Key (S3)
*	56303526	1	Replacement Key Set (for 56303553)
*	56112253	1	Kit-Interface Panel (Membrane Switch, Membrane Panel, Gasket)
25	56315256	1	Circuit Breaker, 30 Amp (CB1)
26	56372673	2	Boot-Battery Post
27	56385358	2	Washer
28	56397088	1	Contact, 24v Spdt (K2)
29	56412089	1	Fuse, 150 Amp (F1)
30	56442011	2	Clamp-P
31	56469858	3	Electrical Mount
32	56478246	2	Tie, Cable
33	56507644	1	Circuit Breaker, 10 Amp (CB2)
34	40172A	3	Cable, Battery
35	980643	2	Washer 7/16 Od X .036 Thk
36	41075A	2	Relay, 40a (K1 / K3)
37	80193A	2	Screw, M5 X 0.8 X 10mm P.H.
38	80249A	1	Screw, Hex Thd To Hd M5 x 12
39	80380A	2	Screw, 8-32 X 1 1/4" P.H.
40	87026A	2	Washer, 1/4 Flat S.S.
41#	56384075	5	Washer-Black Nylon-6/6

[] = Not Shown

* = Optional, Not Included

= Revised or new since last update

NOTE 1: Circuit Breaker Plate 56112122 is obsolete and has been replaced by 56112540.**NOTE 2:** Only used on machines before serial number 4000068715.**NOTE 3:** Only used on machines after serial number 4000068714.

ELECTRICAL SYSTEM-SC750 ST, SC800 ST

Item	Ref. No.	Qty	Description
1	56001818	2	Scr-Pan Phil 8-32 X .38
2	56002292	2	Scr-Pan Phil 1/4-20 X 1.00
3	56002462	5	Scr-Pan Phil 1/4-20 X .38
4	56002561	5	Nut, Hex W/ Shprf 1/4-20
5	56003430	2	Scr, Hex Ss M6-1 X 25mm
6	56003631	2	Scr, Hex M6-1 X 45mm
7	56003808	5	Scr- Truss Phil Blk M5-0.8 X 12mm
8	56003336	4	Scr-Pan Phil Blk 6-32 x .19
9	56003653	4	Scr-Pan Phil M4-0.7 x 8mm
10	56009020	1	Stud
11	56009203	2	Stud, 1/4-20
12	56112112	1	Control Panel
13	56112115	1	Electrical Panel
14	56112352	1	Kit ST Control Board
[]	56112190	3	Switch-Momentary Rocker (S7 / S8 / S9)
[]	56303553	1	Switch-Key (S3)
*	56303526	1	Replacement Key Set (for 56303553)
*	56112254	1	Kit-Interface Panel ST (Membrane Switch, Membrane Panel, Gasket)
15	56112540	1	Plate-Circuit Breaker NOTE 1, NOTE 2
	56383359	1	Plate-Circuit Breaker NOTE 3
[17]	56112169	1	Cable-Jumper
[18]	56112174	1	Harness-Main NOTE 2
	56383891	1	Harness-Main NOTE 3
19	56112188	1	Connector Assy
20	56112189	1	Connector Assembly
21	56112241	1	Speed Controller 70a 24v (A2)
22	56315256	1	Circuit Breaker, 30 Amp (CB1)
23	56372673	2	Boot-Battery Post
24	40172A	3	Cable, Battery
25	56412089	1	Fuse, 150 Amp (F1)
26	56469858	3	Electrical Mount
27	56478246	2	Tie, Cable
28	56507644	1	Circuit Breaker, 10 Amp (CB2)
29	980643	2	Washer 7/16 Od X .036 Thk
30	41075A	1	Relay, 40a (K1)
31	56412179	1	Contacto 24 VDC (K2)
32	80193A	2	Screw, M5 X 0.8 X 10mm P.H.
33	80249A	2	Screw, Hex Thd To Hd M5x12
34	80380A	2	Screw, 8-32 X 1 1/4" P.H.
35#	56009002	2	Washer Flat .266x.906x.060
36	87026A	2	Washer, 1/4 Flat S.S.
37	56112535	1	Bracket-PCB Mount
38	56002140	4	Wsh-Flt SAE 8
39#	56384075	5	Washer-Black Nylon-6/6

[] = Not Shown

* = Optional, Not Included

= Revised or new since last update

NOTE 1: Circuit Breaker Plate 56112122 is obsolete and has been replaced by 56112540.**NOTE 2:** Only used on machines before serial number 4000068715.**NOTE 3:** Only used on machines after serial number 4000068714.

RECOVERY SYSTEM

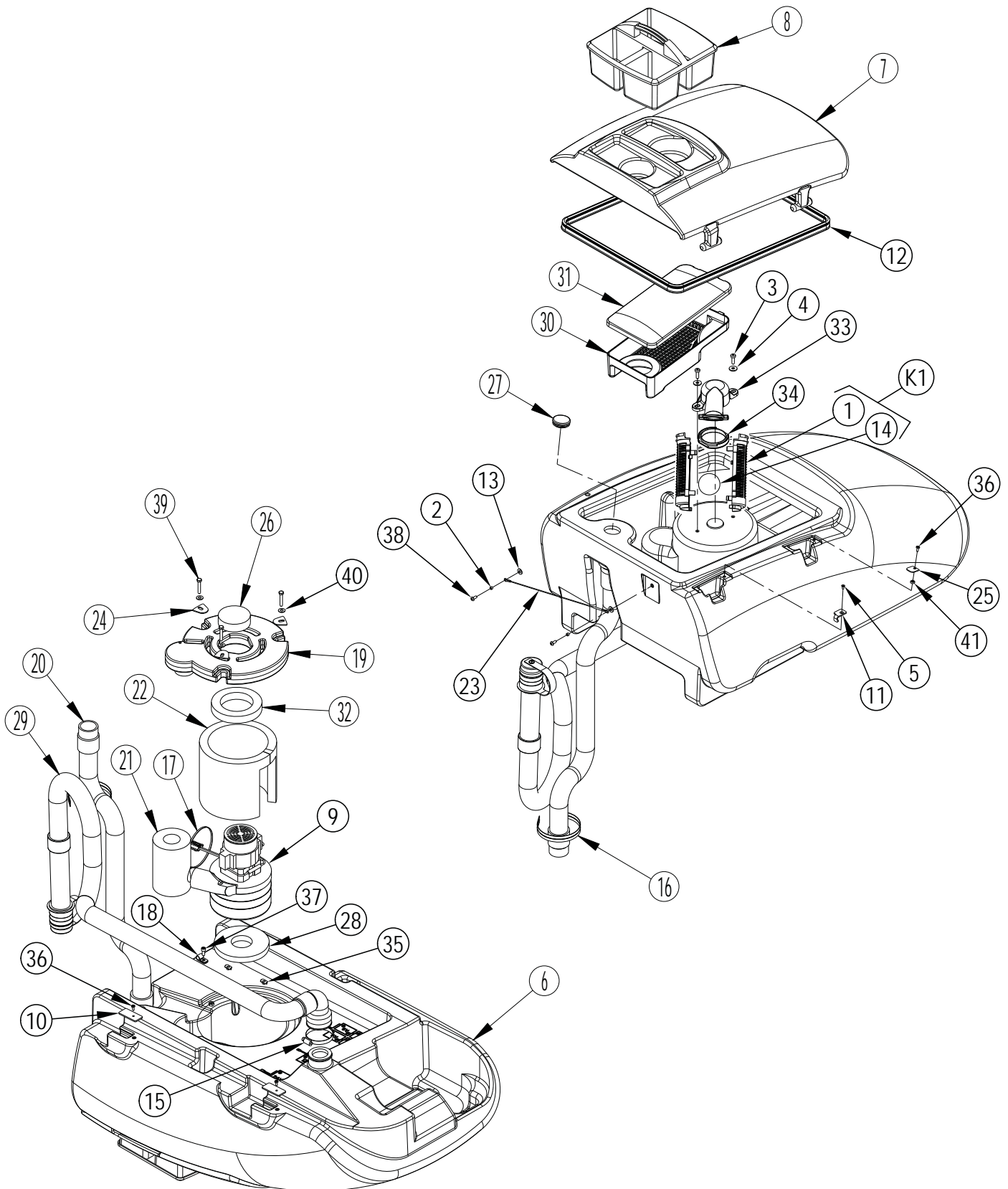

RECOVERY SYSTEM

Kit	Item	Ref. No.	Qty	Description	
K1	1		2	Cage, Float	
	2	56002053	2	Wsh, Flt Std #10	
	3	56003896	2	Scr-Pan Phil SS M6-1.0 X 20MM	
	4	56003638	2	Wsh, Flt SS 6mm	
	5	56003823	1	Scr-Flt Phil SS M4-0.7 X 8mm	
	6	56112106	1	Recovery Tank (SC750 models)	
		56112102	1	Recovery Tank (SC800 models)	
	7	56112107	1	Recovery Lid (SC750 models)	
		56112103	1	Recovery Lid (SC800 models)	
	8	56112222	1	Utility Caddy	
	9	56112239	1	Vac Motor-24 Vdc (M5)	
	*	56382640	1	Carbon Brush Set of 2 (for 56112239)	
	10	56112293	2	Retainer Plate	
	11	56112296	1	Retainer Plate	
	12	56112297	1	Gasket-Recovery Lid	
	13	56151092	2	Bushing	
	K1	14		1	Ball, Float
		15	56440213	2	Clamp- Hose SAE #32
		16	56477613	2	Tie, Cable
		17	56478523	1	Tie, Cable
18		56323260	2	Clamp-P	
19		9096051000	1	Vacuum Motor Cover	
20		56112316	1	Suction Hose	
21		9096442000	1	Insulation Tube	
22		9096491000	1	Panel, Acoustic Insulation	
23		9096634000	1	Stop Tank Cable	
24		9096638000	3	Vacuum Cover Plate	
25		9096643000	1	Tank Cover Plate	
26		56344168	1	Filter	
27		9096899000	1	Cap - Tank	
28		9096918000	1	Gasket Vacuum Motor	
29		56112310	1	Drain Hose-Recovery	
30		9097384000	1	Debris Tray	
31		9097477000	1	Debris Tray Cover	
32		9097555000	1	Gasket, Vacuum Motor	
33		9097587000	1	Support Float System	
34#		910000928	1	Gasket Float Support Pkd	
35	9097589000	2	Nut Drivin 6x6 SS		
36	80057A	3	Screw, M4-.7x10		
37	80208A	2	Screw M6-1 X 10mm P.P.Hd		
38	80363A	2	Screw M5-.8x12 Bt		
39	80410A	3	Screw, 6mm X 1.00 X 35mm Lg Hex		
40	87026A	3	Washer, 1/4 Flat S.S.		
41	9096679000	1	Spacer		

Service Kits

Item	Ref. No.	Qty	Description
K1	56112303	1	Kit-Float Ball Cage

* = Optional, Not Included

= Revised or new since last update

SCRUB SYSTEM-DISK

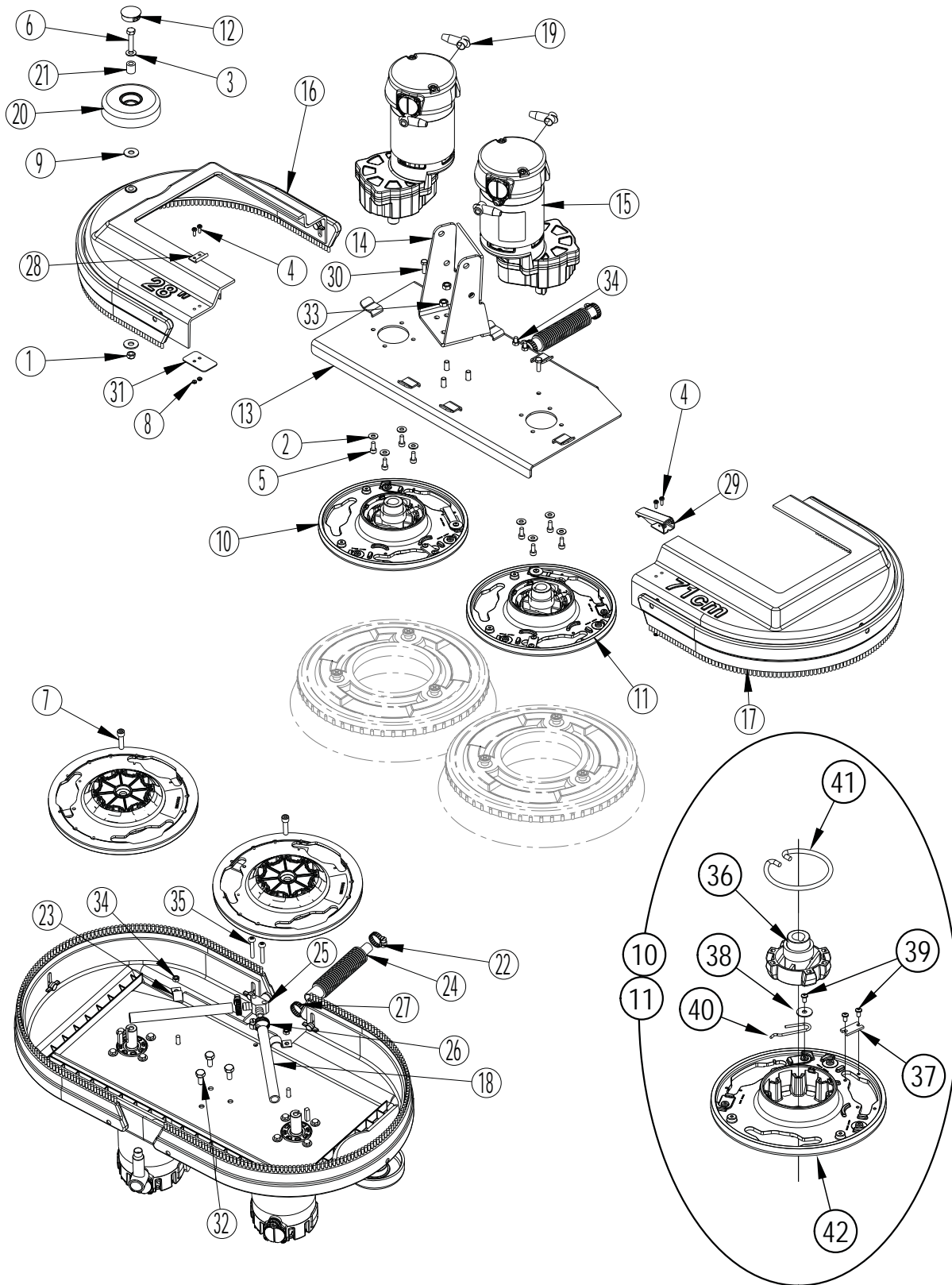

SCRUB SYSTEM-DISK

Item	Ref. No.	Qty	Description
1	56002851	1	Nut, Hex Nyl Loc-Thin SS 5/16-18
2	56002859	8	Wsh, Flt SAE SS 1/4
3	56002938	1	Wsh, Flt SAE SS 5/16
4	56003948	4	Scr-Pan Phil SS M4-0.7 X 12MM
5	56003425	8	Scr Soc SS M6-1X14MM
6	56003455	1	Scr- Hex SS 5/16-18 X 1.50
7	56003798	2	Scr, Soc Hd 5/16-18 X 1.25 Zinc Plated
8	56003949	4	Nut-Hex Nyl Loc SS M4-0.7
9	56009213	2	Wsh, Flt .392x1.00x.075
10	56109651	1	Brush Plate Assy – CCW (36-43)
11	56109652	1	Brush Plate Assy – CW (36-43)
12	56111444	1	Button Plug-1.25
13	56112757	1	Brush Plate Weldt 26D (26" models)
[]	56112758	1	Brush Plate Weldt 28D (28" models)
[]	56112759	1	Brush Plate Weldt 34D (34" models)
14	56112523	1	Linkage Bracket
15	56112240	2	Motor Gearbox Assy (M3 / M4)
*	56112242	2	Carbon Brush (for 56112240)
16	56112257	1	Brush Skirt Assy-26D Left (26" models)
16	56112259	1	Brush Skirt Assy-28D Left (28" models)
16	56112261	1	Brush Skirt Assy-34D Left (34" models)
17	56112258	1	Brush Skirt Assy-26D Right (26" models)
17	56112260	1	Brush Skirt Assy-28D Right (28" models)
17	56112262	1	Brush Skirt Assy-34D Right (34" models)
[]	56112305	1	Kit-Bristle Skirt 26 (26" models / Includes two skirts and mounting hardware)
[]	56112306	1	Kit-Bristle Skirt 28 (28" models / Includes two skirts and mounting hardware)
[]	56112307	1	Kit-Bristle Skirt 34 (34" models / Includes two skirts and mounting hardware)
18	34705A	2	Hose-Solution 6.00 (26" models)
	56397207	2	Hose, PVC Clear 7.00 (28" models)
	30453A	2	Hose-Clear Vinyl (34" models)
19	56409538	4	Terminal Insulator (28" & 34" models)
20	56601450	1	Wheel, 4.00 OD
21	56601499	1	Bushing, Nylon
22	722030	1	Clamp, Hose
23	782002	2	Clamp, Manifold
24	30412A	1	Hose, Solution
25	38014A	1	Splitter, Solution
26	50248A	2	Clamp, Hose
27	53571A	1	Clamp, Hose
28	55451A	1	Keeper, Latch
29	55721A	1	Latch, Southco 91-512-07
30	56003942	2	Scr-Hex SS M6-1 X 20MM
31	69186A	1	Tab, Latch, Brush
32	56003435	3	Scr Hex SS M8-1.25X20MM
33	80198A	3	Nut, M8 -1.25 Nylock S.S.
34	80199A	4	Nut, M6 -1.00 Nylock S.S.
35	56003950	2	Scr-Pan Phil SS M6-1.0 X 35MM
36	56112521	1	Gimbal Assembly
37	56366455	1	Plate, Stop
38	56009002	1	Wsh, Flt .266 x .906 x .060
39	56009247	3	Scr, Pan Phil Plastite 10-14 x .38
40	56109653	1	Spring Retainer
41	56601056	1	Spring, Brush Holder
42	56601118	1	Brush Plate

[] = Not Shown

* = Optional, Not Included

SCRUB SYSTEM-CYLINDRICAL

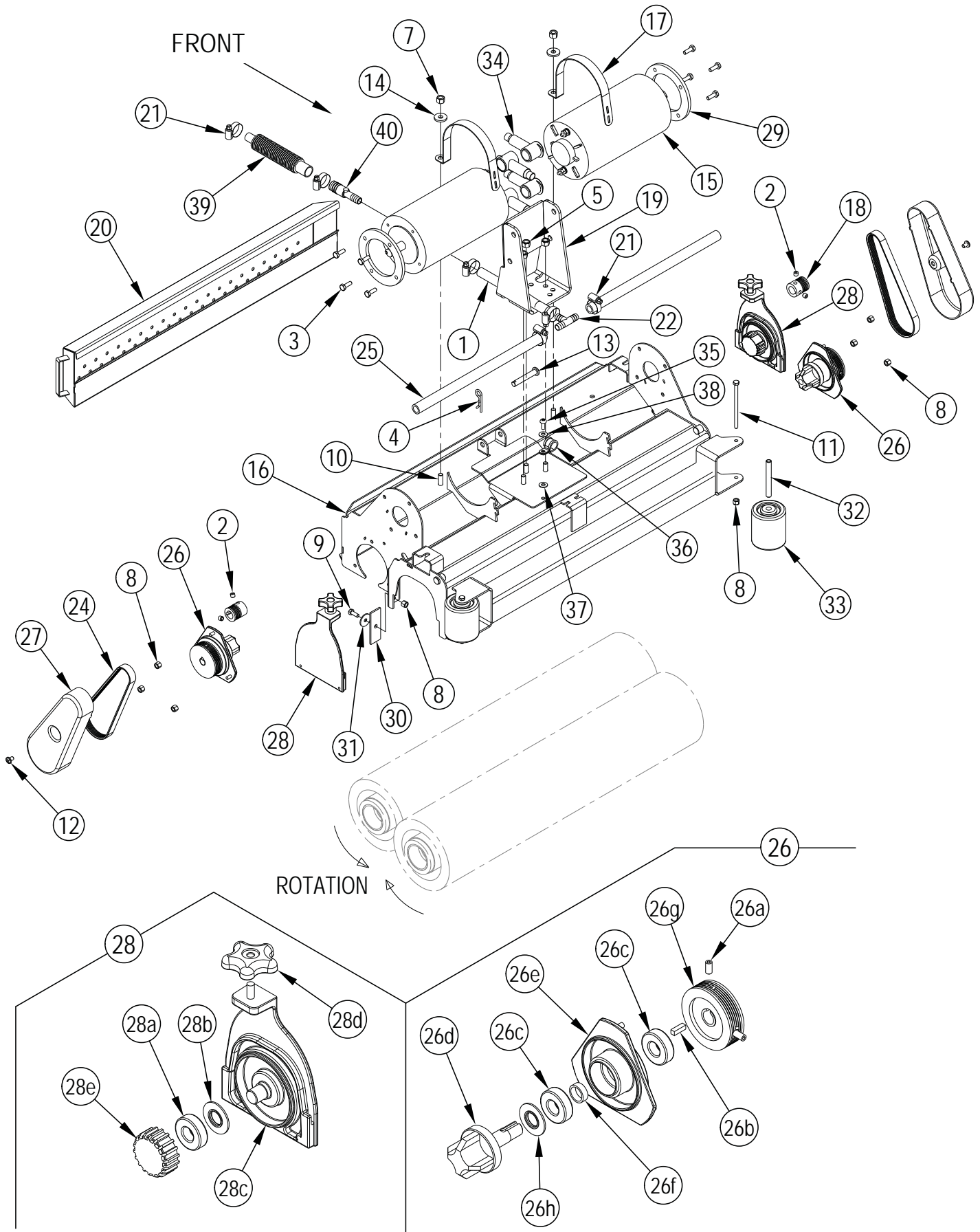

SCRUB SYSTEM-CYLINDRICAL

Item	Ref. No.	Qty	Description
1	56397207	1	Hose
2	56002086	4	Scr, Soc Set Loc 5/16-18 X .25
3	56002948	8	Scr,Hex Hd Loc 1/4-20x.75
4	56003222	1	Pin, Cotter Hair
5	56003389	3	Nut-Hex Nyl Loc M8-1.25
7	56003405	2	Nut, Hex Nyl Loc SS M8-1.25
8	56003426	10	Nut, Hex Nyl Loc SS M6-1
9	56003431	2	Scr, Hex SS M6-1 X 16mm
10	56003436	2	Scr, Hex SS M8-1.25 X 25mm
11	56003939	2	Scr-Hex SS M6-1 X 95MM
12	56003603	2	Scr, Pan Phil Thd Form 1/4-20 X .38
13	56003656	1	Pin-Clevis .375 X 2.25
14	56009122	2	Wsh, Flt .344 X .938 X .125
15	56112111	2	Motor-24 Vdc 3/4hp (M3 / M4)
*	56412257	1	Brush Cap Assy (for 56112111)
16	56112760	1	Brush Housing Weldt-28 (28" models)
	56112761	1	Brush Housing Weldt-32 (32" models)
17	56112165	2	Strap-Motor
18	56112166	2	Sheave-Poly-V
19	56112523	1	Linkage Bracket
20	56112762	1	Hopper Weldt-28 (28" models)
	56112763	1	Hopper Weldt-32 (32" models)
21	56112771	6	Clamp- Hose SAE #10
22	56262549	1	Tee, Barb
24	56315321	2	Belt, Auto Tension
25	56315355	2	Manifold, PVC 28 (28" models)
	56315647	2	Manifold, PVC 32 (32" models)
26	56407559	2	Drive End Assy
26a#	56002119	2	Scr, Soc Set Loc 1/4-20 x .50
26b#	56003237	1	Key, Sq .19 x .62
26c#	56106070	2	Bearing, Ball
26d#	56109527	1	Spindle
26e#	56381765	1	Bearing, Plate
26f#	56407389	1	Spacer
26g#	56407442	1	Sheave, Poly-V
26h#	56407558	1	Washer, Bearing
27	56315445	2	Cover, Belt
28	56314445	2	Idler End Assy
28a#	56106070	1	Bearing, Ball
28b#	56407558	1	Washer, Bearing
28c#	56315447	1	Idler Bearing Plate
28d#	56407303	1	Knob
28e#	56407551	1	Hub NOTE 1
29	56316197	2	Plate, Motor Spacer
30	56407391	2	Blade
31	56009060	2	Wsh Flt SS .260X1.000X.074
32	56412176	2	Bushing
33	56412459	2	Wheel
34	56409538	4	Terminal Insulator
35	56002066	1	Scr Pan Phil 1/4-20 X .62
36	54779A	1	Clamp P 5/8 Steel
37	56009064	1	Wsh Int Shprf 1/4
38	87026A	1	Washer, 1/4 Flat S.S.
39	30412A	1	Hose-Solution
40	56315625	1	Barb-Coupler 1/2 x 3/4

[] = Not Shown

* = Optional, Not Included

= Revised or new since last update

NOTE 1:# Customers with Idler Hub making noise, order optional Idler W/O-Ring Kit 56384137.

SCRUB SYSTEM-REV

				Service Kits				
Kit	Item	Ref. No.	Qty	Description	Item	Ref. No.	Qty	Description
K6	1		4	Helical Spring Lock Washer Washer Lock 1/4	K1	56112740	1	Kit-Isolator
K6	2		1	Scr- Hex SS 1/4-20 X .62	K2	56112741	1	Kit-Stabilizer Stud
K6	3		2	Wsh-Flt SAE SS 3/8	K3	56112742	1	Kit-Solution Hose
K6	4		1	Nut-Hex Nyl Loc SS 1/4-20	K4	56112743	1	Kit-Bumper
K6	5		1	Nut-Hex Nyl Loc SS 3/8-16	K5	56112744	2	Kit-Pad Driver
K2,K6	6		4	Scr-Hex Hd Loc 3/8-16x1.25	K6	56112745	1	Kit-Deck Hardware REV2
K5,K6	7		12	Scr-Pan Phil Loc SS1/4-20X1.00	K8	9098983000	2	Kit-Driver
K6	8		1	Scr-Pan Phil Loc SS5/16-18X1.50	K9	9098984000	2	Kit-Eccentric
K3,K6	9		6	Scr, Pan Phil Thd Form 10-24 X .50	*	56112733	2	Pad Maroon Spp14
K4,K6	10		6	Scr, Flt Phil Thd Form 10-24x.50	*	56112734	2	Pad Micro Fiber-14 In
K2,K6	11		4	Wsh, Flt .406 X 1.500 X .125	*	56112746	2	Velcro 2 Sided 14
K3	12		4	Clamp-P	*	56112708	2	Brush Nylon REV-14
	13	56112700	1	Rev Deck	*	56390007	2	Kit-Brush Screw (includes 3 brush screws)
	14	56601815	2	Motor Plate				
K5	15		2	Pad Driver Assy				
	[]	56112751	2	Kit-Pad Driver Hook 14	[] = Not Shown			
	16	56112776	1	Bracket-Linkage	* = Optional, Not Included			
	17	56112707	2	Bushing-Nylon				
	18	56112723	1	Decal-Rev Embossed				
K4	19		1	Bumper				
K2	20		4	Sleeve				
	[21]	56112726	2	Jumper				
	22	56112735	1	Wheel				
	23	56112737	2	Bushing				
K3	24		1	Hose PVC				
K3	25		1	Barb, Coupler 1/2 X 3/4				
K3	26		2	Hose PVC				
	27		2	Shield Splash				
K8	28		2	Gasket Driver				
K3	29		1	Tee, Barb				
K3	30		2	Clamp-P				
K3	31		1	Tie, Cable				
	32	56900041	8	Plug, Cap				
K6	33		1	Screw 3/8-16 X 6.00				
	34	56002851		Nut, Hex Nyl Loc-Thin SS 5/16-18				
	35	56401783		Leveler				
	36	722030	1	Clamp, Hose				
K6	37		2	Rivet, 0.156 Dia X 1/2				
K6	38		8	Scr-Flt Phil Loc SS 1/4-20x.75				
K1	39		8	Isolator-40 Duro 1/4-20				
	40	56390002	2	Weight Counter				
K9	41		2	Eccentric				
	42	56390027	2	Driver Motor				
	43	56112749	2	Motor, 24VDC (M3 / M4)				
	[]	56413628	2	Brush and Spring Kit Motor				
	[]	40645A	4	Connector Housing Pp75 Black				
	[]	40657A	4	Connector Contact				
	44	30412A	1	Hose, Solution				
	45	50736A	2	Bearing				
	46	53571A	1	Clamp, Hose				
K8	47		2	Retainer, Bearing				
K1,K6	48		16	Nut, Serrated Flange				
K6,K8	49		12	Scr-Pan Phil Loc SS 1/4-20X.50				
	50			Intentionally Omitted				
	51	56420160	2	Bearing Flange E00201				
	52	56009265	1	Wsh Wave .531 X .781 X .013				
	53	56112753	1	Trim				
	54	56003221	4	Scr-Hex Loc SS 1/4-20 X .75				

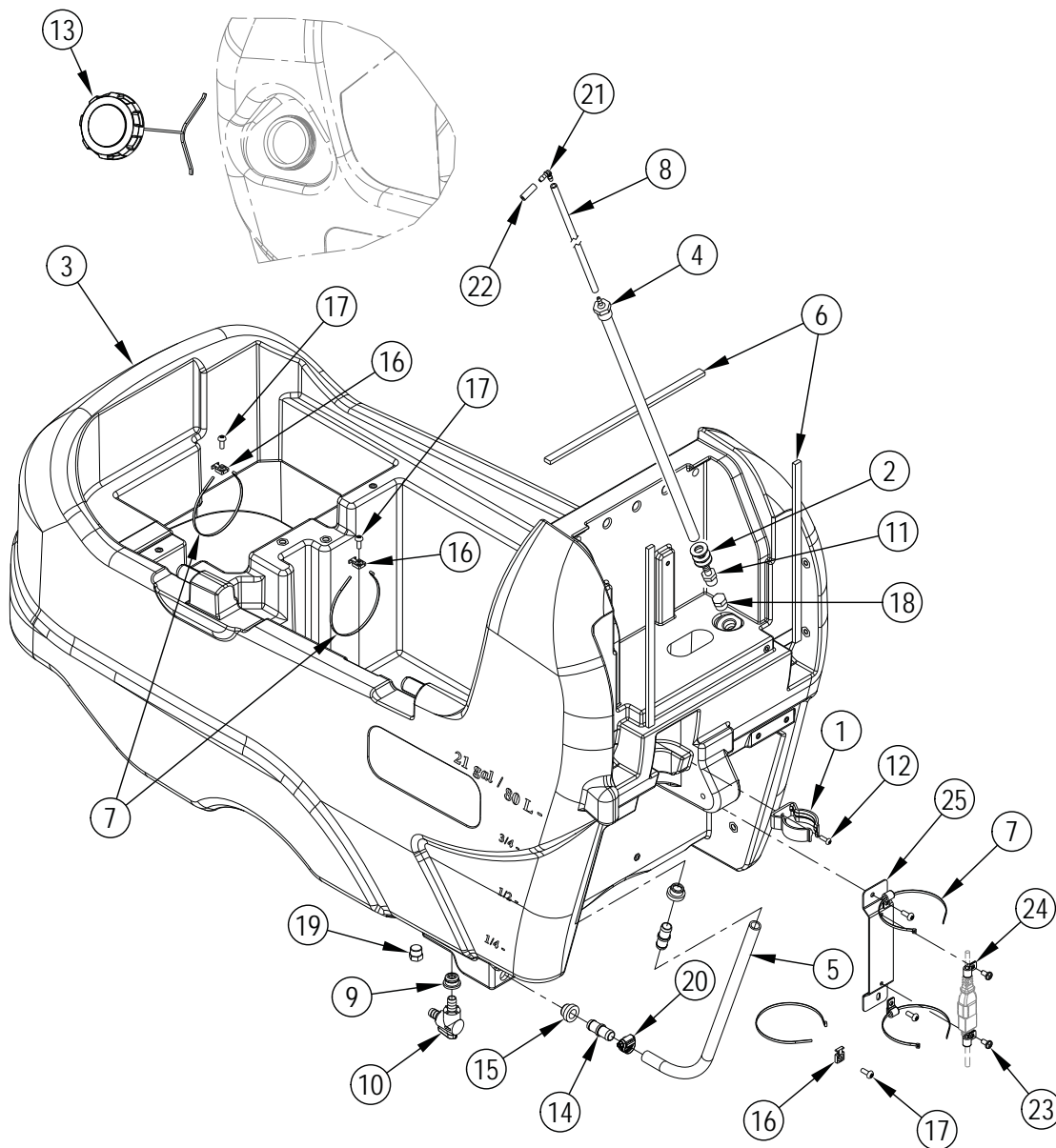

SOLUTION SYSTEM

Item	Ref. No.	Qty	Description	Item	Ref. No.	Qty	Description
1	L08812967	1	Clamp, Hose D.50	13	56601599	1	Cap-Raw With Tether
2	56002918	3	Wsh, Fit SAE SS 1/2 (SC750, SC800)	14	56112775	2	Connector-Straight
3	56112105	1	Solution Tank (SC750, SC750 ST models)	15	31242A	2	Bushing
	56112101	1	Solution Tank (SC800, SC800 ST models)	16#	52548A	3	Tab, 1/4" Screw NOTE 2
4	56112145	1	Tube-Pressure Sensing (SC750, SC800)	17#	80208A	5	Screw, M6 X 1.00 X 10mm Pan Head NOTE 2
5	56383997	1	Hose-PVC-5/8X19	18	56305547	1	Plug, 1/2 Hex Pipe (SC750 ST, SC800 ST)
6	56419275	3	Gasket, .25 X .50	19	56261421	1	Plug-Hex Pipe (SC800, SC800 ST models)
7#	56478523	5	Tie, Cable NOTE 2	20#	166USP	1	Hose Clamp 3/8-7/8
8	56112551	1	Hose (SC750, SC800) / NOTE 1	21	56112552	1	Elbow 3/16 X 3/16 Poly NOTE 1
9	9095286000	1	Gasket	22	56112550	1	Hose NOTE 1
10	9097028000	1	Ball Valve 90°	23	56009062	2	Scr, Pan Phil Thd Form 1/4-20 x .50
11	56054691	1	Adaptor-Barb Male (SC750, SC800)	24	56323260	4	Clamp, Hose Support
12	964004	1	Screw M5-.8 X 16mm Pn St Ph	25	56383383	1	Power Cord Bracket

= Revised or new since last update

NOTE 1: Hose 56601273 is obsolete. To replace 56601273 please order Solution Level Kit 56112554.

NOTE 2:# The quantity of these parts increased by (1 each) and were implemented in production as of November 6th 2014.

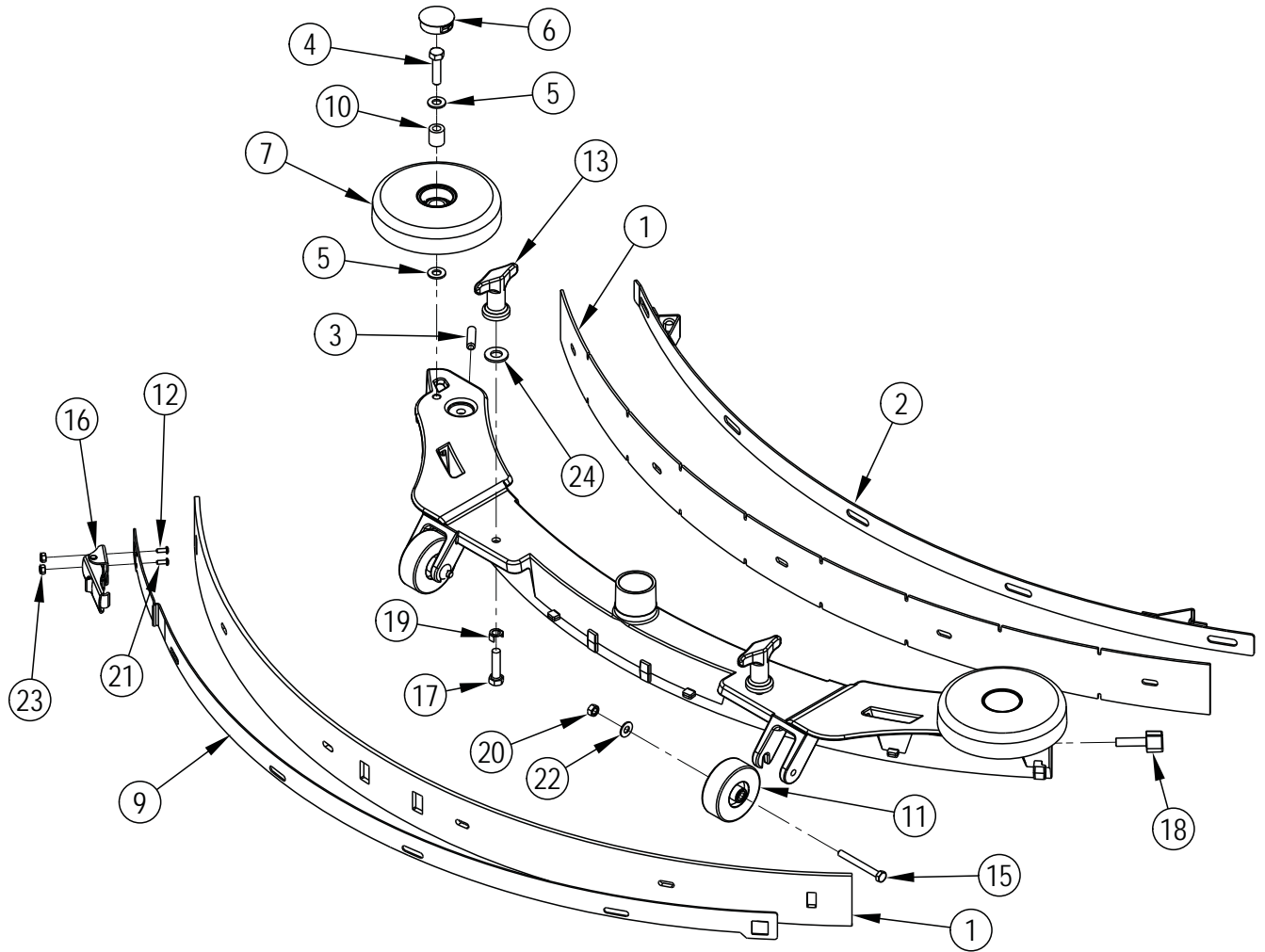

SQUEEGEE ASSY

Item	Ref. No.	Qty	Description	Item	Ref. No.	Qty	Description
	56112313	1	Squeegee Assy (26" & 28" models)	17	56002884	2	Scr Hex SS 5/16-18 X 1.25
	56112315	1	Squeegee Assy (32" & 34" models)	18	54647A	1	Knob, M8 X 30
1	56112330	1	Blade Kit-Squeegee Gum (26" & 28" models) NOTE 1	19	60564A	2	Shim, Squeegee Knob
	56112333	1	Blade Kit-Squeegee Gum (32" & 34" models) NOTE 1	20	80199A	2	Nut, M6 -1.00 Nyloc S.S.
2	60466A	1	Strap-Squeegee Front (26" & 28" models)	21	56002909	2	Scr-Pan Phil SS 6-32 x .38
	60546A	1	Strap-Squeegee Front (32" & 34" models)	22	87026A	2	Washer, 1/4 Flat S.S.
3	88632A	1	Scr, Soc Setscrew, Set M8-1.25 X 30mm	23	56002907	2	Nut-Hex Nyl Loc SS 6-32
4	56002884	2	Scr- Hex SS 5/16-18 X 1.25	24	87607A	2	Washer Flt 1.25X.52X.06 Nylon
5	56002938	4	Wsh, Flt SAE SS 5/16				Squeegee Blade Kits for 56112313
6	56111444	2	Button Plug-1.25		56112330	1	Blade Kit-Squeegee Gum NOTE 1
7	56112108	2	Wheel	*	56112331	1	Blade Kit-Squeegee Red Gum NOTE 1
9	56112213	1	Strap-Squeegee Rear (26" & 28" models)	*	56112332	1	Blade Kit-Squeegee PU NOTE 1
	56112214	1	Strap-Squeegee Rear (32" & 34" models)				Squeegee Blade Kits for 56112315
10	56601499	2	Bushing, Nylon		56112333	1	Blade Kit-Squeegee Gum NOTE 1
11	9099133000	2	Wheel 60x20 With Bushing	*	56112334	1	Blade Kit-Squeegee Red Gum NOTE 1
12	56112300	1	Rear Latch Strap	*	56112335	1	Blade Kit-Squeegee PU NOTE 1
13	56370711	2	Nut Thumb				
15	88629A	2	Screw, Hex Thd To Hd M6-1x55				
16	L08602664	1	Latch Squeegee				

* = Optional, Not Included

NOTE 1: All squeegee blade kits include both front and rear squeegee blades.

SQUEEGEE SYSTEM

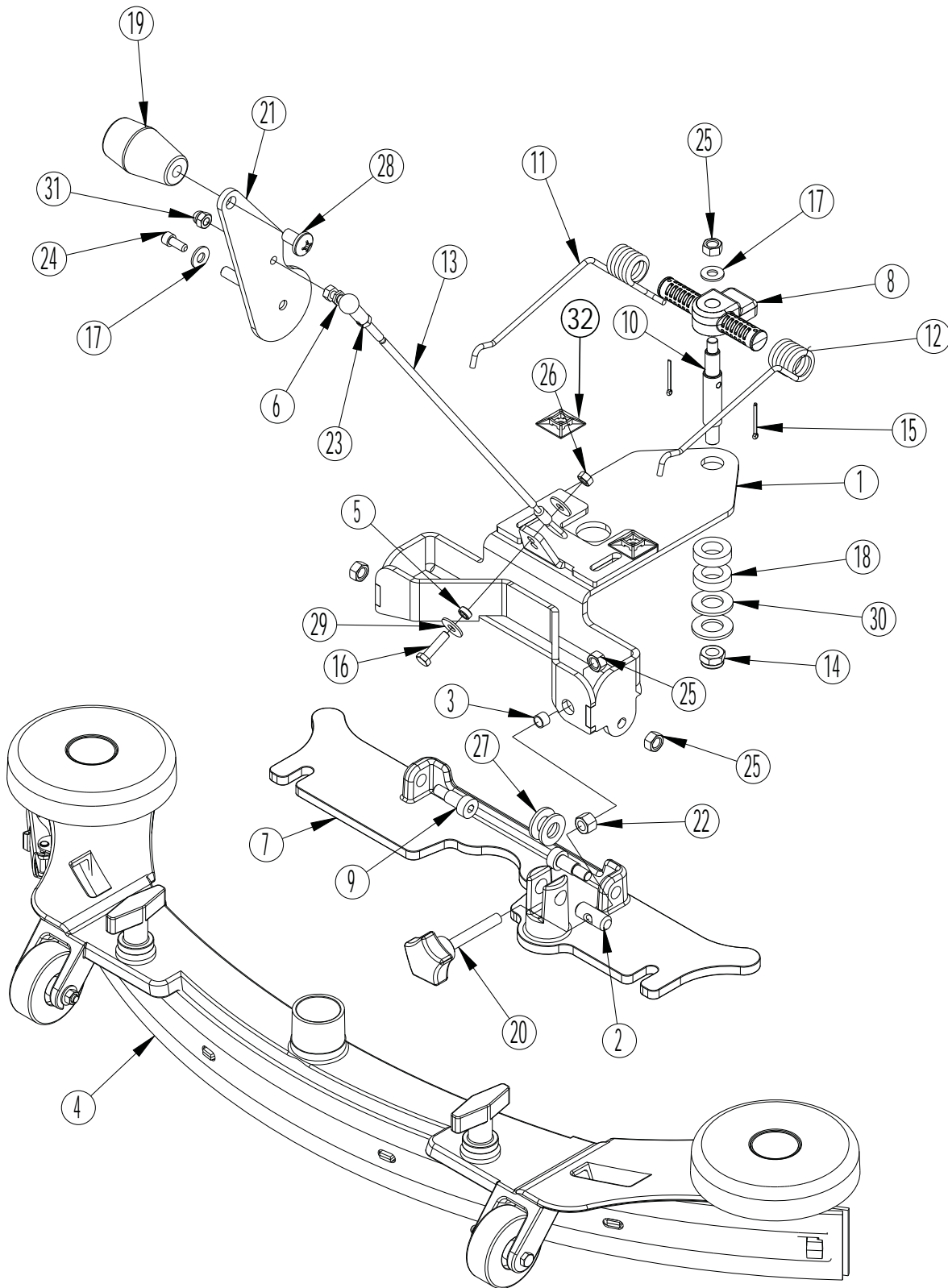

SQUEEGEE SYSTEM

Item	Ref. No.	Qty	Description
1	56112770	1	Plate-Squeegee Weldt
2	L08601509	1	Pivot Support
3	L08602422	1	Spacer
4	56112313	1	Squeegee Assy (26" & 28" models / Includes Gum Rubber Blades)
	56112315	1	Squeegee Assy (32" & 34" models / Includes Gum Rubber Blades)
5	1451252000	1	Spacer 6.5x10x4.5
6	1458479000	1	Joint, Ball M6
7#	9096045000	1	Squeegee Support TSB-FC-2014-031
8	9096052000	1	Squeegee Spring Support
9	9096495000	2	Shoulder Screw M10 X 16
10	9096497000	1	Shaft
11	9096537000	1	Push Squeegee Spring
12	9096538000	1	Push Squeegee Spring
13	9097366000	1	Cable, Squeegee Lifting
14	80223A	1	Nut, M10-1.5 Nylock
15	925044	2	Pin, Cotter-.094 X 1.00
16	56003430	1	Scr Hex SS M6-1.00X25MM
17	980651	2	Washer, 5/16 Flat
18	38708A	2	Spacer
19	52557A	1	Knob, Lift
20	54699A	1	Knob, M8 X 55
21	61952A	1	Lever, Squeegee Lift
22	80163A	1	Nut M8-1.25 Hex
23	80171A	1	Nut, M6 Hex
24	80179A	1	Screw, M6 X 15
25	80198A	4	Nut, M8 -1.25 Nylock S.S.
26	80199A	1	Nut, M6 -1.00 Nylock S.S.
27	80424A	2	Washer Flat
28	85389A	1	Screw, 3/8-16 X 5/8
29	87007A	2	Washer Control Shaft
30	87613A	2	Washer Flat1.22 X .64 X .10 Nylon
31	88640A	1	Nut, M6-1 Acorn
32	9096635000	2	Self-Adhesive Sideburns

= Revised or new since last update

LADDER DIAGRAM-SC750, SC800 BEFORE SN4000068715

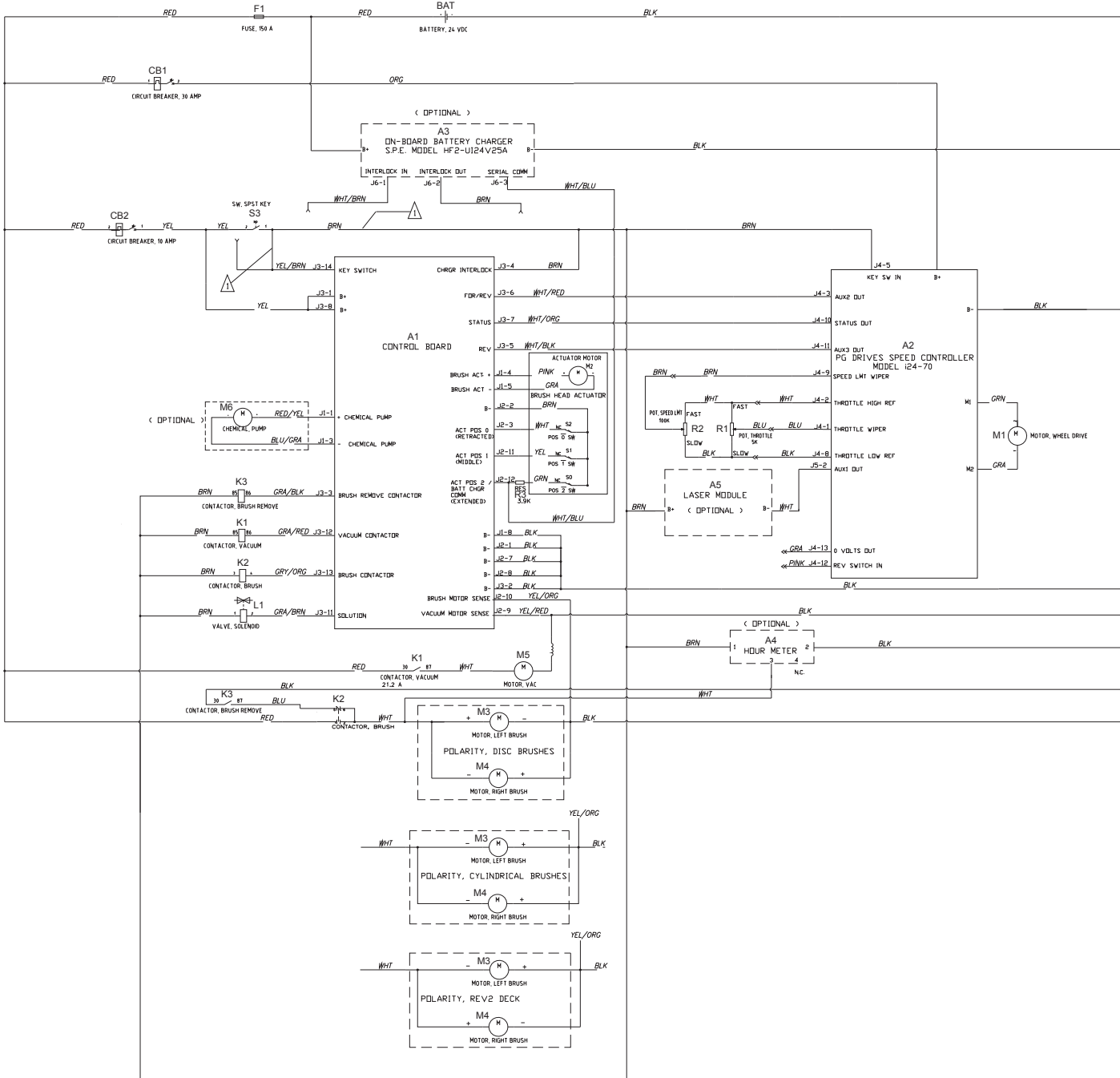

LADDER DIAGRAM-SC750, SC800 BEFORE SN4000068715

Item	Ref. No.	Qty	Description
A1	56112351	1	Kit AXP Control Board
A2	56112187	1	Speed Controller 70A 24V
A3	56383869	1	Kit-OBC SC750 (Optional)
A4	56393718	1	Hour Meter (Optional)
A5	56112136	1	Laser Module (Optional)
BAT			Battery-24VDC
F1	56412089	1	Fuse, 150 Amp
CB1	56315256	1	Circuit Breaker-30 Amp
CB2	56507644	1	Circuit Breaker-10 Amp
K1	41075A	1	Contactora-Vacuum
K2	56397088	1	Contactora-Brush
K3	41075A	1	Contactora-Brush Remove
L1	56112147	1	Solenoid-Solution
M1	56382670	1	Kit Transaxle Motor
M2	40280A	1	Motor-Actuator
M3	56112240	1	Motor Gearbox Assy (Disk)
	56112111	1	Motor-24 VDC 3/4HP (Cylindrical)
	56112749	1	Motor, 24VDC (REV)
M4	56112240	1	Motor Gearbox Assy (Disk)
	56112111	1	Motor-24 VDC 3/4HP (Cylindrical)
	56112749	1	Motor, 24VDC (REV)
M5	56112239	1	Motor-Vacuum
M6	56315241	1	Pump-Chemical (Optional)
R1	56397029	1	Potentiometer, 5K Ohm, Throttle
R2	56396197	1	Potentiometer-Speed Limit
R3		1	Part of Main Wiring Harness
S0		1	Part of M2
S1		1	Part of M2
S2		1	Part of M2
S3	56303553	1	Switch, Key

LADDER DIAGRAM-SC750, SC800 AFTER SN4000068715

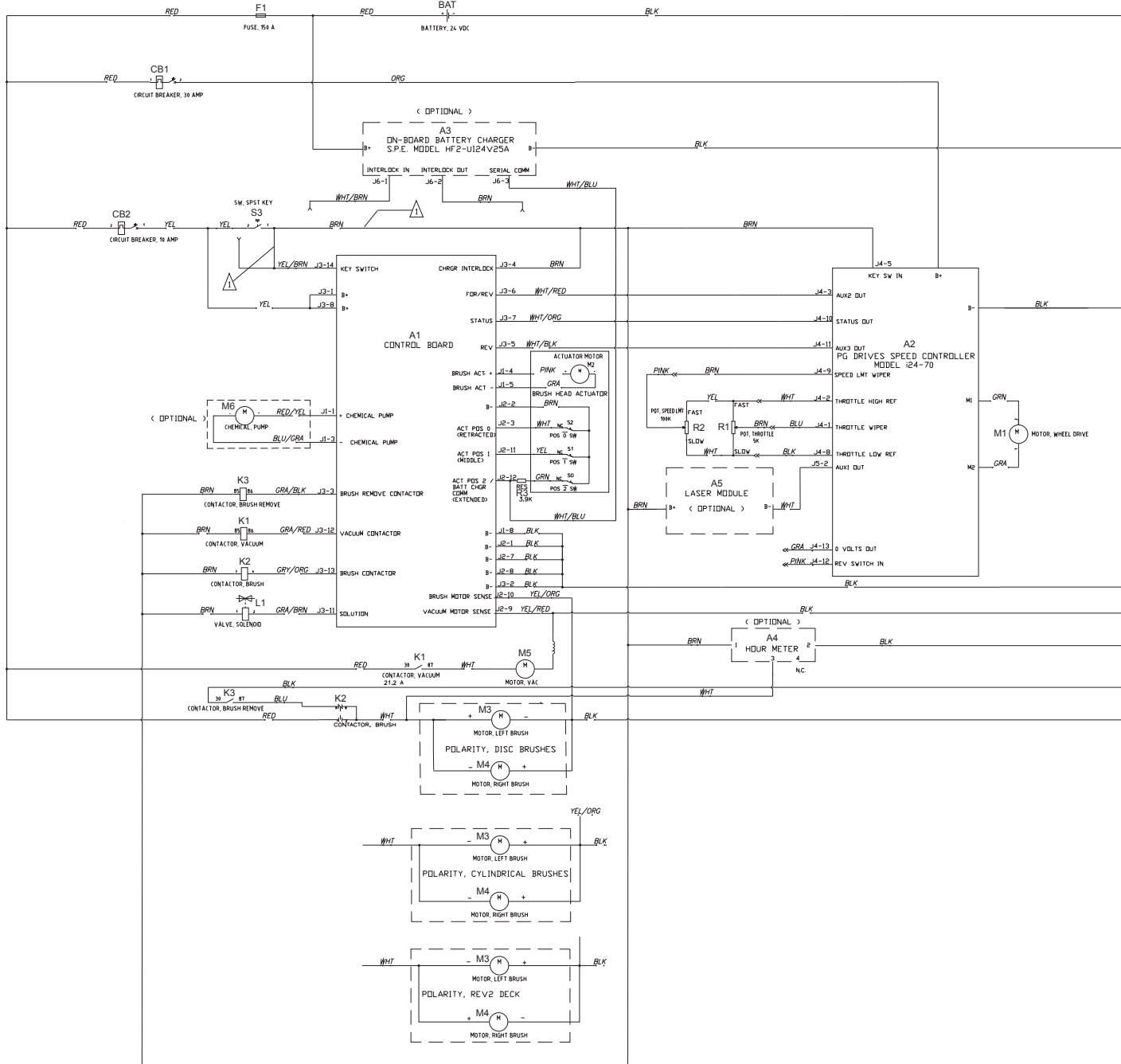

LADDER DIAGRAM-SC750, SC800 AFTER SN4000068715

Item	Ref. No.	Qty	Description
A1	56112351	1	Kit AXP Control Board
A2	56112187	1	Speed Controller 70A 24V
A3	56383869	1	Kit-OBC SC750 (Optional)
A4	56393718	1	Hour Meter (Optional)
A5	56112136	1	Laser Module (Optional)
BAT			Battery-24VDC
F1	56412089	1	Fuse, 150 Amp
CB1	56315256	1	Circuit Breaker-30 Amp
CB2	56507644	1	Circuit Breaker-10 Amp
K1	41075A	1	Contactora-Vacuum
K2	56397088	1	Contactora-Brush
K3	41075A	1	Contactora-Brush Remove
L1	56112147	1	Solenoid-Solution
M1	56382670	1	Kit Transaxle Motor
M2	40280A	1	Motor-Actuator
M3	56112240	1	Motor Gearbox Assy (Disk)
	56112111	1	Motor-24 VDC 3/4HP (Cylindrical)
	56112749	1	Motor, 24VDC (REV)
M4	56112240	1	Motor Gearbox Assy (Disk)
	56112111	1	Motor-24 VDC 3/4HP (Cylindrical)
	56112749	1	Motor, 24VDC (REV)
M5	56112239	1	Motor-Vacuum
M6	56315241	1	Pump-Chemical (Optional)
R1	56397029	1	Potentiometer, 5K Ohm, Throttle
R2	56396197	1	Potentiometer-Speed Limit
R3		1	Part of Main Wiring Harness
S0		1	Part of M2
S1		1	Part of M2
S2		1	Part of M2
S3	56303553	1	Switch, Key

LADDER DIAGRAM-SC750, SC800 AFTER JUNE 2014

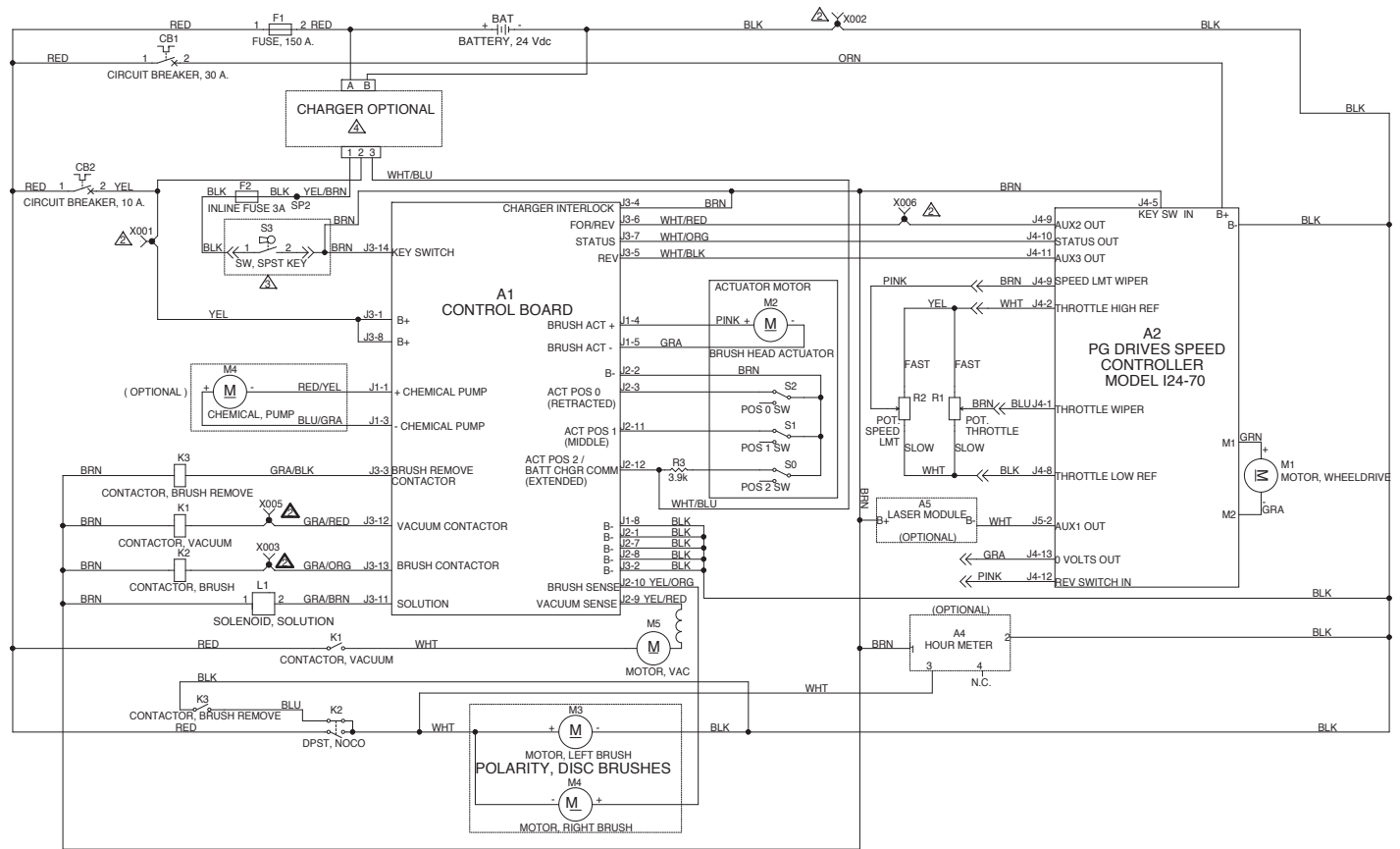

NOTES:
 △ CONNECTORS WITH X00X ARE TRACKCLEAN CONNECTIONS.
 △ IF TRACKCLEAN OPTION IS INSTALLED, REFER TO TRACKCLEAN CONNECTIONS AND EITHER DETAIL A OR B.
 △ REFER TO CHARGER CONNECTIONS FOR ONBOARD CHARGER CONFIGURATIONS.

△ CHARGER OPTIONS

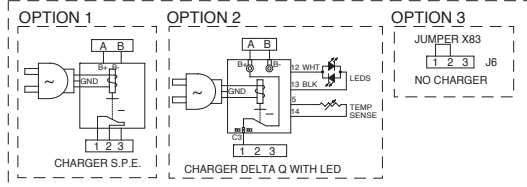

△ TRACKCLEAN CONNECTIONS (OPTIONAL)

- X001 - B+ (RED)
- X002 - B- (BLUE)
- X003 - SCRUB (WHITE)
- X004 - KEY SWITCH (BROWN)
- X005 - VACUUM (GRAY)
- X006 - DRIVE (PINK)
- X007
- X008
- X009 } SEE DETAIL DIAGRAMS

DETAIL A - WITH ACCESS CONTROL

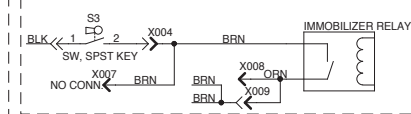

DETAIL B - WITHOUT ACCESS CONTROL

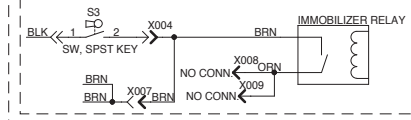

LADDER DIAGRAM-SC750, SC800 AFTER JUNE 2014

Item	Ref. No.	Qty	Description
A1	56112351	1	Kit AXP Control Board
A2	56112187	1	Speed Controller 70A 24V
A3	56383869	1	Kit-OBC SC750 (Optional)
A4	56393718	1	Hour Meter (Optional)
A5	56112136	1	Laser Module (Optional)
BAT			Battery-24VDC
F1	56412089	1	Fuse, 150 Amp
CB1	56315256	1	Circuit Breaker-30 Amp
CB2	56507644	1	Circuit Breaker-10 Amp
K1	41075A	1	Contactora-Vacuum
K2	56397088	1	Contactora-Brush
K3	41075A	1	Contactora-Brush Remove
L1	56112147	1	Solenoid-Solution
M1	56382670	1	Kit Transaxle Motor
M2	40280A	1	Motor-Actuator
M3	56112240	1	Motor Gearbox Assy (Disk)
	56112111	1	Motor-24 VDC 3/4HP (Cylindrical)
	56112749	1	Motor, 24VDC (REV)
M4	56112240	1	Motor Gearbox Assy (Disk)
	56112111	1	Motor-24 VDC 3/4HP (Cylindrical)
	56112749	1	Motor, 24VDC (REV)
M5	56112239	1	Motor-Vacuum
M6	56315241	1	Pump-Chemical (Optional)
R1	56397029	1	Potentiometer, 5K Ohm, Throttle
R2	56396197	1	Potentiometer-Speed Limit
R3		1	Part of Main Wiring Harness
S0		1	Part of M2
S1		1	Part of M2
S2		1	Part of M2
S3	56303553	1	Switch, Key

LADDER DIAGRAM-SC750 ST, SC800 ST BEFORE SN4000068715

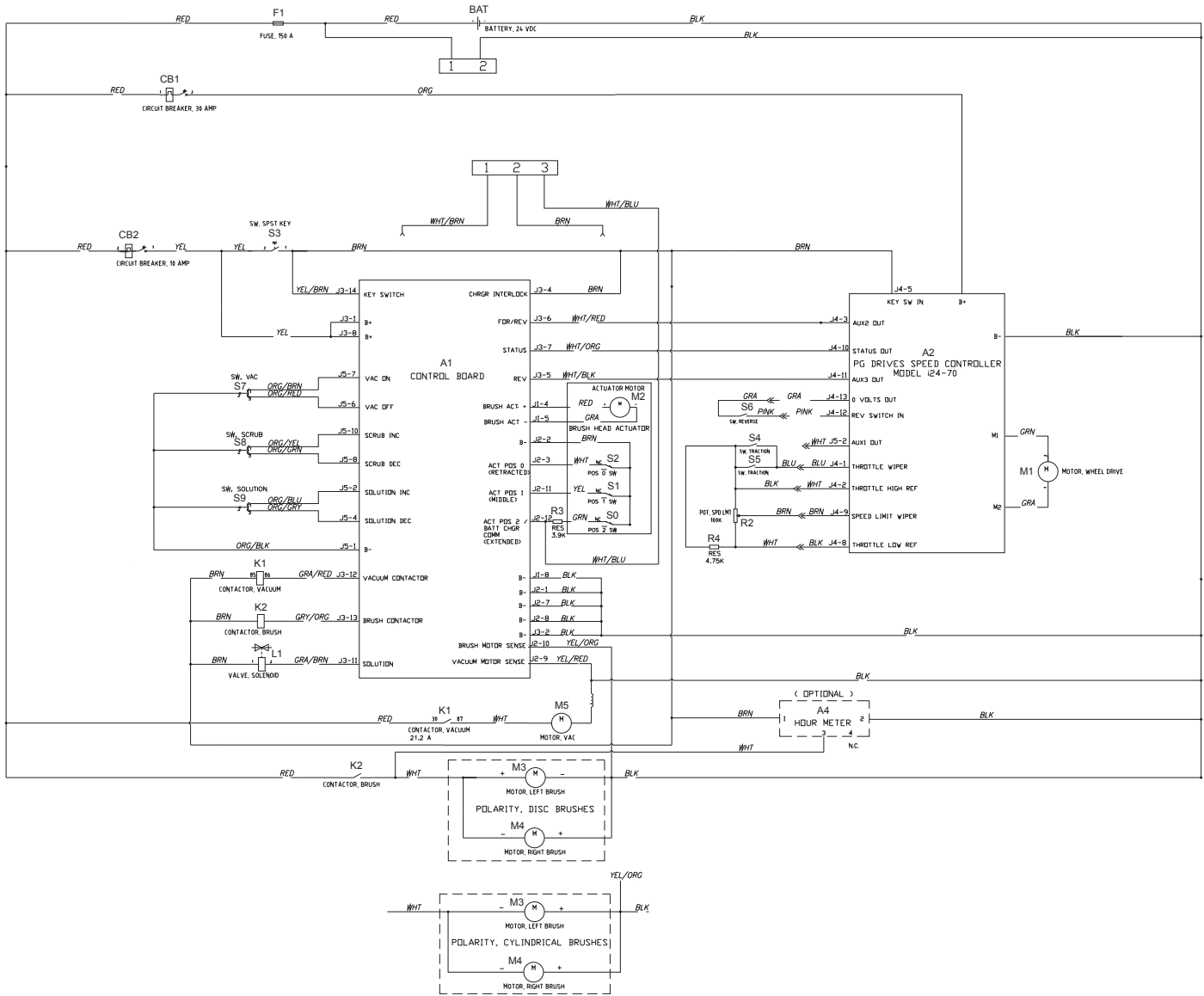

LADDER DIAGRAM-SC750 ST, SC800 ST BEFORE SN4000068715

Item	Ref. No.	Qty	Description
A1	56112352	1	Kit ST Control Board
A2	56112241	1	Speed Controller 70a 24v
A4	56393718	1	Hour Meter (Optional)
BAT			Battery-24VDC
F1	56412089	1	Fuse, 150 Amp
CB1	56315256	1	Circuit Breaker-30 Amp
CB2	56507644	1	Circuit Breaker-10 Amp
K1	41075A	1	Contactora-Vacuum
K2	56412179	1	Contactora 24 VDC (Brush)
L1	56112147	1	Solenoid-Solution
M1	56382670	1	Kit Transaxle Motor
M2	40280A	1	Motor-Actuator
M3	56112240	1	Motor Gearbox Assy (Disk)
	56112111	1	Motor-24 VDC 3/4HP (Cylindrical)
M4	56112240	1	Motor Gearbox Assy (Disk)
	56112111	1	Motor-24 VDC 3/4HP (Cylindrical)
M5	56112239	1	Motor-Vacuum
R2	56315929	1	Potentiometer-Speed Limit
R3		1	Part of Main Wiring Harness
R4		1	Resistor-4.75K
S0		1	Part of M2
S1		1	Part of M2
S2		1	Part of M2
S3	56303553	1	Switch, Key
S4	56315935	1	Switch-Traction
S5	56315935	1	Switch-Traction
S6	56315945	1	Switch-Reverse
S7	56112190	1	Switch-Vacuum
S8	56112190	1	Switch-Scrub
S9	56112190	1	Switch-Solution

LADDER DIAGRAM-SC750 ST, SC800 ST AFTER SN4000068715

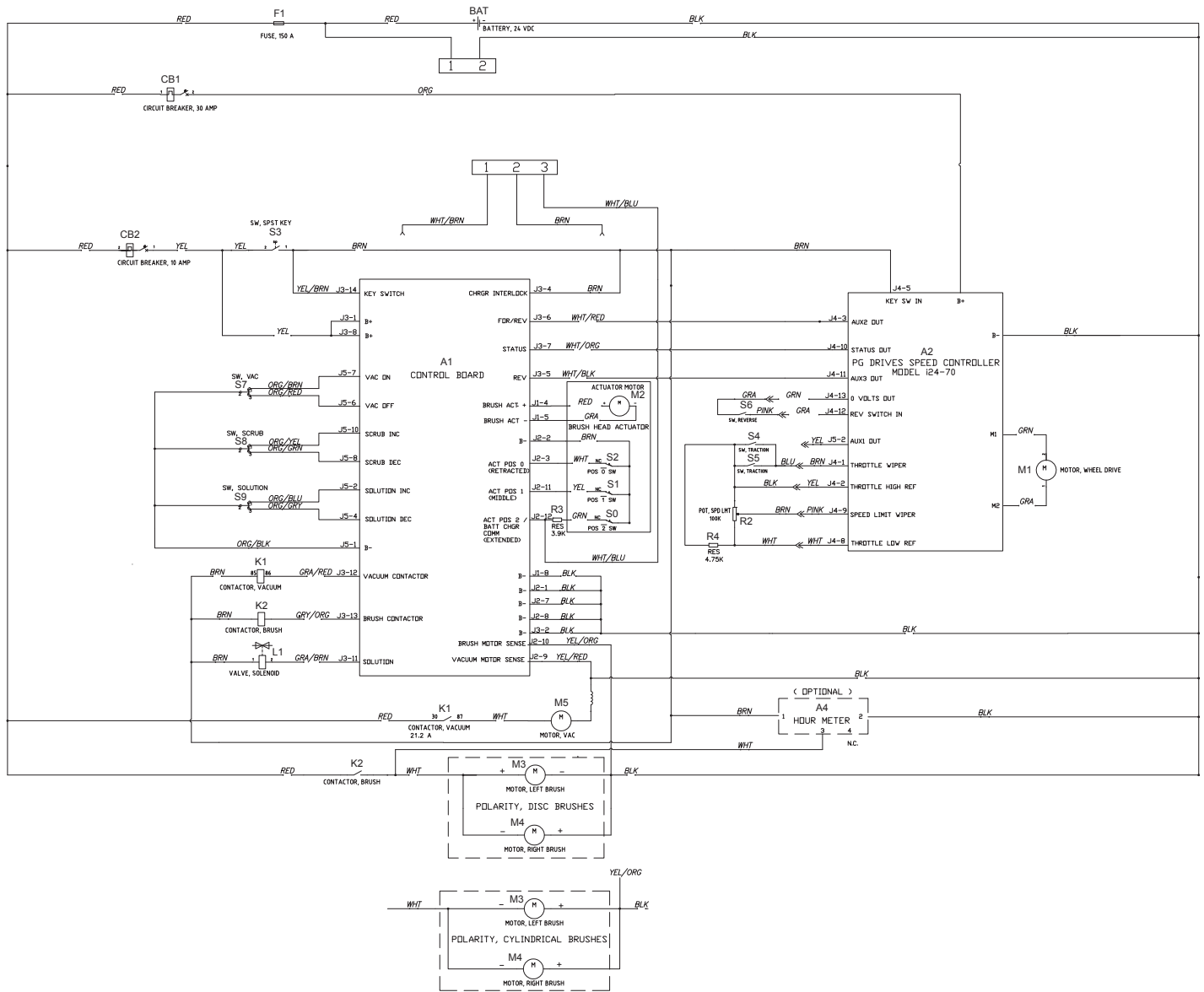

LADDER DIAGRAM-SC750 ST, SC800 ST AFTER SN4000068715

Item	Ref. No.	Qty	Description
A1	56112352	1	Kit ST Control Board
A2	56112241	1	Speed Controller 70a 24v
A4	56393718	1	Hour Meter (Optional)
BAT			Battery-24VDC
F1	56412089	1	Fuse, 150 Amp
CB1	56315256	1	Circuit Breaker-30 Amp
CB2	56507644	1	Circuit Breaker-10 Amp
K1	41075A	1	Contactora-Vacuum
K2	56412179	1	Contactora 24 VDC (Brush)
L1	56112147	1	Solenoid-Solution
M1	56382670	1	Kit Transaxle Motor
M2	40280A	1	Motor-Actuator
M3	56112240	1	Motor Gearbox Assy (Disk)
	56112111	1	Motor-24 VDC 3/4HP (Cylindrical)
M4	56112240	1	Motor Gearbox Assy (Disk)
	56112111	1	Motor-24 VDC 3/4HP (Cylindrical)
M5	56112239	1	Motor-Vacuum
R2	56315929	1	Potentiometer-Speed Limit
R3		1	Part of Main Wiring Harness
R4		1	Resistor-4.75K
S0		1	Part of M2
S1		1	Part of M2
S2		1	Part of M2
S3	56303553	1	Switch, Key
S4	56315935	1	Switch-Traction
S5	56315935	1	Switch-Traction
S6	56315945	1	Switch-Reverse
S7	56112190	1	Switch-Vacuum
S8	56112190	1	Switch-Scrub
S9	56112190	1	Switch-Solution

LADDER DIAGRAM-SC750 ST, SC800 ST AFTER JUNE 2014

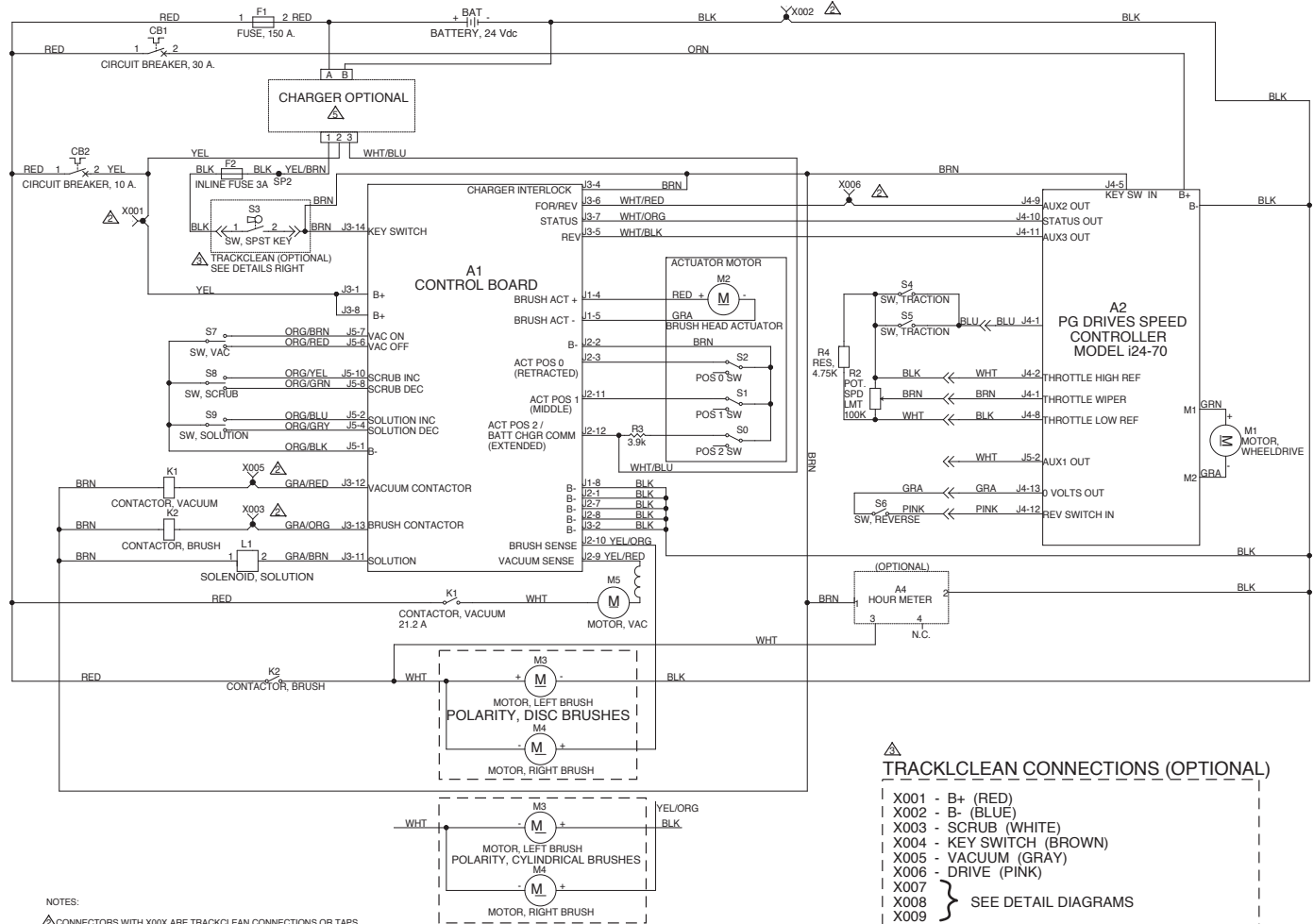

NOTES:
 ⚠️ CONNECTORS WITH X00X ARE TRACKCLEAN CONNECTIONS OR TAPS
 ⚠️ IF TRACKCLEAN OPTION IS INSTALLED, SEE DETAILS A, B, C, OR D.
 ⚠️ REFER TO CHARGER CONNECTIONS FOR ONBOARD CHARGER CONFIGURATIONS.

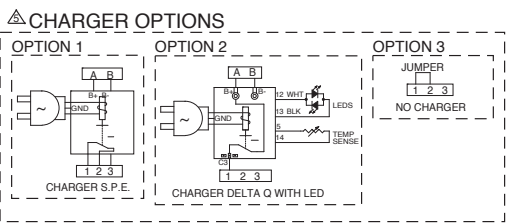

TRACKCLEAN CONNECTIONS (OPTIONAL)

- X001 - B+ (RED)
- X002 - B- (BLUE)
- X003 - SCRUB (WHITE)
- X004 - KEY SWITCH (BROWN)
- X005 - VACUUM (GRAY)
- X006 - DRIVE (PINK)
- X007 } SEE DETAIL DIAGRAMS
- X008 }
- X009 }

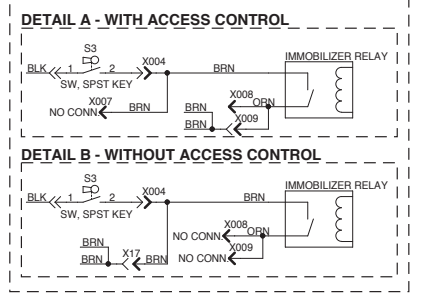

LADDER DIAGRAM-SC750 ST, SC800 ST AFTER JUNE 2014

Item	Ref. No.	Qty	Description
A1	56112352	1	Kit ST Control Board
A2	56112241	1	Speed Controller 70a 24v
A4	56393718	1	Hour Meter (Optional)
BAT			Battery-24VDC
F1	56412089	1	Fuse, 150 Amp
CB1	56315256	1	Circuit Breaker-30 Amp
CB2	56507644	1	Circuit Breaker-10 Amp
K1	41075A	1	Contactora-Vacuum
K2	56412179	1	Contactora 24 VDC (Brush)
L1	56112147	1	Solenoid-Solution
M1	56382670	1	Kit Transaxle Motor
M2	40280A	1	Motor-Actuator
M3	56112240	1	Motor Gearbox Assy (Disk)
M3	56112111	1	Motor-24 VDC 3/4HP (Cylindrical)
M4	56112240	1	Motor Gearbox Assy (Disk)
M4	56112111	1	Motor-24 VDC 3/4HP (Cylindrical)
M5	56112239	1	Motor-Vacuum
R2	56315929	1	Potentiometer-Speed Limit
R3		1	Part of Main Wiring Harness
R4		1	Resistor-4.75K
S0		1	Part of M2
S1		1	Part of M2
S2		1	Part of M2
S3	56303553	1	Switch, Key
S4	56315935	1	Switch-Traction
S5	56315935	1	Switch-Traction
S6	56315945	1	Switch-Reverse
S7	56112190	1	Switch-Vacuum
S8	56112190	1	Switch-Scrub
S9	56112190	1	Switch-Solution

OPTIONAL KITS & ACCESSORIES

Item	Ref. No.	Qty	Description
*	56383869	1	Kits
*	56112141	1	Kit-OBC SC750 NOTE 2
*	56601527	1	Kit-VacuumWand With Tote Bag
*	56302198	1	Kit-Battery Watering
*	56112138	1	Kit-Hour Meter
*	56112138	1	Kit-Laser (SC750, SC800 only)
*	56112140	1	Kit-Wet Floor Sign Holder
*	56112312	1	Kit-Mop Holder
			Squeegee Blade Kits for 56112313 (See Squeegee Blade Selector Guide)
	56112330	1	Blade Kit-Squeegee Gum NOTE 1
*	56112331	1	Blade Kit-Squeegee Red Gum NOTE 1
*	56112332	1	Blade Kit-Squeegee PU NOTE 1
			Squeegee Blade Kits for 56112315 (See Squeegee Blade Selector Guide)
	56112333	1	Blade Kit-Squeegee Gum NOTE 1
*	56112334	1	Blade Kit-Squeegee Red Gum NOTE 1
*	56112335	1	Blade Kit-Squeegee PU NOTE 1
			Accessories
*	56112222	1	Utility Caddy
*	56112255	1	Programmer With Cable
*	56397453	6	Indicator-Battery Level (1 per battery)
*#	56384137	1	Idler W/O-Ring Kit
*	56044438	1	Literature Pack (manufactured before July 2014)
*	56044683	1	Literature Pack (manufactured after June 2014)
			26" Disk Scrub Brushes (See Brush Selector Guide)
*	56505760	2	Short Trim Pad Holder
*	56505195	2	Pad Retainer for 56505750
*	56505765	2	ProLite
*	56505764	2	Prolene
*	56505766	2	Union Mix
*	56505763	2	AgLite Grit 500
*	56505767	2	MidGrit 240
*	56505768	2	MidLite Grit 180
*	56505762	2	Dyna Grit 80
*	56505761	2	Magna Grit 46
			28" Cylindrical Scrub Brushes (See Brush Selector Guide)
*			56412191 2 Soft Nylon
*			56412192 2 Hard Nylon
*			56412046 2 Prolene
*			56412193 2 MidLite Grit 180
*			56412194 2 Dyna Grit 80
*			56412195 2 Magna Grit 46
			32" Cylindrical Scrub Brushes (See Brush Selector Guide)
*			56407473 2 Soft Nylon
*			56407474 2 Hard Nylon
*			56407475 2 Prolene
*			56407476 2 MidLite Grit 180
*			56407477 2 Dyna Grit 80
*			56407478 2 Magna Grit 46
			28" Disk Scrub Brushes (See Brush Selector Guide)
*	56505800	2	Short Trim Pad Holder
*	56505195	2	Pad Retainer for 56505750
*	56505805	2	ProLite
*	56505804	2	Prolene
*	56505806	2	Union Mix
*	56505803	2	AgLite Grit 500
*	56505807	2	MidGrit 240
*	56505808	2	MidLite Grit 180
*	56505802	2	Dyna Grit 80
*	56505801	2	Magna Grit 46
			34" Disk Scrub Brushes (See Brush Selector Guide)
*	56505780	2	Short Trim Pad Holder
*	56505195	2	Pad Retainer for 56505750
*	56505785	2	ProLite
*	56505784	2	Prolene
*	56505786	2	Union Mix
*	56505783	2	AgLite Grit 500
*	56505787	2	MidGrit 240
*	56505788	2	MidLite Grit 180
*	56505782	2	Dyna Grit 80
*	56505781	2	Magna Grit 46

* = Optional, Not Included

= Revised or new since last update

NOTE 1: All squeegee blade kits include both front and rear squeegee blades.**NOTE 2:** Onboard Charger Kit 56112547 is no longer available and has been replaced by 56383869.

RECOMMENDED SPARE PARTS

Item	Ref. No.	Qty	Description	Item	Ref. No.	Qty	Description
			WEAR PARTS				EXTRAORDINARY MAINTENANCE
	40628A	4	Carbon Brush (for 50981A)		56112521	1	Gimbal Assembly
	56382640	1	Carbon Brush Set of 2 (for 56112239)		56366455	1	Plate, Stop
	56112242	2	Carbon Brush (for 56112240)		56109653	1	Spring Retainer
	56412257	1	Brush Cap Assy (for 56112111)		56601056	1	Spring, Brush Holder
	56407391	2	Blade		56601118	1	Brush Plate
			Squeegee Blade Kits for 56112313		56112111	2	Motor-24 Vdc 3/4hp (M3 / M4)
	56112330	1	Blade Kit-Squeegee Gum NOTE 1		56112523	1	Linkage Bracket
	56112331	1	Blade Kit-Squeegee Red Gum NOTE 1		56315321	2	Belt, Auto Tension
	56112332	1	Blade Kit-Squeegee PU NOTE 1		56315408	2	Drive End Assy
			Squeegee Blade Kits for 56112315		56315445	2	Cover, Belt
	56112333	1	Blade Kit-Squeegee Gum NOTE 1		56315448	2	Idler End Assy
	56112334	1	Blade Kit-Squeegee Red Gum NOTE 1		56396254	2	Knob (for 56315448)
	56112335	1	Blade Kit-Squeegee PU NOTE 1		56412459	2	Wheel
			ORDINARY MAINTENANCE		30412A	1	Hose-Solution
	56112308	1	Caster, Rear		L08812967	1	Clamp, Hose D.50
			EXTRAORDINARY MAINTENANCE		56112145	1	Tube-Pressure Sensing
	56112109	2	Tire		56383997	1	Hose-PVC-5/8X19
	56112147	1	Solenoid Valve Assy (L1)		56419275	3	Gasket, .25 X .50
	56112543	1	Transaxle		56112554	1	Solution Level Kit
	56380158	2	Flange Kit (for 56112543)		9097028000	1	Ball Valve 90°
	56382670	1	Kit Transaxle Motor (for 56112543) (M1)		9097290000	1	Filling Hose
	40280A	1	Actuator (M2)		56112345	1	Fill Hose Support
	9100000362	1	Filter Water TSB-FC-2013-127		56601599	1	Cap-Raw With Tether
	9095215000	1	Filter and Seal (for 9100000362)		56112108	2	Wheel
	9097456000	1	Lever		909 6505 000	2	Wheel 90x20 With Bushing
	54689a	1	Gas Spring 500n		56370711	2	Nut Thumb
	56396197	1	Potentiometer-Speed Limit (R2)		909 6052 000	1	Squeegee Spring Support
	56397029	1	Potentiometer-5k (R1)		52557A	1	Knob, Lift
	56109716	1	Paddle-Back Cover		909 6635 000	2	Self-Adhesive Sideburns
	56315230	1	Paddle, Front Cover				
	56315280	1	Knob				
	56112351	1	Kit AXP Control Board				
	56303553	1	Switch-Key (for 56112351) (S3)				
	56303526	1	Replacement Key Set (for 56303553)				
	56112253	1	Kit-Interface Panel (Membrane Switch, Membrane Panel, Gasket)				
	56112187	1	Speed Controller 70a 24v (A2)				
	56315256	1	Circuit Breaker, 30 Amp (CB1)				
	56397088	1	Contact, 24v Spdt (K2)				
	56412089	1	Fuse, 150 Amp (F1)				
	56507644	1	Circuit Breaker, 10 Amp (CB2)				
	41075A	2	Relay, 40A (K1 / K3)				
	56112239	1	Vac Motor-24 Vdc (M5)				
	56112316	1	Suction Hose				
	909 6634 000	1	Stop Tank Cable				
	56344168	1	Filter				
	56112310	1	Drain Hose-Recovery				
	56112303	1	Kit-Float Ball Cage				
	56109651	1	Brush Plate Assy - CCW				
	56109652	1	Brush Plate Assy - CW				
	56112523	1	Linkage Bracket				
	56112240	2	Motor Gearbox Assy (M3 / M4)				
	56112257	1	Brush Skirt Assy-26D Left (26" models)				
	56112259	1	Brush Skirt Assy-28D Left (28" models)				
	56112261	1	Brush Skirt Assy-34D Left (34" models)				
	56112258	1	Brush Skirt Assy-26D Right (26" models)				
	56112260	1	Brush Skirt Assy-28D Right (28" models)				
	56112262	1	Brush Skirt Assy-34D Right (34" models)				
	56112305	1	Kit-Bristle Skirt 26 (26" models / Includes two skirts and mounting hardware)				
	56112306	1	Kit-Bristle Skirt 28 (28" models / Includes two skirts and mounting hardware)				
	56112307	1	Kit-Bristle Skirt 34 (34" models / Includes two skirts and mounting hardware)				
	56601450	1	Wheel, 4.00 Od				
	30412A	1	Hose, Solution				

BRUSH SELECTOR GUIDE - DISK

We provide brushes and pad holders that will give you the best possible performance between machine and floor. Following are descriptions of the materials and their applications.

- ProLite:** Bristles are made from light-duty polypropylene for general scrubbing when you do not want to scratch or remove finish from the floor. Recommended for use in place of red pads.
- Prolene:** Polypropylene material for medium-duty scrubbing on concrete, terrazzo and vinyl floor tile. Recommended for use in place of green or blue pads.
- Union Mix:** Medium grade natural fibers for polishing finished floors with standard-speed equipment. Recommended for use in place of white pads.
- AgLite Grit 500:** For light scrubbing when used wet; buffing or polishing when used dry on urethane coated, sealed concrete or other resilient hard surface floors. Recommended for use in place of red or white pads.
- MidGrit 240:** For general purpose scrubbing when you need a lighter action for sealed or unsealed concrete, stone, terrazzo, quarry tile and other resilient hard floor surfaces. Recommended for use in place of green or blue pads.
- MidLite Grit 180:** For general purpose scrubbing of sealed or unsealed concrete, stone, terrazzo, quarry tile and other resilient hard floor surfaces. Recommended for use in place of green or blue pads.
- Dyna Grit 80:** For aggressive, heavy-duty scrubbing or stripping of floors. Recommended for use in place of brown pads.
- Magna Grit 46:** For extreme heavy-duty scrubbing or stripping of floors. This brush has extra large diameter silicon carbide grit impregnated synthetic bristles. Recommended for use in place of black pads.
- Short Trim**
- Pad Holder:** Made with a structural foam block and center ring for correct pad centering. It has a "shower feed" design for getting solution to the floor.

26" BRUSHES

56505760 - Short Trim Pad Holder
 56505195 - Pad Retainer for 56505760
 56505765 - ProLite
 56505764 - Prolene
 56505766 - Union Mix
 56505763 - AgLite Grit 500
 56505767 - MidGrit 240
 56505768 - MidLite Grit 180
 56505762 - Dyna Grit 80
 56505761 - Magna Grit 46

28" BRUSHES

56505800 - Short Trim Pad Holder
 56505195 - Pad Retainer for 56505800
 56505805 - ProLite
 56505804 - Prolene
 56505806 - Union Mix
 56505803 - AgLite Grit 500
 56505807 - MidGrit 240
 56505808 - MidLite Grit 180
 56505802 - Dyna Grit 80
 56505801 - Magna Grit 46

34" BRUSHES

56505780 - Short Trim Pad Holder
 56505195 - Pad Retainer for 56505800
 56505785 - ProLite
 56505784 - Prolene
 56505786 - Union Mix
 56505783 - AgLite Grit 500
 56505787 - MidGrit 240
 56505788 - MidLite Grit 180
 56505782 - Dyna Grit 80
 56505781 - Magna Grit 46

DISC BRUSH APPLICATION GUIDE (SUGGESTION ONLY)

	46	80	180	240	500			Union
Application	Grit	Grit	Grit	Grit	Grit	Prolene	Prolite	Mix
Stripping:								
Concrete	X	X						
Terrazzo	X	X						
Ceramic/Quarry tile		X						
Vinyl tile		X						
General Scrubbing:								
Concrete	X	X	X	X		X		
Terrazzo			X	X	X	X		
Ceramic/Quarry tile			X	X	X	X		
Marble					X		X	
Vinyl tile			X		X	X		
Raised-rubber tile					X		X	
Polishing:								
Raised Disc Tile								X
Marble								X
Vinyl tile								X

BRUSH SELECTOR GUIDE - CYLINDRICAL

We provide brushes and pad holders that will give you the best possible performance between machine and floor. Following are descriptions of the materials and their applications.

Soft Nylon:	Least aggressive brush available. Used on soft-finish floors where a more aggressive brush would leave scratch marks, or in applications requiring very light cleaning.
Stiff Nylon:	Cleaning action similar to polypropylene. More durable and wear-resistant than polypropylene.
Prolene:	Low cost, yet effective in cleaning many common floor surfaces.
MidLite Grit 180:	Least aggressive grit brush. Used for daily cleaning of hard-finished floors.
Dyna Grit 80:	Medium aggressive grit brush. Good all-around brush for medium to heavy buildup removal. Can also be used for general stripping operations.
Magna Grit 46:	Most aggressive grit brush. Used primarily to clean heavy buildup on concrete floors in factories, or for heavy stripping of finish.

28" BRUSHES

56412191 - Soft Nylon
 56412192 - Hard Nylon
 56412046 - Prolene
 56412193 - MidLite Grit 180
 56412194 - Dyna Grit 80
 56412195 - Magna Grit 46

34" BRUSHES

56407473 - Soft Nylon
 56407474 - Hard Nylon
 56407475 - Prolene
 56407476 - MidLite Grit 180
 56407477 - Dyna Grit 80
 56407478 - Magna Grit 46

CYLINDRICAL BRUSH APPLICATION GUIDE (SUGGESTION ONLY)

Application	46 Grit	80 Grit	180 Grit	Polypropylene	Stiff Nylon	Soft Nylon
Stripping:						
Concrete	X	X				
Terrazzo	X	X				
Ceramic/Quarry tile		X				
Vinyl tile		X				
General Scrubbing:						
Concrete	X	X	X	X	X	
Terrazzo			X	X	X	X
Ceramic/Quarry tile			X	X	X	X
Marble			X		X	X
Vinyl tile			X	X	X	X
Raised-rubber tile			X			X

SQUEEGEE BLADE SELECTOR GUIDE

Gum Rubber: Provides superior wiping action on tile, terrazzo, and polished floors.

Red Gum Rubber: Provides longest life on finished or unfinished concrete floors.

Polyurethane: Oil resistance provides superior life in applications with oily floors.

SQUEEGEE BLADE APPLICATION GUIDE(SUGGESTION ONLY)			
Performance Traits	Gum Rubber (Natural Rubber)	Red Gum Rubber (Natural Rubber)	Polyurethane/ Pentathane
Tear Strength		X	X
Abrasion Resistance		X	X
Applications			
Oil Resistant Applications			X
Appearance	Tan	Red	Translucent



Nilfisk-Advance Equipamentos de Limpeza Ltda.
Av. Dep. Emílio Carlos, 2.499 - Bairro do Limão - 02721-200
São Paulo - SP - Brasil
www.nilfisk-advance.ind.br
www.plataforma.ind.br
Tel.: (11) 3959-0300
Fax: (11) 3959-0306
©2015 Nilfisk-Advance, Inc.



14600 21st Avenue North
Plymouth, MN 55447-3408
www.advance-us.com
Phone: 800-989-2235
Fax: 800-989-6566
©2015 Nilfisk-Advance, Inc.

A Nilfisk-Advance Brand