



Electronic Service Manuals

This electronic document is provided as a service to our customers. We do not create the contents of the information contained in this document. Should you have detailed questions pertaining to the information contained in this document, you may contact Michco, or the manufacturer which provided the original information in this electronic deliverable. Michco's only part in this electronic deliverable was the electronic assembly process. By providing this manual on line we are not guaranteeing parts availability.

You may contact Michco through the following methods:

Phone (517) 484-9312 or (800) 331-3339

2011 N. High St. -- Lansing, Michigan -- 48906

Fax: (517) 484-9836

Email: CustServe@Michco.com

Web site: www.Michco.Com

Parts Web site: www.FloorMachineParts.Com

Order Parts on Line at:

www.FloorMachineParts.Com

Directly to Parts & Service:

By Email: **Shop@Michco.com**

By Fax: (517) 702-2041

By Voice: Use numbers above.

Serving the Cleaning Industry Since 1922

Notice: All copyrighted material remains property of original owners, all trademarks are property of respective owners. Manuals are subject to Manufacturer's reproduction limitations. Originals or reproductions were provided by manufacturers through a request. We make no warranty as to the correctness of information provided in this document and you assume all risk. By placing these manuals on line we are not declaring our corporation to be an manufacturer authorized dealer or provider, please check our web site for authorized manufacturers we represent.

ConvertaMAX™ 20/26

BA 550 / BA 650

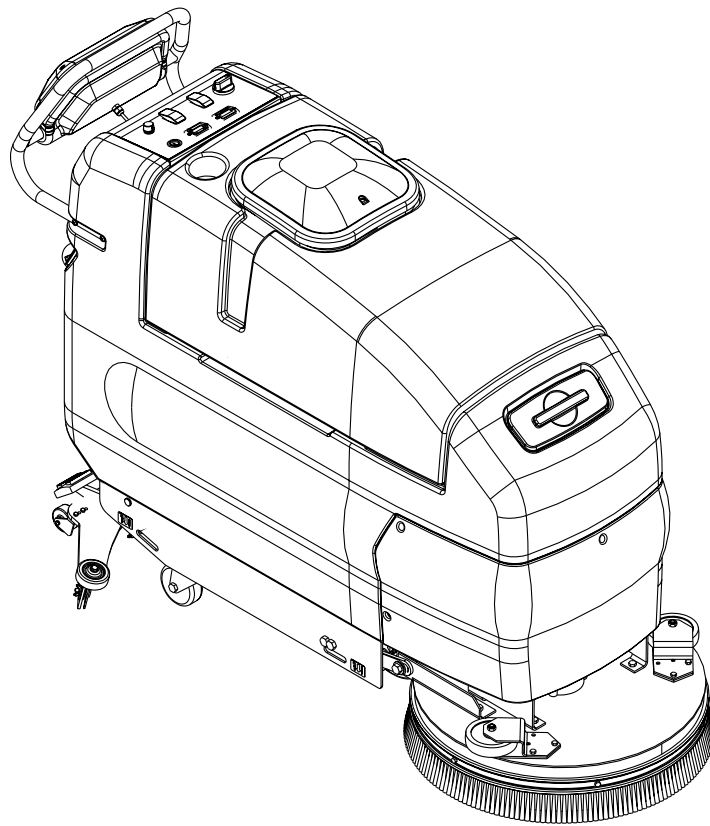

PARTS LIST

Advance MODELS 56397580, 56397581

Nilfisk MODELS 56397582, 56397583

ConvertaMAX 20 after SN1573666 / ConvertaMAX 26 after SN1573671

BA 550 after SN1573798 / BA 650 after SN1573803



**Nilfisk
Advance**
setting standards

4/02 revised 5/04 FORM NO. 56042432
BOOK E SECTION 12.6.1

<u>DESCRIPTION</u>	<u>PAGE</u>
CHASSIS SYSTEM	2-3
DECAL SYSTEM	4-5
ELECTRICAL SYSTEM	6-7
HANDLE SYSTEM	8-9
RECOVERY SYSTEM	10-11
SCRUB DECK SYSTEM-20" (before SN1759839)	12-13
SCRUB DECK SYSTEM-20" (after SN1759838)	14-15
SCRUB DECK SYSTEM-26"	16-17
SKIRT ASSEMBLIES-26"	18-19
SOLUTION SYSTEM	20-21
SQUEEGEE SYSTEM-20"	22-23
SQUEEGEE SYSTEM-26"	24-25
WIRING DIAGRAM	26-27
BRUSH SELECTOR GUIDE	28

WHEN ORDERING PARTS

- * Use the 8 digit numbers from the "Ref. No." columns in this parts list.
- * Specify the model and serial number of the machine.
- * Use the space below to record the model and serial number for future reference.

Model _____ Serial No. _____

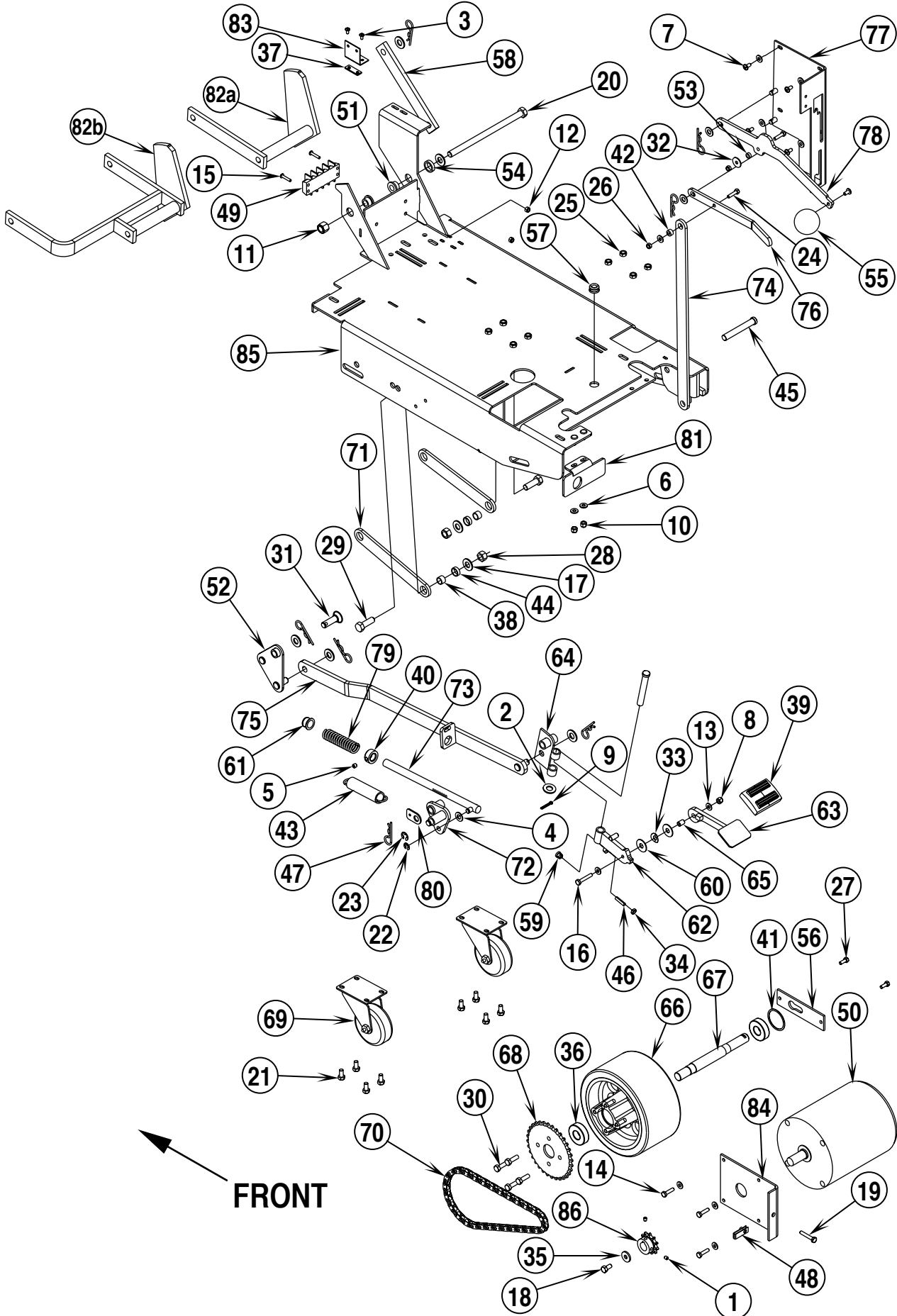

02-4	CHASSIS SYSTEM	BOOK E		
04-5	ConvertaMAX™ 20, 26 / BA 550, 650	E	12.6.1	3

Item	Ref. No.	Qty	Description	Item	Ref. No.	Qty	Description
1	56001841	2	Scr, Soc Set Loc 1/4-20 x .25	46	56003522	1	Screw, Set
2	56001879	6	Wsh, Flt SAE 1/2	47	56003644	7	Pin, Cotter Hair .12 x .50
3	56002043	2	Scr, Pan Phil 10-24 x .38	48	56009289	1	Nut, U Multi-Thread 1/4-20
4	56002063	3	Wsh, Flt SAE 3/8	49	56026111	1	Term. Block, 4Term. 50 Amp
5	56002086	1	Scr, Soc Set Loc 5/16-18 x .25	50	56026191	1	Motor, 24VDC 1/2HP (Wheel Drive / M2)
6	56002098	7	Wsh, Flt SAE 1/4				TSBUS2003-838 / NOTE #1
7	56002145	5	Scr, Pan Phil 1/4-20 x .50	56396311	1	Motor, 24VDC 1/2 HP (Wheel Drive / M2)	
8	56002491	1	Nut, Hex Nyl Loc SS 1/4-20				TSBUS2003-838 / NOTE #2
9	56002529	1	Pin, Cotter 1/8 x 1.00	*	56397099	1	Bearing, BE
10	56002708	2	Nut, Hex Nyl Loc 1/4-20	*	56397135	1	Bearing, FE
11	56002770	1	Nut, Hex Nyl Loc 1/2-13	*	56397138	4	Brush Spring
12	56002836	2	Nut, Hex Nyl Loc SS 10-24	*	56397139	4	Brush Assembly
13	56002859	5	Wsh, Flt SAE SS 1/4	*	56397137	1	Brush Board
14	56002883	3	Scr, Hex Hd SS 1/4-20 x 1.00	51	56027131	2	Bearing, Flange
15	56002898	2	Scr, Pan Phil SS 10-24 x 1.00	52	56035589	1	Weld't, Linkage, Triangular
16	56002901	1	Scr, Hex Hd SS 1/4-20 x 1.50	53	56054335	1	Spacer, Steel
17	56002918	2	Wsh, Flt SAE SS 1/2	54	56054581	1	Spacer, Steel
18	56002929	1	Scr, Hex Hd Loc 5/16-18 x .62	55	56057391	1	Ball Knob
19	56003125	1	Scr, Hex Thd To Hd SS 1/4-20 x 1.50	56	56057763	1	Bar, Steel
20	56003159	1	Scr, Hex Hd 1/2-13 x 8.50	57	56057764	1	Bushing, Guide
21	56003178	8	Scr, Hex M8-1.25 x 16mm	58	56057771	1	Bar, Steel
22	56003262	1	Ring, Ret Ext Type E .38 Dia.	59	56057842	1	Plug, Button
23	56003264	1	Ring, Ret Ext Type E .50 Dia.	60	56151068	2	Washer, Fibre
24	56003358	2	Scr, Hex M6-1.00 x 25mm	61	56393792	1	Bearing, Flange
25	56003389	8	Nut, Hex Nyl Loc M8-1.25	62	56396239	1	Weldment, Pedal Lever
26	56003403	2	Nut, Hex Nyl Loc M6-1.00	63	56396240	1	Weldment, Pedal Lever
27	56003431	2	Scr, Hex Hd SS M6-1.00 x 16mm	64	56396244	1	Weldment, Foot Pedal Pivot
28	56003450	2	Nut, Hex Nyl Loc SS M12-1.75	65	56396249	1	Bushing
29	56003453	2	Scr, Hex Hd SS M12-1.75 x 35mm	66	56397001	1	Wheel
30	56003477	4	Scr, Hex Loc SS M8-1.00 x 25mm	67	56397003	1	Axle
31	56003520	1	Pin, Hitch Cotterless	68	56397005	1	Sprocket
32	56009002	1	Wsh, Flt .266 x .906 x .060	69	56397016	2	Wheel, Caster
33	56009024	1	Wsh, Bowed .375 x .844 x .060	**	56396253	2	Wheel, Caster
34	56009087	1	Nut, Hex Jam 1/4-20	70	56397017	1	Chain, #40-32
35	56009122	1	Wsh, Flt .344 x .938 x .125	71	56397049	2	Arm
36	56154091	2	Bearing, Ball	72	56397054	1	Pivot, Foot Weld't.
37	56324310	1	Nut Plate	73	56397057	1	Rod Weld't.
38	56360627	2	Bushing	74	56397060	1	Linkage, Brush Lift
39	56365002	1	Pad, Rubber	75	56397062	1	Bar Weld't.
40	56367354	1	Collar, Shaft	76	56397063	1	Bar
41	56444731	1	Ring, Ret Int	77	56397064	1	Weld't. Panel
42	56453691	1	Spacer	78	56397086	1	Arm
43	56456847	1	Spring, Extension (26" models only)	79	56397131	1	Compression Spring
44	56478781	2	Bearing, Sleeve	80	56397132	1	Plate(26" models only)
45	56003519	2	Clevis Pin .50 x 3.50	81	56397136	1	Bracket, Rear Cover
				82a	56397146	1	Weld't, Brush Lift (20" models only)
				82b	56397197	1	Weld't, Brush Lift (26" models only)
				83	56397199	1	Bracket, Switch
				84	56397567	1	Bracket, Tension-Traction Drive
				85	56397569	1	Weld't, Frame
				86	56741122	1	Sprocket

* = Not Shown

** = Not Included (optional)

NOTE #1: BA 550 before SN1645714 / BA 650 before SN1645725 / ConvertaMAX 20 before SN1646755 / ConvertaMAX 26 before SN1646758

NOTE #2: BA 550 after SN1645713 / BA 650 after SN1645724 / ConvertaMAX 20 after SN1646754 / ConvertaMAX 26 after SN1646757

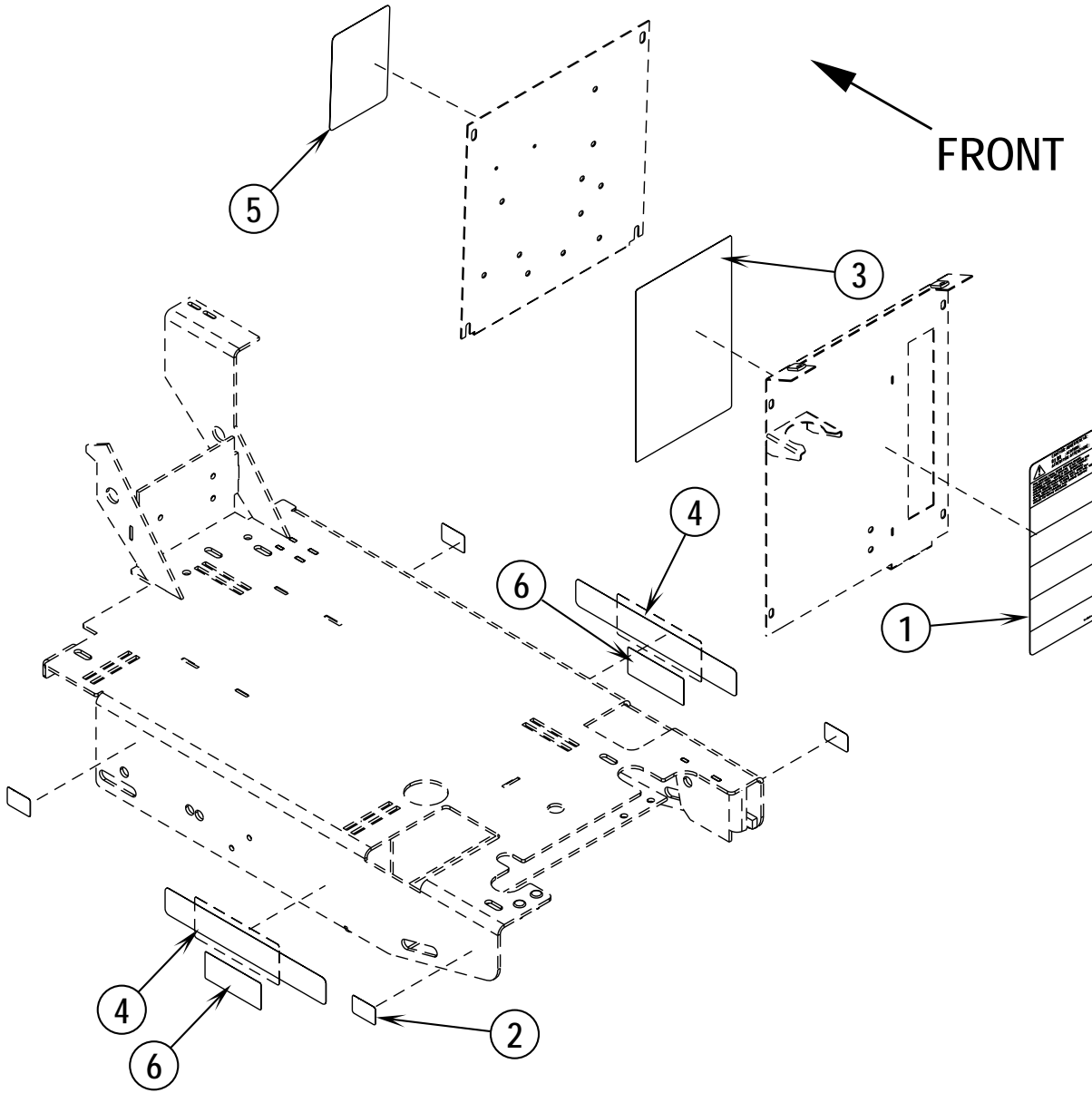

02-4	DECAL SYSTEM	BOOK E		
04-3	ConvertaMAX™ 20, 26 / BA 550, 650	E	12.6.1	5

Item	Ref. No.	Qty	Description
1	56014601	1	Decal, Caution
2	56015370	4	Decal, Tie Down
3	56016321	1	Decal, Elect. Schematic
4	56016648	2	Decal, ConvertaMAX 20
	56016649	2	Decal, ConvertaMAX 26 (before serial #1735164)
	56016681	2	Decal, CMAX 26 (after serial #1735163)
	56016650	2	Decal, BA550
	56016651	2	Decal, BA650
5	56016653	1	Decal, Battery Wiring
6	56016680	1	Decal, Smart Solutions (CMAX 26 after serial #1735163)

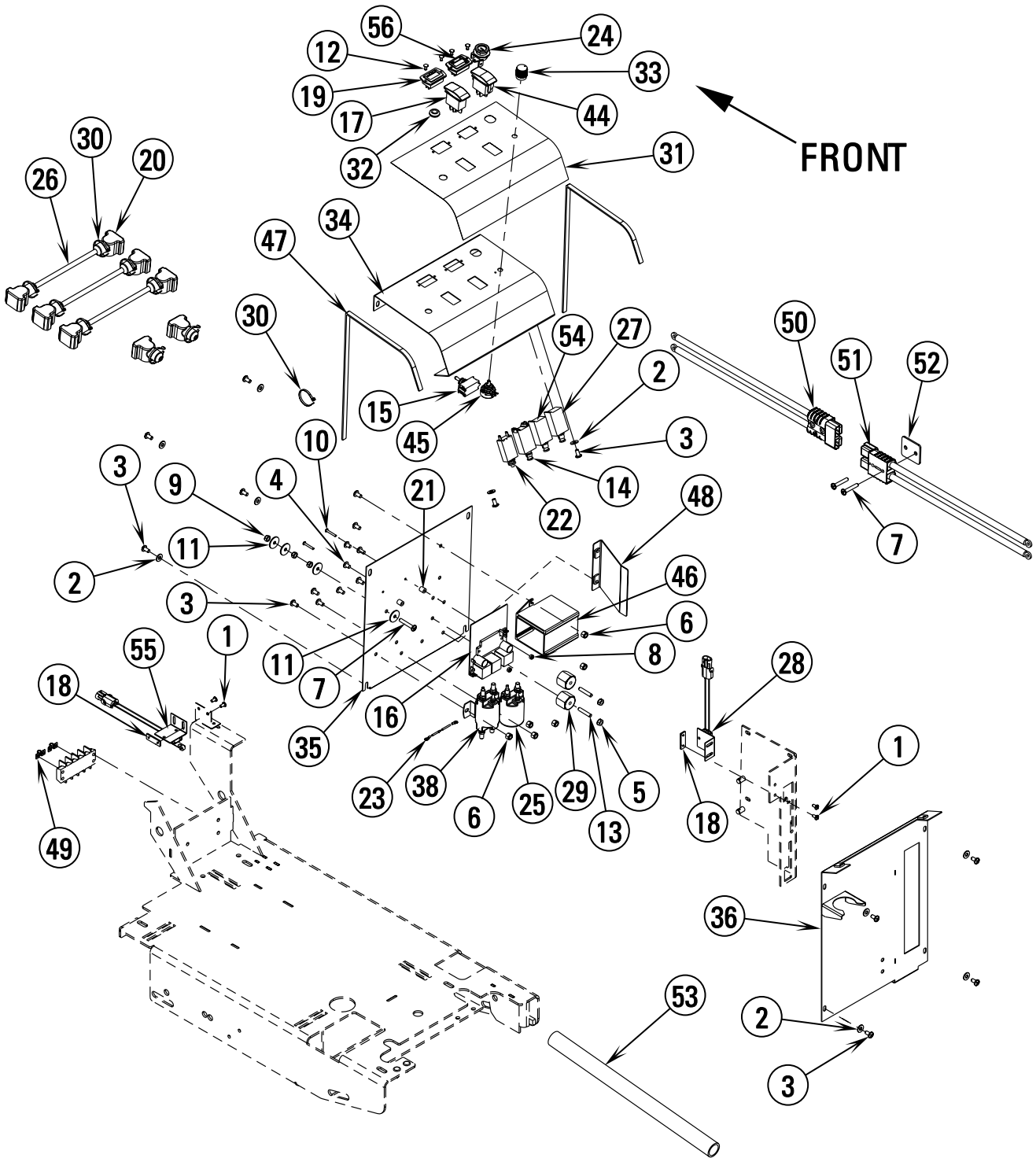

02-4	ELECTRICAL SYSTEM	BOOK E		
04-5	ConvertaMAX™ 20, 26 / BA 550, 650	E	12.6.1	7

Item	Ref. No.	Qty	Description	Item	Ref. No.	Qty	Description
1	56002043	4	Scr, Pan Phil 10-24 x .38	44	56397122	1	Switch, Rocker (Brush Remove / S3)
2	56002098	10	Wsh, Flt SAE 1/4	45	56397123	1	Potentiometer, 25K (Speed Limit / R1)
3	56002145	18	Scr, Pan Phil 1/4-20 x .50	46	56397124	1	Timer Module Assy (A2)
4	56002462	2	Scr, Pan Phil 1/4-20 x .38	47	56397149	2	Gasket
5	56002561	2	Nut, Hex W/SHPRF 1/4-20	48	56397164	1	Guard
6	56002708	6	Nut, Hex Nyl Loc 1/4-20	49	56397184	2	Plate, Jumper (26" models only)
7	56002786	3	Scr, Pan Phil 1/4-20 x 1.50	50	56397187	1	Connector Assy (connected to batteries)
8	56002830	2	Nut, Hex Nyl Loc 6-32	*	56100621	1	Connector Housing, 24V Red
9	56002840	3	Nut, Hex Nyl Loc-Thin 1/4-20	*	56100685	2	#4 Contact
10	56002858	2	Scr, Pan Phil 6-32 x 1.00	51	56397188	1	Connector Assy (connected to machine)
11	56009060	4	Wsh, Flt SS .260 x 1.000 x .074	*	56100621	1	Connector Housing, 24V Red
12	56009192	4	Rivet, Push Nylon Black	*	56100685	2	#4 Contact
13	56009203	2	Stud, 1/4-20	52	56397189	1	Spacer
14	56452193	1	Circuit Breaker, 40A (20" models Brush Motor / F2)	53	56397190	1	Conduit
	56263260	1	Circuit Breaker, 60A (26" models Brush Motor / F2)	54	56454423	1	Circuit Breaker, 30A (Wheel Drive / F3)
15	56301636	1	Switch, Toggle (Main Power / S1)	55	56462362	1	Switch Assy, NC (Brush Switch / S6)
16	56324023	1	Speed Control (A1)	56	56393718	1	Hourmeter
17	56324272	1	Switch Rocker (Solution / S2)				
18	56324310	2	Nut Plate	**	56397453	1	Indicator, Battery Level
19	56372089	1	Fuel Gauge, Battery (P1)	**	56026200	4	Battery, 6V, 250A/H
20	56372673	8	Boot, Battery Post	**	56206079	4	Battery, 6V, 235A/H
21	56377721	2	Spacer	**	56372730	4	Battery, 6V, 225A/H
22	56387316	1	Circuit Breaker, 10A (Auxiliary / F1)	**	56206077	4	Battery, 6V, 220A/H
23	56389265	1	Rectifier Assy (D1)	**	56206964	2	Battery, 12V, 105A/H
24	56393325	1	Bracket, Keylock	**	56372947	A/R	Battery Charger, 24V, 20A, 115VAC
*	56393415	1	Replacement Key	*	56057920	1	Spacer, Angle, Batt Comp
25	56412179	1	Contact, 24VDC (Vacuum Motor / K2)				(For use with two 12V Batteries)
26	56416445	3	Cable Assy 4AWG (Battery Interconnect)	*	56397208	1	Spacer, Battery (Advance only)
27	56454423	1	Circuit Breaker, 30A (Vacuum Motor / F4)	*	56398090	8	Terminal Clamp, Battery (Nilfisk only)
28	56462362	1	Switch Assy, NC (Vacuum Switch / S4)				
29	56469858	2	Standoff, Insulated				
30	56478246	14	Tie, Cable	*			* = Not Shown
31	56016652	1	Decal, Instrument Panel (20" models)	**			** = Not Included (optional)
	56016663	1	Decal, Instrument Panel (26" models)				
32	56056190	1	Grommet				
33	56056596	1	Knob				
34	56397025	1	Panel, Instrument				
35	56397027	1	Panel, Front				
36	56397038	1	Panel, Back, Weld't.				
37	56397087	1	Harness, Main (Not Shown) TSBUS2003-838 / NOTE #1				
	56397288	1	Harness, Main (Not Shown) TSBUS2003-838 / NOTE #2				
38	56397088	1	Contact, 24VDC (Brush Motor / K1)				
39	56397114	1	Cable Assy 6 AWG (BLK, 65" Wire #8 / Not Shown)				
40	56397115	1	Cable Assy 6 AWG (RED, 69" Wire #16 / Not Shown)				
41	56397116	1	Cable Assy 6 AWG (RED, 7" Wire #12 / Not Shown)				
42	56397117	1	Cable Assy 6 AWG (RED, 16" Wire #14 / Not Shown)				
43	56397118	1	Cable Assy 6 AWG (RED, 14" Wire #10 / Not Shown)				

NOTE #1: BA 550 before SN1645714 / BA 650 before SN1645725 / ConvertaMAX 20 before SN1646755 / ConvertaMAX 26 before SN1646758
NOTE #2: BA 550 after SN1645713 / BA 650 after SN1645724 / ConvertaMAX 20 after SN1646754 / ConvertaMAX 26 after SN1646757

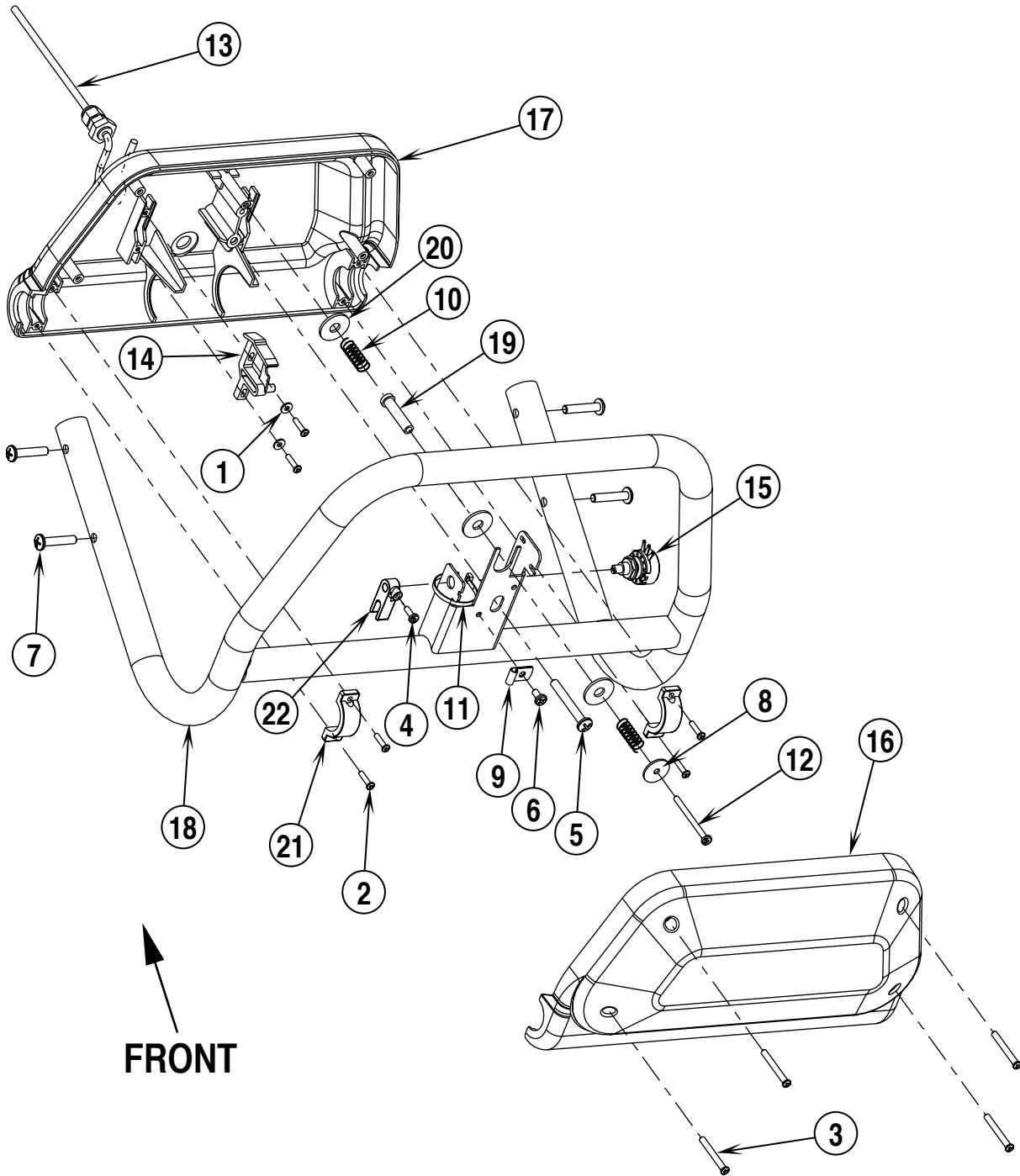

02-4	HANDLE SYSTEM	BOOK E		
03-1	ConvertaMAX™ 20, 26 / BA 550, 650	E	12.6.1	9

Item	Ref. No.	Qty	Description
1	56002006	2	Wsh, Flt SAE #6
2	56003197	6	Scr, Pan Plastite 6-18 x .62
3	56003199	4	Scr, Pan Plastite 8-15 x 1.50
4	56003354	1	Scr, Pan Phil M4 x 12mm
5	56003527	1	Scr, Pan Phil Plastite 1/4-10 x 2.00
6	56009030	1	Scr, Pan Phil Thd Form 10-24 x .38
7	56009090	4	Scr, Pan Phil Loc 1/4-20 x 1.25
8	56009096	1	Wsh, Flt .193 x .875 x .060
9	56220507	1	Clamp, P
10	56325654	2	Spring, Compression
11	56478246	1	Tie, Cable
12	56009287	1	Scr, Pan Phil Type B 8 x 2.00
13	56396233	1	Harness Assembly TSBUS2003-838 / NOTE #1
	56396299	1	Harness Assembly TSBUS2003-838 / NOTE #2
14	56397015	1	Cam Controller
15	56397029	1	Potentiometer, 5K (R2)
16	56397030	1	Paddle, Front Molded
17	56397031	1	Paddle, Back Molded
18	56397034	1	Weldment, Handle
19	56397109	1	Sleeve
20	56397170	3	Washer, Plastic
21	56397171	2	Clamp
22	56397172	1	Potentiometer Fork

NOTE #1: BA 550 before SN1645714 / BA 650 before SN1645725 / ConvertaMAX 20 before SN1646755 / ConvertaMAX 26 before SN1646758

NOTE #2: BA 550 after SN1645713 / BA 650 after SN1645724 / ConvertaMAX 20 after SN1646754 / ConvertaMAX 26 after SN1646757

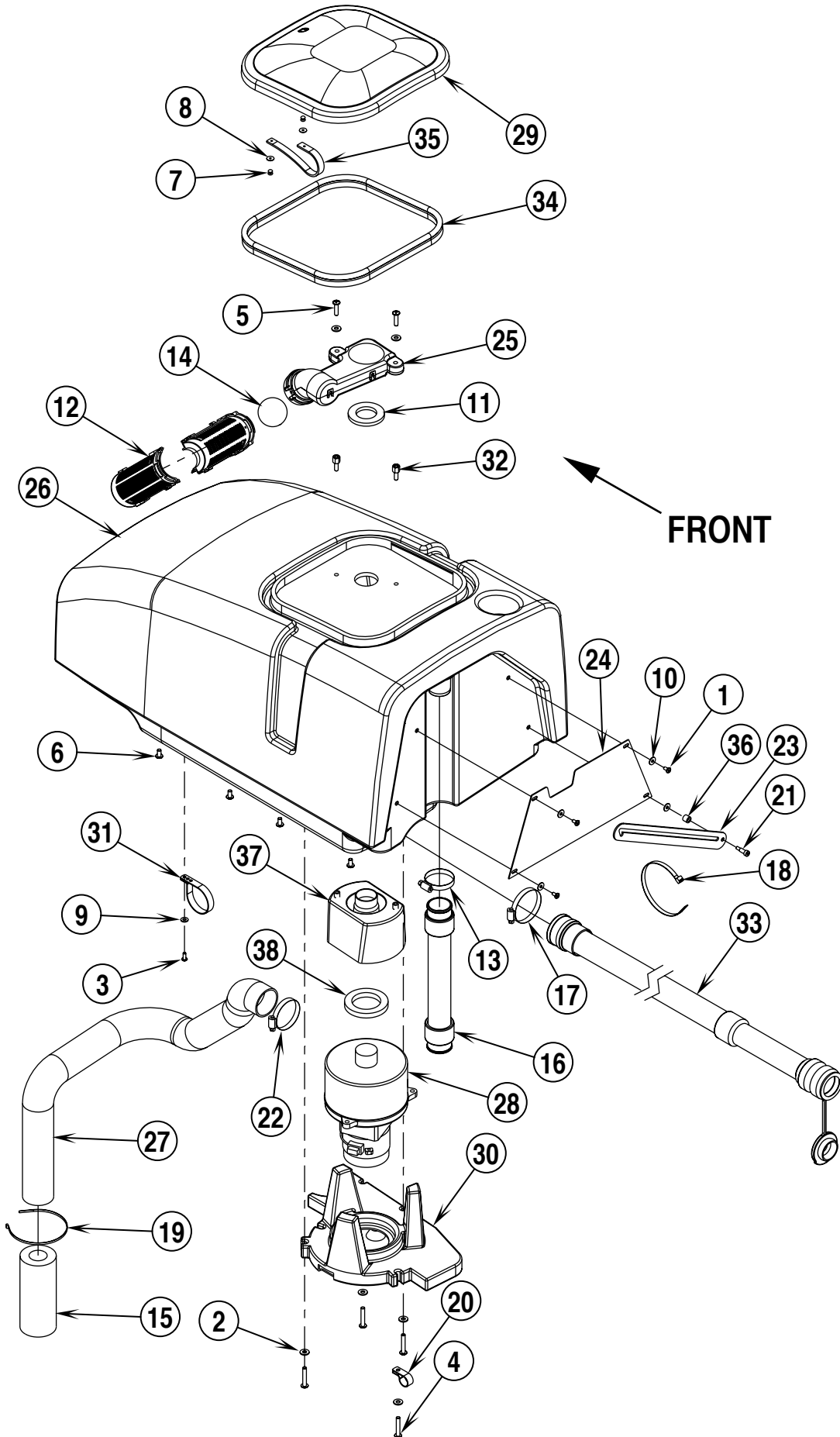

02-4	RECOVERY SYSTEM	BOOK E		
04-5	ConvertaMAX™ 20, 26 / BA 550, 650	E	12.6.1	11

Item	Ref. No.	Qty	Description
1	56002043	3	Scr, Pan Phil 10-24 x .38
2	56002859	6	Wsh, Flt SAE SS 1/4
3	56002900	1	Scr, Pan Phil SS 10-24 x .50
4	56002905	4	Scr, Pan Phil SS 1/4-20 x 1.50
5	56003067	2	Scr, Pan Phil SS 1/4-20 x 1.00
6	56003119	4	Scr, Pan Phil SS 1/4-20 x .50
7	56003293	2	Rivet, Pop A/S .125 x .38 / .50
8	56009098	2	Wsh, Flt SS .125 x .500 x .036
9	56009205	1	Wsh, Flt SS #10
10	56009267	4	Wsh, Flt .202 x .562 x .040
11	56302165	1	Gasket
12	56324497	2	Cage, Float
13	56329145	1	Clamp, Hose SAE #24
14	56391690	1	Ball, Float
15	56391807	1	Foam, Acoustical
16	56392170	1	Hose Assembly
17	56440213	1	Clamp, Hose SAE #32
18	56477613	1	Tie, Cable
19	56478523	1	Tie, Cable
20	56486112	1	Clamp, P
21	56003624	1	Scr, Soc Shd .25 x .50 x 10-24
22	56049999	1	Clamp, Hose SAE #28
23	56057508	1	Bar, Steel
24	56057860	1	Panel, Steel
25	56302142	1	Float Duct
26	56397023	1	Tank, Recovery (Advance)
	56397150	1	Tank, Recovery (Nilfisk)
27	56397040	1	Hose, Vac Exhaust
28	56397041	1	Motor, Vac 24VDC
*	56397098	1	Carbon Brush Set
29	56397045	1	Lid
30	56397046	1	Vac Motor Duct
31	56397095	1	Clamp, Hose
32	56397096	2	Spacer Bolt
33	56397142	1	Drain Hose
34	56397151	1	Gasket
35	56397167	1	Strap, Retaining
36	56397225	1	Spacer, Phenolic
37	56397303	1	Spacer, Vac Motor
38	56397307	1	Gasket, Vac
**	56397450	A/R	Hose / Wand Kit

* = Not Shown

** = Not Included (optional)

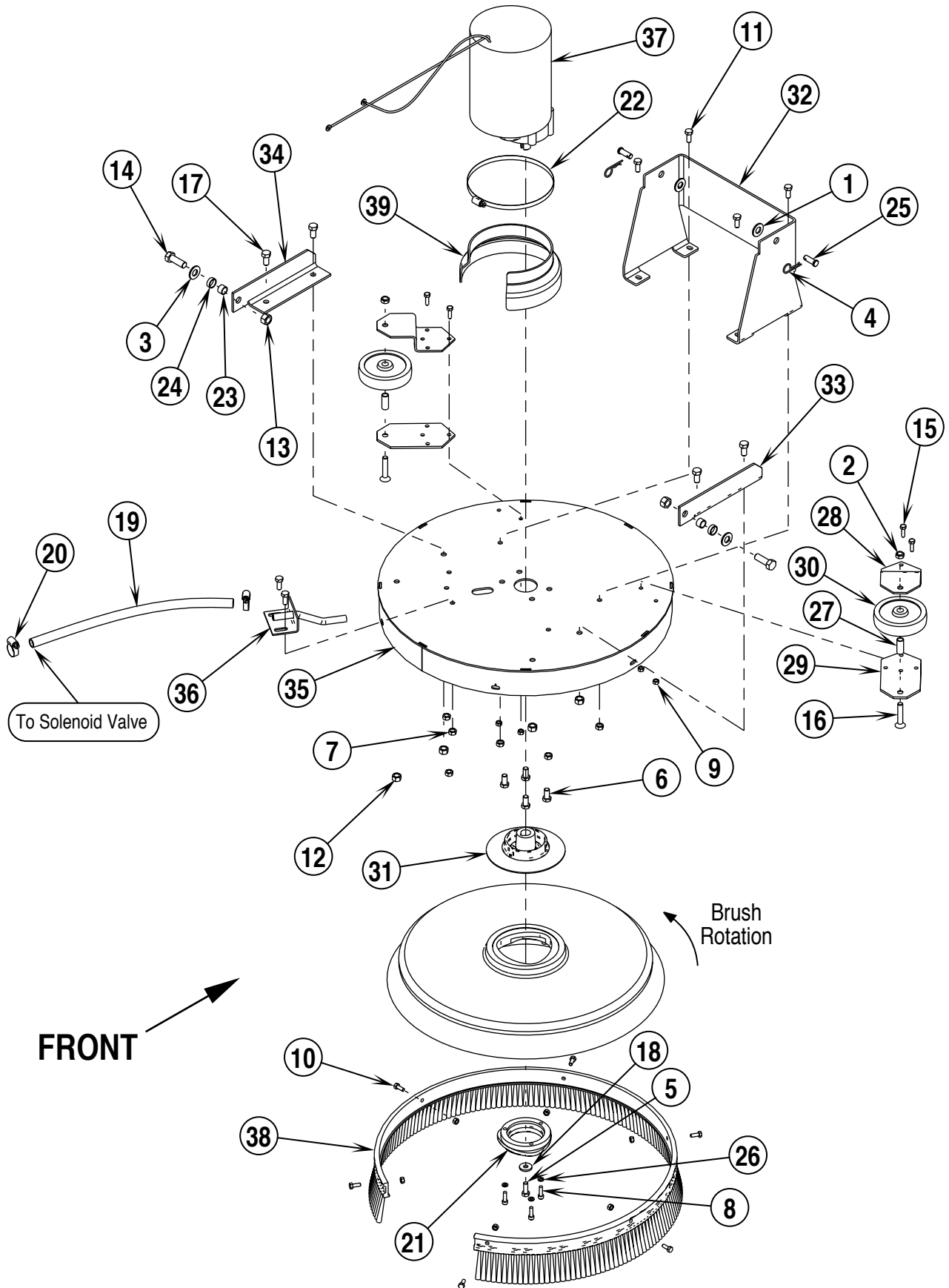

02-4	SCRUB DECK SYSTEM-20" (before SN1759839)	BOOK E		
04-5	ConvertaMAX™ 20, 26 / BA 550, 650	E	12.6.1	13

Item	Ref. No.	Qty	Description
1	56001879	2	Wsh, Flt SAE 1/2
2	56002841	2	Nut, Hex Nyl Loc-Thin 3/8-16
3	56002918	2	Wsh, Flt SAE SS 1/2
4	56002959	2	Pin, Cotter Hair
5	56003335	1	Scr, Hex Loc SS 5/16-18 x .88
6	56003338	4	Scr, Hex Loc SS 3/8-16 x .75
7	56003405	6	Nut, Hex Nyl Loc SS M8-1.25
8	56003424	3	Scr, Socket Hd SS M6-1.00 x 20mm
9	56003426	10	Nut, Hex Nyl Loc SS M6-1.00
10	56003431	6	Scr, Hex Hd SS M6-1.00 x 16mm
11	56003435	6	Scr, Hex Hd SS M8-1.25 x 20mm
12	56003438	4	Nut, Hex Nyl Loc SS M10-1.50
13	56003450	2	Nut, Hex Nyl Loc SS M12-1.75
14	56003453	2	Scr, Hex Hd SS M12-1.75 x 35mm
15	56003454	4	Scr, Hex Thd To Hd SS M6-1.00 x 20MM
16	56003524	2	Scr, Flt Soc 3/8-16 x 2.00
17	56003533	4	Scr, Hex Hd SS M10-1.50 x 20mm
18	56009122	1	Washer
19	56459064	1	Hose, PVC Clear
20	56219932	2	Clamp, Hose SAE #6
21	56325611	1	Drive Lug, Polygon
22	56355488	1	Clamp, Hose SAE #96
23	56360627	2	Bushing
24	56478781	2	Bearing, Sleeve
25	56003523	2	Clevis Pin, .38 x 1.00
26	56003547	3	Wsh, Flt 6.4mm x 11mm x 1.6mm
27	56054018	2	Spacer, Steel
28	56057850	2	Plate, Steel
29	56057873	2	Plate, Steel
30	56111639	2	Wheel
31	56397037	1	Clutch Plate, Aluminum
32	56397070	1	Bracket, U-Brush Head
33	56397072	1	Bracket, Brush Head, Right
34	56397073	1	Bracket, Brush Head, Left
35	56397076	1	Weldment, Brush Head Cover
36	56397078	1	Weldment, Formed Tube
37	56397079	1	Motor (M3)
***	56397090	1	Bearing, B.E.
***	56397135	1	Bearing, F.E.
***	56397138	4	Brush Spring
***	56397139	4	Brush Assy
***	56397092	1	Brush Board Assy (Springs/Brushes)
38	56397111	1	Skirt, Bristle
39	56397112	1	Shroud, Motor
**	56396248	1	Kit, Rubber Splash Guard
**	56325502	1	Pad Holder
**	56325504	1	Brush, Prolene Medium
**	56325505	1	Brush, ProLite Soft
**	56325506	1	Brush, MidLite 180 Grit
**	56325507	1	Brush, MidGrit Medium
**	56325508	1	Brush, Union Mix
**	56505201	1	Brush, MagnaGrit 46
**	56505203	1	Brush, DynaGrit 80
**	56505205	1	Brush, AgLite Grit 500

** = Not Included (optional)

*** = Replacement Parts for 56397079

02-4	SCRUB DECK SYSTEM-20" (after SN1759838)	BOOK E		
04-5	ConvertaMAX™ 20, 26 / BA 550, 650	E	12.6.1	15

Item	Ref. No.	Qty	Description
1	56001879	2	Wsh, Flt Sae 1/2
2	56002625	1	Scr, Soc Shd .38 X 1.50 X 5/16-18
3	56002826	1	Nut, Hex Nyl Loc-Thin 5/16-18
4	56002875	1	Wsh, Flt Sae Ss #8
5	56002876	3	Scr, Pan Phil Ss 8-32x.50
6	56002877	3	Nut, Hex Nyl Loc Ss 8-32
7	56002918	2	Wsh, Flt Sae Ss 1/2
8	56003335	1	Scr Hex Loc Ss 5/16-18 X .88
9	56003338	4	Scr Hex Loc Ss 3/8-16 X .75
10	56003405	6	Nut, Hex Nyl Loc Ss M8x1.25
11	56003424	3	Scr, Socket Head Ss, M6x1.0x20
12	56003435	6	Scr, Hex Hd Ss 8-1.25x20mm
13	56003438	4	Nut, Hex Nyl Loc Ss M10x1.5
14	56003450	2	Nut, Hex Nyl Loc Ss M12x1.75
15	56003453	2	Scr, Hex Hd Ss M12-1.75x35mm
16	56003523	2	Clevis Pin .50 X 1.00
17	56003533	4	Scr, Hex Hd Ss M10-1.5x20mm
18	56003547	3	Wsh, Flt 6.4m X 11mm X 1.6mm
19	56003644	2	Pin, Cotter Hair .120 X .5
20	56009122	1	Wsh, Flt .344 X .938 X .125
21	56035617	1	Strap, Clamp
22	56219932	1	Clamp, Hose Sae #6
23	56228102	1	Wheel
24	56325611	1	Drive Lug, Polygon
25	56355488	1	Clamp, Hose Sae #96
26	56360627	2	Bushing
27	56396247	1	Guard, Splash
28	56397037	1	Clutch Plate, Aluminum
29	56397070	1	Bracket, U-Brush Head 20 In
30	56397072	1	Bracket, Brush Head, Right
31	56397073	1	Bracket, Brush Head, Left
32	56397078	1	Weldment, Formed Tube
33	56397079	1	Motor/Gearbox Assembly (M3)
***	56397090	1	Bearing, B.E.
***	56397135	1	Bearing, F.E.
***	56397138	4	Brush Spring
***	56397139	4	Brush Assy
***	56397092	1	Brush Board Assy (Springs/Brushes)
34	56397112	1	Shroud, Motor
35	56397574	1	Weldment, Brush Cover
36	56459064	1	Hose, Pvc Clear
37	56471194	1	Latch Assembly
38	56478781	2	Bearing, Sleeve
39	56645144	1	Extrusion, Bumper
**	56396248	1	Kit, Rubber Splash Guard (includes #21, 27, 39)
**	56325502	1	Pad Holder
**	56325504	1	Brush, Prolene Medium
**	56325505	1	Brush, ProLite Soft
**	56325506	1	Brush, MidLite 180 Grit
**	56325507	1	Brush, MidGrit Medium
**	56325508	1	Brush, Union Mix
**	56505201	1	Brush, MagnaGrit 46
**	56505203	1	Brush, DynaGrit 80
**	56505205	1	Brush, AgLite Grit 500

** = Not Included (optional)

*** = Replacement Parts for 56397079

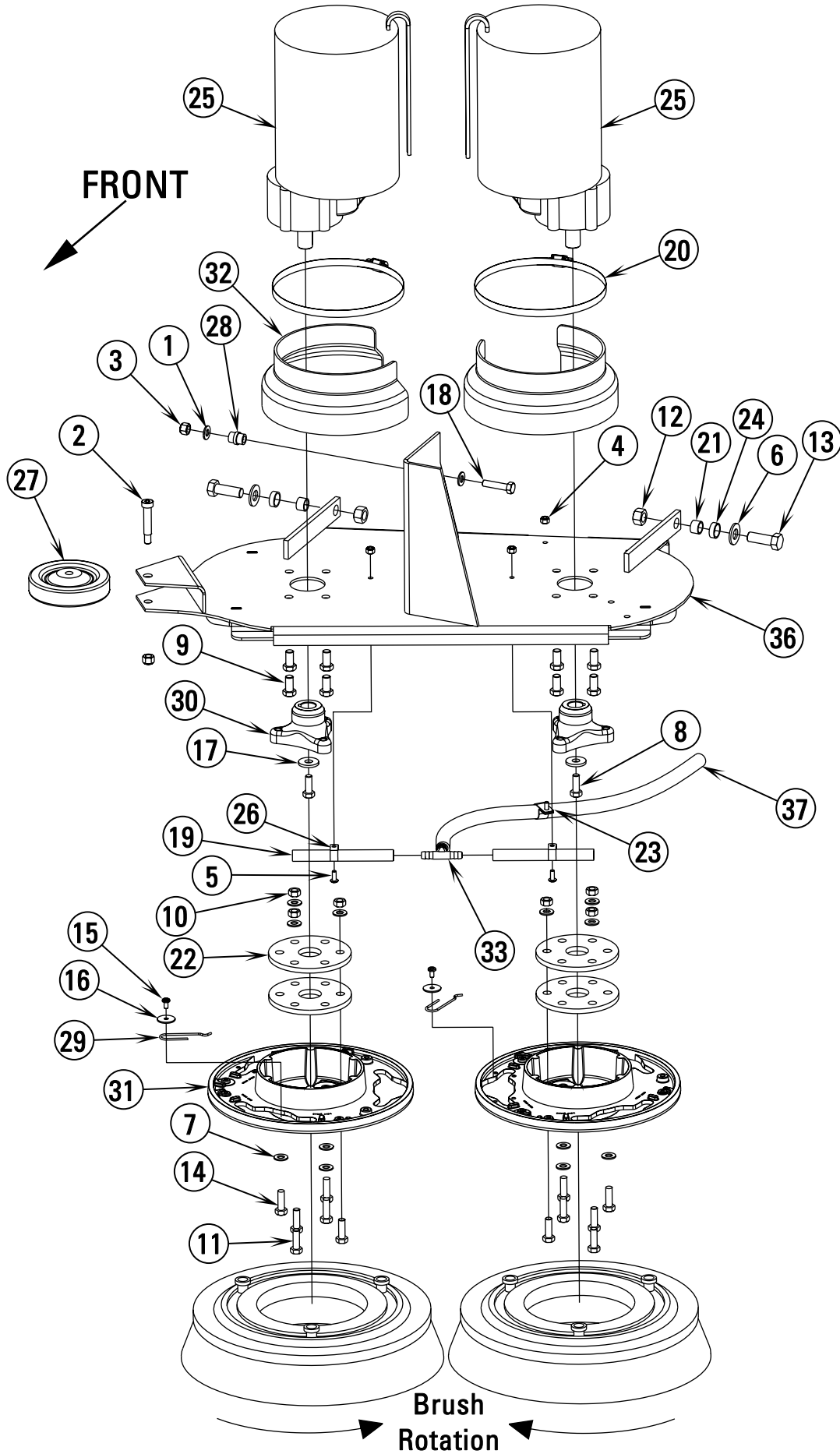

02-4	SCRUB DECK SYSTEM-26"	BOOK E		
03-10	ConvertaMAX™ 20, 26 / BA 550, 650	E	12.6.1	17

Item	Ref. No.	Qty	Description
1	56001939	2	Wsh, Flt SAE 5/16
2	56002625	1	Scr, Soc Shd .38 x 1.50 x 5/16-18
3	56002701	2	Nut, Hex Nyl Loc 5/16-18
4	56002836	3	Nut, Hex Nyl Loc SS 10-24
5	56002900	3	Scr, Pan Phil SS 10-24 x .50
6	56002918	2	Wsh, Flt SAE SS 1/2
7	56002938	12	Wsh, Flt SAE SS 5/16
8	56003335	2	Scr, Hex Loc SS 5/16-18 x .88
9	56003338	8	Scr, Hex Loc SS 3/8-16 x .75
10	56003405	6	Nut, Hex Nyl Loc SS M8-1.25
11	56003436	6	Scr, Hex Hd SS M8-1.25 x 25mm
12	56003450	2	Nut, Hex Nyl Loc SS M12-1.75
13	56003453	2	Scr, Hex Hd SS M12-1.75 x 35mm
14	56003477	6	Scr, Hex Loc SS M8-1.00 x 25mm
15	56009030	2	Scr, Pan Phil Thd Form 10-24 x .38
16	56009096	2	Wsh, Flt .193 x .875 x .060
17	56009107	2	Wsh, Flt SS .378 x 1.000 x .120
18	56009256	1	Scr, Hex Hd 5/16-18 x 1.38
19	56257534	2	Hose, PVC
20	56355488	2	Clamp, Hose SAE #96
21	56360627	2	Bushing
22	56407053	4	Thermoid Disk
23	56442003	1	Clamp, P
24	56478781	2	Bearing, Sleeve
25	56027153	2	Motor / Gearbox Assembly (M3 / M4)
***	56397090	1	Bearing, B.E.
***	56397135	1	Bearing, F.E.
***	56397138	4	Brush Spring
***	56039276	4	Brush Assy
***	56397048	1	Brush Board Assy (Springs/Brushes)
26	56056903	2	Clamp, P
27	56228102	1	Wheel
28	56397024	1	Bushing
29	56397081	2	Spring Retainer
30	56314031	2	Hub, Drive
31	56314030	2	Brush Holder
32	56397112	2	Shroud, Motor
33	56397300	1	Tee, Barb
34	56397560	1	Assy, Brush Cover, Left (following pages)
35	56397561	1	Assy, Brush Cover, Right (following pages)
36	56397571	1	Scrub Deck Weld't.
37	56397599	1	Hose, PVC Clear
**	56505760	2	Pad Holder
**	56505761	2	Magna Grit 46 Brush
**	56505762	2	Dyna Grit 80 Brush
**	56505763	2	AgLite Grit 500 Brush
**	56505764	2	Prolene Brush
**	56505765	2	Prolite Brush
**	56505766	2	Union Mix Polish Brush
**	56505767	2	MidGrit 240 Brush
**	56505768	2	MidLite 180 Brush

** = Not Included (optional)

*** = Replacement Parts for 56027153

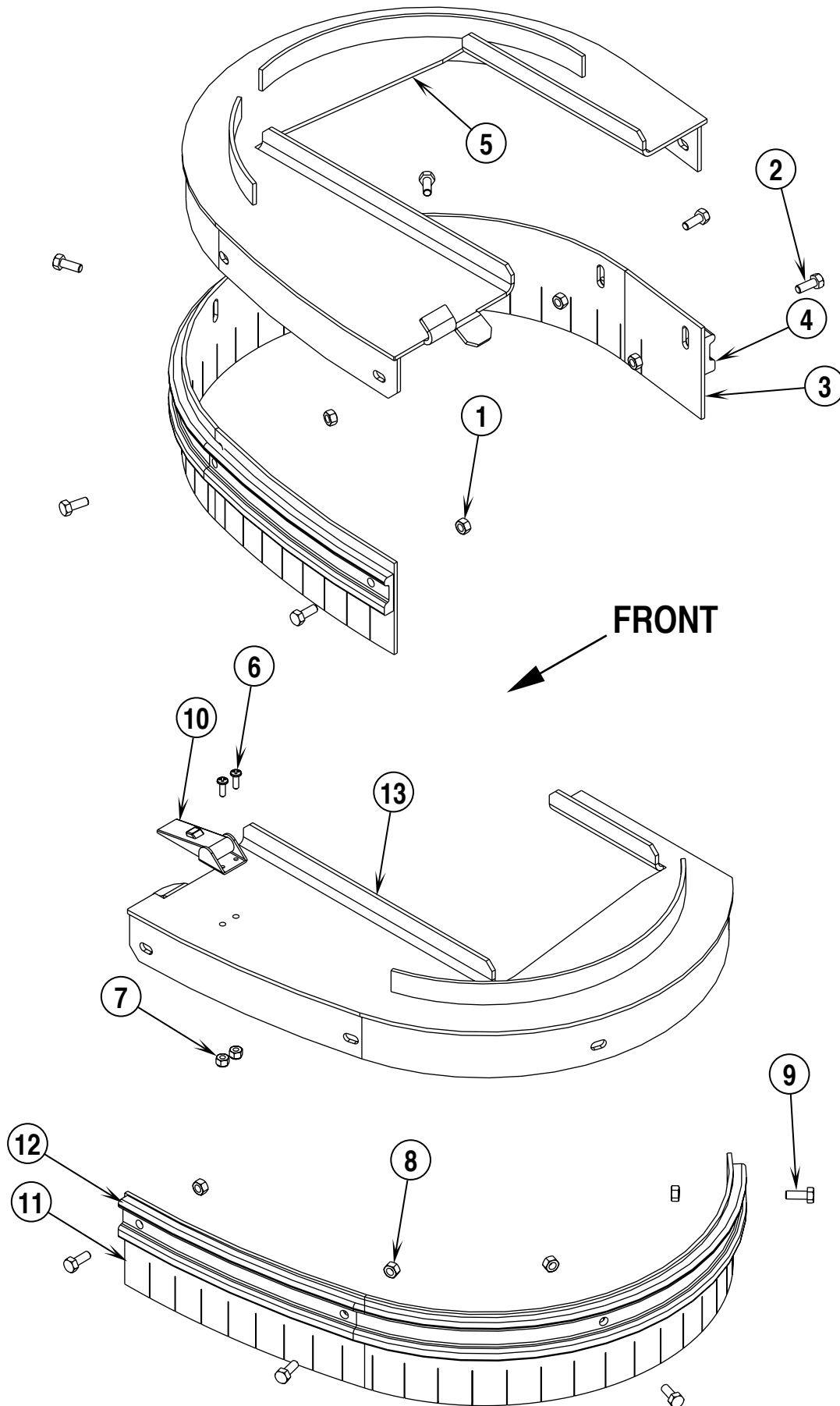

02-4	SKIRT ASSEMBLIES-26"	BOOK E		
04-5	ConvertaMAX™ 20, 26 / BA 550, 650	E	12.6.1	19

Item	Ref. No.	Qty	Description
	56397561	1	Assembly, Brush Cover, Right (#1-5)
	56397560	1	Assembly, Brush Cover, Left (#6-13)
1	56003426	6	Nut, Hex Nyl Loc SS M6-1.00
2	56003431	6	Scr, Hex Hd SS M6-1.00 x 16mm
3	56397000	1	Blade, Right
**	56397346	1	Skirt, Bristle
4	56397004	1	Channel, Right
5	56397563	1	Brush Cover Weld't, Right
6	56002876	2	Scr, Pan Phil SS 8-32 x .50
7	56002877	2	Nut, Hex Nyl Loc SS 8-32
8	56003426	4	Nut, Hex Nyl Loc SS M6-1.00
9	56003431	4	Scr, Hex Hd SS M6-1.00 x 16mm
10	56471194	1	Latch Assembly
11	56397002	1	Blade, Left
**	56397347	1	Skirt, Bristle
12	56397006	1	Channel, Left
13	56397562	1	Brush Cover Weld't, Left
**	56397066	1	Rubber Blade Kit (includes #1, 2, 3, 4, 8, 9, 11, 12)

** = Not Included (optional)

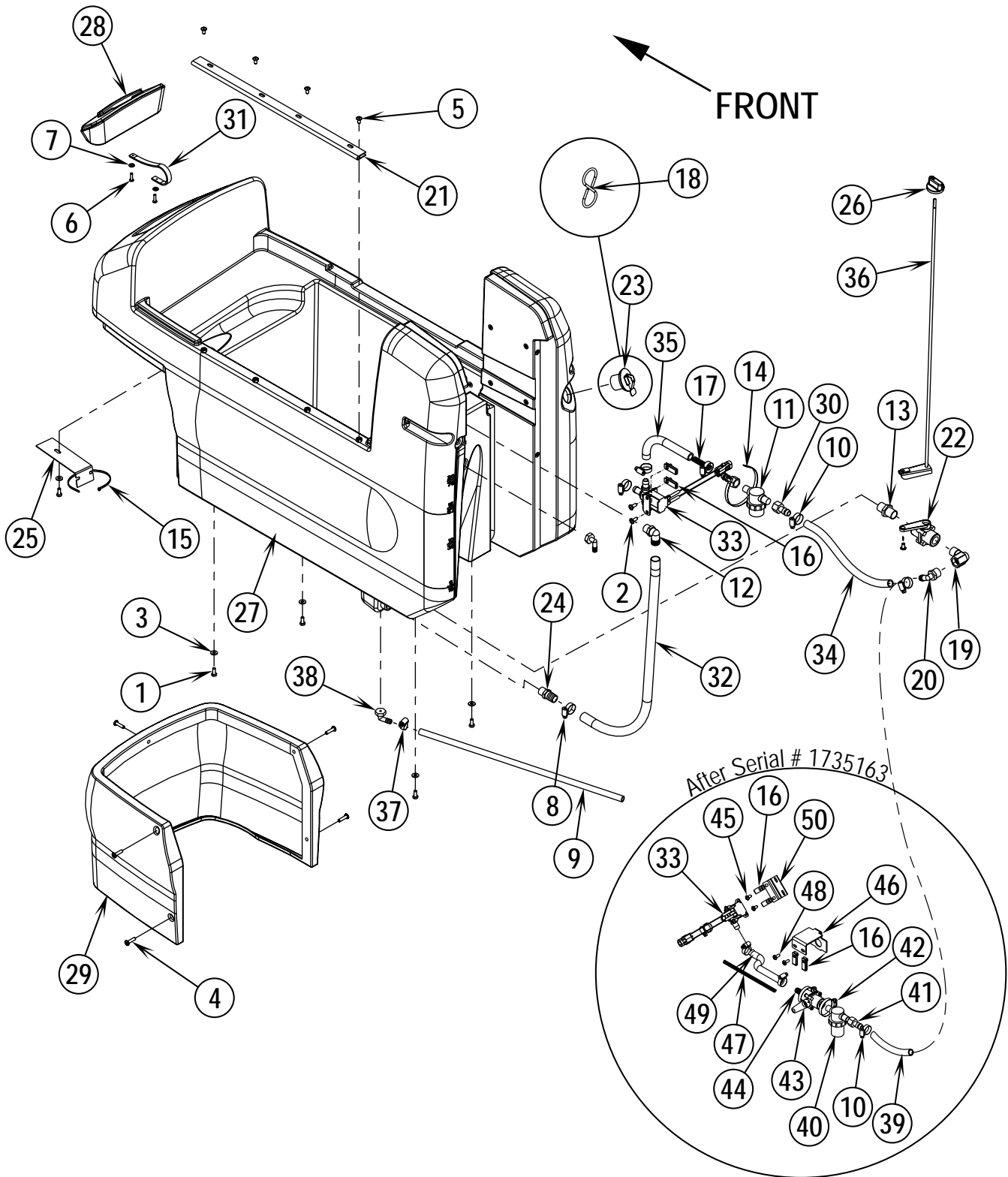

02-4	SOLUTION SYSTEM	BOOK E		
04-5	ConvertaMAX™ 20, 26 / BA 550, 650	E	12.6.1	21

Item	Ref. No.	Qty	Description
1	56001836	5	Scr, Hex Hd 1/4-20 x .62
2	56002066	2	Scr, Pan Phil 1/4-20 x .62
3	56002098	7	Wsh, Flt SAE 1/4
4	56002292	5	Scr, Pan Phil 1/4-20 x 1.00
5	56003119	5	Scr, Pan Phil SS 1/4-20 x .50
6	56009005	2	Scr, Pan Phil SS Type B 10-16 x .75
7	56009205	2	Wsh, Flt SS #10
8	56112771	1	Clamp, Hose SAE #10
9	56201036	1	Hose, PVC
10	56219932	5	Clamp, Hose SAE #6
11	56260905	1	Strainer
12	56264442	1	Barb, 90 Elbow 3/4 x 3/8NPT
13	56412182	1	Nipple, Hex 3/4-14
14	56477613	1	Tie, Cable
15	56478523	1	Tie, Cable
16	56009289	2	Nut, U Multi-Thread 1/4-20 (qty of 4 after serial #1735163)
17	56048979	1	Compression Spring
18	56051836	1	Hook
19	56055071	1	Street Elbow
20	56056231	1	Elbow, Fitting
21	56056514	1	Hinge
22	56057830	1	Valve, Ball
23	56057852	1	Plug, Expansion
24	56057868	1	Fitting, Barb
25	56057904	1	Bracket, Exhaust Hose
26	56396201	1	Knob
27	56397020	1	Tank, Solution
28	56397021	1	Lid, Solution
29	56397022	1	Cover, Front
30	56397145	2	Barb, Hose Female
31	56397167	1	Strap, Retaining
32	56397186	1	Tube, PVC .75
33	56397203	1	Solenoid Valve Assy (L1)
34	56262663	1	Hose, PVC Clear, 7.00
35	56397209	1	Hose, PVC Clear, 5.50
36	56397320	1	Flow Valve Weld't.
37	56756364	1	Clamp, Hose SAE #4
38	56900033	2	Barb, 90 Elbow 3/8 x 1/2NPT
			Components used only after serial #1735163
39	56397382	1	Hose, PVC Clear
40	56396510	1	Strainer
41	56396509	1	Barb, Hose Female
42	56329145	2	Clamp, Hose SAE #24
43	56396505	1	Valve, Solution
44	56412184	1	Barb, Adapter 1/2 x 1/2NPT
45	56002145	4	Scr, Pan Phil 1/4-20 x .50
46	56396506	1	Bracket, Valve
47	56373686	1	Spring, Compression
48	56003213	2	Scr, Pan Phil Blk 1/4-20 x .62
49	56262663	1	Hose, PVC Clear

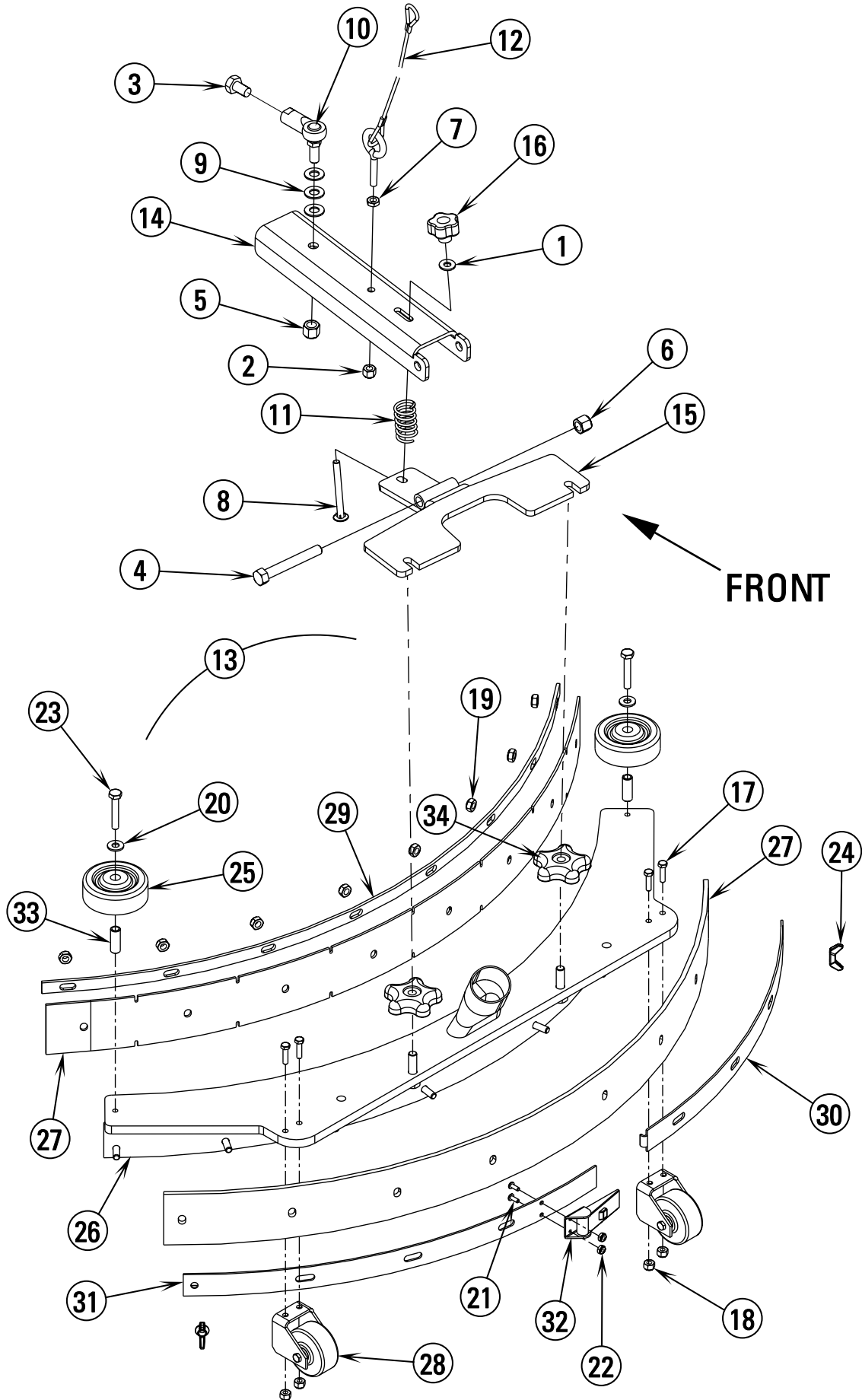

02-4	SQUEEGEE SYSTEM-20"	BOOK E		
04-5	ConvertaMAX™ 20, 26 / BA 550, 650	E	12.6.1	23

Item	Ref. No.	Qty	Description
1	56002098	2	Wsh, Flt SAE 1/4
2	56002856	1	Nut, Hex Nyl Loc SS 5/16-18
3	56002597	1	Scr, Hex Hd 3/8-24 x .75
4	56002903	1	Scr, Hex Hd SS 3/8-16 x 2.75
5	56002951	1	Nut, Hex Nyl Loc 3/8-24
6	56003219	1	Nut, Hex Nyl Loc SS 3/8-16
7	56009141	1	Nut, Hex Jam 5/16-18
8	56009276	1	Scr, Carriage 1/4-20 x 2.50
9	56002063	3	Wsh, Flt SAE 3/8 TSBUS2003-840
10	56397385	1	Rod End TSBUS2003-840
11	56056519	1	Compression Spring
12	56397559	1	Rope, Wire
13	56397100	1	Squeegee Assembly(#17-35)
14	56397104	1	Bracket, Squeegee Mount
15	56397107	1	Weldment, Squeegee Bracket
16	56397108	1	Knob, Squeegee Mount
17	56002835	4	Scr, Hex Hd SS 10-24 x .75
18	56002836	4	Nut, Hex Nyl Loc SS 10-24
19	56002850	8	Nut, Hex Nyl Loc-Thin SS 1/4-20
20	56002859	2	Wsh, Flt SAE SS 1/4
21	56002909	2	Scr, Pan Phil SS 6-32 x .38
22	56002964	2	Nut, Hex Nyl Loc-Thin SS 6-32
23	56002993	2	Scr, Hex Loc SS 1/4-20 x 1.50
24	56009111	2	Nut, Wing SS 1/4-20
25	56363855	2	Wheel
26	56397102	1	Weldment, Squeegee Tool
27	56393395	1	Blade Kit, Standard NOTE #1
**	56393396	1	Blade Kit, Oil Resistant NOTE #1
**	56397329	1	Blade, Front-Tile Gum
28	56393755	2	Roller Assembly
29	56393761	1	Strap, Front
30	56393762	1	Strap, Rear Right
31	56393763	1	Strap, Rear Left
32	56471194	1	Latch Assembly
33	56471220	2	Bushing
34	56396254	2	Knob

** = Not Included (optional)

NOTE #1: All squeegee blade kits include both front and rear squeegee blades.

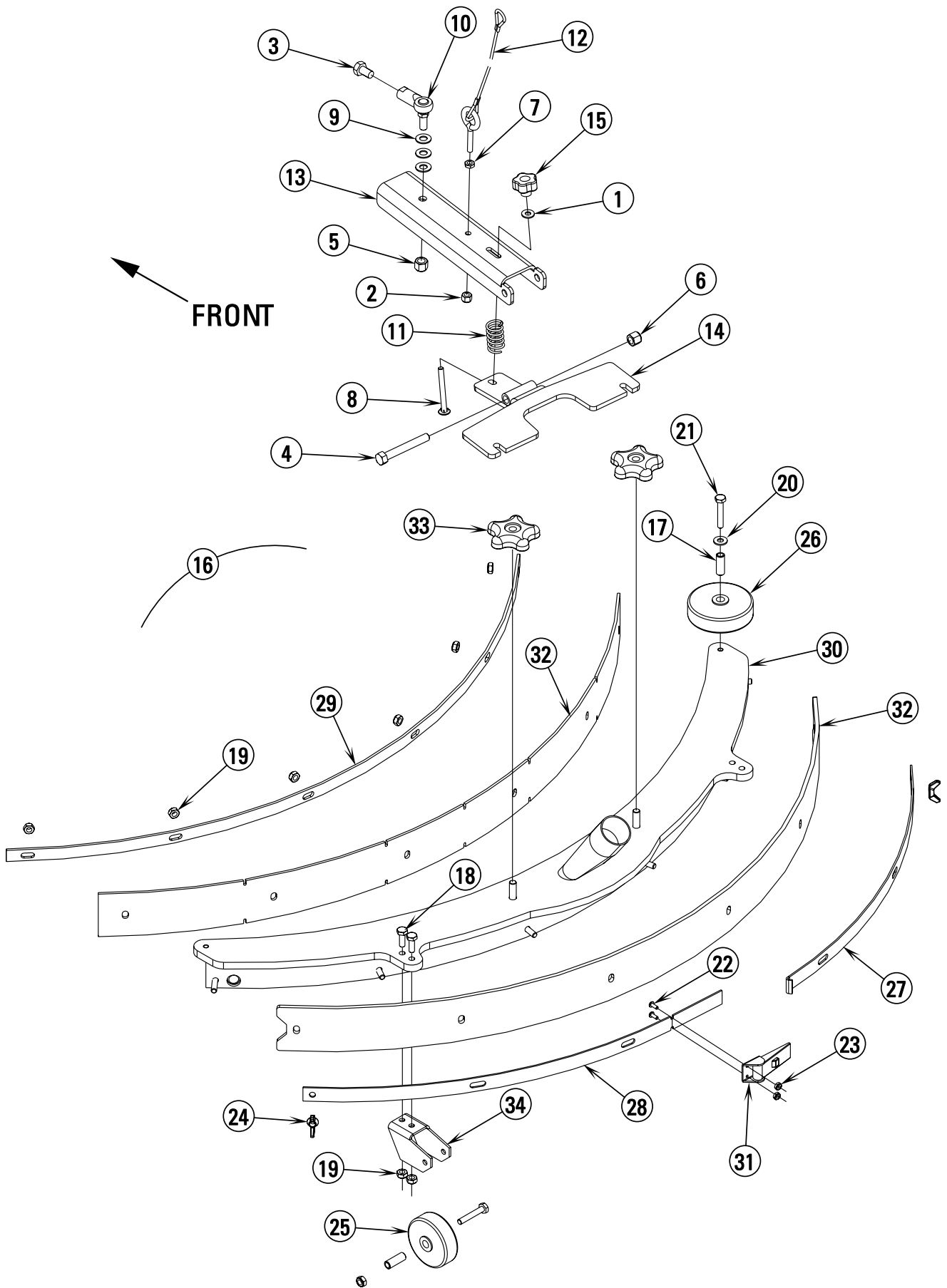

02-4	SQUEEGEE SYSTEM-26"	BOOK E		
04-5	ConvertaMAX™ 20, 26 / BA 550, 650	E	12.6.1	25

Item	Ref. No.	Qty	Description
1	56002098	2	Wsh, Flt SAE 1/4
2	56002856	1	Nut, Hex Nyl Loc SS 5/16-18
3	56002597	1	Scr, Hex Hd 3/8-24 x .75
4	56002903	1	Scr, Hex Hd SS 3/8-16 x 2.75
5	56002951	1	Nut, Hex Nyl Loc 3/8-24
6	56003219	1	Nut, Hex Nyl Loc SS 3/8-16
7	56009141	1	Nut, Hex Jam 5/16-18
8	56009276	1	Scr, Carriage 1/4-20 x 2.50
9	56002063	3	Wsh, Flt SAE 3/8 TSBUS2003-840
10	56397385	1	Rod End TSBUS2003-840
11	56056519	1	Compression Spring
12	56397559	1	Rope, Wire
13	56397104	1	Bracket, Squeegee Mount
14	56397107	1	Weldment, Squeegee Bracket
15	56397108	1	Knob, Squeegee Mount
16	56397185	1	Squeegee Assembly(#17-35)
17	56471220	4	Bushing, .25 x .37 x 1.00
18	56002807	4	Scr, Hex Hd SS 1/4-20 x .75
19	56002850	12	Nut, Hex Nyl Loc-Thin SS 1/4-20
20	56002859	2	Wsh, Flt SAE SS 1/4
21	56002901	4	Scr, Hex Hd SS 1/4-20 x 1.50
22	56002909	2	Scr, Pan Phil SS 6-32 x .38
23	56002964	2	Nut, Hex Nyl Loc-Thin SS 6-32
24	56009048	2	Nut, Wing Loc 1/4-20
25	56324350	2	Wheel
26	56324499	2	Wheel, 3.00
27	56391286	1	Strap, Rear Right
28	56391288	1	Strap, Rear Left
29	56391290	1	Strap, Front
30	56396236	1	Tool Weldment
31	56471194	1	Latch Assembly
32	56391340	1	Blade Kit, Standard NOTE #1
**	56391342	1	Blade Kit, Oil Resistant NOTE #1
**	56397325	1	Blade, Front-Tile Gum
**	56397326	1	Blade, Front-Tile Linatex
33	56396254	2	Knob
34	56409656	2	Bracket, Wheel
35	56471194	1	Latch Assembly

** = Not Included (optional)

NOTE #1: All squeegee blade kits include both front and rear squeegee blades.

Item	Ref. No.	Qty	Description
A1	56324023	1	Speed Control
A2	56397124	1	Timer Module Assy
BT		N/A	Battery
D1	56389265	1	Diode
D2	56460084	1	Diode (Main Wiring Harness)
F1	56387316	1	Circuit Breaker, 10 Amp (Auxiliary)
F2	56452193	1	Circuit Breaker, 40 Amp (20" models / Brush Motor)
	56263260	1	Circuit Breaker, 60 Amp (26" models / Brush Motor)
F3	56454423	1	Circuit Breaker, 30 Amp (Wheel Drive Motor)
F4	56454423	1	Circuit Breaker, 30 Amp (Vac Motor)
K1	56397088	1	Contactor, 24V SPDT (Brush Motor(s))
K2	56412179	1	Contactor, 24 VDC (Vacuum Motor)
L1	56397203	1	Solenoid Valve Assy
M1	56397041	1	Vac Motor
M2	56026191	1	Wheel Drive Motor TSBUS2003-838 / NOTE #1
	56396311	1	Wheel Drive Motor TSBUS2003-838 / NOTE #2
M3	56397079	1	Motor, Brush Drive (20" model)
	56027153	1	Motor / Gear Unit, Brush Drive (26" model)
M4	56027153	1	Motor / Gear Unit, Brush Drive (26" model)
P1	56372089	1	Fuel Gauge, Battery
P2	56393718	1	Hourmeter (Optional)
R1	56397123	1	Potentiometer, 25K
R2	56397029	1	Potentiometer, 5K
S1	56301636	1	Switch, Toggle (Main Power)
S2	56324272	1	Switch, Rocker (Solution)
S3	56397122	1	Switch, Rocker SPST (Brush Remove)
S4	56462362	1	Switch, Vacuum
S6	56462362	1	Switch, Brush
8	56397114	1	Cable Assy 6 AWG
10	56397118	1	Cable Assy 6 AWG
12	56397116	1	Cable Assy 6 AWG
14	56397117	1	Cable Assy 6 AWG
16	56397115	1	Cable Assy 6 AWG
**	56397453	1	Indicator, Battery Level
**	56026200	4	Battery, 6V, 250A/H
**	56206079	4	Battery, 6V, 235A/H
**	56372730	4	Battery, 6V, 225A/H
**	56206077	4	Battery, 6V, 220A/H
**	56206964	2	Battery, 12V, 105A/H
**	56372947	A/R	Battery Charger, 24V, 20A, 115VAC
*	56057920	1	Spacer, Angle, Batt Comp (For use with two 12V Batteries)
*	56397208	1	Spacer, Battery (Advance only)
*	56398090	8	Terminal Clamp, Battery (Nilfisk only)
*	56397087	1	Harness, Main

* = Not Shown

** = Not Included (optional)

NOTE #1: BA 550 before SN1645714 / BA 650 before SN1645725 / ConvertaMAX 20 before SN1646755 / ConvertaMAX 26 before SN1646758

NOTE #2: BA 550 after SN1645713 / BA 650 after SN1645724 / ConvertaMAX 20 after SN1646754 / ConvertaMAX 26 after SN1646757

We provide brushes and pad holders that will give you the best possible performance between machine and floor. Following are descriptions of the materials and their applications.

- Union Mix:** Medium grade natural fibers for polishing finished floors with standard-speed equipment. Recommended for use in place of white pads.
- ProLite:** Bristles are made from light-duty polypropylene for general scrubbing when you do not want to scratch or remove finish from the floor. Recommended for use in place of red pads.
- Prolene:** Polypropylene material for medium-duty scrubbing on concrete, terrazzo and vinyl floor tile. Recommended for use in place of green or blue pads.
- Magna Grit:** For extreme heavy-duty scrubbing or stripping of floors. This brush has extra large diameter silicon carbide grit impregnated synthetic bristles. Recommended for use in place of black pads.
- Dyna Grit:** For aggressive, heavy-duty scrubbing or stripping of floors. Recommended for use in place of brown pads.
- MidLite Grit:** For general purpose scrubbing of sealed or unsealed concrete, stone, terrazzo, quarry tile and other resilient hard floor surfaces. Recommended for use in place of green or blue pads.
- MidGrit:** For general purpose scrubbing when you need a lighter action for sealed or unsealed concrete, stone, terrazzo, quarry tile and other resilient hard floor surfaces. Recommended for use in place of green or blue pads.
- AgLite Grit:** For light scrubbing when used wet; buffing or polishing when used dry on urethane coated, sealed concrete or other resilient hard surface floors. Recommended for use in place of red or white pads.
- Short Trim Pad Holder:** Made with a structural foam block and center ring for correct pad centering. It has a "shower feed" design for getting solution to the floor.

- Ref. No.: 20" BRUSHES**
- 56325502 - Pad Holder
 - 56325504 - Prolene Medium
 - 56325505 - ProLite Soft
 - 56325506 - MidLite 180 Grit
 - 56325507 - MidGrit Medium
 - 56325508 - Union Mix
 - 56505201 - MagnaGrit 46
 - 56505203 - DynaGrit 80
 - 56505205 - AgLite Grit 500

- Ref. No.: 26" BRUSHES**
- 56505760 - Pad Holder
 - 56505761 - MagnaGrit 46
 - 56505762 - DynaGrit 80
 - 56505763 - AgLite Grit 500
 - 56505764 - Prolene
 - 56505765 - Prolite
 - 56505766 - Union Mix
 - 56505767 - MidGrit 240
 - 56505768 - MidLite 180 Grit

DISC BRUSH APPLICATION GUIDE (SUGGESTION ONLY)

Application	46 Grit	80 Grit	180 Grit	240 Grit	500 Grit	Prolene	Prolite	Union Mix
Stripping:								
Concrete	X	X						
Terrazzo	X	X						
Ceramic/Quarry tile		X						
Vinyl tile		X						
General Scrubbing:								
Concrete	X	X	X	X		X		
Terrazzo			X	X	X	X		
Ceramic/Quarry tile			X	X	X	X		
Marble					X		X	
Vinyl tile			X		X	X		
Raised-rubber tile					X		X	
Polishing:								
Raised Disc Tile								X
Marble								X
Vinyl tile								X

Austria (Sales Sub)

Nilfisk-Advance GmbH	Phone: +43
Voralberger Allee 46	1616 58 30 22
A-1230 Wien	Fax: +43
info@nilfisk-advance.at	1616 58 30 40
www.nilfisk-advance.at	

Belgium (Sales Sub)

Nilfisk-Advance NV/SA	Phone: +32
Doornveld Sphere Business Park	(0)2467 60 50
Industrie Asse 3, No. 11	Fax: +32
B-1731 Zellik-Asse	(0)2463 44 16
www.nilfisk-advance.be	

Czech Republic (Sales Sub)

Nilfisk-Advance s.r.o.	Phone: +420
Lysinská 44/1863	2 44 09 09 12
143 00 Praha - Modrany	+420
Czech Republic	2 44 09 09 21 4
	Fax: +420
	2 44 40 23 93

Denmark

Nilfisk-Advance A/S	Phone: +45
Sognevej 25	43 23 81 00
DK-2605 Brøndby	Fax: +45
mail@nilfisk-advance.dk	43 43 77 00
www.nilfisk-advance.com	

Denmark (Prod. Sub)

Gerni A/S	Phone: +45
Myntevej 2	89 12 22 00
DK-8900 Randers	Fax: +45
www.gerni.com	86 43 14 81

Denmark (Sales Sub)

Nilfisk-Advance Nordic A/S	Phone: +45
Sognevej 25A	43 23 40 50
Postbox 344	Fax: +45
DK-2605 Brøndby	43 23 40 60
kundeservice@nilfisk-advance.dk	
www.nilfisk-advance.dk	

France (Sales Sub)

Nilfisk-Advance S.A.	Phone: +33
27 avenue de la Baltique	1695 98 700
Villebon sur Yvette	Fax: +33
P.B. 246	1695 98 701
F-91944 Courtaboeuf Cedex	
info@nilfisk-advance.fr	
www.nilfisk-advance.fr	

Germany (Sales Sub)

Nilfisk-Advance AG	Phone: +49
Siemensstrasse 25-27	4101 3990
Postfach 1361	Fax: +49
D-25462 Rellingen	4101 39 91 91
info@nilfisk-advance.de	
www.nilfisk-advance.de	

Greece (Sales Sub)

Nilfisk-Advance A.E.	Tel.: +30
8, Thoukididou Str.	210 963 3443
Argioupoli	Fax: +30
Gr - 164 52 Athens	210 965 0975
Greece	

Holland (Sales Sub)

Nilfisk-Advance B.V.	Phone: +31
Camerastraat 9 (2e verdieping)	36 546 07 00
1322 BB Almere	Fax: +31
Postbus 60112	36 523 51 48
1320 AC Almere	
www.nilfisk-advance.nl	

Ireland (Sales Sub)

Nilfisk-Advance Limited	Phone: +35
28 Sandyford Office Park	3 12 94 38 38
Sandyford, Dublin 18	Fax: +35
Ireland	3 12 94 38 45

Italy (Prod & Sales Sub)

CFM SpA	Phone: +39
Nilfisk-Advance Div. Guardamiglio	0377 /414021
Localita Novella III	/45 1124
I-26862 Guardamiglio (Mi)	Fax: +39
	0377 51 443

Italy (Prod & Sales Sub)

CFM S.p.A.	Phone: +39
Via Porrettana 1991	059 973 0000
I-41059 Zocca (Modena)	Fax: +39
cfm@cfm.it	059 973 0099

Norway (Sales Sub)

Nilfisk-Advance AS	Phone: +47
Ulvenveien 89C	23 06 75 00
N-0581 Oslo	Fax: +47
	23 06 75 01

Poland (Sales Sub)

Nilfisk-Advance Sp.Z.O.O.	Phone: +48
05-800 Pruszków	22 738 37 50
ul. 3-go MAJA 8	Fax: +48
Poland	22 738 37 51

Portugal (Sales Sub)

Nilfisk-Advance, Lda.	Phone: +35
Sintra Business Park	121 911 2670
Zona Industrial Da Abrunheira	Fax: +35
Edificio 1, 1o A	121 911 2679
P-2710-089 Sintra	

Russia (Sales Sub)

Nilfisk-Advance LLC	Phone: 7
Vyatskaya str. 27, bld. 7	095 783 9602
127015 Moscow	Fax: +7
Russia	095 783 9603

Spain (Sales Sub)

Nilfisk-Advance S.A.	Phone: +34
Torre D'Ara	93 741 2400
Passeig del Rengle, 5 Pl.10	Fax: +34
E-08302 Mataró (Barcelona)	93 757 8020
nilfisk@nilfisk-advance.es	

Sweden (Sales Sub)

Nilfisk -Advance A/S	Phone: +46
Sjöbjörnsvägen 5	8555 94400
Box 44045	Fax: +46
S-100 73 Stockholm	8555 94430
info@nilfisk-advance.se	
www.nilfisk-advance.se	

Sweden (Prod.)

Nilfisk-Advance A/S	Phone: +46
Åmål Branch	5321 7500
Strömsbergsgatan	Fax: +46
Box 127	5321 7595
S-662 23 Åmål	

Switzerland (Sales Sub)

Nilfisk-Advance AG	Phone: +41
Ringsstrasse 19	71 92 38 444
Kirchberg/Industrie Stelzl	Fax: +41
CH-9500 Wil	71 92 35 283

www.nilfisk-advance.ch

UK (Sales Sub)

Nilfisk-Advance Limited	Phone: +44
Newmarket Road	1284 763163
Bury St. Edmunds	Fax: +44
UK-Suffolk IP33 3SR	1284 750 562

USA (Prod.)

Nilfisk-Advance Inc.	Phone: +1 763
14600 21.st Avenue North	745 3500
Plymouth, MN 55447-3408	Fax: +1 763
www.mn.nilfisk-advance.com	745 3718

USA (Sales Sub)

Nilfisk-Advance America Inc.	Phone: +1 610
300 Technology Drive	647 6420
Malvern, PA 19355	Fax: +1 610
www.pa.nilfisk-advance.com	647 6427

Canada (Sales Sub)

Nilfisk-Advance Canada Comp.	Phone: +1 905
396 Watline Avenue	712 3260
Mississauga, Ontario L4Z 1X2	Fax: +1 905
	712 3255

Australia (Sales Sub)

Nilfisk-Advance Pty. Ltd.	Phone: +61(0)2
48 Egerton Street	9648 2700
Silverwater, NSW 2128	Fax: +61(0)2
<i>Postal adresse:</i>	9648 2711
PO Box 6046	
Silverwater. NSW 1811	
info@nilfisk-advance.com.au	
www.nilfisk-advance.com.au	

China (Shenzhen)

Nilfisk-Advance (Shenzhen) Ltd	Phone: +86 755
Blok 3, Unit 130, 1001 Honghua Road	8359 7937 el.
Int. Commercial & Trade Center	8359 7939-42
Fuitian Free Trade Zone	Fax: +86 755
518038 Shenzhen	8359 1063
P.R. China	

China (Suzhou)

Nilfisk-Advance Professional	Phone: +86 512
Cleaning Equipment (Suzhou) Co. Ltd.	8918 5656
306 Su Hong Zhong Road, Build. 2	Fax: +86 512
Suzhou Industrial Park	8918 5666
215021 Suzhou	
P.R. China	

Hong Kong (Sales Sub)

Nilfisk-Advance Ltd.	Phone: +852
2001 HK Worsted Mills Ind'l Bldg.,	2427 5951
31-39 Wo Tong Tsui St.	Fax: +852
Kwai Chung, Hong Kong	2487 5828

Japan (Sales Sub)

Nilfisk-Advance Inc.	Phone: +8145
3-17-40-101 Chigasaki Higashi	942 7741
Tsuzuki-ku, Yokohama 224-0033	Fax: +8145
Japan	942 6545

Malaysia (Sales Sub)

Nilfisk-Advance Sdn Bhd	Phone: +60 3
No. 21, Jalan SS 25/41	7956 8188
Mayang Industrial Park	Fax: +60 3
47301 Petaling Jaya	7966 6828
Selangor, Malaysia	

New Zealand (Sales Sub)

Nilfisk-Advance Limited	Phone: +64(0)9
Danish House	525 0092
6 Rockridge Avenue	Fax: +64(0)9
Penrose 92-829	525 6440
Auckland1135	
<i>Postal adresse:</i>	
Private Bag 92 825	
Auckland	
New Zealand	

Singapore (Sales Sub)

Nilfisk-Advance Pte. Ltd.	Phone: + 65
22,Woodlands Industrial Park E1	6 7599100
Singapore 757740	Fax: +65
sales@nilfisk-advance.com.sg	7599133

Taiwan, ROC (Sales Sub)

Nilfisk-Advance Ltd.	Phone: +886
Taiwan Branch (H.K.)	2 2239 8812
1F, No. 193, Sec.2	Fax: +886
Xing Long Rd., Taipei	2 2239 8832
Taiwan, R.O.C.	

Thailand (Sales Sub)

Nilfisk-Advance Co. Ltd.	Phone: +66 2
89 Soi Chokechai-Ruammitr	275-5630
Viphavadee-Rangsit Road	Fax: +66 2
Ladyao, Jatuchak, Bangkok 10900	691-4079
Thailand	



www.nilfisk-advance.com

© 2004 Printed in USA