



# Electronic Service Manuals

This electronic document is provided as a service to our customers. We do not create the contents of the information contained in this document. Should you have detailed questions pertaining to the information contained in this document, you may contact Michco, or the manufacturer which provided the original information in this electronic deliverable. Michco's only part in this electronic deliverable was the electronic assembly process.

You may contact Michco through the following methods:  
Phone (517) 484-9312 or (800) 331-3339 MI, OH, IN only  
2011 N. High St. -- Lansing, Michigan -- 48906  
Fax: (517) 484-9836  
Email: [CustServ@Michco.com](mailto:CustServ@Michco.com)  
Web site: [www.Michco.Com](http://www.Michco.Com)  
Parts Web site: [www.FloorMachineParts.Com](http://www.FloorMachineParts.Com)

Order Parts on Line at:  
**[www.FloorMachineParts.Com](http://www.FloorMachineParts.Com)**

Directly to Parts & Service:  
By Email: **[Shop@Michco.com](mailto:Shop@Michco.com)**  
By Fax: (517) 702-2041  
By Voice: Use numbers above.

**Serving the Cleaning Industry Since 1922**

Notice: All copyrighted material remains property of original owners, all trademarks are property of respective owners. Manuals are subject to Manufacturer's reproduction limitations. Originals or reproductions were provided by manufacturers through a request. We make no warranty as to the correctness of information provided in this document and you assume all risk.

# **Convertamatic™ 32/38LX**

---

# **Hydro-Retriever™ 320/380HD**

---

# **BA 800 / BA 1000**

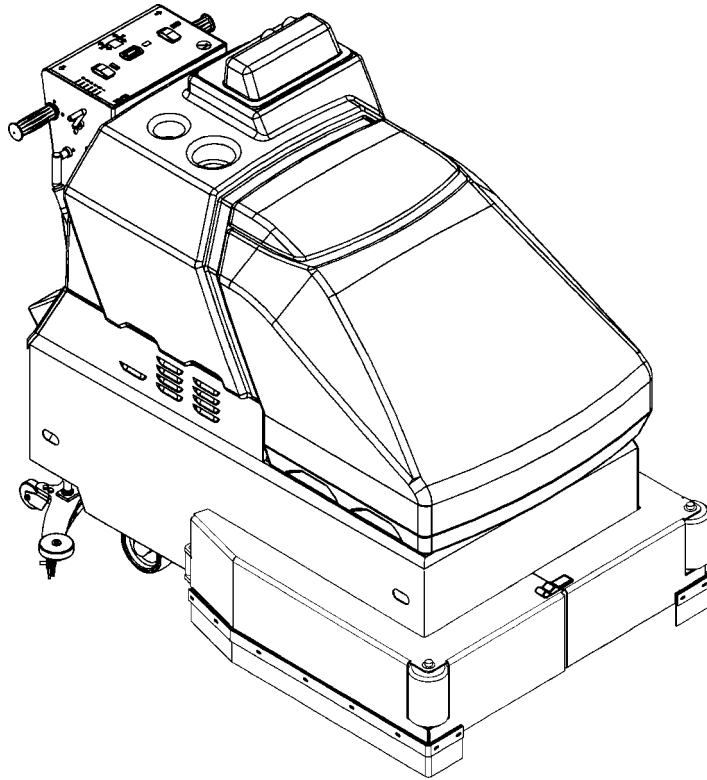

## **PARTS LIST**

**Advance MODELS 56392210(32LX), 56392220(38LX)  
56392240(320HD), 56392270(380HD)**

**Nilfisk MODELS 56392823(BA 800), 56392824(BA 1000)**

**All models covered in this manual are Obsolete.**



**Nilfisk  
Advance**

*setting standards*

95/5 revised 01/11 FORM NUMBER 56042295  
BOOK E SECTION 6.3.1

DESCRIPTION	PLAN
Control Handle System .....	E-6.3.1-3
Electrical Panel-1 .....	E-6.3.1-5
Electrical Panel-2 .....	E-6.3.1-7
Chassis System .....	E-6.3.1-9
Skirt System (32LX/320HD/BA 800) .....	E-6.3.1-11
Skirt System (38LX/380HD/BA 1000) .....	E-6.3.1-13
HD Bumper System (320HD, 380HD) .....	E-6.3.1-15
Vacuum Motor System .....	E-6.3.1-17
Drive System .....	E-6.3.1-19
Brush Lift System .....	E-6.3.1-21
Brush Drive System (32LX/320HD/BA 800) .....	E-6.3.1-23
Brush Drive System (38LX/380HD/BA 1000) .....	E-6.3.1-25
Recovery Tank System .....	E-6.3.1-27
Solution System .....	E-6.3.1-29
Squeegee Mount Assembly-1 .....	E-6.3.1-31
Squeegee Mount Assembly-2 .....	E-6.3.1-33
Squeegee Assembly-1 .....	E-6.3.1-35
Squeegee Assembly-2 .....	E-6.3.1-37
Decal System (Advance) .....	E-6.3.1-39
Decal System (Nilfisk) .....	E-6.3.1-41
Electrical System-1 .....	E-6.3.1-43
Electrical System-2 .....	E-6.3.1-45
Wiring Diagram-1 .....	E-6.3.1-47
Wiring Diagram-2 .....	E-6.3.1-49
Wiring Diagram-3 .....	E-6.3.1-51
Brush / Disc Selector Guide - BA 800 .....	E-6.3.1-52
Brush / Disc Selector Guide - BA 1000 .....	E-6.3.1-53

#### WHEN ORDERING PARTS

- \* Use the 8 digit numbers from the "Ref. No." columns in this parts list.
- \* Specify the model and serial number of the machine.
- \* Use the space below to record the model and serial number for future reference.

Model \_\_\_\_\_ Serial No. \_\_\_\_\_

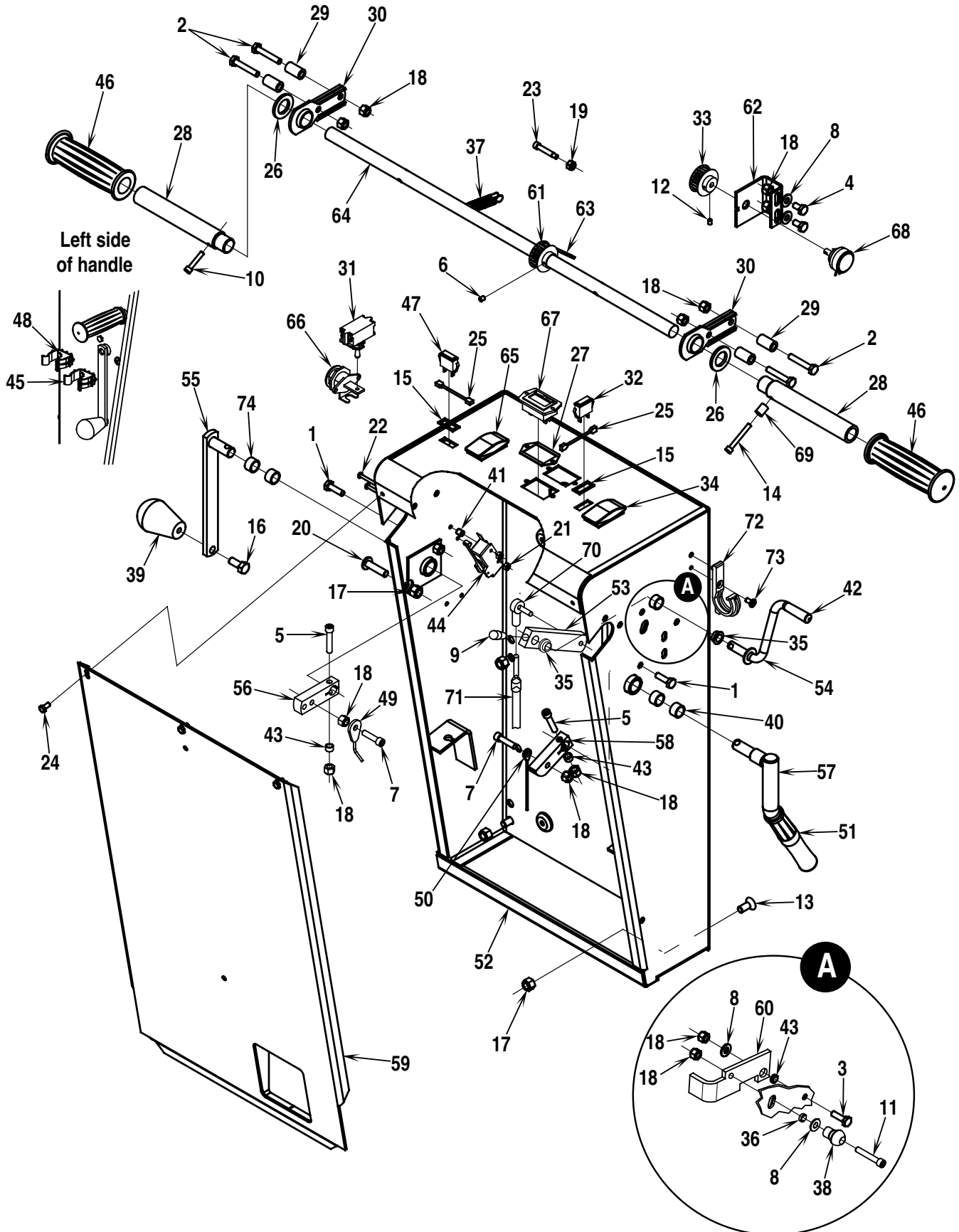

95-5	<b>CONTROL HANDLE SYSTEM</b>	<b>BOOK E</b>		
00-12	<b>32LX, 38LX / 320HD, 380HD / BA 800, BA 1000</b>	<b>E</b>	<b>6.3.1</b>	<b>3</b>

Item	Ref. No.	Qty	Description	Item	Ref. No.	Qty	Description
1	56001821	2	Scr, Hex Hd 1/4-20 x .88	42	56376486	1	Cap
2	56001833	4	Scr, Hex Hd 1/4-20 x 1.50	43	56379298	3	Bushing
3	56001836	1	Scr, Hex Hd 1/4-20 x .62	44	56324362	1	Switch, Snap, SPDT NC ( <b>Vac Motor</b> )
4	56001854	2	Scr, Hex Hd 1/4-20 x .50	45	56392171	2	Clamp, Plastic
5	56001961	2	Scr, Soc Hd 1/4-20 x 1.25	46	56388545	2	Grip, Handle
6	56002015	2	Scr, Soc Set Loc 10-24 x .25	47	56389434	1	Light, Indicator Green ( <b>Power ON</b> )
7	56002034	2	Scr, Soc Hd 1/4-20 x 1.00	48	56009135	4	Scr, Thd Form 10-24 x .62
8	56002098	4	Wsh, Flt SAE 1/4	49	56391305	1	Cable Assembly ( <b>Squeegee</b> )
9	56002115	1	Scr, Soc Hd 1/4-20 x .50	50	56391306	1	Cable Assembly ( <b>Brake</b> )
10	56002179	1	Scr, Soc Hd 10-24 x 1.00	51	56391311	1	Grip, Handle
11	56002242	1	Scr, Soc Hd 1/4-20 x 1.50	52	56391383	1	Control Panel Weld't
12	56002279	2	Scr, Soc Set Loc 8-32 x .25	53	56391494	1	Lever
13	56002395	4	Scr, Flt Phil 5/16-18 x .75	54	56391495	1	Lever Weld't ( <b>Solution Valve</b> )
14	56002454	1	Scr, Soc Hd 10-24 x 1.50	55	56324631	1	Lever Weld't ( <b>Squeegee</b> )
15	56324363	2	Gasket	56	56324632	1	Lever
16	56002667	1	Scr, Hex Hd 5/16-18 x .75	57	56391501	1	Brake Lever Weld't ( <b>before SN 1209360</b> )
17	56002701	5	Nut, Hex Nyl Loc 5/16-18	56392244	1	Brake Lever Weld't ( <b>after SN 1209359</b> )	
18	56002708	14	Nut, Hex Nyl Loc 1/4-20	58	56391504	1	Lever ( <b>before SN 1209360</b> )
19	56002768	2	Nut, Hex Nyl Loc 10-24	56392242	1	Lever ( <b>after SN 1209359</b> )	
20	56002795	1	Scr, Pan Phil 5/16-18 x 1.25	59	56392078	1	Cover Weld't
21	56002830	2	Nut, Hex Nyl Loc 6-32	60	56392091	1	Parking Brake Catch Lever
22	56003049	2	Scr, Pan Phil 6-32 x 1.25	61	56392859	1	Pulley, Cog
23	56003214	2	Scr, Soc Shd .25 x 1.25 x 10-24	62	56392718	1	Bracket, Potentiometer
24	56009012	3	Scr, Hex Thd Form 10-24 x .38	63	56392721	1	Belt, Timing
25	56389453	2	Resistor Assembly	64	56392733	1	Tube Weld't
26	56009022	2	Wsh, Flt .75 x 1.25 x .12	65	56393312	1	Switch, Rocker (Brush)
27	56392845	1	Gasket	66	56393325	1	Bracket, Keylock
28	56261064	2	Tube	*	56393415	1	Replacement Key
29	56261066	4	Bushing	67	56393717	1	Fuel Guage, Battery
30	56261097	2	Bearing	68	56454740	1	Potentiometer, 5K
31	56301636	1	Switch, Toggle ( <b>Main switch</b> )	69	56475411	1	Bushing, .25 x .37 x .48
32	56324028	1	Light, Indicator Blue ( <b>Solution ON</b> )	70	56488290	1	Rod End
33	56324513	1	Pulley, Cog	71	56376320	1	Cable (Solution Valve)
34	56324272	1	Switch, Rocker ( <b>Solution Switch</b> ) <b>TSB 663</b>	72	56324349	1	Hook
35	56324505	2	Bearing, Flange	73	56009030	1	Scr, Thd Form #10-24 x .38
36	56328758	1	Bushing	74	56366633	2	Bearing, Sleeve ( <b>before SN 1230124</b> )
37	56358560	2	Spring				
38	56362426	1	Knob, Plastic				
39	56364527	1	Knob				
40	56366633	2	Bearing, Sleeve ( <b>before SN 1209360</b> )				
41	56369004	2	Bushing				

\* = Not Shown

### BA 800, BA 1000 Before SN 1081111

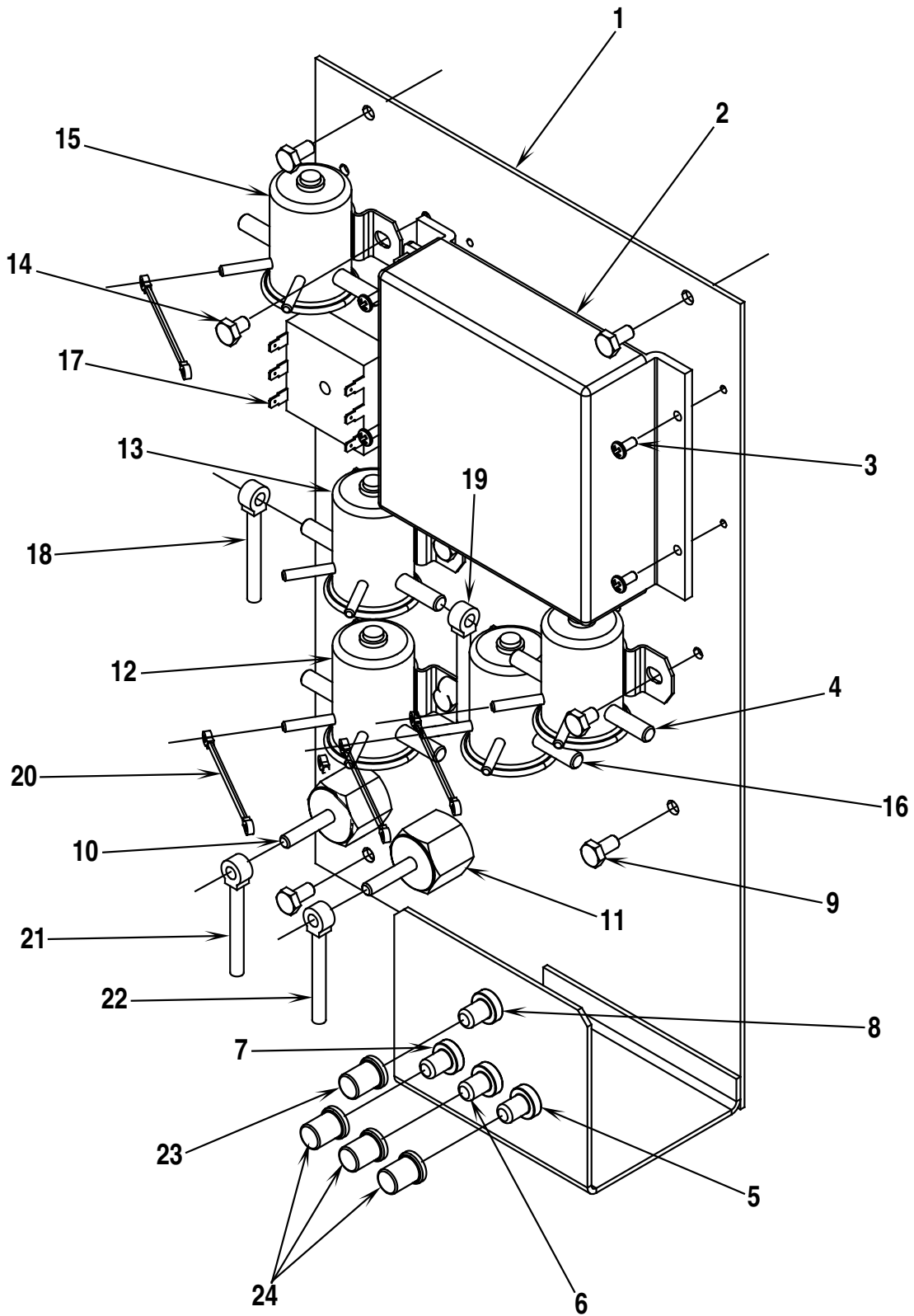

95-5	<b>ELECTRICAL PANEL-1</b>	<b>BOOK E</b>		
00-12	<b>32LX, 38LX / 320HD, 380HD / BA 800, BA 1000</b>	<b>E</b>	<b>6.3.1</b>	<b>5</b>

Item	Ref. No.	Qty	Description
1	56392678	1	Panel Weld't
2	56391210	1	Control, Speed
3	56002523	4	Scr, Pan Phil Thd Form 8-32 x .38
4	56388534	1	Solenoid, 36V ( <b>Brush Down</b> )
5	56469788	1	Circuit Breaker, 25 Amp ( <b>Vac Motor</b> )
6	56469788	1	Circuit Breaker, 25 Amp ( <b>Drive Motor</b> )
7	56387328	1	Circuit Breaker, 5 Amp ( <b>Control Circuit</b> )
8	56454429	1	Circuit Breaker, 70 Amp ( <b>Brush Motor</b> )
9	56009033	4	Scr, Hex Thd Form 1/4-20 x .50
10	56454376	2	Stud, 1/4-20
11	56469858	2	Standoff, Insulated
12	56395452	1	Solenoid, 36V ( <b>Vac Motor</b> )
13	56395452	1	Solenoid, 36V ( <b>Brush Motor</b> )
14	56009019	10	Scr, Hex Thd Form 1/4-20 x .38
15	56395452	1	Solenoid, 36V ( <b>Drive Motor</b> )
16	56388534	1	Solenoid, 36V ( <b>Brush Up</b> )
17	56391357	1	Time Delay, 1.5 SEC
18	56391159	1	Cable Assembly
19	56376406	1	Cable Assembly
20	56389265	4	Diode Assembly
21	56391160	1	Cable Assembly
22	56393379	1	Cable Assembly
23	56459369	1	Boot, Reset Button
24	56459367	3	Boot, Reset Button
*	56392154	1	Wiring Harness, Main

\* = Not Shown

**BA 800, BA 1000 After SN 1081110  
All 32LX, 38LX / 320HD, 380HD**

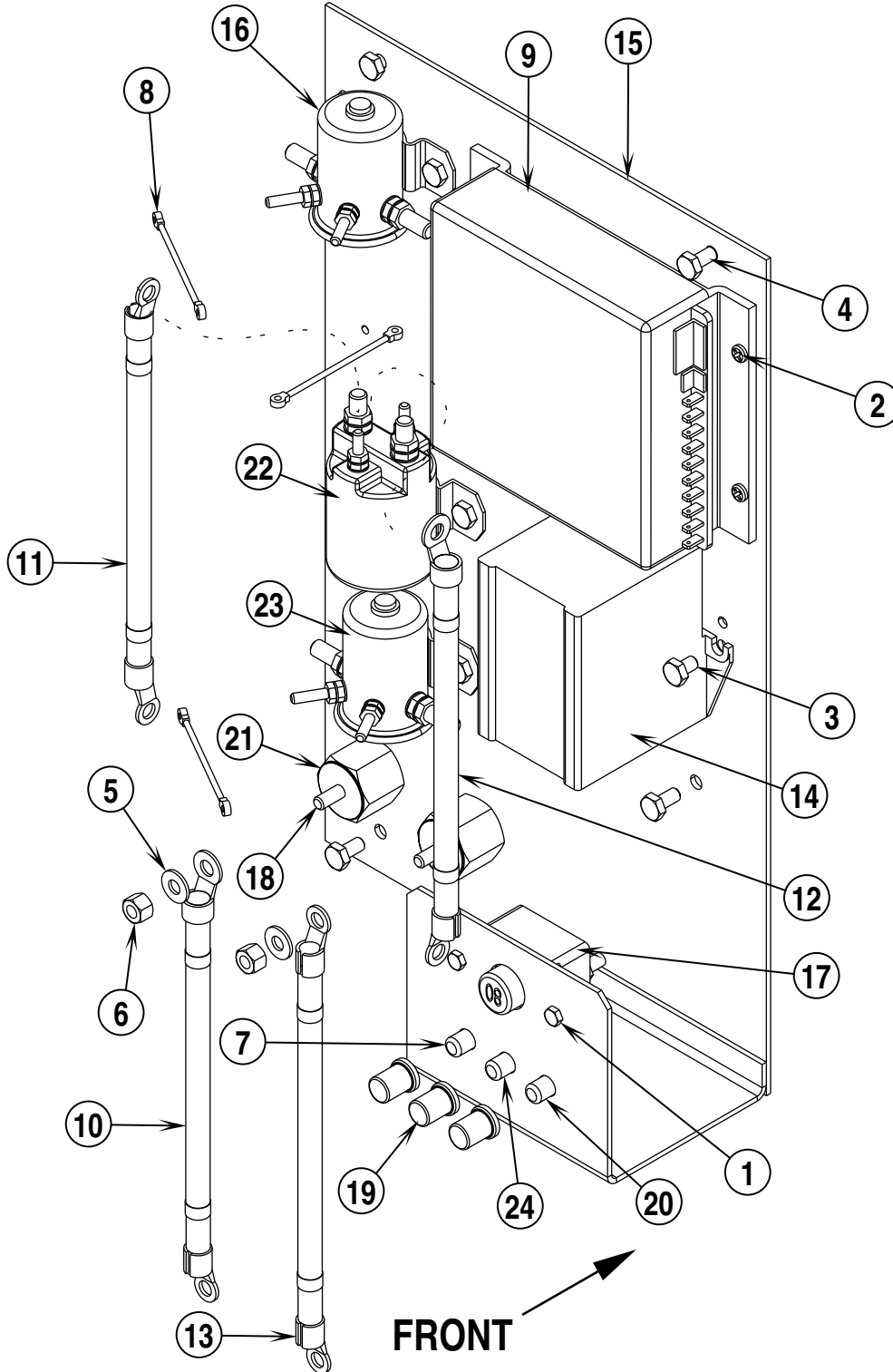

95-5	<b>ELECTRICAL PANEL-2</b>	<b>BOOK E</b>		
00-12	<b>32LX, 38LX / 320HD, 380HD / BA 800, BA 1000</b>	<b>E</b>	<b>6.3.1</b>	<b>7</b>

Item	Ref. No.	Qty	Description
1	56002425	2	Scr, Hex Hd 10-24 x .88
2	56002523	4	Scr, Pan Phil Thd Form 8-32 x .38
3	56009019	8	Scr, Hex Thd Form 1/4-20 x .38
4	56009033	4	Scr, Hex Thd Form 1/4-20 x .50
5	56009064	2	Wsh, Int Shprf 1/4
6	56009179	2	Nut, Hex Machine 1/4-20
7	56387328	1	Circuit Breaker, 5 Amp ( <b>Control Circuit</b> )
8	56389265	3	Diode Assembly
9	56391210	1	Control, Speed
10	56391385	1	4 AWG No. 4 Cable Assembly
11	56391386	1	4 AWG No. 3 Cable Assembly
12	56391387	1	4 AWG No. 27 Cable Assembly
13	56391388	1	4 AWG No. 2 Cable Assembly
14	56392173	1	Actuator Control Module ( <b>gearbox</b> )
15	56392678	1	Panel, Electrical
16	56395452	1	Solenoid, 36V ( <b>Drive Motor</b> )
17	56409230	1	Circuit Breaker, 80 Amp ( <b>Brush Motor</b> )
18	56454376	2	Stud, 1/4-20
19	56459367	3	Boot, Reset Button
20	56469788	1	Circuit Breaker, 25 Amp ( <b>Vacuum Motor</b> )
21	56469858	2	Standoff, Insulated
22	56395450	1	Solenoid, 36V ( <b>Brush Motor</b> )
23	56395452	1	Solenoid, 36V ( <b>Vacuum Motor</b> )
24	56469788	1	Circuit Breaker, 25 Amp ( <b>Drive Motor</b> )

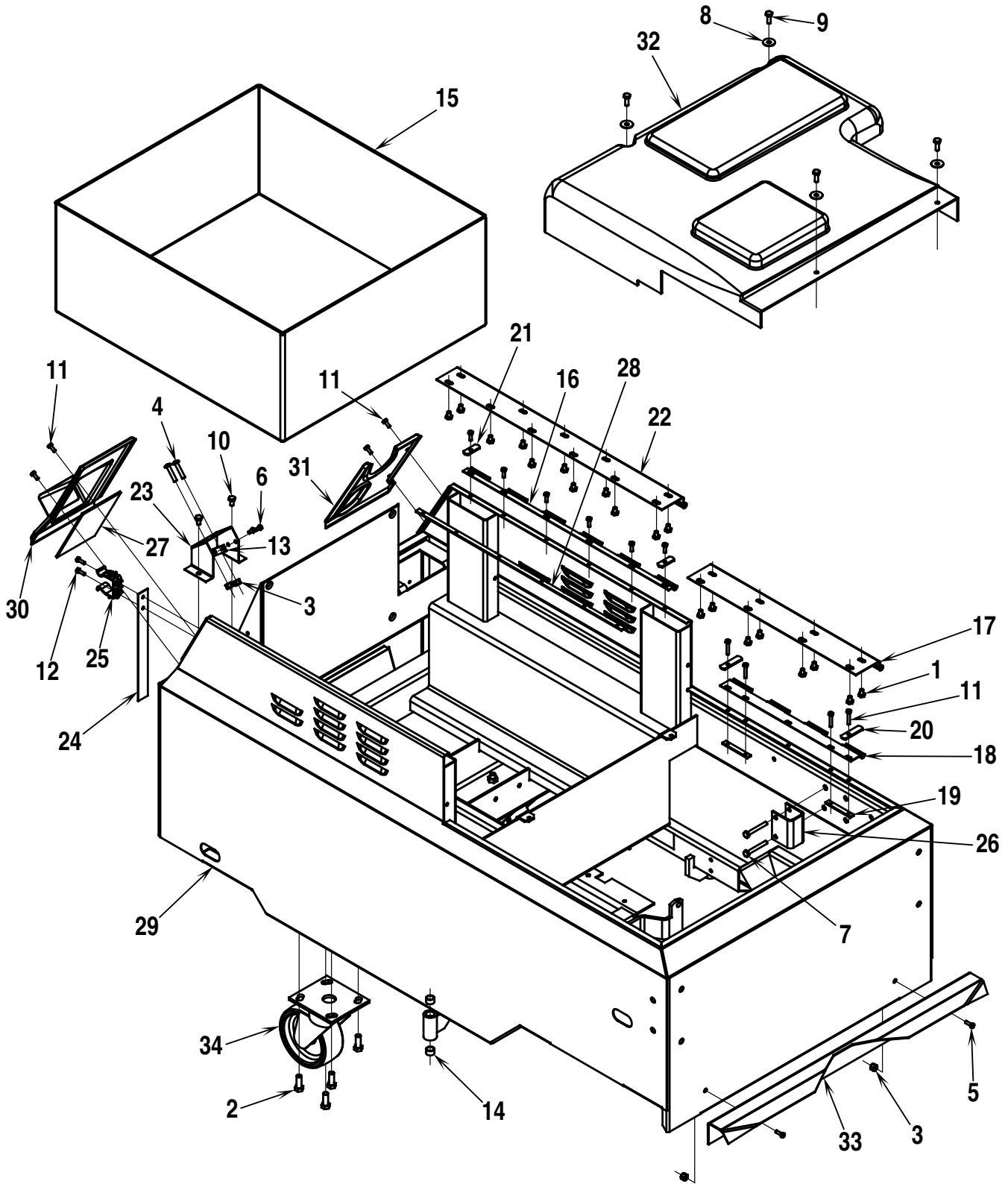

95-5	<b>CHASSIS SYSTEM</b>	<b>BOOK E</b>		
00-12	<b>32LX, 38LX / 320HD, 380HD / BA 800, BA 1000</b>	<b>E</b>	<b>6.3.1</b>	<b>9</b>

Item	Ref. No.	Qty	Description
1	56001861	19	Scr, Hex Hd 1/4-20 x .38
2	56002256	8	Scr, Hex Type F 3/8-16 x 1.00
3	56002708	4	Nut, Hex Nyl Loc 1/4-20
4	56002825	2	Scr, Pan Phil 1/4-20 x 1.25
5	56002829	2	Scr, Hex Hd 10-24 x .62
6	56002926	2	Scr, Hex Hd Loc 10-24 x .38
7	56003117	2	Scr, Hex Hd Loc 1/4-20 x 2.00
8	56009002	4	Wsh, Flt .26 x .90 x .06
9	56009018	4	Scr, Hex Thd Form 1/4-20 x .75
10	56009033	2	Scr, Hex Thd Form 1/4-20 x .50
11	56009039	17	Scr, Hex Thd Form 10-24 x .50
12	56009135	2	Scr, Hex Thd Form 10-24 x .62
13	56324310	1	Nut Plate
14	56366633	4	Bearing, Sleeve
15	56391248	1	Tray, Battery
16	56391181	1	Hinge, Recovery
17	56391234	1	Hinge, Solution Tank
18	56391237	1	Hinge, Solution
19	56391239	2	Nut Plate
20	56391240	2	Clip, Hinge
21	56391260	2	Clip, Hinge
22	56391381	1	Hinge, Recovery Tank
23	56392164	1	Bracket
24	56392167	1	Strap, Web
25	56392171	1	Clamp, Plastic
26	56392186	1	Bracket, Valve
27	56392195	1	Guard
28	56392676	1	Nut, Plate
29	56392835	1	Chassis Weld't
30	56392846	1	Panel, Rear Right
31	56392847	1	Panel, Rear Left
32	56392848	1	Cover
33	56393448	1	Support, Front Skirt
34	56440450	2	Caster, Swivel
	56503007	A/R	Wheel (for caster, swivel)
*	56300542	1	Clamp, Cord

\* = Not Shown



95-5	<b>SKIRT SYSTEM (32LX/320HD/BA 800)</b>	<b>BOOK E</b>		
00-12	<b>32LX, 38LX / 320HD, 380HD / BA 800, BA 1000</b>	<b>E</b>	<b>6.3.1</b>	<b>11</b>

Item	Ref. No.	Qty	Description
1	56009013	4	Scr, Pan Phil Thd Form-Blk 6-32 x .38
2	56009033	4	Scr, Hex Thd Form 1/4-20 x .50
3	56009082	22	Scr, Pan Phil Thd Form-Blk 10-24 x .50
4	56009097	4	Nut, Push Cap 1/2
5	56360147	2	Pin
6	56392099	2	Retainer
7	56392100	2	Skirt
8	56392102	2	Roller
9	56392854	2	Retainer
10	56392855	2	Skirt
11	56392856	2	Skirt Weld't
12	56393372	2	Rod
13	56393442	1	Skirt, Left Weld't
14	56393664	1	Skirt, Right Weld't
15	56462316	1	Latch

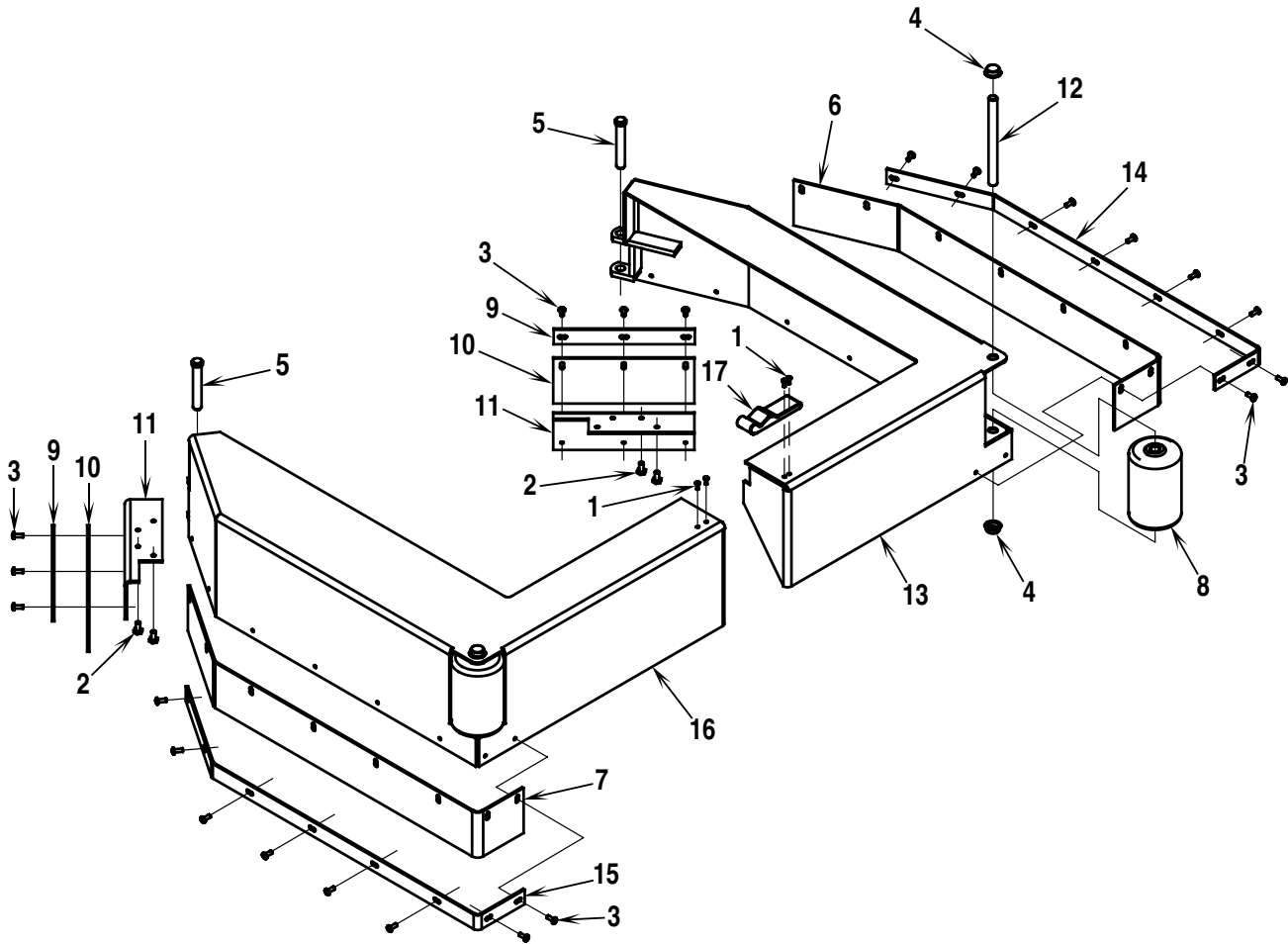

95-5	<b>SKIRT SYSTEM (38LX/380HD/BA 1000)</b>	<b>BOOK E</b>		
00-12	<b>32LX, 38LX / 320HD, 380HD / BA 800, BA 1000</b>	<b>E</b>	<b>6.3.1</b>	<b>13</b>

Item	Ref. No.	Qty	Description
1	56009013	4	Scr, Pan Phil Thd Form-Blk 6-32 x .38
2	56009033	4	Scr, Hex Thd Form 1/4-20 x .50
3	56009082	22	Scr, Pan Phil Thd Form-Blk 10-24 x .50
4	56009097	4	Nut, Push Cap 1/2
5	56360147	2	Pin
6	56393486	1	Skirt, Right
7	56393487	1	Skirt, Left
8	56392102	2	Roller
9	56392854	2	Retainer
10	56392855	2	Skirt
11	56392856	2	Skirt Weld't
12	56393372	2	Rod
13	56393477	1	Skirt, Left Weld't
14	56393485	1	Retainer, Left Skirt
15	56393484	1	Retainer, Right Skirt
16	56393476	1	Skirt, Right Weld't
17	56462316	1	Latch

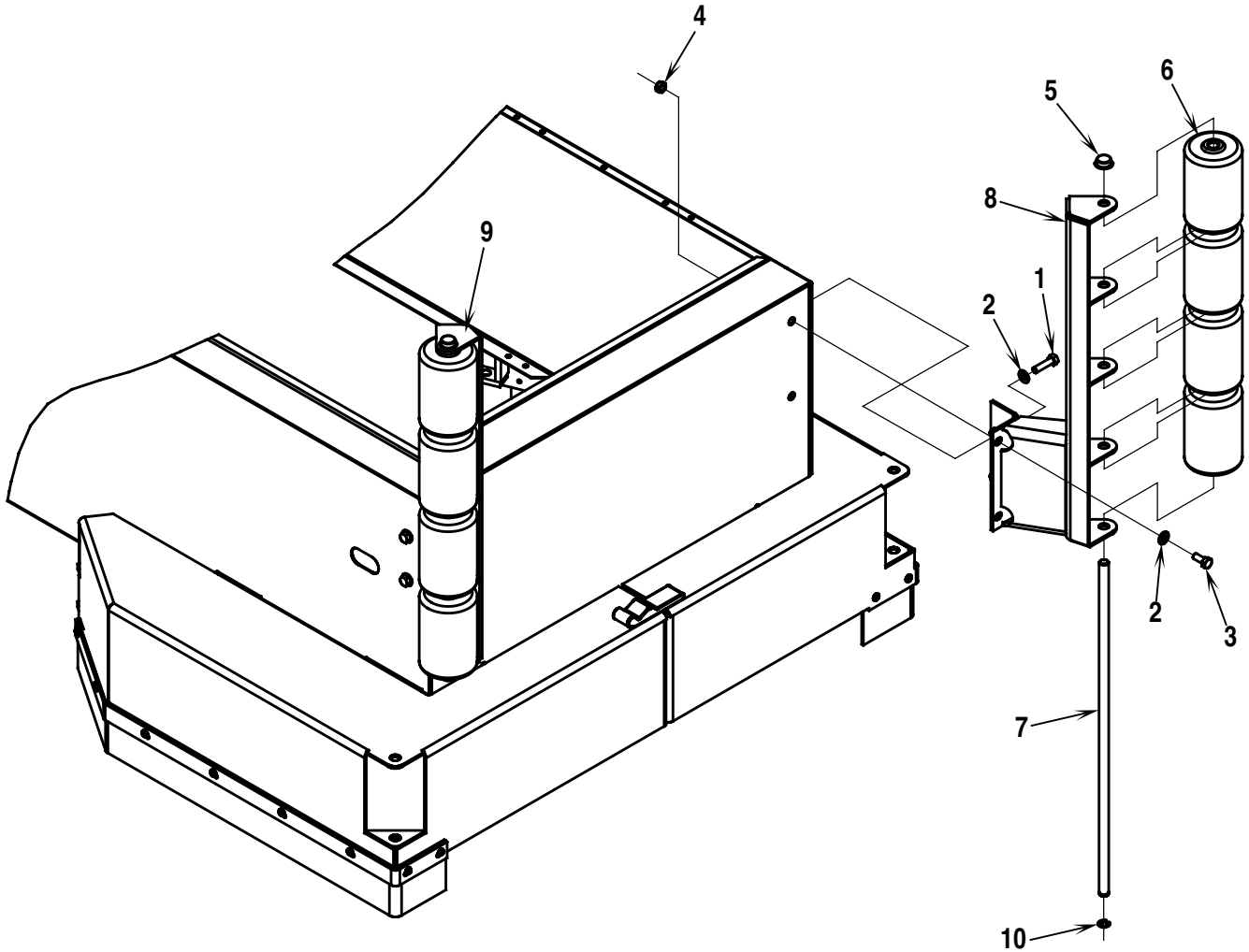

95-5	<b>HD BUMPER SYSTEM (320HD, 380HD)</b>	<b>BOOK E</b>		
00-12	<b>32LX, 38LX / 320HD, 380HD / BA 800, BA 1000</b>	<b>E</b>	<b>6.3.1</b>	<b>15</b>

Item	Ref. No.	Qty	Description
1	56001834	2	Scr, Hex Hd 5/16-18 x 1.25
2	56001939	8	Wsh, Flt SAE 5/16
3	56002667	6	Scr, Hex Hd 5/16-18 x .75
4	56002826	8	Nut, Hex Nyl Loc-Thin 5/16-18
5	56009097	2	Nut, Push Cap 1/2
6	56392102	8	Roller
7	56392809	2	Rod
8	56392813	1	Left Hand Bumper Weld't
9	56392814	1	Right Hand Bumper Weld't
10	56468834	2	Ring, Retaining

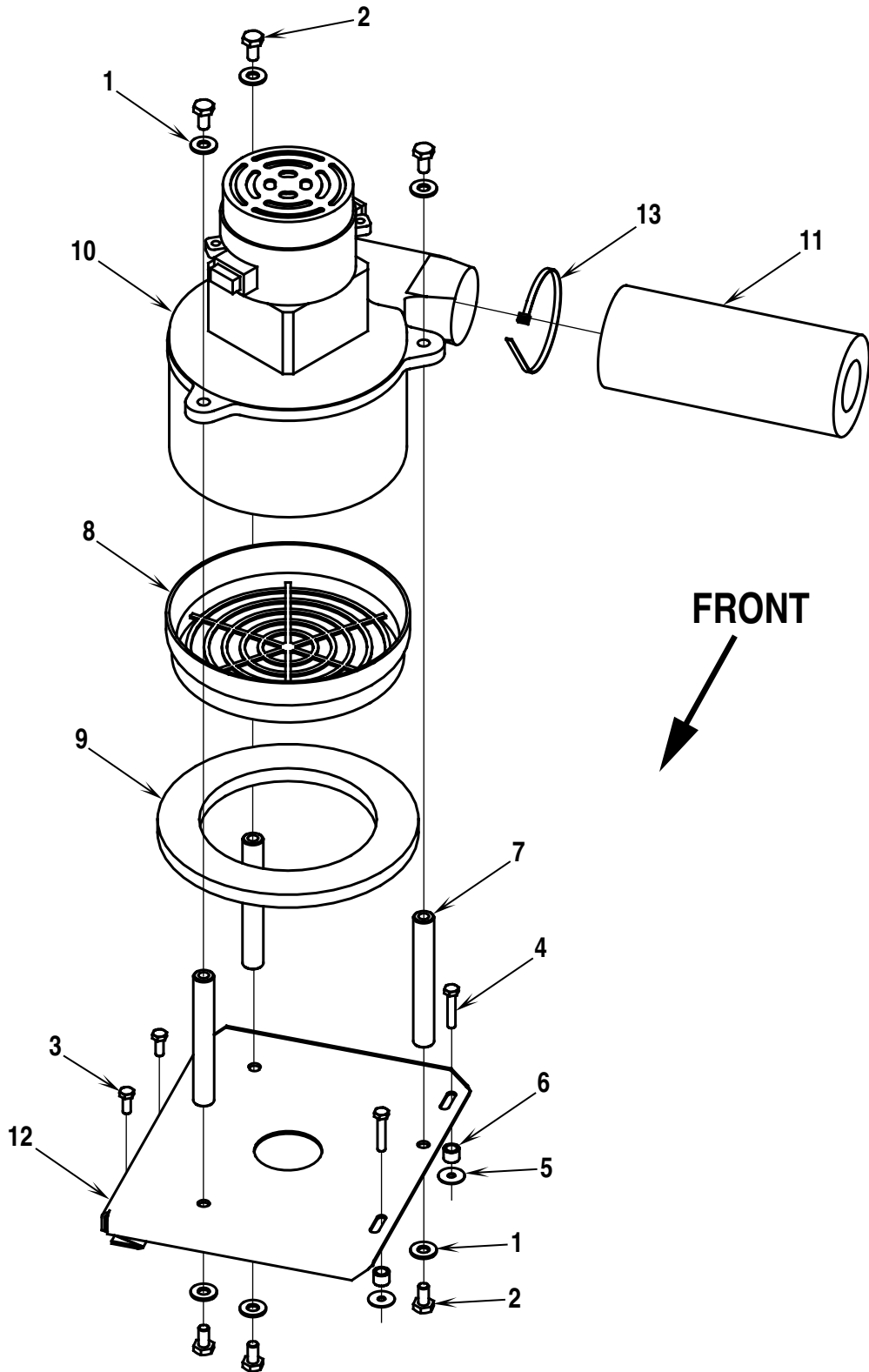

Item	Ref. No.	Qty	Description
1	56002098	6	Wsh, Flt SAE 1/4
2	56003039	6	Scr, Hex Hd Loc 1/4-20 x .50
3	56009039	2	Scr, Hex Thd Form 10-24 x .50
4	56009176	2	Scr, Hex Thd Form 10-24 x 1.00
5	56200190	2	Washer, Fibre
6	56368989	2	Bushing
7	56377474	3	Stand-off
8	56384898	1	Filter
9	56385437	1	Gasket
10	56391208	1	Vac Motor, 36V
*	56377001	1	Carbon Brushes for Vac Motor
11	56391807	1	Foam, Accoustical
12	56392789	1	Mount, Vacuum Motor
13	56477616	1	Cable Tie

\* = Not Shown

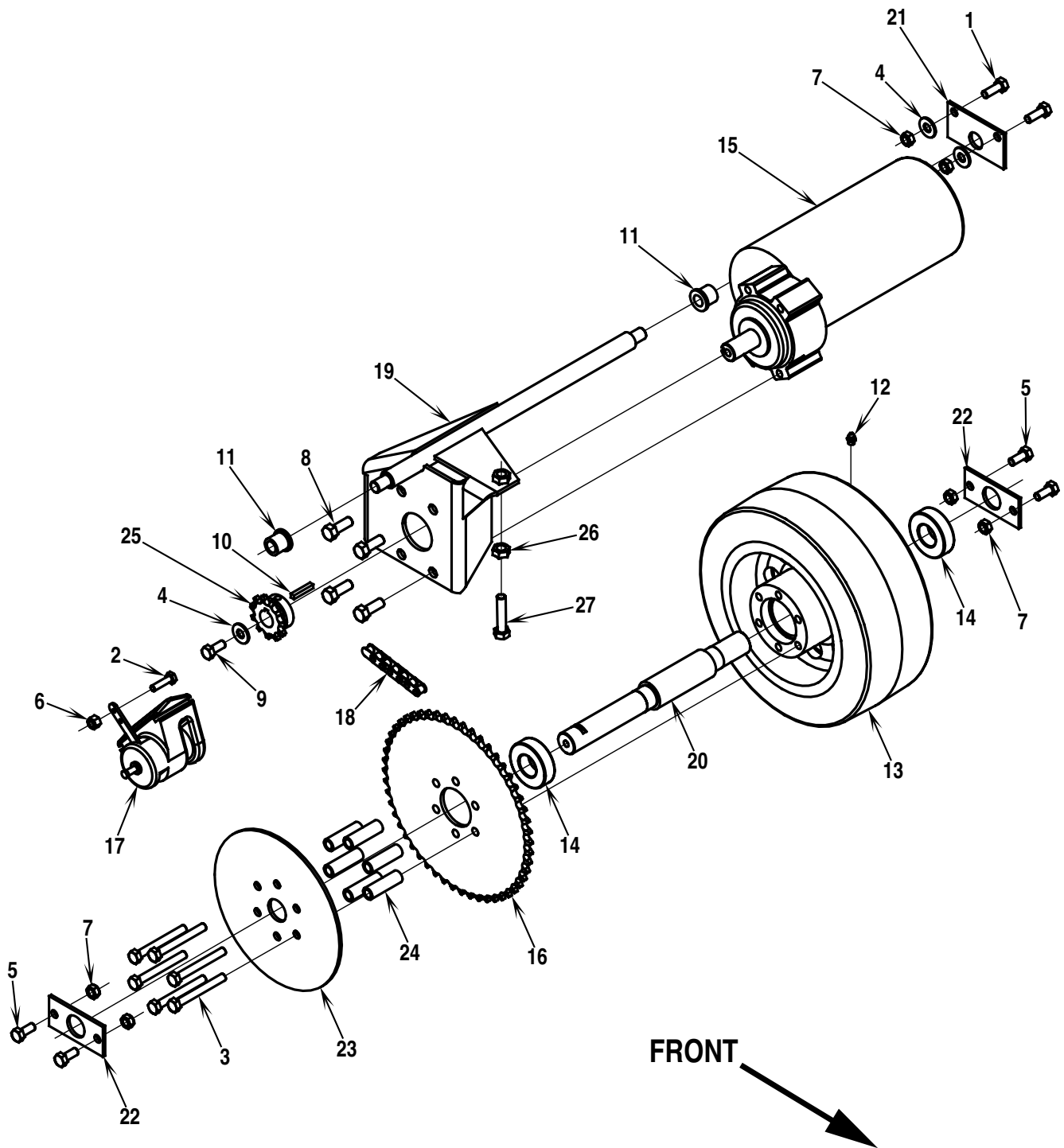

95-5	<b>DRIVE SYSTEM</b>	<b>BOOK E</b>		
00-12	<b>32LX, 38LX / 320HD, 380HD / BA 800, BA 1000</b>	<b>E</b>	<b>6.3.1</b>	<b>19</b>

Item	Ref. No.	Qty	Description
1	56002037	2	Scr, Hex Hd 5/16-18 x .88
2	56002093	1	Scr, Hex Hd 1/4-20 x 1.00
3	56002203	6	Scr, Hex Hd 5/16-18 x 2.75
4	56002220	3	Wsh, Flt Std 5/16
5	56002667	4	Scr, Hex Hd 5/16-18 x .75
6	56002708	1	Nut, Hex Nyl Loc 1/4-20
7	56002826	6	Nut, Hex Nyl Loc-Thin 5/16-18
8	56002947	4	Scr, Hex Hd Loc 3/8-16 x 1.00
9	56002956	1	Scr, Hex Hd Loc 5/16-18 x .75
10	56003240	1	Key, Sq .19 x 1.12
11	56111503	2	Bearing, Flange
12	56344362	1	Fitting Lube 1/4-28
13	56376628	1	Wheel 10.00 x 4.00
14	56378380	2	Bearing, Ball
15	56388585	1	Drive Motor
*	56388586	1	Carbon Brushes for Drive Motor
16	56388700	1	Sprocket
17	56391301	1	Brake
18	56391310	1	Chain, Roller
19	56391530	1	Motor Bracket Weld't
20	56391534	1	Axle
21	56391535	1	Pillow Block
22	56391536	2	Pillow Block
23	56391537	1	Disc, Brake
24	56391539	6	Spacer
25	56471148	1	Sprocket
26	56001894	1	Nut, Hex Lock 3/8-16
27	56002470	1	Scr, Hex 3/8-16 x 2.00

\* = Not Shown

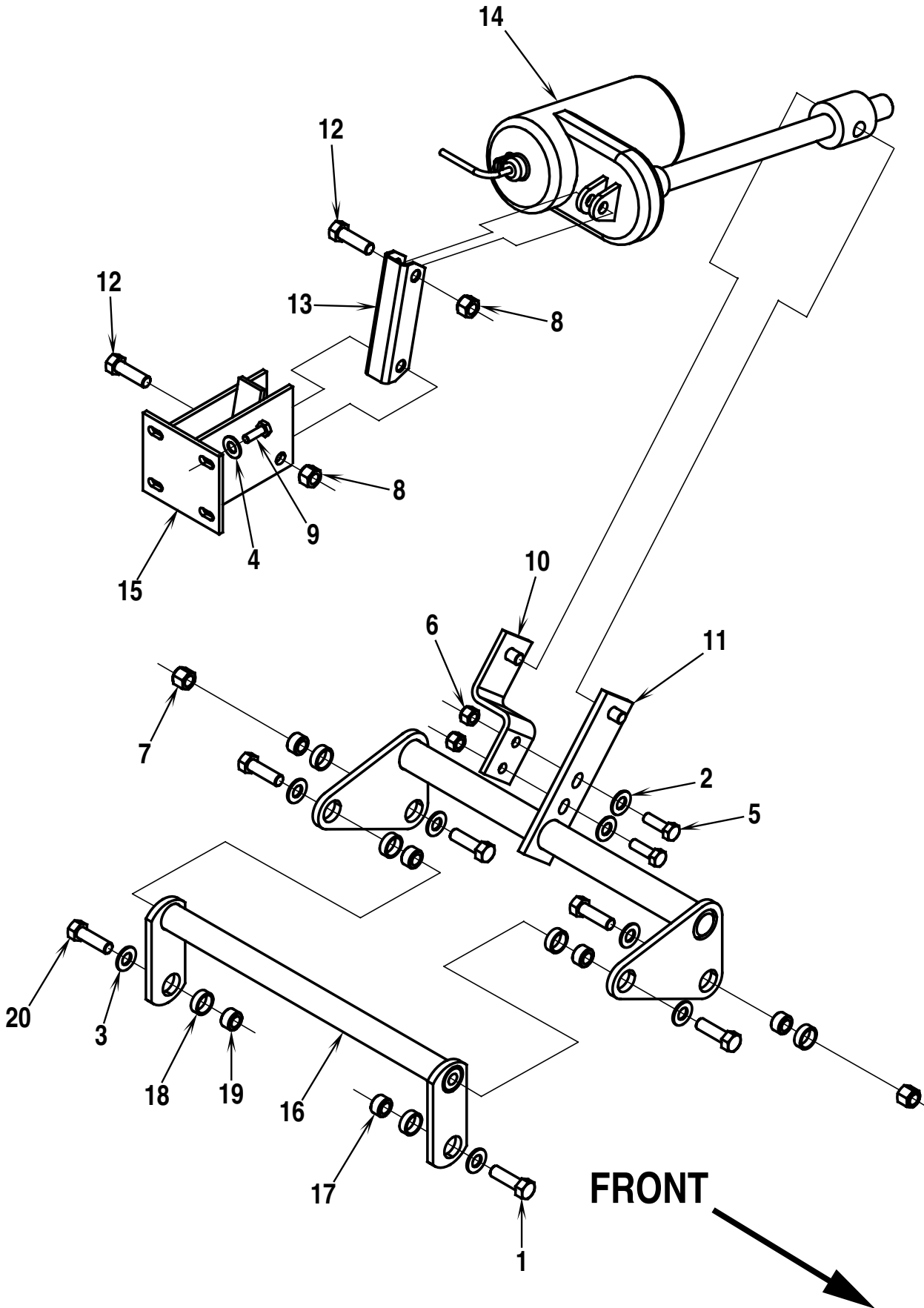

95-5	<b>BRUSH LIFT SYSTEM</b>	<b>BOOK E</b>		
00-12	<b>32LX, 38LX / 320HD, 380HD / BA 800, BA 1000</b>	<b>E</b>	<b>6.3.1</b>	<b>21</b>

Item	Ref. No.	Qty	Description
1	56001858	5	Scr, Hex Hd 3/8-16 x 1.25
2	56001939	2	Wsh, Flt SAE 5/16
3	56002063	6	Wsh, Flt SAE 3/8
4	56002098	4	Wsh, Flt SAE 1/4
5	56002221	2	Scr, Hex Hd 5/16-18 x 1.00
6	56002701	2	Nut, Hex Nyl Loc 5/16-18
7	56002769	2	Nut, Hex Nyl Loc 3/8-16
8	56002841	2	Nut, Hex Nyl Loc-thin 3/8-16 <b>NOTE 1</b>
9	56009018	4	Scr, Hex Thd Form 1/4-20 x .75
10	56100019	1	Half Yoke Weld't
11	56100023	1	Torsion Bar Weld't
12	56002684	2	Screw, Hex Hd 3/8-16x1.75
13	56391626	1	Arm, Swing
14	56391627	1	Actuator, Motor
*	56388520	1	Nut, Plastic for Actuator
*	56470431	1	Carbon Brush Kit for Actuator
*	56393790	A/R	Switch, Limit for Actuator
15	56392394	1	Actuator Mount Weld't
16	56392441	1	Torsion Bar Weld't
17	56392449	2	Bushing
18	56478781	6	Bearing, Sleeve
19	56392035	2	Bushing
20	56002947	1	Screw, Hex Hd Loc 3/8-16x1.00

\* = Not Shown

**NOTE 1:** Tighten nut until threads on the end of the screw are flush with nut. **Caution!** Do not overtighten.

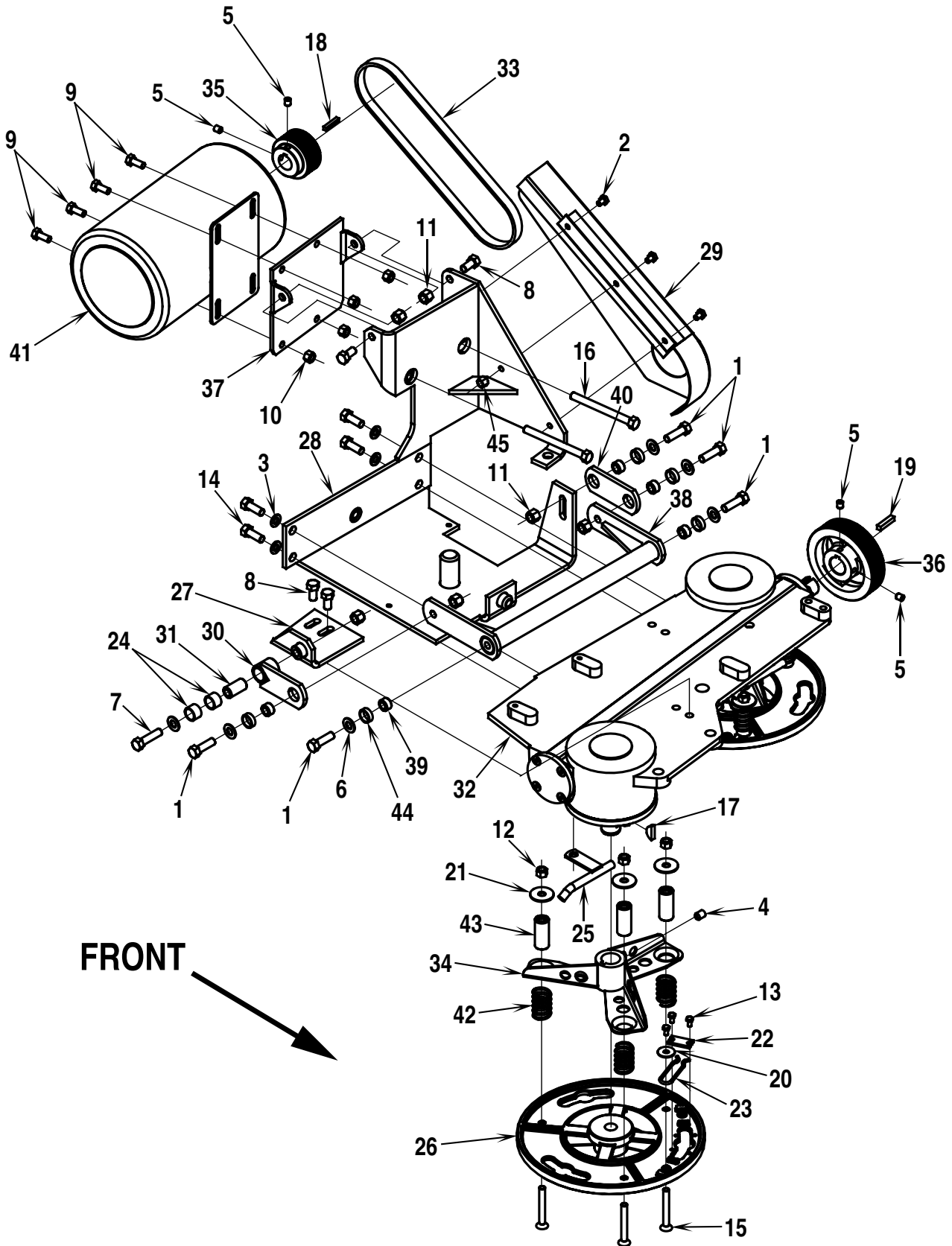

95-5	<b>BRUSH DRIVE SYSTEM (32LX/320HD/BA 800)</b>	<b>BOOK E</b>		
00-12	<b>32LX, 38LX / 320HD, 380HD / BA 800, BA 1000</b>	<b>E</b>	<b>6.3.1</b>	<b>23</b>

Item	Ref. No.	Qty	Description	Item	Ref. No.	Qty	Description
1	56001858	5	Scr, Hex Hd 3/8-16 x 1.25	40	56392450	1	Arm, Linkage
2	56001861	3	Scr, Hex Hd 1/4-20 x .38	41	56392489	1	Motor, 2.25HP 36V
3	56001939	4	Wsh, Flt SAE 5/16				<b>(BA800 before SN1076225)</b>
4	56001958	2	Scr, Soc Set Loc 3/8-16 x .50	*	56448729	1	Carbon Brush for 56392489
5	56002021	4	Scr, Soc Set Loc 5/16-18 x .38		56409825	1	Motor, 3HP 36V
6	56002063	6	Wsh, Flt SAE 3/8				<b>(BA800 after SN1076224, all 32LX/320HD)</b>
7	56002095	1	Scr, Hex Hd 3/8-16 x 1.50	*	56409739	4	Carbon Brush for 56409825
8	56002127	4	Scr, Hex Hd 3/8-16 x .75	*	56409738	1	Brush Spring for 56409825
9	56002667	4	Scr, Hex Hd 5/16-18 x .75				<b>(4 required)</b>
10	56002701	4	Nut, Hex Nyl Loc 5/16-18	*	56409828	1	Wsh, Bearing Spring
11	56002769	6	Nut, Hex Nyl Loc 3/8-16	*	56409829	1	Bearing
12	56002856	6	Nut, Hex Nyl Loc SS 5/16-18	*	56409830	1	Bearing
13	56002879	6	Scr, Hex Hd SS 10-24 x .38	*	56409831	1	CompleteCommutator
14	56002947	4	Scr, Hex Hd Loc 3/8-16 x 1.00				Cover Assy.
15	56002965	6	Scr, Flt Phil SS 5/16-18 x 2.50	*	56409832	1	Commutator Cover
16	56002977	2	Scr, Hex Thd to Hd 3/8-16 x 4.00	*	56409833	1	Complete Brush Ring Assy.
17	56003231	2	Key, Wdf .88 x .25	*	56409834	1	Pulley Cover
18	56003240	1	Key, Sq .19 x 1.12	*	56409835	1	Complete Stator Assy.
19	56003245	1	Key, Sq .25 x 1.19				W/Baffle
20	56009002	2	Wsh, Flt .26 x .90 x .06	*	56409836	1	Complete Armature Assy.
21	56009094	6	Wsh, Flt SS .38 x 1.25 x .07	42	56392513	6	Spring, Compression
22	56366455	2	Plate, Stop	43	56392530	6	Spacer
23	56366463	2	Spring Retainer	44	56478781	5	Bearing, Sleeve
24	56367168	2	Bearing, Sleeve	45	56002840	3	Nut, Hex Nyl Loc-Thin 1/4-20
25	56391604	2	Pipe Weld't				
26	56391611	2	Holder Casting, Brush	**	56505780	2	Short Trim Pad Holder
27	56392029	1	Linkage Arm Weld't	**	56505781	2	Magna Grit Brush
28	56392109	1	Motor Mount Weld't	**	56505782	2	Dyna Grit Brush
29	56392043	1	Belt Guard Weld't	**	56505783	2	AgLite Grit Brush
30	56392045	1	Linkage Arm Weld't	**	56505784	2	Prolene Brush
31	56392046	1	Bushing	**	56505785	2	ProLite Brush
32	56392090	1	Gearbox Assembly	**	56505786	2	Union Mix Brush
33	56392292	1	Belt, Poly-V	**	56505787	2	MidGrit Brush
			<b>(BA800 before SN1076225)</b>	**	56505788	2	MidLite Grit Brush
	56392497	1	Belt, Poly-V				
			<b>(BA800 after SN1076224, all 32LX/320HD)</b>				
34	56392396	2	Drive Adaptor Weld't				
35	56392399	1	Sheave, Poly-V				
			<b>(BA800 before SN1076225)</b>				
	56392213	1	Sheave, Poly-V				
			<b>(BA800 after SN1076224, all 32LX/320HD)</b>				
36	56392400	1	Sheave, Poly-V				
37	56392424	1	Mount, Gearbox Motor				
38	56392431	1	Torsion Bar Weld't				
39	56392449	5	Bushing				

\* = Not Shown  
\*\* = Optional, Not Included

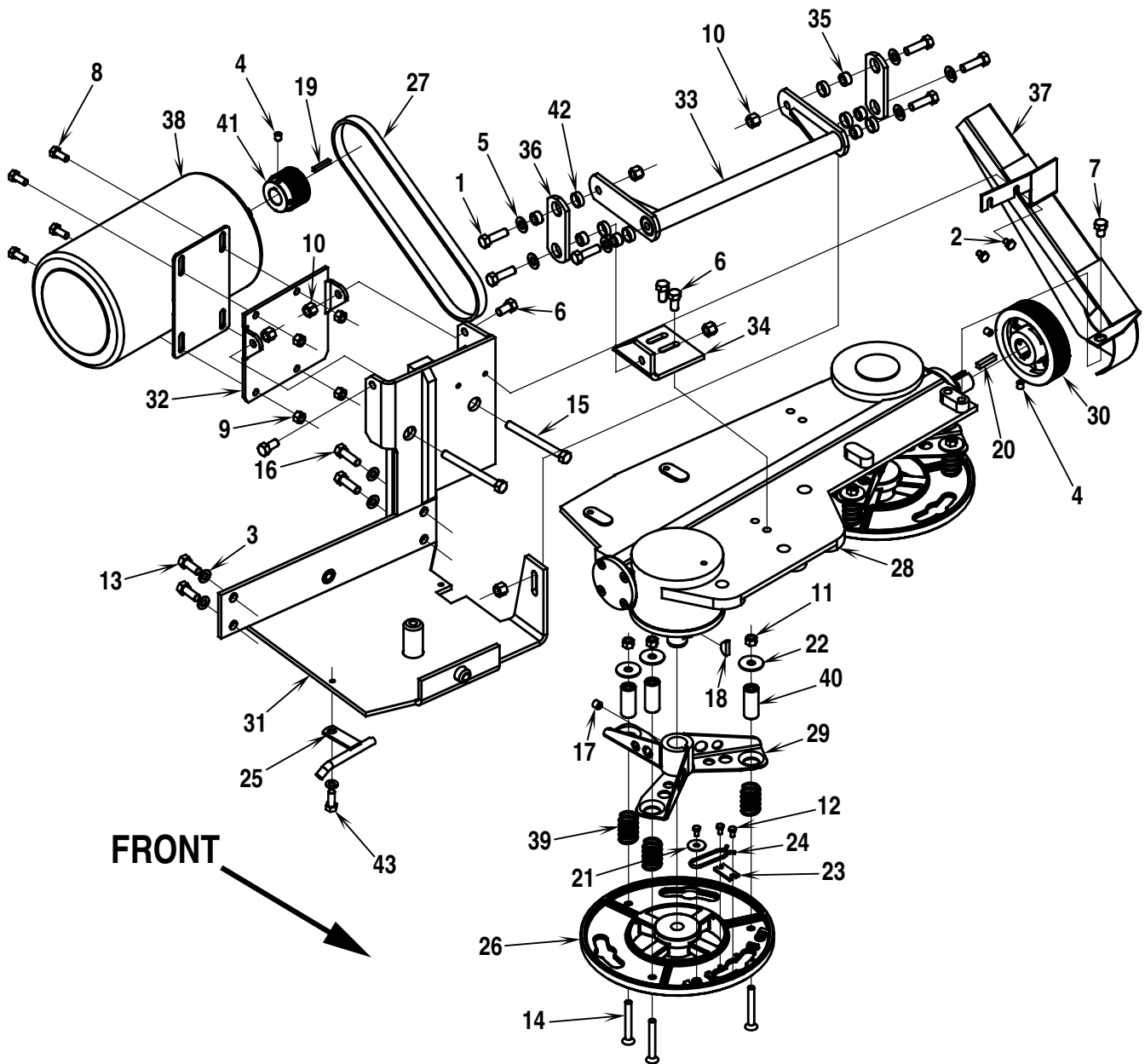

95-5	<b>BRUSH DRIVE SYSTEM (38LX/380HD/BA 1000)</b>	<b>BOOK E</b>		
00-12	<b>32LX, 38LX / 320HD, 380HD / BA 800, BA 1000</b>	<b>E</b>	<b>6.3.1</b>	<b>25</b>

Item	Ref. No.	Qty	Description	Item	Ref. No.	Qty	Description
1	56001858	4	Scr, Hex Hd 3/8-16 x 1.25	35	56392449	6	Bushing
2	56009019	2	Scr, Hex Thd Form 1/4-20 x .38	36	56392450	2	Arm, Linkage
3	56001939	10	Wsh, Flt SAE 5/16	37	56392488	1	Belt Guard Weld't
4	56002021	4	Scr, Soc Set Loc 5/16-18 x .38	38	56392489	1	Motor, 2.25HP 36V
5	56002063	9	Wsh, Flt SAE 3/8				<b>(BA1000 before SN1078241)</b>
6	56002127	4	Scr, Hex Hd 3/8-16 x .75	*	56448729	1	Carbon Brush for 56392489
7	56003023	1	Scr, Hex Hd Loc 3/8-16 x .50		56409825	1	Motor, 3HP 36V
8	56002667	4	Scr, Hex Hd 5/16-18 x .75				<b>(BA1000 after SN1078240, all 38LX/380HD)</b>
9	56002701	4	Nut, Hex Nyl Loc 5/16-18	*	56409739	4	Carbon Brush for 56409825
10	56002769	6	Nut, Hex Nyl Loc 3/8-16	*	56409738	1	Brush Spring for 56409825
11	56002856	6	Nut, Hex Nyl Loc SS 5/16-18				<b>(4 required)</b>
12	56009012	6	Scr, Hex Thd Form 10-24 x .38	*	56409828	1	Wsh, Bearing Spring
13	56002947	2	Scr, Hex Hd Loc 3/8-16 x 1.00	*	56409829	1	Bearing
14	56002965	6	Scr, Flt Phil SS 5/16-18 x 2.50	*	56409830	1	Bearing
15	56002977	2	Scr, Hex Thd to Hd 3/8-16 x 4.00	*	56409831	1	Complete
16	56003029	2	Scr, Hex Hd Loc 3/8-16 x 1.25				Cover Assy.
17	56003081	2	Scr, Soc Set Loc 3/8-16 x .38	*	56409832	1	Commutator Cover
18	56003231	2	Key, Wdf .88 x .25	*	56409833	1	Complete Brush Ring Assy.
19	56003240	1	Key, Sq .19 x 1.12	*	56409834	1	Pulley Cover
20	56003245	1	Key, Sq .25 x 1.19	*	56409835	1	Complete Stator Assy.
21	56009002	2	Wsh, Flt .26 x .90 x .06				W/Baffle
22	56009094	6	Wsh, Flt SS .38 x 1.25 x .07	*	56409836	1	Complete Armature Assy.
23	56366455	2	Plate, Stop	39	56392513	6	Spring, Compression
24	56366463	2	Spring Retainer	40	56392530	6	Spacer
25	56391604	2	Pipe Weld't	41	56392552	1	Sheave, Poly-V
26	56391611	2	Holder Casting, Brush				<b>(BA1000 before SN1078241)</b>
27	56392280	1	Belt, Poly-V		56409116	1	Sheave, Poly-V
			<b>(BA1000 before SN1078241)</b>				<b>(BA1000 after SN1078240, all 38LX/380HD)</b>
	56392292	1	Belt, Poly-V	42	56478781	6	Bearing, Sleeve
			<b>(BA1000 after SN1078240, all 38LX/380HD)</b>	43	56009033	2	Scr, Hex Thd Form 1/4-20 x .50
28	56392395	1	Gearbox Assembly				
29	56392396	2	Drive Adaptor Weld't	**	56505790	2	Short Trim Pad Holder
30	56392400	1	Sheave, Poly-V Belt	**	56505791	2	Magna Grit Brush
31	56392402	1	Motor Mount Weld't	**	56505792	2	Dyna Grit Brush
32	56392424	1	Mount, Gearbox Motor	**	56505793	2	AgLite Grit Brush
33	56392431	1	Torsion Bar Weld't	**	56505794	2	Prolene Brush
34	56392444	1	Mount, Linkage Arm	**	56505795	2	ProLite Brush
				**	56505796	2	Union Mix Brush
				**	56505797	2	MidGrit Brush
				**	56505798	2	MidLite Grit Brush

\* = Not Shown  
\*\* = Optional, Not Included

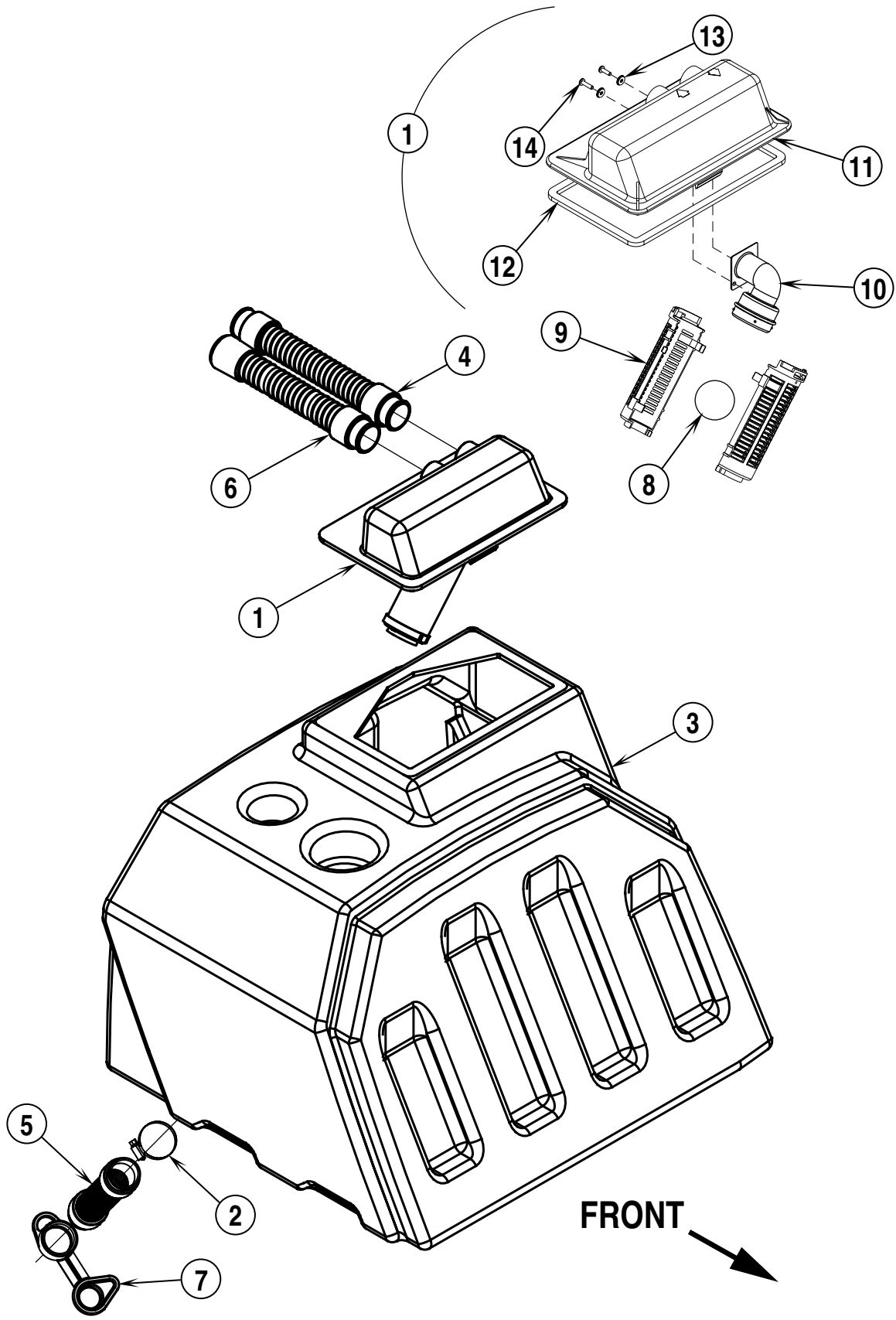

95-5	<b>RECOVERY TANK SYSTEM</b>	<b>BOOK E</b>		
00-12	<b>32LX, 38LX / 320HD, 380HD / BA 800, BA 1000</b>	<b>E</b>	<b>6.3.1</b>	<b>27</b>

Item	Ref. No.	Qty	Description
1	56324045	1	Cover Assembly (#8-14) (all LX's / 320HD before SN 1190874 / 380HD before SN 1187523)
	56324396	1	Cover Assembly (#8-14) (320HD after SN 1190873 / 380HD after SN 1187522, all BA 800/1000)
2	56329145	1	Clamp, Hose SAE #24
3	56392199	1	Tank, Recovery (all LX's / 320HD before SN 1190874 / 380HD before SN 1187523)
	56391371	1	Tank, Recovery (320HD after SN 1190873 / 380HD after SN 1187522, all BA 800/1000)
4	56392205	1	Hose Assembly (Squeegee) (all LX's / 320HD before SN 1190874 / 380HD before SN 1187523)
	56392168	1	Hose Assembly (Squeegee) (320HD after SN 1190873 / 380HD after SN 1187522, all BA 800/1000)
5	56392201	1	Hose Assembly (Drain) (all LX's / 320HD before SN 1190874 / 380HD before SN 1187523)
	56392170	1	Hose Assembly (Drain) (320HD after SN 1190873 / 380HD after SN 1187522, all BA 800/1000)
6	56392229	1	Hose Assembly (Vac Motor) (all LX's / 320HD before SN 1190874 / 380HD before SN 1187523)
	56392228	1	Hose Assembly (Vac Motor) (320HD after SN 1190873 / 380HD after SN 1187522, all BA 800/1000)
7	56324180	1	Plug, Hose (all LX's / 320HD before SN 1190874 / 380HD before SN 1187523)
	56393772	1	Plug, Hose (320HD after SN 1190873 / 380HD after SN 1187522, all BA 800/1000)
8	56391690	1	Ball
9	56324497	2	Cage, Float
10	56324298	1	Elbow, Float
11	56324046	1	Cover, Tank (all LX's / 320HD before SN 1190874 / 380HD before SN 1187523)
	56324395	1	Cover, Tank (320HD after SN 1190873 / 380HD after SN 1187522, all BA 800/1000)
12	56262576	1	Gasket
13	56209261	2	Washer, Sealing 9/16
14	56003633	2	Scr, Pan Phil SS Type B 10-16 x .50

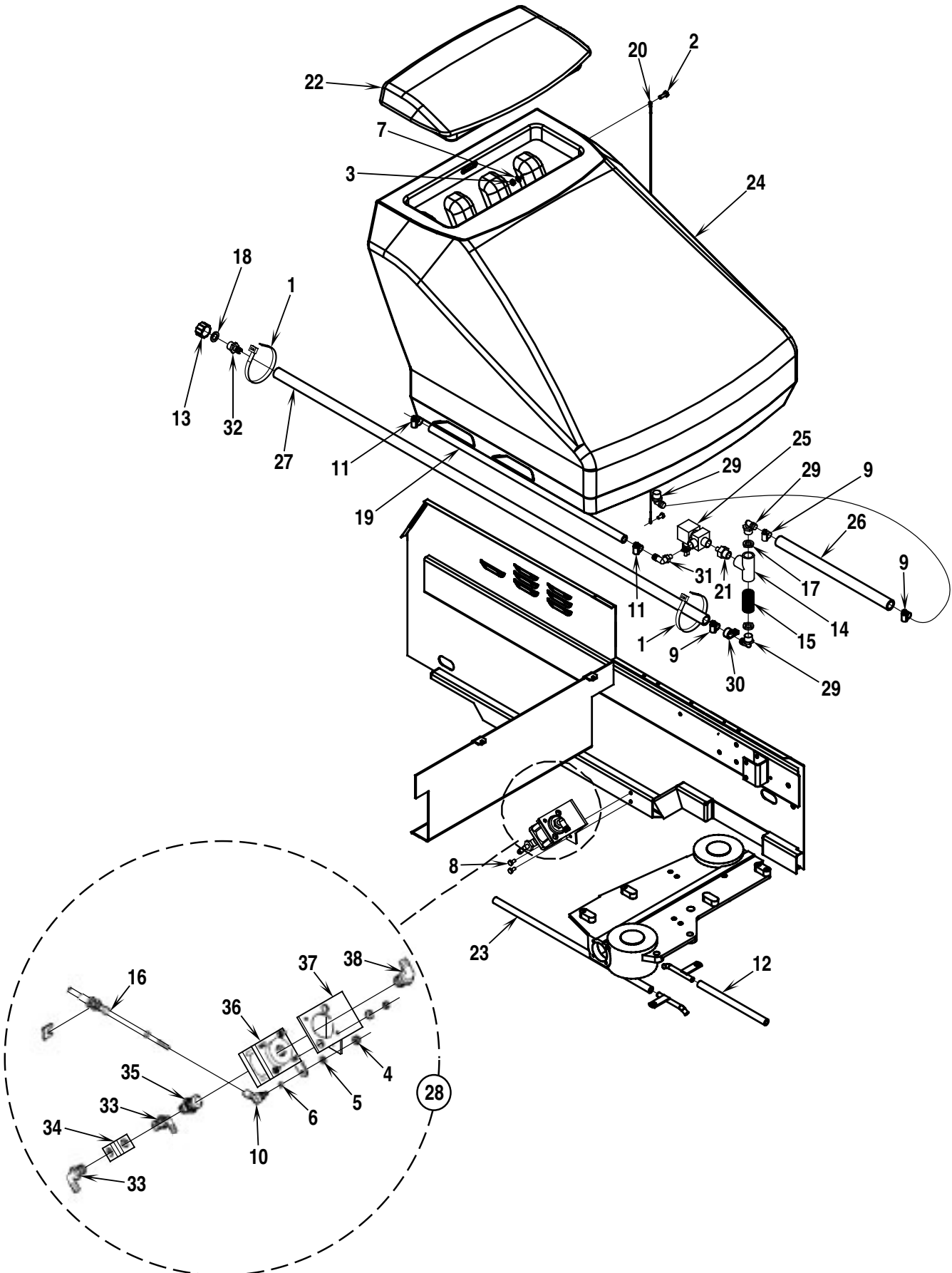

95-5	<b>SOLUTION SYSTEM</b>	<b>BOOK E</b>		
00-12	<b>32LX, 38LX / 320HD, 380HD / BA 800, BA 1000</b>	<b>E</b>	<b>6.3.1</b>	<b>29</b>

Item	Ref. No.	Qty	Description
1	56477613	1	Tie, Cable (qty of 2 on 320HD after SN 1190873 / 380HD after SN 1187522, all BA 800/1000)
2	56002807	1	Scr, Hex Hd SS 1/4-20 x .75
3	56002850	1	Nut, Hex Nyl Loc-Thin SS 1/4-20
4	56002873	1	Nut, Hex Nyl Loc 10-24
5	56001954	1	Wsh, Flt SAE #10
6	56375334	1	Bushing
7	56900737	1	Wsh, Sealing .18 x .56
8	56009033	3	Scr, Hex Thd Form 1/4-20 x .50
9	56112771	4	Clamp, Hose SAE #10 (qty of 2 on 320HD after SN 1190873 / 380HD after SN 1187522, all BA 800/1000)
10	56488290	1	Rod End
11	56219932	4	Clamp, Hose SAE #6 (qty of 2 on 320HD after SN 1190873 / 380HD after SN 1187522, all BA 800/1000)
12	56376444	1	Hose, Spiral
13	56255076	1	Cap, Pipe GHT Nylon
14	56324029	1	Tee
15	56324030	1	Filter
16	56376320	1	Cable (solution valve)
17	56324313	2	Wsh, Rubber
18	56368776	1	Wsh, Rubber
19	56386182	1	Hose, Spiral .50
20	56391282	1	Cable Assembly
21	56391283	1	Nipple, Reducer 3/8 NPT x 3/4 NPT
22	56391396	1	Cover (all LX's / 320HD before SN 1190874 / 380HD before SN 1187523)
	56391377	1	Cover (320HD after SN 1190873 / 380HD after SN 1187522, all BA 800/1000)
23	56391802	1	Hose, Spiral
24	56392209	1	Tank, Solution (all LX's / 320HD before SN 1190874 / 380HD before SN 1187523)
	56393843	1	Tank, Solution (320HD after SN 1190873 / 380HD after SN 1187522)
	56392130	1	Tank, Solution (BA 800)
	56392852	1	Tank, Solution (BA 1000)
25	56392161	1	Solenoid Valve Assembly
*	56324506	1	Viton Seal Kit for 56392161
*	56324507	1	EPDM Seal Kit for 56392161
26	56392193	1	Hose, Spiral
27	56392194	1	Tube, PVC
28	56392413	1	Solution Valve Assembly (#33-38)
29	56456802	3	Barb, Elbow
30	56442003	1	P-Clamp
31	56900069	1	Barb, Elbow 1/2 x 3/8 NPT
32	56900273	1	Barb
33	56900035	2	Barb, Elbow 3/8 x 3/8 NPT
34	56900291	1	Tee, Union 3/8 NPT
35	56900639	1	Nipple, Hex Reducer 3/8 x 1/2
36	56391681	1	Valve, Flow Control
37	56392412	1	Mount, Valve
38	56391678	1	Barb, Hose

\* = Not Shown

### BA 800, BA 1000 Before SN 1081111

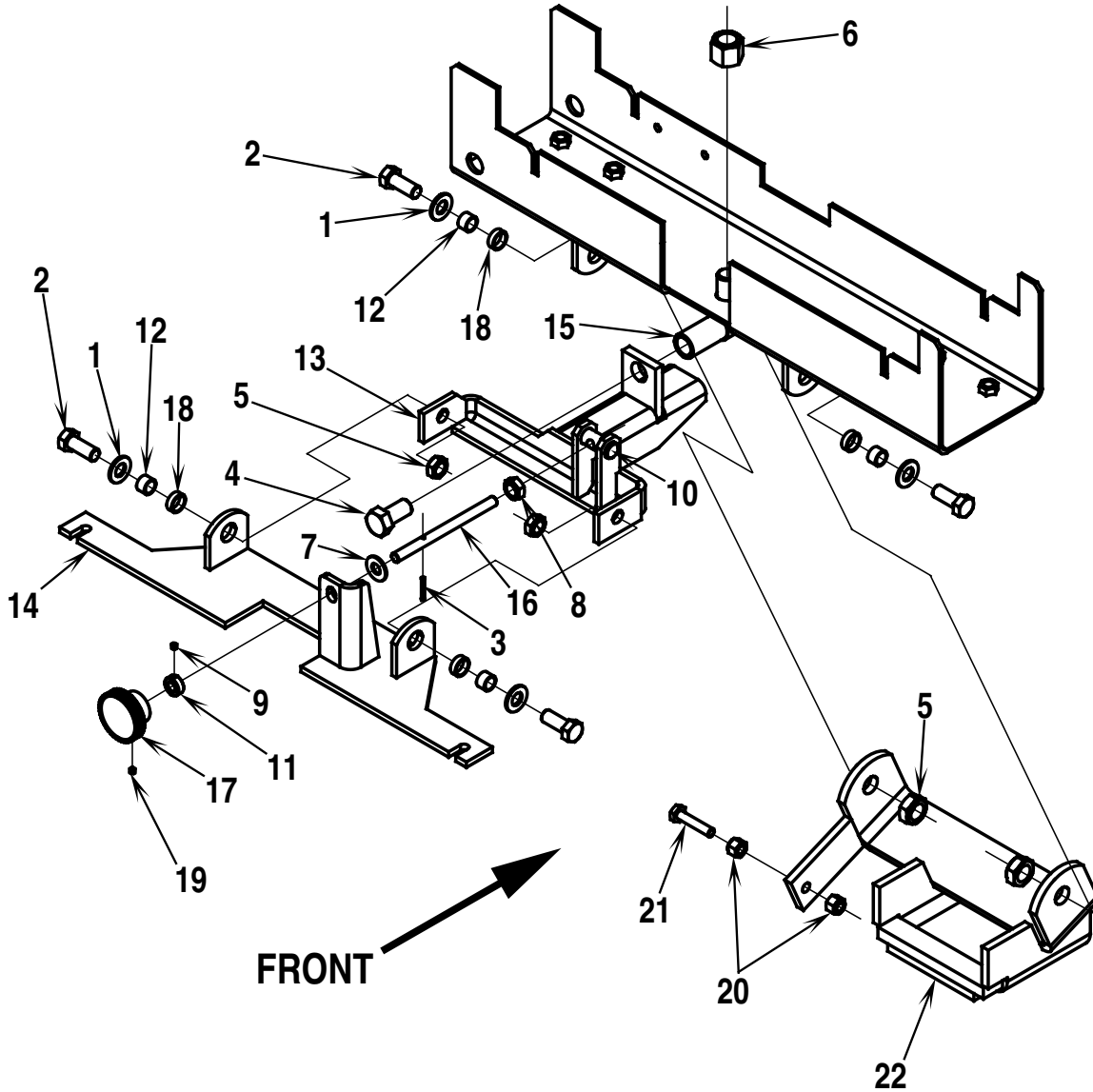

95-5	<b>SQUEEGEE MOUNT ASSEMBLY-1</b>	<b>BOOK E</b>		
01-2	<b>32LX, 38LX / 320HD, 380HD / BA 800, BA 1000</b>	<b>E</b>	<b>6.3.1</b>	<b>31</b>

Item	Ref. No.	Qty	Description
	56392245	1	Squeegee Mount Assembly (#1-19)
1	56001879	4	Wsh, Flt SAE 1/2
2	56001931	4	Scr, Hex Hd 1/2-13 x 1.25
3	56002291	1	Pin, Spr .12 x 1.00
4	56002739	1	Scr, Hex Hd 3/4-16 x 1.25
5	56002843	4	Nut, Hex Nyl Loc-Thin 1/2-13
6	56002863	1	Nut, Hex Nyl Loc 3/4-16
7	56002891	1	Wsh, Flt Std SS 3/8
8	56009085	1	Nut, Hex Jam 3/8-16
9	56002015	1	Scr, Soc Set Loc 10-24 x .25
10	56324369	1	Pin
11	56331076	1	Collar
12	56360627	4	Bushing
13	56391373	1	Mount Weld't
14	56391374	1	Squeegee Mount Weld't
15	56391864	1	Ball Joint
16	56392104	1	Rod, Adjuster
17	56475480	1	Knob
18	56478781	4	Bearing, Sleeve
19	56001823	1	Scr, Soc Set Loc 10-24 x .38
20	56002708	2	Nut, Hex Nyl Loc 1/4-20
21	56001878	1	Scr, Hex Hd 1/4-20 x 1.25
22	56391860	1	Lifter Weld't

BA 800, BA 1000 After SN 1081110  
All 32LX, 38LX / 320HD, 380HD

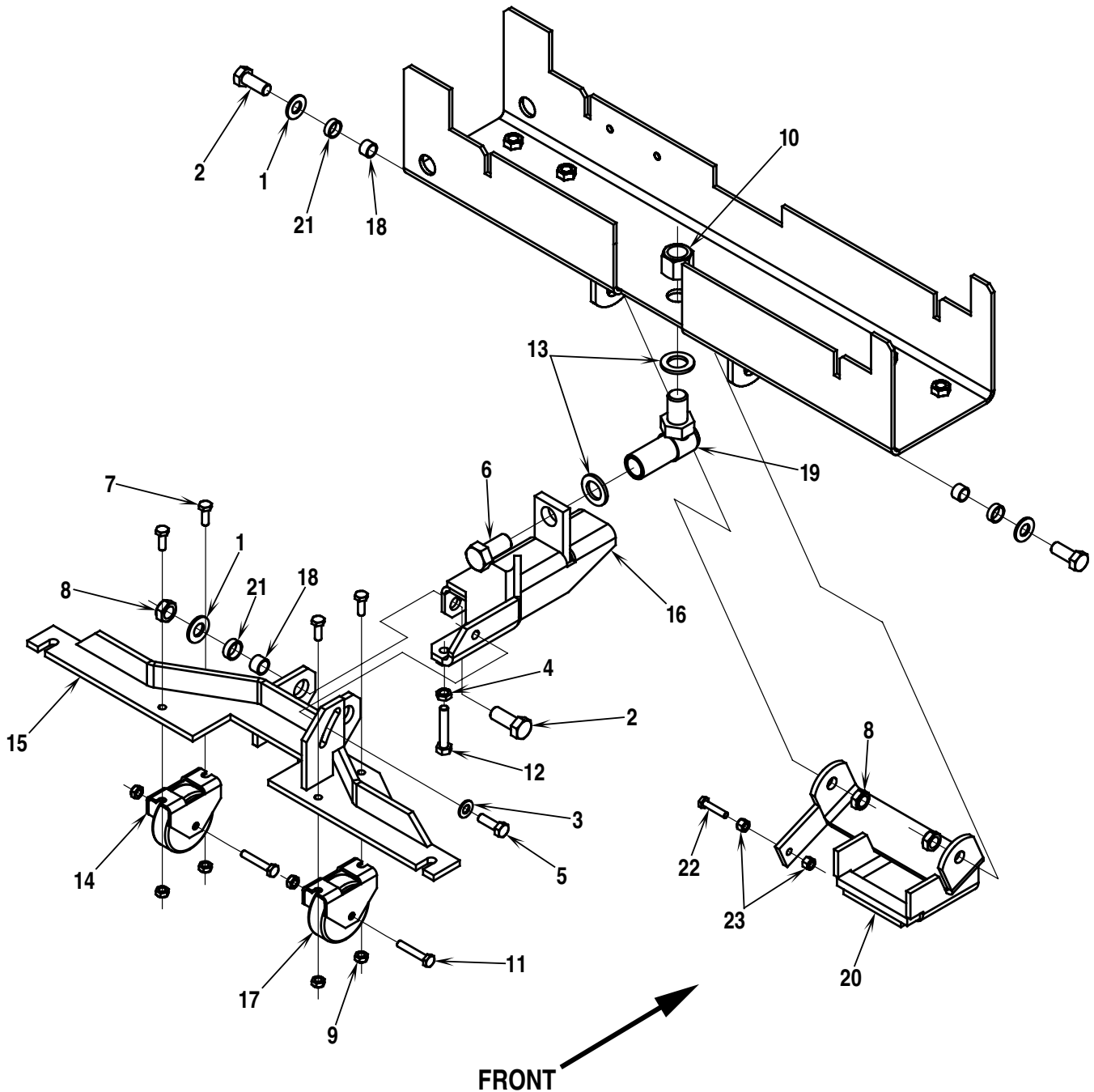

95-5	<b>SQUEEGEE MOUNT ASSEMBLY-2</b>	<b>BOOK E</b>		
00-12	<b>32LX, 38LX / 320HD, 380HD / BA 800, BA 1000</b>	<b>E</b>	<b>6.3.1</b>	<b>33</b>

Item	Ref. No.	Qty	Description
	56392218	1	Squeegee Mount Assembly (#1-19 & 21)
1	56001879	4	Wsh, Flt SAE 1/2
2	56001931	4	Scr, Hex Hd 1/2-13 x 1.25
3	56001939	1	Wsh, Flt SAE 5/16
4	56009141	1	Nut, Hex Jam SS 5/16-18
5	56002221	1	Scr, Hex Hd 5/16-18 x 1.00
6	56002739	1	Scr, Hex Hd 3/4-16 x 1.25
7	56002807	4	Scr, Hex Hd SS 1/4-20 x .75
8	56002843	4	Nut, Hex Nyl Loc-Thin 1/2-13
9	56002850	6	Nut, Hex Nyl Loc-Thin SS 1/4-20
10	56009083	1	Nut, Hex Jam 3/4-16
11	56002901	2	Scr, Hex Hd SS 1/4-20 x 1.50
12	56002872	1	Scr, Hex Thd To Hd SS 5/16-18 x 3.00
13	56009022	2	Wsh, Flt .75 x 1.25 x .12
14	56392217	2	Wheel Bracket
15	56262679	1	Squeegee Mount <b>TSB 655, TSB 668</b>
16	56262677	1	Squeegee Tongue Weld't Ref. <b>TSB 668</b>
17	56324515	2	Wheel <b>TSB 655</b>
18	56360627	4	Bushing
19	56391864	1	Ball Joint
20	56391860	1	Lifter Weld't
21	56478781	4	Bearing, Sleeve
22	56001878	1	Scr, Hex Hd 1/4-20 x 1.25
23	56002708	2	Nut, Hex Nyl Loc 1/4-20

BA 800, BA 1000 Before SN 1081111

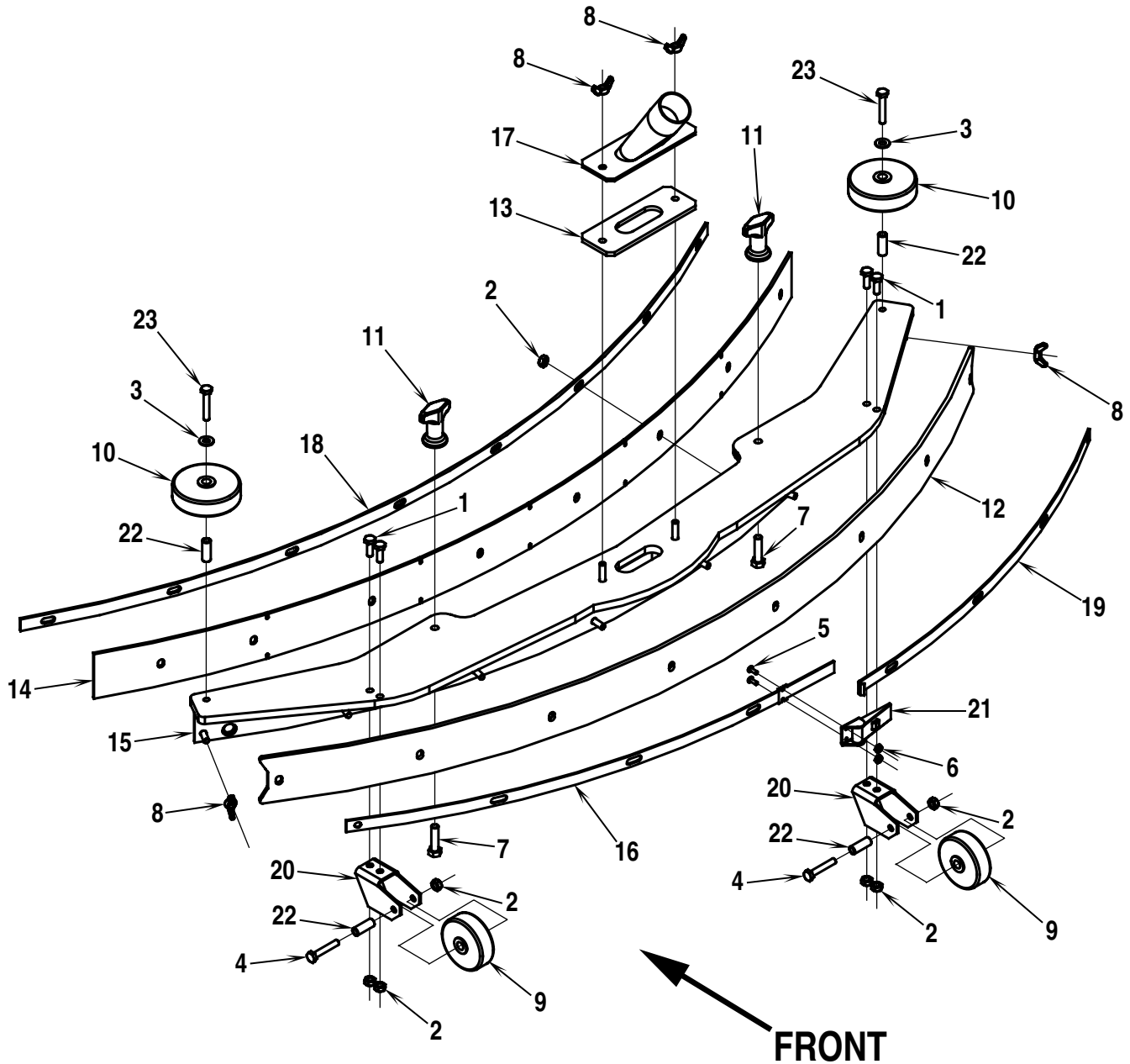

95-5	<b>SQUEEGEE ASSEMBLY-1</b>	<b>BOOK E</b>		
00-12	<b>32LX, 38LX / 320HD, 380HD / BA 800, BA 1000</b>	<b>E</b>	<b>6.3.1</b>	<b>35</b>

Item	Ref. No.	Qty	Description
	56409808	1	Squeegee Assembly (#1-23)
1	56002807	4	Scr, Hex Hd SS 1/4-20 x .75
2	56002850	14	Nut, Hex Nyl Loc-Thin SS 1/4-20
3	56002859	2	Wsh, Flt SAE SS 1/4
4	56002901	2	Scr, Hex Hd SS 1/4-20 x 1.50
5	56002909	2	Scr, Pan Phil SS 6-32 x .38
6	56002964	2	Nut, Hex Nyl Loc-Thin SS 6-32
7	56003302	2	Scr, Hex Thd to Hd SS 5/16-18 x 2.75
8	56009111	4	Nut, Wing SS 1/4-20
9	56324350	2	Wheel
10	56324499	2	Wheel 3.00
11	56370711	2	Nut, Thumb
12	56409413	1	Blade, Rear ( <b>std</b> )
	56409431	1	Blade, Rear ( <b>oil resistant</b> )
13	56409426	1	Gasket
14	56409627	1	Blade, Front ( <b>std</b> )
	56409414	1	Blade, Front ( <b>oil resistant</b> )
15	56409422	1	Tool Weld't
16	56409415	1	Strap, Left Rear
17	56409425	1	Tube Weld't
18	56409417	1	Strap, Front
19	56409416	1	Strap, Right Rear
20	56409656	2	Bracket, Wheel
21	56471194	1	Latch
22	56471220	4	Bushing
23	56002993	2	Scr, Hex Hd Loc SS 1/4-20 x 1.50
	56409429	1	Standard Squeegee Blade Kit (#12 & 14)
	56409430	1	Oil Resistant Squeegee Blade Kit (#12 & 14)

**BA 800, BA 1000 After SN 1081110**  
**All 32LX, 38LX / 320HD, 380HD**

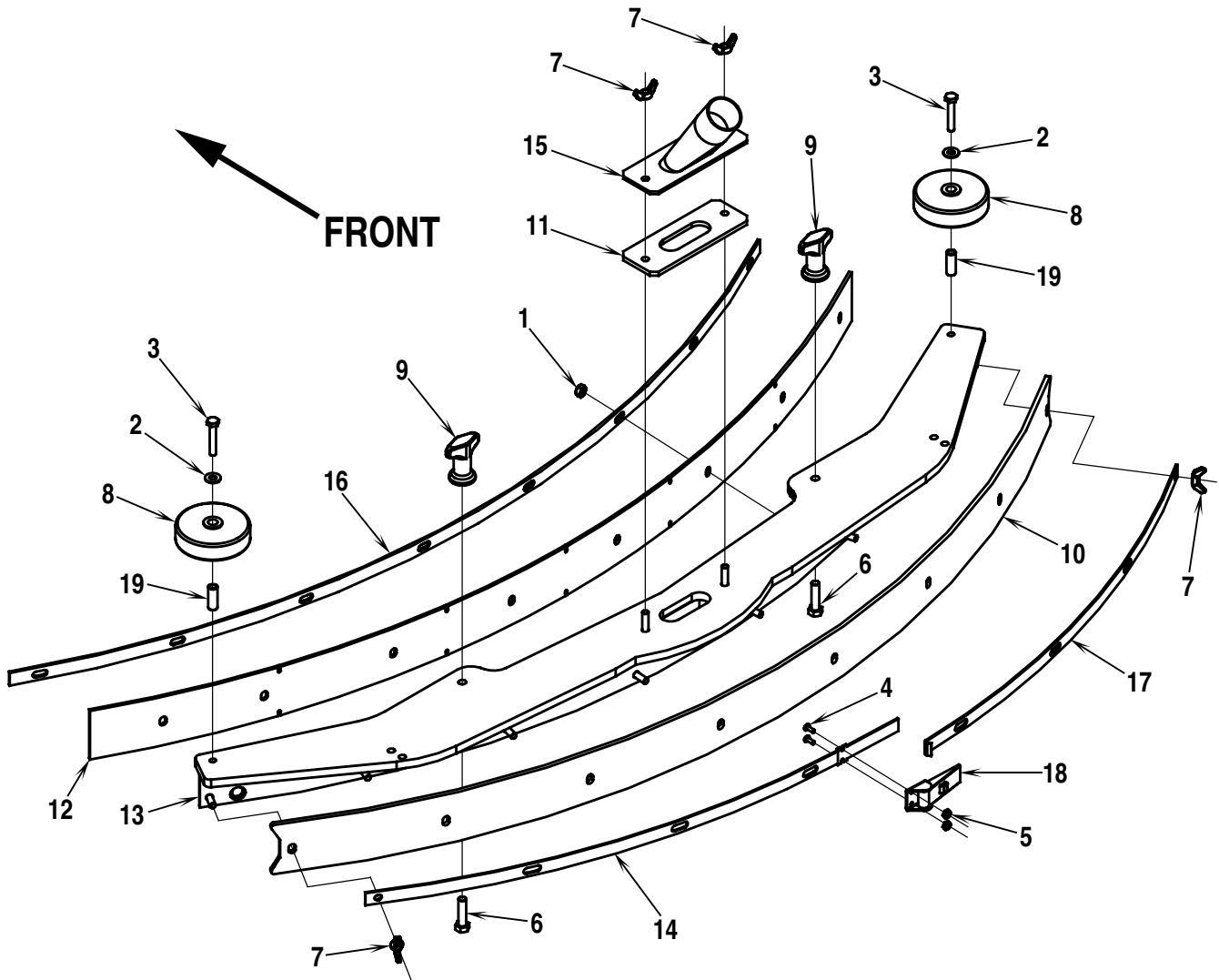

95-5	<b>SQUEEGEE ASSEMBLY-2</b>	<b>BOOK E</b>		
00-12	<b>32LX, 38LX / 320HD, 380HD / BA 800, BA 1000</b>	<b>E</b>	<b>6.3.1</b>	<b>37</b>

Item	Ref. No.	Qty	Description
	56409423	1	Squeegee Assembly (#1-19)
1	56002850	8	Nut, Hex Nyl Loc-Thin SS 1/4-20
2	56002859	2	Wsh, Flt SAE SS 1/4
3	56002993	2	Scr, Hex Hd Loc SS 1/4-20 x 1.50
4	56002909	2	Scr, Pan Phil SS 6-32 x .38
5	56002964	2	Nut, Hex Nyl Loc-Thin SS 6-32
6	56003302	2	Scr, Hex Thd to Hd SS 5/16-18 x 1.25
7	56009111	4	Nut, Wing SS 1/4-20
8	56324499	2	Wheel 3.00
9	56370711	2	Nut, Thumb
10	56409413	1	Blade, Rear ( <b>std</b> )
	56409431	1	Blade, Rear ( <b>oil resistant</b> )
11	56409426	1	Gasket
12	56409627	1	Blade, Front ( <b>std</b> )
	56409414	1	Blade, Front ( <b>oil resistant</b> )
13	56409422	1	Tool Weld't
14	56409415	1	Strap, Left Rear
15	56409425	1	Tube Weld't
16	56409417	1	Strap, Front
17	56409416	1	Strap, Right Rear
18	56471194	1	Latch
19	56471220	2	Bushing
	56409429	1	Standard Squeegee Blade Kit (#10 & 12)
	56409430	1	Oil Resistant Squeegee Blade Kit (#10 & 12)

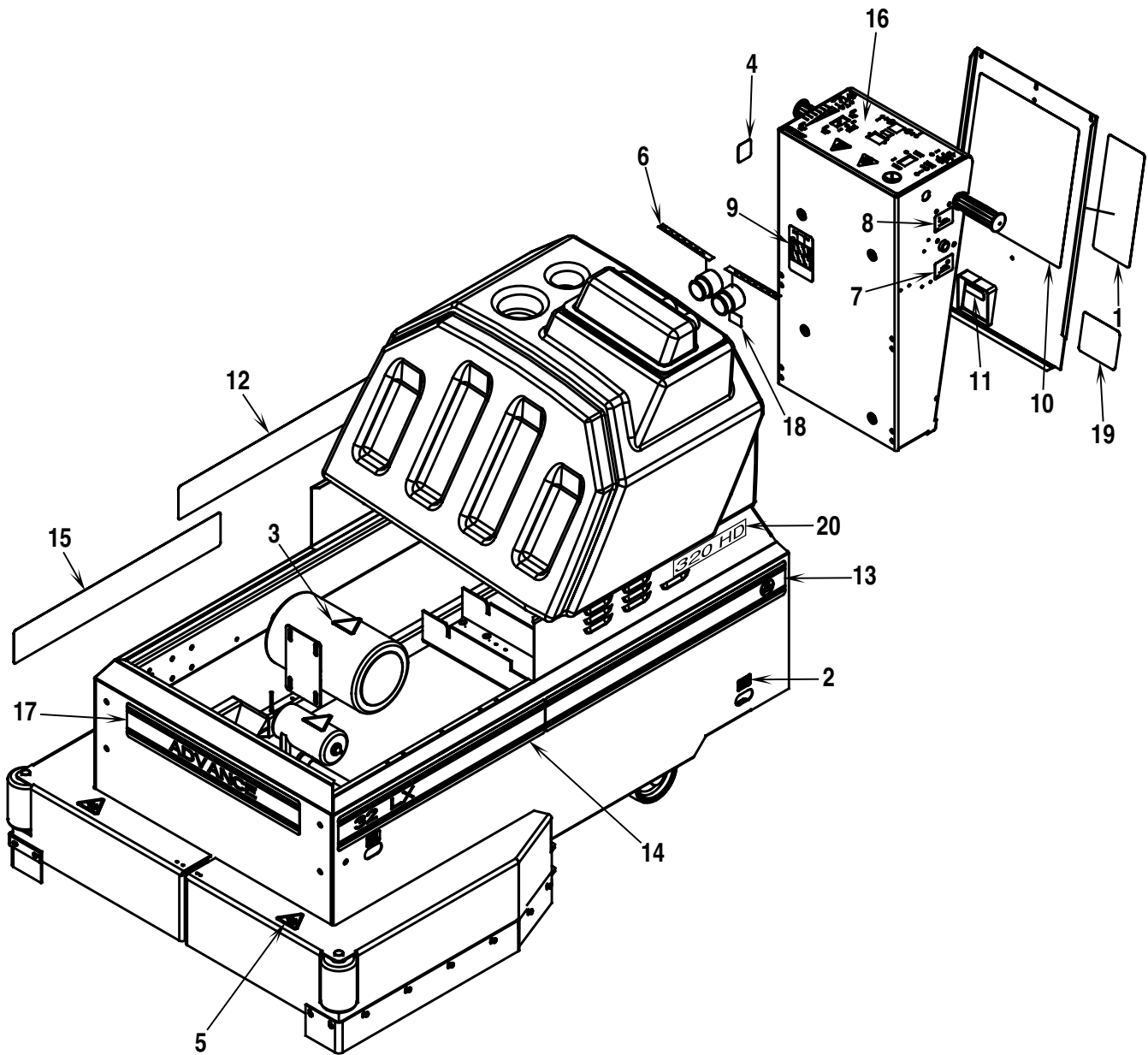

95-5	<b>DECAL SYSTEM (Advance)</b>	<b>BOOK E</b>		
00-12	<b>32LX, 38LX / 320HD, 380HD / BA 800, BA 1000</b>	<b>E</b>	<b>6.3.1</b>	<b>39</b>

Item	Ref. No.	Qty	Description
1	56014601	1	Decal, Caution
2	56015370	4	Decal, Tie Down
3	56015464	2	Decal, Hand Entanglement
4	56015469	1	Decal, Brake Release
5	56015506	2	Decal, Rotating Brush Hazzard
6	56015655	2	Decal, Direction
7	56015711	1	Decal, Squeegee Up
8	56015712	1	Decal, Squeegee Down
9	56015765	1	Decal, Cable Routing
10	56015777	1	Decal, Wiring
11	56015779	1	Decal, Circuit Breakers
12	56015793	1	Decal, Stripe Rear Right (all LX's / 320HD before SN 1190874 / 380HD before SN 1187523)
13	56015794	1	Decal, Stripe Rear Left (all LX's / 320HD before SN 1190874 / 380HD before SN 1187523)
14	56015797	1	Decal, Stripe Left - 32LX
*	56015788	1	Decal, Stripe Left - 38LX
*	56015795	1	Decal, Stripe Left - 320HD (only before SN 1190874)
*	56015790	1	Decal, Stripe Left - 380HD (only before SN 1187523)
15	56015798	1	Decal, Stripe Right - 32LX
*	56015789	1	Decal, Stripe Right - 38LX
*	56015796	1	Decal, Stripe Right - 320HD (only before SN 1190874)
*	56015791	1	Decal, Stripe Right - 380HD (only before SN 1187523)
16	56015801	1	Decal, Control Panel
17	56015802	1	Decal, Stripe Front (all LX's / 320HD before SN 1190874 / 380HD before SN 1187523)
18	56016324	1	Decal, Charger
19	56016019	1	Decal, Wear Items - 32LX
	56016016	1	Decal, Wear Items - 38LX
	56016037	1	Decal, Wear Items - 380HD
20	56015996	2	Decal, 320HD (only after SN 1190873)
	56015998	2	Decal, 380HD (only after SN 1187522)

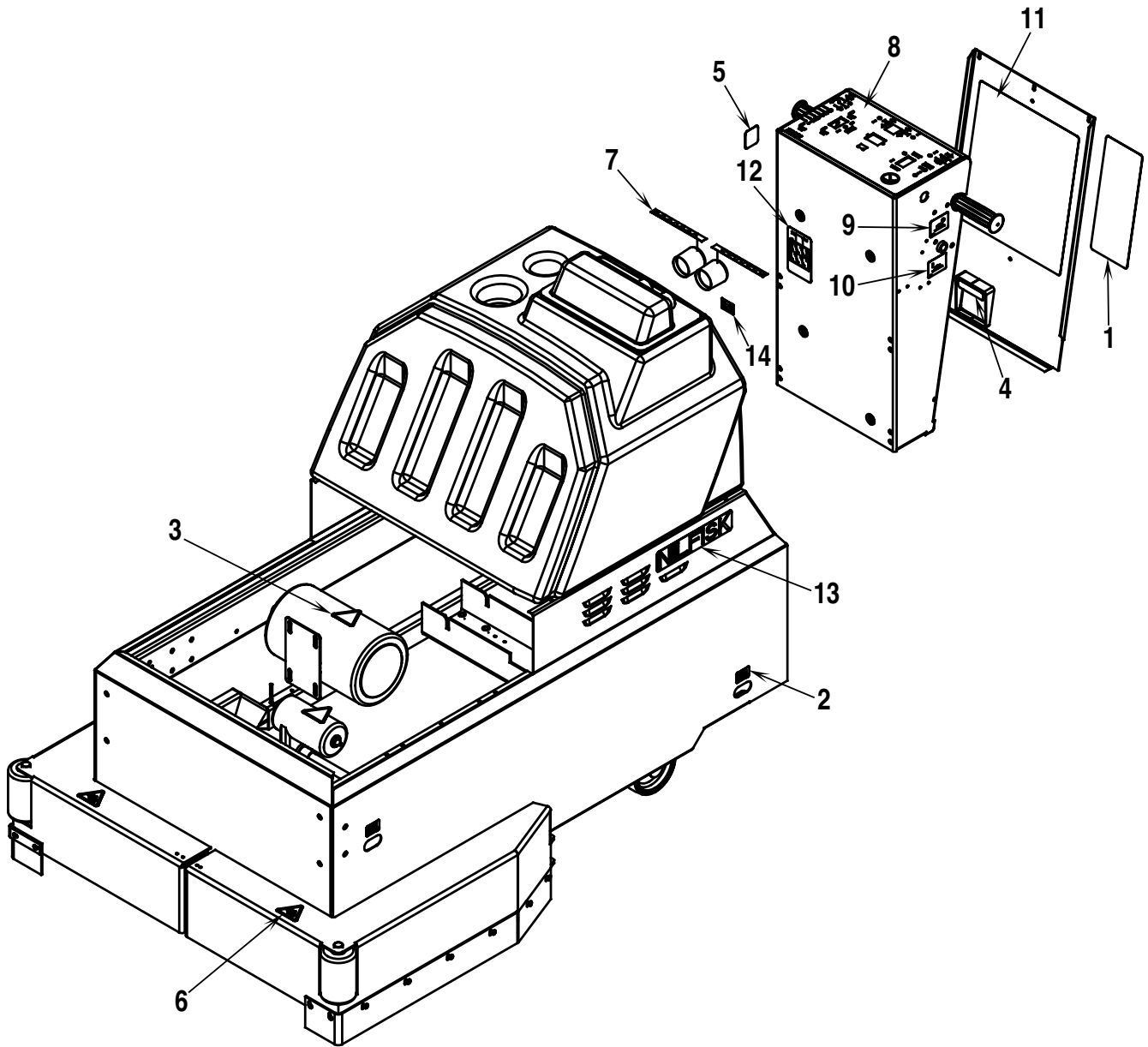

95-5	<b>DECAL SYSTEM (Nilfisk)</b>	<b>BOOK E</b>		
00-12	<b>32LX, 38LX / 320HD, 380HD / BA 800, BA 1000</b>	<b>E</b>	<b>6.3.1</b>	<b>41</b>

Item	Ref. No.	Qty	Description
1	56014601	1	Decal, Caution
2	56015370	4	Decal, Tie Down
3	56015464	2	Decal, Hand Entanglement
4	56015465	1	Decal, Circuit Breakers
5	56015469	1	Decal, Brake Release
6	56015506	2	Decal, Rotating Brush Hazard
7	56015655	2	Decal, Direction
8	56015700	1	Decal, Control Panel
9	56015711	1	Decal, Squeegee Up
10	56015712	1	Decal, Squeegee Down
11	56015764	1	Decal, Wiring
12	56015765	1	Decal, Cable Routing
13	56015766	2	Decal, Nilfisk
14	56016324	1	Decal, Charger



95-5	<b>ELECTRICAL SYSTEM-1</b>	<b>BOOK E</b>		
00-12	<b>32LX, 38LX / 320HD, 380HD / BA 800, BA 1000</b>	<b>E</b>	<b>6.3.1</b>	<b>43</b>

Item	Ref. No.	Qty	Description
1	56001861	2	Scr, Hex Hd 1/4-20 x .38
2	56002040	2	Nut, Hex Jam 1/4-20
3	56009064	2	Wsh, Int Shprf 1/4
4	56372673	12	Boot, Battery Post
5	56389232	4	Cable Assembly 4 x 8
6	56392154	1	Harness, Wiring
7	56392157	1	Cable Assembly 4 x 60
8	56392158	1	Cable Assembly 4 x60
9	56392159	1	Connector Assembly ( <b>Charger Plug</b> )
10	56454376	2	Stud, 1/4-20
11	56456460	1	Cable Assembly 4 x 12
12	56462362	1	Switch Assembly ( <b>Charger Interlock</b> )
13	56469858	2	Standoff, Insulated
14	56477613	12	Tie, Cable
15	56478246	22	Tie, Cable
16	56493357	2	Insulator, Terminal
17	56900753	2	Tie, Push Mount



95-5	<b>ELECTRICAL SYSTEM-2</b>	<b>BOOK E</b>		
00-12	<b>32LX, 38LX / 320HD, 380HD / BA 800, BA 1000</b>	<b>E</b>	<b>6.3.1</b>	<b>45</b>

Item	Ref. No.	Qty	Description
1	56001861	4	Scr, Hex Hd 1/4-20 x .38
2	56002040	4	Nut, Hex Jam 1/4-20
3	56009064	4	Wsh, Int Shprf 1/4
4	56372673	12	Boot, Battery Post
5	56389232	4	Cable Assembly 4 x 8
6	56392197	1	Harness, Wiring
7	56392157	1	Cable Assembly 4 x 60
8	56392158	1	Cable Assembly 4 x 60
9	56392159	1	Connector Assembly ( <b>Charger Plug</b> )
10	56454376	4	Stud, 1/4-20
11	56456460	1	Cable Assembly 4 x 12
12	56462362	1	Switch Assembly ( <b>Charger Interlock</b> )
13	56469858	4	Standoff, Insulated
14	56477613	12	Tie, Cable
15	56478246	22	Tie, Cable
16	56900753	2	Tie, Push Mount
*	56002701	12	Nut, Hex Nyl Loc 5/16-18 <b>NOTE 1</b>
*	56001834	12	Scr, Hex Hd 5/16-18 x 1.25 <b>NOTE 1</b>

**NOTE 1:** This hardware is required with the use of 244 AH batteries.

\* = Not Shown

### BA 800, BA 1000 Before SN 1081111

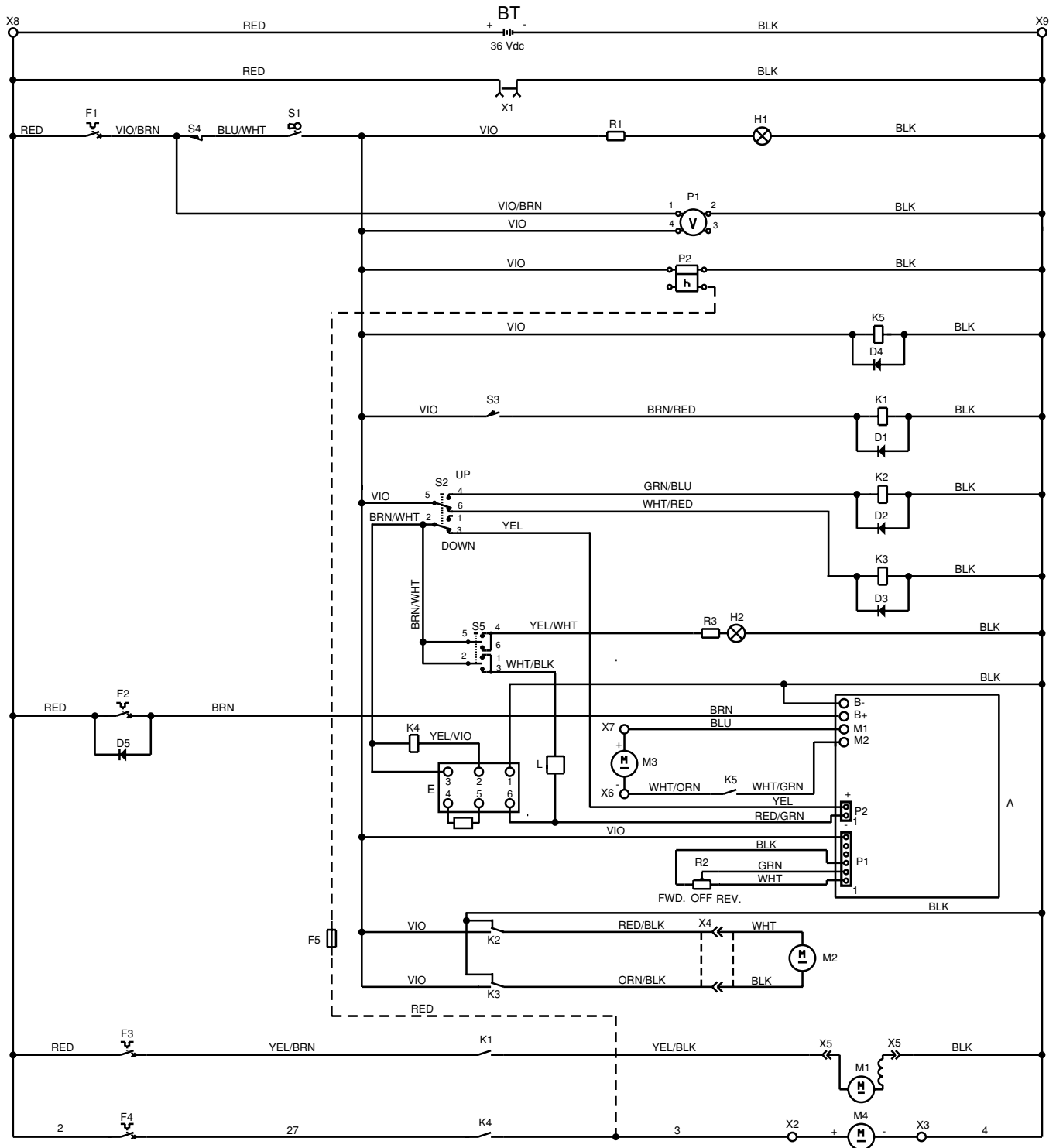

95-5	<b>WIRING DIAGRAM-1</b>	<b>BOOK E</b>		
01-2	<b>32LX, 38LX / 320HD, 380HD / BA 800, BA 1000</b>	<b>E</b>	<b>6.3.1</b>	<b>47</b>

Item	Ref. No.	Qty	Description
A	56391210	1	Speed Controller
BT		6	Battery 6V
D1	56389265	1	Suppression Diode
D2	56389265	1	Suppression Diode
D3	56389265	1	Suppression Diode
D4	56389265	1	Suppression Diode
D5			Regenerative Feedback Diode
E	56391357	1	Time Delay Module
F1	56387328	1	5 Amp Circuit Breaker ( <b>Control Circuit</b> )
F2	56469788	1	25 Amp Circuit Breaker ( <b>Wheel Drive</b> )
F3	56469788	1	25 Amp Circuit Breaker ( <b>Vacuum Motor</b> )
F4	56454429	1	70 Amp Circuit Breaker ( <b>Brush Motor</b> )
F5			4 Amp Fuse
H1	56389434	1	Green Indicator Light
H2	56324028	1	Blue Indicator Light
K1	56395452	1	Vacuum Motor Solenoid
K2	56388534	1	Actuator Motor Up Solenoid
K3	56388534	1	Actuator Motor Down Solenoid
K4	56395452	1	Brush Motor Solenoid
K5	56395452	1	Wheel Drive Motor Solenoid
L	56392161	1	Solenoid Valve
M1	56391208	1	Vacuum Motor
M2	56391627	1	Actuator Motor
M3	56388585	1	Wheel Drive Motor
M4	56409126	1	Brush Motor
P1	56393717	1	Battery Fuel Gauge
P2			Hour Meter (optional)
R1			330 Ohm Resistor
R2	56454740	1	5K Ohm Potentiometer
R3			330 Ohm Resistor
S1	56301636	1	Main Switch
S2	56393312	1	Brush Switch
S3	56324362	1	Vacuum Motor Switch
S4	56462362	1	Charger Interlock Switch
S5	56324272	1	Solution Switch <b>TSB 663</b>
X1	56392159	1	Charger Connector
X2			Brush Motor + Terminal Stud
X3			Brush Motor - Terminal Stud
X4			Actuator Motor Connector
X5			Vacuum Motor Connector
X6			Wheel Drive Motor - Terminal Stud
X7			Wheel Drive Motor + Terminal Stud
X8			+ Terminal Stud
X9			- Terminal Stud

### BA 800, BA 1000 Before SN 1082119 32LX, 38LX / 320HD, 380HD Before SN1082119

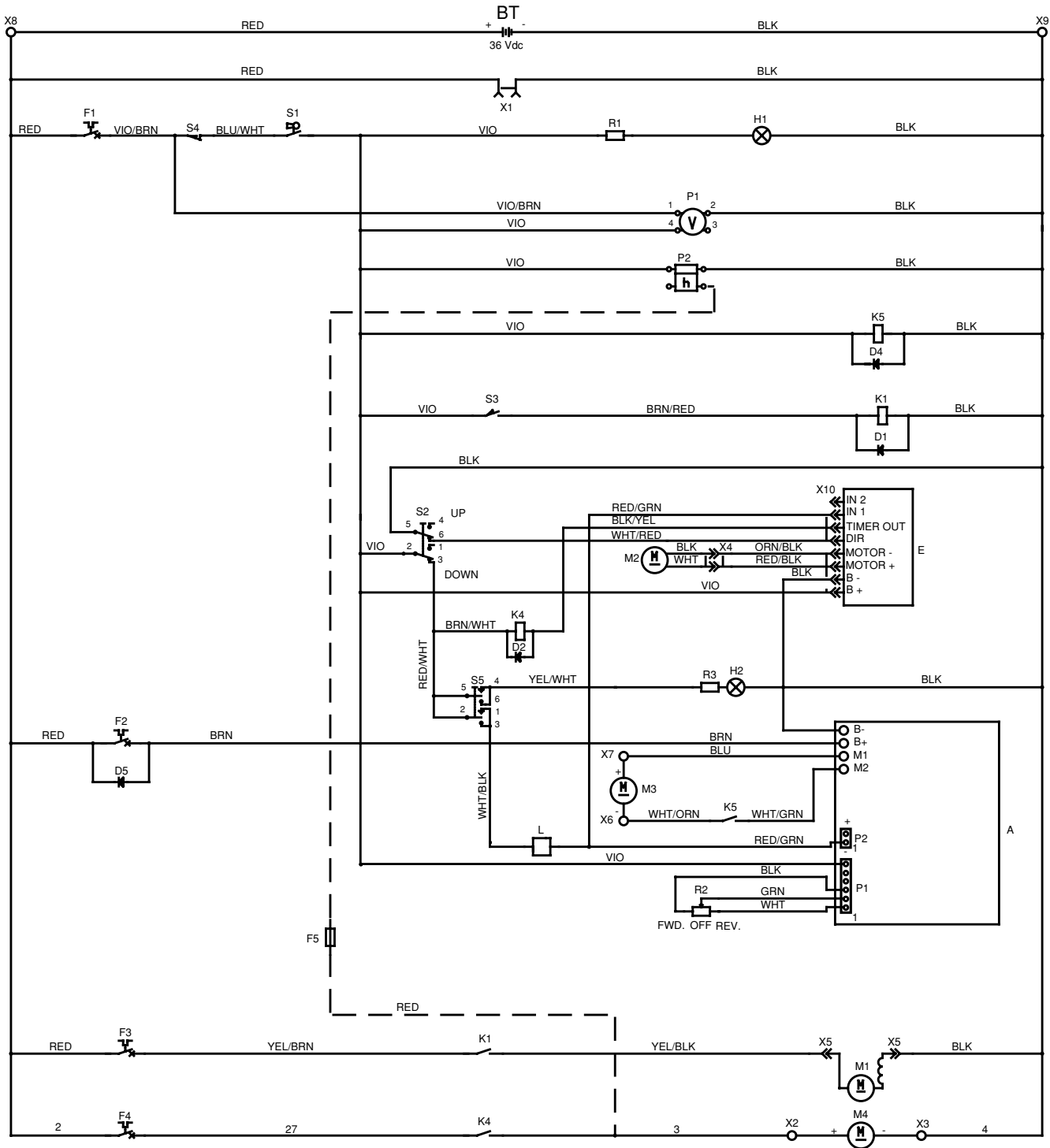

95-5	<b>WIRING DIAGRAM-2</b>	<b>BOOK E</b>		
01-2	<b>32LX, 38LX / 320HD, 380HD / BA 800, BA 1000</b>	<b>E</b>	<b>6.3.1</b>	<b>49</b>

Item	Ref. No.	Qty	Description
A	56391210	1	Speed Controller
BT		6	Battery 6V
D1	56389265	1	Suppression Diode
D2	56389265	1	Suppression Diode
D4	56389265	1	Suppression Diode
D5			Regenerative Feedback Diode
E	56392173	1	Actuator Control Module
F1	56387328	1	5 Amp Circuit Breaker ( <b>Control Circuit</b> )
F2	56469788	1	25 Amp Circuit Breaker ( <b>Wheel Drive</b> )
F3	56469788	1	25 Amp Circuit Breaker ( <b>Vacuum Motor</b> )
F4	56409230	1	80 Amp Circuit Breaker ( <b>Brush Motor</b> )
F5			4 Amp Fuse
H1	56389434	1	Green Indicator Light
H2	56324028	1	Blue Indicator Light
K1	56395452	1	Vacuum Motor Solenoid
K4	56395450	1	Brush Motor Solenoid
K5	56395452	1	Wheel Drive Motor Solenoid
L	56392161	1	Solenoid Valve
M1	56391208	1	Vacuum Motor
M2	56391627	1	Actuator Motor
M3	56388585	1	Wheel Drive Motor
M4	56409126	1	Brush Motor
P1	56393717	1	Battery Fuel Gauge
P2			Hour Meter ( <b>Optional</b> )
R1			330 Ohm Resistor
R2	56454740	1	5K Ohm Potentiometer
R3			330 Ohm Resistor
S1	56301636	1	Main Switch
S2	56393312	1	Brush Switch
S3	56324362	1	Vacuum Motor Switch
S4	56462362	1	Charger Interlock Switch
S5	56324272	1	Solution Switch <b>TSB 663</b>
X1	56392159	1	Charger Connector
X2			Brush Motor + Terminal Stud
X3			Brush Motor - Terminal Stud
X4			Actuator Motor Connector
X5			Vacuum Motor Connector
X6			Wheel Drive Motor - Terminal Stud
X7			Wheel Drive Motor + Terminal Stud
X8			+ Terminal Stud
X9			- Terminal Stud
X10			Actuator Control Module Connector
X11			Speed Controller Connector

### All Models After SN1082118

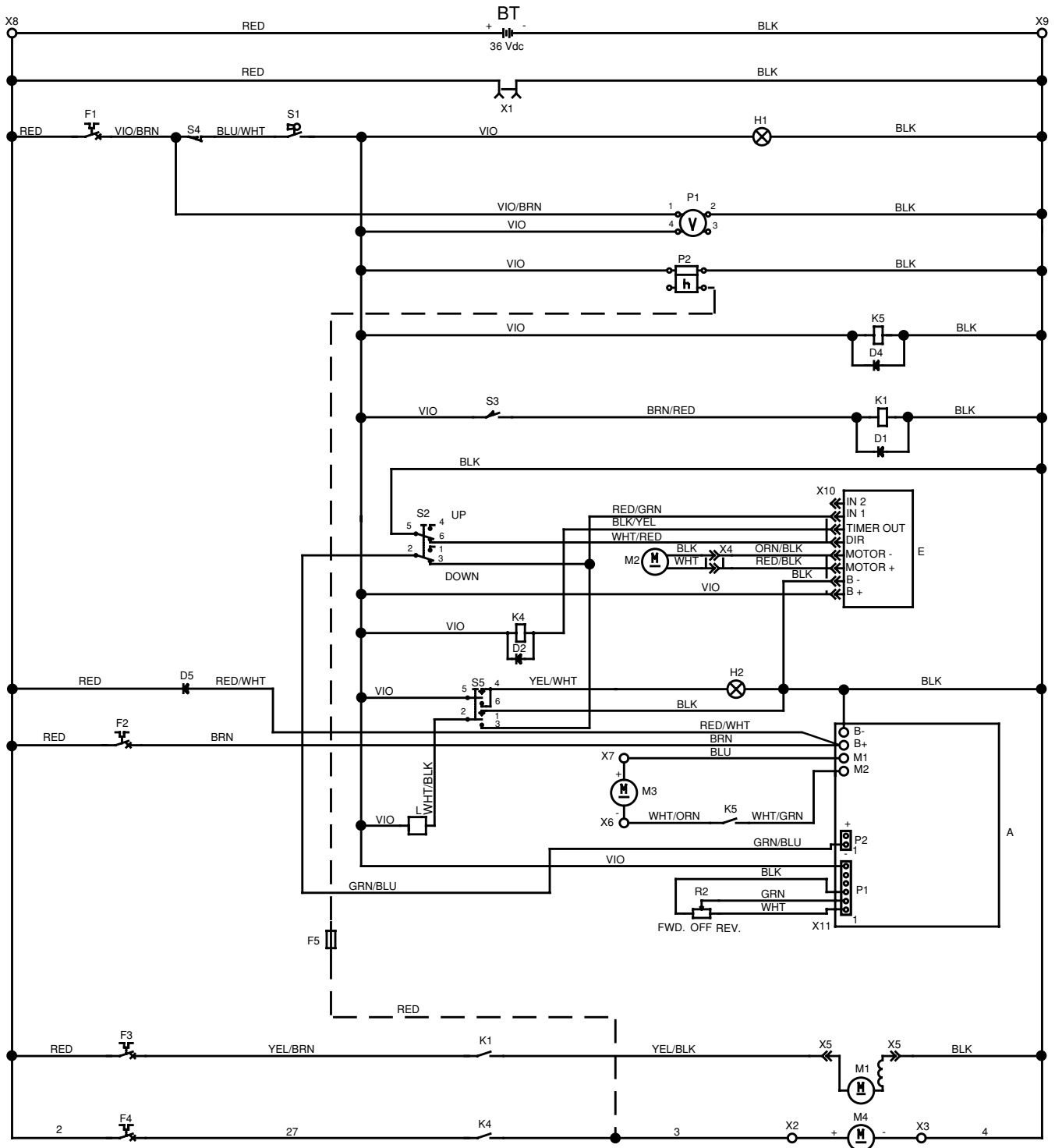

95-5	<b>WIRING DIAGRAM-3</b>	<b>BOOK E</b>		
01-2	<b>32LX, 38LX / 320HD, 380HD / BA 800, BA 1000</b>	<b>E</b>	<b>6.3.1</b>	<b>51</b>

Item	Ref. No.	Qty	Description
A	56391210	1	Speed Controller
BT		6	Battery 6V
D1	56389265	1	Suppression Diode
D2	56389265	1	Suppression Diode
D4	56389265	1	Suppression Diode
D5			Regenerative Feedback Diode
E	56392173	1	Actuator Control Module
F1	56387328	1	5 Amp Circuit Breaker ( <b>Control Circuit</b> )
F2	56469788	1	25 Amp Circuit Breaker ( <b>Wheel Drive</b> )
F3	56469788	1	25 Amp Circuit Breaker ( <b>Vacuum Motor</b> )
F4	56409230	1	80 Amp Circuit Breaker ( <b>Brush Motor</b> )
F5			4 Amp Fuse
H1	56389434	1	Green Indicator Light
H2	56324028	1	Blue Indicator Light
K1	56395452	1	Vacuum Motor Solenoid
K4	56395450	1	Brush Motor Solenoid
K5	56395452	1	Wheel Drive Motor Solenoid
L	56392161	1	Solenoid Valve
M1	56391208	1	Vacuum Motor
M2	56391627	1	Actuator Motor
M3	56388585	1	Wheel Drive Motor
M4	56409126	1	Brush Motor
P1	56393717	1	Battery Fuel Gauge
P2			Hour Meter ( <b>Optional</b> )
R2	56454740	1	5K Ohm Potentiometer
S1	56301636	1	Main Switch
S2	56393312	1	Brush Switch
S3	56324362	1	Vacuum Motor Switch
S4	56462362	1	Charger Interlock Switch
S5	56324272	1	Solution Switch <b>TSB 663</b>
X1	56392159	1	Charger Connector
X2			Brush Motor + Terminal Stud
X3			Brush Motor - Terminal Stud
X4			Actuator Motor Connector
X5			Vacuum Motor Connector
X6			Wheel Drive Motor - Terminal Stud
X7			Wheel Drive Motor + Terminal Stud
X8			+ Terminal Stud
X9			- Terminal Stud
X10			Actuator Control Module Connector
X11			Speed Controller Connector

We manufacture brushes and pad holders that will give you the best possible performance between machine and floor. Following are descriptions of the materials and their applications when used on the BA 800.

- Union Mix:** Medium grade natural fibers for polishing finished floors with standard-speed equipment. Recommended for use in place of white pads.
- ProLite:** Bristles are made from light-duty polypropylene for general scrubbing when you do not want to scratch or remove finish from the floor. Recommended for use in place of red pads.
- Prolene:** Polypropylene material for medium-duty scrubbing on concrete, terrazzo and vinyl floor tile. Recommended for use in place of green or blue pads.
- Magna Grit:** For extreme heavy-duty scrubbing or stripping of floors. This brush has extra large diameter silicon carbide grit impregnated synthetic bristles. Recommended for use in place of black pads.
- Dyna Grit:** For aggressive, heavy-duty scrubbing or stripping of floors. Recommended for use in place of brown pads.
- MidLite Grit:** For general purpose scrubbing of sealed or unsealed concrete, stone, terrazzo, quarry tile and other resilient hard floor surfaces. Recommended for use in place of green or blue pads.
- MidGrit:** For general purpose scrubbing when you need a lighter action for sealed or unsealed concrete, stone, terrazzo, quarry tile and other resilient hard floor surfaces. Recommended for use in place of green or blue pads.
- AgLite Grit:** For light scrubbing when used wet; buffing or polishing when used dry on urethane coated, sealed concrete or other resilient hard surface floors. Recommended for use in place of red or white pads.
- Short Trim Pad Holder:** Made with a structural foam block and center ring for correct pad centering. It has a "shower feed" design for getting solution to the floor.

- Ref. No.:** 56505786 - Union Mix  
 56505784 - Prolene  
 56505782 - Dyna Grit  
 56505787 - MidGrit  
 56505780 - Short Trim Pad Holder  
 56505785 - ProLite  
 56505781 - Magna Grit  
 56505788 - MidLite Grit  
 56505783 - AgLite Grit

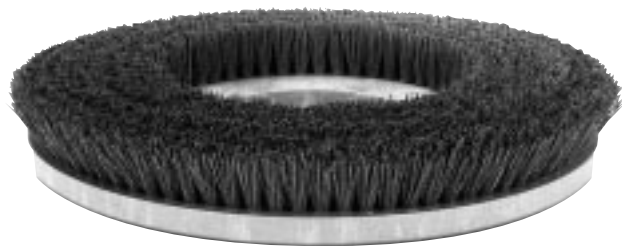

We manufacture brushes and pad holders that will give you the best possible performance between machine and floor. Following are descriptions of the materials and their applications when used on the BA 1000.

- Union Mix:** Medium grade natural fibers for polishing finished floors with standard-speed equipment. Recommended for use in place of white pads.
- ProLite:** Bristles are made from light-duty polypropylene for general scrubbing when you do not want to scratch or remove finish from the floor. Recommended for use in place of red pads.
- Prolene:** Polypropylene material for medium-duty scrubbing on concrete, terrazzo and vinyl floor tile. Recommended for use in place of green or blue pads.
- Magna Grit:** For extreme heavy-duty scrubbing or stripping of floors. This brush has extra large diameter silicon carbide grit impregnated synthetic bristles. Recommended for use in place of black pads.
- Dyna Grit:** For aggressive, heavy-duty scrubbing or stripping of floors. Recommended for use in place of brown pads.
- MidLite Grit:** For general purpose scrubbing of sealed or unsealed concrete, stone, terrazzo, quarry tile and other resilient hard floor surfaces. Recommended for use in place of green or blue pads.
- MidGrit:** For general purpose scrubbing when you need a lighter action for sealed or unsealed concrete, stone, terrazzo, quarry tile and other resilient hard floor surfaces. Recommended for use in place of green or blue pads.
- AgLite Grit:** For light scrubbing when used wet; buffing or polishing when used dry on urethane coated, sealed concrete or other resilient hard surface floors. Recommended for use in place of red or white pads.
- Short Trim Pad Holder:** Made with a structural foam block and center ring for correct pad centering. It has a "shower feed" design for getting solution to the floor.

- Ref. No.:** 56505796 - Union Mix  
 56505794 - Prolene  
 56505792 - Dyna Grit  
 56505797 - MidGrit  
 56505790 - Short Trim Pad Holder  
 56505795 - ProLite  
 56505791 - Magna Grit  
 56505798 - MidLite Grit  
 56505793 - AgLite Grit

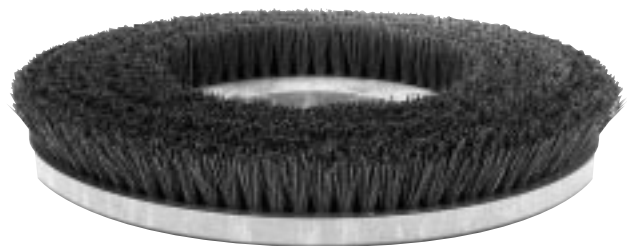

**DANMARK**

Nilfisk-Advance Nordic A/S  
 Myntevej 3, 8900 Randers  
 ☎ 86 42 84 33 – Fax 86 41 19 55

**NORGE**

Nilfisk-Advance AS  
 Enebakkn, 119, 0680 Oslo, Postboks 196, Manglerud,  
 0612 Oslo  
 ☎ 22 08 63 50 – Fax 22 08 63 63  
 Distriktsrepresentanter over hele landet

**SVERIGE**

Nilfisk-Advance AB  
 Sjöbjörnsvägen 5, 117 67 Stockholm  
 ☎ 085 55 944 00 – Fax 085 55 944 30

**FINLAND/ SUOMI**

Oy Tecalemit AB  
 Hankasuontie 13, 00390 Helsinki  
 ☎ (89) 547 701 – Fax (89) 547 1779

**AUSTRALIA**

Nilfisk-Advance Pty. Ltd.  
 ACN 003 762 623  
 Head office: 17 Leeds Street, Rhodes, N. S. W. 2138  
 ☎ (02) 9736 1244 – Fax (02) 9736 3910  
 Customer Responce Centre:  
 ☎ 1 800 011 013

**BELGIQUE / BELGIË/ LUXEMBOURG**

Nilfisk-Advance s.a./n.v.  
 Doornveld/ Sphere Business Park  
 Industrie Asse 3, nr 11 – bus 41  
 1731 Zellik-Asse  
 ☎ (02) 467.60.50 Fax (02) 463.44.16

**CANADA**

Nilfisk-Advance Ltd.  
 396 Watline Avenue  
 Mississauga, Ontario L4Z 1X  
 ☎ (905) 712-3260 – Fax (905) 712-3255

**DEUTSCHLAND**

Nilfisk-Advance AG  
 Siemensstraße 25-27  
 25462 Rellingen  
 ☎ (041 01) 3990 – Fax (04101) 399191  
 Zentraler Kundenservice  
 ☎ für die Industrie: 0180 535 67 97  
 ☎ Institutionen und Gebäudereiniger: 0180 500 11 70

**FRANCE**

Nilfisk-Advance S.A.  
 BP 246  
 91944 Courtaboeuf Cedex  
 ☎ (01) 69.59.87.00 Télécopie (01) 69.59.87.01

**HONG KONG**

Nilfisk-Advance Ltd.  
 2001, 20/F HK Worsted Mills  
 Industrial Building  
 31-39 Wo Tong Tsui Street  
 Kwai Chung, N.T.  
 ☎ 2427 59 51 – Fax 2487 5828

**IRELAND**

Nilfisk-Advance Ltd.  
 28 Sandyford Office Park  
 Dublin 18  
 ☎ +353 1 2943838 – Fax +353 1 2943845

**JAPAN**

Nilfisk-Advance Inc.  
 3-4-9 Chigasaki Minami  
 Tsuzuki-Ku Yokohama 224  
 ☎ 045-942-7741 – Fax 045-942-6545

**MALAYSIA**

Nilfisk-Advance Sdn Bhd  
 Lot 2, 1<sup>st</sup>. Floor  
 Lorong 19/1A  
 46300 Petaling Jaya  
 Selangor Darul Ehsan  
 ☎ 03-7568188 / 03-7568189 / 03-7568388 – Fax 03-7566828

**NEDERLAND**

Nilfisk-Advance B.V.  
 Flevolaan 7, Postbus 341  
 1380 AH Weesp  
 ☎ 0294-462121 – Fax 0294-430053

**NEW ZEALAND**

Nilfisk-Advance Limited  
 477 Great South Road, Penrose  
 Auckland  
 ☎ (09) 525 0092 – Fax (09) 525 6440

**SCHWEIZ / SUISSE**

Nilfisk-Advance AG  
 Ringstrasse 19, 9533 Kirchberg/Wil  
 ☎ 719 23 52 83 – Fax 719 23 84 44

**SINGAPORE**

Nilfisk-Advance Pte. Ltd.  
 10, Woodlands Loop  
 Singapore 738388  
 ☎ (65) 759 9100 – Fax (65) 759 9133

**TAIWAN**

Nilfisk-Advance Ltd.  
 1 F, No.23, Lane 132, Sec. 2  
 Ta An Road, Taipei  
 ☎ 700 22 68 – Fax 784 08 43

**UNITED KINGDOM**

Nilfisk-Advance Limited  
 Newmarket Road  
 Bury St. Edmunds  
 Suffolk IP 33 3SR  
 ☎ (01284) 763163 – Fax (01284) 750562

**USA**

Nilfisk-Advance Inc.  
 14600 21<sup>st</sup> Avenue North  
 Plymouth, MN 55447-3408  
 ☎ +1 800 989 2235 – Fax 1 800 989 6566

Nilfisk-Advance of America, Inc.  
 300 Technology Drive  
 Malvern, PA 19355  
 ☎ (610) 647 647-6427

**ÖSTERREICH**

Nilfisk-Advance GmbH  
 Vorarlberg Allee 46  
 1230 Wien  
 ☎ 1 616 58 30 – Fax 1 616 58 30 40

**ESPAÑA**

Nilfisk-Advance, S.A.  
 Torre D'Ara  
 Passeig del Rengle, 5 Pl.9-10  
 E-08302 – Mataró (Barcelona)  
 ☎ Tel. 93 741 24 00 – Fax: 93 757 80 20  
 Central atención al cliente: 902 200 201  
[nilfisk@nilfisk-advance.es](mailto:nilfisk@nilfisk-advance.es) – [www.nilfisk-advance.com](http://www.nilfisk-advance.com)  
 Distribuidores y Servicio Técnico en toda España y Andorra

**ITALIA**

Nilfisk-Advance Italia Spa  
 Località Novella Terza  
 26862 Guardamiglio (LO)  
 Italy  
 ☎ +39 0377 414021 – Fax +39 0377 414097  
[www.nilfisk-advance.com](http://www.nilfisk-advance.com)

**PORTUGAL**

Nilfisk-Advance Lda.  
 Rua Cândido de Figueiredo, 91-i, 1500-133 LISBOA  
 ☎ 01/7784142 – Fax 01/7785613  
 Porto 02/526766 – Fax 02/520739  
 Açores 096/628092/3 – Fax 096/628129  
 Madeira 091/228965 – Fax 091/228796

**GREECE**

Embiom S.A.  
 Λεωφ. Βουλιαγμένης 60  
 Αργυρούπολη  
 164 52 Αθήνα  
 ☎ 9950613 - Fax 9951680



