



# Electronic Service Manuals

This electronic document is provided as a service to our customers. We do not create the contents of the information contained in this document. Should you have detailed questions pertaining to the information contained in this document, you may contact Michco, or the manufacturer which provided the original information in this electronic deliverable. Michco's only part in this electronic deliverable was the electronic assembly process.

You may contact Michco through the following methods:  
Phone (517) 484-9312 or (800) 331-3339 MI, OH, IN only  
2011 N. High St. -- Lansing, Michigan -- 48906  
Fax: (517) 484-9836  
Email: [CustServ@Michco.com](mailto:CustServ@Michco.com)  
Web site: [www.Michco.Com](http://www.Michco.Com)  
Parts Web site: [www.FloorMachineParts.Com](http://www.FloorMachineParts.Com)

Order Parts on Line at:  
**[www.FloorMachineParts.Com](http://www.FloorMachineParts.Com)**

Directly to Parts & Service:  
By Email: **[Shop@Michco.com](mailto:Shop@Michco.com)**  
By Fax: (517) 702-2041  
By Voice: Use numbers above.

**Serving the Cleaning Industry Since 1922**

Notice: All copyrighted material remains property of original owners, all trademarks are property of respective owners. Manuals are subject to Manufacturer's reproduction limitations. Originals or reproductions were provided by manufacturers through a request. We make no warranty as to the correctness of information provided in this document and you assume all risk.

# Convertamatic™ 285LX

---

# Hydro-Retriever™ 285HD

---

# Lynx™ 285

---

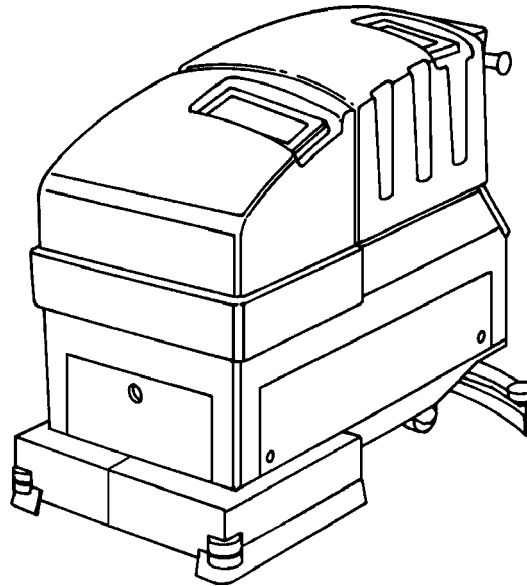

---

## **PARTS LIST**

**Advance MODELS 56391007(285LX)**

**56391008(285HD & Lynx)**

**All models covered in this manual are Obsolete.**

This parts list is for machines after serial number 488316

---



**Advance**  
*by Nilfisk-Advance*

revised 11/01 Form Number 56042273

# TABLE OF CONTENTS

<b>DESCRIPTION</b>	<b>PAGE</b>
Control Handle .....	1-2
Electrical Panel .....	3-4
Chassis - 285LX .....	5-6
Chassis - 285HD .....	7-8
Vacuum Motor .....	9-10
Drive System .....	11-12
Brush Drive Lift .....	13-14
Brush Drive .....	15-16
Recovery Tank - (before SN 498303) .....	17-18
Recovery Tank - (after SN 498302) .....	19-20
Solution Tank .....	21-22
Squeegee Mount .....	23-24
Squeegee - (before SN 603991) .....	25-26
Squeegee - (after SN 603990) .....	27-28
Wiring Diagram - (before Feb. 1993) .....	29-30
Wiring Diagram - (after Jan. 1993) .....	31-32

## WHEN ORDERING PARTS

- \* Use the 8 digit numbers from the "Ref. No." columns in this parts list.
- \* Specify the model and serial number of the machine.
- \* Use the space below to record the model and serial number for future reference.

Model \_\_\_\_\_ Serial No. \_\_\_\_\_

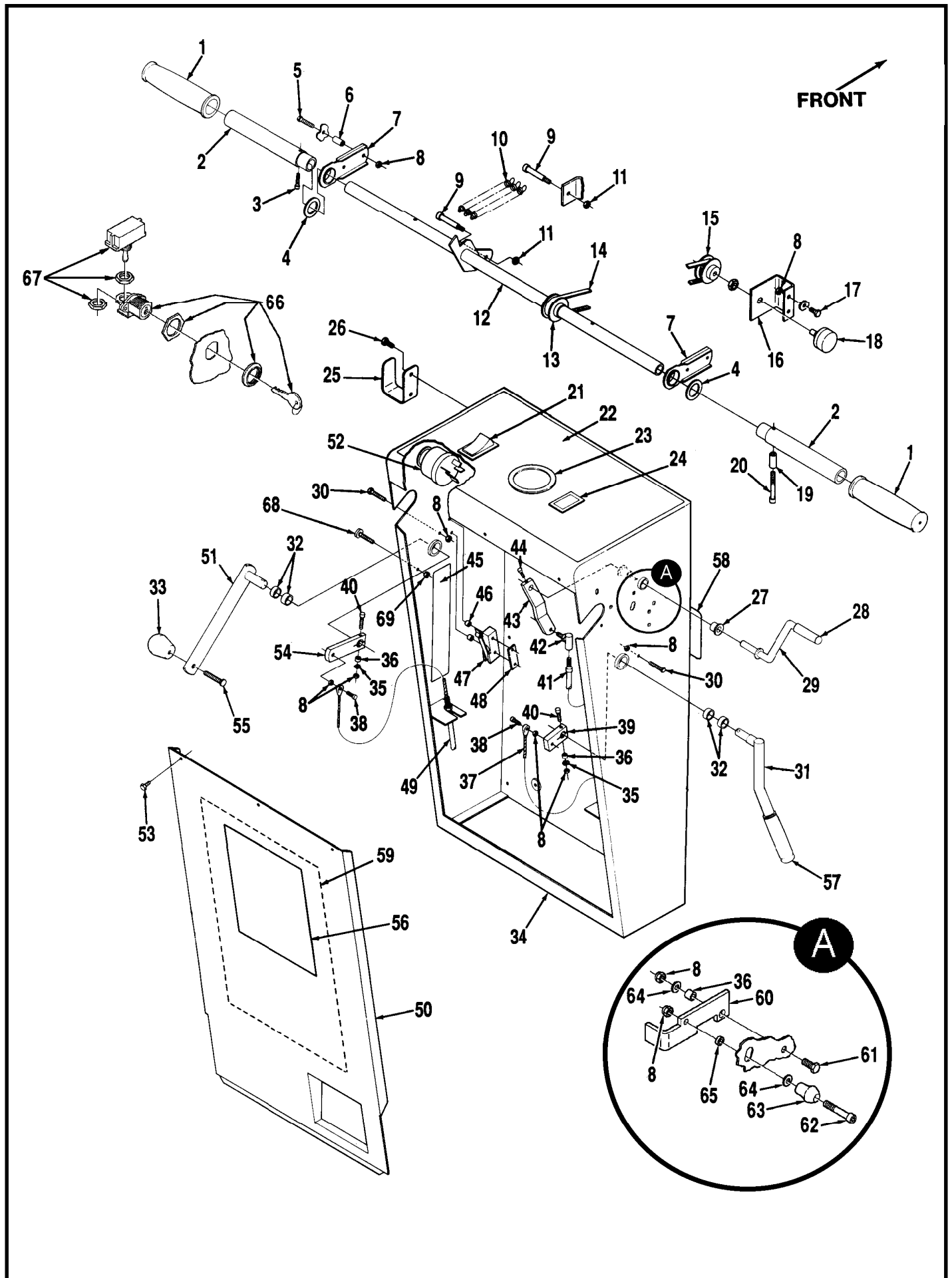

# CONTROL HANDLE

Item	Ref. No.	Qty	Description	Item	Ref. No.	Qty	Description
1	56388545	2	Hand Grip	37	56391306	1	Brake Cable
2	56261064	2	Tube	38	56002034	2	1/4-20 x 1 Cap Screw
3	56002179	1	#10-24 x 1 Cap Screw	39	56391504	1	Lever
4	56367192	2	Washer	40	56001961	2	1/4-20 x 1-1/4 Cap Screw
5	56001833	4	1/4-20 x 1-1/2 Screw	41	56488292	1	Solution Valve Cable
6	56261066	4	Bushing	42	56488290	1	Ball Joint
7	56261097	2	Bearing	43	56391494	1	Lever
8	56002708	14	1/4-20 Nut Nyloc	44	56002115	1	1/4-20 x 1/2 Cap Screw
9	56900481	2	Shoulder Screw	45	56025363	1	Decal, Caution
10	56358560	3	Spring	46	56369004	2	Bushing
11	56002768	2	#10-24 Nut Nyloc	47	56388019	1	Switch
12	56392733	1	Tube	48	56376015	1	Nut Plate
13	56392717	1	Pulley	49	56391305	1	Squeegee Cable
*	56002015	2	#10-24 x 1/4 Set Screw	50	56392078	1	Cover
14	56392721	1	Belt	51	56391496	1	Squeegee Lever
15	56324202	1	Pulley	52	56478640	1	Main Switch <b>Note #1</b>
*	56002279	2	#8-32 x 1/4 Set Screw		56478641	A/R	Replacement Key for 56478640
16	56392718	1	Bracket	53	56002518	3	#10-24 x 3/8 Screw HP-5
17	56001854	2	1/4-20 x 1/2 Screw	54	56391497	1	Lever
18	56454740	1	Potentiometer	55	56002667	1	5/16-18 x 3/4 Bolt
19	56475411	1	Bushing	56	56014601	1	Decal, Caution
20	56002454	1	#10-24 x 1-1/2 Cap Screw	57	56391311	1	Hand Grip
21	56377003	1	Switch	58	56014461	1	Decal, Cable Routing
22	56015362	1	Decal, Control Panel <b>Note #4</b>	59	56015187	1	Decal, Wiring <b>Note #4</b>
*	56015657	1	Decal, Control Panel <b>Note #5</b>	*	56015658	1	Decal, Wiring <b>Note #5</b>
23	56392668	1	Battery/Hour Meter <b>TSB568, TSB634</b>	60	56392091	1	Parking Brake Catch Lever <b>Note #3</b>
24	56467410	1	Indicator Light	61	56001836	1	1/4-20 x 5/8 Screw <b>Note #3</b>
25	56392765	1	Hook	62	56002242	1	1/4-20 x 1-1/2 Soc. Hd Screw <b>Note #3</b>
26	56002503	2	#10-24 x 1/2 Screw	63	56362426	1	Knob <b>Note #3</b>
27	56324505	2	Bearing	64	56002098	2	1/4 Flat Washer <b>Note #3</b>
28	56376486	1	Cap	65	56328758	1	Bushing <b>Note #3</b>
29	56391495	1	Solution Lever	66	56393325	1	Keylock Bracket <b>Note #2</b>
30	56001821	2	1/4-20 x 7/8 Screw		56393415	A/R	Replacement Key for 56393325
31	56391501	1	Brake Lever	67	56301636	1	Toggle Switch <b>Note #2</b>
32	56366633	4	Bearing	68	56002794	1	5/16-18 x 1 Bolt
33	56364527	1	Knob	69	56002826	1	5/16-18 Thin Nyl Loc Nut
34	56392723	1	Control Handle <b>Note #4</b>				
*	56392117	1	Control Handle <b>Note #5</b>				
35	56001803	2	1/4 Shakeproof Washer				
36	56379298	3	Bushing				

\* = Not Shown

**Note #1:** This part is used on machines before serial #0563278.**Note #2:** This part is used on machines after serial #0563277.**Note #3:** This part is used on machines after serial #0568435.**Note #4:** This part is used on machines before serial #1018020.**Note #5:** This part is used on machines after serial #1018019.

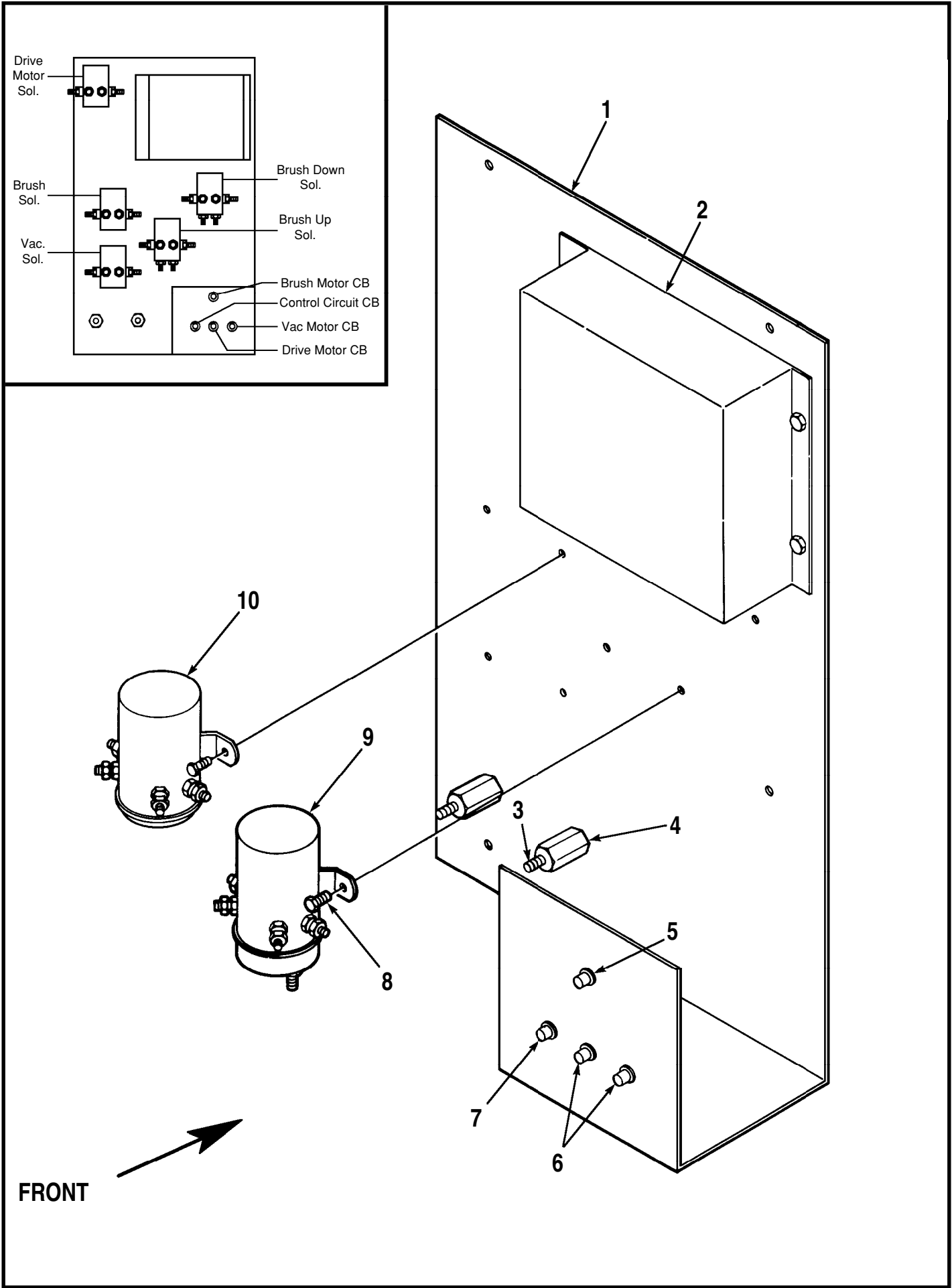

# ELECTRICAL PANEL

Item	Ref. No.	Qty	Description
1	56392678	1	Electrical Panel
2	56391210	1	Speed Control <b>TSB633, TSB635</b>
3	56454376	2	Stud
4	56469858	2	Stand-Off
5	56454429	1	70 Amp Circuit Breaker
6	56469788	2	25 Amp Circuit Breaker
7	56387328	1	5 Amp Circuit Breaker
8	56002530	8	1/4-20 x 3/8 HP-5 Screw
9	56388534	2	Solenoid
10	56395452	3	Solenoid
*	56391357	1	Time Delay <b>TSB632</b>

\* = Not Shown

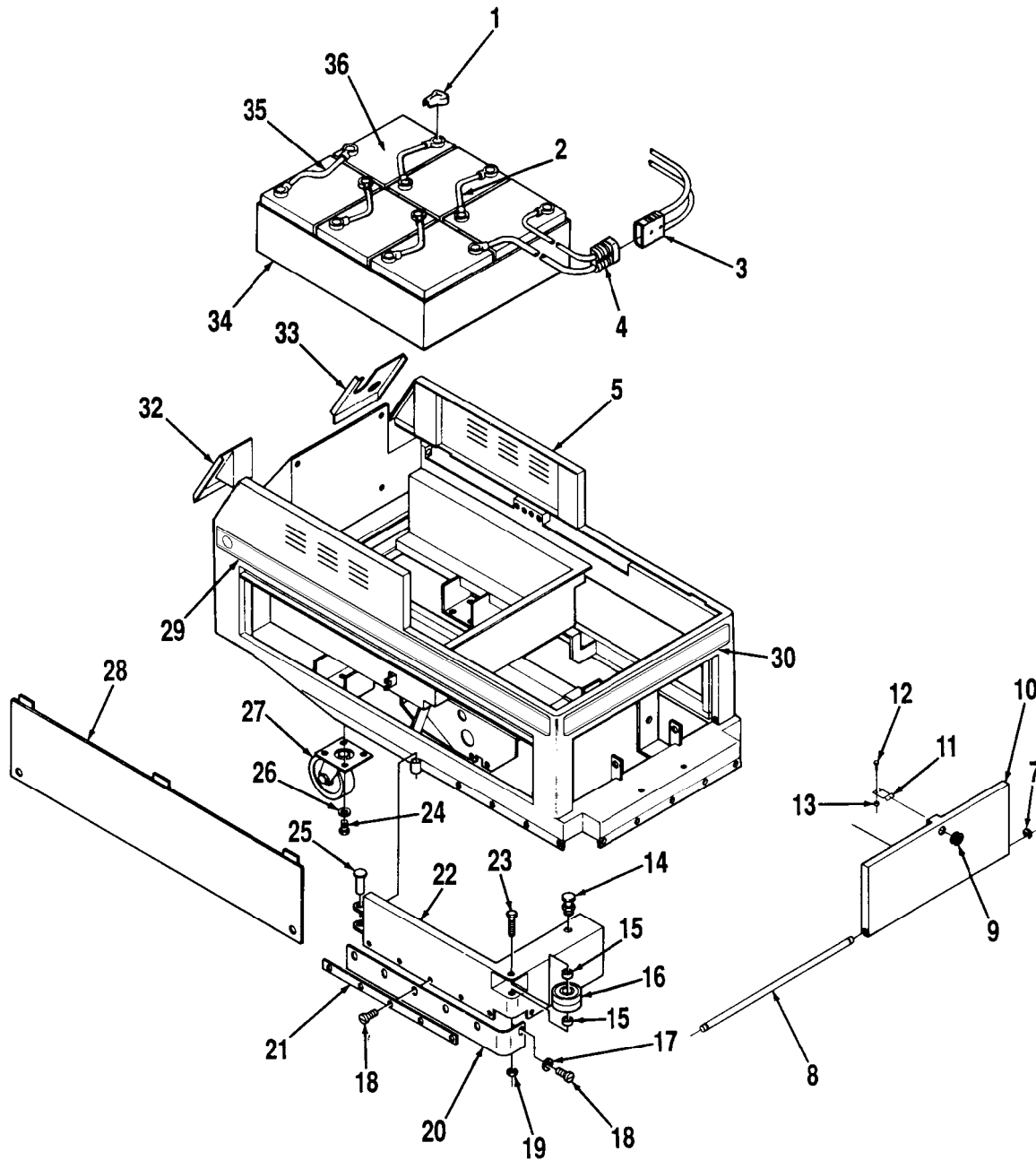

**Skirts after serial #0598325**

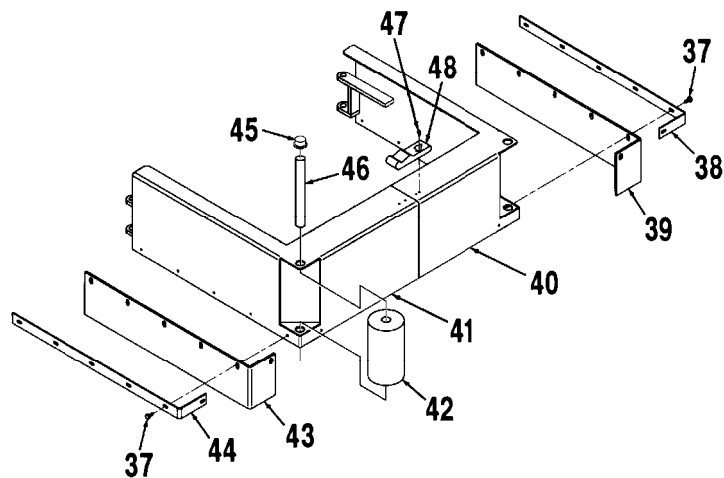

## LX CHASSIS

Item	Ref. No.	Qty	Description	Item	Ref. No.	Qty	Description
1	56372673	12	Battery Boot	28	56391838	2	Side Panel
2	56363928	4	Battery Cable	29	56015533	1	Decal, Stripe Right
3	56391161	1	Connector with Wires	*	56015534	1	Decal, Stripe Left
	56100622	1	Connector only <b>TSB633</b>	30	56015532	1	Decal, Front
*	56392241	1	Handle for Battery Connector	31			<b>Omitted Intentionally</b>
4	56261237	1	Connector with Wires	32	56392754	1	Right Rear Panel
	56100622	1	Connector only	33	56392727	1	Left Rear Panel
5	56391173	1	Chassis ( <b>before SN 0598326</b> )	34	56391248	1	Battery Tray ( <b>after SN 528000</b> )
			<b>Note #1</b>				<b>Note #1</b>
	56391344	1	Chassis ( <b>after SN 0598325</b> )		56261045	1	Battery Tray ( <b>before SN 529000</b> )
6			intentionally omitted				<b>Note #1</b>
7	56321427	2	Retaining Ring	35	56363936	1	Battery Cable
8	56391781	1	Rod	*	56391205	1	Main Wiring Harness <b>Note #2</b>
9	56344621	1	Grommet	*	56392119	1	Main Wiring Harness <b>Note #3</b>
10	56391782	1	Front Panel	36	56376014	6	Battery 244 Amp Hour **
11	56391776	1	Clip	*	56391391	6	Battery 305 Amp Hour **
12	56002504	2	#10-24 x 3/4 Screw	*	56372974	1	Automatic Battery Charger **
13	56369004	2	Bushing				
14	56578214	2	Lock				
15	56471220	4	Bushing				
16	56324499	4	Wheel				
17	56208874	2	Washer				
18	56372929	12	Screw				<b>Skirts after serial #0598325</b>
19	56002708	2	1/4-20 Nyloc Nut		56391322	1	Right Skirt Assembly
20	56391971	1	Right Blade		56391323	1	Left Skirt Assembly
*	56391972	1	Left Blade	37	56372929	12	Screw
21	56391919	1	Right Strap	38	56391318	1	Left Strap
*	56391918	1	Left Strap	39	56391321	1	Left Blade
22	56392716	1	Right Guard	40	56391347	1	Left Guard
	56392734	1	Right Skirt Assy ( <b>#14-23</b> )	41	56391348	1	Right Guard
*	56392715	1	Left Guard	42	56392102	2	Roller
*	56392735	1	Left Skirt Assy ( <b>#14-23</b> )	43	56391319	1	Right Blade
23	56001855	2	1/4-20 x 2-1/2 Screw	44	56391317	1	Right Strap
24	56002663	8	3/8-16 x 1 Bolt	45	56376544	2	Push Nut
25	56360147	2	Pin	46	56393372	2	Rod
*	56366633	4	Bushing	47	56570514	4	#6-32 x 3/8 HP-5 Screw
26	56002063	8	3/8 Flat Washer	48	56462316	1	Latch
27	56440450	2	Caster <b>Note #4</b>				
	56503007		Wheel for 56440450 Caster				
*	56391315	2	Caster Assembly <b>Note #4</b>				
*	56391320		Swivel Shock for 56391315 Caster				
*	56365742		Wheel for 56391315 Caster				

**Note #1:** After serial #528000, the chassis was widened to accept 305 AH batteries.

**Note #2:** This part is used on machines before serial #1018020.

**Note #3:** This part is used on machines after serial #1018019.

**Note #4:** All machines after serial #1018019 will come standard with a non shock caster (PN 56440450). The shock caster (PN56391315) will be a dealer installed option.

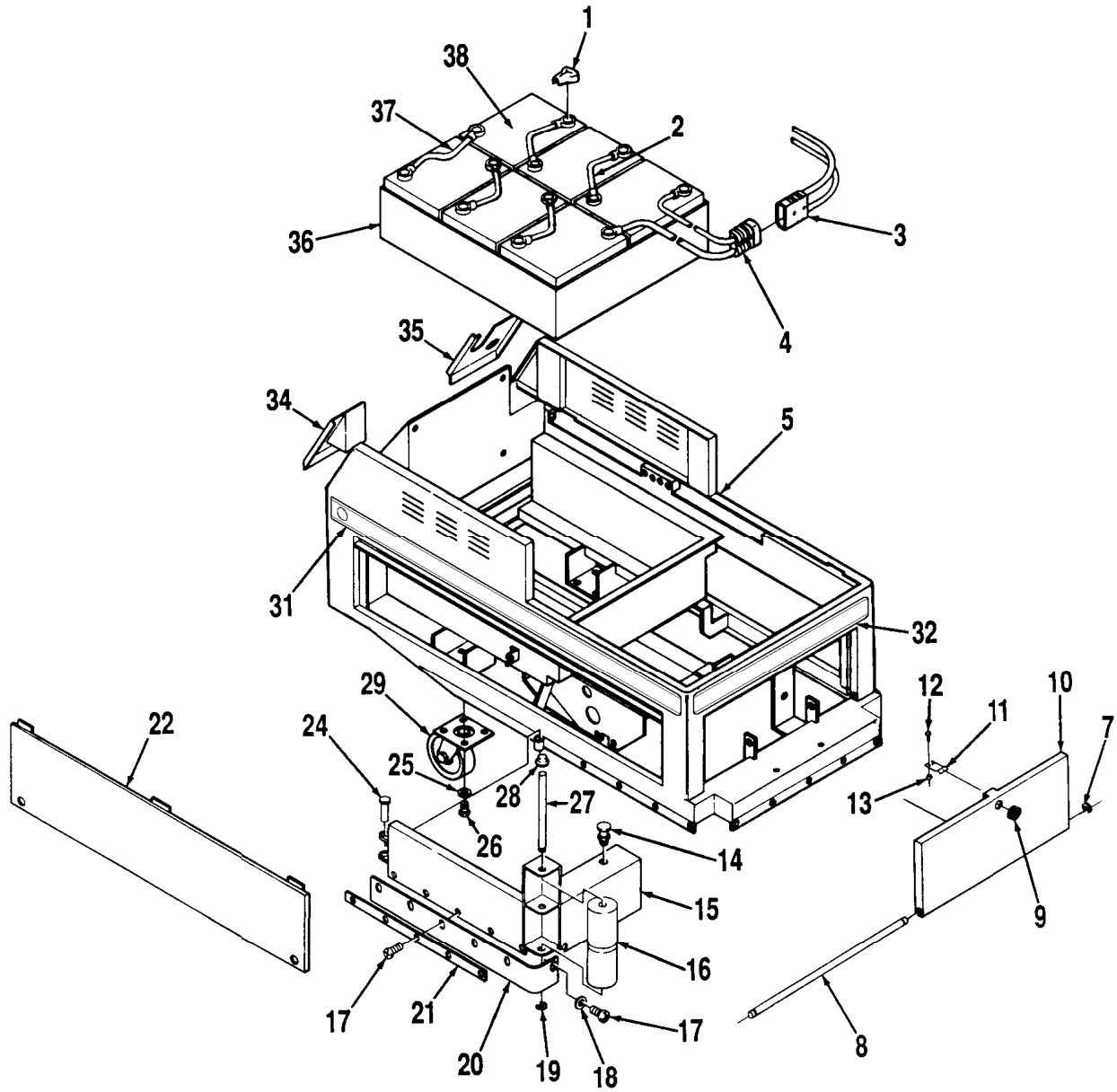

Skirts after serial #0598325

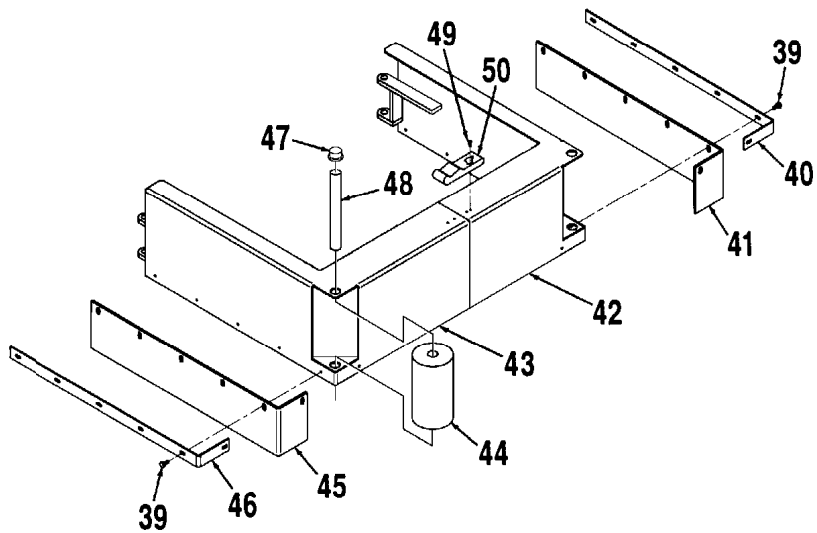

# HD CHASSIS

Item	Ref. No.	Qty	Description	Item	Ref. No.	Qty	Description
1	56372673	12	Battery Boot	30			Intentionally Omitted
2	56363928	4	Battery Cable	31	56015536	1	Decal, Stripe Right
3	56391161	1	Connector with Wires	*	56015537	1	Decal, Stripe Left
	56100622	1	Connector only <b>TSB633, G-1</b>	32	56015532	1	Decal, Front
*	56392241	1	Handle for Connector	33			<b>Omitted Intentionally</b>
4	56261237	1	Connector with Wires	34	56392754	1	Right Panel
	56100622	1	Connector only	35	56392727	1	Left Panel
5	56391173	1	Chassis ( <b>before SN 0598326</b> )	36	56391248	1	Battery Tray ( <b>after SN 528000</b> )
			<b>Note #1</b>				<b>Note #1</b>
	56391344	1	Chassis ( <b>after SN 0598325</b> )		56261045	1	Battery Tray ( <b>before SN 529000</b> )
6			Intentionally Omitted				<b>Note #1</b>
7	56321427	2	Retaining Ring	37	56363936	1	Battery Cable
8	56391781	1	Rod	*	56391205	1	Main Wiring Harness <b>Note #2</b>
9	56344621	1	Grommet	*	56392119	1	Main Wiring Harness <b>Note #3</b>
10	56391782	1	Front Panel	38	56376014	6	Battery 244 Amp Hour **
11	56391776	1	Clip	*	56391391	6	Battery 305 Amp Hour **
12	56002504	2	#10-24 x 3/4 Screw	*	56372974	1	Automatic Battery Charger **
13	56369004	2	Bushing				
14	56578214	2	Lock				
15	56391916	1	Right Guard				
*	56391917	1	Left Guard				
16	56376540	4	Roller				<b>Skirts after serial #0598325</b>
*	56111503	8	Bearing				
17	56372929	12	Screw		56391322	1	Right Skirt Assembly
18	56203874	2	Washer		56391323	1	Left Skirt Assembly
19	56468834	2	Retaining Ring	39	56372929	12	Screw
20	56391971	1	Right Blade	40	56391318	1	Left Strap
	56391955	1	Right Skirt Assy ( <b>#14-21,27,28</b> )	41	56391321	1	Left Blade
*	56391972	1	Left Blade	42	56391347	1	Left Guard
*	56391954	1	Left Skirt Assy ( <b>#14-21,27,28</b> )	43	56391348	1	Right Guard
21	56391919	1	Right Strap	44	56392102	2	Roller
*	56391918	1	Left Strap	45	56391319	1	Right Blade
22	56391838	2	Side Panel	46	56391317	1	Right Strap
23			Intentionally Omitted	47	56376544	2	Push Nut
24	56360147	2	Pin	48	56393372	2	Rod
*	56366633	4	Bushing	49	56570514	4	#6-32 x 3/8 HP-5 Screw
25	56002063	8	3/8 Flat Washer	50	56462316	1	Latch
26	56002663	8	3/8-16 x 1 Bolt				
27	56391926	2	Pin				
28	56376544	2	Cap				
29	56440450	2	Caster <b>Note #4</b>				
	56503007		Wheel for 56440450 Caster				
*	56391315	2	Caster Assembly <b>Note #4</b>				
*	56391320		Swivel Shock for 56391315 Caster				
*	56365742		Wheel for 56391315 Caster				

\* = Not Shown  
 \*\* = Not Included

**Note #1:** After serial #528000, the chassis was widened to accept 305 AH batteries.  
**Note #2:** This part is used on machines before serial #1018020.  
**Note #3:** This part is used on machines after serial #1018019.  
**Note #4:** All machines after serial #1018019 will come standard with a non shock caster (PN 56440450). The shock caster (PN 56391315) will be a dealer installed option.

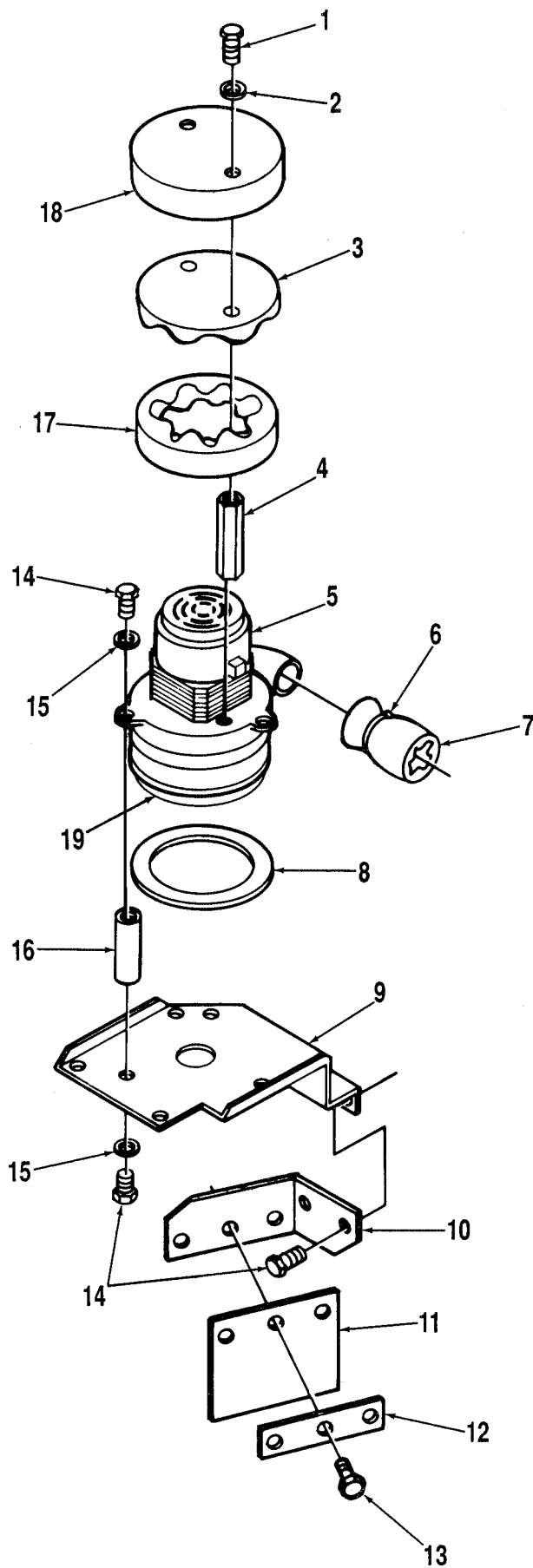

FRONT  
↘

## VACUUM MOTOR

Item	Ref. No.	Qty	Description
	56392674	1	Vacuum Motor Assembly (#1-8,14-17)
1	56002589	2	#6-32 x 3/8 Screw
2	56002006	2	#6 Flat Washer
3	56391808	1	Foam
4	56391795	2	Stand-Off
5	56391208	1	Vacuum Motor
*	56377001	1	Carbon Brushes for Vacuum Motor
6	56477612	1	Cable Tie
7	56391807	1	Foam
8	56385437	1	Gasket
9	56391786	1	Motor Mount
10	56391760	1	Bracket
11	56391307	1	Blade
12	56391761	1	Strap
13	56002503	3	#10-24 x 1/2 Screw
14	56001861	8	1/4-20 x 3/8 Screw
15	56002098	6	1/4 Flat Washer
16	56377474	3	Stand-Off
17	56391809	1	Foam
18	56391794	1	Cover
19	56384898	1	Filter

\* = Not Shown



## DRIVE SYSTEM

Item	Ref. No.	Qty	Description
1	56391536	2	Pillow Block
2	56378380	2	Bearing
3	56344362	1	Grease Fitting
4	56376628	1	Wheel
	56391538	1	Wheel and Axle Assembly (#2-9)
5	56391534	1	Axle
6	56388700	1	Sprocket
7	56391539	6	Bushing
8	56391537	1	Brake Disc
9	56002426	6	5/16-18 x 2-1/2 Bolt
10	56002127	4	3/8-16 x 3/4 Bolt
11	56002769	4	3/8-16 Nut Nyloc
12	56391301	1	Brake Caliper
13	56002768	1	#10-24 Nut Nyloc
14	56375334	1	Bushing
15	56391310	1	Chain
16	56002425	1	#10-24 x 7/8 Screw
17	56391306	1	Cable
18	56001954	1	#10 Flat Washer
19	56471148	1	Sprocket
20	56367958	1	3/16 x 1-1/8 Key
21	56002663	4	3/8-16 x 1 Bolt
22	56111503	2	Bearing
23	56391530	1	Motor Mount
24	56391535	1	Pillow Block
25	56388585	1	Drive Motor
*	56388586	1	Carbon Brushes for Drive Motor

\* = Not Shown

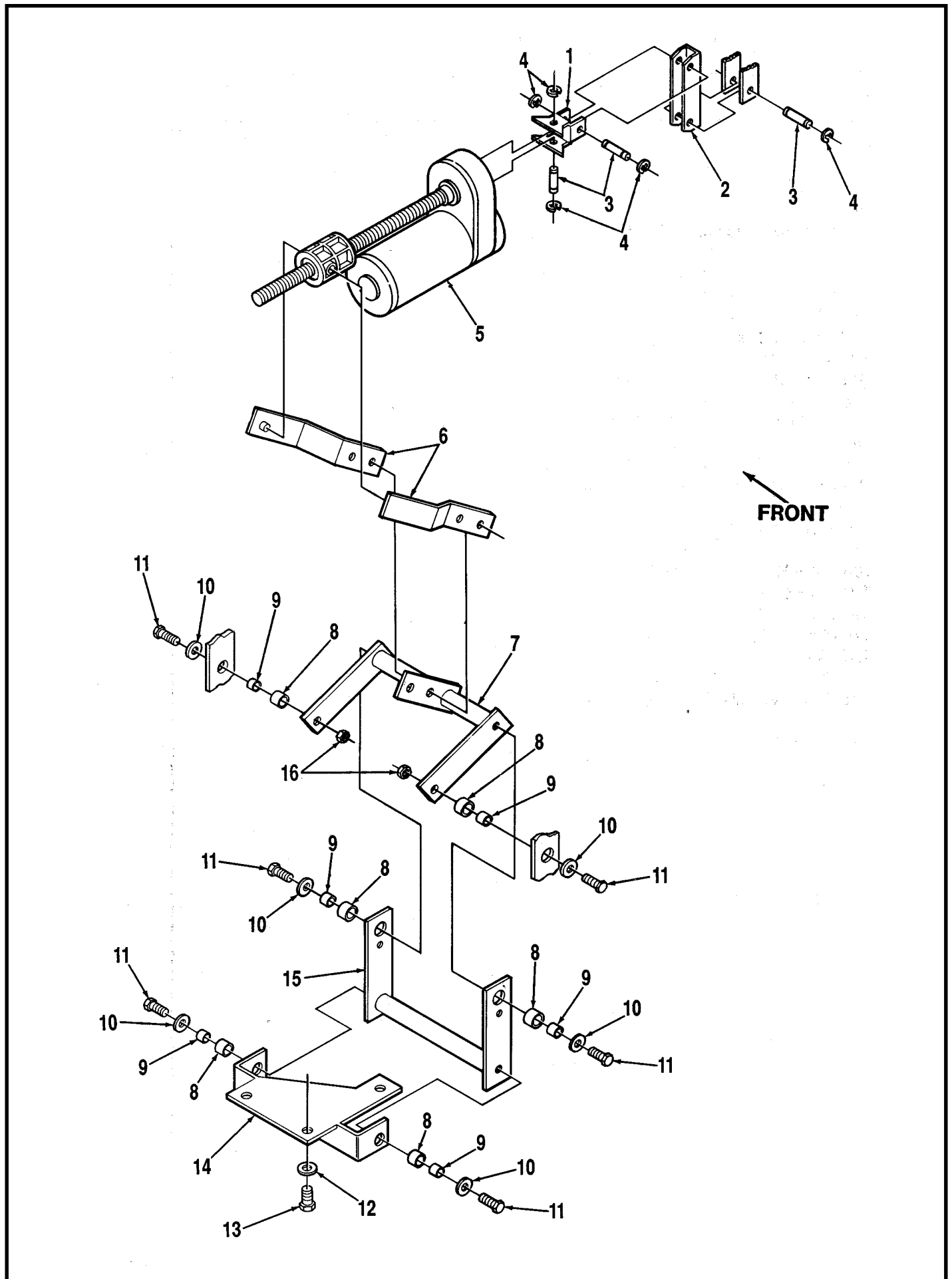

# BRUSH LIFT

Item	Ref. No.	Qty	Description
	56391628	1	Gear Motor Assembly (#1-5)
1	56392454	1	Yoke
2	56391626	1	Swing Arm
3	56104760	3	Pin
4	56321427	6	Retaining Ring
5	56391627	1	Actuator
*	56470431	1	Carbon Brush Kit (for 56391627)
	56388520	1	Plastic Nut for Actuator
6	56391590	2	Lever
7	56391577	1	Lever
8	56185263	6	Bearing
9	56391840	6	Bushing
10	56152781	6	Washer
11	56002667	6	5/16-18 x 3/4 Bolt
12	56002063	3	3/8 Flat Washer
13	56002127	3	3/8-16 x 3/4 Bolt
14	56391593	1	Bracket
15	56391587	1	Lifter Yoke
16	56002701	2	5/16-18 Nut Nyloc

\* = Not Shown

FRONT

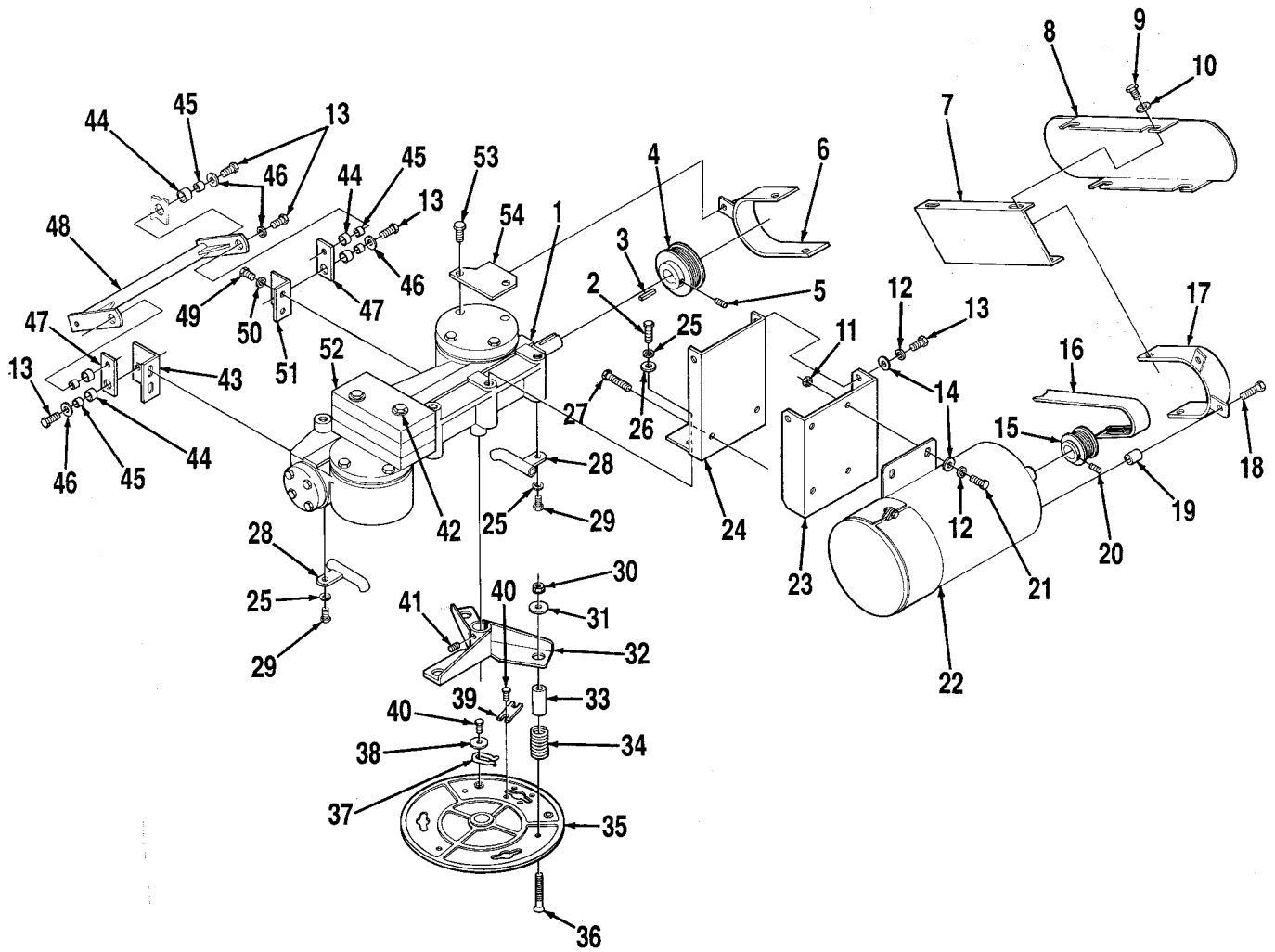

## BRUSH DRIVE

Item	Ref. No.	Qty	Description	Item	Ref. No.	Qty	Description
1	56391570	1	Gear Box Assy <b>TSB 614</b>	31	56752278	6	Washer
2	56002663	2	3/8-16 x 1 Bolt	32	56391621	2	Drive Adapter (3/4" Dia. Shafts)
3	56367958	1	Key ( <b>before serial #0592373</b> )		56392396	2	Drive Adapter (1" Dia. Shafts)
	56378704	1	Key ( <b>after serial #0592372</b> )	33	56392530	6	Spacer
4	56372889	1	Sheave ( <b>before serial #0592373</b> )	34	56392513	6	Spring
	56372891	1	Sheave ( <b>after serial #0592372</b> )	35	56391611	2	Brush Holder
5	56001826	2	5/16-18 x 1/2 Set Screw	**	56505774	2	Prolene Scrub Brush
6	56391770	1	Bracket	**	56505770	2	Pad Holder
7	56391763	1	Belt Guard	**	56505772	2	Dyna-Grit 80 Brush
8	56391764	1	Belt Guard	**	56505771	2	Magna-Grit 46 Brush
9	56002504	4	#10-24 x 1-3/4 Screw	**	56505773	2	AgLite Grit 500 Brush
10	56001954	4	#10 Flat Washer	**	56505775	2	Prolite Brush
11	56002701	6	5/16-18 Nut Nyloc	**	56505776	2	Union Mix Brush
12	56001905	6	5/16 Shakeproof Washer	36	56900139	6	Bolt
13	56002667	8	5/16-18 x 3/4 Bolt	37	56366463	2	Retaining Spring
14	56001939	6	5/16 Flat Washer	38	56151114	2	Washer
15	56391610	1	Sheave	39	56366455	2	Plate
16	56756048	1	Belt	40	56002834	6	#10-24 x 3/8 Screw
17	56391767	1	Bracket	41	56001958	2	3/8-16 x 3/8 Set Screw
18	56001878	2	1/4-20 x 1-1/4 Screw	42	56249164	2	Screw
19	56391766	2	Spacer	*	56180200	2	Washer
20	56002021	2	5/16-18 x 3/8 Set Screw	43	56391952	1	Left Bracket
21	56002221	4	5/16-18 x 1 Bolt	44	56185263	6	Bearing
22	56391314	1	Brush Motor	45	56391840	6	Bushing
*	56448729	1	Carbon Brushes for Brush Motor	46	56152781	6	Washer
23	56391598	1	Channel	47	56391586	2	Lever
24	56391599	1	Bracket ( <b>before serial #0592373</b> )	48	56391581	1	Torsion Bar
	56391353	1	Bracket ( <b>after serial #0592372</b> )	49	56002659	4	1/2-13 x 7/8 Bolt
*	56469858	2	Insulated Stand-Off	50	56001991	4	1/2 Shakeproof Washer
*	56150274	2	Stud	51	56391953	1	Right Bracket
25	56002206	2	3/8 Shakeproof Washer	52	56391839	3	Weight
26	56002063	2	3/8 Flat Washer	53	56366285	20	Screw
27	56002095	2	3/8-16 x 1-1/2 Bolt	54	56391765	1	Bracket
28	56391604	2	Solution Pipe				
29	56002127	2	3/8-16 x 3/4 Bolt				
30	56759062	6	Nut				

\* = Not Shown

\*\* = Optional Accessory, Not Included

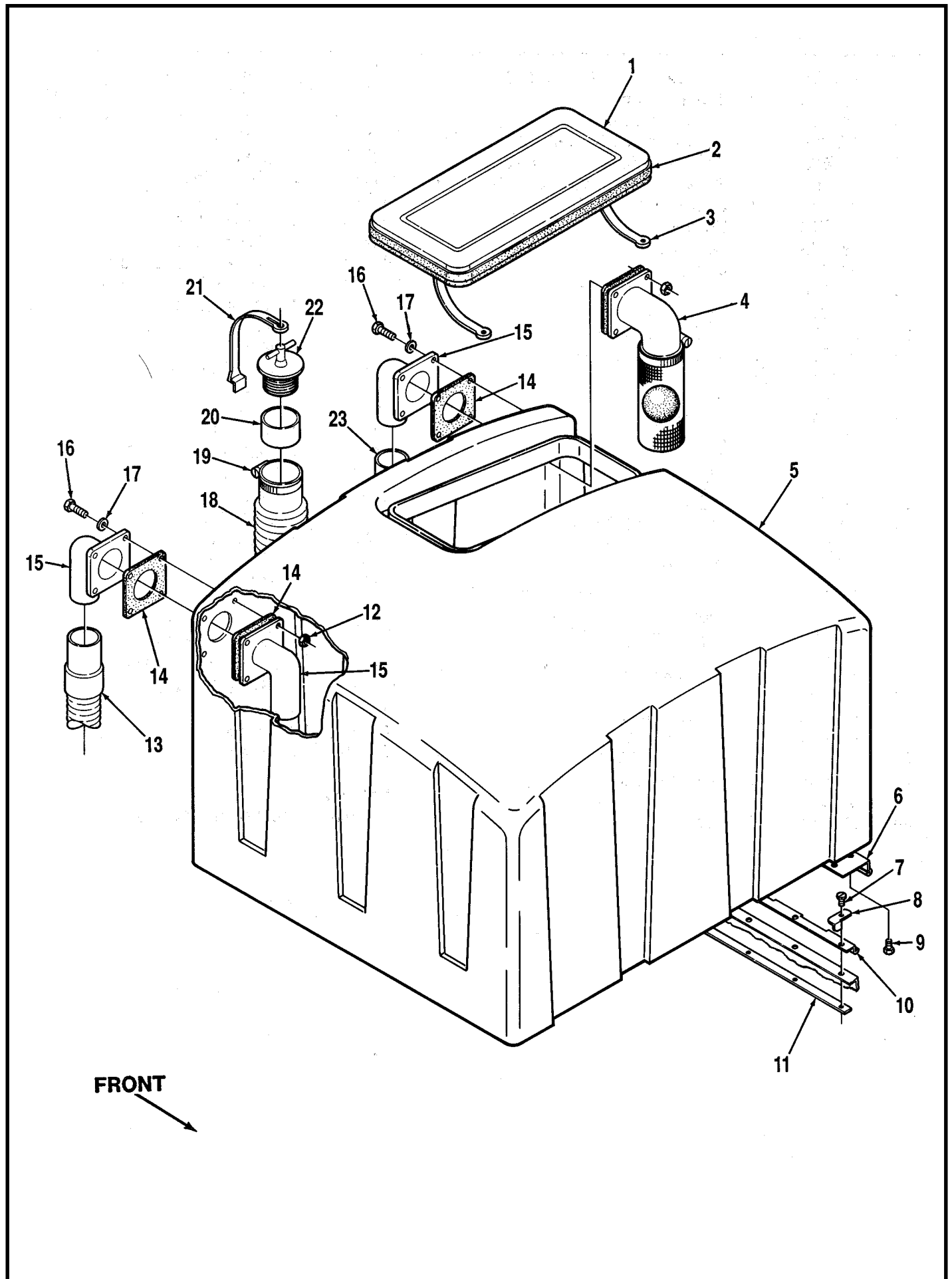

## RECOVERY TANK (before SN0498303)

Item	Ref. No.	Qty	Description
	56392699	1	Recovery Tank Assembly (#1-6,12,14-17)
1	56261395	1	Cover
	56261393	1	Cover Assembly (#1,3) - See pages 19-20 for Cover Assembly Update.
2	56261390	1	Gasket
3	56263379	2	Strap
4	56391690	1	Float Ball - See pages 19-20 for Float Assembly Update.
	56391691	1	Float Cage
5	56391230	1	Recovery Tank
6	56392677	1	Hinge
7	56002829	6	#10-24 x 5/8 Screw
8	56381053	2	Clip
9	56001861	11	1/4-20 x 3/8 Screw
10	56391181	1	Hinge
11	56392676	1	Nut Plate
12	56002836	8	#10-24 Stainless Steel Nyloc Nut
13	56392662	1	Squeegee Hose
14	56391644	2	Gasket
15	56392666	3	Hose Adapter
16	56002837	8	#10-24 x 1 Stainless Steel Screw
17	56002916	8	#10 Stainless Steel Flat Washer
18	56392590	1	Drain Hose
19	56329145	3	Hose Clamp
20	56459250	1	Cuff
21	56261378	1	Strap
22	56459253	1	T-Plug
23	56392660	1	Vacuum Hose
*	56392756	2	Support Bracket
*	56263842	2	Plate

\* = Not Shown

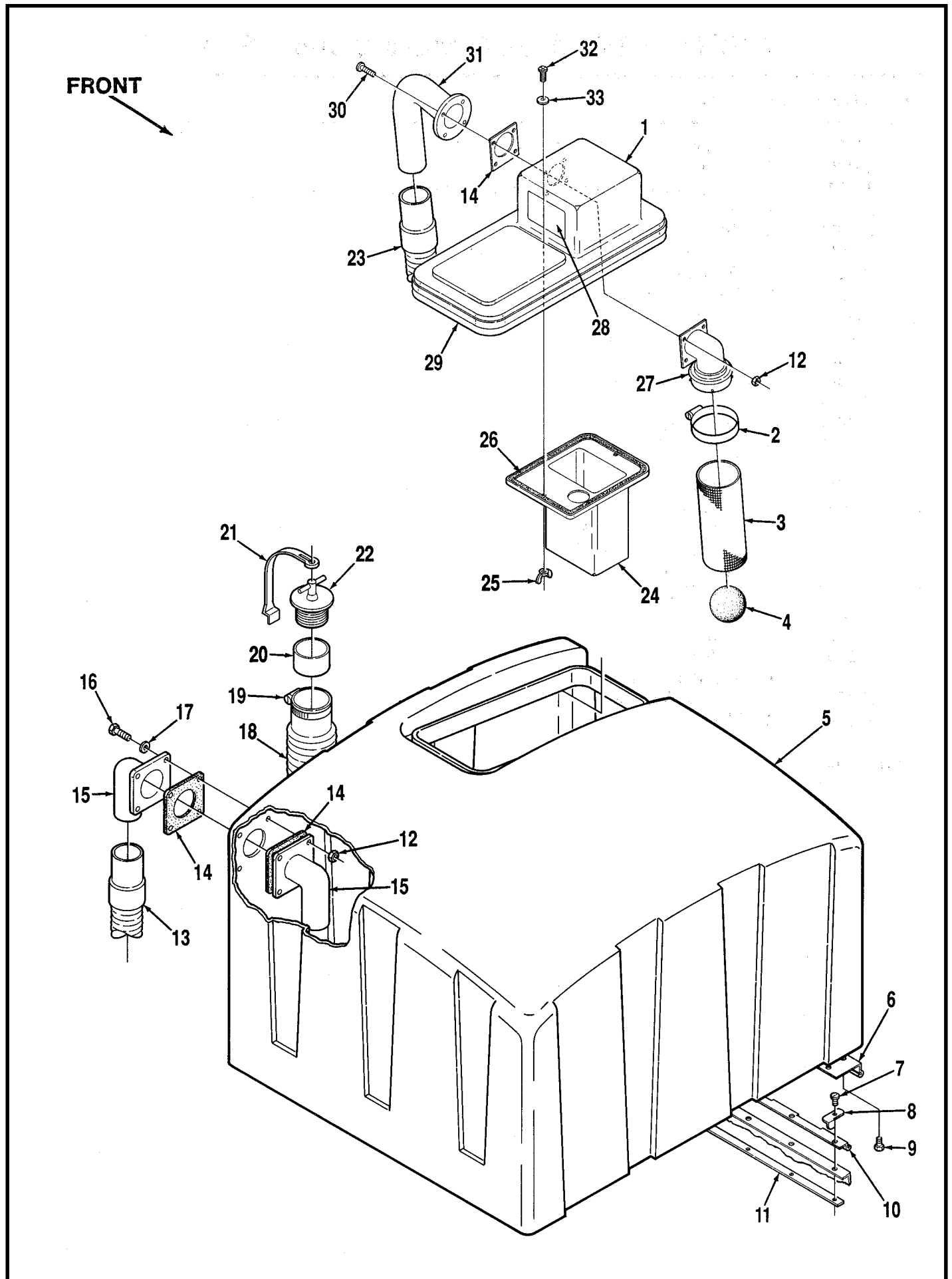

## RECOVERY TANK (after SN0498302)

Item	Ref. No.	Qty	Description
	56392699	1	Recovery Tank Assembly (#5, 6, 12, 14-17)
1	56392589	1	Cover
	56392584	1	Cover Assembly (#1-4, 12, 14, 24-33)
2	56440213	1	Hose Clamp
3	56391691	1	Float Cage
4	56391690	1	Float Ball
5	56391230	1	Recovery Tank
6	56392677	1	Hinge
7	56002829	6	#10-24 x 5/8 Screw
8	56381053	2	Clip
9	56001861	11	1/4-20 x 3/8 Screw
10	56391181	1	Hinge
11	56392676	1	Nut Plate
12	56002836	8	#10-24 Nyloc Nut
13	56392662	1	Squeegee Hose
14	56391644	3	Gasket
15	56392666	2	Hose Adapter
16	56002837	8	#10-24 x 1 Stainless Steel Screw
17	56002916	8	#10 Stainless Steel Flat Washer
18	56392590	1	Drain Hose
19	56329145	3	Hose Clamp
20	56459250	1	Cuff
21	56261378	1	Strap
22	56459253	1	T-Plug
23	56392660	1	Vacuum Hose
24	56392591	1	Float Box
25	56392602	2	#8-32 Stainless Steel Wing Nut
26	56325324	2'	Gasket (62 cm)
27	56324309	1	Elbow
28	56015411	1	Decal, Important
29	56392079	1	Gasket
30	56002898	4	#10-24 x 1 Stainless Steel Pan Head Screw
31	56392587	1	Tube
32	56002895	2	#8-32 x 3/4 Stainless Steel Pan Head Screw
33	56257508	2	Sealing Washer
*	56392756	2	Support Bracket
*	56263842	2	Plate

\* = Not Shown

**Note:** Machines before SN0498303 can be updated as shown by ordering Float Update Kit, PN 56392592.

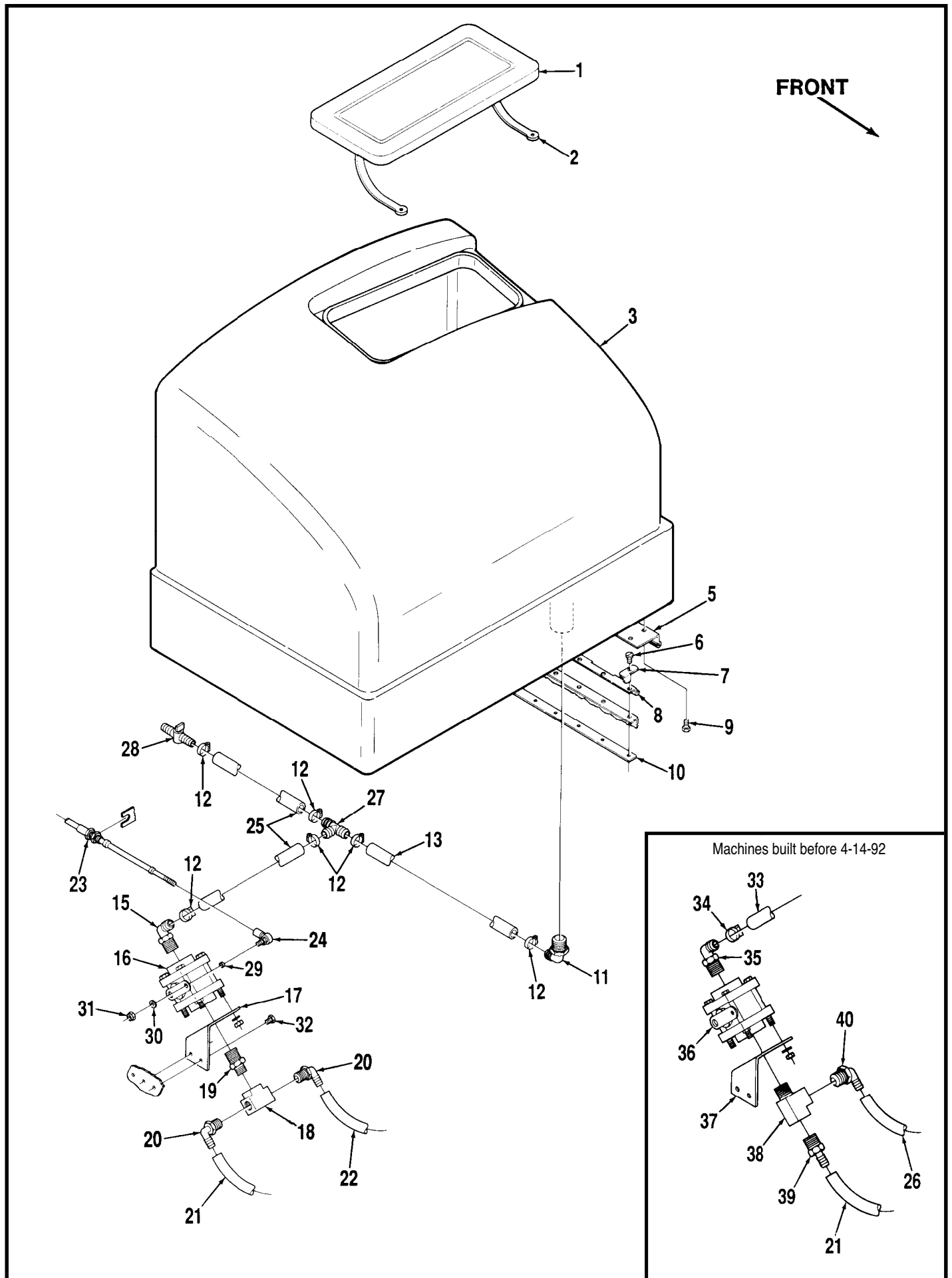

# SOLUTION TANK

Item	Ref. No.	Qty	Description
1	56261381	1	Cover
	56395916	1	Cover Assembly (#1-2)
2	56263379	2	Strap
3	56391231	1	Solution Tank
	56392698	1	Solution Tank Assembly (#1-3, 5, 9, 11)
4			<b>Omitted Intentionally</b>
5	56392669	1	Hinge
6	56002829	5	#10-24 x 5/8 Screw
7	56381053	2	Clip
8	56391189	1	Hinge
9	56001861	8	1/4-20 x 3/8 Screw
10	56392675	1	Nut Plate
11	56324035	1	Barb
12	56219932	6	Hose Clamp
13	56261263	1	Solution Hose
14			<b>Omitted Intentionally</b>
15	56391678	1	Barb
16	56391681	1	Solution Valve
	56391675	1	Solution Valve Assembly (#15-20)
17	56391676	1	Valve Mount
18	56900291	1	Tee
19	56900639	1	Reducer
20	56900035	2	Barb
21	56249682	1	Solution Hose (12 inches)
22	56391771	1	Solution Hose (21 inches)
23	56488292	1	Cable
24	56488290	1	Ball Joint
25	56386182	2	Hose
26	56391773	1	Solution Hose (24 inches)
27	56262549	1	Tee
28	56391243	1	Valve
29	56375334	1	Bushing
30	56001954	1	#10 Flat Washer
31	56002873	1	#10-32 Nyloc Nut
32	56002530	2	1/4-20 x 3/8 HP-5 Screw
<b>Machines built before 4-14-92</b>			
33	56392663	1	Hose
34	56219932	2	Hose Clamp
35	56391698	1	Barb
36	56391681	1	Solution Valve
37	56391676	1	Valve Mount
38	56749319	1	Tee
39	56391680	1	Barb
40	56391679	1	Barb

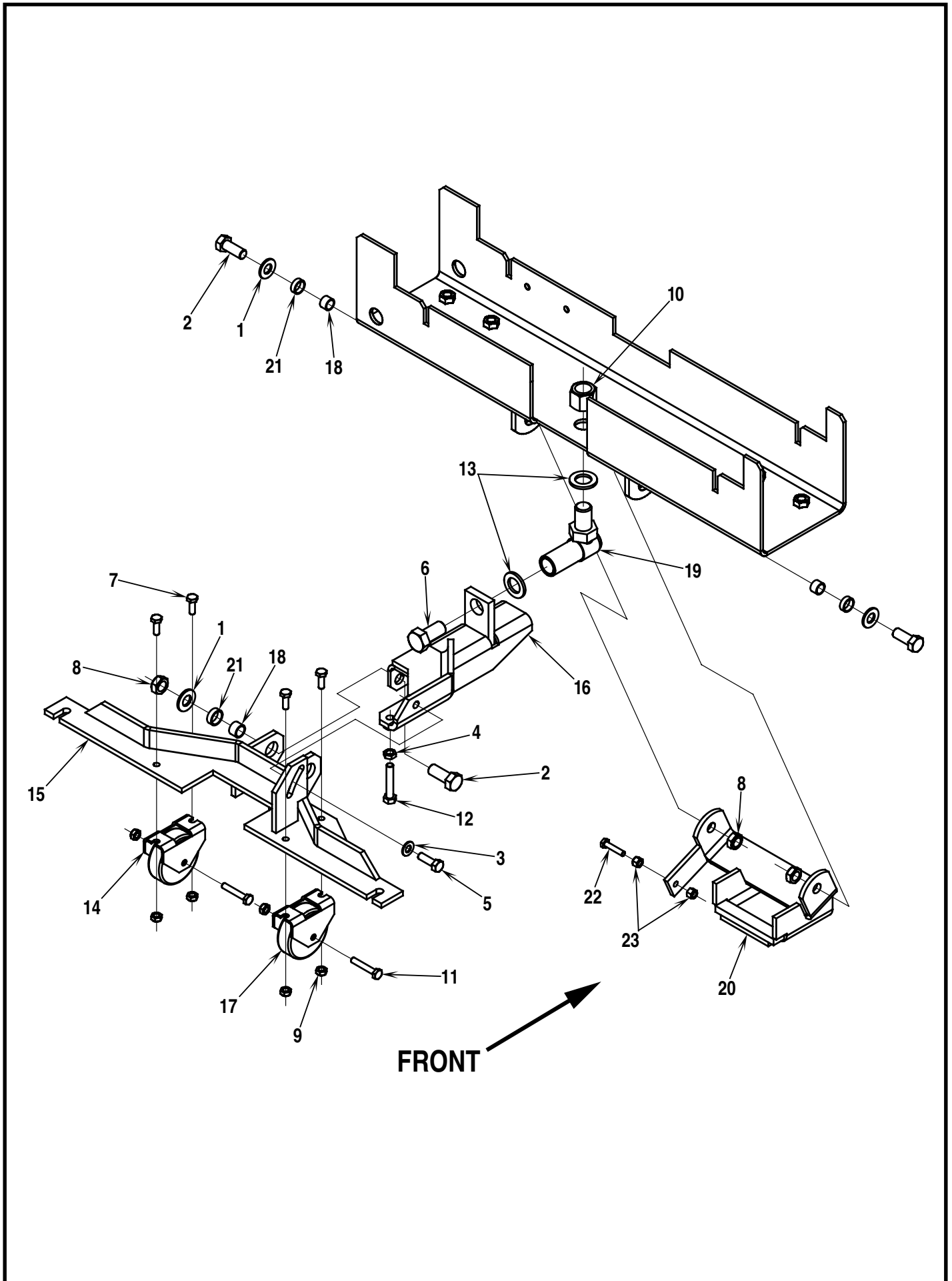

## SQUEEGEE MOUNT

Item	Ref. No.	Qty	Description
	56392218	1	Squeegee Mount Assembly (#1-19 & 21) <b>NOTE</b>
1	56001879	4	Wsh, Flt SAE 1/2
2	56001931	4	Scr, Hex Hd 1/2-13 x 1.25
3	56001939	1	Wsh, Flt SAE 5/16
4	56002025	1	Nut, Hex Jam 5/16-18
5	56002221	1	Scr, Hex Hd 5/16-18 x 1.00
6	56002739	1	Scr, Hex Hd 3/4-16 x 1.25
7	56002807	4	Scr, Hex Hd SS 1/4-20 x .75
8	56002843	4	Nut, Hex Nyl Loc-Thin 1/2-13
9	56002850	6	Nut, Hex Nyl Loc-Thin SS 1/4-20
10	56002863	1	Nut, Hex Nyl Loc 3/4-16
11	56002901	2	Scr, Hex Hd SS 1/4-20 x 1.50
12	56003005	1	Scr, Hex Hd 5/16-18 x 1.75
13	56009022	2	Wsh, Flt .75 x 1.25 x .12
14	56392217	2	Wheel Bracket
15	56262679	1	Squeegee Mount <b>TSB 655, TSB 668</b>
16	56262677	1	Squeegee Tongue Weld't <b>TSB 668</b>
17	56324515	2	Wheel <b>TSB 655</b>
18	56360627	4	Bushing
19	56391864	1	Ball Joint
20	56391860	1	Lifter Weld't
21	56478781	4	Bearing, Sleeve
22	56001878	1	Scr, Hex Hd 1/4-20 x 1.25
23	56002708	2	Nut, Hex Nyl Loc 1/4-20
*	56391305	1	Cable, Squeegee Lift <b>TSB 581</b>
*	56391674	1	Cable Bracket

\* = Not Shown

**NOTE:** The original Squeegee Mount Assembly PN 56392665 is obsolete and no longer available. Squeegee Mount Assembly PN 56392218 will directly replace the original assembly. The individual parts are not direct replacements, the entire assembly needs to be replaced.



## SQUEEGEE (before SN0603991)

Item	Ref. No.	Qty	Description
	56391211	1	Squeegee (#1-21)
1	56391212	1	Squeegee Tool
2	56370711	2	Thumb Nut
3	56002938	2	5/16 Flat Washer
4	56391218	2	Roller <b>NOTE</b>
5	56003007	4	#8-32 x 3/8 Screw
6	56391216	1	Outer Strap
7	56391250	1	Std. Gum Rubber Blade Kit
a	56391213	1	Front Blade
b	56391192	1	Main Wiping Blade, Gum Rubber
c	56391261	1	Back Up Blade
*	56391251	1	Opt. Oil Resistant Blade Kit
a	56391213	1	Front Blade
b	56391252	1	Main Wiping Blade, Neoprene
8	56157060	2	Retaining Ring
9	56391215	1	Strap
10	56002589	2	#6-32 x 3/8 Screw
11	56002006	2	#6 Flat Washer
12	56002907	2	#6-32 Stainless Steel Nyloc Nut
13	56471194	1	Latch
14	56391214	1	Strap
15	56201677	2	Wing Nut
16	56391217	2	Tab
17	56002491	7	1/4-20 Stainless Steel Nyloc Nut
18	56002859	7	1/4 Stainless Steel Flat Washer
19	56324499	2	Wheel
20	56371009	4	Washer

\* = Not Shown

**NOTE:** If replacing original Squeegee Mount Assembly PN 56392665 with the new Mount Assembly PN 56392218, remove the squeegee rollers from the squeegee. The new Squeegee Mount Assembly PN 56392218 has built in rollers.

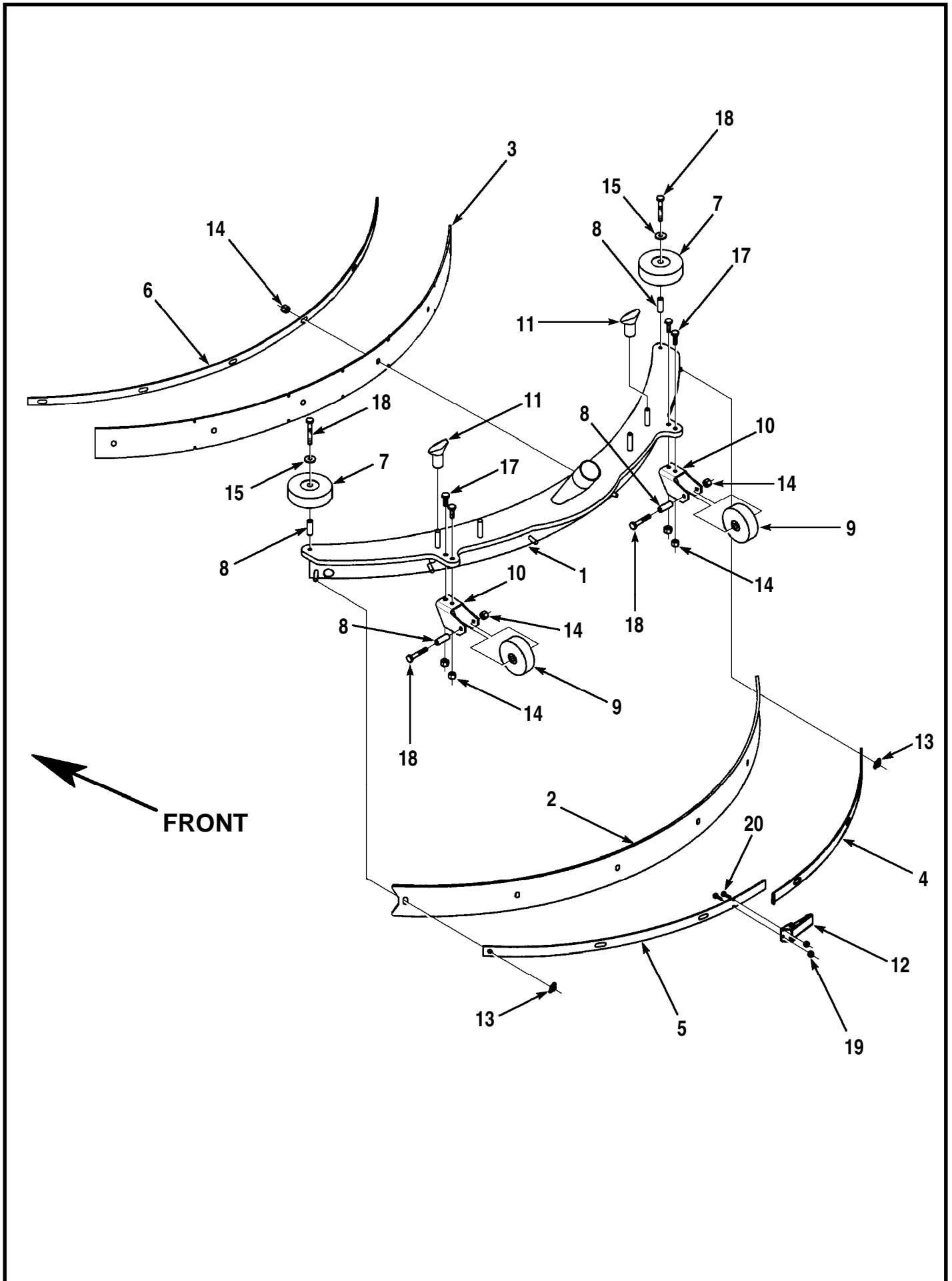

## SQUEEGEE (after SN0603990)

Item	Ref. No.	Qty	Description
	56391281	1	Squeegee Assy (#1-20)
1	56391292	1	Squeegee Tool
2	56391333	1	Main Wiping Blade, Gum Rubber
	56391343	1	Main Wiping Blade, Neoprene
3	56391334	1	Front Blade, Gum Rubber
	56391355	1	Front Blade, Neoprene
4	56391286	1	Right Rear Strap
5	56391288	1	Left Rear Strap
6	56391290	1	Front Strap
7	56324499	2	Wheel
8	56471220	4	Bushing
9	56324350	2	Wheel <b>NOTE</b>
10	56409656	2	Wheel Bracket <b>NOTE</b>
11	56370711	2	Thumb Nut
12	56471194	1	Latch
13	56009048	2	Nut, Wing Loc 1/4-20
14	56002850	12	1/4-20 SS Nyl Loc Nut
15	56002859	2	1/4 Flat Washer
16			<b>Intentionally Omitted</b>
17	56002807	4	1/4-20 x 3/4 SS Screw
18	56002901	4	1/4-20 x 1-1/2 SS Screw
19	56002964	2	#6-32 SS Nyl Loc Nut
20	56002909	2	#6-32 x 3/8 SS Screw
	56391340	1	Standard Blade Kit ( <b>Gum Rubber / #2-3</b> )
	56391342	1	Oil Resistant Blade Kit ( <b>Neoprene / #2-3</b> )

\* = Not Shown

**NOTE:** If replacing original Squeegee Mount Assembly PN 56392665 with the new Mount Assembly PN 56392218, remove the squeegee rollers from the squeegee. The new Squeegee Mount Assembly PN 56392218 has built in rollers.

# WIRING DIAGRAM (before SN 1018020)

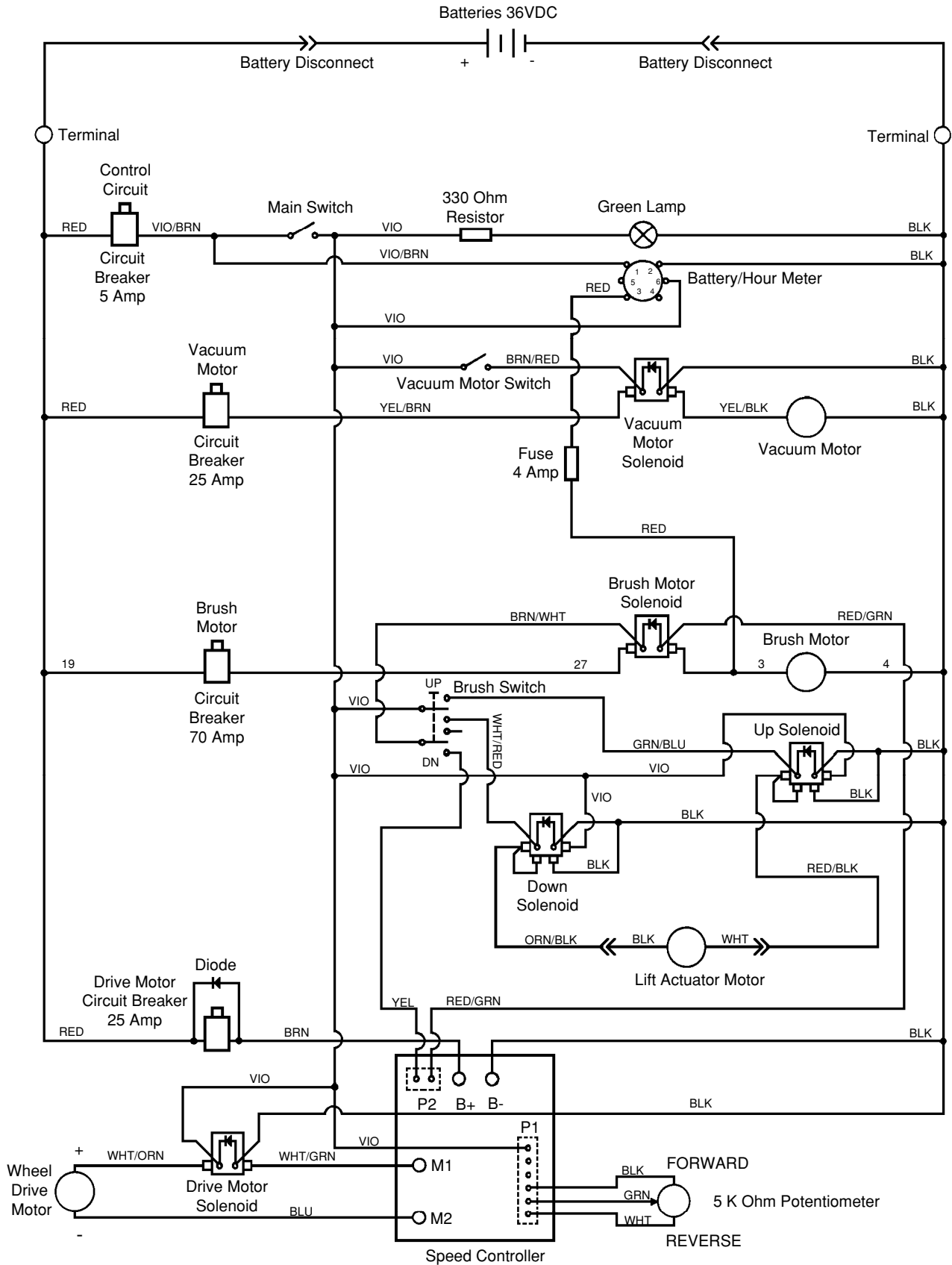

## WIRING DIAGRAM (before SN 1018020)

Ref. No.	Qty	Description
** 56376014	6	Battery 244 Amp Hour
** 56391391	6	Battery 305 Amp Hour
** 56372974	1	Automatic Battery Charger
56391627	1	Actuator
56392668	1	Battery/Hour Meter
56388534	1	Brush Down Solenoid
56389265	1	Diode
56391314	1	Brush Motor
56395452	1	Brush Motor Solenoid <b>TSB 622, G-9 / TSB635, G-2</b>
56389265	1	Diode
56377003	1	Brush Switch
56388534	1	Brush Up Solenoid
56389265	1	Diode
56387328	1	Circuit Breaker 5 Amp, Control Circuit
56469788	1	Circuit Breaker 25 Amp, Drive Motor
56469788	1	Circuit Breaker 25 Amp, Vacuum Motor
56454429	1	Circuit Breaker 70 Amp, Brush Motor
56454813	1	Diode
56388585	1	Drive Motor
56395452	1	Drive Motor Solenoid Note #1
56454831	1	Diode
56406326	1	Fuse 4 Amp
56467410	1	Indicator Light
56478640	1	Main Switch
56391205	1	Main Wiring Harness
56454740	1	Potentiometer
56395404	1	Resistor 330 Ohm
56391210	1	Speed Controller <b>TSB635, G-2</b>
56391208	1	Vacuum Motor
56395452	1	Vacuum Motor Solenoid
56389265	1	Diode
56388019	1	Vacuum Motor Switch

\*\* = Not Included

**Note #1:** This solenoid is only on machines built after February 1993.

# WIRING DIAGRAM (after SN 1018019)

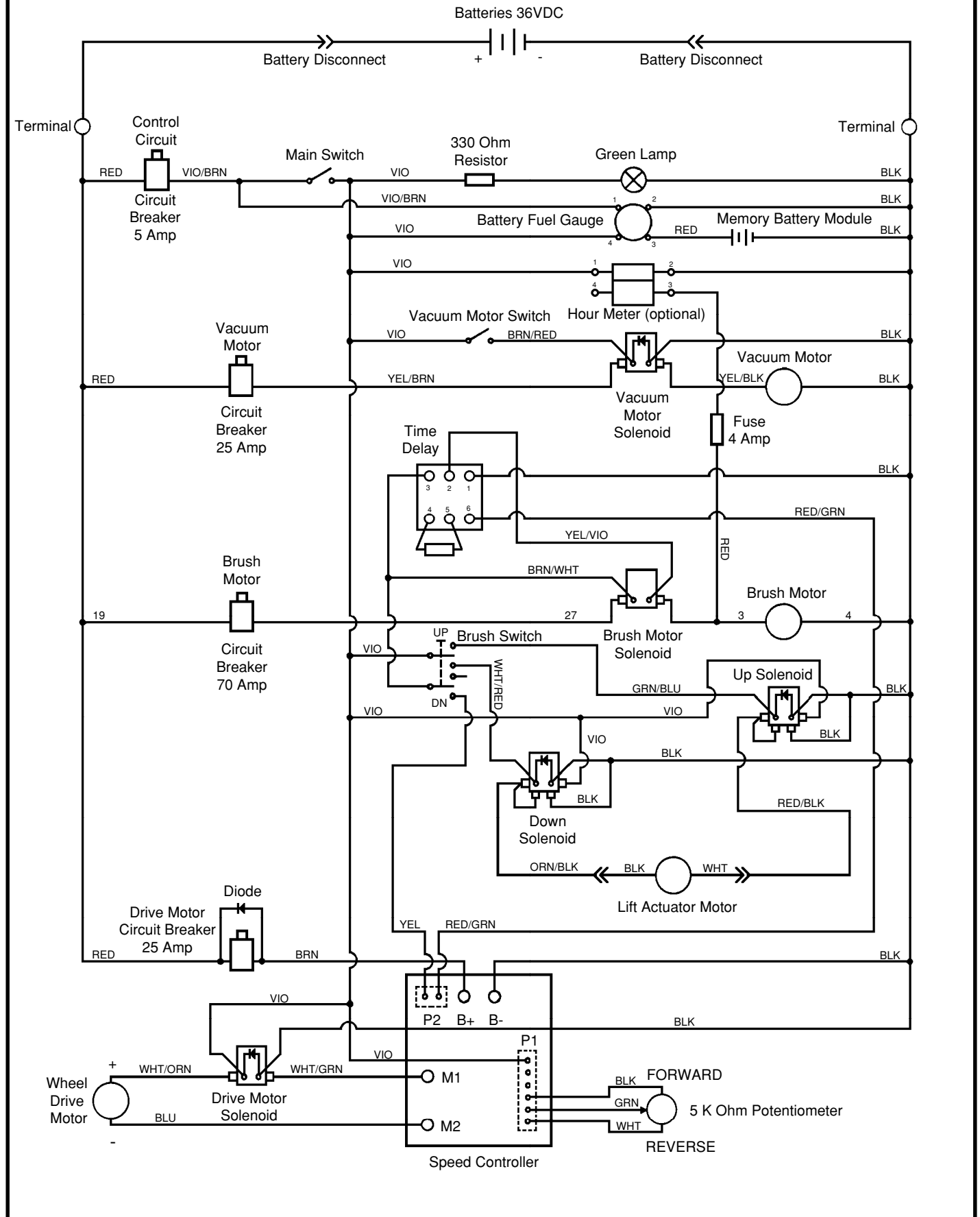

## WIRING DIAGRAM (after SN 1018019)

Ref. No.	Qty	Description
** 56376014	6	Battery 244 Amp Hour
** 56391391	6	Battery 305 Amp Hour
** 56372974	1	Automatic Battery Charger
56391627	1	Actuator
56393717	1	Battery Fuel Gauge
56388534	1	Brush Down Solenoid
56389265	1	Diode
56391314	1	Brush Motor
56395452	1	Brush Motor Solenoid <b>TSB635, G-2/TSB632, F-14</b>
56377003	1	Brush Switch
56388534	1	Brush Up Solenoid
56389265	1	Diode
56387328	1	Circuit Breaker 5 Amp, Control Circuit
56469788	1	Circuit Breaker 25 Amp, Drive Motor
56469788	1	Circuit Breaker 25 Amp, Vacuum Motor
56454429	1	Circuit Breaker 70 Amp, Brush Motor
56454813	1	Diode
56388585	1	Drive Motor
56395452	1	Drive Motor Solenoid
56454831	1	Diode
56406326	1	Fuse 4 Amp
56393718	1	Hour Meter ( <b>optional / order kit PN 56392806</b> )
56467410	1	Indicator Light
56478640	1	Main Switch
56392119	1	Main Wiring Harness
56454740	1	Potentiometer
56395404	1	Resistor 330 Ohm
56391210	1	Speed Controller <b>TSB635, G-2</b>
56391357	1	Time Delay <b>TSB632, F-14</b>
56391208	1	Vacuum Motor
56395452	1	Vacuum Motor Solenoid
56389265	1	Diode
56388019	1	Vacuum Motor Switch

\*\* = Not Included



Nilfisk-Advance, Inc.  
14600 21st Avenue North  
Plymouth, MN, 55447-3408  
[www.nilfisk-advance.com](http://www.nilfisk-advance.com)  
Phone: 800-989-2235  
Fax: 800-989-6566  
©2000 Nilfisk-Advance, Inc.,  
Plymouth, MN 55447-3408  
Printed in the U.S.A.