



Electronic Service Manuals

This electronic document is provided as a service to our customers. We do not create the contents of the information contained in this document. Should you have detailed questions pertaining to the information contained in this document, you may contact Michco, or the manufacturer which provided the original information in this electronic deliverable. Michco's only part in this electronic deliverable was the electronic assembly process.

You may contact Michco through the following methods:
Phone (517) 484-9312 or (800) 331-3339 MI, OH, IN only
2011 N. High St. -- Lansing, Michigan -- 48906
Fax: (517) 484-9836
Email: CustServ@Michco.com
Web site: www.Michco.Com
Parts Web site: www.FloorMachineParts.Com

Order Parts on Line at:
www.FloorMachineParts.Com

Directly to Parts & Service:
By Email: **Shop@Michco.com**
By Fax: (517) 702-2041
By Voice: Use numbers above.

Serving the Cleaning Industry Since 1922

Notice: All copyrighted material remains property of original owners, all trademarks are property of respective owners. Manuals are subject to Manufacturer's reproduction limitations. Originals or reproductions were provided by manufacturers through a request. We make no warranty as to the correctness of information provided in this document and you assume all risk.

Convertamatic™ 200B/LX

Hydro-Retriever™ 200HD

BA 500

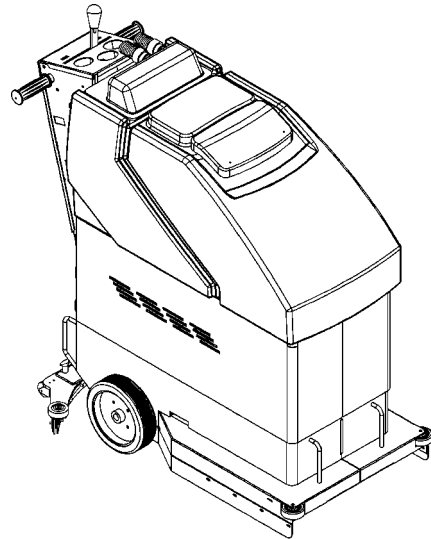
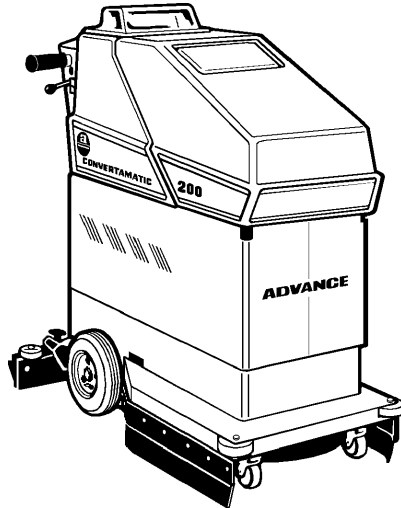

PARTS LIST

**Advance MODELS 56324001(200B), 56324000(200LX)
56324480(200HD)**

Nilfisk MODEL 56324400(BA 500)

**Convertamatic™ 200B/LX after SN 1034008 / Hydro-Retriever™ 200HD after SN
1084202**

All models covered in this manual are OBSOLETE



**Nilfisk
Advance**

setting standards

12/94 revised 9/03 FORM NUMBER 56042291

BOOK E SECTION 3.3.1

DESCRIPTION	PLAN
Handle System	E-3.3.1-3
Battery Case System	E-3.3.1-5
Chassis System-200B / 200LX / BA 500	E-3.3.1-7
Chassis System-200HD	E-3.3.1-9
Vacuum Motor System (before SN 1087006)	E-3.3.1-11
Vacuum Motor System (after SN 1087005, except SN 1087971-SN 1088010)	E-3.3.1-13
Brush Drive System	E-3.3.1-15
Drive System (BA 500 before SN 1068527)	E-3.3.1-17
Drive System (BA 500 after SN 1068526 / all 200)	E-3.3.1-19
Solution System-200B / 200LX / 200HD	E-3.3.1-21
Solution System-BA 500	E-3.3.1-23
Recovery System-200B / 200LX / 200HD	E-3.3.1-25
Recovery System-BA 500	E-3.3.1-27
Squeegee System	E-3.3.1-29
Decal System-200B / 200LX / 200HD	E-3.3.1-31
Decal System-BA 500	E-3.3.1-33
Handle Electrical System-200B	E-3.3.1-35
Handle Electrical System-200LX / 200HD / BA 500	E-3.3.1-37
Chassis Electrical System	E-3.3.1-39
Wiring Diagram-200B	E-3.3.1-41
Wiring Diagram-200LX / 200HD / BA 500	E-3.3.1-43
Brush / Disc Selector Guide	E-3.3.1-44

WHEN ORDERING PARTS

- * Use the 8 digit numbers from the "Ref. No." columns in this parts list.
- * Specify the model and serial number of the machine.
- * Use the space below to record the model and serial number for future reference.

Model _____ Serial No. _____

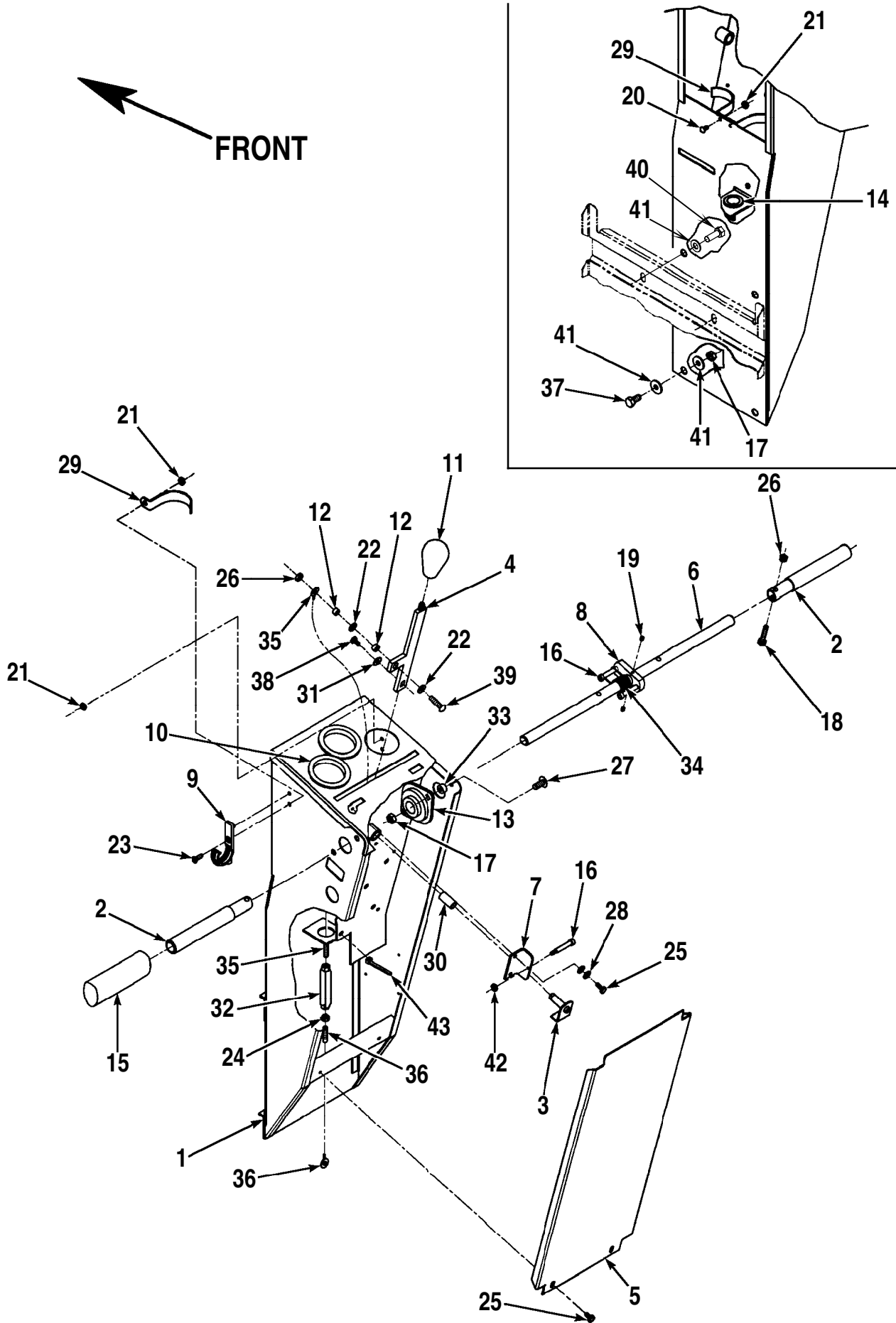

94-12	HANDLE SYSTEM	BOOK E		
01-5	Convertamatic™ 200B/LX / Hydro-Retriever™ 200HD / BA 500	E	3.3.1	3

Item	Ref. No.	Qty	Description
1	56324111	1	Control Handle
2	56324120	2	Handle Tube
3	56324361	1	Actuator
4	56324129	1	Handle
5	56324130	1	Cover
6	56324131	1	Handle Bar
7	56324132	1	Stop Bracket
8	56324133	1	Handle Spring Lever
9	56324349	2	Hook
10	56324195	2	Grommet
11	56364527	1	Knob
12	56206784	2	Bushing
13	56393264	2	Bearing
14	56491648	1	Bearing
15	56388545	2	Handle Grip
16	56003214	3	#10-24 SHD Screw
17	56002701	8	5/16-18 Nyl Loc Nut
18	56002093	2	1/4-20 x 1 Screw
19	56009084	2	#10-24 x 3/16 Set Screw
20	56002503	2	#10-24 x 1/2 Screw
21	56002768	6	#10-24 Nyl Loc Nut
22	56009025	2	Washer
23	56002099	2	#10-24 x 5/8 Screw
24	56009087	1	1/4-20 Jam Nut
25	56009012	4	#10-24 x 3/8 HP-5 Screw
26	56002840	3	1/4-20 Nyl Loc Nut
27	56002794	4	5/16-18 x 1 Bolt
28	56001954	2	Washer
29	56180030	3	Clamp
30	56200972	1	Bearing
31	56009096	1	Washer
32	56206814	1	1/4 x 2-7/8 Turn Buckle
33	56320595	4	Bushing
34	56324033	1	Torsion Spring
35	56324036	1	Upper Wire Rope
36	56324326	1	Lower Wire Rope
37	56002221	2	Scr, Hex Hd 5/16-18 x 1.00
38	56002926	1	#10-24 x 3/8 Loc Screw
39	56002292	1	1/4-20 x 1 Screw
40	56002929	2	Scr, Hex Hd 5/16-18 x .62
41	56001939	6	5/16 Flat Washer
42	56002832	1	#10-24 Thin Nyl Loc Nut
43	56900753	2	Push Tie

* = Not Shown

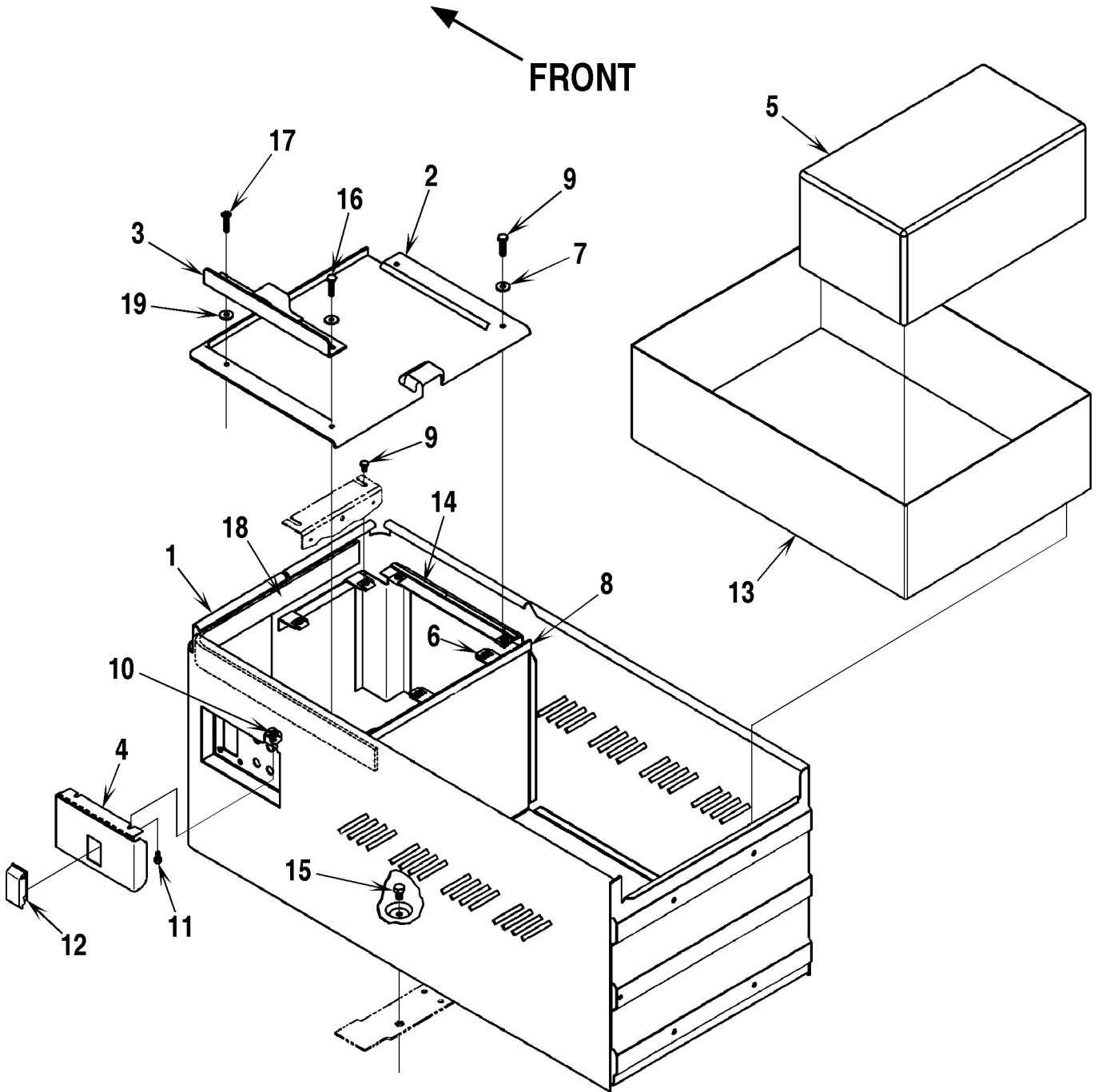

94-12	BATTERY CASE SYSTEM	BOOK E		
01-5	Convertamatic™ 200B/LX / Hydro-Retriever™ 200HD / BA 500	E	3.3.1	5

Item	Ref. No.	Qty	Description
1	56324064	1	Battery Case Weld't
2	56324071	1	Cover
3	56324072	1	Support Bracket Weld't
4	56324393	1	Cover Weld't
5	56324357	1	Spacer, Batteries (200B only)
6	56321520	8	Nut, Clamp 1/4-20
7	56900737	3	Washer, Sealing
8	56755581	15"	Trim, Raw (38.55cm)
9	56002729	6	Scr, Hex Hd Loc 1/4-20 x .50
10	56002768	2	Nut, Hex Nyl Loc 10-24
11	56002834	2	Scr, Hex Hd 10-24 x .38
12	56393358	1	Latch, Slide
13	56374905	1	Tray, Plastic
14	56209435	1	Gasket
15	56002923	2	Scr, Hex Hd Loc 5/16-18 x .50
16	56002922	1	Scr, Hex Hd Loc 1/4-20 x .62
17	56002921	1	Scr, Flt Phil Loc 1/4-20 x .50
18	56324373	1	Gasket
19	56324374	1	Washer Sealing

Convertamatic™ 200B/LX / BA 500

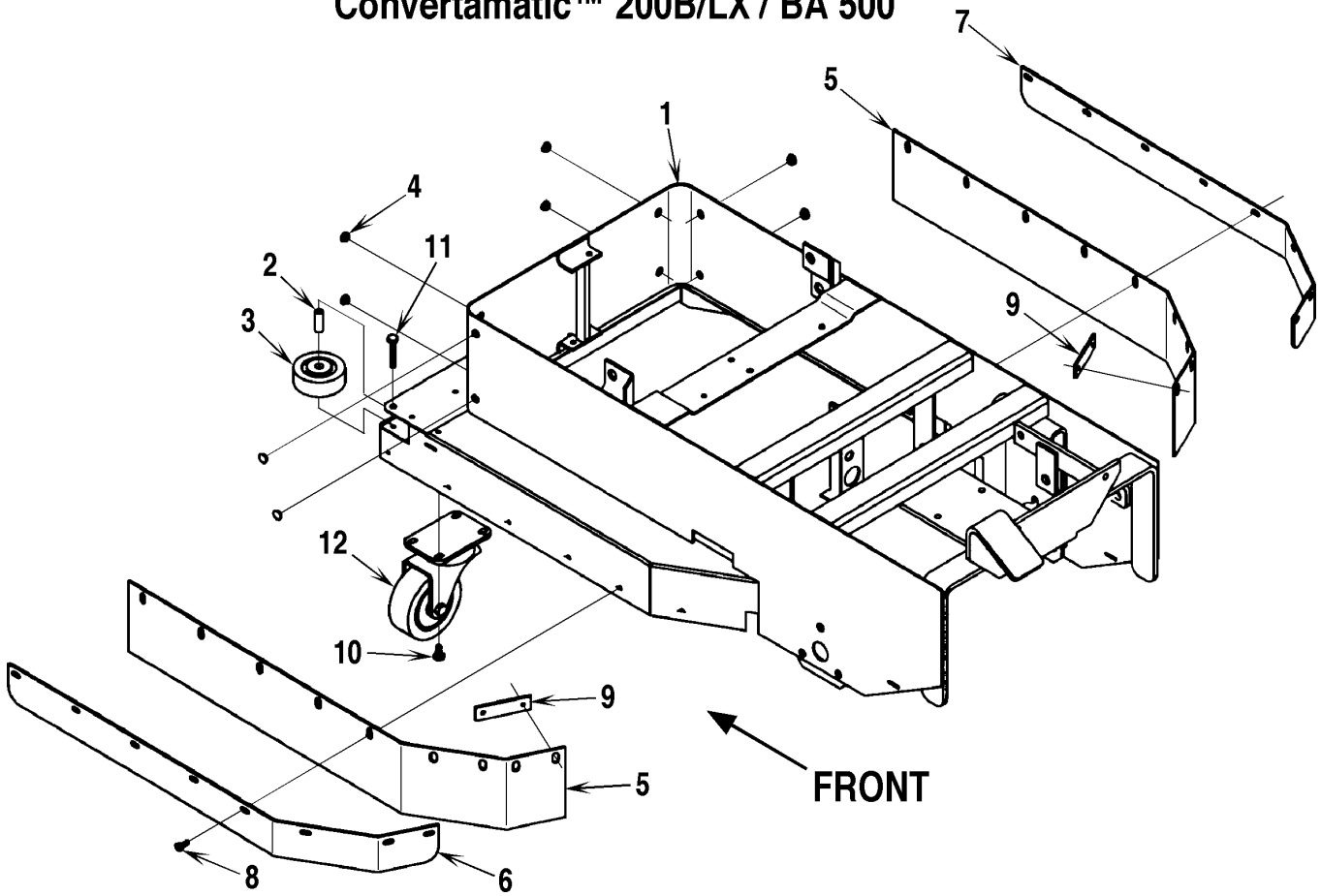

94-12	CHASSIS SYSTEM-200B / 200LX / BA 500	BOOK E		
01-5	Convertamatic™ 200B/LX / Hydro-Retriever™ 200HD / BA 500	E	3.3.1	7

Item	Ref. No.	Qty	Description
1	56324153	1	Chassis Weld't
2	56360139	2	Bushing
3	56324350	2	Wheel
4	56153699	8	Plug Button
5	56382905	2	Guard, Rubber
6	56324286	1	Strap, Left
7	56324287	1	Strap, Right
8	56002520	16	Scr, Hex Thd Form 10-24 x .50
9	56324220	2	Bar
10	56002513	6	Scr, Hex HP5 1/4-20 x .50
11	56002537	2	Scr, HWH HP5 1/4-20 x 1.50
12	56206725	2	Caster

Hydro-Retriever™ 200HD

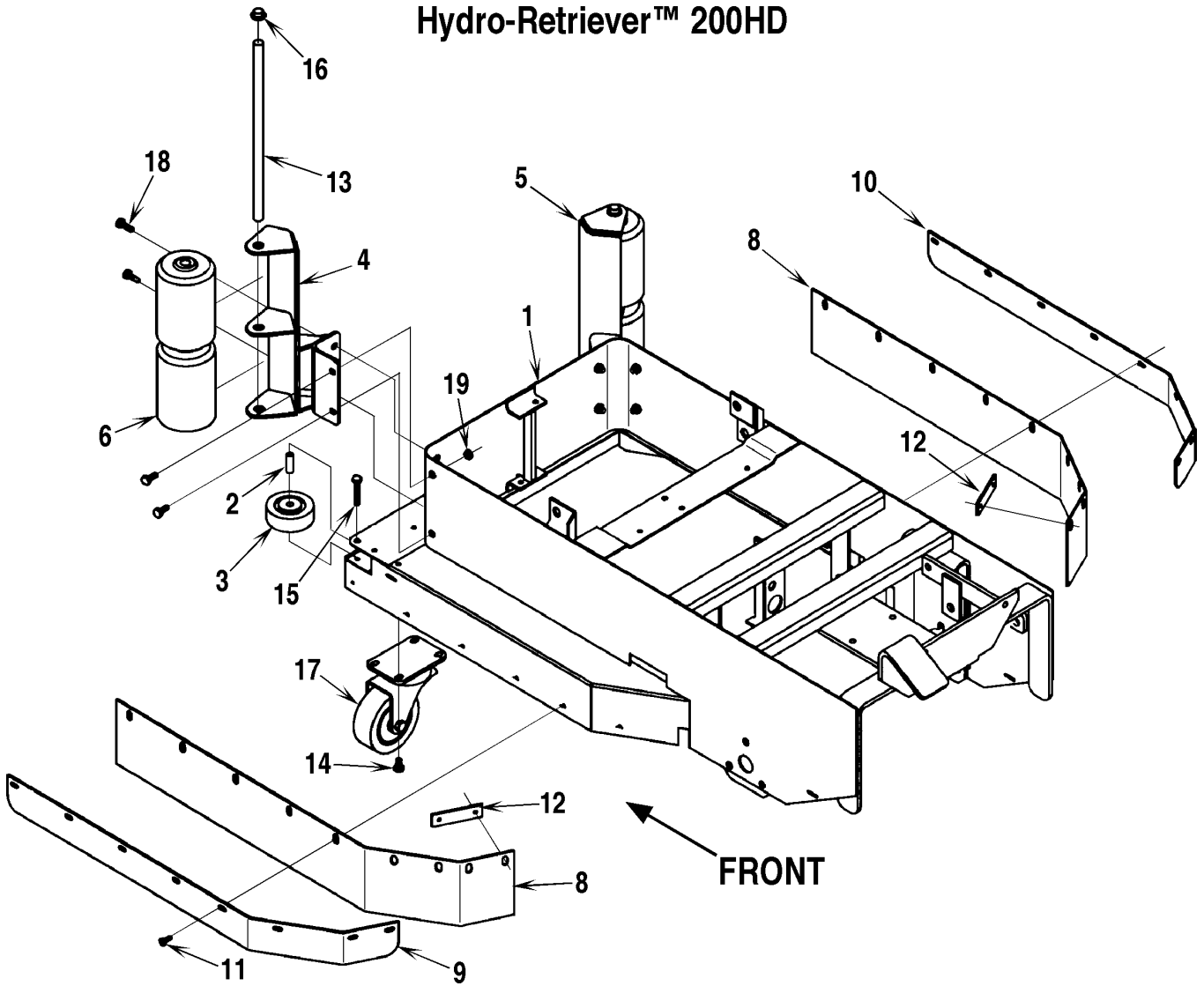

94-12	CHASSIS SYSTEM-200HD	BOOK E		
01-5	Convertamatic™ 200B/LX / Hydro-Retriever™ 200HD / BA 500	E	3.3.1	9

Item	Ref. No.	Qty	Description
1	56324153	1	Chassis Weld't
2	56360139	2	Bushing
3	56324350	2	Wheel
4	56324477	1	Left Bumper Weld't
5	56324479	1	Right Bumper Weld't
6	56392102	4	Roller
7	56371009	2	Washer
8	56382905	2	Guard, Rubber
9	56324286	1	Strap, Left
10	56324287	1	Strap, Right
11	56002520	16	Scr, Hex Thd Form 10-24 x .50
12	56324220	2	Bar
13	56324494	2	Rod
14	56002513	6	Scr, Hex HP5 1/4-20 x .50
15	56002537	2	Scr, HWH HP5 1/4-20 x 1.50
16	56009097	4	Push Cap 1/2
17	56206725	2	Caster
18	56001836	4	Scr, Hex Hd 1/4-20 x .62
19	56002773	4	Nut, Hex Nyl Loc 1/4-20

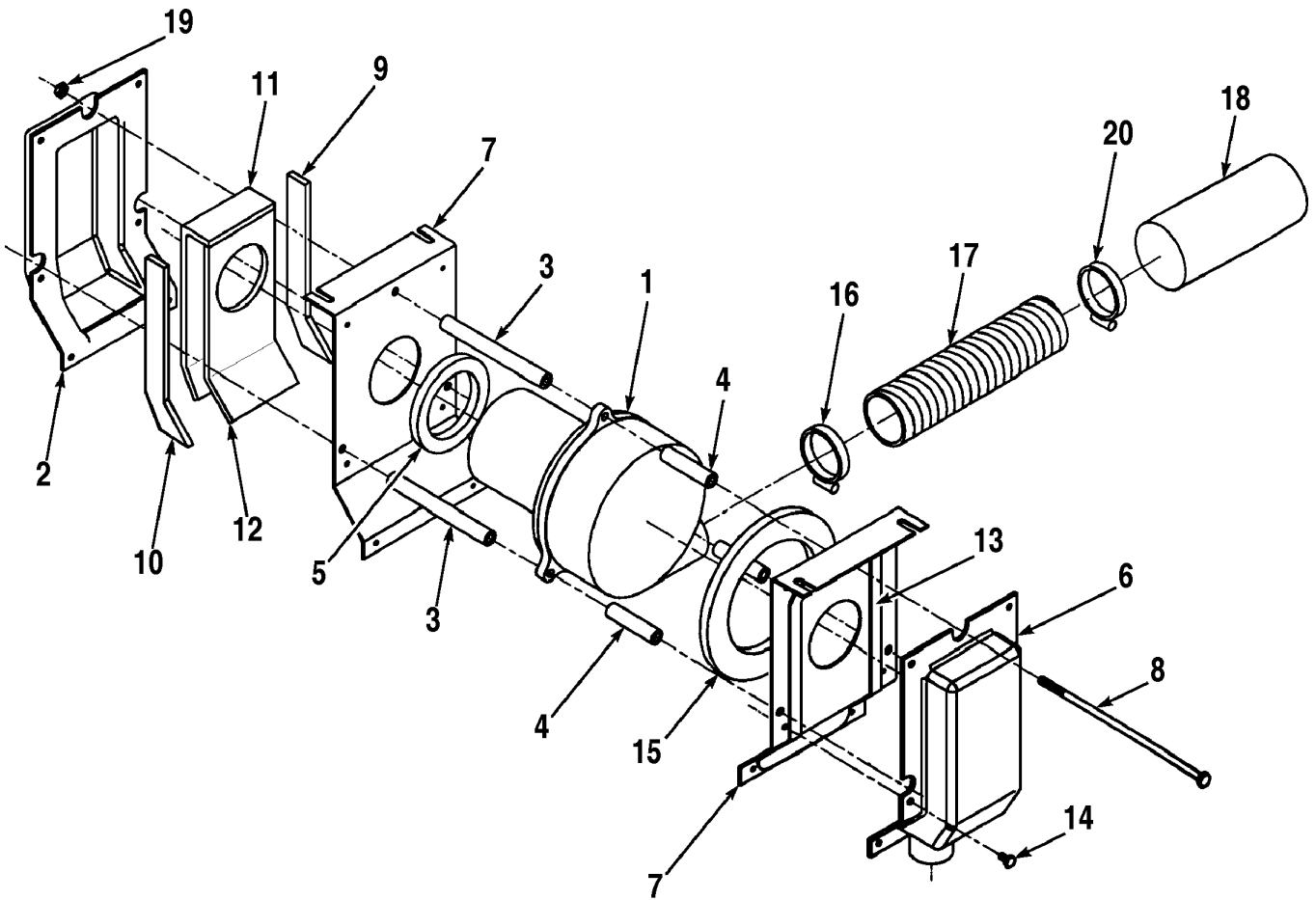

← FRONT

94-12	VACUUM MOTOR SYSTEM (before SN 1087006)	BOOK E		
03-9	Convertamatic™ 200B/LX / Hydro-Retriever™ 200HD / BA 500	E	3.3.1	11

Item	Ref. No.	Qty	Description
1	56324189	1	Vacuum Motor
*	56503003	1	Carbon Brush Set for Vacuum Motor
2	56324092	1	Intake Shroud
3	56324094	3	Spacer
4	56324095	3	Spacer
5	56324040	1	Gasket
6	56324097	1	Shroud
7	56324098	2	Vacuum Motor Bracket
8	56002776	3	1/4-20 x 8 Screw
9	56324099	1	Foam
10	56324100	1	Foam
11	56324101	1	Foam
12	56324102	1	Foam
13	56200754	30"	Gasket (77.1 cm)
14	56002519	12	#10-24 x 3/8 HP-5 Screw
15	56385437	1	Gasket
16	56440213	1	Hose Clamp
17	56324358	1	Hose
18	56324359	1	Foam
19	56002708	3	1/4-20 Nyl Loc Nut
20	56477613	1	Cable Tie

* = Not Shown

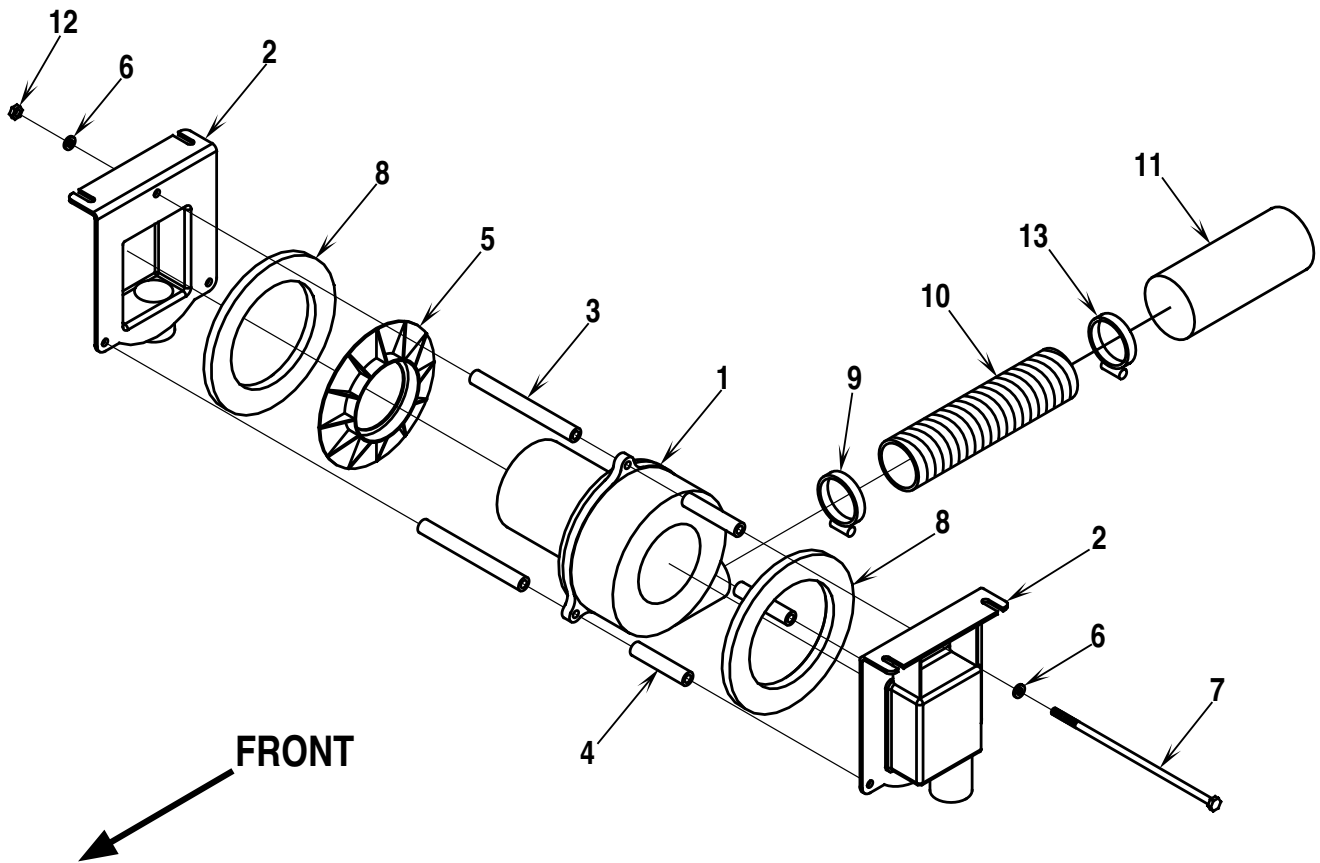

94-12	VACUUM MOTOR SYSTEM (after SN 1087005*)	BOOK E		
03-9	Convertamatic™ 200B/LX / Hydro-Retriever™ 200HD / BA 500	E	3.3.1	13

Item	Ref. No.	Qty	Description
1	56324189	1	Vacuum Motor
*	56503003	1	Carbon Brush Set for Vacuum Motor
2	56324458	2	Shroud
3	56324461	3	Spacer
4	56324462	3	Spacer
5	56324459	1	Flange
6	56002098	6	Wsh, Flt SAE 1/4
7	56002776	3	Scr, Hex Hd 1/4-20 x 8.00
8	56385437	2	Gasket
9	56440213	1	Hose Clamp
10	56324358	1	Hose
11	56324359	1	Foam, Acoustical
12	56002708	3	Nut, Hex Nyl Loc 1/4-20
13	56477613	1	Cable Tie

* = Not Shown

* **NOTE:** Except serial nos. 1087971 through 1088010.

FRONT

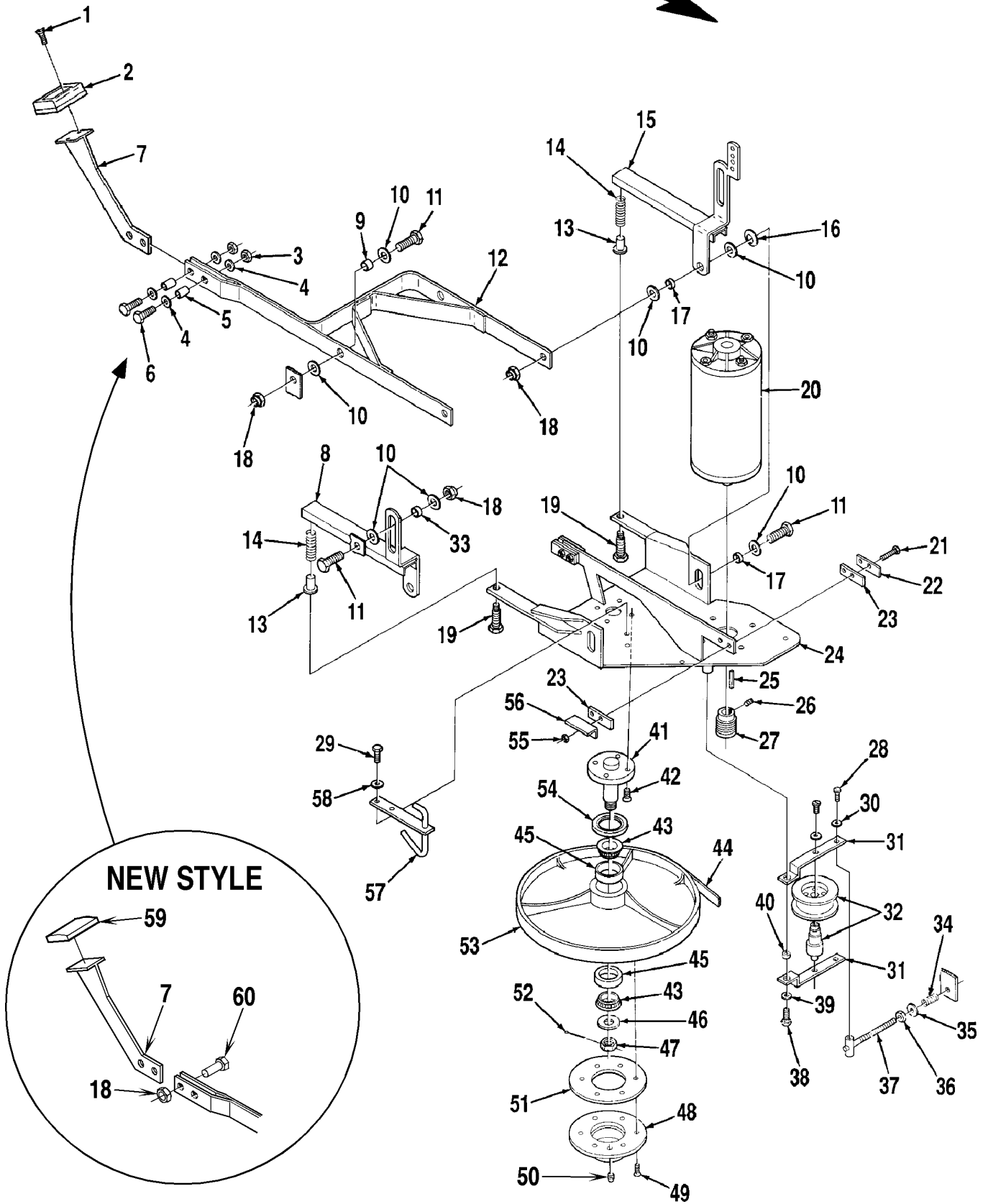

94-12	BRUSH DRIVE SYSTEM	BOOK E		
01-5	Convertamatic™ 200B/LX / Hydro-Retriever™ 200HD / BA 500	E	3.3.1	15

Item	Ref. No.	Qty	Description	Item	Ref. No.	Qty	Description
1	56002711	2	1/4-20 x 7/8 Fit Hd Screw	51	56158275	1	Gasket
2	56365081	1	Plate NOTE	52	56001882	1	1/16 x 1 Cotter Pin
	56365082	1	Rubber Pad NOTE	53	56171376	1	Pulley
	56365083	1	Pedal Cup NOTE	54	56171078	1	Seal
3	56002841	2	3/8-16 Thin Nyl Loc Nut	55	56002708	4	1/4-20 Nyl Loc Nut
4	56002063	4	3/8 Flat Washer	56	56382984	1	Bracket
5	56244859	2	Bushing	57	56385776	1	Solution Pipe
6	56001858	4	3/8-16 x 1-1/4 Bolt	58	56009002	2	Washer
7	56324386	1	Plate NOTE	59	56365002	1	Pad, Rubber NOTE
8	56385890	1	Bracket	60	56001995	2	Scr, Hex Hd 1/2-13 x 1.75
9	56360627	2	Bushing	Brushes For Silver NP-47 Drive Cap			
10	56009017	14	Washer	**	56505455	1	Short-Trim Pad Holder
11	56001831	6	1/2-13 x 1-1/4 Bolt	**	56505048	1	Dyna Grit™ 80 Brush
12	56324380	1	Brush Linkage	**	56505058	1	Magna Grit™ 46 Brush
13	56386216	2	Guide Bushing	**	56505063	1	AgLite™ 500 Brush
14	56373869	2	Spring	**	56505077	1	ProLite™ Brush
15	56385893	1	Bracket	**	56505079	1	MidLite Grit™ 180 Brush
16	56009130	2	Bowed Washer	**	56505083	1	MidGrit™ 240 Brush
17	56382086	4	Bushing	**	56505450	1	Prolene Brush
18	56002843	8	1/2-13 Thin Nyl Loc Nut	**	56505454	1	Union Mix Brush
19	56002470	2	Adjusting Bolt	Brushes For Gold NP-92 Drive Cap			
20	56386261	1	Brush Drive Motor	**	56505920	1	Short-Trim Pad Holder
*	56386263	1	Carbon Brush Set (for #20)	**	56505280	1	Level-Set Pad Holder
21	56001878	4	1/4-20 x 1-1/4 Screw	**	56505922	1	Dyna Grit™ 80 Brush
22	56386160	3	Plate	**	56505921	1	Magna Grit™ 46 Brush
23	56386105	4	Wear Strip	**	56505923	1	AgLite™ 500 Brush
24	56385914	1	Bracket	**	56505925	1	ProLite™ Brush
25	56443719	1	3/16 x 1-3/8 Key	**	56505928	1	MidLite Grit™ 180 Brush
26	56002086	2	5/16-18 x 1/4 Set Screw	**	56505927	1	MidGrit™ 240 Brush
27	56171088	1	Sheave	**	56505924	1	Prolene Brush
28	56002926	4	#10-24 x 3/8 Loc Screw	**	56505926	1	Union Mix Brush
29	56009018	2	1/4-20 x 3/4 HP-5 Screw	**	56393567	A/R	"Big Mouth" Pad Retainer
30	56001954	4	#10 Flat Washer	**	56506001	A/R	Clutch Plate (Silver/NP-47)
31	56386290	2	Bracket	**	56506006	A/R	Clutch Plate (Plastic/NP-92)
32	56171734	1	Idler Assembly				
	56171735	1	Pulley				
	56171733	1	Shaft				
33	56365030	2	Bushing	* = Not Shown			
34	56171271	1	Spring	** = Optional Accessory, Not Included			
35	56001939	1	5/16 Flat Washer				
36	56002701	2	5/16-18 Nyl Loc Nut				
37	56386273	1	Linkage				
38	56002960	1	1/4-20 x 7/8 Loc Screw				
39	56002098	1	1/4 Flat Washer				
40	56368989	1	Bushing				
41	56171056	1	Shaft				
42	56002517	4	1/4-20 x 3/4 HP-5 Screw				
43	56378267	2	Bearing				
44	56171200	1	Belt				
45	56378259	2	Bearing Race				
46	56163449	1	Washer				
47	56158313	1	Nut				
48	56163430	1	Drive Cap (Silver/NP-47)				
	56163431	1	Drive Cap (Gold/NP-92)				
49	56009065	6	#10-24 x 1/2 Flat Hd HP-5 Screw				
50	56361321	1	Catch				

NOTE: All (3) items listed in item #2 are obsolete. They have been replaced by item #59. Item #7 retained its original part number but was revised to accommodate the new rubber pad item #59. If you have a machine with the old style rubber pad item #2 and need to replace the pad, order item #59 and a new item #7. Likewise, if you need to replace just item #7, you will also need to order item #59.

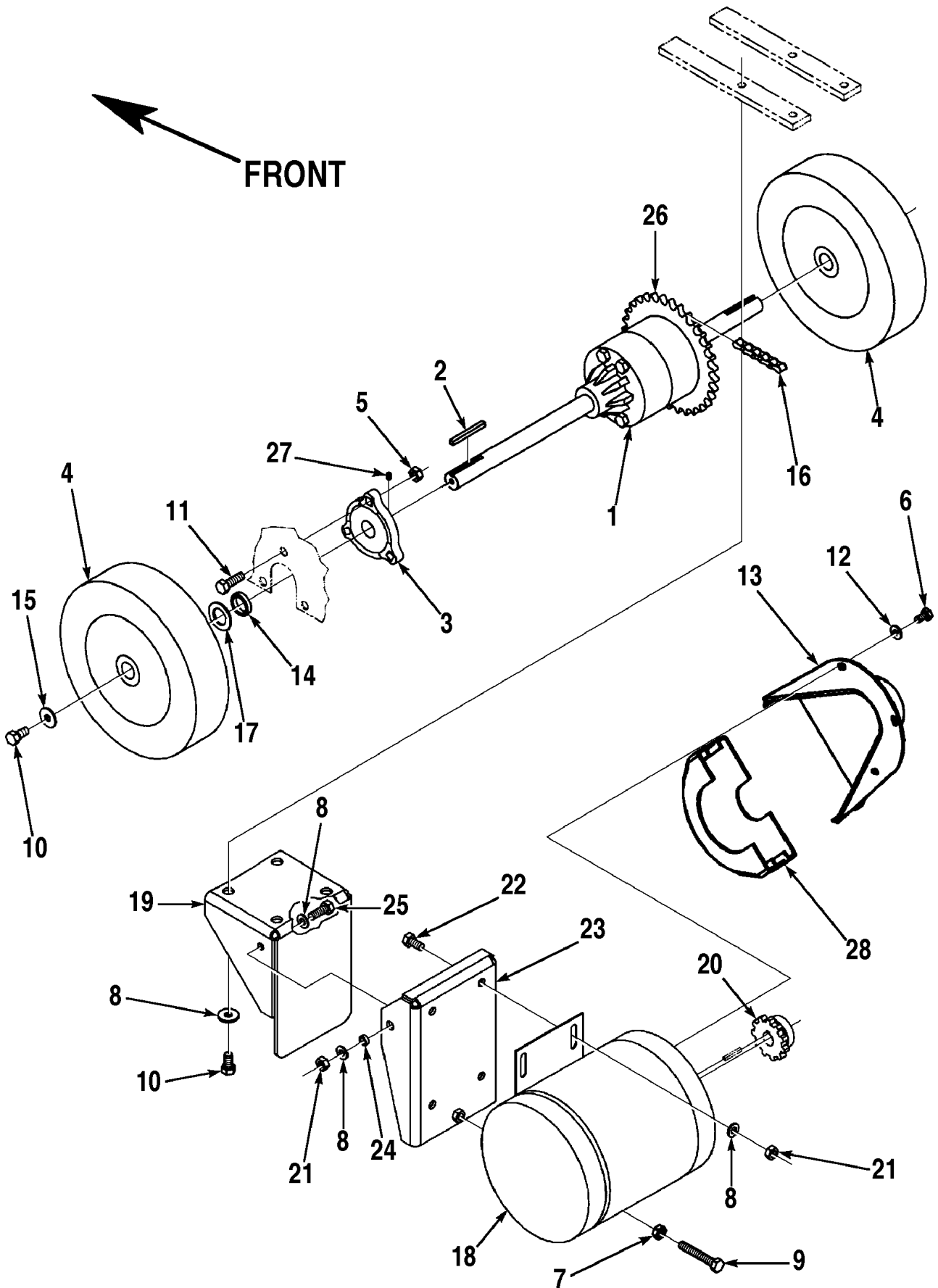

94-12	DRIVE SYSTEM (BA 500 before SN 1068527)	BOOK E		
03-9	Convertamatic™ 200B/LX / Hydro-Retriever™ 200HD / BA 500	E	3.3.1	17

Item	Ref. No.	Qty	Description
1	56324031	1	Differential
	56324185	1	Differential Assy (#1 & 26)
2	56443719	2	3/16 x 1-5/16 Key
3	56393677	2	Bearing
4	56324246	2	Wheel TSB684
5	56002826	6	5/16-18 Thin Nyl Loc Nut
6	56002729	3	1/4-20 x 1/2 Loc Screw
7	56002025	1	5/16-18 Jam Nut
8	56001939	12	5/16 Flat Washer
9	56002368	1	5/16-18 x 1-3/4 Bolt
10	56002929	6	5/16-18 x 5/8 Loc Bolt
11	56002221	6	5/16-18 x 1 Bolt
12	56002098	3	1/4 Flat Washer
13	56324417	1	Upper Chain Guard
14	56324248	2	Bushing
15	56152781	2	5/16 Flat Washer
16	56324027	1	Roller Chain
17	56367192	2	Washer
18	56324011	1	Drive Motor 24VDC
*	56324253	1	Carbon Brush Set for Drive Motor
19	56324104	1	Motor Mount Bracket
20	56388688	1	Sprocket
21	56002701	6	5/16-18 Nyl Loc Nut
22	56002667	4	5/16-18 x 3/4 Bolt
23	56324215	1	Plate
24	56381818	2	Bushing
25	56002037	2	5/16-18 x 7/8 Bolt
26	56324024	1	Sprocket
27	56002086	2	5/16-18 x 1/4 Loc Set Screw
28	56324419	1	Lower Chain Guard

* = Not Shown

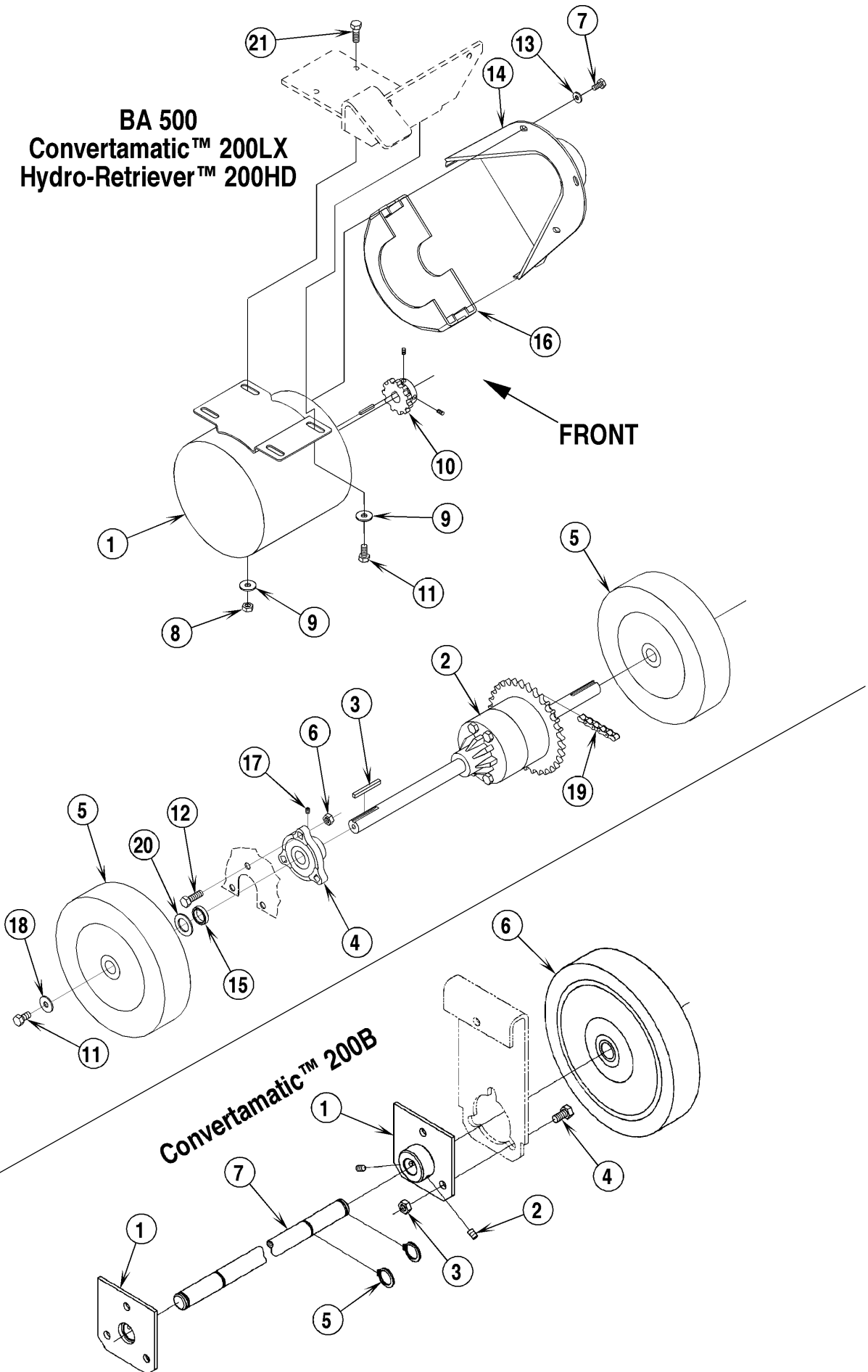

94-12	DRIVE SYSTEM (BA 500 after SN 1068526 / all 200)	BOOK E		
01-5	Convertamatic™ 200B/LX / Hydro-Retriever™ 200HD / BA 500	E	3.3.1	19

Item	Ref. No.	Qty	Description
			Convertamatic™ 200LX / Hydro-Retriever™ 200HD / BA 500
1	56263253	1	Drive Motor
*	56503023	1	Carbon Brush Set for 56263253
2	56324185	1	Differential Assembly (before SN 1185621 / TSB 684)
	56324024	1	Sprocket (for 56324185)
	56324594	1	Differential Assembly (after SN 1185620)
	56324452	1	Sprocket (for 56324594)
3	56443719	2	Key .19 x 1.31 (before SN 1185621 / TSB 684)
	56003246	2	Key, .25 x .1.62 (after SN 1185620)
4	56393677	2	Bearing, Flange (before SN 1185621 / TSB 684)
	56324588	2	Bearing, Flange (after SN 1185620)
5	56324246	2	Wheel, Filled (before SN 1185621 / TSB 684)
	56324584	2	Wheel, Filled (after SN 1185620)
6	56002826	6	Nut, Hex Nyl Loc-Thin 5/16-18
7	56002729	3	Scr, Hex Hd Loc 1/4-20 x .50
8	56002826	2	Nut, Hex Nyl Loc-Thin 5/16-18
9	56001939	4	Washer, SAE 5/16
10	56388688	1	Sprocket
11	56002956	4	Scr, Hex Hd Loc 5/16-18 x .75
12	56002221	6	Scr, Hex 5/16-18 x 1.00
13	56002098	3	Washer, Flt SAE 1/4
14	56324441	1	Guard, Chain
15	56324248	2	Bushing (before SN 1185621 / TSB 684)
	56324590	2	Bushing (after SN 1185620)
16	56324419	1	Guard, Lower Chain
17	56009076	2	Scr, Soc Set Loc 1/4-20 x .31
18	56009094	2	Wsh, Flt SS .375 x 1.25 x .07
19	56324438	1	Chain, Roller
20	56367192	2	Washer, .75 x 1.25 x .12 (before SN 1185621 / TSB 684)
	56748926	2	Washer, 1.03 x 1.50 x .07 (after SN 1185620)
21	56002667	2	Scr, Hex Hd 5/16-18 x .75

* = Not Shown

Item	Ref. No.	Qty	Description
			Convertamatic™ 200B
1	56324230	2	Axle Mount Weld't
2	56002930	4	Scr, Soc Set Loc 1/4-20 x .38
3	56002701	6	Nut, Hex Nyl Loc 5/16-18
4	56002037	6	Scr, Hex Hd 5/16-18 x .88
5	56900884	4	Ret. Ring
6	56377945	2	Wheel, W/Bearing 8.00
7	56324231	1	Shaft, Axle

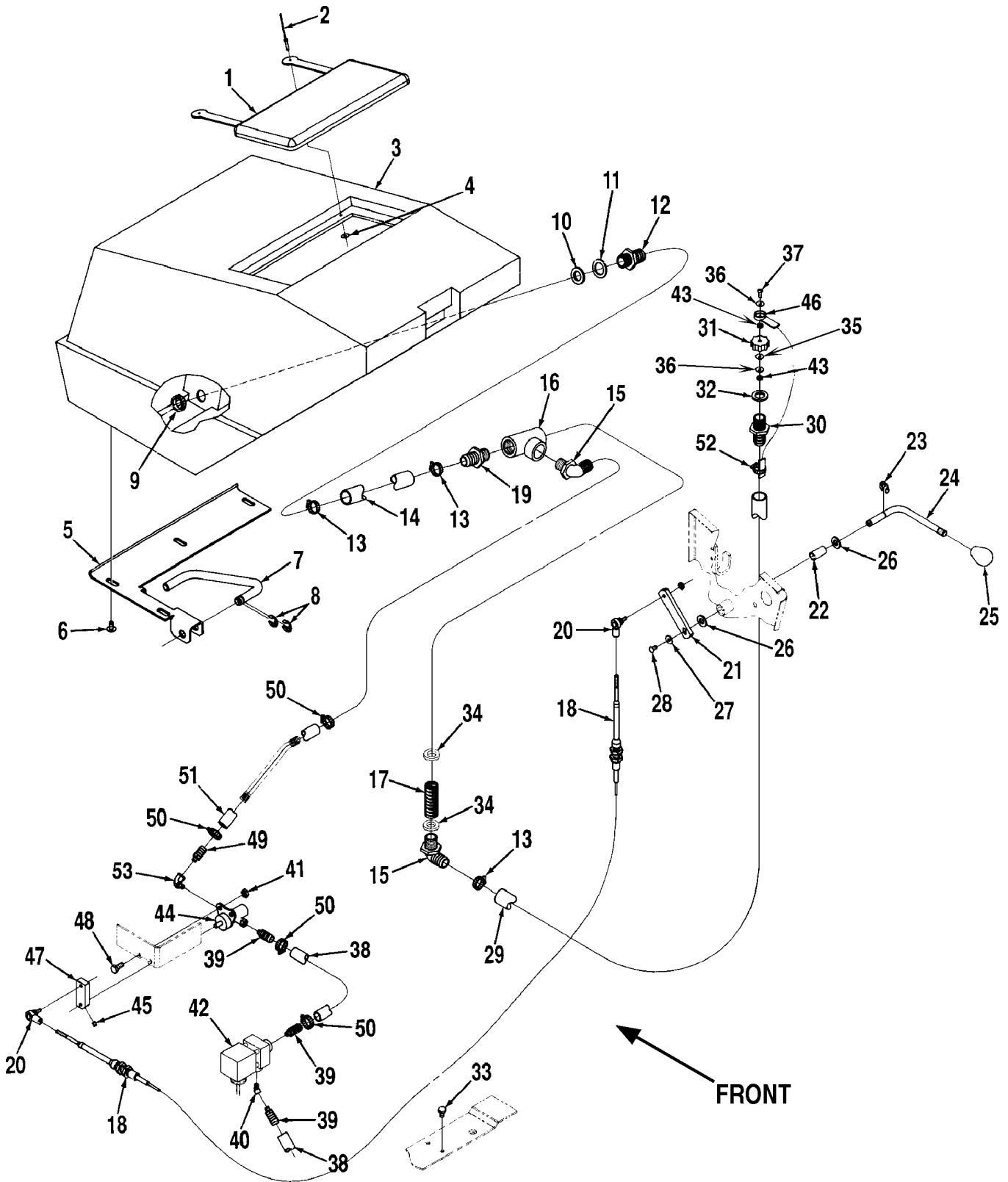

94-12	SOLUTION SYSTEM-200B / 200LX / 200HD	BOOK E		
01-5	Convertamatic™ 200B/LX / Hydro-Retriever™ 200HD / BA 500	E	3.3.1	21

Item	Ref. No.	Qty	Description	Item	Ref. No.	Qty	Description
1	56386062	1	Cover Assembly	29	56324291	1	Hose, Spiral
	56386166	1	Cover	30	56900273	1	Barb
	56263379	2	Strap	31	56324256	1	Cap
2	56900186	4	Pop Rivet	32	56368776	1	Rubber Washer
3	56324211	1	Solution Tank	33	56001861	2	1/4-20 x 3/8 Screw
	56324193	1	Solution Tank Assembly (#1-12)	34	56324313	2	Rubber Washer
4	56263381	2	Washer	35	56209596	1	Washer, Rubber
5	56324077	1	Panel	36	56002916	2	Wsh, Flt SAE SS #10
6	56002924	4	1/4-20 x 1/2 Screw	37	56002895	1	Scr, Pan Phil SS 8-32 x .75
7	56324076	1	Prop Rod	38	56456830	2	Hose
8	56324204	2	Retaining Ring	39	56155640	3	Barb
9	56393187	1	Nut	40	56368938	1	Elbow
10	56249625	1	Restrainer	41	56002708	2	1/4-20 Nyl Loc Nut
11	56154717	1	Rubber Washer	42	56324247	1	Solenoid Valve
12	56393182	1	Barb	*	56324506	1	Viton Seal Kit for 56324247
13	56112771	3	Hose Clamp	*	56324507	1	EPDM Seal Kit for 56324247
14	56324041	1	Hose	43	56002877	2	#8-32 SS Nyl Loc Nut
15	56456802	2	Barb	44	56368903	1	Solution Valve
16	56324029	1	Tee	45	56002015	1	#10-24 x 1/4 Set Screw
17	56324030	1	Filter	46	56324257	1	Strap
18	56324205	1	Cable	47	56324089	1	Handle
19	56900292	1	Barb	48	56001836	2	1/4-20 x 5/8 Screw
20	56488290	2	Ball Joint	49	56373456	1	Barb
21	56324206	1	Link	50	56219932	5	Hose Clamp
22	56200972	1	Bearing	51	56324249	1	Hose
23	56321427	1	Retaining Ring	52	56477613	1	Cable Tie
24	56324216	1	Handle	53	56369632	1	Elbow
25	56378534	1	Knob				
26	56002063	2	3/8 Flat Washer				
27	56203874	1	#10 Flat Washer				
28	56002926	1	#10-24 x 3/8 Screw				

* = Not Shown

94-12	SOLUTION SYSTEM-BA 500	BOOK E		
01-5	Convertamatic™ 200B/LX / Hydro-Retriever™ 200HD / BA 500	E	3.3.1	23

Item	Ref. No.	Qty	Description	Item	Ref. No.	Qty	Description
1	56324389	1	Solution Tank	31	56324216	1	Valve Control Rod
	56324401	1	Solution Tank Assy (#1-12)	32	56002877	2	#8-32 SS Nyl Loc Nut
2	56393182	1	Barb	33	56001836	2	1/4-20 x 5/8 Screw
3	56393187	1	3/4-16 Nut	34	56001861	2	1/4-20 x 3/8 Screw
4	56003293	2	Rivet	35	56477613	1	Cable Tie
5	56002924	4	1/4-20 x 1/2 Loc Screw	36	56002895	1	#8-32 x 3/4 SS Screw
6	56324076	1	Support Rod	37	56112771	3	Hose Clamp
7	56324077	1	Panel	38	56155640	3	Fitting
8	56324411	1	Cover Assembly	39	56219932	4	Hose Clamp
*	56324408	1	Cover	40	56324313	2	Rubber Washer
*	56393777	1	Gasket	41	56324256	1	Cap
*	56263379	2	Strap	42	56324257	1	Strap
*	56263381	2	SS Flat Washer	43	56324029	1	Tee
*	56900186	2	Rivet	44	56324030	1	Filter
9	56324204	2	Retainer Ring	45	56324035	1	Elbow
10	56154717	1	Washer	46	56324041	1	Hose
11	56249625	1	Restrainer	47	56456830	2	Hose
12	56009098	2	SS Flat Washer	48	56002873	1	#10-32 Nyl Loc Nut
13	56002916	2	#10 SS Flat Washer	49	56324291	1	Hose, Spiral
14	56368776	1	Rubber Washer	50	56324241	1	Cable Bracket
15	56324512	1	Valve	51	56324247	1	Solenoid Valve
16	56369632	1	Elbow	*	56324506	1	Viton Seal Kit (for 56324247)
17	56373456	1	Fitting	*	56324507	1	EPDM Seal Kit (for 56324247)
18	56368938	1	Elbow	52	56002708	2	1/4-20 Nyl Loc Nut
19	56456802	1	Elbow	53	56324249	1	Hose
20	56900292	1	Barb	54	56209596	1	Rubber Washer
21	56900273	1	Barb				
22	56324205	1	Control Cable				
23	56324206	1	Linkage Bar				
24	56002926	1	#10-24 x 3/8 Loc Screw				
25	56009096	1	#10 Flat Washer				
26	56003262	1	Retainer Ring				
27	56002063	2	3/8 Flat Washer				
28	56488290	2	Ball Joint				
29	56378534	1	Knob				
30	56200972	1	Bearing				

* = Not Shown

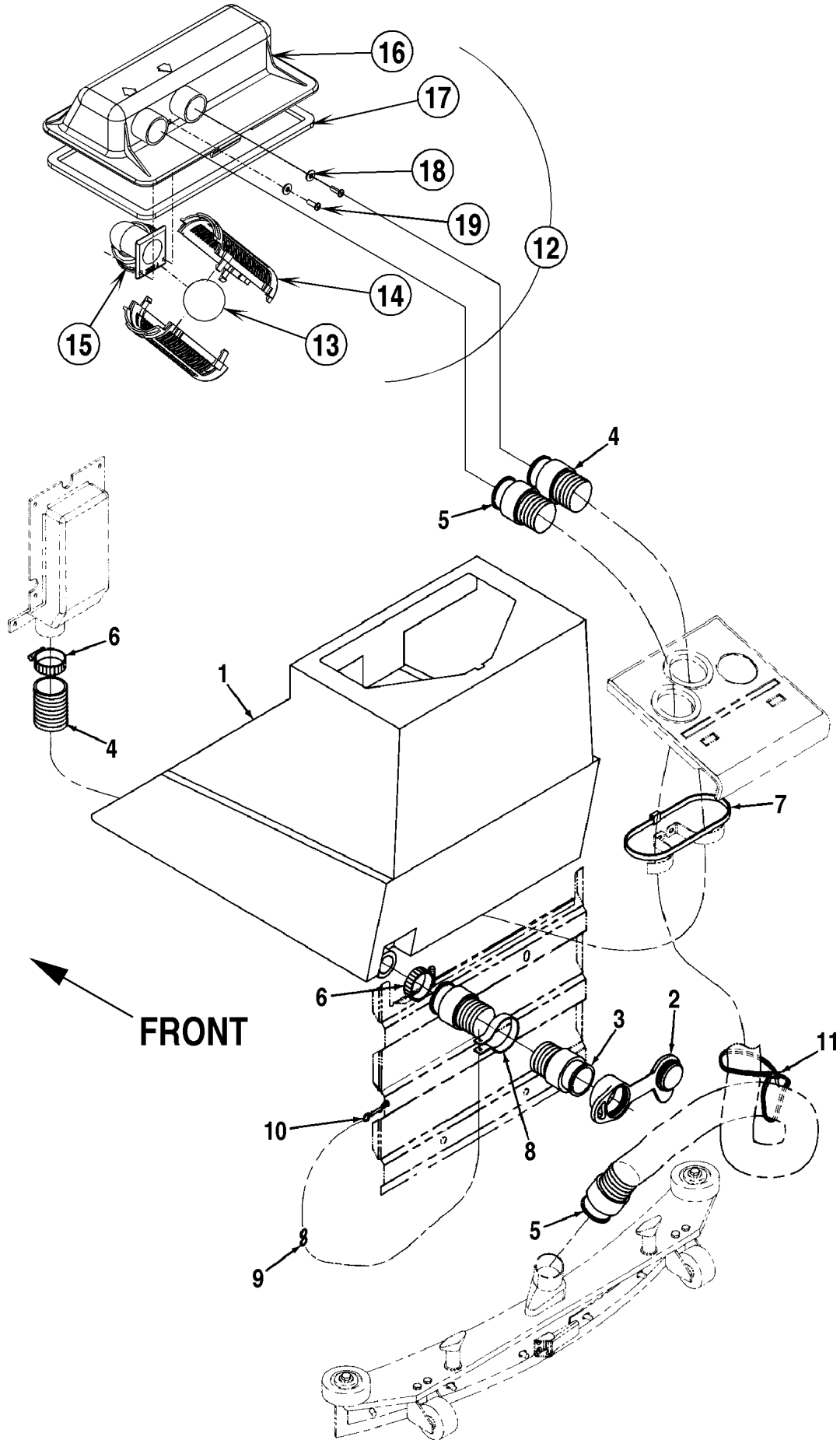

94-12	RECOVERY SYSTEM-200B / 200LX / 200HD	BOOK E		
01-5	Convertamatic™ 200B/LX / Hydro-Retriever™ 200HD / BA 500	E	3.3.1	25

Item	Ref. No.	Qty	Description
1	56324179	1	Tank, Recovery
2	56324180	1	Plug, Drain
3	56372216	1	Hose
4	56391753	1	Hose
5	56324255	1	Hose W/Cuffs
6	56329145	2	Clamp, Hose
7	56477613	5	Cable Tie
8	56263379	1	Strap, Cover
9	56745391	1	"S" Hook
10	56324281	1	Snap, Swivel
11	56393381	1	Tie, Wire
12	56324045	1	Cover Assembly (#13-19)
13	56391690	1	Ball
14	56324497	2	Cage, Float
15	56324298	1	Elbow, Float
16	56324046	1	Cover, Tank
17	56262576	1	Gasket
18	56209261	2	Washer, Sealing 9/16
19	56003633	2	Scr, Pan Phil SS Type B 10-16 x .50

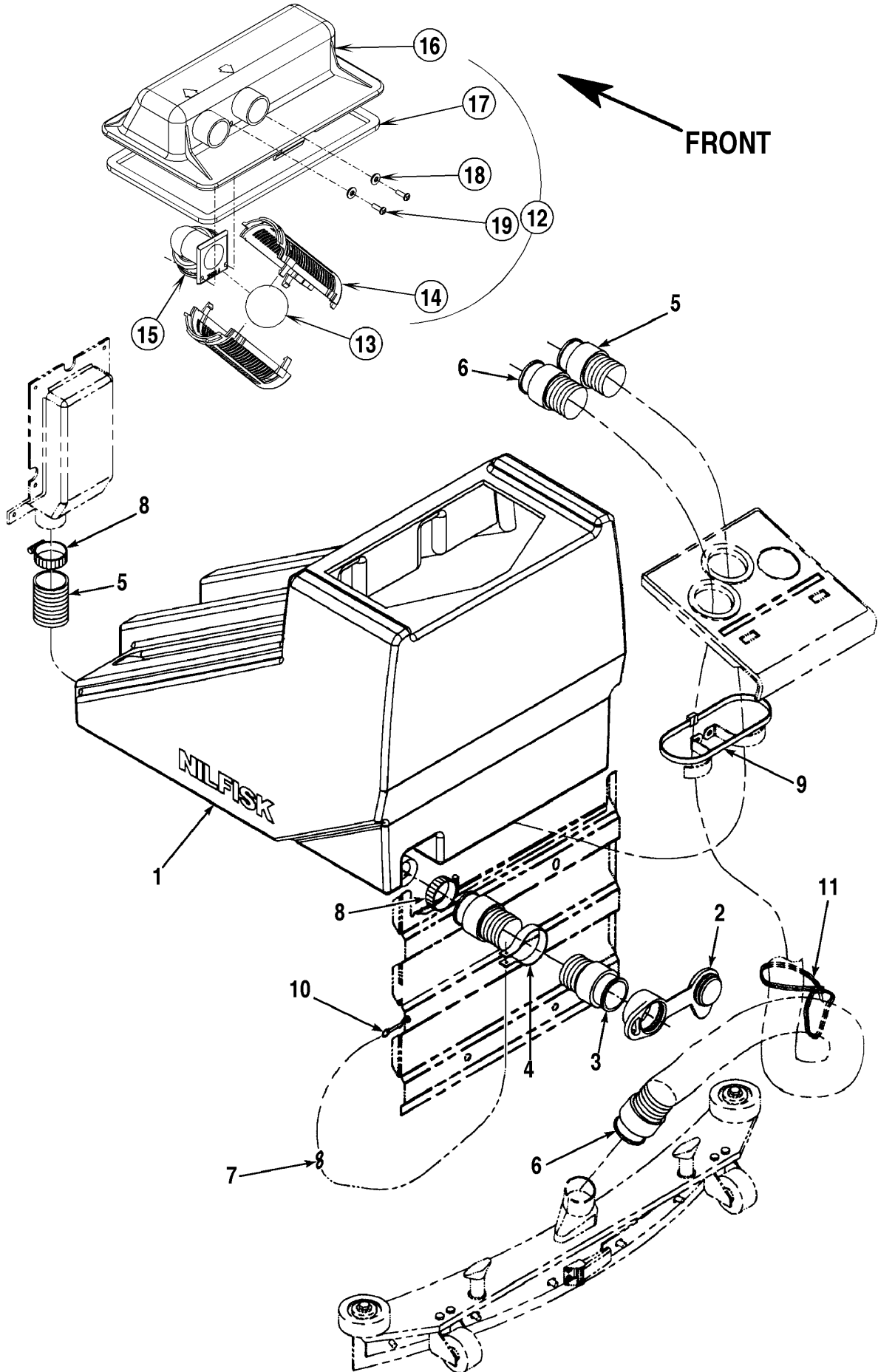

94-12	RECOVERY SYSTEM-BA 500	BOOK E		
01-5	Convertamatic™ 200B/LX / Hydro-Retriever™ 200HD / BA 500	E	3.3.1	27

Item	Ref. No.	Qty	Description
1	56324391	1	Recovery Tank
2	56393772	1	Drain Plug
3	56393770	1	Drain Hose
4	56263379	1	Strap
5	56324775	1	Vacuum Hose
6	56393771	1	Squeegee Hose
7	56745391	1	"S" Hook
8	56329145	2	Hose Clamp
9	56477613	5	Cable Tie
10	56324281	1	Swivel Snap
11	56393381	1	Wire Tie
12	56324396	1	Cover Assembly (#13-19)
13	56391690	1	Ball
14	56324497	2	Cage, Float
15	56324298	1	Elbow, Float
16	56324395	1	Cover, Tank
17	56262576	1	Gasket
18	56209261	2	Washer, Sealing 9/16
19	56003633	2	Scr, Pan Phil SS Type B 10-16 x .50

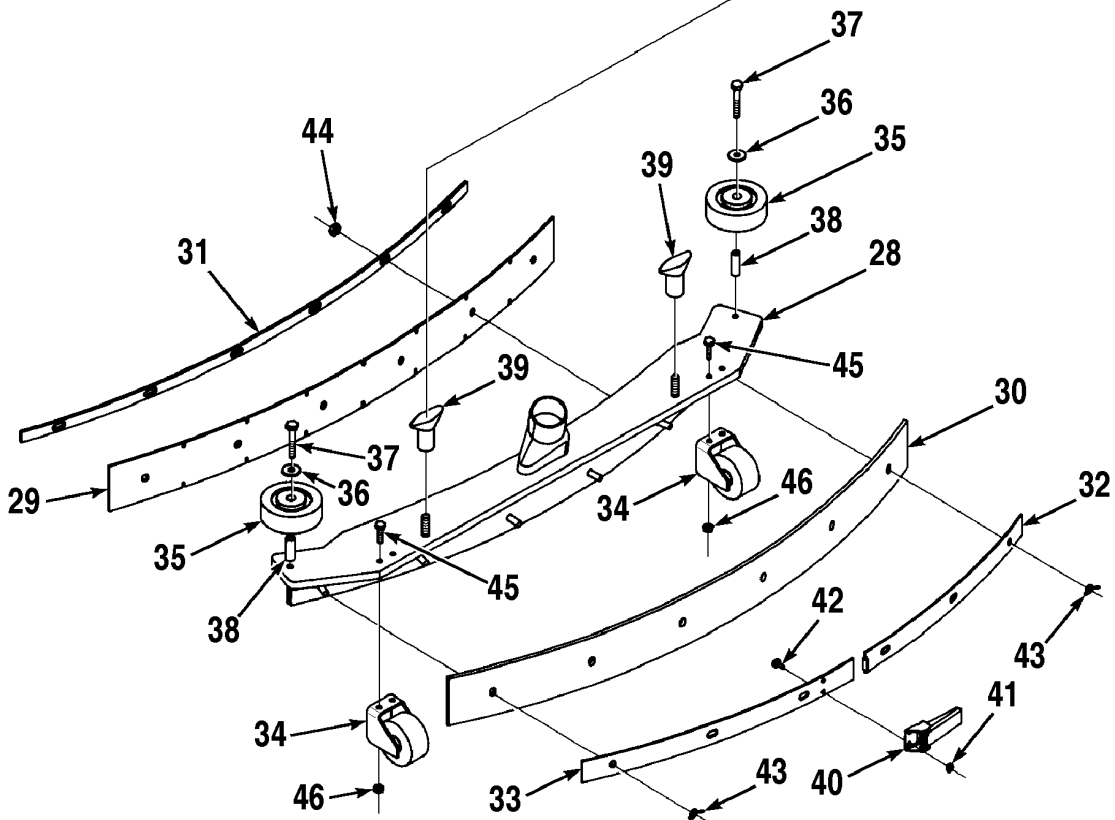
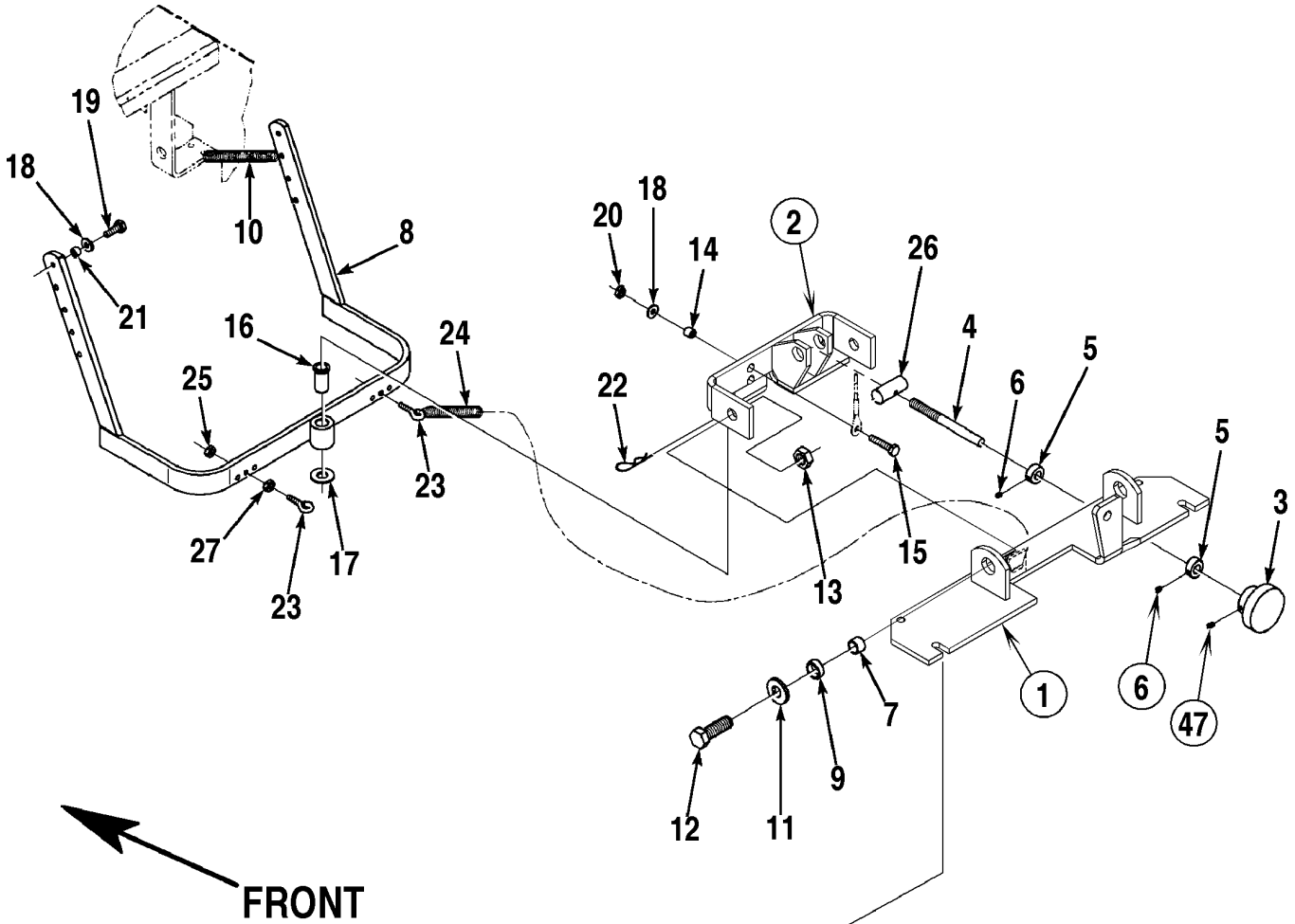

94-12	SQUEEGEE SYSTEM	BOOK E		
02-9	Convertamatic™ 200B/LX / Hydro-Retriever™ 200HD / BA 500	E	3.3.1	29

Item	Ref. No.	Qty	Description
1	56324405	1	Mount
2	56324404	1	Mount
3	56475480	1	Knob
4	56391855	1	Rod
5	56331076	2	Collar
6	56009084	2	#10-24 x 3/16 Loc Set Screw
7	56360627	2	Bushing
8	56324432	1	Linkage
9	56478781	2	Bearing
10	56448112	2	Spring
11	56001879	2	1/2 Flat Washer
12	56001968	2	1/2-13 x 1-1/2 Bolt
13	56002770	2	1/2-13 Nyl Loc Nut
14	56324321	1	Bushing
15	56001821	1	1/4-20 x 7/8 Screw
16	56492471	1	Bearing
17	56001953	1	7/16 Flat Washer
18	56002098	3	1/4 Flat Washer
19	56009018	2	1/4-20 x 3/4 HP-5 Screw
20	56002708	1	1/4-20 Nyl Loc Nut
21	56206784	2	Bushing
22	56002959	1	Pin
23	56009202	2	Eye Bolt
24	56470672	2	Spring
25	56002832	2	#10-24 Thin Nyl Loc Nut
26	56324369	1	Pin
27	56009009	2	#10-24 Nut
28	56324403	1	Squeegee Tool
	56324397	1	Squeegee Tool Assy (#28-46)
29	56324325	1	Front Blade (std. & oil res.)
30	56324322	1	Rear Blade (std.)
	56324383	1	Rear Blade (oil res.)
31	56324402	1	Front Strap
32	56324398	1	Right Rear Strap
33	56324399	1	Left Rear Strap
34	56393755	2	Roller
35	56363855	2	Wheel
36	56002859	2	1/4 SS Flat Washer
37	56002993	2	1/4-20 x 1-1/2 SS Screw
38	56471220	2	Bushing
39	56370711	2	Thumb Nut
40	56471194	1	Latch
41	56002964	2	#6-32 SS Thin Nyl Loc Nut
42	56002909	2	#6-32 x 3/8 SS Pan Hd Screw
43	56002963	2	1/4-20 SS Wing Nut
44	56002850	6	1/4-20 SS Thin Nyl Loc Nut
45	56002835	4	#10-24 x 3/4 SS Screw
46	56002849	4	#10-24 SS Thin Nyl Loc Nut
47	56003123	1	Scr, Soc Set 10-24 x .38
*	56324385	1	Standard Blade Kit
*	56324384	1	Oil Resistant Blade Kit

* = Not Shown

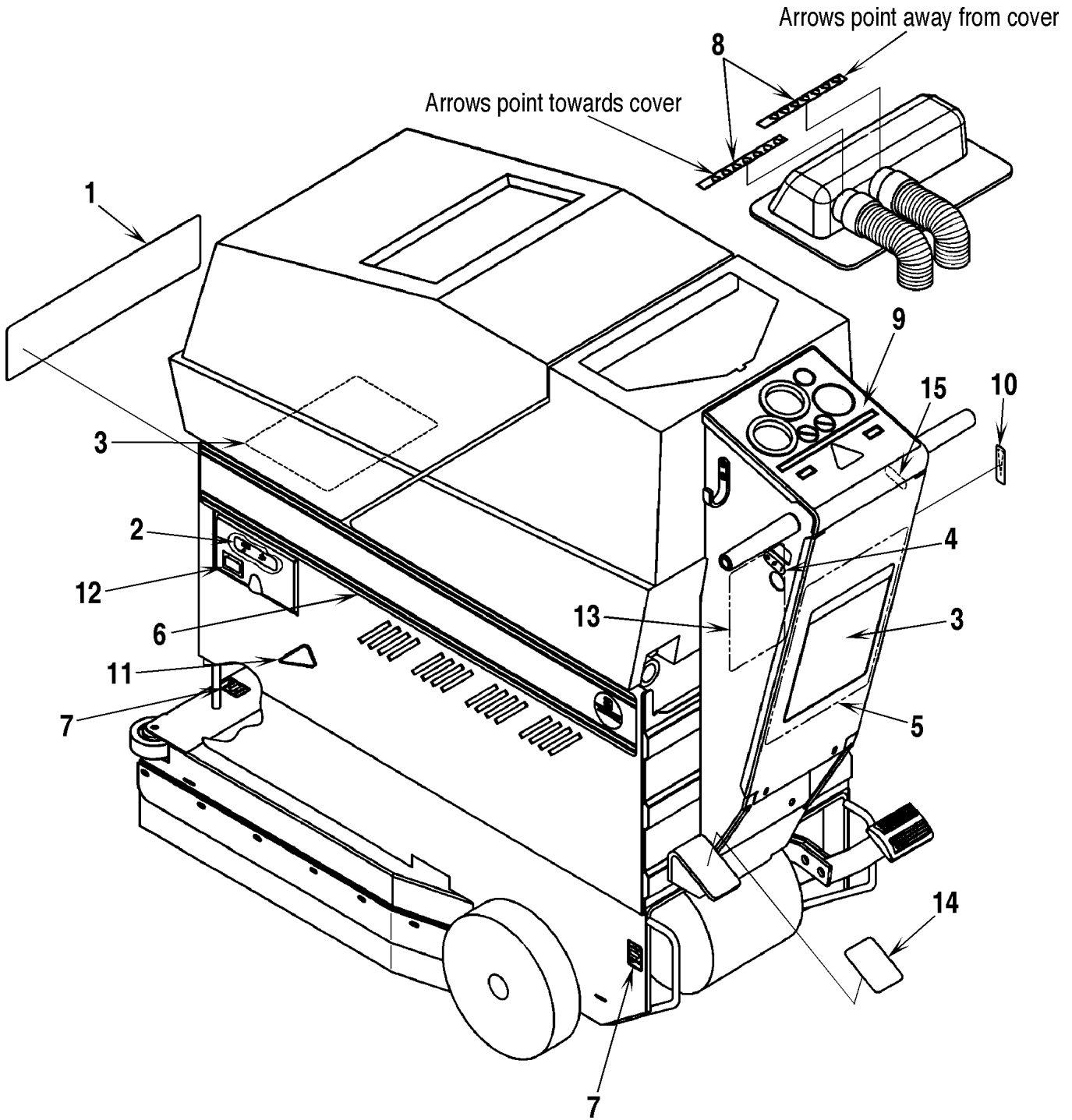

94-12	DECAL SYSTEM-200B / 200LX / 200HD	BOOK E		
01-5	Convertamatic™ 200B/LX / Hydro-Retriever™ 200HD / BA 500	E	3.3.1	31

Item	Ref. No.	Qty	Description
1	56015834	1	Decal, Stripe Front
2	56015526	1	Decal, Reset (200B)
	56015525	1	Decal, Reset (200LX, HD)
3	56014601	2	Decal, Caution
4	56015422	1	Decal, Power
5	56015359	1	Decal, Wiring (200B)
	56015203	1	Decal, Wiring (200LX, HD)
6	56015439	1	Decal, Stripe Left (200B)
	56015437	1	Decal, Stripe Left (200LX)
	56015831	1	Decal, Stripe Left (200HD)
*	56015438	1	Decal, Stripe Right (200B)
*	56015436	1	Decal, Stripe Right (200LX)
*	56015829	1	Decal, Stripe Right (200HD)
7	56015370	4	Decal, Tie Down
8	56015655	2	Decal, Direction
9	56015371	1	Decal, Control (200B)
	56015228	1	Decal, Control (200LX, HD)
10	56016334	1	Decal, Solution Valve
11	56015506	1	Decal, Rotating Brush Hazard
12	56054192	1	Decal, Charger
13	56015414	1	Decal, Batteries
14	56324440	1	Pad, Grip
15	56015487	1	Decal, ON-OFF-ON

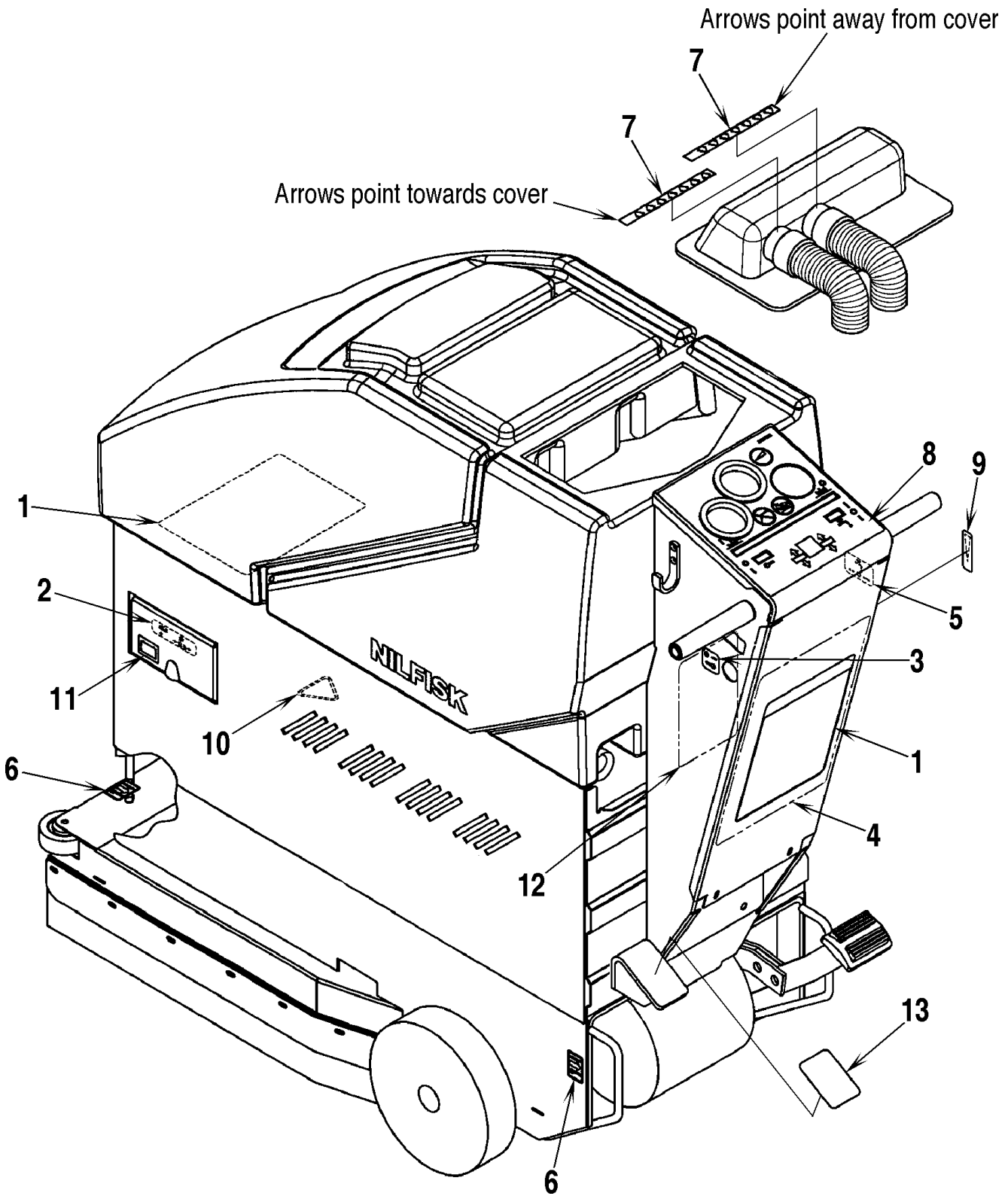

94-12	DECAL SYSTEM-BA 500	BOOK E		
01-5	Convertamatic™ 200B/LX / Hydro-Retriever™ 200HD / BA 500	E	3.3.1	33

Item	Ref. No.	Qty	Description
1	56014601	2	Decal, Caution
2	56015525	1	Decal, Reset
3	56015713	1	Decal, Key On/Off
4	56015203	1	Decal, Wiring
5	56015714	1	Decal, Solution On/Off/On
6	56015370	4	Decal, Tie Down
7	56015655	2	Decal, Direction
8	56015701	1	Decal, Control
9	56016334	1	Decal, Solution Valve
10	56015506	1	Decal, Rotating Brush Hazard
11	56054192	1	Decal, Charger
12	56015388	1	Decal, Cable Routing
13	56324440	1	Pad, Grip

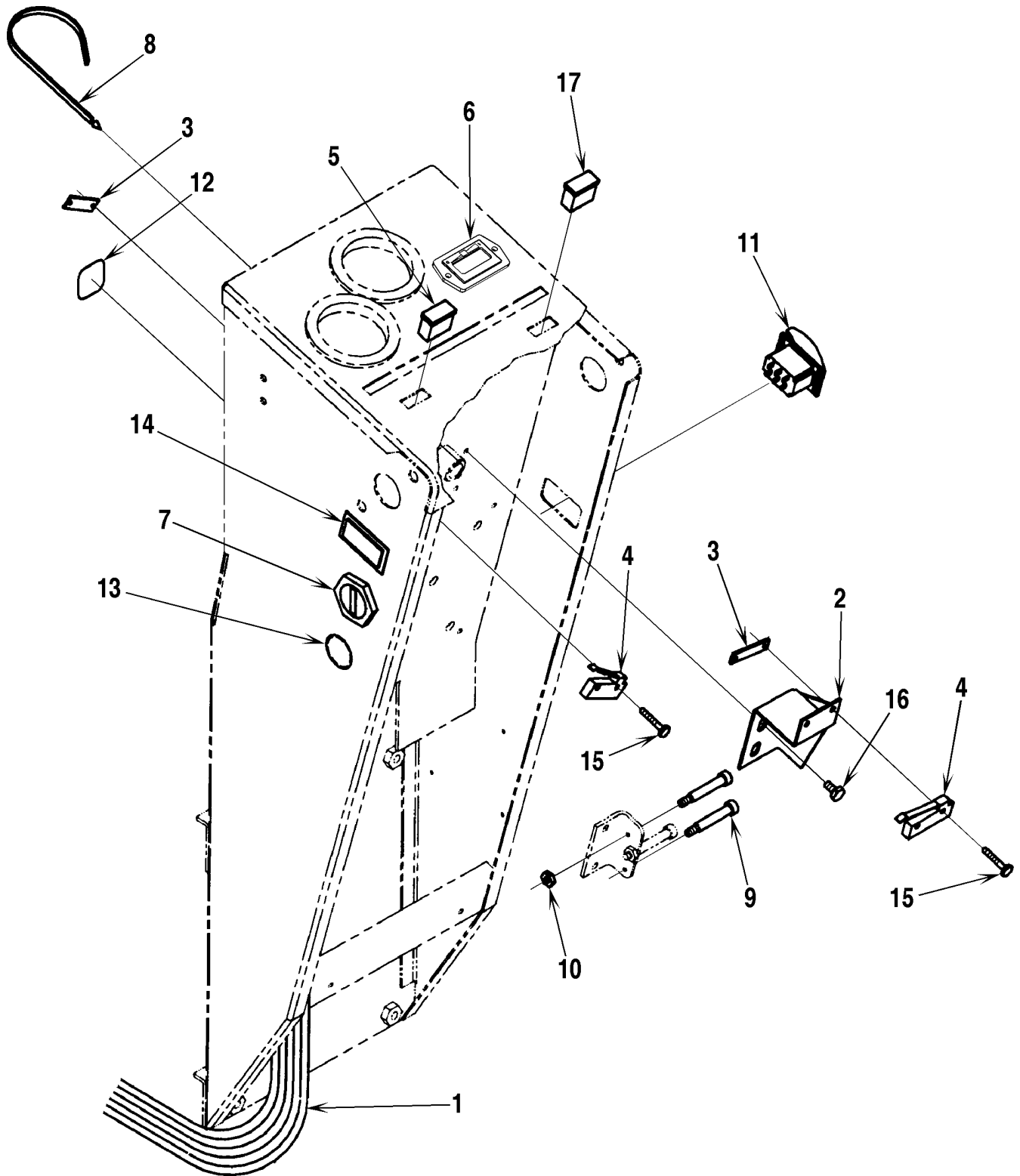

94-12	HANDLE ELECTRICAL SYSTEM-200B	BOOK E		
01-5	Convertamatic™ 200B/LX / Hydro-Retriever™ 200HD / BA 500	E	3.3.1	35

Item	Ref. No.	Qty	Description
1	56324237	1	Wiring Harness
2	56324232	1	Bracket, Switch
3	56376015	1	Nut, Plate
4	56324362	2	Switch
5	56389434	1	Light, Green
6	56372089	1	Meter, Battery
*	56492305	2	Rubber, Boot
7	56393325	1	Bracket, Keylock
*	56301636	1	Toggle Switch
*	56393415	1	Replacement Key for Keylock Bracket
8	56900753	2	Tie, Push Mount
9	56900481	2	Scr, Soc Shd .25 x 1.25 x 10-24
10	56002832	2	Nut, Hex Nyl Loc-Thin 10-24
11	56324272	1	Switch, Rocker
12	56015592	2	Decal, Cover
13	56900144	1	Plug, Cap
14	56260155	1	Plug
15	56003084	4	Scr, Hex Hd Loc 6-32 x 1.00
16	56002519	4	Scr, Hex Hd HP5 10-24 x .38
17	56324028	1	Light, Blue

94-12	HANDLE ELECTRICAL SYSTEM-200LX / 200HD / BA 500	BOOK E		
01-5	Convertamatic™ 200B/LX / Hydro-Retriever™ 200HD / BA 500	E	3.3.1	37

Item	Ref. No.	Qty	Description
1	56324177	1	Wiring Harness
2	56324513	1	Pully
3	56009075	2	#8-32 x 3/8 HP-5 Screw
4	56392859	1	Pully
5	56376015	1	Nut Plate
6	56324362	1	Vacuum Switch
7	56389434	1	Green Light
8	56372089	1	Battery Meter
*	56492305	2	Rubber Boot for Battery Meter
9	56454740	1	Potentiometer 5K Ohm
10	56393325	1	Keylock Bracket
*	56393415	1	Replacement Key for 56393325
*	56301636	1	Main Switch (toggle)
11	56324272	1	Solution Switch
12	56900753	2	Push Mount Tie
13	56009034	2	#8-32 x 7/8 HP-5 Screw
14	56377721	2	Spacer
15	56002834	6	#10-24 x 3/8 Screw
16	56324366	1	Bracket
17	56015592	3	Decal, Cover
18	56009183	2	#10-24 x .19 Loc Set Screw
19	56009184	2	#8-32 x .25 Loc Set Screw
20	56260155	1	Plug
21	56003009	2	#6-32 x 1 Screw
22	56009012	6	#10-24 x 3/8 HP-5 Screw
23	56324022	1	Belt
24	56324023	1	Speed Controller TSB 660
25	56324028	1	Blue Light
26	56324119	1	Potentiometer Bracket
27	56324121	1	Heat Sink
28	56324128	1	Controller Cover
29	56900144	1	Plug

* = Not Shown

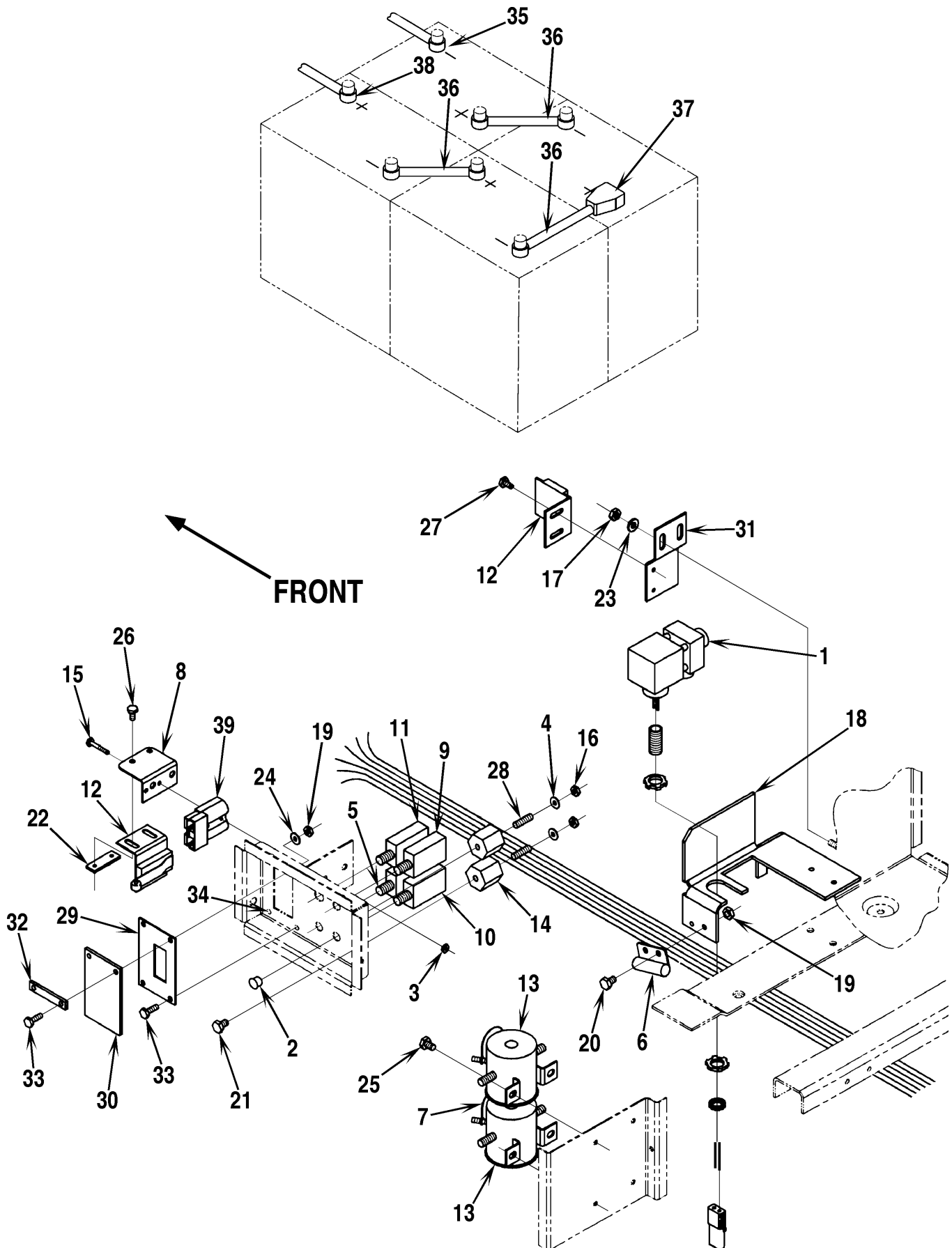

94-12	CHASSIS ELECTRICAL SYSTEM	BOOK E		
01-5	Convertamatic™ 200B/LX / Hydro-Retriever™ 200HD / BA 500	E	3.3.1	39

Item	Ref. No.	Qty	Description
1	56324247	1	Solenoid Valve
2	56493149	1	Plug (200B)
3	56002830	2	Nut, Hex Nyl Loc 6-32 (200B)
	56002708	2	Nut, Hex Nyl Loc 1/4-20 (200LX, 200HD, BA 500)
4	56009064	2	Wsh, Int SHPRF 1/4
5	56387328	1	Circuit Breaker, 5 Amp
6	56324214	1	Switch Assembly
7	56389265	2	Diode (1 on 200LX, 200HD, BA 500)
8	56324308	1	Bracket
9	56395454	1	Circuit Breaker, 20 Amp
10	56395454	1	Circuit Breaker, 20 Amp (200LX, 200HD, BA 500)
11	56454423	1	Circuit Breaker, 30 Amp
12	56462362	2	Switch Assembly
13	56468358	2	Solenoid
14	56469858	2	Stand Off, Insulated
15	56003009	2	Scr, Hex Hd 6-32 x 1.00 (200B)
	56001833	2	Scr, Hex Hd 1/4-20 x 1.50 (200LX, 200HD, BA 500)
16	56009087	2	Nut, Hex Jam 1/4-20
17	56002840	2	Nut, Hex Nyl Loc-Thin 1/4-20
18	56324437	1	Bracket, Solenoid
19	56002768	6	Nut, Hex Nyl Loc 10-24 (4 on 200LX, 200HD, BA 500)
20	56002503	2	Scr, Hex Hd 10-24 x .50
21	56002933	2	Scr, Hex Hd 1/4-20 x .38
22	56324310	1	Nut Plate
23	56002098	2	Wsh, Flt SAE 1/4
24	56001954	4	Wsh, Flt SAE #10 (2 on 200LX, 200HD, BA 500)
25	56009019	4	Scr, Hex Thd Form 1/4-20 x .38
26	56002834	2	Scr, Hex Hd 10-24 x .38
27	56009012	2	Scr, Hex Thd Form 10-24 x .38
28	56150274	2	Stud, 1/4-20
29	56324305	1	Plate (200B)
30	56324086	1	Flap
31	56324062	1	Plate, Switch
32	56324085	1	Strap
33	56002504	4	Scr, Hex Hd 10-24 x .75 (2 on 200LX, 200HD, BA 500)
34	56153699	2	Plug, Button (200LX, 200HD, BA 500)
35	56372526	1	Battery Cable TSB 730
36	56363928	3	Battery Cable TSB 730
37	56372673	8	Boot, Battery
38	56324284	1	Battery Cable TSB 730
39	56324305	1	Charger Plug Housing (200B)
	56324306	2	Charger Plug Contact (200B)
	56100621	1	Charger Plug Housing (200LX, 200HD, BA 500)
	56100623	2	Charger Plug Contact (200LX, 200HD, BA 500)
**	56324307	1	Battery Charger Adapter NOTE 1

NOTE 1: Battery Charger Adapter with (1) small red end and (1) large red end. Use only when switching a machine from its original (STD) batteries to a 2 or 4 battery pack. **IMPORTANT!!:** DO NOT USE THIS ADAPTER TO HOOK UP A 24V, 20 AMP CHARGER TO (2) 12V BATTERIES.

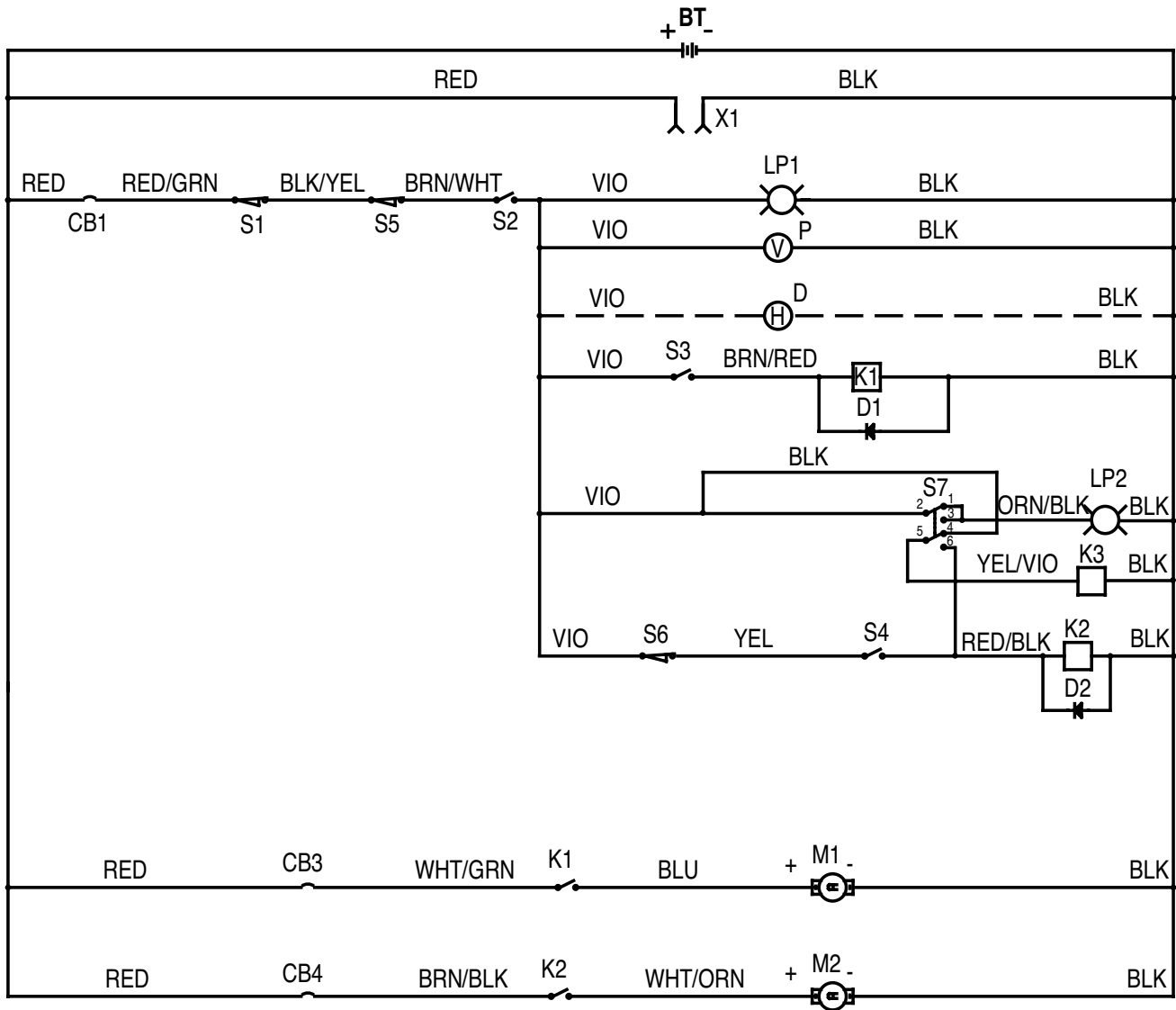

94-12	WIRING DIAGRAM-200B	BOOK E		
01-5	Convertamatic™ 200B/LX / Hydro-Retriever™ 200HD / BA 500	E	3.3.1	41

Item	Ref. No.	Qty	Description
BT	N/A	4	Battery 6V
CB1	56387328	1	Circuit Breaker, 5 Amp
CB3	56395454	1	Circuit Breaker, 20 Amp
CB4	56454423	1	Circuit Breaker, 30 Amp
D			Hour Meter
D1	56389265	1	Diode
D2	56389265	1	Diode
K1	56468358	1	Solenoid (Vacuum Motor)
K2	56468358	1	Solenoid (Brush Motor)
K3	56324247	1	Solenoid Valve (Solution)
LP1	56389434	1	Lamp, Green
LP2	56324028	1	Lamp, Blue
M1	56324189	1	Vacuum Motor
M2	56386261	1	Brush Motor
P	56372089	1	Battery Meter
S1	56462362	1	Charger Interlock Switch
S2	56301636	1	Main switch
S3	56324362	1	Vacuum Motor switch
S4	56462362	1	Brush Motor Switch
S5	56324214	1	Tip Interlock Switch
S6	56324362	1	Brush Switch
S7	56324272	1	Solution Switch
X1	56324305	1	Charger Connector
	56324306	2	Contacts for 56324305

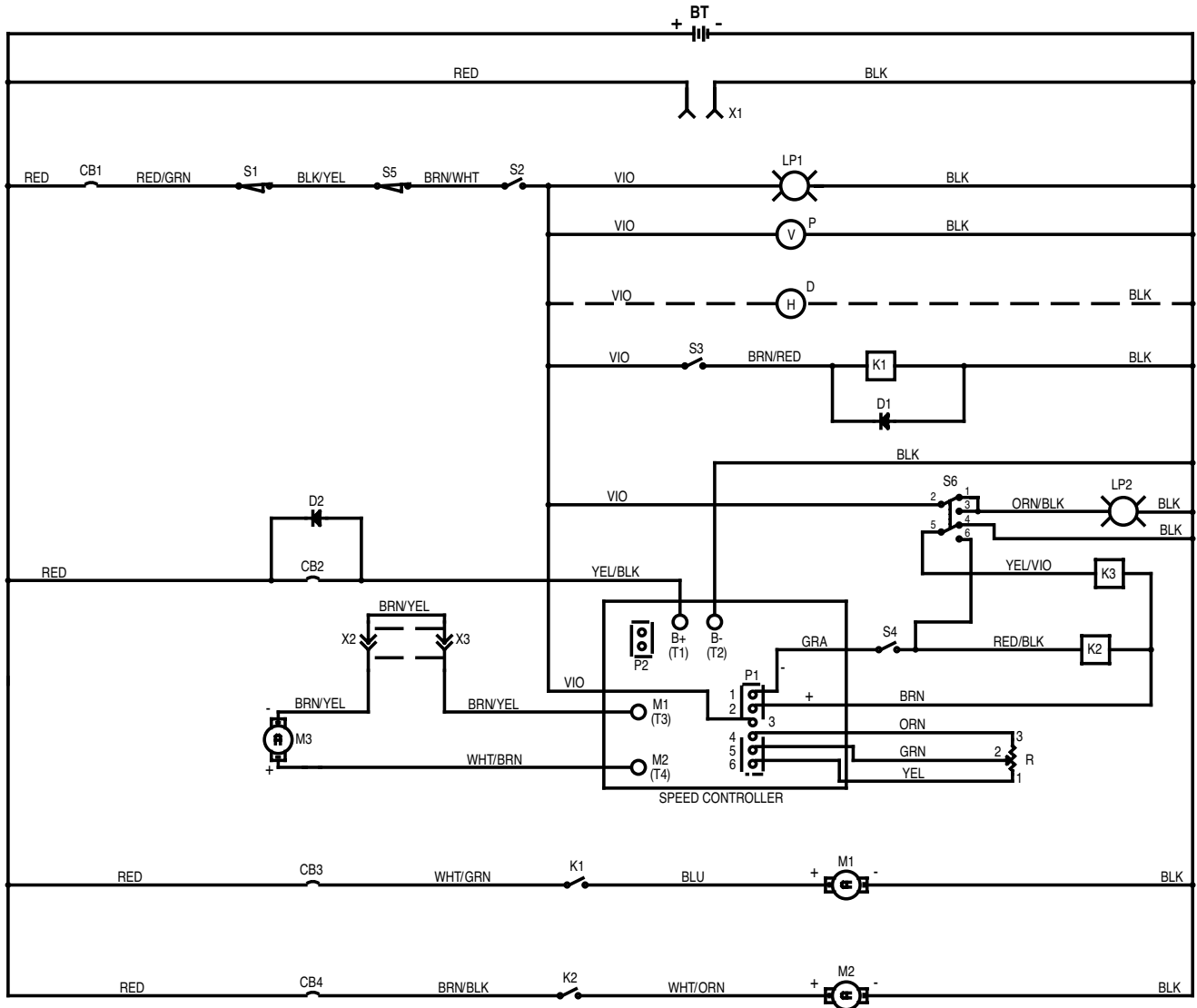

94-12	WIRING DIAGRAM-200LX / 200HD / BA 500	BOOK E		
01-5	Convertamatic™ 200B/LX / Hydro-Retriever™ 200HD / BA 500	E	3.3.1	43

Item	Ref. No.	Qty	Description
	56324023	1	Speed Controller TSB 660
BT	N/A	4	Battery 6V
CB1	56387328	1	Circuit Breaker, 5 Amp
CB2	56395454	1	Circuit Breaker, 20 Amp (Wheel Drive Motor)
CB3	56395454	1	Circuit Breaker, 20 Amp (Vacuum Motor)
CB4	56454423	1	Circuit Breaker, 30 Amp (Brush Motor)
D			Hour Meter
D1	56389265	1	Diode
D2			Diode
K1	56468358	1	Solenoid (Vacuum Motor)
K2	56468358	1	Solenoid (Brush Motor)
K3	56324247	1	Solenoid Valve (Solution)
LP1	56389434	1	Lamp, Green
LP2	56324028	1	Lamp, Blue
M1	56324189	1	Vacuum Motor
M2	56386261	1	Brush Motor
M3	56324011	1	Wheel Drive Motor (BA 500 before SN 1068527)
	56324253	1	Carbon Brush Set for 56324011
	56263253	1	Wheel Drive Motor (BA 500 after SN 1068526 & all 200LX/HD)
	56503023	1	Carbon Brush Set for 56263253
P	56372089	1	Battery Meter
R	56454740	1	Potentiometer, 5K Ohm
S1	56462362	1	Charger Interlock Switch
S2	56301636	1	Main switch
S3	56324362	1	Vacuum Motor switch
S4	56462362	1	Brush Motor Switch
S5	56324214	1	Tip Interlock Switch
S6	56324272	1	Solution Switch
X1	56100621	1	Charger Connector
	56100623	2	Contacts for 56100621
X2			Wheel Drive Disconnect
X3			Wheel Drive Disconnect

We manufacture brushes and pad holders that will give you the best possible performance between machine and floor. Following are descriptions of the materials and their applications when used on the BA 500.

- Union Mix:** Medium grade natural fibers for polishing finished floors with standard-speed equipment. Recommended for use in place of white pads.
- ProLite:** Bristles are made from light-duty polypropylene for general scrubbing when you do not want to scratch or remove finish from the floor. Recommended for use in place of red pads.
- Prolene:** Polypropylene material for medium-duty scrubbing on concrete, terrazzo and vinyl floor tile. Recommended for use in place of green or blue pads.
- Magna Grit:** For extreme heavy-duty scrubbing or stripping of floors. This brush has extra large diameter silicon carbide grit impregnated synthetic bristles. Recommended for use in place of black pads.
- Dyna Grit:** For aggressive, heavy-duty scrubbing or stripping of floors. Recommended for use in place of brown pads.
- MidLite Grit:** For general purpose scrubbing of sealed or unsealed concrete, stone, terrazzo, quarry tile and other resilient hard floor surfaces. Recommended for use in place of green or blue pads.
- MidGrit:** For general purpose scrubbing when you need a lighter action for sealed or unsealed concrete, stone, terrazzo, quarry tile and other resilient hard floor surfaces. Recommended for use in place of green or blue pads.
- AgLite Grit:** For light scrubbing when used wet; buffing or polishing when used dry on urethane coated, sealed concrete or other resilient hard surface floors. Recommended for use in place of red or white pads.
- Short Trim Pad Holder:** Made with a structural foam block and center ring for correct pad centering. It has a "shower feed" design for getting solution to the floor.

- Ref. No.:**
- 56505454 - Union Mix
 - 56505450 - Prolene
 - 56505048 - Dyna Grit
 - 56505083 - MidGrit
 - 56505455 - Short Trim Pad Holder
 - 56505077 - ProLite
 - 56505057 - Magna Grit
 - 56505079 - MidLite Grit
 - 56505063 - AgLite Grit

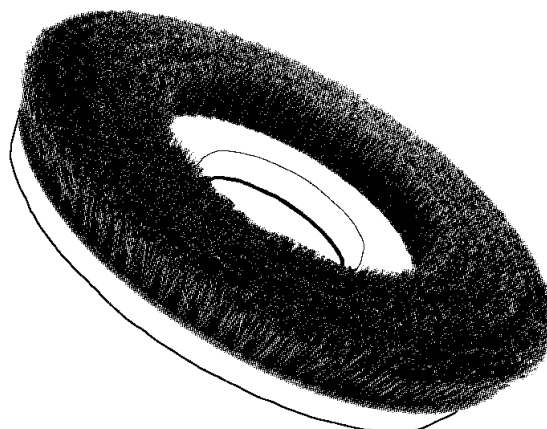

DANMARK

Nilfisk-Advance Nordic A/S
Sognevej 25 - Box 344
DK-2605 Broendby
☎ 43 23 83 50 – Fax 43 42 15 95

NORGE

Nilfisk-Advance AS
Enebakkvn, 119, 0680 Oslo, Postboks 196, Manglerud,
0612 Oslo
☎ 22 08 63 50 – Fax 22 08 63 63
Distriktsrepresentanter over hele landet

SVERIGE

Nilfisk-Advance AB
Sjöbjörnsvägen 5, 117 67 Stockholm
☎ 085 55 944 00 – Fax 085 55 944 30

FINLAND/ SUOMI

BERNER Ltd. Facotek Department
Etäleranta 4B, 00130 Helsinki
☎ +358 9 1345 1382

AUSTRALIA

Nilfisk-Advance Pty. Ltd.
48 Egerton Street
Silverwater NSW 2128
☎ (02) 8748 5905 – Fax (02) 9648 2711
Customer Responce Centre:
☎ 1 800 011 013

BELGIQUE / BELGIË/ LUXEMBOURG

Nilfisk-Advance s.a./n.v.
Doornveld/ Sphere Business Park
Industrie Asse 3, nr 11 – bus 41
1731 Zellik-Asse
☎ (02) 467.60.50 Fax (02) 463.44.16

CANADA

Nilfisk-Advance Ltd.
396 Watline Avenue
Mississauga, Ontario L4Z 1X
☎ (905) 712-3260 – Fax (905) 712-3255

DEUTSCHLAND

Nilfisk-Advance AG
Siemensstraße 25-27
25462 Rellingen
☎ (041 01) 3990 – Fax (04101) 399191
Zentraler Kundenservice
☎ für die Industrie: 0180 535 67 97
☎ Institutionen und Gebäudereiniger: 0180 500 11 70

FRANCE

Nilfisk-Advance S.A.
BP 246
91944 Courtaboeuf Cedex
☎ (01) 69.59.87.00 Télécopie (01) 69.59.87.01

HONG KONG

Nilfisk-Advance Ltd.
2001, 20/F HK Worsted Mills
Industrial Building
31-39 Wo Tong Tsui Street
Kwai Chung, N.T.
☎ 2427 59 51 – Fax 2487 5828

IRELAND

Nilfisk-Advance Ltd.
28 Sandford Office Park
Dublin 18
☎ +353 1 2943838 – Fax +353 1 2943845

JAPAN

Nilfisk-Advance Inc.
3-4-9 Chigasaki Minami
Tsuzuki-Ku Yokohama 224 0037
☎ 045-942-7741 – Fax 045-942-6545

MALAYSIA

Nilfisk-Advance Sdn Bhd
Lot 2, 1st. Floor
Lorong 19/1A
46300 Petaling Jaya
Selangor Darul Ehsan
☎ 03-7568188/03-7568189/03-7568388 – Fax 03-7566828

NEDERLAND

Nilfisk-Advance B.V.
Flevolaan 7, Postbus 341
1380 AH Weesp
☎ 0294-462121 – Fax 0294-430053

NEW ZEALAND

Nilfisk-Advance Limited
477 Great South Road, Penrose
Auckland
☎ (09) 525 0092 – Fax (09) 525 6440

SCHWEIZ / SUISSE

Nilfisk-Advance AG
Ringstrasse 19, 9533 Kirchberg/Wil
☎ 719 23 52 83 – Fax 719 23 84 44

SINGAPORE

Nilfisk-Advance Pte. Ltd.
22, Woodlands Industrial Park E1
Singapore 757740
☎ (65) 759 9100 – Fax (65) 759 9133

TAIWAN

Nilfisk-Advance Ltd.
1 F, No.23, Lane 132, Sec. 2
Ta An Road, Taipei
☎ 700 22 68 – Fax 784 08 43

UNITED KINGDOM

Nilfisk-Advance Limited
Newmarket Road
Bury St. Edmunds
Suffolk IP 33 3SR
☎ (01284) 763163 – Fax (01284) 750562

USA

Nilfisk-Advance Inc.
14600 21st Avenue North
Plymouth, MN 55447-3408
☎ +1 800 989 2235 – Fax 1 800 989 6566

Nilfisk-Advance of America, Inc.
300 Technology Drive
Malvern, PA 19355
☎ (610) 647 647-6427

ÖSTERREICH

Nilfisk-Advance GmbH
Vorarlberg Allee 46
1230 Wien
☎ 1 616 58 30 – Fax 1 616 58 30 40

ESPAÑA

Nilfisk-Advance, S.A.
Torre D'Ara
Passeig del Rengle, 5 Pl.9-10
E-08302 – Mataró (Barcelona)
☎ Tel. 93 741 24 00 – Fax: 93 757 80 20
Central atención al cliente: 902 200 201
nilfisk@nilfisk-advance.es – www.nilfisk-advance.com
Distribuidores y Servicio Técnico en toda España y Andorra

ITALIA

Nilfisk-Advance Italia Spa
Località Novella Terza
26862 Guardamiglio (LO)
Italy
☎ +39 0377 414067-54 – Fax +39 0377 414097
www.nilfisk-advance.com

PORTUGAL

Nilfisk-Advance Lda.
Rua Cândido de Figueiredo, 91-i, 1500-133 LISBOA
☎ 01/7784142 – Fax 01/7785613
Porto 02/526766 – Fax 02/520739
Açores 096/628092/3 – Fax 096/628129
Madeira 091/228965 – Fax 091/228796

GREECE

Embiom S.A.
Λεωφ. Βουλιαγμένης 60
Αργυρούπολη
164 52 Αθήνα
☎ 9950613 - Fax 9951680



Material composition of the Nilfisk BA 500

