



# Electronic Service Manuals

This electronic document is provided as a service to our customers. We do not create the contents of the information contained in this document. Should you have detailed questions pertaining to the information contained in this document, you may contact Michco, or the manufacturer which provided the original information in this electronic deliverable. Michco's only part in this electronic deliverable was the electronic assembly process.

You may contact Michco through the following methods:  
Phone (517) 484-9312 or (800) 331-3339 MI, OH, IN only  
2011 N. High St. -- Lansing, Michigan -- 48906  
Fax: (517) 484-9836  
Email: [CustServ@Michco.com](mailto:CustServ@Michco.com)  
Web site: [www.Michco.Com](http://www.Michco.Com)  
Parts Web site: [www.FloorMachineParts.Com](http://www.FloorMachineParts.Com)

Order Parts on Line at:  
**[www.FloorMachineParts.Com](http://www.FloorMachineParts.Com)**

Directly to Parts & Service:  
By Email: **[Shop@Michco.com](mailto:Shop@Michco.com)**  
By Fax: (517) 702-2041  
By Voice: Use numbers above.

**Serving the Cleaning Industry Since 1922**

Notice: All copyrighted material remains property of original owners, all trademarks are property of respective owners. Manuals are subject to Manufacturer's reproduction limitations. Originals or reproductions were provided by manufacturers through a request. We make no warranty as to the correctness of information provided in this document and you assume all risk.

# Convertamatic™ 200E

---



## **PARTS LIST**

**Advance MODELS 56324004(120V)**

**56324006(230V / OBSOLETE)**

**This parts list is for machines after serial number 0533401**



# Advance



DESCRIPTION	PAGE
Control Handle .....	4-5
Chassis System .....	6-7
Vacuum Motor System (before SN 1087006) .....	8-9
Vacuum Motor System (after SN 1087005, except SN 1087971 - SN 1088010) .....	10-11
Brush Drive System .....	12-13
Axle System .....	14-15
Solution System .....	16-17
Recovery Tank System .....	18-19
Squeegee System (before serial #0536425) .....	20-21
Squeegee System (after serial #0536424) .....	22-23
Decal System .....	24-25
Handle Electrical System .....	26-27
Chassis Electrical System .....	28-29
Wiring Diagram - 115V .....	30-31
Wiring Diagram - 240V .....	32-33

**WHEN ORDERING PARTS**

- \* Use the 8 digit numbers from the "Ref. No." columns in this parts list.
- \* Specify the model and serial number of the machine.
- \* Use the space below to record the model and serial number for future reference.

Model \_\_\_\_\_ Serial No. \_\_\_\_\_

**CONTROL HANDLE**  
**Convertamatic™ 200E**

4

01-6

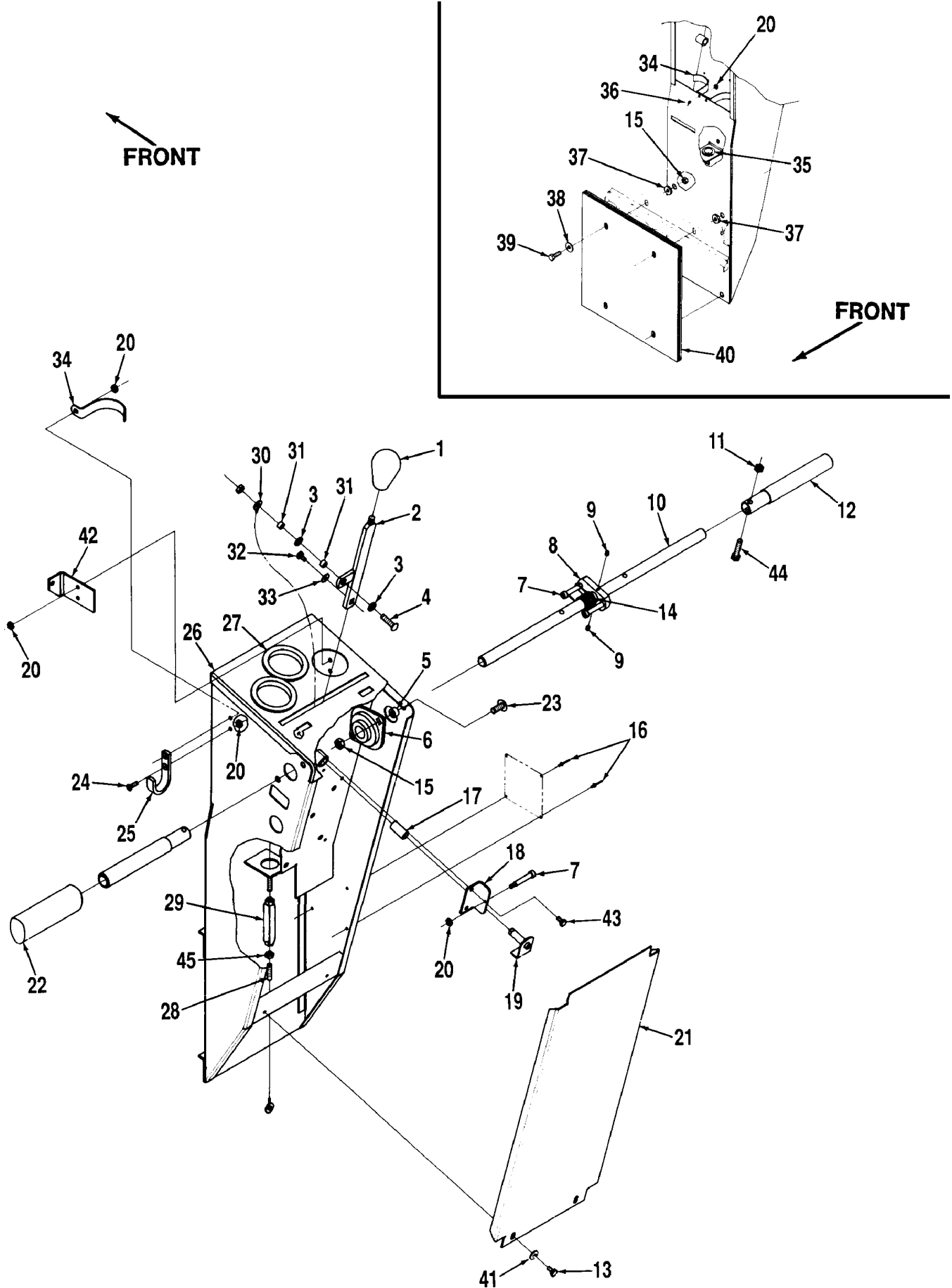

**CONTROL HANDLE**

01-6

**Convertamatic™ 200E****5**

Item	Ref. No.	Qty	Description
1	56364527	1	Knob
2	56324129	1	Handle
3	56002098	2	1/4 Flat Washer
4	56002292	1	1/4-20 x 1-1/4 Pan Hd Screw
5	56320595	4	Bushing
6	56393264	2	Bearing
7	56900481	3	Shoulder Screw
8	56324133	1	Spring Lever
9	56001931	2	#10-24 x 3/16 Set Screw
10	56324131	1	Handle
11	56002708	3	1/4-20 Nyl Loc Nut
12	56324120	2	Tube
13	56002519	2	#10-24 x 3/8 HP-5 Screw
14	56324033	1	Torsion Spring
15	56002701	8	5/16-18 Nyl Loc Nut
16	56261209	4	Pop Rivet
17	56200972	1	Bearing
18	56324132	1	Stop Bracket
19	56324361	1	Actuator
20	56002768	5	#10-24 Nyl Loc Nut
21	56324130	1	Cover
22	56388545	2	Grip
23	56002920	4	5/16-18 x 3/4 Pan Hd Screw
24	56002099	2	#10-24 x 5/8 Flat Hd Screw
25	56324349	2	Hook
26	56324111	1	Handle
27	56324195	2	Grommet
28	56324326	1	Wire Rope (lower)
29	56206814	1	Turnbuckle
30	56324036	1	Wire Rope (upper)
31	56379298	2	Bushing
32	56002926	1	#10-24 x 3/8 Screw
33	56203874	1	Washer
34	56180030	3	Clamp
35	56491648	1	Bearing
36	56002043	2	#10-24 x 3/8 Pan Hd Screw
37	56151807	2	Washer
38	56001939	4	5/16 Flat Washer
39		4	5/16-18 x 2-1/4 Bolt
40	56324312	6	Weight
41	56001954	2	#10 Flat Washer 115V
42	56324280	1	Bracket
43	56002532	2	#10-24 x 1/2 HP-5 Screw
44	56002093	2	1/4-20 x 1 Screw
45	56002840	1	1/4-20 Nyl Loc Nut

CHASSIS SYSTEM

6

Convertamatic™ 200E

01-6

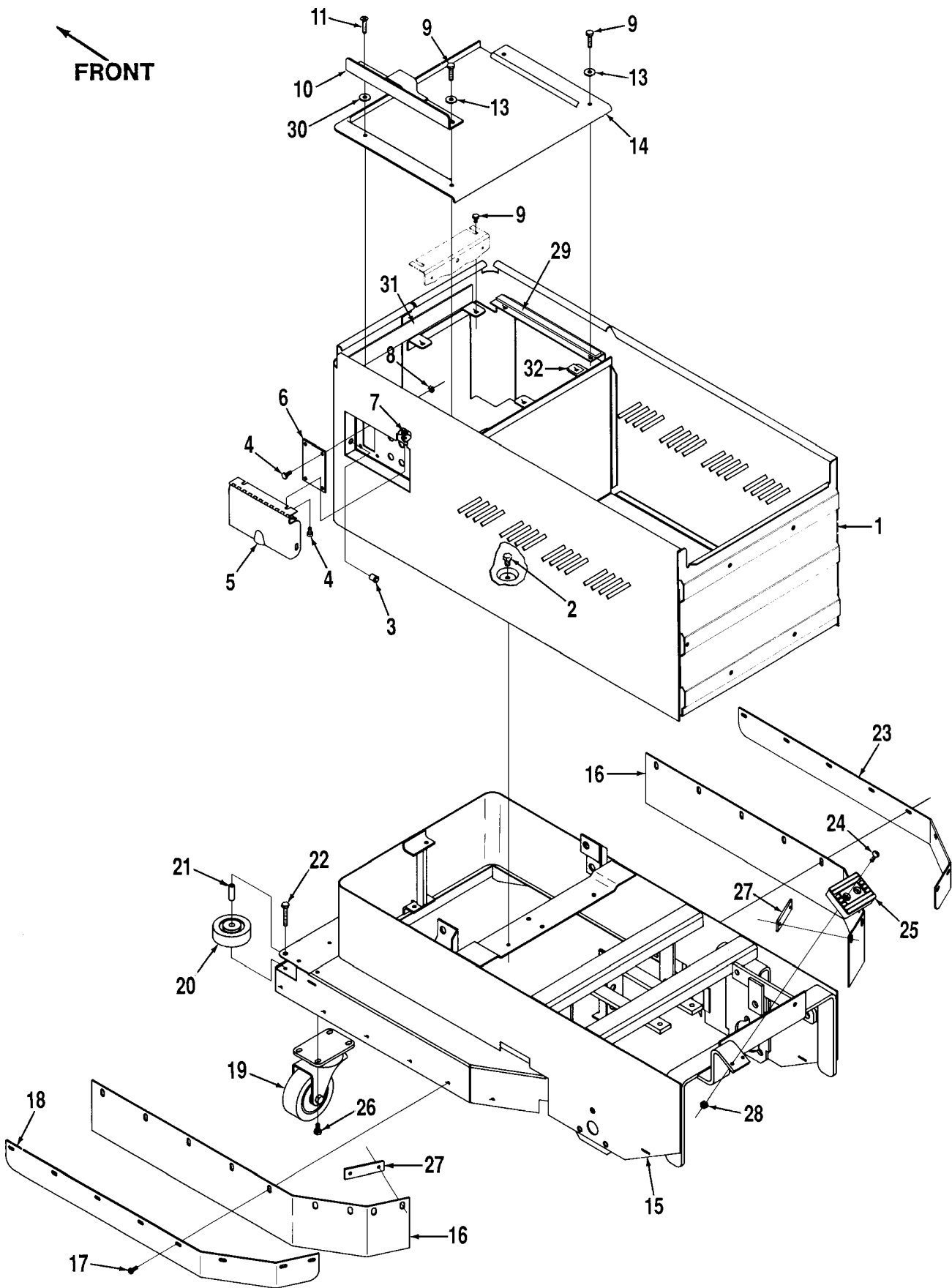

**CHASSIS SYSTEM**

01-6

**Convertamatic™ 200E****7**

Item	Ref. No.	Qty	Description
1	56324064	1	Battery Case
2	56001862	2	5/16-18 x 1/2 Bolt
3	56361321	2	Bullet Catch
4	56002043	6	#10-24 x 3/8 Screw
5	56324078	1	Cover
6	56324292	1	Cover
7	56002768	2	#10-24 Nyl Loc Nut
8	56002832	4	#10-24 Nyl Loc-Thin Nut
9	56002729	7	1/4-20 x 1/2 Loc Screw
10	56324072	1	Support Bracket
11	56002921	1	1/4-20 x 1/2 Fit Hd Screw
12			<b>Omitted Intentionally</b>
13	56900737	3	Sealing Washer
14	56324300	1	Cover
15	56324153	1	Chassis
16	56382905	2	Skirt
17	56002900	16	#10-24 x 1/2 SS HP-5 Screw
18	56324286	1	Left Strap
19	56206725	2	Caster
20	56324350	2	Wheel
21	56360139	2	Bushing
22	56002537	2	1/4-20 x 1-1/2 HP-5 Screw
23	56324287	1	Right Strap
24	56002292	2	1/4-20 x 1 Pan Hd Screw
25	56365082	1	Rubber Pad
*	56365081	1	Plate
*	56365083	1	Pedal Cup
26	56002513	8	1/4-20 x 1/2 HP-5 Screw
27	56324220	2	Bar
28	56002708	2	1/4-20 Nyl Loc Nut
29	56209434	9"	Gasket (23.13 cm)
30	56324374	1	Sealing Washer
31	56324373	1	Gasket
32	56321520	8	Clamp Nut

\* = Not Shown

FRONT

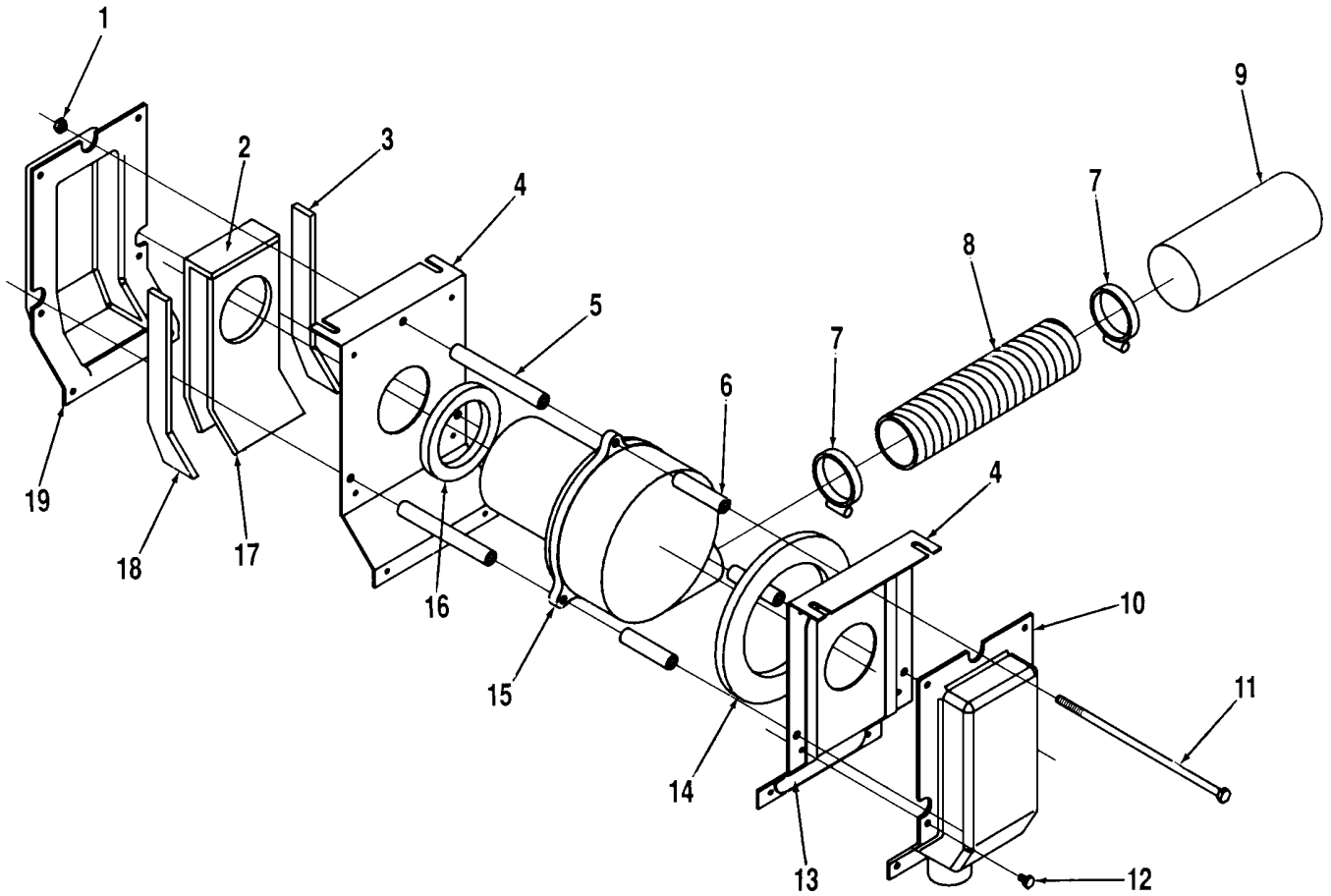

**VACUUM MOTOR SYSTEM (BEFORE SN1087006)**

02-9

**Convertamatic™ 200E****9**

Item	Ref. No.	Qty	Description
1	56002708	3	Nut, Hex Nyl Loc 1/4-20
2	56324101	1	Foam
3	56324099	1	Foam
4	56324098	2	Vacuum Motor Bracket
5	56324094	3	Spacer
6	56324095	3	Spacer
7	56440213	2	Hose Clamp
8	56385599	1	Hose
9	56391807	1	Foam
10	56324097	1	Shroud
11	56002776	3	1/4-20 x 8 Screw
12	56002519	12	#10-24 x 3/8 HP-5 Screw
13	56200754	5'	Gasket (1.5 m)
14	56385437	1	Gasket
15	56324263	1	Vacuum Motor 115V
	56324344	1	Vacuum Motor 240V
16	56324040	1	Gasket
17	56324102	1	Foam
18	56324100	1	Foam
19	56324092	1	Shroud

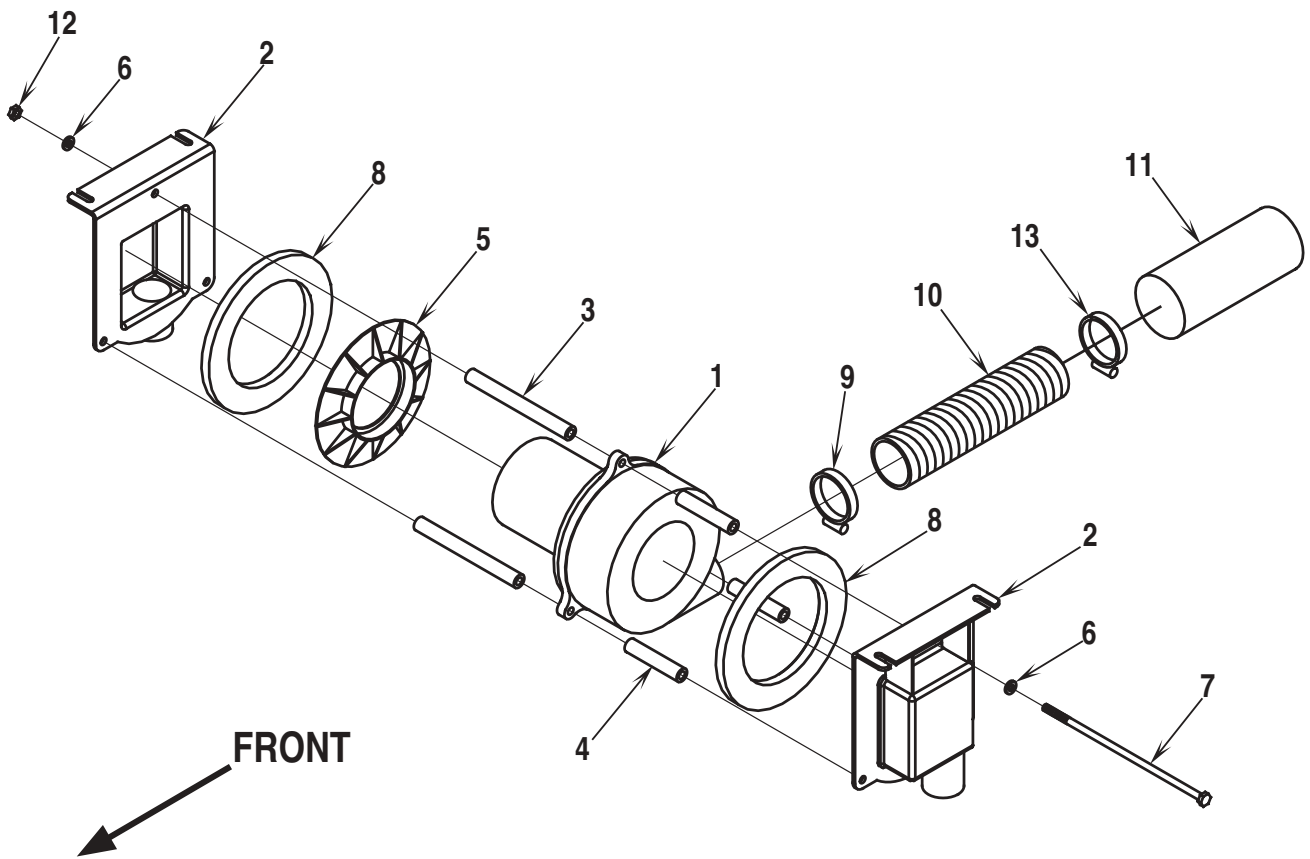

**VACUUM MOTOR SYSTEM (AFTER SN1087005\*)**

02-9

**Convertamatic™ 200E****11**

Item	Ref. No.	Qty	Description
1	56324263	1	Vacuum Motor 115V
	56324344	1	Vacuum Motor 240V
2	56324458	2	Shroud
3	56324461	3	Spacer
4	56324462	3	Spacer
5	56324459	1	Flange
6	56002098	6	Wsh, Flt SAE 1/4
7	56002776	3	Scr, Hex Hd 1/4-20 x 8.00
8	56385437	2	Gasket
9	56440213	1	Hose Clamp
10	56324358	1	Hose
11	56324359	1	Foam, Accoustical
12	56002708	3	Nut, Hex Nyl Loc 1/4-20
13	56477613	1	Cable Tie

\* **NOTE:** Except SN 1087971 through 1088010.

FRONT

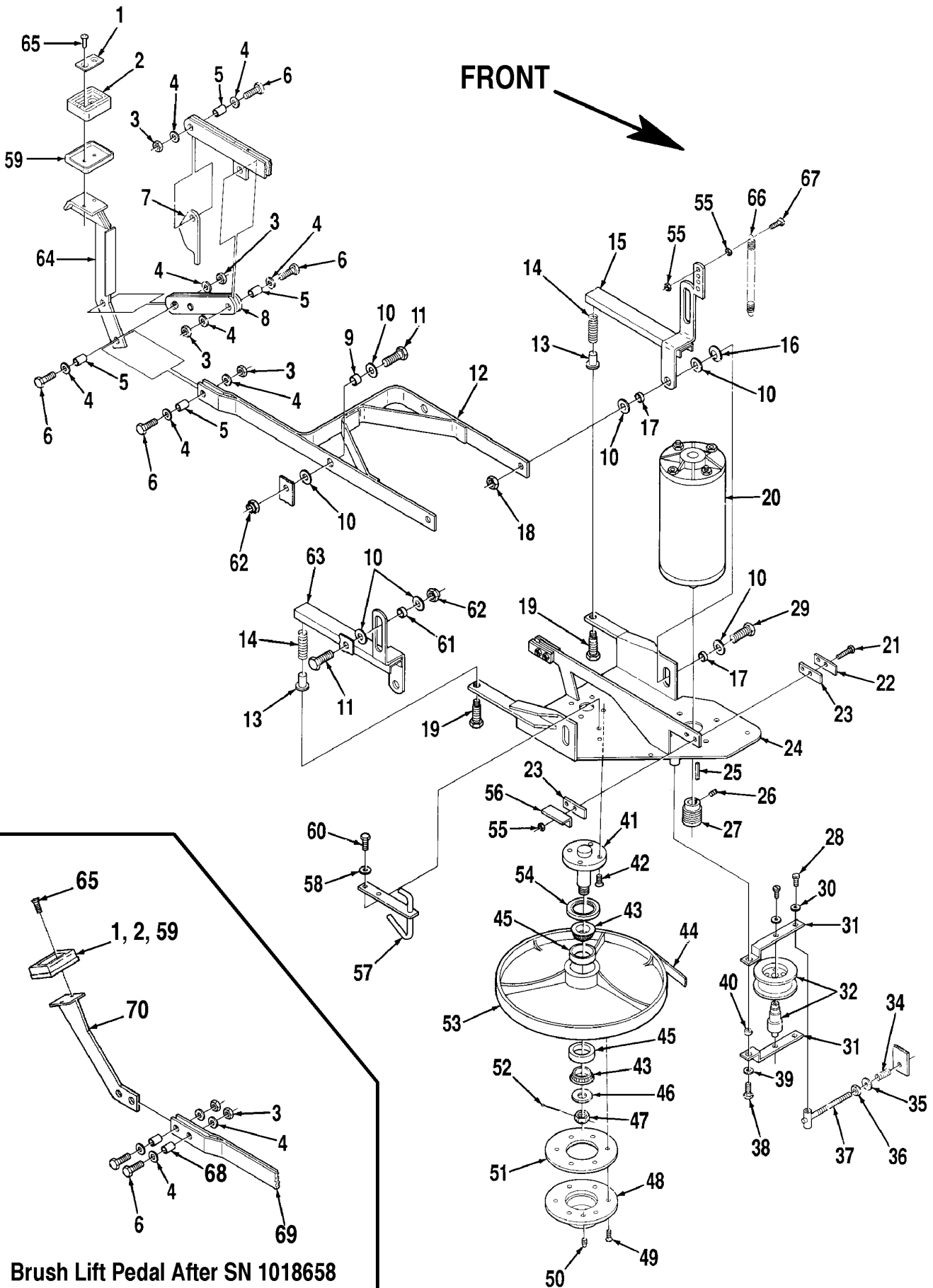

Brush Lift Pedal After SN 1018658

# BRUSH DRIVE SYSTEM

01-6

Convertamatic™ 200E

13

Item	Ref. No.	Qty	Description	Item	Ref. No.	Qty	Description
1	56365081	1	Plate	53	56171376	1	Pulley
2	56365082	1	Rubber Pad	54	56171078	1	Seal
3	56002769	4	3/8-16 Nyl Loc Nut	55	56002708	6	1/4-20 Nyl Loc Nut
4	56002063	8	3/8 Flat Washer	56	56382984	1	Bracket
5	56324200	4	Bushing (before SN 1018659)	57	56385776	1	Solution Pipe
6	56001858	4	3/8-16 x 1-1/4 Bolt	58	56151114	2	Washer
7	56324058	1	Lock Plate (before SN 1018659)	59	56365083	1	Pedal Cup
8	56324201	1	Linkage (before SN 1018659)	60	56002514	2	1/4-20 x 3/4 HP-5 Screw
9	56360627	2	Bushing	61	56365030	2	Bushing
10	56009017	14	Washer	62	56002770	4	1/2-13 Nyl Loc Nut
11	56001968	4	1/2-13 x 1-1/2 Bolt	63	56385890	1	Bracket
12	56324050	1	Brush Linkage (before SN 1018659)	64	56324054	1	Pedal (before SN 1018659)
13	56386216	2	Guide Bushing	65	56002784	2	1/4-20 x 3/4 Flat Hd Screw
14	56373869	2	Spring	66	56398606	1	Spring
15	56385893	1	Bracket	67	56001821	1	1/4-20 x 7/8 Screw
16	56009130	2	Bowed Washer	68	56244859	2	Bushing (after SN 1018658)
17	56382086	4	Bushing	69	56324380	1	Brush Linkage (after SN 1018658)
18	56002843	2	1/2-13 Nyl Loc Nut	70	56324386	1	Pedal (after SN 1018658)
19	56386213	2	Adjusting Bolt				
20	56385630	1	Brush Drive Motor 3/4 hp 115V	**	56505058	1	Magna Grit™ 46 Brush
	56387009	1	Brush Drive Motor 3/4 hp 240V	**	56505048	1	Dyna Grit™ 80 Brush
21	56001878	4	1/4-20 x 1-1/4 Screw	**	56505079	1	MidLite Grit™ 180 Brush
22	56386160	3	Plate	**	56505083	1	MidGrit™ 240 Brush
23	56386105	4	Wear Strip	**	56505063	1	AgLite™ 500 Brush
24	56385662	1	Bracket	**	56505450	1	Prolene Brush
25	56443719	1	3/16 x 1-3/8 Key	**	56505077	1	ProLite™ Brush
26	56001841	2	1/4-2 x 1-1/4 SS Set Screw	**	56505454	1	Union Mix Brush
27	56171088	1	Sheave	**	56505455	1	Short-Trim Pad Holder
28	56002043	4	#10-24 x 3/8 Screw				
29	56001831	2	1/2-13 x 1-1/4 Bolt	**	56505921	1	Magna Grit™ 46 Brush
30	56001954	4	#10 Flat Washer	**	56505922	1	Dyna Grit™ 80 Brush
31	56386290	2	Bracket	**	56505928	1	MidLite Grit™ 180 Brush
32	56171734	1	Idler Assembly	**	56505927	1	MidGrit™ 240 Brush
	56171735	1	Pulley	**	56505923	1	AgLite™ 500 Brush
	56171733	1	Shaft	**	56505924	1	Prolene Brush
33			<b>Omitted Intentionally</b>	**	56505925	1	ProLite™ Brush
34	56171271	1	Spring	**	56505926	1	Union Mix Brush
35	56001939	1	5/16 Flat Washer	**	56505920	1	Short-Trim Pad Holder
36	56002025	1	5/16-18 Jam Nut	**	56505280	1	Level-Set Pad Holder
37	56386273	1	Linkage				
38	56001821	1	1/4-20 x 7/8 Screw	**	56182058	A/R	"Pad Grab" Pad Retainer ( <b>snap in</b> )
39	56002098	1	1/4 Flat Washer	**	56393567	A/R	"Big Mouth" Pad Retainer ( <b>threaded</b> )
40	56368989	1	Bushing	**	56506001	A/R	Clutch Plate ( <b>Silver/NP-47</b> )
41	56171056	1	Shaft	**	56506006	A/R	Clutch Plate ( <b>Plastic/NP-92</b> )
42	56002517	4	1/4-20 x 3/4 HP-5 Screw				
43	56378267	2	Bearing	*			* = Not Shown
44	56171200	1	Belt	**			** = Optional Accessory, Not Included
45	56378259	2	Bearing Race				
46	56163449	1	Washer				
47	56158313	1	Nut				
48	56163430	1	Drive Cap <b>TSB 628, G-10</b> <b>(Silver/NP-47)</b>				
	56163431	1	Drive Cap <b>(Gold/NP-92)</b>				
49	56002569	6	#10-24 x 1/2 Flat Hd HP-5 Screw				
50	56361321	1	Catch				
51	56158275	1	Gasket				
52	56001882	1	1/16 x 1 Cotter Pin				

←  
FRONT

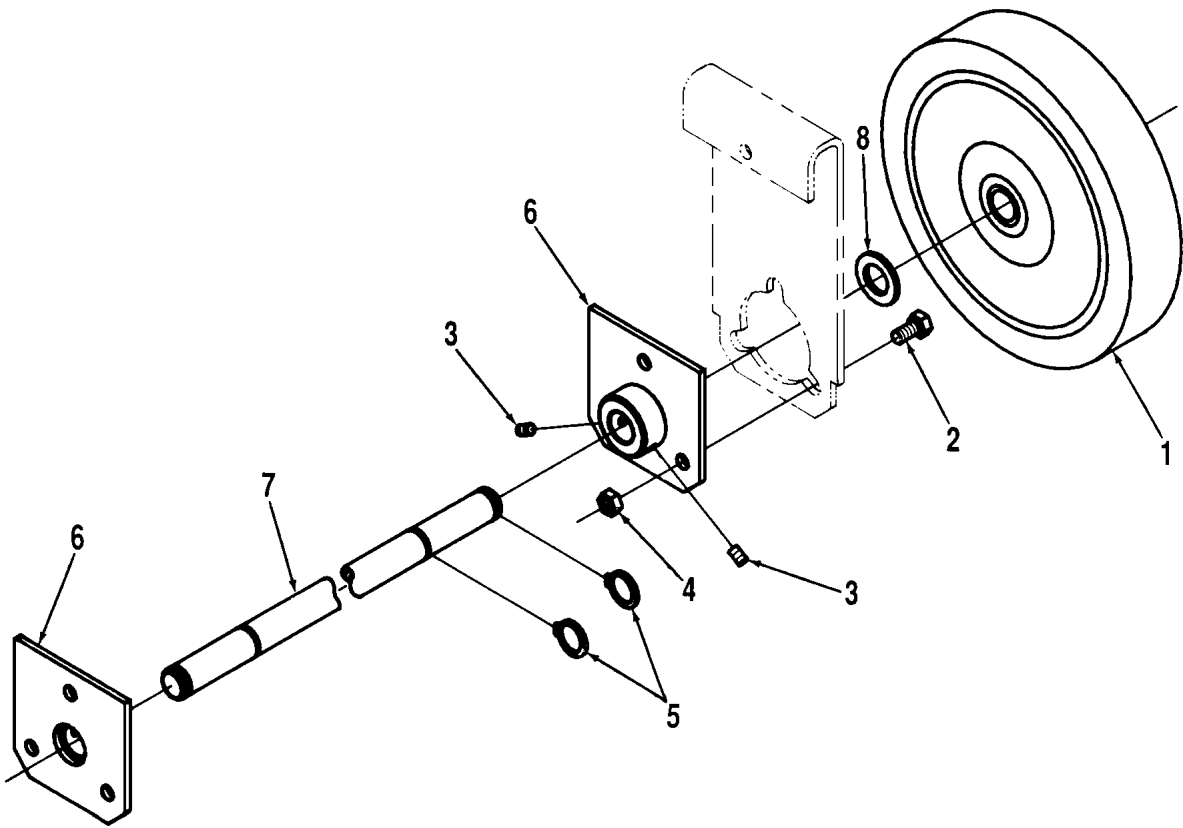

**AXLE SYSTEM**

01-6

**Convertamatic™ 200E****15**

Item	Ref. No.	Qty	Description
1	56377945	2	Wheel (with Bearings)
*	56362352	2	Wheel Bearings only
2	56002035	6	5/16-18 x 5/8 Bolt
3	56002930	4	1/4-20 x 3/8 Set Screw
4	56002701	6	5/16-18 Nyl Loc Nut
5	56900884	4	Retaining Ring
6	56324230	2	Axle Mount
7	56324231	1	Axle
8	56367192	2	Washer

\* = Not Shown

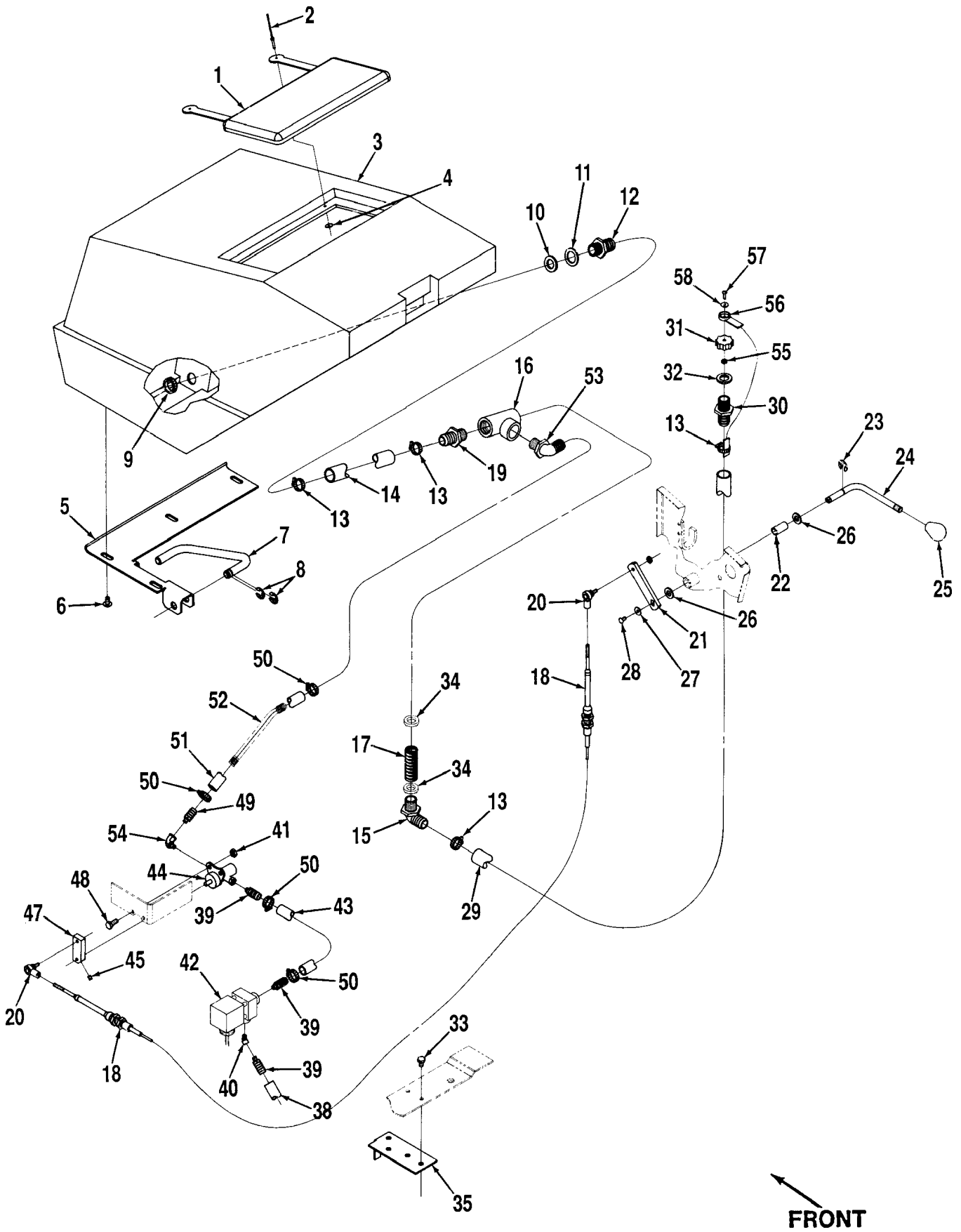

**SOLUTION SYSTEM**

01-6

**Convertamatic™ 200E**

**17**

Item	Ref. No.	Qty	Description	Item	Ref. No.	Qty	Description
1	56386062	1	Cover Assembly	33	56001861	2	1/4-20 x 3/8 Screw
	56386166	1	Cover	34	56324313	2	Rubber Washer
	56263379	2	Strap	35	56324241	1	Bracket
2	56900186	4	Pop Rivet	36			<b>Omitted Intentionally</b>
3	56324211	1	Solution Tank	37			<b>Omitted Intentionally</b>
	56324193	1	Solution Tank Assembly (#1-12)	38	56324043	1	Hose
4	56263381	2	Washer	39	56155640	3	Barb
5	56324077	1	Panel	40	56368938	1	Elbow
6	56002924	4	1/4-20 x 1/2 Screw	41	56002708	4	1/4-20 Nyl Loc Nut
7	56324076	1	Prop Rod	42	56324267	1	Solenoid Valve 115V
8	56324204	2	Retaining Ring		56324342	1	Solenoid Valve 240V
9	56393187	1	Nut	43	56324042	1	Hose
10	56249625	1	Restrainer	44	56368903	1	Solution Valve
11	56154717	1	Rubber Washer	45	56002015	1	#10-24 x 1/4 Set Screw
12	56393182	1	Barb	46			<b>Omitted Intentionally</b>
13	56112771	4	Hose Clamp	47	56324089	1	Handle
14	56324041	1	Hose	48	56001836	2	1/4-20 x 5/8 Screw
15	56456802	1	Barb	49	56373456	1	Barb
16	56324029	1	Tee	50	56219932	4	Hose Clamp
17	56324030	1	Filter	51	56324249	1	Hose
18	56324205	1	Cable	52	56471103	1	Spring
19	56900292	1	Barb	53	56324035	1	Barb
20	56488290	2	Ball Joint	54	56369632	1	Elbow
21	56324206	1	Link	55	56002877	1	#8-32 SS Nyl Loc Nut
22	56200972	1	Bearing	56	56324257	1	Strap
23	56321427	1	Retaining Ring	57	56002876	1	#8-32 x 1/2 SS Screw
24	56324216	1	Handle	58	56002875	1	#8 SS Flat Washer
25	56378534	1	Knob				
26	56002063	2	3/8 Flat Washer				
27	56203874	1	#10 Flat Washer				
28	56002926	1	#10-24 x 3/8 Screw				
29	56324291	1	Drain Hose				
30	56900273	1	Barb				
31	56324256	1	Cap				
32	56368776	1	Rubber Washer				

RECOVERY TANK SYSTEM

18

Convertamatic™ 200E

01-6

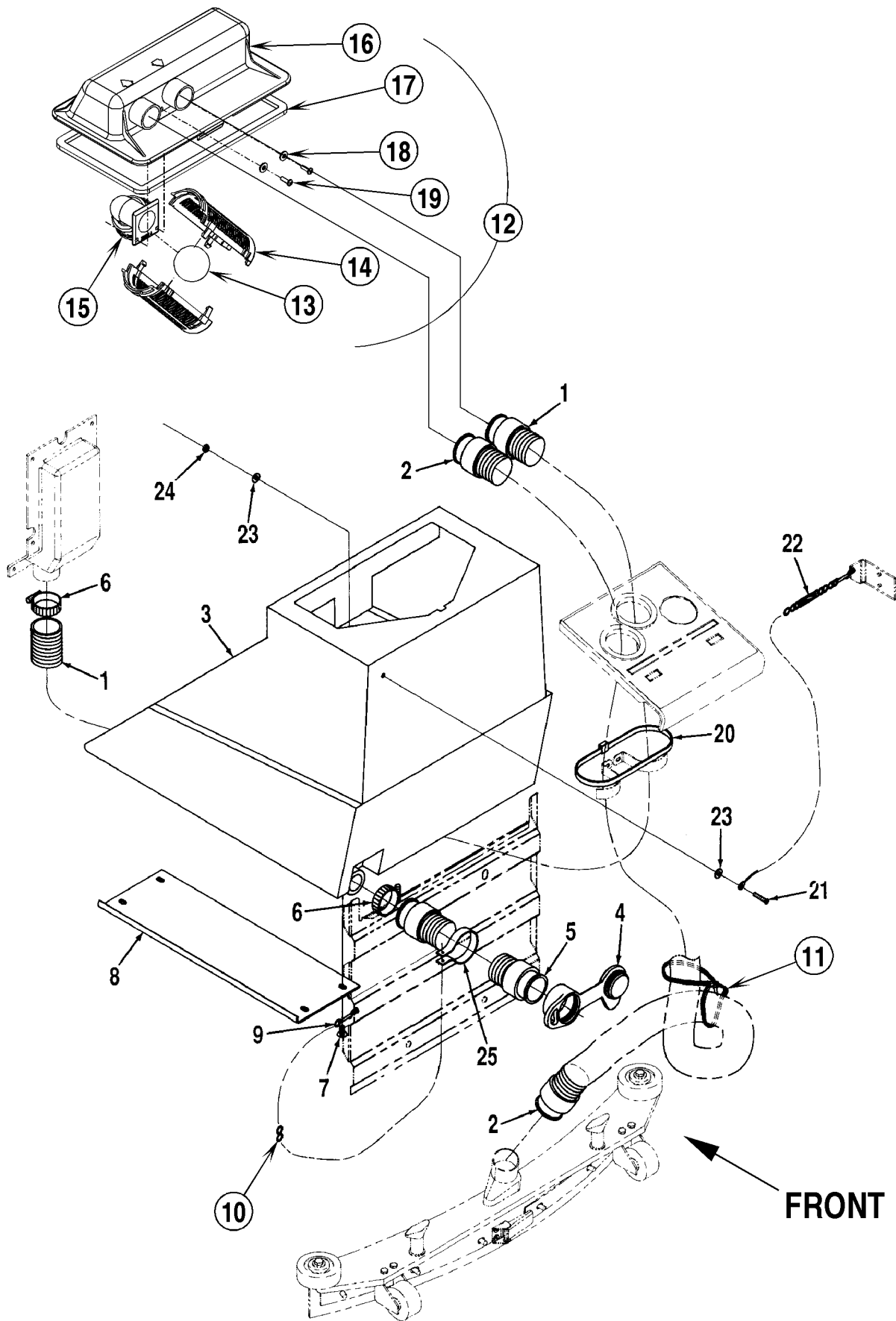

**RECOVERY TANK SYSTEM**

01-6

**Convertamatic™ 200E****19**

Item	Ref. No.	Qty	Description
1	56391753	1	Vacuum Hose (vac motor)
2	56324255	1	Vacuum Hose (squeegee)
3	56324179	1	Recovery Tank <b>Note #2</b>
4	56324180	1	Drain Plug
5	56372216	1	Drain Hose
6	56329145	2	Hose Clamp
7	56002924	4	1/4-20 x 1/2 Screw <b>Note #1</b>
8	56386055	1	Panel <b>Note #1 / Note #2</b>
9	56324281	1	Snap Swivel
	56324045	1	Cover Assembly (#10-19, 28)
10			<b>Intentionally Omitted</b>
11			<b>Intentionally Omitted</b>
12	56324045	1	Cover Assy ( <b>#13-19</b> )
13	56391690	1	Ball
14	56324497	2	Cage, Float
15	56324298	1	Elbow, Float
16	56324046	1	Cover, Tank
17	56262576	1	Gasket
18	56209261	2	Washer, Sealing 9/16
19	56003633	2	Scr, Pan Phil SS Type B 10-16 x .50
20	56477613	5	Cable Tie
21	56002098	1	#10-24 x 1 SS Screw <b>Note #1</b>
22	56324283	1	Cable <b>Note #1</b>
23	56002919	2	#10 SS Flat Washer <b>Note #1</b>
24	56002836	1	#10-24 SS Nyl Loc Nut <b>Note #1</b>
25	56263379	1	Cover Strap
26	56745391	1	"S" Hook
27	56393381	1	Wire Tie

**Note #1:** This part is only used on machines before SN 1005511.

**Note #2:** Panel PN 56386055 is no longer used to mount the recovery tank PN 56324179 to the chassis. New recovery tanks will not have the (4) inserts in the bottom to install the panel. The tank will be mounted simply by nesting into the chassis.

SQUEEGEE SYSTEM (BEFORE SN0536425)

20

Convertamatic™ 200E

01-6

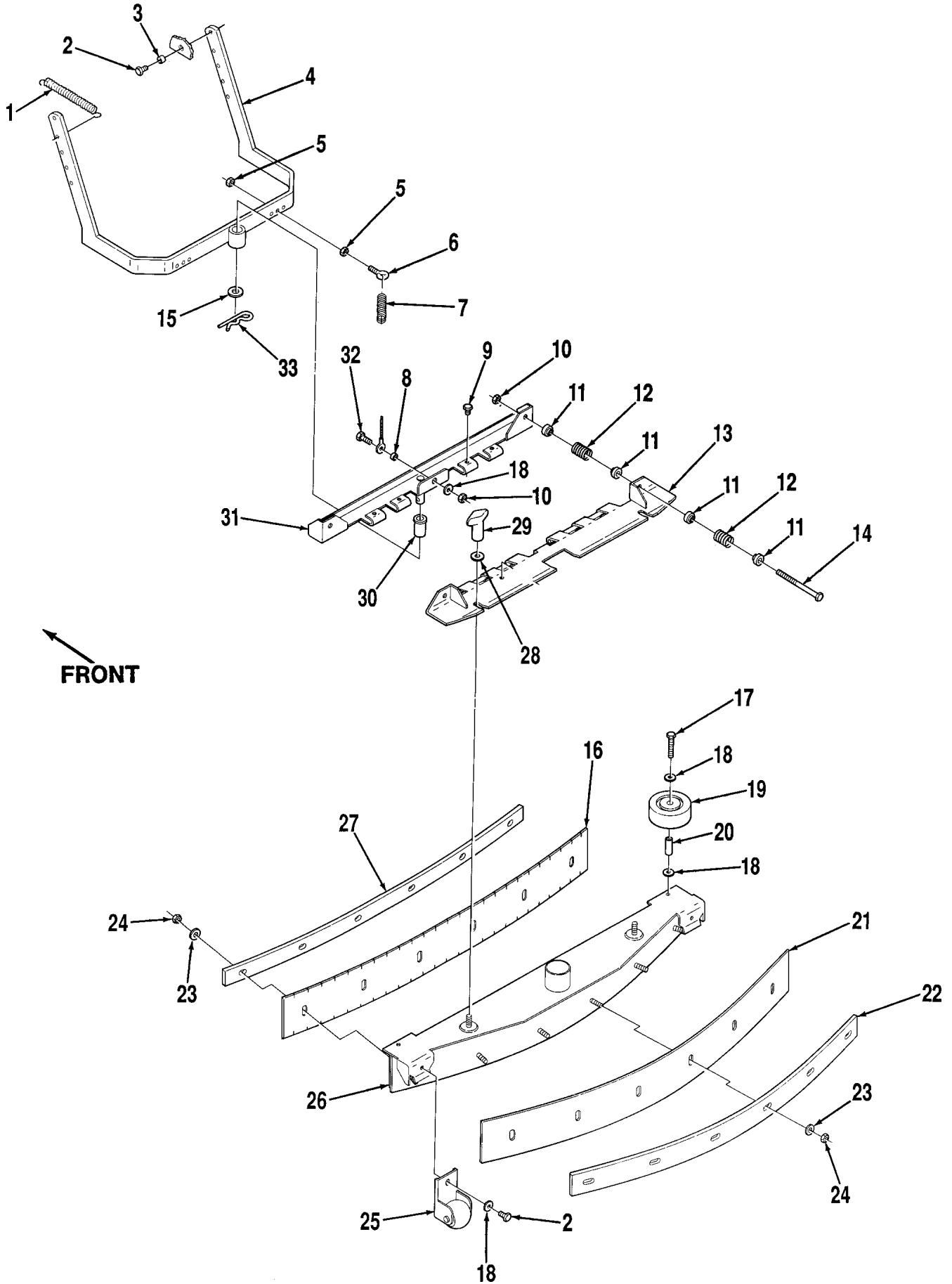

**SQUEEGEE SYSTEM (BEFORE SN0536425)**

01-6

**Convertamatic™ 200E**

**21**

Item	Ref. No.	Qty	Description
1	56448112	2	Spring
2	56002514	4	1/4-20 x 3/4 HP-5 Screw
3	56206784	2	Bushing
4	56324143	1	Linkage
5	56002832	4	#10-24 Nut
6	56388599	2	Eye Bolt
7	56470672	2	Spring
8	56163872	1	Bushing
9	56002486	4	#10-24 x 3/8 HP-5 Screw
10	56002708	3	1/4-20 Lock Nut
11	56384708	8	Step Bushing
12	56171177	4	Spring
13	56324152	1	Hinge Plate
14	56002689	2	1/4-20 x 3-1/2 Screw
15	56001953	1	7/16 Washer
	56324301	1	Squeegee Assembly (#16-29)
16	56324026	1	Front Blade
	56324254	1	Blade Kit, contains one each (#16, #21)
17	56002537	2	1/4-20 x 1-1/2 HP-5 Screw
18	56002098	7	1/4 Flat Washer
19	56363855	2	Wheel
20	56471220	2	Bushing
21	56324025	1	Rear Blade
	56324254	1	Blade Kit, contains one each (#16, #21)
22	56324147	1	Rear Strap
23	56002536	12	1/4 Brass Washer
24	56002850	12	1/4-20 Stainless Steel Nut
25	56387376	2	Roller
26	56324135	1	Squeegee Mount
27	56324148	1	Front Strap
28	56001939	2	5/16 Flat Washer
29	56370711	2	Thumb Nut
30	56492471	1	Bearing
31	56324140	1	Pivot Bracket
32	56002093	1	1/4-20 x 1 Screw
33	56321406	1	Pin

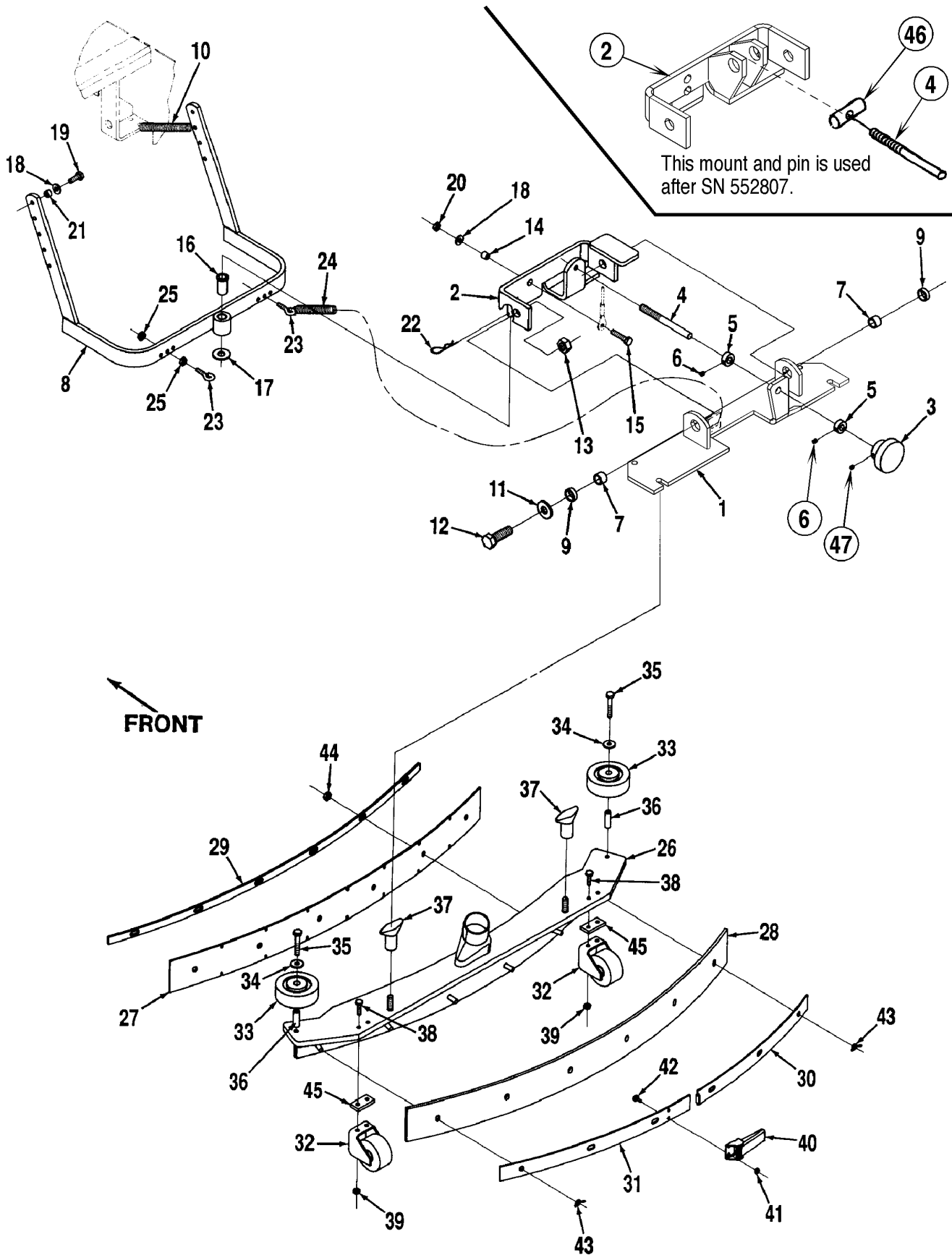

**SQUEEGEE SYSTEM (AFTER SN0536424)**

02-9

**Convertamatic™ 200E**

**23**

Item	Ref. No.	Qty	Description
1	56324330	1	Mount
2	56324404	1	Mount <b>Note #1 (before SN 0552807)</b>
	56324333	1	Mount <b>(after SN 0552806)</b>
3	56475480	1	Knob
4	56391855	1	Rod
5	56331076	2	Collar
6	56009084	2	Scr, Soc Set Loc 10-24 x .19
7	56360627	2	Bushing
8	56324143	1	Linkage
9	56478781	2	Bearing
10	56448112	2	Spring
11	56001879	2	1/2 Flat Washer
12	56001968	2	1/2-13 x 1-1/2 Bolt
13	56002770	2	1/2-13 Nyl Loc Nut
14	56324321	1	Bushing
15	56001821	1	1/4-20 x 7/8 Screw
16	56492471	1	Bearing
17	56001953	1	7/16 Flat Washer
18	56002098	3	1/4 Flat Washer
19	56002514	2	1/4-20 x 3/4 HP-5 Screw
20	56002708	1	1/4-20 Nyl Loc Nut
21	56206784	2	Bushing
22	56002959	1	Pin
23	56388599	2	Eye Bolt
24	56470672	2	Spring
25	56002832	4	#10-24 Nyl Loc-Thin Nut
26	56324403	1	Squeegee Tool
	56324397	1	Squeegee Tool Assy ( <b>#26-45</b> )
27	56324325	1	Front Blade (std. & oil res.)
28	56324322	1	Rear Blade (std.)
	56324383	1	Rear Blade (oil res.)
29	56324402	1	Front Strap
30	56324398	1	Right Rear Strap
31	56324399	1	Left Rear Strap
32	56391218	2	Roller
33	56393755	2	Wheel
34	56002859	2	1/4 SS Flat Washer
35	56002993	2	1/4-20 x 1-1/2 SS Screw
36	56471220	2	Bushing
37	56370711	2	Thumb Nut
38	56002837	4	1/4-20 x SS Screw
39	56002836	4	#10-24 SS Nyl Loc Nut
40	56471194	1	Latch
41	56002964	2	#6-32 SS Nyl Loc-Thin Nut
42	56002909	2	#6-32 x 3/8 SS Pan Hd Screw
43	56002963	2	1/4-20 SS Wing Nut
44	56002850	6	1/4-20 SS Nyl Loc-Thin Nut
45	56324351	2	Plate
46	56324369	1	Pin <b>Note #1</b>
47	56003123	1	Scr, Soc Set 10-24 x .38
	56324385	1	Standard Blade Kit
	56324384	1	Oil Resistant Blade Kit

**Note #1:** If you are replacing mount PN 56324404 with the redesigned mount PN 56324333 and you will also need item #46 pin, (part number 56324369).

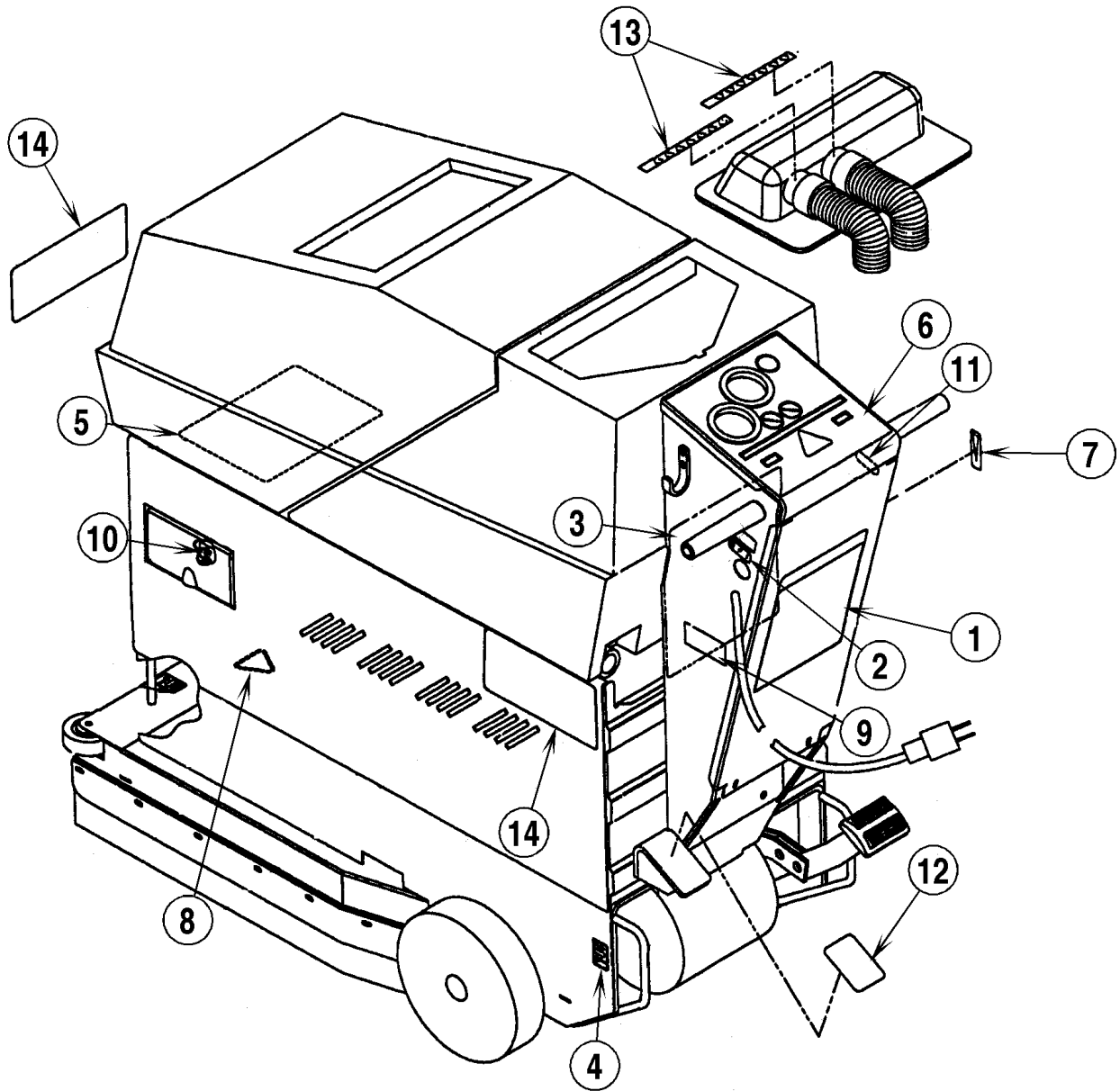

**DECAL SYSTEM**

02-9

**Convertamatic™ 200E****25**

Item	Ref. No.	Qty	Description
1	56014515	1	Decal, Caution
2	56015422	1	Decal, Power
3	56015388	1	Decal, Wiring (115V)
	56015420	1	Decal, Wiring (240V)
4	56015370	4	Decal, Tie Down
5	56014601	1	Decal, Caution
6	56015157	1	Decal, Control
7	56016334	1	Decal, Solution Valve
8	56015506	1	Decal, Rotating Brush
9	56016008	1	Decal, Wear Items
10	56015298	1	Decal, Reset (115V)
	56015527	1	Decal, Reset (240V)
11	56015487	1	Decal, On-Off-On
12	56324440	1	Pad, Grip
13	56015655	2	Decal, Direction
14	56015019	3	Decal, Convertamatic 200E

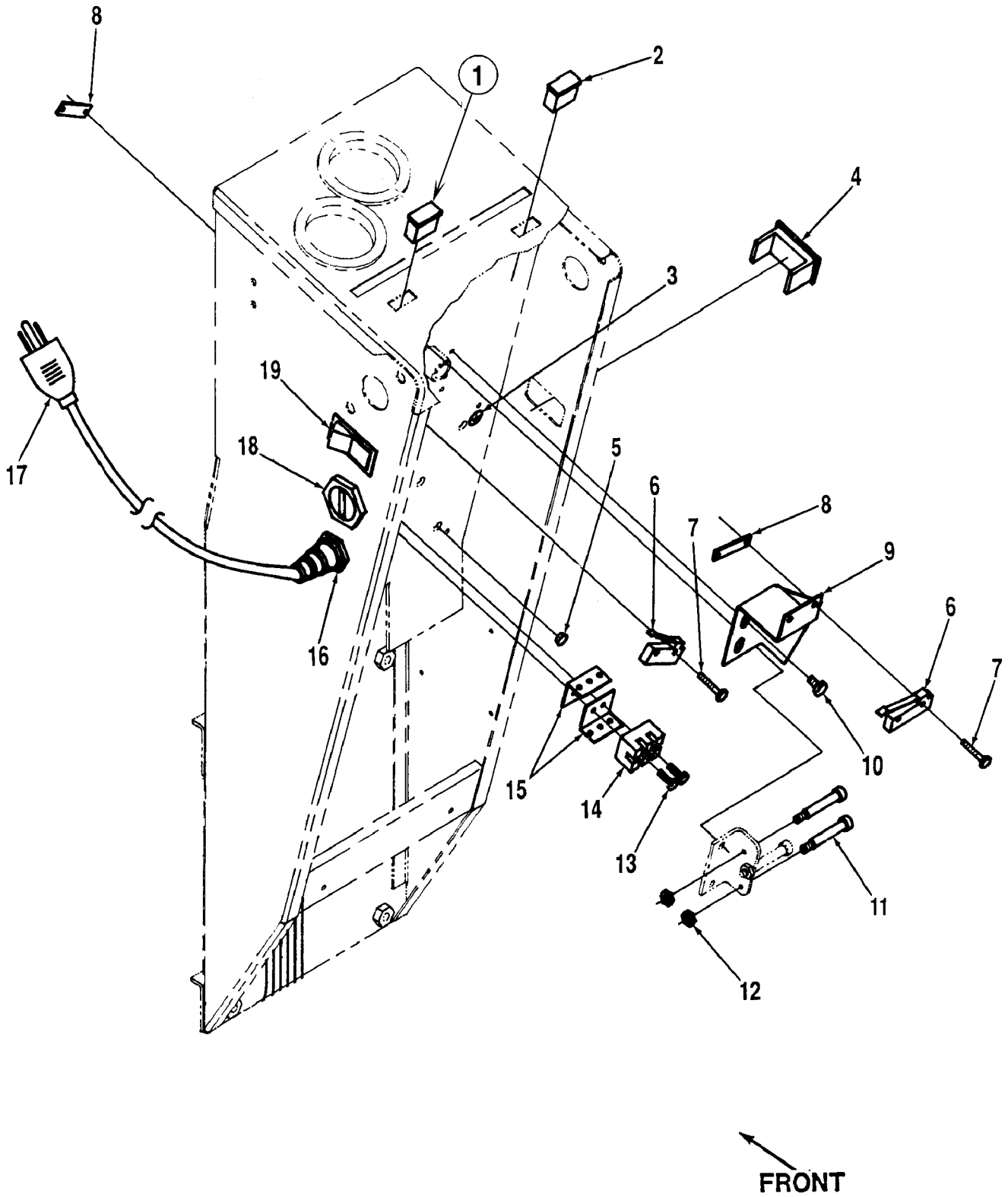

**HANDLE ELECTRICAL SYSTEM**

02-9

**Convertamatic™ 200E****27**

Item	Ref. No.	Qty	Description
1	56324274	1	Green Light 115V
	56324346	1	Green Light 240V
2	56324275	1	Blue Light 115V
	56324345	1	Blue Light 240V
3	56014119	1	Decal, Ground
4	56260155	1	Plug
5	56493149	2	Cap Plug
	56324364	7	Rubber Plug
6	56324362	2	Snap Switch
7	56003084	4	#6-32 x 1 Screw
8	56376015	2	Nut Plate
9	56324232	1	Switch Bracket
10	56002519	2	#10-24 x 3/8 HP-5 Screw
11	56900481	2	#10-24 x 1-1/4 Shoulder Screw
12	56002768	2	#10-24 Nyl Loc Nut
13	56002712	2	#4-40 x 5/8 HP-5 Screw
14	56183523	1	Terminal Block
15	56183533	2	Terminal Block Insulation 240V
16	56323136	1	Strain Relief
*	56171094	1	Lock Nut
17	56330871	1	Power Cord 115V
	56382331	1	Power Cord 240V
18	56393325	1	Keylock Bracket 115Vac & 240Vac
*	56301636	1	Toggle Switch
*	56393415	1	Replacement Key for Key Lock Bracket
19	56324272	1	Rocker Switch

\* = Not Shown

FRONT

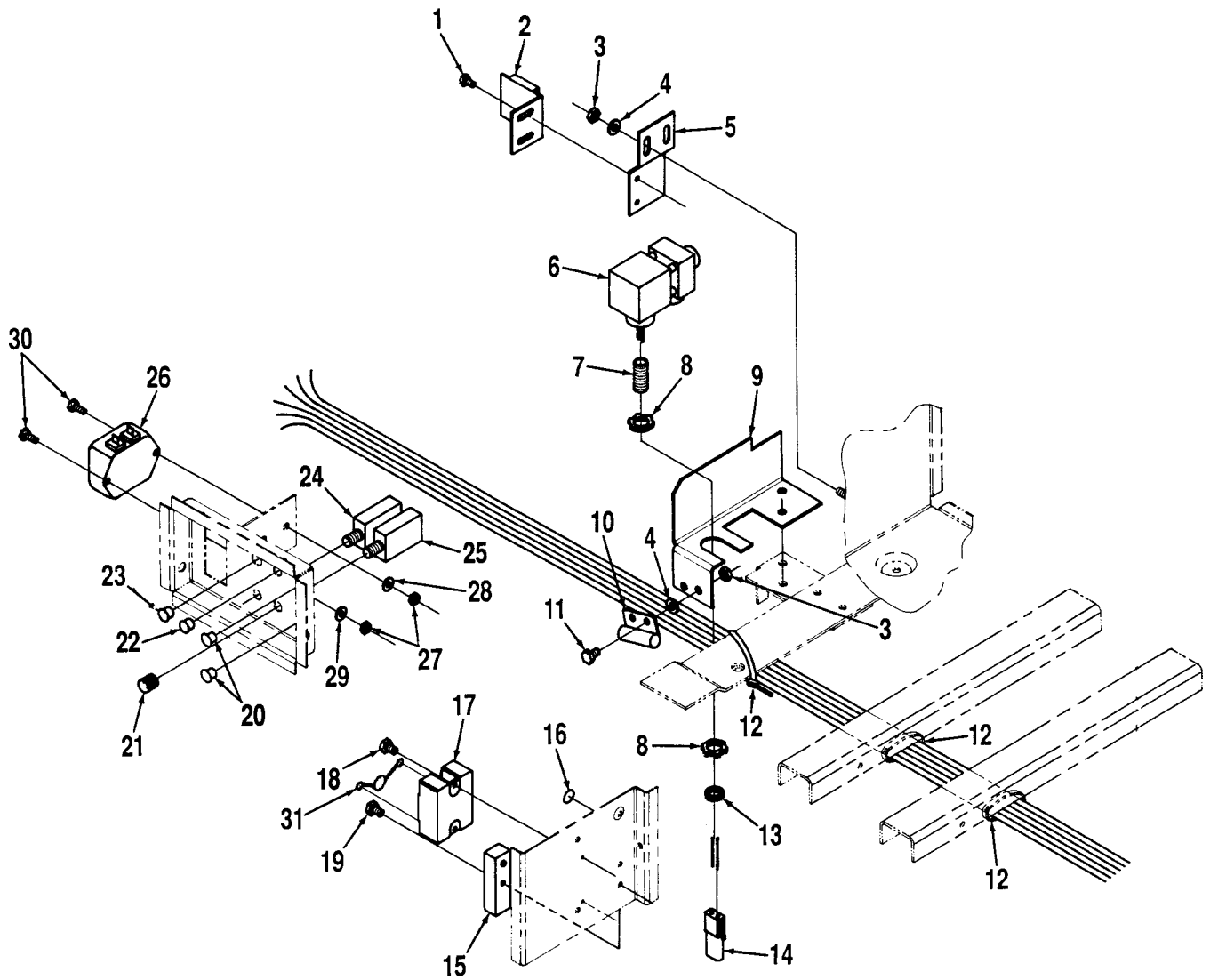

**CHASSIS ELECTRICAL SYSTEM**

01-6

**Convertamatic™ 200E****29**

Item	Ref. No.	Qty	Description
1	56002519	2	#10-24 x 3/8 HP-5 Screw
2	56324271	1	Waterproof Switch
3	56002708	4	1/4-20 Nyl Loc Nut
4	56002098	6	1/4 Flat Washer
5	56324062	1	Switch Plate
6	56324267	1	Solenoid Valve 115V
	56324342	1	Solenoid Valve 240V
7	56324250	1	Conduit
8	56171094	3	Lock Nut
9	56324239	1	Solenoid Bracket
10	56324278	1	Mercury Switch
11	56001861	2	1/4-20 x 3/8 Screw
12	56477613	3	Cable Tie
13	56324251	1	Insulating Bushing
14	56393149	1	Plug
15	56260071	1	Terminal Block
16	56014119	1	Decal, Ground
17	56324334	1	Relay <b>Note #1</b>
18	56001904	2	#6-32 x 3/8 HP-5 Screw
19	56002423	1	#8-32 x 1/2 HP-5 Screw
20	56153699	2	Cap Plug
21	56459367	2	Reset Button Boot
22	56493149	1	Cap Plug
23	56323560	1	Cap Plug
24	56329177	1	6A Circuit Breaker 115V
	56329117	1	6A Circuit Breaker 240V
25	56454538	1	15A Circuit Breaker 115V
	56168444	1	8A Circuit Breaker 240V
26	56650312	1	RFI Filter 240V
27	56002768	2	#10-24 Nyl Loc Nut 240V
28	56001954	1	#10 Flat Washer 240V
29	56002011	1	#10 Shakeproof Washer 240V
30	56002503	2	#10-24 x 1/2 Screw
31	56250168	1	Varistor 115V, 240V <b>Note #1</b>

**Note #1:** This part is installed on all machines after SN 0608030. If your machine does not have this varistor , install it. Varistor PN 56250168 should be connected between the (2) terminals (of relay item #17) with the black and white wires connected to them on both the 115V and the 240V models.



**WIRING DIAGRAM - 115V**

01-6

**Convertamatic™ 200E****31**

Ref. No.	Qty	Description
56324275	1	Blue Light
56324362	1	Brush Initiate Switch
56324271	1	Brush Lock Switch
56385630	1	Brush Motor
56329177	1	Circuit Breaker 6A
56454538	1	Circuit Breaker 15A
56324274	1	Green Light
56301636	1	Main Switch
56324278	1	Mercury Switch
56330871	1	Power Cord
56324334	1	Relay <b>Note #1</b>
56324267	1	Solenoid Valve
56324272	1	Solution Switch
56183523	1	Terminal Block X1
56260071	1	Terminal Block X2
56324263	1	Vacuum Motor
56324362	1	Vacuum Motor Switch
56250168	1	Varistor <b>Note #1</b>

**Note #1:** This part is installed on all machines after SN 0608030. If your machine does not have this varistor , install it. Varistor PN 56250168 should be connected between the (2) terminals (of relay item #17) with the black and white wires connected to them on both the 115V and the 240V models.

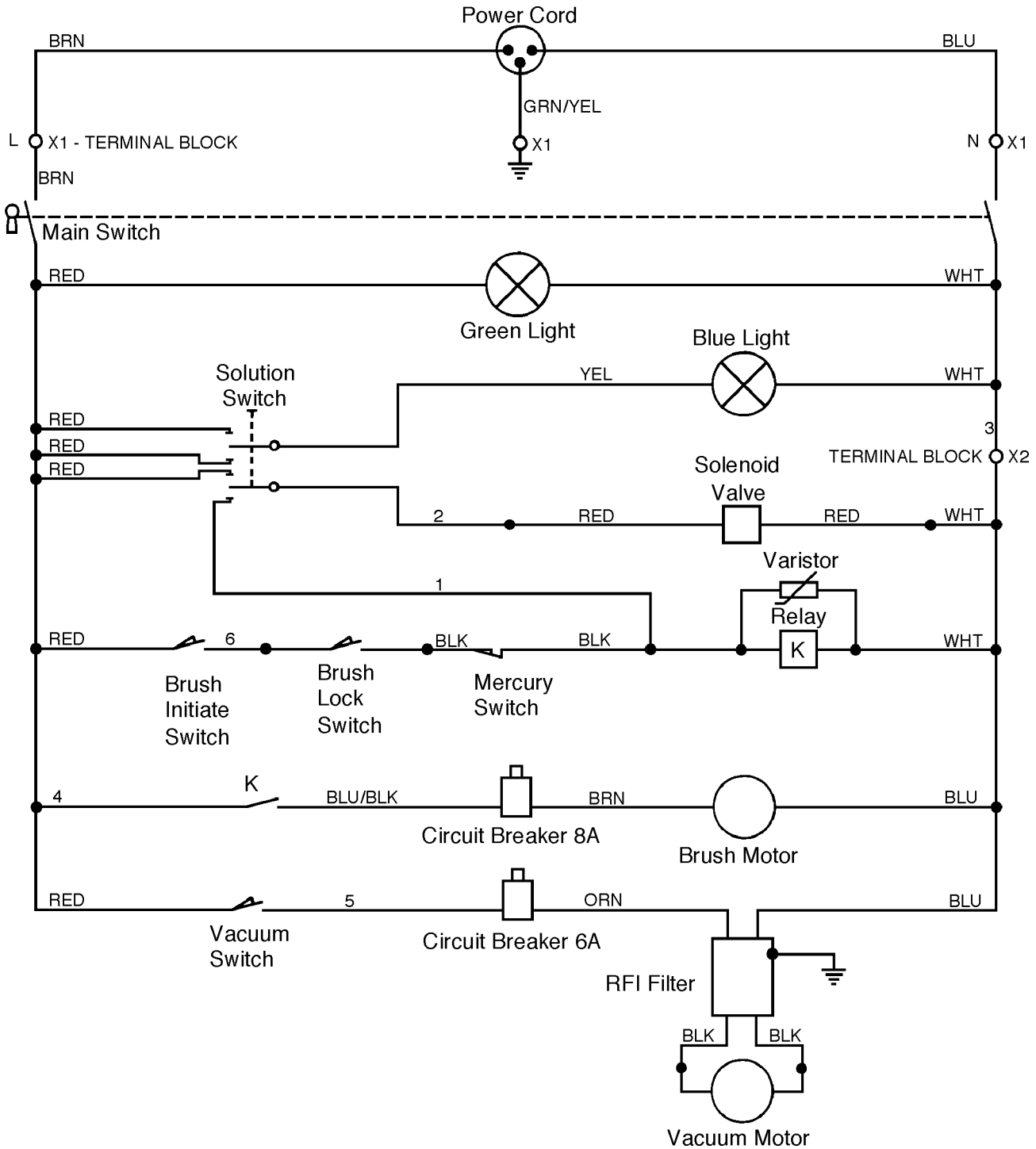

**WIRING DIAGRAM - 220-240V**

01-6

**Convertamatic™ 200E****33**

Ref. No.	Qty	Description
56324345	1	Blue Light
56324362	1	Brush Initiate Switch
56324271	1	Brush Lock Switch
56387009	1	Brush Motor
56329177	1	Circuit Breaker 6A
56168444	1	Circuit Breaker 8A
56324346	1	Green Light
56301636	1	Main Switch
56324278	1	Mercury Switch
56382331	1	Power Cord
56324334	1	Relay <b>Note #1</b>
56324365	1	RFI Filter
56324342	1	Solenoid Valve
56324272	1	Solution Switch
56183523	1	Terminal Block X1
56260071	1	Terminal Block X2
56324344	1	Vacuum Motor
56324362	1	Vacuum Motor Switch
56250168	1	Varistor <b>Note #1</b>

**Note #1:** This part is installed on all machines after SN 0608030. If your machine does not have this varistor , install it. Varistor PN 56250168 should be connected between the (2) terminals (of relay item #17) with the black and white wires connected to them on both the 115V and the 240V models.



Nilfisk-Advance, Inc.  
14600 21st Avenue North  
Plymouth, MN, 55447-3408  
[www.nilfisk-advance.com](http://www.nilfisk-advance.com)  
Phone: 800-989-2235  
Fax: 800-989-6566  
©2002 Nilfisk-Advance, Inc.,  
Plymouth, MN 55447-3408  
Printed in the U.S.A.