

MAXXI 75 ALTO

Model:
MAXXI II - 75 -
Nilfisk-ALTO

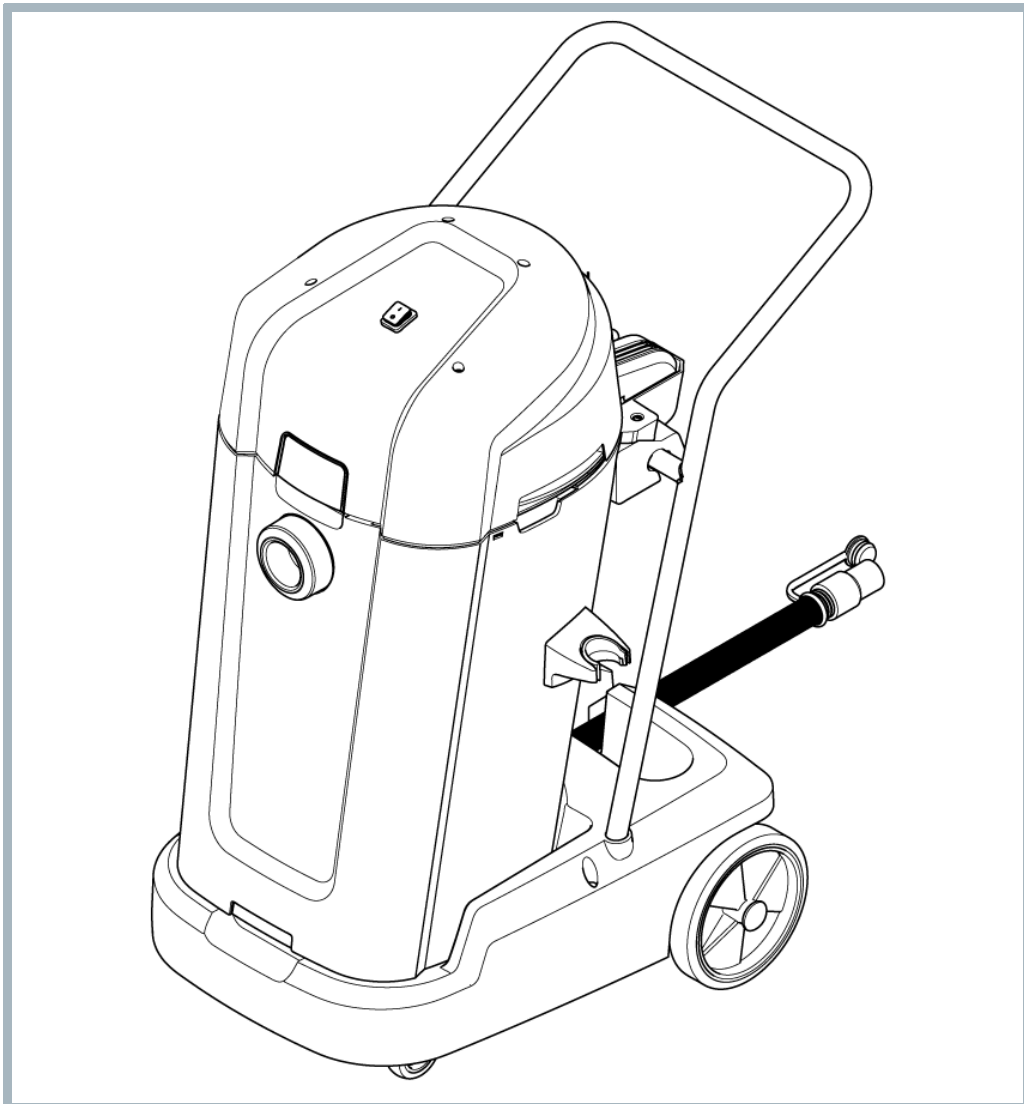

Part List US-English

05-09-2013

Nilfisk
ALTO
works for you

www.nilfisk-alto.com

Table of Contents

MAXXI 75 ALTO

Top 55-1, 75-1	3
Top 55-2, 75-2	5
Container 75 BSF, BDF	7
Filter and bags 55, 75	9
Squeegee Accessory	11
Accessories	13
Recommended Spare Parts	15

Top 55-1, 75-1

MAXXI 75 ALTO

05-09-2013

Part List ID
MAXXIII04

3

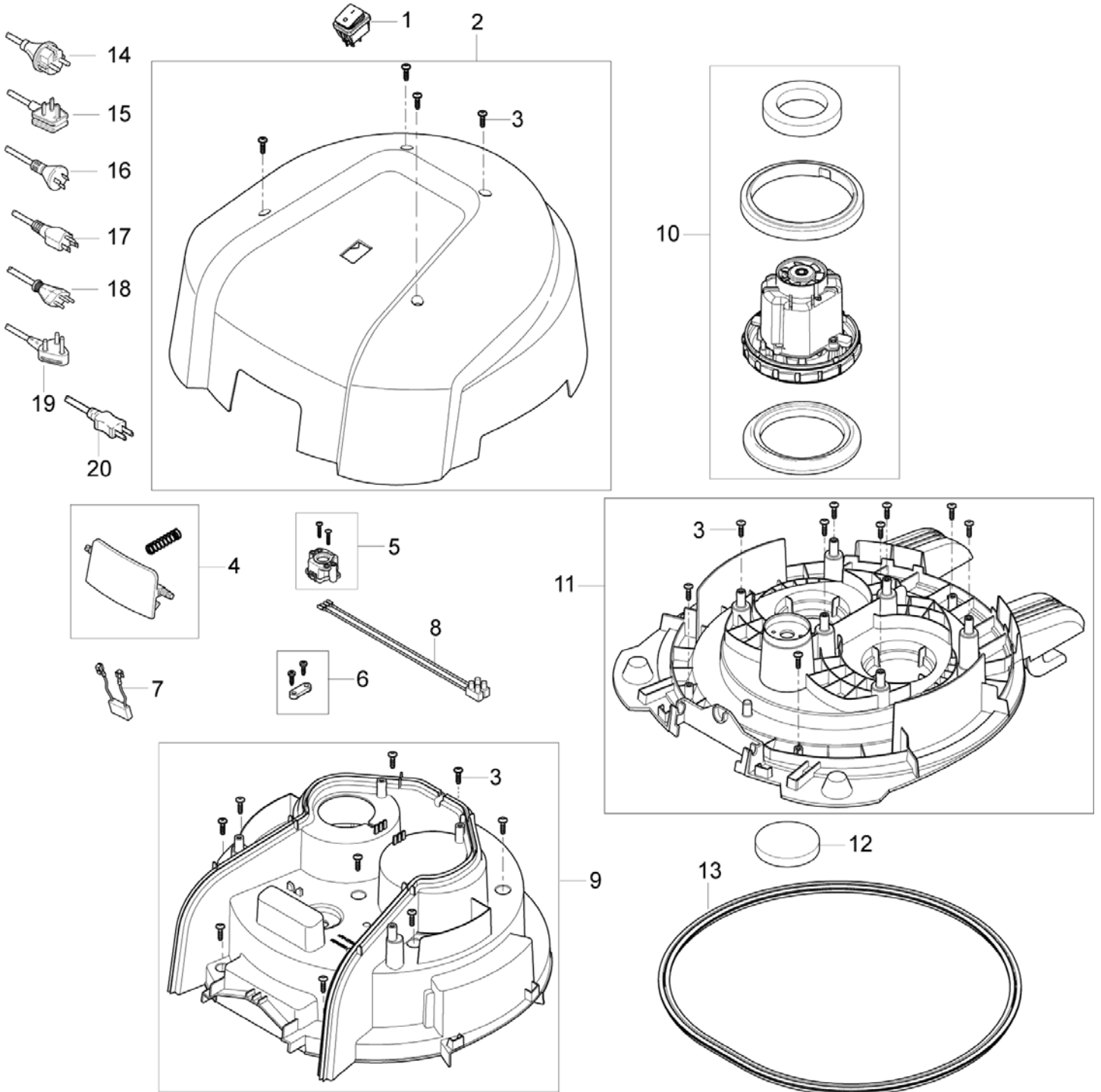

Top 55-1, 75-1

MAXXI 75 ALTO

05-09-2013

Part List ID
MAXXIII04

4

Pos	Part no.	Qty	Description
01	140 9537 500	1	SWITCH TWO POLE KIT
02	107407244	1	HOOD 75-55L 1 SWITCH MAXXI
03	302003704	13	SCREW EJOT DELTA PT50X18WN5451
04	107407236	1	CLAMP F. 75-55-35 L BIN MAXXI
05	107407237	1	VACUUM VALVE CPL.
06	140 6560 500	1	ANTI STRAIN CLIP
07	48338	1	ANTI-INTERFERENCE CAPACITOR
08	140 7042 500	1	WIRE INTERNAL FOR GWD 300
09	107407246	1	CLAMPING PLATE 55-75-1 VMAXXI
10	302003384	1	MOTOR KIT 1200W 230V
10	302003388	1	MOTOR KIT 1000W 120V
11	107407248	1	BASEPLATE 75-55L 1 MOTOR MAXXI
12	140 8682 500	1	MOTOR FILTER
13	107407249	1	GASKET F. BASEPLATE 75-55L
14	12222501	1	CORD SET EU L 10M
15	140 8262 020	1	CORD SET BLACK 10.5M UK-PLUG
16	140 8262 010	1	CORD SET 10.5 M AU PLUG
17	107401614	1	CORD SET US/TW 3C 15.5M YELLOW
18	12222507	1	CORD SET CH L 10M
19	107407242	1	POWER CORD H05VV-F 2X1.00 SABS 164-1 16A
20	140 6702 500	1	CORD SET JP 15.5M

Top 55-2, 75-2

MAXXI 75 ALTO

05-09-2013

Part List ID
MAXXIII06

5

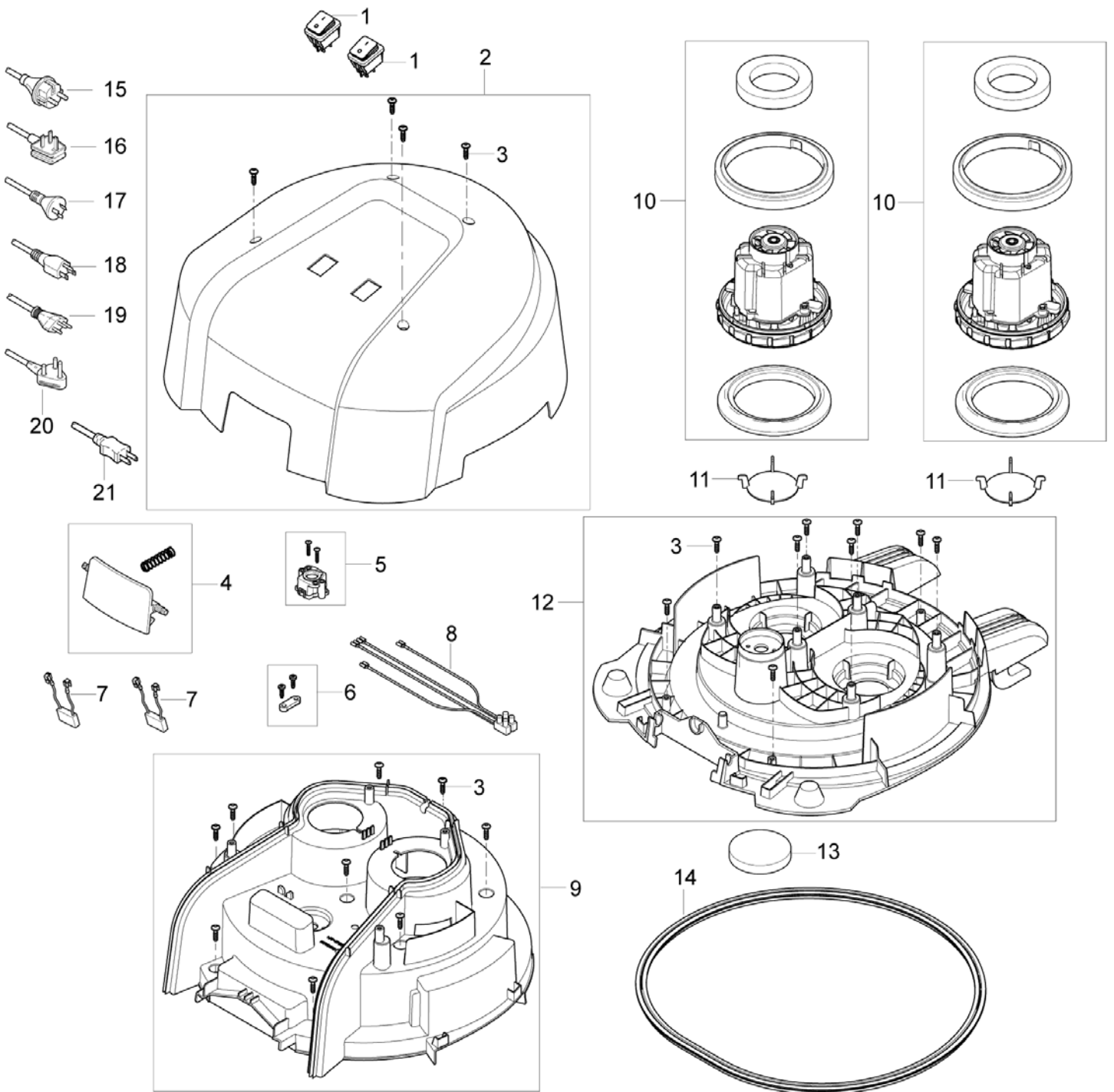

Top 55-2, 75-2

MAXXI 75 ALTO

05-09-2013

Part List ID
MAXXIII06

6

Pos	Part no.	Qty	Description
01	107404540	2	SWITCH 0-1 DOUBLE POLE SET
02	107407251	1	HOOD 75-55 L 2 SWITCHES MAXXI
03	302003704	13	SCREW EJOT DELTA PT50X18WN5451
04	107407236	1	CLAMP F. 75-55-35 L BIN MAXXI
05	107407237	1	VACUUM VALVE CPL.
06	140 6560 500	1	ANTI STRAIN CLIP
07	48338	1	ANTI-INTERFERENCE CAPACITOR
08	140 7620 530	1	SUPPRESSOR EU/UK/AU/NZ
09	107407253	1	CLAMPING PLATE 55-75-2 MAXXI
10	302003384	1	MOTOR KIT 1200W 230V
11	140 9526 500	1	VALVE DISC GWD 350/375
12	107407255	1	BASEPLATE 75-55L 2 MOTOR MAXXI
13	140 8682 500	1	MOTOR FILTER
14	107407249	1	GASKET F. BASEPLATE 75-55L
15	12222501	1	CORD SET EU L 10M
17	140 8262 010	1	CORD SET 10.5 M AU PLUG
18	107401614	1	CORD SET US/TW 3C 15.5M YELLOW
19	12222507	1	CORD SET CH L 10M
20	107407242	1	POWER CORD H05VV-F 2X1.00 SABS 164-1 16A
21	140 6702 500	1	CORD SET JP 15.5M

Container 75 BSF, BDF

MAXXI75 ALTO

05-09-2013

Part List ID
MAXXIII12

7

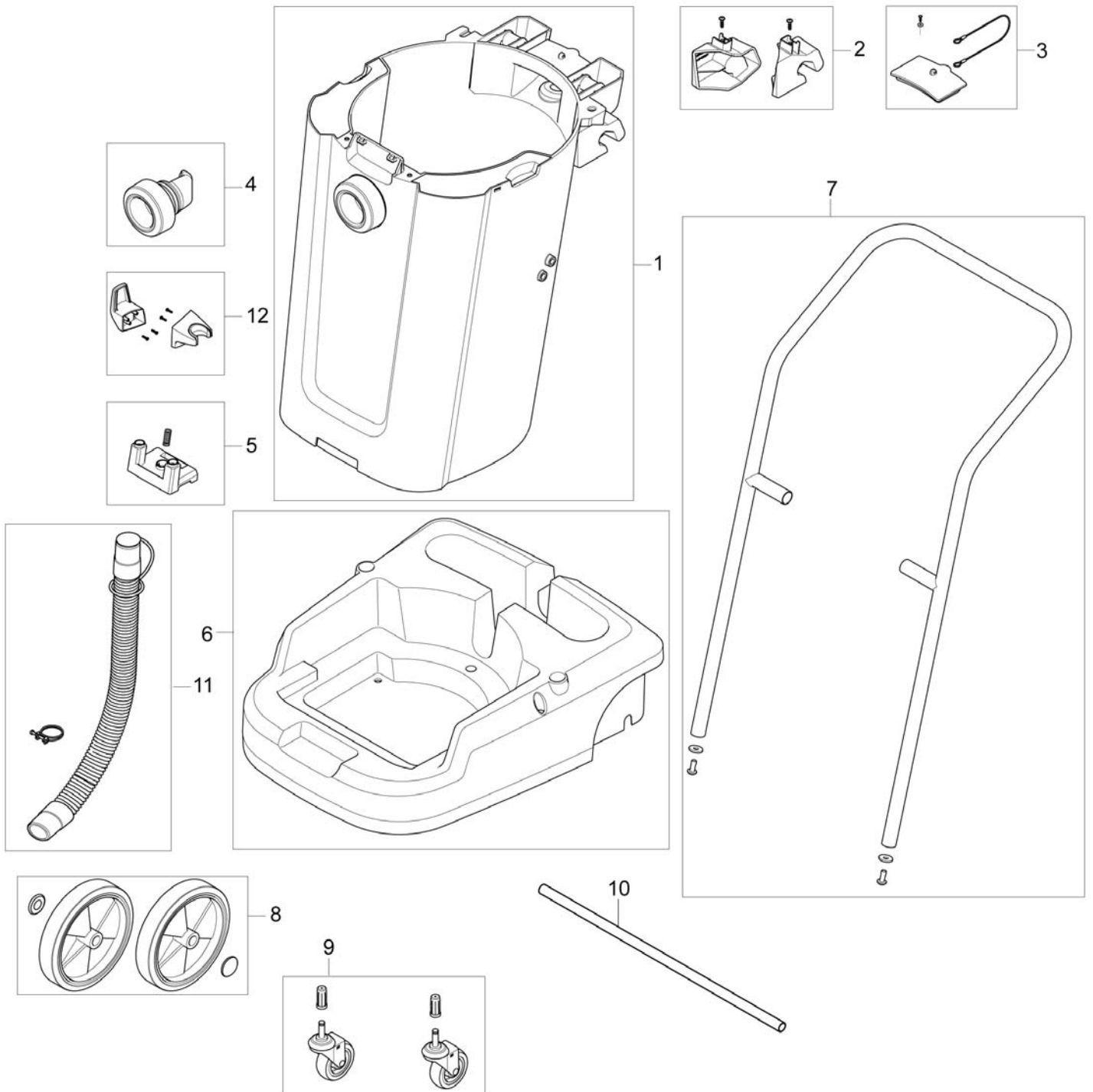

Container 75 BSF, BDF

MAXXI 75 ALTO

05-09-2013

Part List ID
MAXXIII12

8

Pos	Part no.	Qty	Description
01	107407275	1	CONTAINER 75L MAXXI
02	107407278	1	BRACKET LEFT-RIGHT F. 75L
03	107407266	1	SPOUT CAP
04	107407259	1	INLET ROUND MAXXI
05	107407281	1	PUSH-BUTTON F. EASY-TILT 75L MAXXI
06	107407270	1	FRAME F. BASIC TROLLEY MAXXI
07	107407282	1	HANDLE F. BASIC TROLLEY 75L
08	140 9543 500	1	REAR WHEEL
09	140 5476 500	1	WHEEL LINK TROLLEY 2-P
10	107407272	1	WHEEL 200MM WITH AXLE
11	107407307	1	DRAINHOSE F. 75L BIN
12	107408912	1	CABLE HOOK AND TUBE HOLDER MAXXI

Filter and bags 55, 75

MAXXI 75 ALTO

05-09-2013

Part List ID
MAXXIII24

9

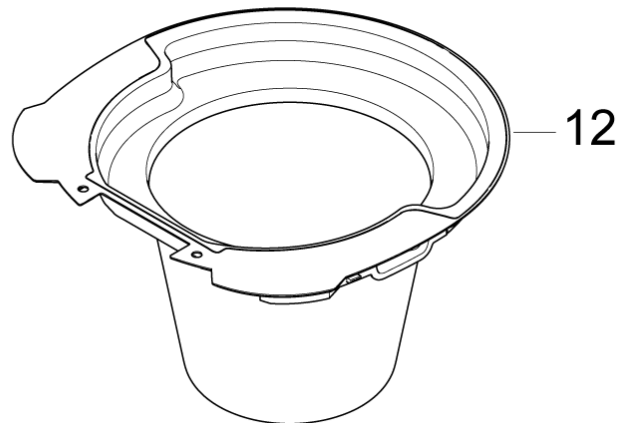
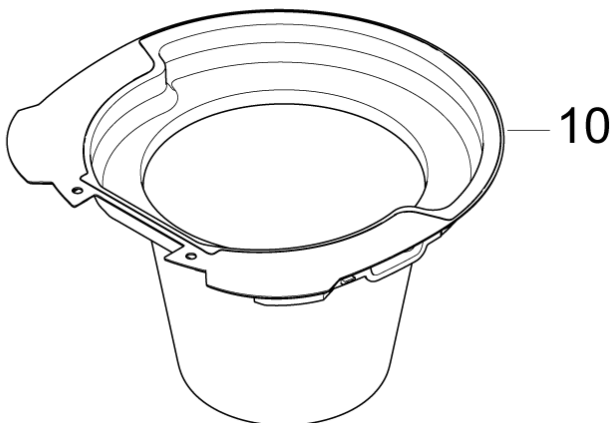
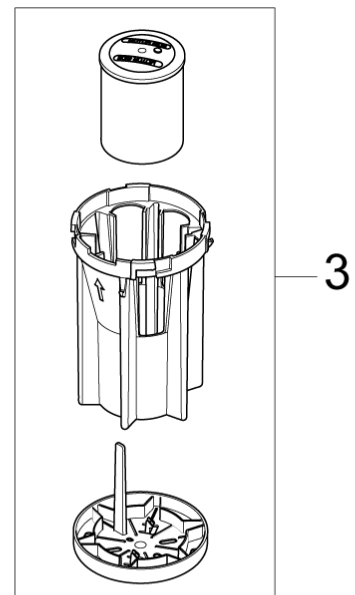
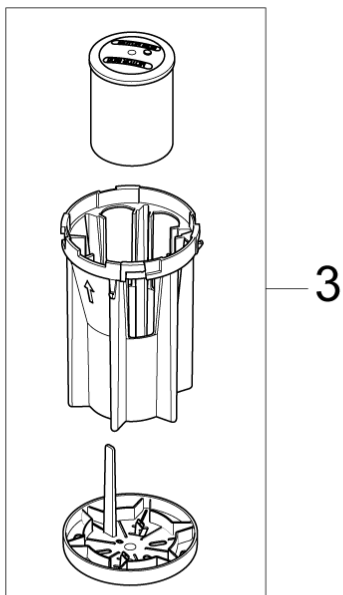
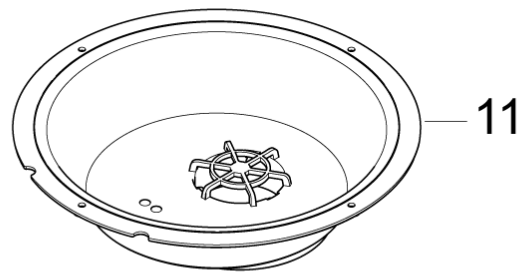
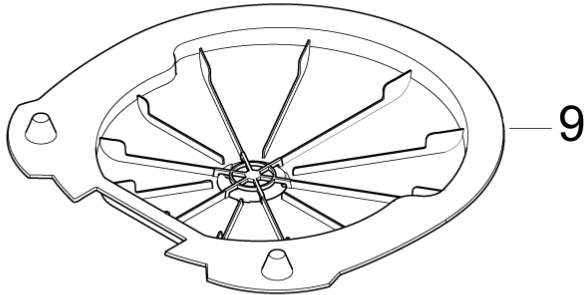
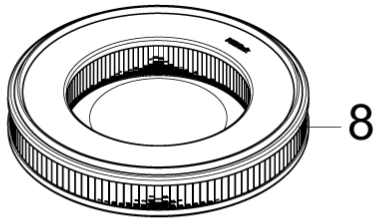

Filter and bags 55, 75

MAXXI 75 ALTO

05-09-2013

Part List ID
MAXXIII24

10

Pos	Part no.	Qty	Description	
02	140 8682 500	1	MOTOR FILTER	
03	140 8680 500	1	FLOAT BASKET	
08	107407300	1	CARTRIGE FILTER 75L	BDF, EDF
09	107407301	1	DRYFILTER BOX	BDF, EDF
10	107407302	1	WETFILTER 75-55L	BDF, EDF
11	107407303	1	FLOATER ADAPTER 55-75L	BSF
12	107407304	1	SACK FILTER 55-75L	BSF

Squeegee Accessory

MAXXI 75 ALTO

05-09-2013

Part List ID
MAXXI11024

11

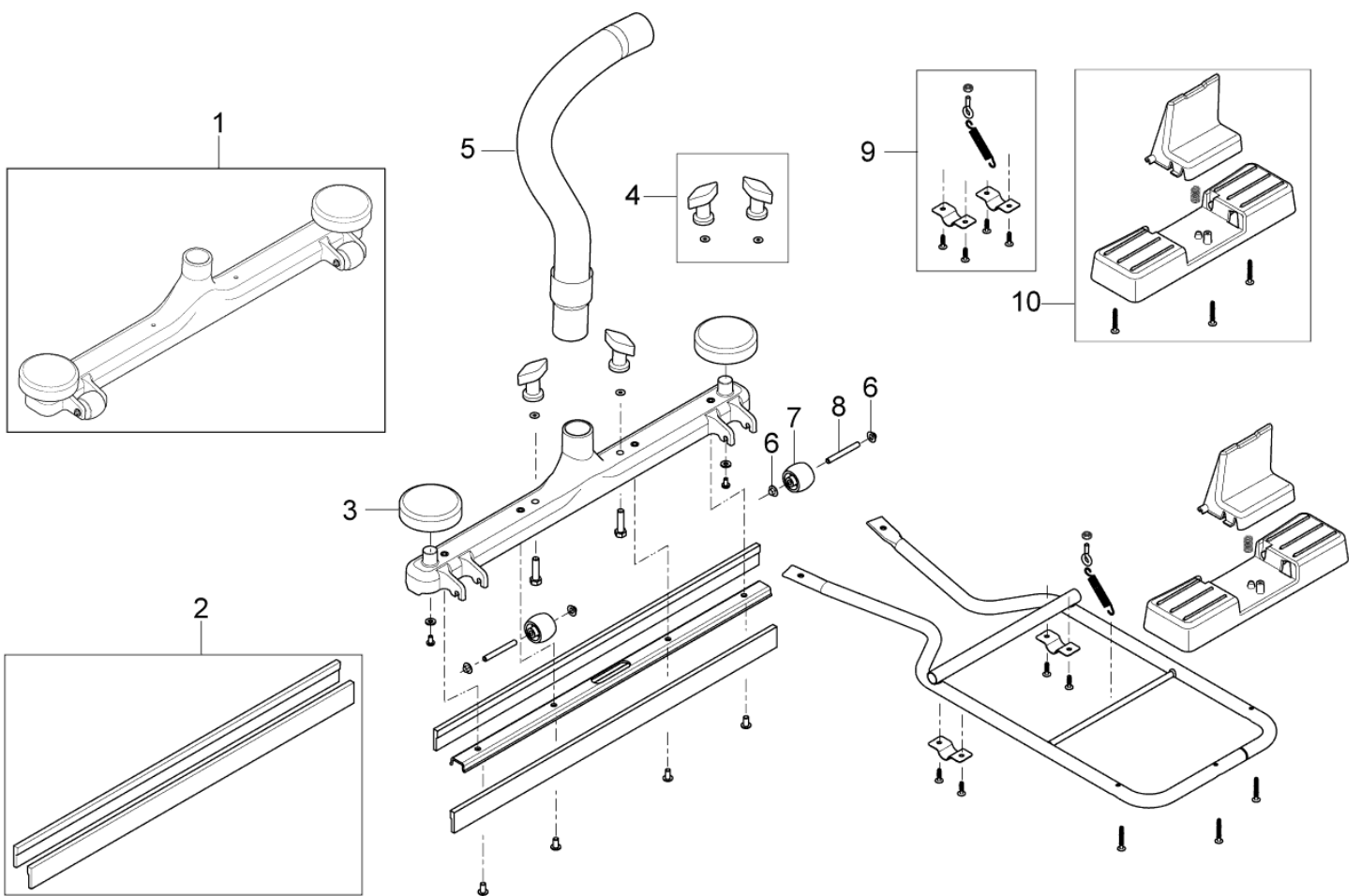

Squeegee Accessory

MAXXI 75 ALTO

05-09-2013

Part List ID
MAXXIIIQ24

12

Pos	Part no.	Qty	Description
0	107407050	1	SQUEEGEE COMPLETE JETBLACK
01	56209088	1	SQUEEGEE ASSEMBLY 24
02	56105533	1	BLADE BLUE FOR 24 E00601
03	56209157	2	BUMPER SIDE ROLLER
04	140 7947 500	1	NUT THUMB 5/16
05	107408917	1	HOSE FOR SQUEEGEE
06	56009132	4	NUT PUSH CAP 1/4
07	56329554	2	ROLLER
08	56209150	2	AXLE ROLLER
09	107408918	1	MOUNTING KIT FOR SQUEEGEE
10	107408915	1	PEDAL FOR SQUEEGEE BLACK

Accessories

MAXXI 75 ALTO

05-09-2013

Part List ID
VL500ADV12

13

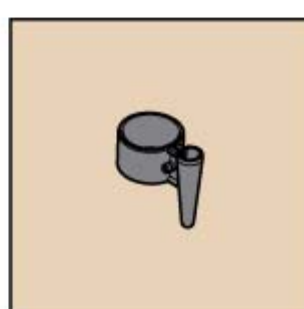
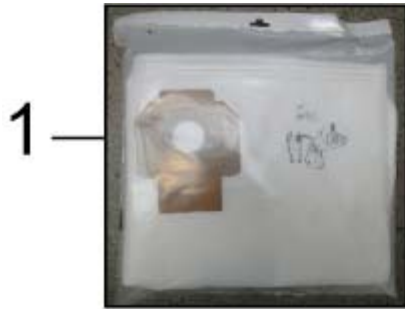

Accessories

MAXXI 75 ALTO

05-09-2013

Part List ID
VL500ADV12

14

Pos	Part no.	Qty	Description
1	302004000	1	FLEECE FILTER BAG 5 PCS ATTIX 30
1	302004004	1	FLEECE FILTER BAG 5 PCS ATTIX 40/50
2	107407308	1	HOSE D32 1.9M CPL
2	107407336	1	HOSE D40 2.5M CPL
3	107407310	1	FLOOR NOZZLE D32 RUBBER STRIP
3	107407311	1	FLOOR NOZZLE D32 BRUSH
3	107407338	1	FLOOR NOZZLE D40 RUBBER STRIP
4	107407309	1	EXTENSION TUBE D32 - SS
4	107407337	1	EXTENSION TUBE D40 - SS
5	107407334	1	CREVICE NOZZLE D32
5	107408850	1	CREVICE NOZZLE D40
6	107407312	1	BRUSH NOZZLE D32
6	107407339	1	FLOOR NOZZLE D40 BRUSH
8	107407335	1	TUBEHOLDER D40

Recommended Spare Parts

MAXXI75 ALTO

05-09-2013

Part List ID
MAXXIII220

15

No Drawing For Part List

Recommended Spare Parts

MAXXI 75 ALTO

05-09-2013

Part List ID
MAXXIII220

16

Pos	Part no.	Qty	Description
	107404540	1	SWITCH 0-1 DOUBLE POLE SET
	107407236	1	CLAMP F. 75-55-35 L BIN MAXXI
	107407237	1	VACUUM VALVE CPL.
	107407249	1	GASKET F. BASEPLATE 75-55L
	107407259	1	INLET ROUND MAXXI
	107407266	1	SPOUT CAP
	107407278	1	BRACKET LEFT-RIGHT F. 75L
	107407281	1	PUSH-BUTTON F. EASY-TILT 75L MAXXI
	107407300	1	CARTRIGE FILTER 75L
	107407301	1	DRYFILTER BOX
	107407302	1	WETFILTER 75-55L
	107407303	1	FLOATER ADAPTER 55-75L
	107407304	1	SACK FILTER 55-75L
	107407307	1	DRAINHOSE F. 75L BIN
	12222501	1	CORD SET EU L 10M
	140 5476 500	1	WHEEL LINK TROLLEY 2-P
	140 8446 500	1	REAR WHEEL KIT
	140 8680 500	1	FLOAT BASKET
	140 8682 500	1	MOTOR FILTER
	140 9526 500	1	VALVE DISC GWD 350/375
	140 9537 500	1	SWITCH TWO POLE KIT
	302003384	1	MOTOR KIT 1200W 230V
	302003388	1	MOTOR KIT 1000W 120V
	48338	1	ANTI-INTERFERENCE CAPACITOR