

MAXXI 35 ALTO

Model:
MAXXI II - 35 -
Nilfisk-ALTO

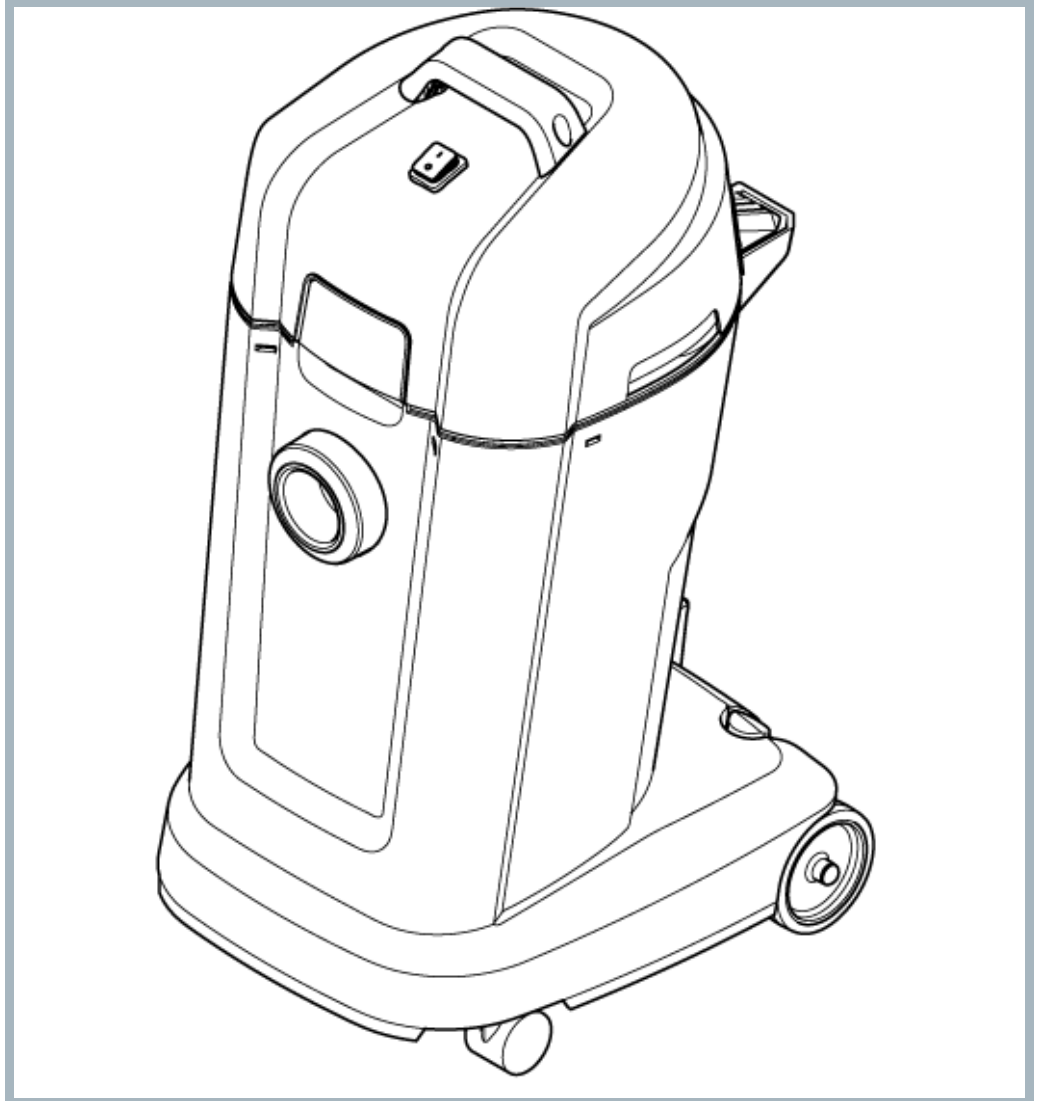

Part List English

22-07-2013

Nilfisk
ALTO
works for you

www.nilfisk-alto.com

Table of Contents

MAXXI 35 ALTO

Top 35	3
Container 35 BSF, BDF, EDF	5
Filters and bags 35	7
Accessories	9
Recommended Spare Parts	11

Top 35

MAXXI35 ALTO

22-07-2013

Part List ID
MAXXIII02

3

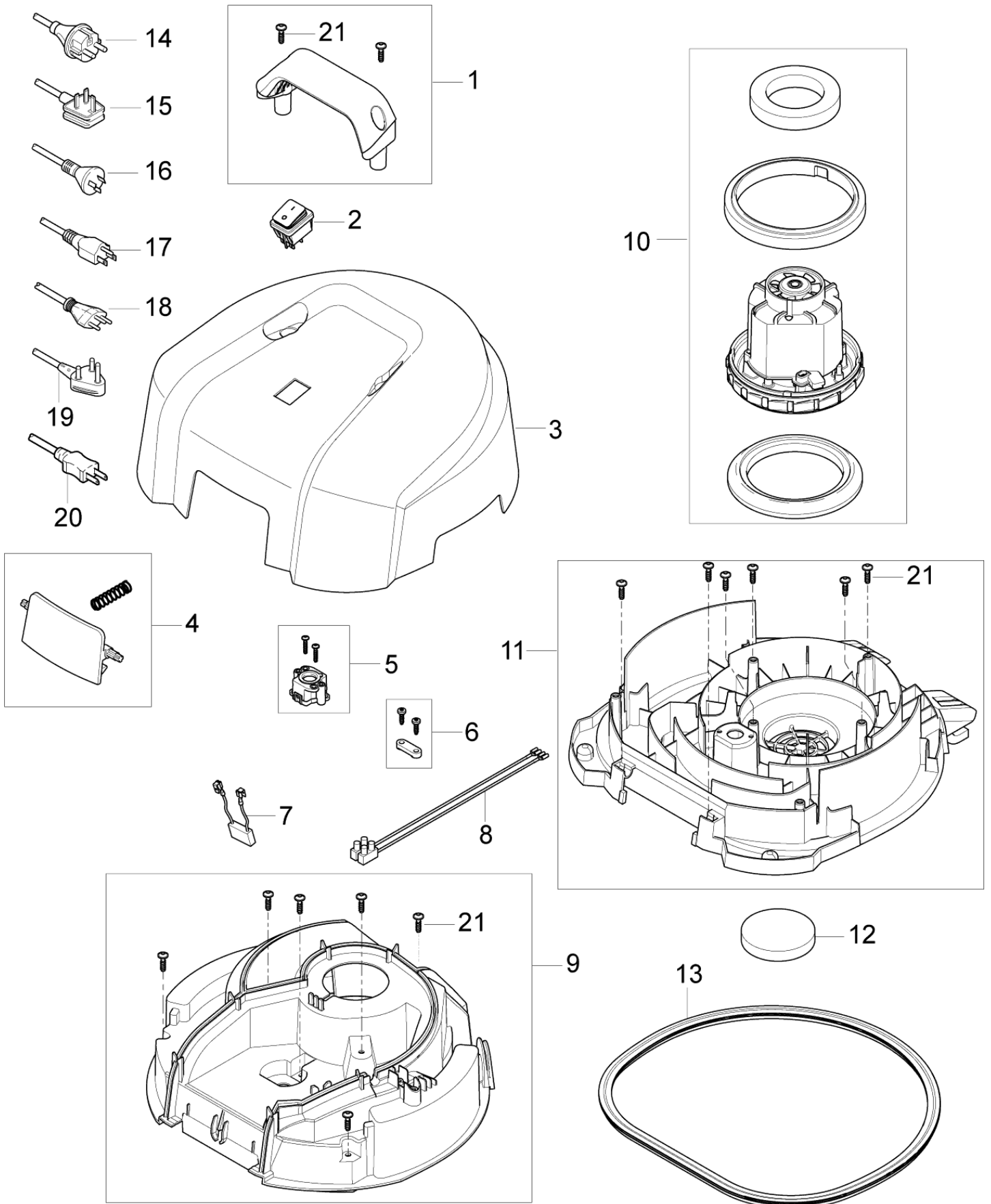

Top 35

MAXXI 35 ALTO

22-07-2013

Part List ID
MAXXIII02

4

Pos	Part no.	Qty	Description	
01	107407234	1	HANDLE F. 35L BIN MAXXI	
02	107404540	1	SWITCH 0-1 DOUBLE POLE SET	
03	107407306	1	HOOD 35L MAXXI	
04	107407236	1	CLAMP F. 75-55-35 L BIN MAXXI	
05	107407237	1	VACUUM VALVE CPL.	
06	140 6560 500	1	ANTI STRAIN CLIP	
07	48338	1	FILTER was 47326	
08	140 7042 500	1	WIRE, INTERNAL FOR GWD 300	
09	107407238	1	CLAMPINGPLATE 35L	
10	302003384	1	Turbine kit, 1200W 230V	
10	302003388	1	TURBINE KIT 1000w 120v	
11	107407240	1	BASEPLATE 35L 1 MOTOR MAXXI	
12	140 8682 500	1	MOTOR FILTER GD 320/GWD 300 SERIES	
13	107407241	1	GASKET F. BASEPLATE 35L	
14	12222501	1	CORD SET EU L 10M	
15	12222503	1	CORD KIT UK 10M	UK
16	12222506	1	CORD SET AU/NZ L 10M	
17	107401614	1	CORD SET US/TW 3C 15.5M YELLOW	
18	12222507	1	CORD SET CH L 10M	
19	107407242	1	POWER CORD H05VV-F 2X1.00 SABS 164-1 16A	
20	140 6702 500	1	CORD SET JP 15.5M	
21	302003704	8	SCREW EJOT DELTA PT50X18WN5451	

Container 35 BSF, BDF, EDF

MAXXI35 ALTO

22-07-2013

Part List ID
MAXXIII08

5

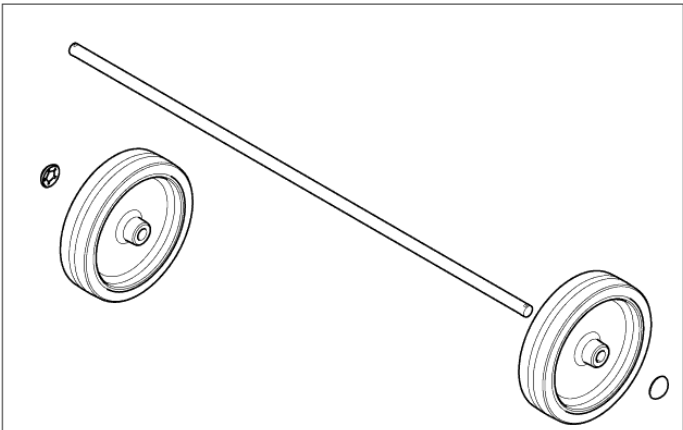

2

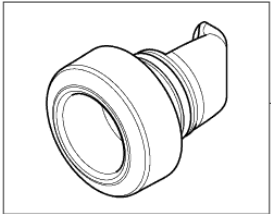

3

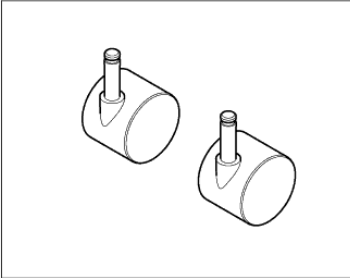

4

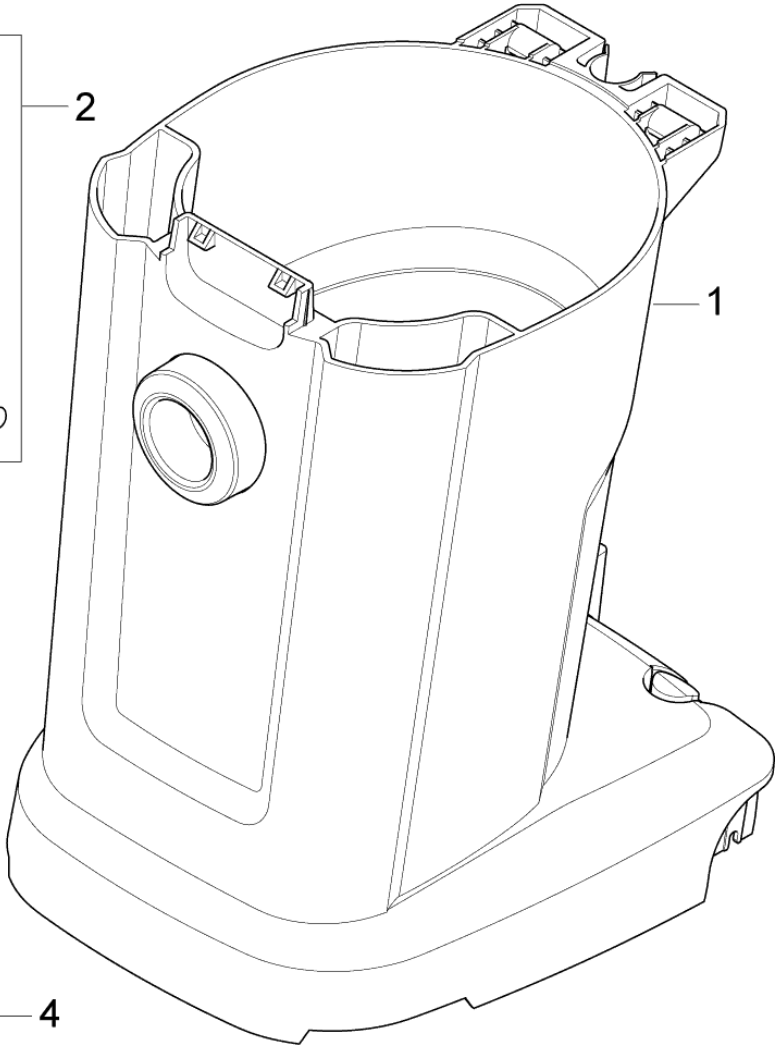

Container 35 BSF, BDF, EDF

MAXXI 35 ALTO

22-07-2013

Part List ID
MAXXIII08

6

Pos	Part no.	Qty	Description
1	107407257	1	CONTAINER WITH TROLLEY 35L MAXXI
2	140 8446 500	1	REAR WHEELS KIT 2 REAR WHEELS AND 1 STEEL
3	107407259	1	INLET ROUND MAXXI
4	140 6422 500	1	LINK WHEELS KIT 2 WHEELS

Filters and bags 35

MAXXI35 ALTO

22-07-2013

Part List ID
MAXXIII20

7

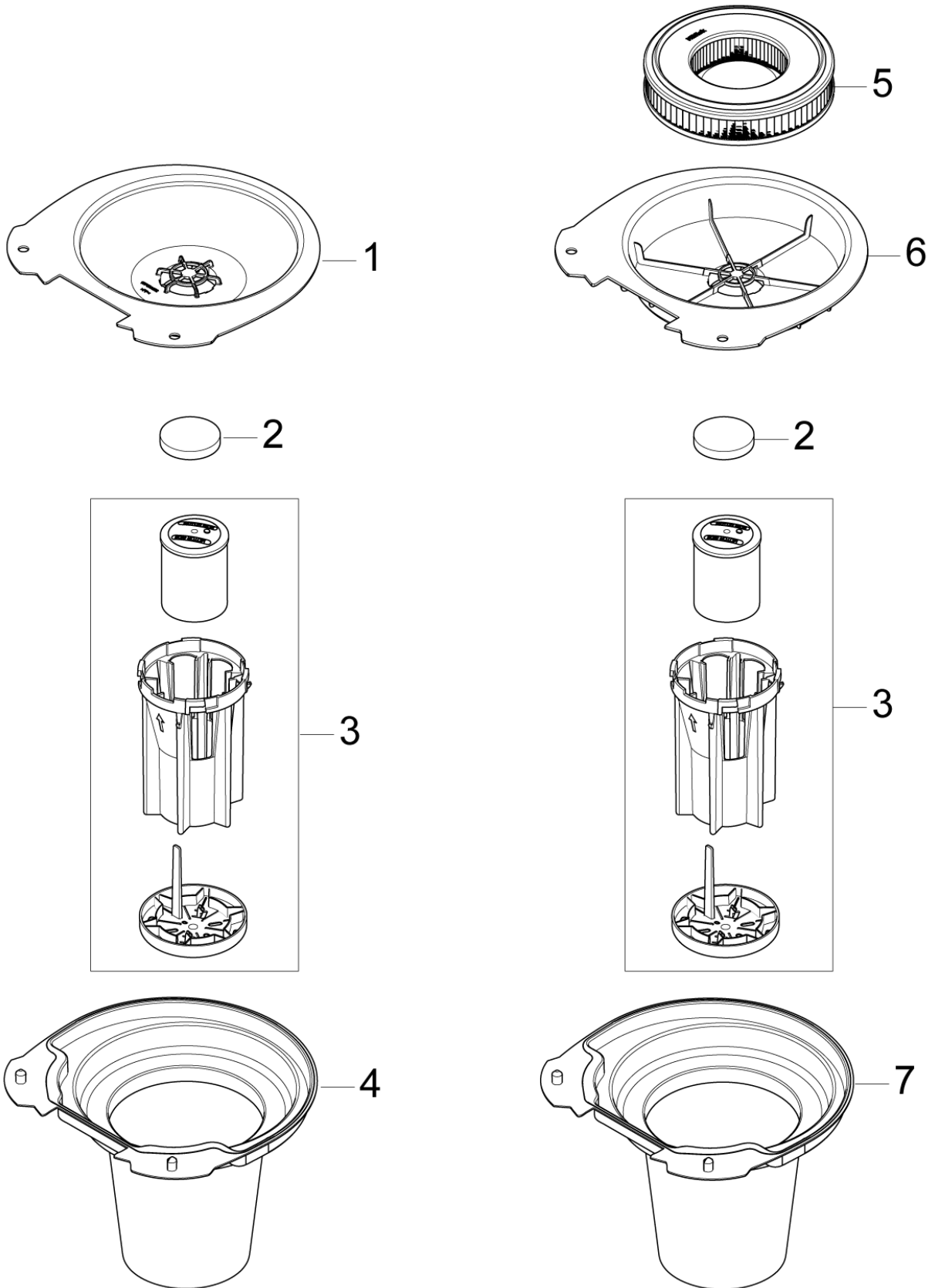

Filters and bags 35

MAXXI 35 ALTO

22-07-2013

Part List ID
MAXXIII20

8

Pos	Part no.	Qty	Description	
1	107407295	1	FLOATER ADAPTER 35L	BSF
2	140 8682 500	1	MOTOR FILTER GD 320/GWD 300 SERIES	
3	140 8680 500	1	FLOAT BASKET GWD 300 SERIES	
4	107407296	1	SACK FILTER	BSF
5	107407297	1	CARTRIGE FILTER 35L	BDF, EDF
6	107407298	1	DRYFILTER BOX 35L	BSF, EDF
7	107407299	1	WET FILTER 35L	BSF, EDF

Accessories

MAXXI 35 ALTO

22-07-2013

Part List ID
VL500ADV12

9

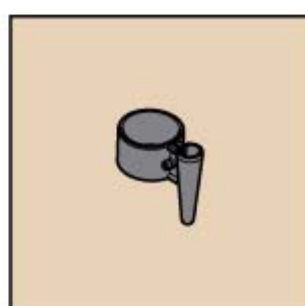
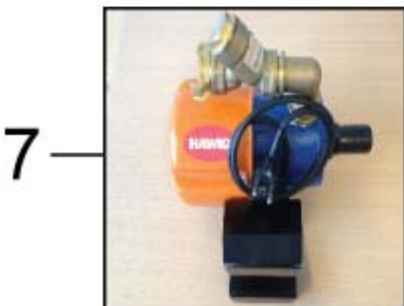
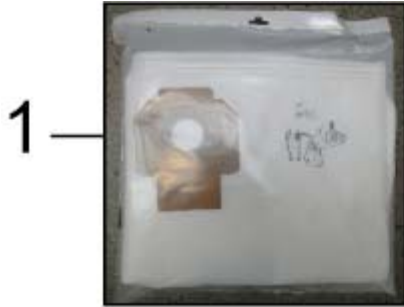

Accessories

MAXXI 35 ALTO

22-07-2013

Part List ID
VL500ADV12

10

Pos	Part no.	Qty	Description
1	302004000	1	FLEECE FILTER BAGS X 5 ATTIX 30
1	302004004	1	FLEECE FILTER BAG ATTIX 40/50 SET X 5
2	107407308	1	HOSE D32 1.9M CPL
2	107407336	1	HOSE D40 2.5M CPL
3	107407310	1	FLOOR NOZZLE D32 RUBBER STRIP
3	107407311	1	FLOOR NOZZLE D32 BRUSH
3	107407338	1	FLOOR NOZZLE D40 RUBBER STRIP
4	107407309	1	EXTENSION TUBE D32 - SS
4	107407337	1	EXTENSION TUBE D40 - SS
5	107407334	1	CREVICE NOZZLE D32
5	107408850	1	CREVICE NOZZLE D40
6	107407312	1	BRUSH NOZZLE D32
6	107407339	1	FLOOR NOZZLE D40 BRUSH
8	107407335	1	TUBEHOLDER D40

Recommended Spare Parts

MAXXI35 ALTO

22-07-2013

Part List ID
MAXXI35220

11

No Drawing For Part List

Recommended Spare Parts

MAXXI 35 ALTO

22-07-2013

Part List ID
MAXXIII35Z20

12

Pos	Part no.	Qty	Description
	107404540	1	SWITCH 0-1 DOUBLE POLE SET
	107407236	1	CLAMP F. 75-55-35 L BIN MAXXI
	107407237	1	VACUUM VALVE CPL.
	107407259	1	INLET ROUND MAXXI
	107407295	1	FLOATER ADAPTER 35L
	107407296	1	SACK FILTER
	107407297	1	CARTRIGE FILTER 35L
	107407298	1	DRYFILTER BOX 35L
	107407299	1	WET FILTER 35L
	12222501	1	CORD SET EU L 10M
	140 6422 500	1	LINK WHEELS KIT 2 WHEELS
	140 8446 500	1	REAR WHEELS KIT 2 REAR WHEELS AND 1 STEEL
	140 8680 500	1	FLOAT BASKET GWD 300 SERIES
	140 8682 500	1	MOTOR FILTER GD 320/GWD 300 SERIES
	302003384	1	Turbine kit, 1200W 230V
	302003388	1	TURBINE KIT 1000w 120v
	48338	1	FILTER was 47326