



## Electronic Service Manuals

This electronic document is provided as a service to our customers. We do not create the contents of the information contained in this document. Should you have detailed questions pertaining to the information contained in this document, you may contact Michco, or the manufacturer which provided the original information in this electronic deliverable. Michco's only part in this electronic deliverable was the electronic assembly process. By providing this manual on line we are not guaranteeing parts availability.

You may contact Michco through the following methods:

Phone (517) 484-9312 or (800) 331-3339

2011 N. High St. -- Lansing, Michigan -- 48906

Fax: (517) 484-9836

Email: [CustServe@Michco.com](mailto:CustServe@Michco.com)

Web site: [www.Michco.Com](http://www.Michco.Com)

Parts Web site: [www.FloorMachineParts.Com](http://www.FloorMachineParts.Com)

Order Parts on Line at:

**[www.FloorMachineParts.Com](http://www.FloorMachineParts.Com)**

Directly to Parts & Service:

By Email: **[Shop@Michco.com](mailto:Shop@Michco.com)**

By Fax: (517) 702-2041

By Voice: Use numbers above.

**Serving the Cleaning Industry Since 1922**

Notice: All copyrighted material remains property of original owners, all trademarks are property of respective owners. Manuals are subject to Manufacturer's reproduction limitations. Originals or reproductions were provided by manufacturers through a request. We make no warranty as to the correctness of information provided in this document and you assume all risk. By placing these manuals on line we are not declaring our corporation to be an manufacturer authorized dealer or provider, please check our web site for authorized manufacturers we represent.

# Saber Compact 20



## Walk Behind Scrubber

### Operating Instructions (ENG)

**MODELS:**                    **SC20**  
   **10052190**

**SC20T**  
   **10052200**

**SCX20T**  
   **10052370**

**SCC20**  
   **10052230**

**SCC20T**  
   **10052240**

**SCXC20T**  
   **10052420**

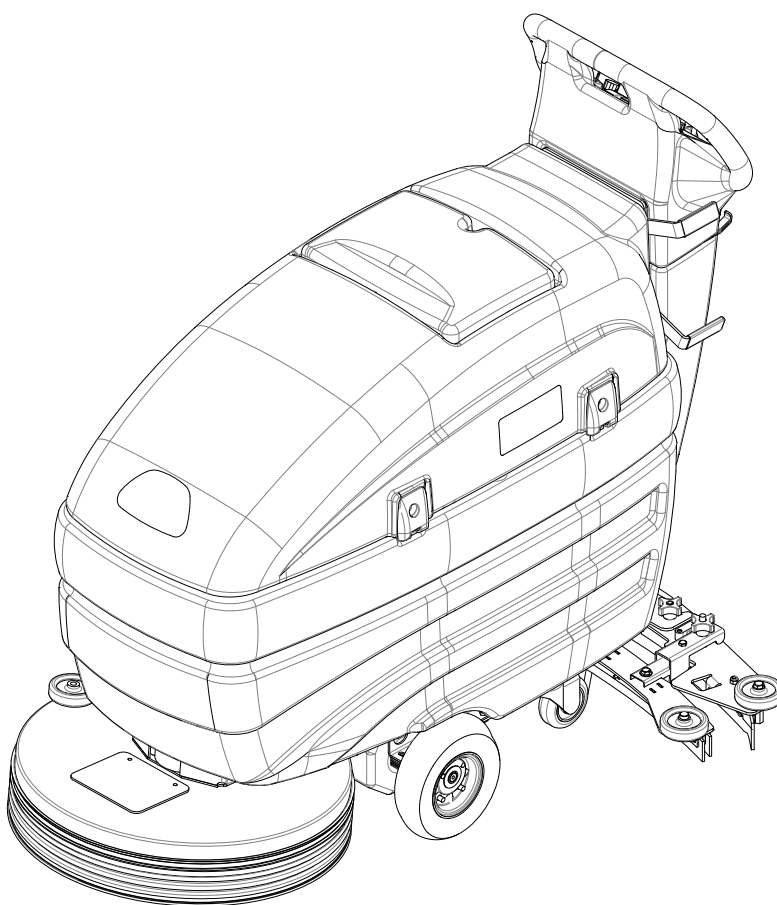

From Serial Number (Ref No1\*)  
\*See Serial Number Page in Spare  
Parts List or call manufacturer.



Model: \_\_\_\_\_

Date of Purchase: \_\_\_\_\_

Serial Number: \_\_\_\_\_

Dealer: \_\_\_\_\_

Address: \_\_\_\_\_

Phone Number: \_\_\_\_\_

Sales Representative: \_\_\_\_\_

### Overview

The Saber Compact is a battery powered, hard floor scrubber intended for commercial use. The appliance applies a cleaning solution onto a hard floor, scrubs the floor with a brush or pad, and then vacuums the soiled water back into the recovery tank.

## Warranty Registration

Thank you for purchasing a Kärcher North America product. Warranty registration is quick and easy. Your registration will allow us to serve you better over the lifetime of the product.

To register your product go to :

<http://warranty.karcherna.com/>

For customer assistance:

1-800-444-7654



**Machine Data Label . . . . .2**  
 Overview . . . . .2  
**Table of Contents . . . . .3**  
**How To Use This Manual . . . . .4**

*Safety*

IMPORTANT SAFETY INSTRUCTIONS . . . . .5  
 Hazard Intensity Level . . . . .7  
 Safety Labels . . . . .9

*Operations*

Technical Specifications . . . . .10  
 How This Machine Works . . . . .12  
 Components . . . . .13  
 Controls - Non Traction . . . . .14  
 Controls - Traction . . . . .16  
**Machine Operation . . . . .19**  
 Pre-run Machine Inspection . . . . .19  
 Starting Machine . . . . .19  
 Emergency Stop Procedures . . . . .19  
 Filling Solution Tank . . . . .19  
 Normal Scrubbing . . . . .19  
 Emptying And Cleaning Tanks . . . . .21  
 Solution Tank . . . . .21

*Maintenance*

Batteries . . . . .22  
 To Charge The Batteries . . . . .23  
 Changing Batteries . . . . .26  
 Scrub Brushes . . . . .27  
 Finished Floors . . . . .27  
 Squeegee Blades . . . . .28  
 To Remove Squeegee Assembly . . . . .28  
 Adjusting Deluxe Squeegee . . . . .28  
 To Adjust Squeegee Pitch . . . . .29  
 To Adjust Amount Of Rear Squeegee Deflection . . . . .29  
 To Replace Or Rotate Front Squeegee Blade . . . . .29  
 Greasing Axles . . . . .29  
 Service Schedule . . . . .30  
 Notes . . . . .33  
 Suggested Spare Parts - Standard . . . . .34  
 Suggested Spare Parts - Deluxe . . . . .35

## How To Use This Manual

This manual contains the following sections:

- How To Use This Manual
- Safety
- Operations
- Maintenance
- Suggested Spare Parts

The HOW TO USE THIS MANUAL section will tell you how to find important information for ordering correct repair parts.

Parts may be ordered from authorized dealers. When placing an order for parts, the machine model and machine serial number are important. Refer to the MACHINE DATA box which is filled out during the installation of your machine. The MACHINE DATA box is located on the inside of the front cover of this manual.

Model: \_\_\_\_\_  
Date of Purchase: \_\_\_\_\_  
Serial Number: \_\_\_\_\_  
Dealer: \_\_\_\_\_  
Address: \_\_\_\_\_  
Phone Number: \_\_\_\_\_  
Sales Representative: \_\_\_\_\_

The model and serial number of your machine is on the front of the control tower.

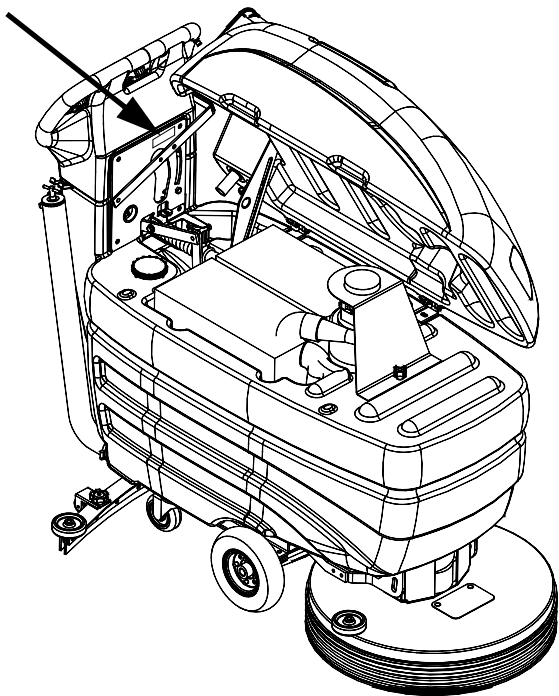

The SAFETY section contains important information regarding hazardous or unsafe practices of the machine. Levels of hazards are identified that could result in product damage, personal injury, or severe injury resulting in death.

The OPERATIONS section is to familiarize the operator with the operation and function of the machine.

The MAINTENANCE section contains preventive maintenance to keep the machine and its components in good working condition. They are listed in this general order:

- Batteries
- Scrub Brushes
- Squeegee
- Service Schedule
- Machine Troubleshooting

*NOTE: If a service or option kit is installed on your machine, be sure to keep the KIT INSTRUCTIONS which came with the kit. It contains replacement parts numbers needed for ordering future parts.*

*NOTE: The manual part number is located on the lower right corner of the front cover.*

# IMPORTANT SAFETY INSTRUCTIONS

When using this machine, basic precaution  
must always be followed, including the following:

**READ ALL INSTRUCTIONS BEFORE USING THIS MACHINE.**

**⚠ WARNING:** To reduce the risk of fire, electric shock, or injury:

**Use only** indoors. Do not use outdoors or expose to rain.

**Use only** as described in this manual. Use only manufacturer's recommended components and attachments.

If the machine is **not working properly**, has been dropped, damaged, left outdoors, or dropped into water, return it to an authorized service center.

**Do not** operate the machine with any openings blocked. Keep openings free of debris that may reduce airflow.

This machine **is not** suitable for picking up hazardous dust.

**Machine can cause a fire** when operating near flammable vapors or materials. Do not operate this machine near flammable fluids, dust or vapors.

**This machine is suitable for commercial use, for example in hotels, schools, hospitals, factories, shops and offices for more than normal housekeeping purposes.**

Maintenance and repairs **must be done** by qualified personnel.

If foam or liquid comes out of machine, **switch off immediately**.

**Disconnect** battery before cleaning or servicing.

Before the machine is discarded, the batteries **must be removed** and properly disposed of.

Make sure all warning and caution labels **are legible and properly attached** to the machine.

**During operation**, attention shall be paid to other persons, especially children.

**Before use** all covers and doors shall be put in the positions specified in the instructions.

**When leaving unattended**, secure against unintentional movement.

**The machine shall only** be operated by instructed and authorized persons.

**When leaving unattended**, switch off or lock the main power switch to prevent unauthorized use.

**Only chemicals recommended** by the manufacturer shall be used.

**This appliance has been designed** for use with the brushes specified by the manufacturer. The fitting of other brushes may affect its safety.

**Do not** use on surfaces having a gradient exceeding 2%.

## SAVE THESE INSTRUCTIONS

## MESURES DE SÉCURITÉ IMPORTANTES

**Lors de l'utilisation d'un appareil à batteries, il est nécessaire de respecter systématiquement des mesures de sécurité de base, comme suit :**

**PRENEZ NOTE DE TOUTES CES MESURES AVANT D'UTILISER CETTE MACHINE**

**⚠ AVERTISSEMENT:** Pour réduire le risque d'incendie, d'électrocution ou de blessure :

**N'utiliser cette machine** qu'en intérieur. Ne jamais l'utiliser à l'extérieur ou dans la pluie.

**N'utiliser cette machine** que comme décrit dans le présent manuel. N'utiliser que les composants et les accessoires conseillés par le fabricant.

Lorsque la machine ne **fonctionnant pas correctement**, a fait l'objet d'une chute ou d'une détérioration, a été laissée à l'extérieur, est tombée dans l'eau, la retourner au centre de service agréé.

**Ne pas opérer** la machine lorsque les conduits de ventilation sont bloqués. Débarrasser les débris des conduits, car ils peuvent réduire l'écoulement d'air.

Cette machine **n'est pas** adaptée au ramassage de poussières dangereuses

**Cette machine peut provoquer un incendie** lorsqu'elle est utilisée près de vapeurs ou de matériaux inflammables. Ne pas l'utiliser près de liquides, de poussières ou de vapeurs inflammables.

Cette machine est destinée à un usage commercial. Elle est recommandée davantage pour les domaines hôtelier, scolaire, hospitalier, industriel ou pour les bureaux, les chaînes de magasin, que pour un usage domestique normal.

L'entretien et les réparations de la machine **doivent être effectuées** par un personnel qualifié.

Si de la mousse ou du liquide sort de la machine, **la mettre hors tension immédiatement**.

**Déconnecter** les batteries avant de nettoyer la machine ou de la soumettre à un entretien.

Avant de se débarrasser de la machine, **il est nécessaire de retirer** les batteries et de les jeter correctement.

S'assurer que toutes les plaques d'avertissement ou de précaution **sont lisibles et fixées correctement** sur la machine.

**Durant la manoeuvre de la machine**, prendre garde aux personnes environnantes et notamment aux enfants.

**Avant l'utilisation de la machine**, veiller à positionner tous les couvercles et portes comme indiqué dans les instructions.

**Lorsque la machine est laissée sans surveillance**, s'assurer qu'elle ne se déplace pas de manière accidentelle.

**Cette machine ne doit être** manoeuvrée que par un personnel expérimenté et qualifié.

**Lorsque la machine est laissée sans surveillance**, la mettre hors tension ou verrouiller l'interrupteur principal afin d'empêcher un emploi non autorisé.

**Seuls les produits chimiques recommandés** par le fabricant doivent être utilisés.

**Cette machine a été conçue** pour être utilisée avec des brosses spécifiées par le fabricant.

L'utilisation d'autres brosses peut affecter sa sûreté.

N'employez pas sur des surfaces ayant un gradient de plus de 2%.

## LIRE ET CONSERVER CES INSTRUCTIONS

The following symbols are used throughout this guide as indicated in their descriptions:

### Hazard Intensity Level

There are three levels of hazard intensity identified by signal words -**WARNING** and **CAUTION** and **FOR SAFETY**. The level of hazard intensity is determined by the following definitions:

#### **WARNING:**

**WARNING** - Hazards or unsafe practices which COULD result in severe personal injury or death.

#### **CAUTION:**

**CAUTION** - Hazards or unsafe practices which could result in minor personal injury or product or property damage.

#### **FOR SAFETY: To identify actions which must be followed for safe operation of equipment.**

Report machine damage or faulty operation immediately. Do not use the machine if it is not in proper operating condition. Following is information that signals some potentially dangerous conditions to the operator or the equipment. Read this information carefully. Know when these conditions can exist. Locate all safety devices on the machine. Please take the necessary steps to train the machine operating personnel.

#### **FOR SAFETY:**

**DO NOT OPERATE MACHINE:**

Unless Trained and Authorized.

Unless Operation Guide is Read and understood.

In Flammable or Explosive areas.

In areas with possible falling objects

#### **WHEN SERVICING MACHINE:**

Avoid moving parts. Do not wear loose clothing; jackets, shirts, or sleeves when working on the machine. Use manufacturer approved replacement parts.

#### **WARNING:**

Batteries emit hydrogen gas. Explosion or fire can result. Keep sparks and open flame away. Keep solution tank in raised position when charging. Keep sparks and flames away from the batteries. Do not smoke around batteries.

#### **WARNING:**

Disconnect batteries before working on machine. Only qualified personnel should work inside machine. Always wear eye protection and protective clothing when working on or near batteries. Avoid skin contact with the acid contained in the batteries.

#### **WARNING:**

Never allow metal to lie across battery tops.

Les symboles suivants sont utilisés dans tout ce manuel, tels que décrits ici :

### NIVEAU D'INTENSITÉ DU DANGER

Il existe trois niveaux d'intensité du danger, identifiés par des termes d'avertissement - **AVERTISSEMENT**, **ATTENTION** et **POUR VOTRE SÉCURITÉ**. Le niveau d'intensité du danger est déterminé par les définitions suivantes :

#### **⚠ AVERTISSEMENT:**

**AVERTISSEMENT** - Les dangers ou des pratiques contraires à la sécurité qui POURRAIENT entraîner des blessures personnelles ou la mort.

#### **⚠ ATTENTION:**

**ATTENTION** - Les dangers ou des pratiques contraires à la sécurité qui pourraient entraîner des blessures personnelles légères ou des dégâts sur le produit ou d'autres biens.

#### **POUR DES RAISONS DE SÉCURITÉ : Pour identifier les actions qui doivent être exécutées pour un fonctionnement sûr de l'équipement.**

Signaler immédiatement tout dommage subi par la machine ou fonctionnement défectueux. Ne pas utiliser la machine si elle ne fonctionne pas correctement. Ci-dessous se trouvent les informations indiquant les conditions potentiellement dangereuses pour l'opérateur ou l'équipement. Lire attentivement ces informations. Être conscient que ces conditions peuvent survenir. Repérer tous les dispositifs de sécurité sur la machine. Suivre les étapes nécessaires de formation du personnel qui utilise la machine.

#### **POUR DES RAISONS DE SÉCURITÉ :**

**NE PAS FAIRE FONCTIONNER LA MACHINE :**

Sauf si le personnel est formé et autorisé.

Sauf si le manuel d'utilisation est lu et compris.

Dans des zones inflammables ou explosives.

Dans des zones contenant des objets susceptibles de tomber

#### **LORS DE L'ENTRETIEN DE LA MACHINE :**

Éviter les pièces mobiles. Ne pas porter de vêtements, vestes, chemises ou manches vagues lors de l'entretien de la machine. Utiliser les pièces de rechange approuvées par le fabricant.

#### **⚠ AVERTISSEMENT:**

Les batteries émettent le gaz d'hydrogène. L'explosion ou le feu peut résulter. Étincelles de subsistance et flamme nue loin. Compartiment de batterie de subsistance ouvert en chargeant. Étincelles et flammes de subsistance loin des batteries. Ne fumez pas autour des batteries.

#### **⚠ AVERTISSEMENT:**

Déconnecter les batteries avant de travailler sur la machine. La machine ne doit être confiée qu'à un personnel qualifié. Porter systématiquement des lunettes et des vêtements de protection lors d'une intervention sur les batteries ou aux alentours. Éviter tout contact de la peau avec l'acide contenu dans les batteries.

#### **⚠ AVERTISSEMENT:**

Ne jamais placer d'objets métalliques sur le dessus des batteries.

## Safety Labels

**NOTE:** These drawings indicate the location of safety labels on the machine. If at any time the labels become illegible, promptly replace them. Les schémas ci-dessous indiquent l'emplacement des plaques de sécurité. Si les plaques deviennent illisibles, les remplacer immédiatement.

**REMARQUE:** Les schémas ci-dessous indiquent l'emplacement des plaques de sécurité. Si les plaques deviennent illisibles, les remplacer immédiatement.

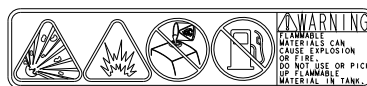

SAFETY DECAL  
86252530

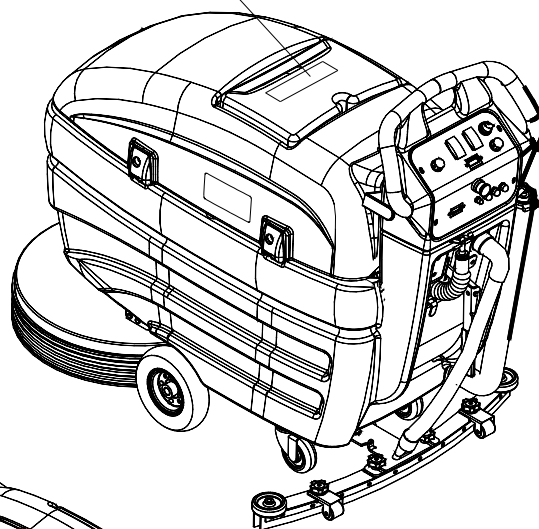

BATTERY CAUTION  
86252520

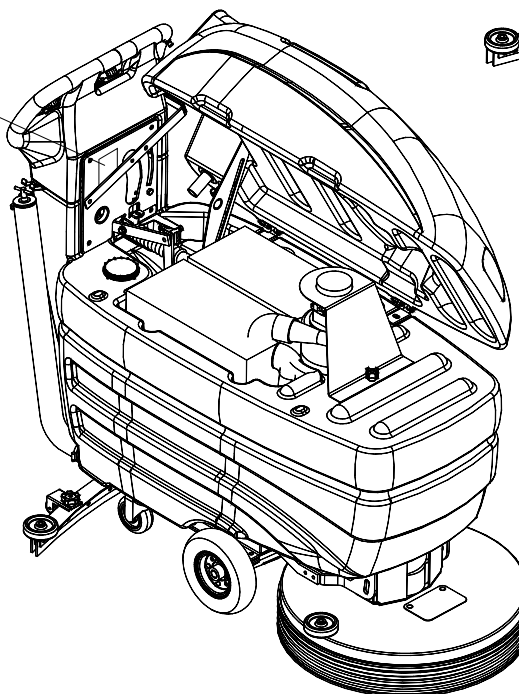

**Technical Specifications**

ITEM	DIMENSION/CAPACITY
Nominal power – non-traction model	1100 W
Nominal power – traction model	1200 W
Rated Voltage	24VDC
Rated Amperage – non-traction model	45 Amps
Rated Amperage – traction model	50 Amps
Batteries	2 x 12 Volt 105-130-195 AH @ 20hr rate
Scrub Brush Motor	.75 hp (0.56 kW)
Vacuum Motor	.75 hp (0.56 Kw)
Propelling Motor – traction model	.38 hp (0.28 Kw)
Mass (GVW) – non-traction model	543 lbs. (246.5 kg)
Mass (GVW) – traction model	556 lbs. (252.4 kg)
Weight empty without batteries – non-traction model	213 lbs. (96.1 kg)
Weight empty without batteries – traction model	232 lbs. (105.3 kg)
Solution Control – non-traction model	Gravity feed, fully variable
Solution Control – traction model	Gravity feed, fully variable with automatic shut-off in neutral
Solution tank capacity	13 gal. (50 l)
Recovery tank capacity	16 gal. (60 l)
Scrub brush diameter	20 in (51 cm)
Scrub brush pressure – non-traction model	50 lbs. (23 kg)
Scrub brush pressure – traction model	100 lbs. (45 kg)
Scrub brush speed	200 rpm
Tires – non-traction model	2 x 8 in (20 cm) thermoplastic elastomer non-marking
Tires – traction model	2 x 8 in (20 cm) foam filled non-marking
Casters	3.5 x 1.25 in (9 cm) polyurethane solid non-marking
Foundation Pressure – non-traction model	105 lbs./in <sup>2</sup> ( 725 kPa)
Foundation Pressure – traction model	46 lbs./in <sup>2</sup> ( 315 kPa)
Maximum Speed – traction model	2.75 miles/hour (4.5 km/hour)
Frame Construction	Steel with epoxy powdercoat finish.
Minimum aisle u-turn width	45 in. ( 114.3 cm)
Maximum rated climb and descent angle with empty tanks	2%
Maximum rated climb and descent angle with full tanks	2%

**Special Notes:**

The A-weighted sound pressure level emitted by the appliance was measured to be 72.5 dBA. This is a space-averaged, broad-band measurement determined according to IEC 704-I. This appliance contains no possible source of impact noise. The overall root-mean-square acceleration at the operator's arms was measured to be less than 1.0m/s<sup>2</sup>. This is a tri-axial, broad-band measurement made during normal operation on a composite tile floor.

ITEM	MEASURE
Height	43 in. ( 109.2 cm)
Length	54 in. (137.1 cm)
Width without squeegee	22 in. (55.9 cm)
Width of squeegee	31 in. ( 78.7 cm)
Width of scrub path	20 in. (51 cm)

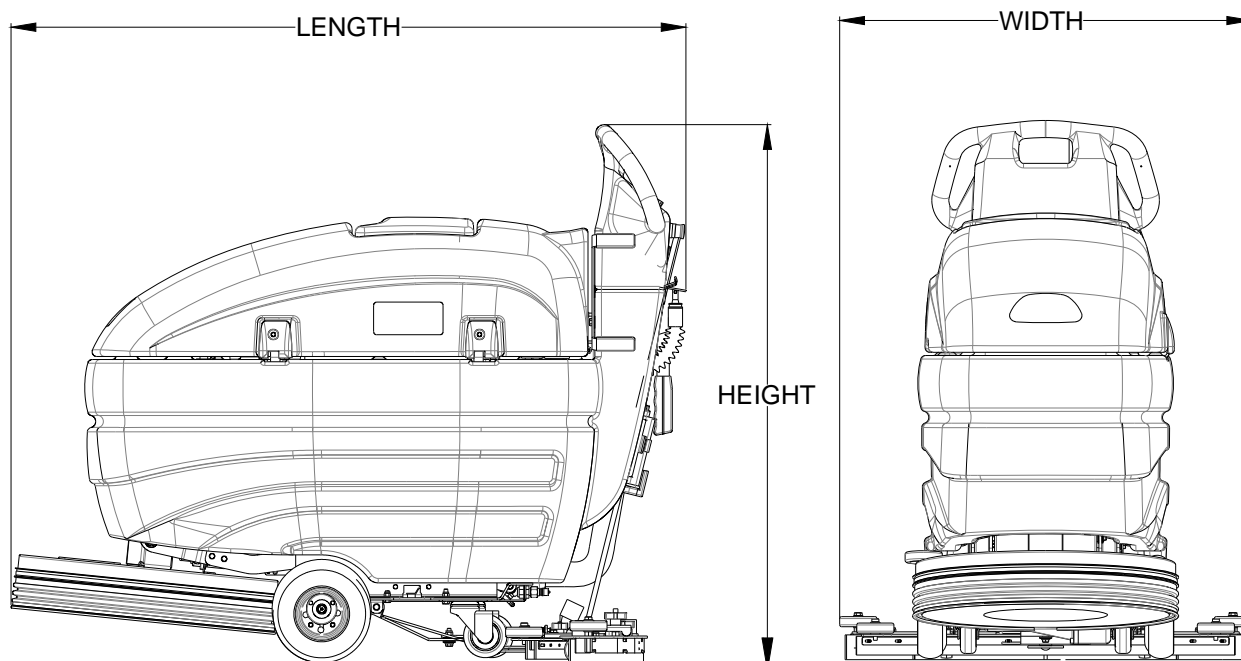

**⚠ CAUTION:**

This appliance is not intended for use by persons (including children) with reduced physical, sensory or mental capabilities, or lack of experience and knowledge, unless they have been given supervision or instruction concerning use of the appliance by a person responsible for their safety. Children should be supervised to ensure that they do not play with the appliance.

**⚠ ATTENTION:**

Cet appareil n'est pas prévu à l'usage des personnes (enfants y compris) avec des possibilités physiques, sensorielles ou mentales réduites, ou le manque d'expérience et de connaissance, à moins qu'ils aient été donnés la surveillance ou l'instruction au sujet de l'utilisation de l'appareil par une personne chargée de leur sûreté. Des enfants devraient être dirigés pour s'assurer qu'ils ne jouent pas avec l'appareil.

### How This Machine Works

The Saber Compact is a battery powered, hard floor scrubber intended for commercial use. The appliance applies a cleaning solution onto a hard floor, scrubs the floor with a brush, and then vacuums the soiled water back into the recovery tank.

The machine's primary systems are the solution system, scrub system, recovery system. The traction model has a directional control system as well.

The function of the solution system is to store cleaning solution and deliver it to the scrub system. The solution system consists of the solution tank, strainer, valve and controls. The solution tank stores cleaning solution (water and detergent) until it is delivered to the scrub system. The strainer protects the valve from debris. The non-traction model has a ball-type valve which controls the delivery of cleaning solution to the scrub system. The traction model has a solenoid type valve, which controls the delivery of cleaning solution to the scrub system. The valve automatically prevents solution flow unless the scrub brushes are turned on and the machine is being propelled. The solution control knob controls the amount of cleaning solution delivered to the scrub system.

The function of the scrub system is to scrub the floor. The scrub system consists of a rotary type disk scrub brush, motor, self-adjusting scrub deck skirt, lift linkage and controls. The brush scrubs the floor and the motor drives the brush. The brush drive hub allows the scrub brush to follow irregularities and changes in the floor without losing contact with floor. The self-adjusting scrub deck skirt controls the cleaning solution on the floor so that the squeegee can pick it up. The brush lift lever raises and lowers the scrub deck. On the traction model the brush lift lever can be locked into an increased brush pressured position.

The function of the recovery system is to vacuum the soiled water back into the recovery tank. The recovery system consists of the squeegee, vacuum motor, screen, recovery tank and controls. The squeegee wipes the dirty solution off the floor as the machine moves forward. The vacuum motor provides suction to draw the dirty solution off the floor and into the recovery tank. The screen protects the vacuum fan from debris. The recovery tank stores the dirty solution. The float ball in the tank activates when the recovery tank is full.

On the traction model, the function of the directional control system is to control the direction and speed of the machine. The directional control system consists of buttons, speed control knob/potentiometer, controller and transaxle. The speed control knob actuates a potentiometer, which signals speed. The controller interprets the forward/reverse signals from the buttons and the speed signal from the potentiometer to command the transaxle to propel the machine in the direction, and at the speed, desired.

The buttons on the control handles signal forward. When the reverse button on the control panel is pushed, in addition to either button on the control handles, reverse is signaled.

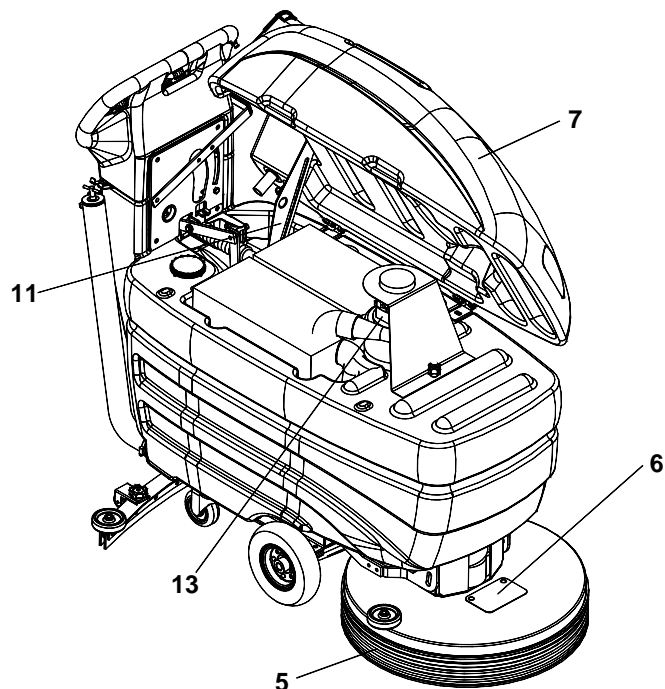
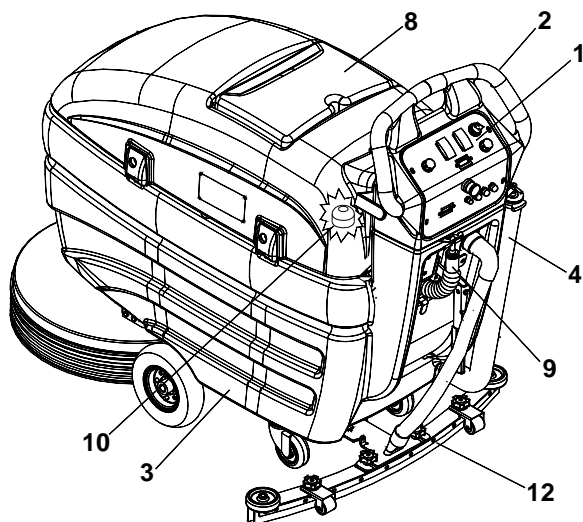

## Components

1. **Control Panel**
2. **Control Handle**
3. **Recovery Tank**
4. **Recovery Tank Drain Hose**
5. **Scrub Head**
6. **Scrub Brush Access Cover**
7. **Solution Tank**
8. **Solution Tank Cover**
9. **Solution Tank Drain Hose**
10. **Solution Strainer**
11. **Solution Tank Support Arm**
12. **Squeegee**
13. **Vacuum Motor**

**Controls - Non Traction**

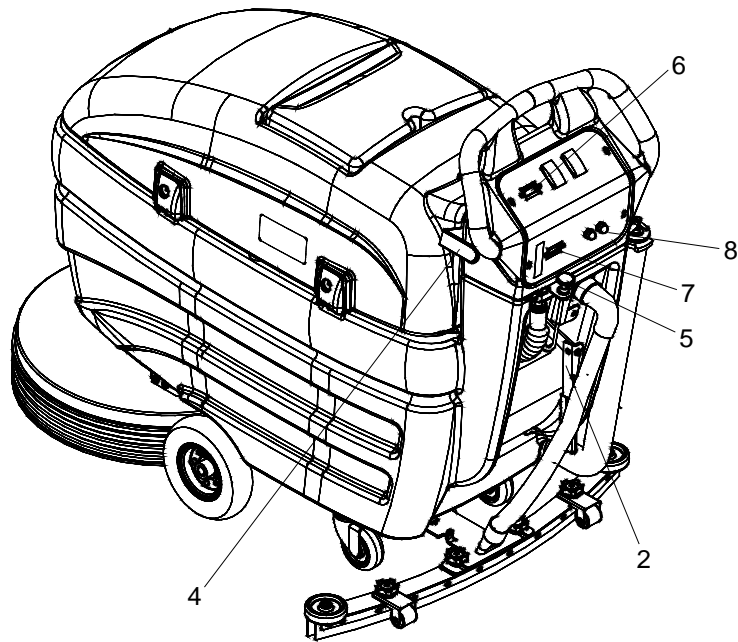
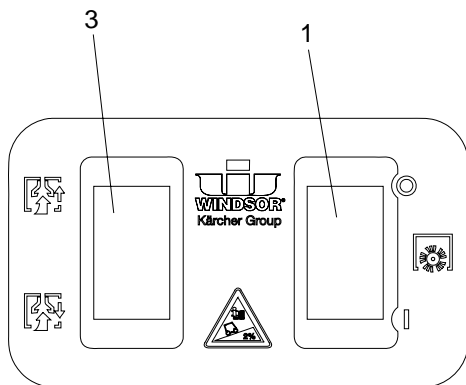

- 1. **Brush Switch**
- 2. **Brush Lift Lever**
- 3. **Vacuum Switch**
- 4. **Squeegee Lift Lever**
- 5. **Solution Control Lever**
- 6. **Battery Charge Level Indicator**
- 7. **Hour Meter (Optional)**
- 8. **Circuit Breakers**

## 1. Brush Switch

Controls the scrub brush motor.

To turn scrub brush on, press the top of the switch.

To turn scrub brush off, press the bottom of the switch.

## 2. Brush Lift Lever

Raises and lowers the brush.

To lower the brush, lift the lever from the notch, move to the left, then lower.

To raise the brush, lift the lever from its lowered position.

## 3. Vacuum Switch

Controls the vacuum motor.

To start vacuum motor, press the top of the switch.

To stop vacuum motor, press the bottom of the switch.

## 4. Squeegee Lift Lever

Raises and lowers the squeegee.

To lower the squeegee, lift and pull the lever to the left and then lower.

To raise the squeegee, lift the lever and push it to the right.

## 5. Solution Control Lever

Controls solution flow to scrub deck.

To increase flow pull and raise the knob to the desired flow.

To decrease flow push the knob down.

## 6. Battery Charge Level Indicator

Indicates the charge level of the batteries.

The meter display is divided into 10 vertical bars. Bars illuminated on the far right indicate full charge. Bars flashing near the left side indicate the batteries should be recharged. Further operation of the machine could damage the machine or the batteries.

When the machine is left overnight with less than a full charge, the display may initially indicate a full charge. It will also indicate a full charge if the batteries are disconnected, then reconnected. After a few minutes of operation the meter will give the correct charge level.

## 7. Hour Meter (Optional)

Records the number of hours the machine's brush has been in operation. This information is useful in determining when to service the machine.

## 8. Circuit Breakers

Circuit breakers interrupt the flow of power in the event of an electrical overload. When a circuit breaker is tripped, reset it by pressing the exposed button. If a circuit breaker continues to trip, the cause of the electrical overload should be found and corrected.



30 amp. Protects the vacuum motor.



30 amp. Protects the scrub brush motor.

**Controls - Traction**

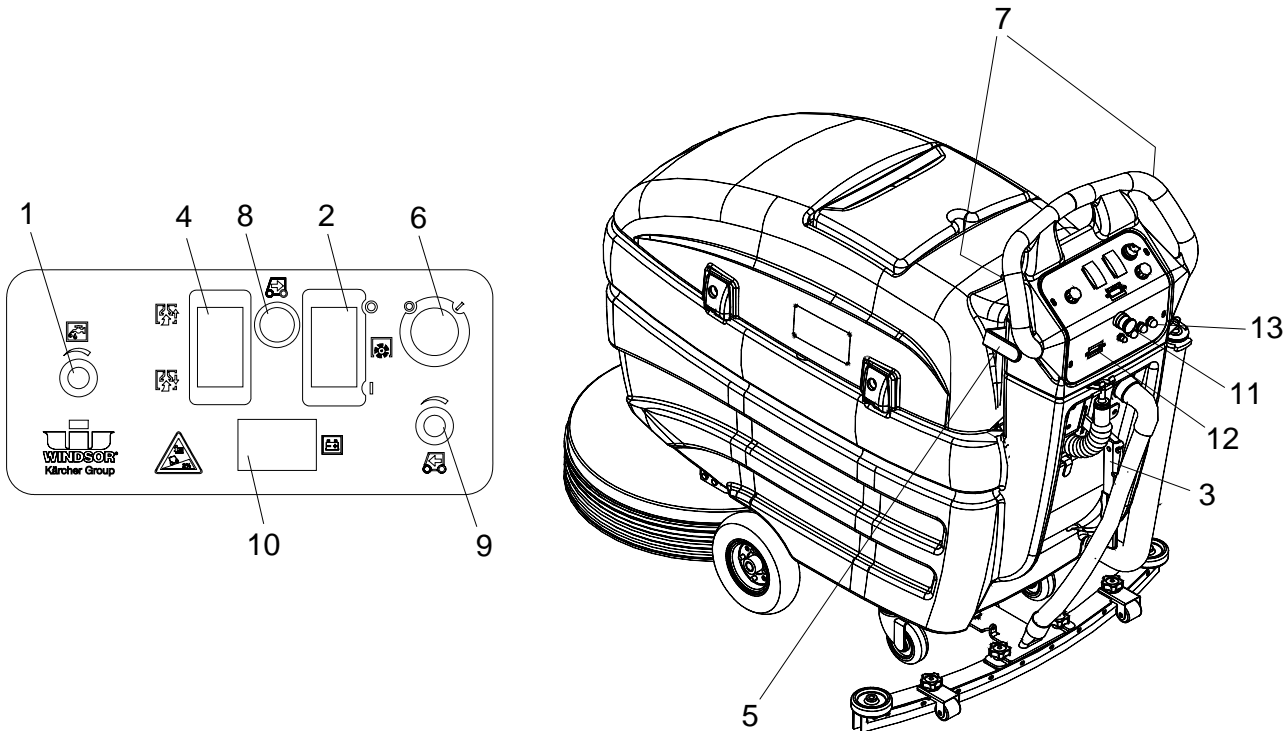

- 1. Solution Control Knob
- 2. Brush Switch
- 3. Brush Lift Lever
- 4. Vacuum Switch
- 5. Squeegee Lift Lever
- 6. Key Switch
- 7. Propel Buttons (Normally Forward)
- 8. Reverse Propel Button
- 9. Speed Control Knob
- 10. Battery Charge Level Indicator
- 11. Emergency Shut Off Switch (Optional)
- 12. Hour Meter (Optional)
- 13. Circuit Breakers

## 1. Solution Control Knob

Controls solution flow to scrub deck.

To increase flow, rotate knob clockwise.

To decrease flow, rotate knob counterclockwise.

If the brush motor is turned off or the direction control lever is in neutral, the flow is automatically interrupted until the motor is turned on again. This feature prevents unintentional draining of the solution tank and allows the operator to adjust the solution flow to the scrub deck without resetting each time the scrubbing operation is interrupted.

## 2. Brush Switch

Controls the scrub brush motor.

To turn scrub brush on, press the top of the switch. The brush will not rotate with the direction control lever in neutral.

To turn the scrub brush off, press the bottom of the switch.

## 3. Brush Lift Lever

Raises and lowers the brush.

To lower the brush, lift the lever from the notch, move to the left, then lower.

To increase brush pressure, lock the lever into the lowered position.

To raise the brush, lift the lever from its lowered position and lock into highest notch.

## 4. Vacuum Switch

Controls the vacuum motor.

To start vacuum motor, press the top of the switch.

To stop vacuum motor, press the bottom of the switch.

## 5. Squeegee Lift Lever

Raises and lowers the squeegee.

To lower the squeegee, lift and pull the lever to the left and then lower.

To raise the squeegee, lift the lever and push it to the right.

## 6. Key Switch

Controls the power for machine functions.

To turn machine on, rotate key clockwise.

To turn machine off, rotate key counterclockwise.

***FOR SAFETY: Always remove the key when machine is unattended or during service to prevent unauthorized movement.***

## 7. Propel Buttons (Normally Forward)

Controls the machine direction, scrub brush and solution flow.

To propel machine forward, push the button on either of the control handles.

The scrub brush will not rotate and the solution will not flow to the scrub deck unless a propel button is pushed.

## 8. Reverse Propel Button

Controls the machine direction in reverse.

To propel machine backward, push the button on the control panel and one of the buttons on either of the control handles.

## 9. Speed Control Knob

Controls the speed of the machine.

To increase speed, rotate knob clockwise.

To decrease speed, rotate knob counterclockwise.

## 10. Battery Charge Level Indicator

Indicates the charge level of the batteries.

The meter display is divided into 10 vertical bars. Bars illuminated on the far right indicate full charge. Bars flashing near the left side indicate the batteries should be recharged. Further operation of the machine could damage the machine or the batteries.

When the machine is left overnight with less than a full charge, the display may initially indicate a full charge. It will also indicate a full charge if the batteries are disconnected, then reconnected. After a few minutes of operation the meter will give the correct charge level.

## 11. Emergency Shut-off Switch (Optional)

Shuts off machine.

To shut off machine, push the switch.

To restart machine, rotate the switch clockwise.

## 12. Hour Meter (Optional)

Records the number of hours the machine's brush has been in operation. This information is useful in determining when to service the machine.

## 13. Circuit Breakers

Circuit breakers interrupt the flow of power in the event of an electrical overload. When a circuit breaker is tripped, reset it by pressing the exposed button. If a circuit breaker continues to trip, the cause of the electrical overload should be found and corrected.



3 amp. Protects the machine controls



30 amp. Protects the vacuum motor.



30 amp. Protects the scrub brush motor.



25 amp. Protects the scrub brush motor.

## Machine Operation

### Pre-run Machine Inspection

Do a pre-run inspection to find possible problems that could cause poor performance or lost time from breakdown. Follow the same procedure each time to avoid missing steps.

*NOTE: See maintenance section for pre-run machine inspection checklist items.*

### Starting Machine

*NOTE: Perform pre-run machine check before operating machine.*

**FOR SAFETY: Before starting machine, make sure that all safety devices are in place and operating properly.**

1. Turn the machine power on.
2. Press the directional control button(s) to move in the desired direction, if your machine is traction model.

### Emergency Stop Procedures

1. Release the directional control button(s), if your machine is traction model.
2. Turn machine power off.
3. If an electrical problem is suspected push in emergency stop button, if machine is equipped with this option.

### Filling Solution Tank

**FOR SAFETY: Before leaving or servicing machine; stop on level surface, turn off machine and remove key.**

1. Turn the machine power off.
2. Remove solution tank cover.
3. Fill the solution tank with clean water, leaving enough room for the required amount of cleaning solution. The solution tank capacity is 13 gallons (50 liters). The water must not be hotter than 140° F (60°C) to prevent damage to the tank.

4. Measure the chemical into the solution tank. Liquid chemicals should be added to the solution tank after filling with water. Dry chemicals should be thoroughly mixed before being added into the solution tank. Commercially available, high alkaline floor cleaners, are suitable for use in the solution system.

*NOTE: Read the chemical manufacturers recommended proportion instructions.*

5. Replace solution tank cover.

### **⚠ WARNING:**

**Flammable materials can cause an explosion or fire. Do not use flammable materials in the tanks.**

### **⚠ AVERTISSEMENT:**

**Les matières inflammables peuvent provoquer une explosion ou un incendie. Ne pas utiliser de matériaux inflammables dans les réservoirs.**

### Normal Scrubbing

Plan the scrubbing pattern in advance. The longest track is around the perimeter of the area to be cleaned. For efficient operation, the runs should be the longest possible without turning, stopping, or raising and lowering scrub deck/squeegee.

*NOTE: In order to achieve the best possible results, the area which is to be cleaned should be swept before scrubbing. Large debris, strings & wire must be removed to prevent being caught in the brush or squeegee.*

INEFFICIENT SCRUBBING PATH

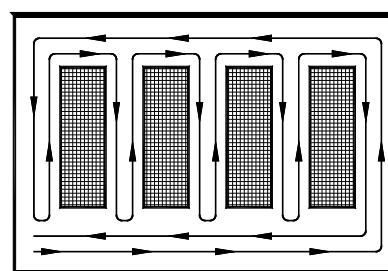

RECOMMENDED SCRUBBING PATH

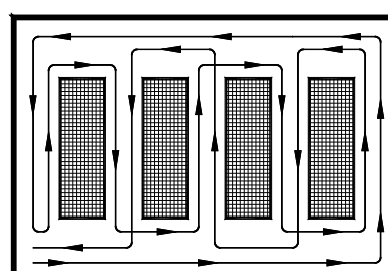

### To Begin Scrubbing

#### **⚠ CAUTION:**

When operating the machine around people, pay close attention for unexpected movement. Use extra caution around children.

#### **⚠ ATTENTION:**

Lorsque vous utilisez la machine en présence de gens, portez une attention particulière aux mouvements inattendus. Soyez plus prudent, surtout en présence d'enfants.

#### **⚠ WARNING:**

Flammable liquids and/or reactive metals can cause explosions or fire! Do not pick up.

#### **⚠ AVERTISSEMENT:**

Les liquides inflammables et / ou les métaux réactifs peuvent provoquer des explosions ou un incendie ! Ne les ramassez pas.

1. Turn the machine power on.
2. Lower the squeegee.
3. Turn the vacuum on.
4. Lower the scrub brush to the floor.
5. Turn the scrub brush on (for traction model, brush will start when machine is propelled).
6. Drive machine forward to begin scrubbing.

*NOTE: Shut machine off immediately if water or foam is expelled from the machine.*

7. Adjust the speed of the machine, solution flow and scrub brush pressure as necessary.

*NOTE: For non-traction model, the solution flow must be shut off to prevent unintentional draining of solution tank. For traction model, once solution flow rate is set it is not necessary to shut off solution when stopping scrubbing. Solution flow is automatically shut off when the brush motor stops. When the brush motor is activated, flow will automatically resume.*

### To Stop Scrubbing

1. Release the directional control button(s), if your machine is traction model.
2. Turn the scrub brush off.
3. Raise the scrub brush.
4. Raise the squeegee.
5. Turn the vacuum off.
6. Turn the machine power off.

### Double Scrub

For floors which are heavily soiled or have thick accumulations of floor finish the machine may not clean sufficiently with one pass. In these cases it will be necessary to double scrub.

To double scrub, make the first pass over the surface being cleaned with the squeegee up, vacuum off, the solution on, and brush down and on. This allows the solution to stay in contact with the soil while loosening the surface accumulation with the brush. Allow time for the first application to stay in contact with the floor. The length of time between the first and second pass depends on the amount of accumulation and the type of chemical being used. A second scrubbing with the squeegee down, vacuum on and again with solution and brush on will further loosen the soil. The additional application of solution will further assist the difficult cleaning job.

***FOR SAFETY: When using machine, go slow on inclines and slippery services.***

## Emptying And Cleaning Tanks

1. Park the machine next to a floor drain. Drain hoses are on the rear of the machine.
2. Turn the machine power off.

## Solution Tank

1. Unhook the small drain hose from the retainer. Unscrew the T-handle plug enough to loosen it, then lower the hose in the direction of the drain. Slowly remove the plug from drain hose.
2. Remove the solution tank cover.
3. Flush the solution tank out with clean water and run several gallons of clean water through systems. Do not use water hotter than 140°F (60°C) to clean the tank, damage may occur.

*NOTE: Never allow solution to remain in tank. Damage to tank, seals and valves could occur.*

4. Replace the drain plug and secure the drain hose in the bracket.

## Recovery Tank

1. Unhook the large drain hose from the retainer. Unscrew the T-handle on the plug enough to loosen it, then lower the hose in the direction of the drain. Do not stand in front of the end the of hose. Recovered solution will come out with force. Slowly remove the plug from the drain hose.
2. Raise the solution tank to access the recovery tank. Make sure the support arm is fully engaged. Remove the vacuum motor and rear access cover. Flush the recovery tank out with clean water. Do not use water hotter than 140°F (60°C) to clean the tank, damage may occur.
3. Clean off the float and check for free movement of the float ball. The float is attached to the bottom of the vacuum motor.
4. Replace the drain plug and secure the drain hose in the bracket.
5. If the machine is to be stored, leave solution tank in the raised position.

### Batteries

The batteries provide the power to operate the machine. The batteries require regular maintenance to keep them operating at peak efficiency.

The machine batteries will hold their charge for long periods of time, but they can only be charged a certain number of times. To get the greatest life from the batteries, charge them when their charge level reaches 25% of a full charge. Use a hydrometer to check the charge level.

Do not allow the batteries to remain in a discharged condition for any length of time. Never expose a discharged battery to temperatures below freezing. Discharged batteries will freeze causing cracked cases. Do not operate the machine if the batteries are in poor condition or if they have a charge level below 25% (specific gravity below 1.155).

Keep all metallic objects off the top of the batteries, as they may cause a short circuit. Replace worn or damaged cables and terminals.

Check the electrolyte level in each battery cell before and after charging the batteries. Never add acid to the batteries, use distilled water. Do not allow water level to fall below the battery plates. Portions of plates exposed to air will be destroyed. Do not overfill. Keep plugs firmly in place at all times.

#### **⚠ CAUTION:**

When servicing machine, avoid contact with battery acid.

#### **⚠ ATTENTION:**

Lors de l'entretien de la machine, évitez tout contact avec l'acide de batterie.

#### **⚠ WARNING:**

Batteries emit hydrogen gas. Explosion or fire can result. Keep sparks and open flame away. Keep covers open when charging.

#### **⚠ AVERTISSIMENT:**

Les batteries émettent du gaz hydrogène. Une explosion ou un incendie peut en résulter. Maintenez les étincelles et les flammes nues à l'écart. Gardez les carters ouverts lors du chargement.

#### **⚠ WARNING:**

Wear eye protection and protective clothing when working with batteries.

#### **⚠ AVERTISSIMENT:**

Portez des lunettes de protection et des vêtements de protection lorsque vous travaillez avec des batteries.

#### **⚠ WARNING:**

Charge batteries in a well ventilated area.

#### **⚠ AVERTISSIMENT:**

Chargez les batteries dans un endroit bien ventilé

#### Battery Maintenance

1. When cleaning the batteries, use a solution of baking soda and water. Do not allow the cleaning fluid to enter the battery cells, electrolyte will be neutralized.
2. Maintain the proper electrolyte level in each battery cell. If a cell should accidentally overflow, clean immediately.
3. Wipe off the top of the batteries at least once a week.
4. Test battery condition with a hydrometer at least once a week.
5. Ensure that all connections are tight and all corrosion removed.
6. Every 4 to 6 months, remove that batteries from the machine and clean the battery cases and battery compartment.

## Checking Battery Specific Gravity

Use a hydrometer to check the battery specific gravity.

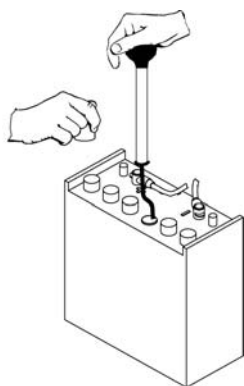

## Checking Gravity

### A. Hydrometer

### B. Battery

*NOTE: Do not take readings immediately after adding distilled water, if the water and acid are not thoroughly mixed, the reading may not be accurate.*

Check the hydrometer readings against this chart.

SPECIFIC GRAVITY @ 80 F (27°C)	BATTERY CONDITION
1.265	100% CHARGED
1.225	75% CHARGED
1.190	50% CHARGED
1.155	25% CHARGED
1.120	DISCHARGED

*NOTE: If the readings are taken when the battery electrolyte is any temperature other than 80°F (27°C), the reading must be temperature corrected.*

To find the corrected specific gravity reading when the temperature of the battery electrolyte is other than 80°F (27°): Add (+) to the specific gravity reading 0.004 (4 points), for each 10°F (6°C) above 80° (27°C).

Subtract (-) from the specific reading 0.004 (4 points), for each 10°F (6°C) below 80°F (27°C).

## To Charge The Batteries

### ⚠ WARNING:

When servicing machine, avoid contact with battery acid.

### ⚠ AVERTISSIMENT:

Lors de l'entretien de la machine, évitez tout contact avec l'acide de batterie.

### ⚠ CAUTION:

Batteries emit hydrogen gas. Explosion or fire can result. Keep sparks and open flame away. Keep covers open when charging.

### ⚠ ATTENTION:

Les batteries émettent du gaz hydrogène. Une explosion ou un incendie peut en résulter. Maintenez les étincelles et les flammes nues à l'écart. Gardez les carters ouverts lors du chargement.

### ⚠ WARNING:

Wear eye protection and protective clothing when working with batteries.

### ⚠ AVERTISSIMENT:

Portez des lunettes de protection et des vêtements de protection lorsque vous travaillez avec des batteries.

### ⚠ WARNING:

Charge batteries in a well ventilated area. Leave the battery cover open.

### ⚠ AVERTISSIMENT:

Chargez les batteries dans un endroit bien ventilé

Use a 24 volt, 20 amp maximum output, DC charger which will automatically shut off when the batteries are fully charged to charge the two battery pack.

1. Stop the machine in a clean, well ventilated area next to the charger.
2. Turn the machine power off.

**FOR SAFETY: Before leaving or servicing machine; stop on level surface, turn off machine and remove key.**

3. Drain solution tank and raise the solution tank and lock the support arm. Make sure the support arm is fully engaged.

### ⚠ WARNING:

Batteries emit hydrogen gas. Explosion or fire can result. Keep sparks and open flame away. Keep covers open when charging.

### ⚠ AVERTISSIMENT:

Les batteries émettent du gaz hydrogène. Une explosion ou un incendie peut en résulter. Maintenez les étincelles et les flammes nues à l'écart. Gardez les carters ouverts lors du chargement.

4. Check the electrolyte level in each battery cell. Before charging, add just enough distilled water to cover the plates. After charging is complete, add just enough distilled water to bring up the level to the indicator ring. If the water level is too high before charging, normal expansion rate of the electrolyte may cause an overflow. Resulting in a loss of battery acid balance and damage the machine.
5. Replace the battery caps, and leave them in place while charging.
6. Unplug the battery connector from the machine.

**FOR SAFETY: When charging, connect the charger to the batteries before connecting the charger to the AC wall outlet. Never connect the charger to the AC wall outlet first. Hazardous sparks may result.**

7. Plug the charger connector into the battery connector. Connect the charger AC plug to a wall outlet. The charger gauge should indicate that the batteries are charging.
8. When the batteries are fully charged, disconnect the charger from the AC wall outlet, then disconnect the charger from the batteries.
9. Connect the batteries to the machine connector.
10. Check the electrolyte level. It should be up to the indicator ring. If necessary, add distilled water.
11. Lower the solution tank.

### Machines equipped with onboard Charger:

1. Fully open Recovery Tank / Battery Cover or prop in partially open position using bracket (included). This will provide additional venting of batteries during charging cycle.
2. Connect charger's AC power cord to AC mains. The charger's YELLOW "AC" LED will light.

*NOTE: When charger is energized, all machine function will shut down.*

3. After several seconds, the charger's green LED will flash to indicate that charging is in process.

*NOTE: If no lights are illuminated, or yellow LED flashes, refer to the charger Product Manual Troubleshooting section.*

4. When charging is complete, both the yellow and the green LED's will remain on. The charger is now in standby mode.
5. Disconnect charger's AC power cord.
6. Raise battery cover and check the battery electrolyte level. It should be up to the indicator ring. If necessary, add distilled water.
7. Lower the battery cover.

*NOTE: For additional information about battery charger function, please see the charger Product Manual.*

### On-board Charger Battery Selection

#### **⚠️ WARNING:**

Disconnect charger from wall outlet before changing charge profiles. Failing to do so could result in electrical shock.

#### **⚠️ AVERTISSEMENT:**

Débrancher le chargeur de la prise murale avant de modifier les profils de charge. Le non-respect de cette consigne pourrait provoquer une décharge électrique.

DIPSWITCH: SW1

#### Charging Curve Table

DP1	DP2	CHARGING CURVE
ON	OFF	IUIa-ACD-for Wet batteries (default setting)
ON	ON	IUIa-O AGM-for AGM or Gel batteries (maintenance free)

Only dipswitch SW1 effects the charging curve. Select the appropriate dip switch setting from the Charging Curve Table. Do not change settings of SW2. Changing settings of SW2 dipswitch could result in charger failure.

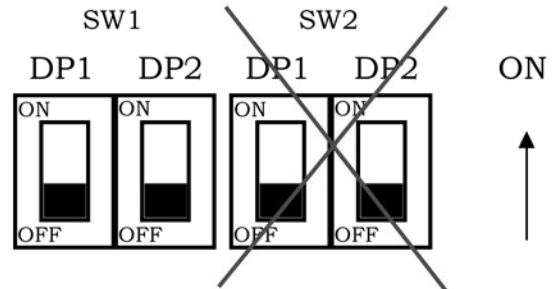

Once the appropriate charger setting has been selected, replace label. To verify charger settings, observe charger immediately after startup. When configured for lead-acid batteries, the red LED will flash twice. If configured for gel/AGM batteries the green LED will flash twice.



Dipswitches are located behind the label on the front of the charger. Peel the top right corner back to reveal two sets of dipswitches.



## Changing Batteries

Stop the machine in a clean area next to the charger. Turn off machine.

**FOR SAFETY: Before leaving or servicing the machine; stop on level surface, turn off machine and remove key.**

1. Raise the solution tank.
2. Engage solution tank support arm.
3. Disconnect battery pack from machine.
4. Use the proper size open end wrench to disconnect main ground wire first and secure cable terminal away from batteries.
5. Disconnect main positive lead and secure cable terminals away from batteries.
6. Loosen both terminals on jumper cable and remove.
7. Prepare a suitable site to place the batteries.
8. Attach suitable battery lifting device and lift batteries from the machine.

### **⚠ WARNING:**

Batteries are a potential environmental hazard. Consult your battery supplier for safe disposal methods.

### **⚠ AVERTISSIMENT:**

Les batteries constituent un danger potentiel pour l'environnement. Consultez le fournisseur de votre batterie pour connaître les méthodes d'élimination sûres.

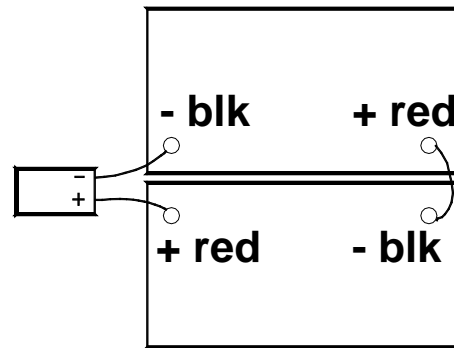

## Scrub Brushes

*NOTE: All original equipment brushes are equipped with "Perform Alert®". This feature will tell the operator when it is time to replace the scrub brush. "Perform Alert®" brushes have pre-trimmed bright yellow tufts to indicate the length of a worn out brush. When the tufts in the scrub brush wear to a length equal to the yellow tufts, the scrub brush should be replaced.*

There are five different types of brushes available to cover applications from cleaning heavily soiled floors to polishing. A pad driver is also available to take advantage of the many cleaning pads on the market and further add to the flexibility of the Saber Compact. Please refer to the following to assist in selecting the proper brush or pad for the work at hand.

### Uncoated Floors

**Aggressive Grit** is a nylon fiber impregnated with silicone carbide grit. It grinds away stain, soil, and removes surface material.

**Mild Grit** is a less aggressive silicone carbide grit suitable for cleaning medium soil conditions. Advantages are faster ground speed than nylon bristles on light solid applications.

**Nylon** is a general-purpose scrub brush with stiff bristles. Polypropylene works well for maintaining concrete, wood and tile floors.

### Finished Floors

**Nylon Polish** is the softest brush. It will gently clean finished tile or terrazzo floors without removing floor finish or floor material. Used for washing highly polished or burnished floors.

**Nylon** bristles are used in a variety of applications on coated or uncoated surfaces.

**White Pads** (Polishing) are used for dry polishing to achieve a high-gloss appearance, or surface washing on highly polished or burnished floors.

**Red Pads** (Buffing) are used for light-duty scrubbing. When used with a mild detergent they will provide surface cleaning without removing the finish.

**Blue Pads** (Scrubbing) are used for heavy-duty scrubbing and light stripping. The blue pads remove less finish than brown stripping pads, yet will remove black marks, stains and dirt.

**Brown Pads** (Stripping) are used for easy and complete removal of old floor waxes/finishes. They will quickly remove ground in dirt, black heel marks, and spills. When used with the proper stripper, this pad leaves the floor clean and ready for finishing.

The scrub brush should be checked before each days work for wire, string, wear and damage. The scrub brush should be replaced if brush bristles are missing or if yellow Perform Alert Ó indicates minimum brush length.

## Replacing Or Installing Scrub Brushes

1. With the scrub deck up, turn the machine power off.

**FOR SAFETY: Before leaving or servicing the machine; stop on level surface, turn OFF machine and remove key.**

2. Locate release lever on top of brush or pad driver. Rotate release lever counter-clockwise and the brush/pad driver will release and drop down.
3. To reinstall, center the brush driver under the brush drive hub. Raise until it contacts brush driver assembly. Turn clockwise until release lever plate locks into position.

*NOTE: Check that release plate is completely closed and pad/brush is securely attached. Damage to driver or brush could occur.*

## Squeegee Blades

The front squeegee blade allows solution to pass through channels in the blade into the squeegee assembly while maintaining vacuum to provide lift.

The rear blade wipes the floor to a near dry condition. It is important the rear blade be in good condition to properly do its job.

Check both the front and rear squeegee blades for damage and wear each day in the pre-run check. Change the front blade if it is torn or has an uneven edge. Change the rear blade if it is less than 1/2 the original thickness.

### To Remove Squeegee Assembly

1. With the squeegee in the up position, turn the machine power off.
2. Loosen both squeegee knobs and pull squeegee assembly rearward from the lifting carrier.
3. Inspect or repair as necessary and reinstall.

### To Replace Squeegee Blades

1. With the squeegee in the up position, turn the machine power off.

**FOR SAFETY: Before leaving or servicing machine; stop on level surface, turn off machine and remove key.**

2. Remove the squeegee assembly from the machine. Remove all screws and remove blade retainer strap and remove squeegee blade.
3. Replace squeegee blades as required.
4. Install blade with ribbed surface facing out.
5. Install squeegee retainer strap.
6. Install all screws starting from center and working to ends.

### Deluxe Squeegee Blades

The front squeegee blade allows solution to pass through channels in the blade into the squeegee assembly while maintaining vacuum to provide lift. The front blade has four wear surfaces and can be rotated for extended life. The front blade should not require regular replacement under normal use.

The rear blade wipes the floor to a near dry condition. It is important the rear blade be in good condition to properly do its job. Each rear squeegee blade has four wear surfaces for extended service.

Check both the front and rear squeegee blades for damage, wear, and adjustment each day in the pre-run check. Change the front blade if it is torn or has an uneven edge. Change the rear blade if it is less than 1/2 the original thickness.

### Adjusting Deluxe Squeegee

Adjusting the squeegee is a two-part process. First, the squeegee assembly must have correct pitch in order for the squeegee blade to have the same deflection at each tip as well as the center. The knob on the squeegee linkage controls the pitch adjustment. The second adjustment is the deflection.

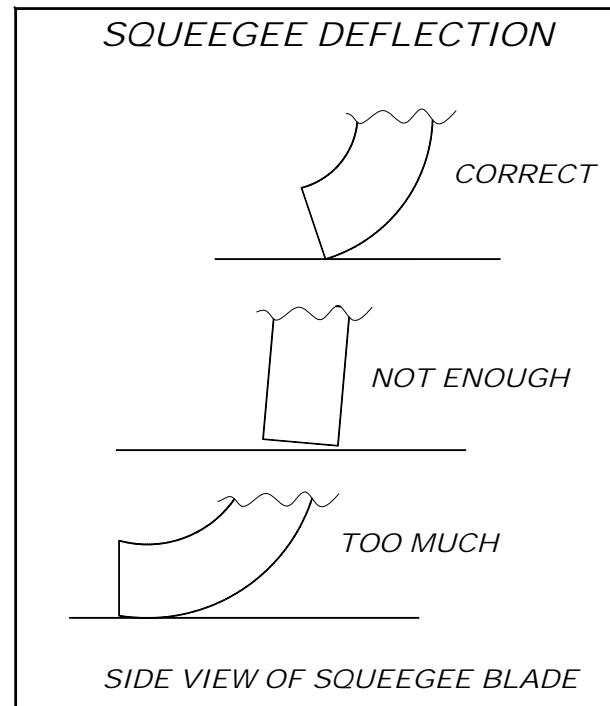
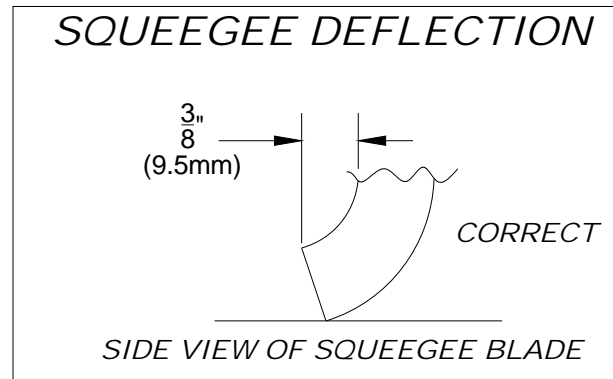

## To Adjust Squeegee Pitch

1. Choose a smooth, level surface. Turn "ON" the key switch and vacuum switch. Lower the squeegee and drive forward at least 2 feet (60cm.).
2. With the squeegee down, stop the machine. Do not allow machine to roll back.

**FOR SAFETY: Before leaving or servicing the machine, stop on level surface, turn off machine and remove key.**

3. Determine the differences, if any, in deflection of the squeegee blade between each end and the middle. Proper adjustment is obtained when deflection is equal all the way across the squeegee blade.
4. To decrease the deflection of the squeegee blade at the ends, adjust plastic knobs at the far right or left of squeegee assembly.
5. Check the deflection of the squeegee blades again. Repeat steps 1 through 4 until the deflection is equal across the entire rear squeegee blade.

## To Adjust Amount Of Rear Squeegee Deflection

1. Choose a smooth, level surface. Turn "ON" the key switch and vacuum switch. Lower the squeegee and drive forward at least 2 feet (60cm.).
2. With the squeegee down, stop the machine. Do not allow machine to roll back.

**FOR SAFETY: Before leaving or servicing machine, stop on level surface, turn off machine and remove key.**

3. Observe the amount of squeegee deflection. It should deflect approximately 3/8 in. (9.5mm) across the entire width of the squeegee.
4. To increase the squeegee deflection, turn the center knob above the lift carrier bracket clockwise. To decrease the deflection, turn the knob counter-clockwise.

*NOTE: The deflection should be consistent along the length of the squeegee. If the deflection varies from end to end the knobs can be adjusted independently to correct the variation.*

5. Turn on the key switch. Raise, then lower squeegee assembly. Drive forward at least 2 feet (60cm).
6. Repeat steps 2 through 4 until deflection of approximately 3/8 in. (9.5mm) is reached

## To Replace Or Rotate Rear Squeegee Blade

1. With the squeegee in the up position, turn key switch "OFF".

**FOR SAFETY: Before leaving or servicing machine; stop on level surface, turn off machine and remove key.**

2. Remove the squeegee assembly from the machine. Unlatch and remove blade retainer strap and remove squeegee blade.
3. Rotate the squeegee to new edge position or replace as required. Each blade has four edge positions.
4. Install blade on locating tabs of squeegee assembly.
5. Install squeegee retainer strap.
6. Fasten and lock latch, adjust latch only tight enough to take up slack in retaining strap.

## To Replace Or Rotate Front Squeegee Blade

1. With the squeegee in the up position, turn key switch "OFF".
2. Remove the squeegee from the machine. Loosen (3) thumb screws securing retainer strap.
3. Remove front retainer strap.
4. Remove squeegee's blade from locating tabs on squeegee assembly and rotate to new position or replace as required.
5. Install blade on locating tabs of squeegee tool.
6. Replace front retainer strap.
7. Secure strap by tighten (3) thumb screws.

## Greasing Axles

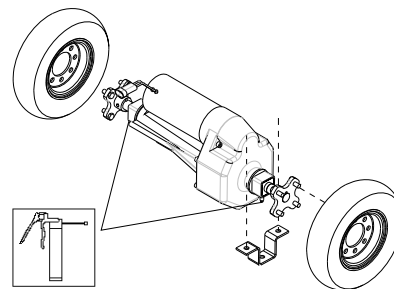

1. Apply 1-2 strokes of MOBILETEMP®78 or compatible clay-based or calcium-based grease per service schedule.

**Service Schedule**

MAINTENANCE	DAILY	WEEKLY	MONTHLY	100 HRS	200 HRS
Check batteries after charging; add water if necessary	*				
Check pad wear to prevent buildup of chemicals	*				
Check linkages and connectors for wear and damage	*				
Check hoses for wear, blockages, or damage	*				
Clean squeegee; check for adjustment; inspect for wear	*				
Check handles, switches, knobs, domes, and gaskets for damage	*				
Clean out recovery tank	*				
Clean out solution tank; remove and clean screen	*				
Clean outside of all tanks; check for damage	*				
Run vac motor for at least one minute to allow motor to dry	*				
Store with dome off tank to allow the tank to dry	*				
Check scrub deck splash skirt		*			
Check batteries for corrosion, cracks and evidence of overheating			*		
Check all bearings for noise			*		
Check all gaskets for wear and leakage			*		
Check vac motor carbon brushes			*		
Check brushes for wear; ensure bristles are not damaged			*		
Check linkages for wear and damage			*		
Grease wheels and casters			*		
Check squeegee blades for wear and frame for damage			*		
Check overall performance of machine			*		
Clean batteries and terminals				*	
Thoroughly clean the machine				*	
Check parking brake (inspect cables, linkages and pulleys)					*
Check carbon brushes in all vacuum, brush drive, and propel motors					*
Blow out dust in motors					*
Inspect motor commutators					*
Clean chains, cables and pulleys					*
Clean pivot points on squeegee and scrub deck linkages					*

PROBLEM	CAUSE	SOLUTION
Poor or no water pick-up	Debris caught on squeegee	Remove debris
	Worn squeegee blades	Replace squeegee blades
	Vacuum hose clogged	Clear obstruction from hose
	Vacuum hose disconnected from squeegee or recovery tank	Reconnect vacuum hose
	Vacuum hose damaged	Replace vacuum hose
	Vacuum motor inlet screen dirty	Clean inlet screen
	Recovery tank not sealed	Check vacuum motor position. Replace damaged seal.
	Foam filling recovery tank	Empty recovery tank Use less or different detergent Use defoamer
Vacuum motor does not run, or runs slowly	Recovery tank full	Drain recovery tank
	Circuit breaker tripped	Reset circuit breaker
	Loose connection	Check motor wires and connections
	Faulty vacuum contractor	Replace contractor
	Worn vacuum motor brushes	Replace brushes, check commutator
Poor scrubbing performance	Debris caught in scrub brush	Remove debris
	Worn brush or pad	Replace brush or pad
	Improper detergent, brush or pad used	Contact equipment or application specialist
	Low scrub brush down pressure	Increase brush pressure (traction model only)
	Low battery charge	Charge batteries
Brush motor does not run, or runs slowly	Circuit breaker tripped	Reset circuit breaker
	Loose connection	Check motor wires and connection
	Faulty brush motor contractor	Replace contractor
	Worn brush motor brushes	Replace brushes, check commutator

<b>PROBLEM</b>	<b>CAUSE</b>	<b>SOLUTION</b>
Little or no solution flow to the floor	Solution tank empty	Fill solution tank
	Solution flow turned off or set too low	Turn on or increase flow setting
	Solution strainer plugged	Clean solution strainer
	Solution hoses obstructed	Clear obstruction from hose
	Solution solenoid valve obstructed or stuck (traction model only)	Clean or replace
No power to machine	Battery disconnected	Check all battery cable connections
	Emergency shut-off activated (traction model only)	Reset
	Battery connections corroded	Clean connections
	Faulty main contactor	Replace contactor
	Faulty power switch	Replace switch
Little or no propel (traction model only)	Low battery charge	Charge batteries
	Machine turned on with directional control button(s) not in neutral	Allow control button to return to neutral. Restart
	Controller overheated	Allow cool down period
	Loose connection	Check motor wires and connection



*Suggested Spare Parts - Standard*

