



Electronic Service Manuals

This electronic document is provided as a service to our customers. We do not create the contents of the information contained in this document. Should you have detailed questions pertaining to the information contained in this document, you may contact Michco, or the manufacturer which provided the original information in this electronic deliverable. Michco's only part in this electronic deliverable was the electronic assembly process. By providing this manual on line we are not guaranteeing parts availability.

You may contact Michco through the following methods:

Phone (517) 484-9312 or (800) 331-3339

2011 N. High St. -- Lansing, Michigan -- 48906

Fax: (517) 484-9836

Email: CustServe@Michco.com

Web site: www.Michco.Com

Parts Web site: www.FloorMachineParts.Com

Order Parts on Line at:

www.FloorMachineParts.Com

Directly to Parts & Service:

By Email: **Shop@Michco.com**

By Fax: (517) 702-2041

By Voice: Use numbers above.

Serving the Cleaning Industry Since 1922

Notice: All copyrighted material remains property of original owners, all trademarks are property of respective owners. Manuals are subject to Manufacturer's reproduction limitations. Originals or reproductions were provided by manufacturers through a request. We make no warranty as to the correctness of information provided in this document and you assume all risk. By placing these manuals on line we are not declaring our corporation to be an manufacturer authorized dealer or provider, please check our web site for authorized manufacturers we represent.



www.usviper.com

DRAGON 2000RPM DUST CONTROL BURNISHER

OWNERS MANUAL

IMPORTANT: READ OWNERS MANUAL CAREFULLY
Please fill out & return your warranty card!

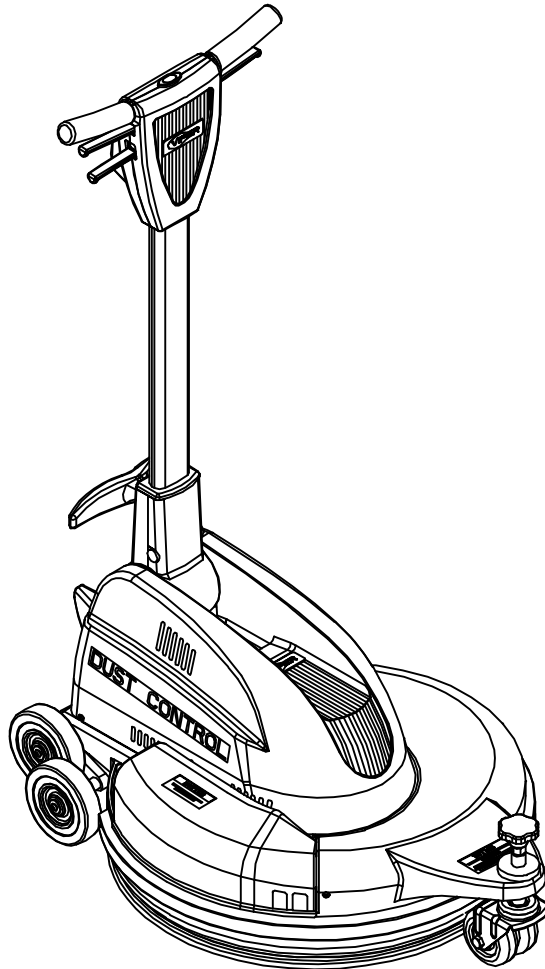

MODEL# DR2000DC

SERIAL# _____

VIPER ...exceptional
value

REV.03 (2014-9)

VF54042



TABLE OF CONTENTS

Safety Precautions	1
Machine Operation	2-3
Machine Maintenance & Storage	3
Parts Lists	4-9
Wiring Diagram	10



SAFETY PRECAUTIONS

!!! This machine must be grounded!
Grounding provides the path of least resistance for electrical current. To reduce the risk of electrical shock should the machine malfunction, the machine has a special grounding plug. Do not remove the ground pin under any circumstances!

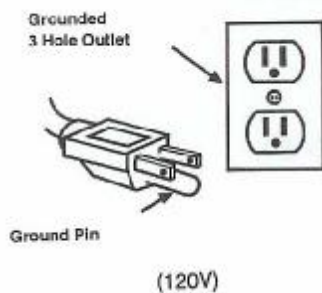

This machine is intended for commercial use. It is constructed for use in an indoor environment and is not intended for any other use. Use only recommended accessories.

All operators shall read, understand and exercise the following safety precautions:

1) Do not operate machine:

- Unless trained and authorized.
- Unless you have read and understand operators manual.
- In flammable or explosive areas.
- With damaged cord or plug.
- If not in proper operating condition.
- In outdoor areas.
- In standing water.
- Without bag / filters in place.
- With the use of extension cords.

2) Before operating machine:

- Make sure all safety devices are in place and operate properly.

3) When using machine:

- Only use approved burnishing pads.
- Do not run machine over cord.
- Do not pull machine by cord or plug.
- Do not pull cord around sharp edges or corners.
- Ensure the dust collection bag is in place and is tightly sealed to the machine.
- Turn power switch to "off " prior to unplugging machine.
- Do not unplug by pulling on the cord.
- Do not stretch cord.
- Do not handle plug with wet hands.
- Keep cord away from heated surfaces.
- Do not pick up burning or smoking debris such as cigarettes, matches or hot ashes.
- Report machine damage or faulty operation immediately.

4) Before leaving or servicing machine:

- Turn off machine.
- Unplug cord from outlet.

5) When servicing machine:

- Unplug cord from outlet.
- Use manufacturer supplied or approved replacement parts.

Operation of High Speed Floor Machine

***THIS IS A SPECIALIZED MACHINE WHICH REQUIRES THE OPERATOR TO UTILIZE A VIPER APPROVED PAD, AND MUST BE ADJUSTED PROPERLY TO ENSURE THE HIGHEST POSSIBLE PERFORMANCE AND PRODUCTIVITY.**

*Read operators manual thoroughly prior to operating or servicing this machine.

GENERAL USE

- 1] Remove any obstructions or other obstacles in the area which is to be cleaned.
- 2] Remove dust recovery bag and empty it out in a trash receptacle. Replace dust recovery bag on machine, ensuring it is sealed tightly to the machine.
- 3] Place handle in upright position and tilt machine back until handle rests on the floor.

***Be sure the machine is not plugged into an outlet.**

- 4] Remove the pad center gripping device by unscrewing the thumbscrews.
- 5] Place a "Viper approved" burnishing pad on the pad driver and re-attach the center gripping device. (check with your Viper distributor for approved pads)
- 6] Place machine back into its upright position.
- 7] Plug power cord into grounded outlet.

*Do not use an extension cord in conjunction with the standard power cord.

8] The handle height may be adjusted by lifting up on the handle release lever, located on the right side of the switch housing. Pull trigger and lower handle to desired operating position. Release trigger to lock handle into place.

9] To start the machine, push on the red safety release button located on the top of the switch housing and squeeze either switch lever.



10] Once the machine has reached operating speed, look at the digital pad pressure meter located on the top of the motor cover. There are 3 light colors which will help you determine optimal pad pressure for operating the machine. **RED LIGHT(S):** If one or both red lights are illuminated, stop the machine and turn the pad pressure

adjustment knob to the right to reduce pad pressure. **YELLOW LIGHT(S)**: If one or both yellow lights is illuminated, stop the machine and turn the pad pressure adjustment knob to the left to increase the amount of pad pressure. **GREEN LIGHT(S)**: If one, two or three green lights are illuminated, the machine is running at the optimal pad pressure and you may begin working.

- 11] When the machine is in operation, both hands should be gripping on the handle.
- 12] To stop the machine at any time, simply release the switch lever, and the machine will stop automatically.

MAINTENANCE

To keep the machine performing well for many years, please follow the following maintenance procedures.

***Always confirm that the machine is unplugged prior to performing any maintenance or repairs.**

- 1] Unplug machine as soon as you are done using it.
- 2] Remove dust recovery bag and empty contents into a trash receptacle. Inspect dust recovery bag for any damage prior to replacing it on the machine.
- 3] Clean the outside of the machine with a mild cleaner.
- 4] Check power cord for any damage. If any damage is detected, replace the cord immediately.
- 5] Lubricate wheels with a water resistant lubricant every month.

- 6] Check machine for loose or missing nuts and bolts, and replace as necessary.
- 7] If the machine is used in a dusty environment, you may remove the motor cover and blow the motor clean with compressed air. This will allow for good ventilation and help the motor run cooler.

STORAGE

- 1] Unplug machine from power source.
- 2] Store in upright position in a dry area.

PARTS LIST

BASE GROUP FOR DR2000DC

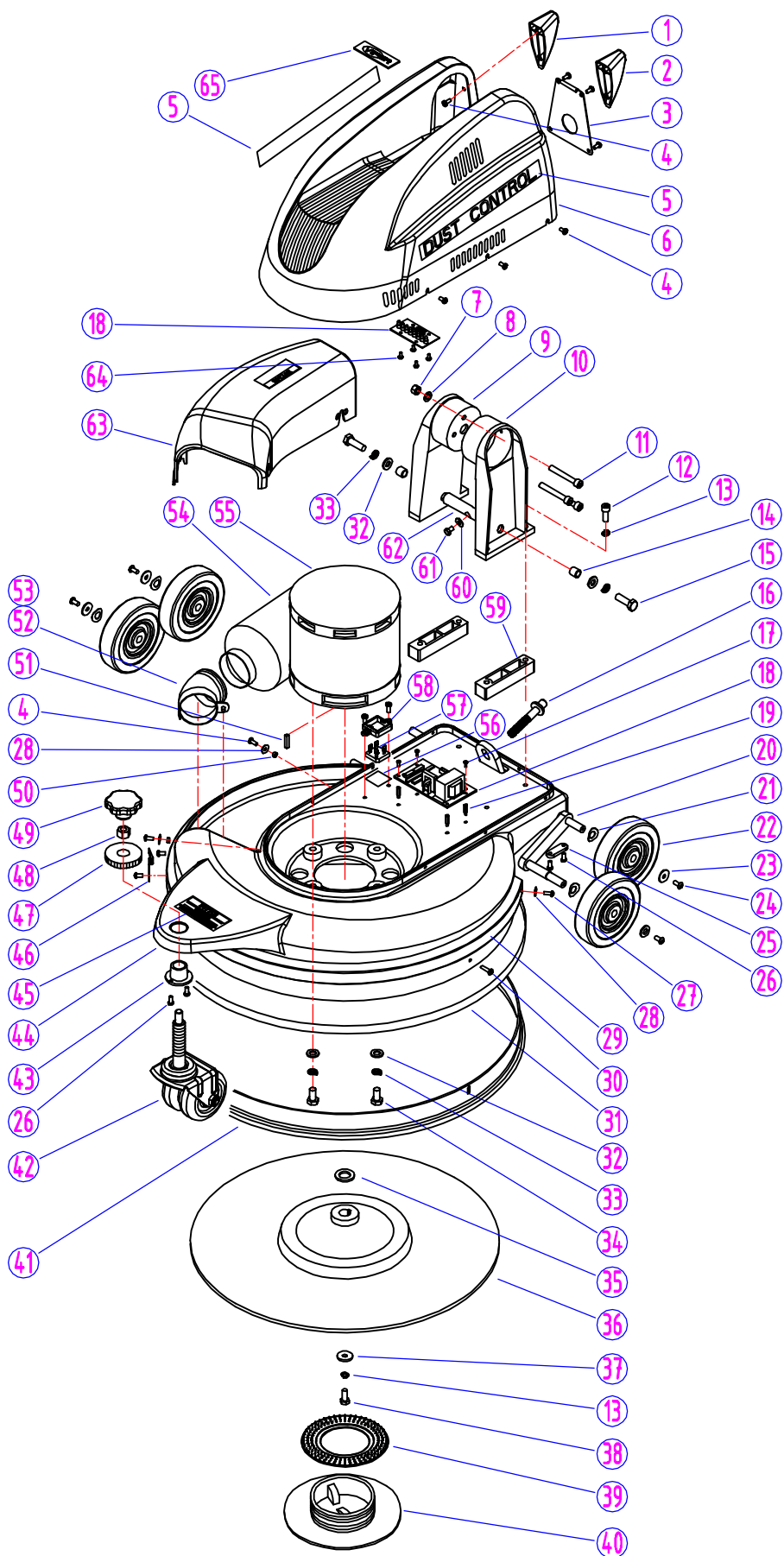

PARTS LIST

DIA NO	PART NUMBER	DESCRIPTION	NO REQ'D
1	VF52114	PLASTIC STAND, RIGHT	1
2	VF52115	PLASTIC STAND, LEFT	1
3	VF54048	CONNECTOR, MOTOR COVER	1
4	VV20509	SCREW, M5x10, PH	16
5	VF54017	LABEL	2
6	VF54047	COVER, MOTOR	1
7	VF13503	NUT, NYLON INSERT, M8	3
8	VF13524	WASHER, PLAIN	3
9	VF54020	RIGHT ARM	1
10	VF54019	LEFT ARM	1
11	GT13016	SCREW, M8x60, HEX SOCKET	3
12	VA13480	SCREW, M8x40, HEX SOCKET	4
13	VF13519	WASHER, LOCK, ϕ 8	5
14	VF54009	BUSHING	2
15	VF14007	HEX SCREW, M10x32	2
16	VF54010	ADJUSTMENT SCREW	1
17	VF14078	SCREW, M3x10, PH	4
18	ZW42540A	LED DISPLAY PANEL	1
19	VF54046	RISING SCREW	4
20	VF54004	WHEEL BRACKET	1
21	VF50119	WAVE WASHER, ϕ 12	4
22	VF52017	WHEEL, 5"	4
23	VF13666	WASHER, PLAIN, ϕ 12	4
24	VF44012	SCREW, M5x12.7	4
25	VF54005	RETAINER PLATE, AXLE	2
26	VV13621	SCREW, ST5x20	6
27	VA13474	SCREW, M5x16, PH	2
28	VF13474A	WASHER, PLAIN, ϕ 5x ϕ 16	4
29	VF54015	BUMPER	1
30	VA14010	SCREW, M5x20, PH	2
31	VF54016	CLAMP, SKIRT	1
32	VF13517	WASHER, PLAIN, ϕ 10	6
33	VF13518	WASHER, LOCK, ϕ 10	6
34	GT13097	HEX SCREW, 3/8"-16x1.25"	4
35	VF52008	SPACER	1
36	VF99024	PAD HOLDER, 20"	1
37	VF52021	WASHER, PLAIN	1
38	GT13018	HEX SCREW, M8x30	1

PARTS LIST

DIA NO	PART NUMBER	DESCRIPTION	NO REQ'D
39	VF54027	LOCK WASHER, BIG MOUTH	1
40	VF99003A	BIG MOUTH	1
41	VF54006	FLEXIBLE SKIRT	1
42	VF54011	CASTER, DUAL SWIVEL	1
43	VF54028	SCREW BUSHING, HOUSING	1
44	VF54001A	HOUSING	1
45	VF54025	ADJUSTMENT DECAL	1
46	VF54036	HOOK, COVER, DUST BAG	1
47	VF50108	NUT	1
48	VF14081	NUT, M12	1
49	VF50103A	ADJUSTING KNOB, CASTER	1
50	VF54021	SPACER	2
51	ZD40205	KEY, MOTOR SHAFT	1
52	VF54007	ELBOW ADAPTOR	1
53	VF13022	SCREW, M4x12, PH	2
54	VF54003	DUST COLLECTOR BAG	1
55	ZD40B	MOTOR, 120V	1
56	VF52022	THERMAL CONDUCTION GASKET	1
57	VF44204	RECTIFIER	1
58	VF52023	COVER, RECTIFIER	1
59	VF54040	RISER, ARM	2
60	GT13032	WASHER, PLAIN, ϕ 6x ϕ 16	1
61	VF14232	HEX SCREW, M6x10	1
62	VF54008	PIVOT BLOCK, ADJUSTOR	1
63	VF54014	COVER, DUST BAG	1
64	VF13544	SCREW, ST4x10	4
65	VF47035A	"VIPER" LOGO	1

HANDLE GROUP FOR DR2000DC

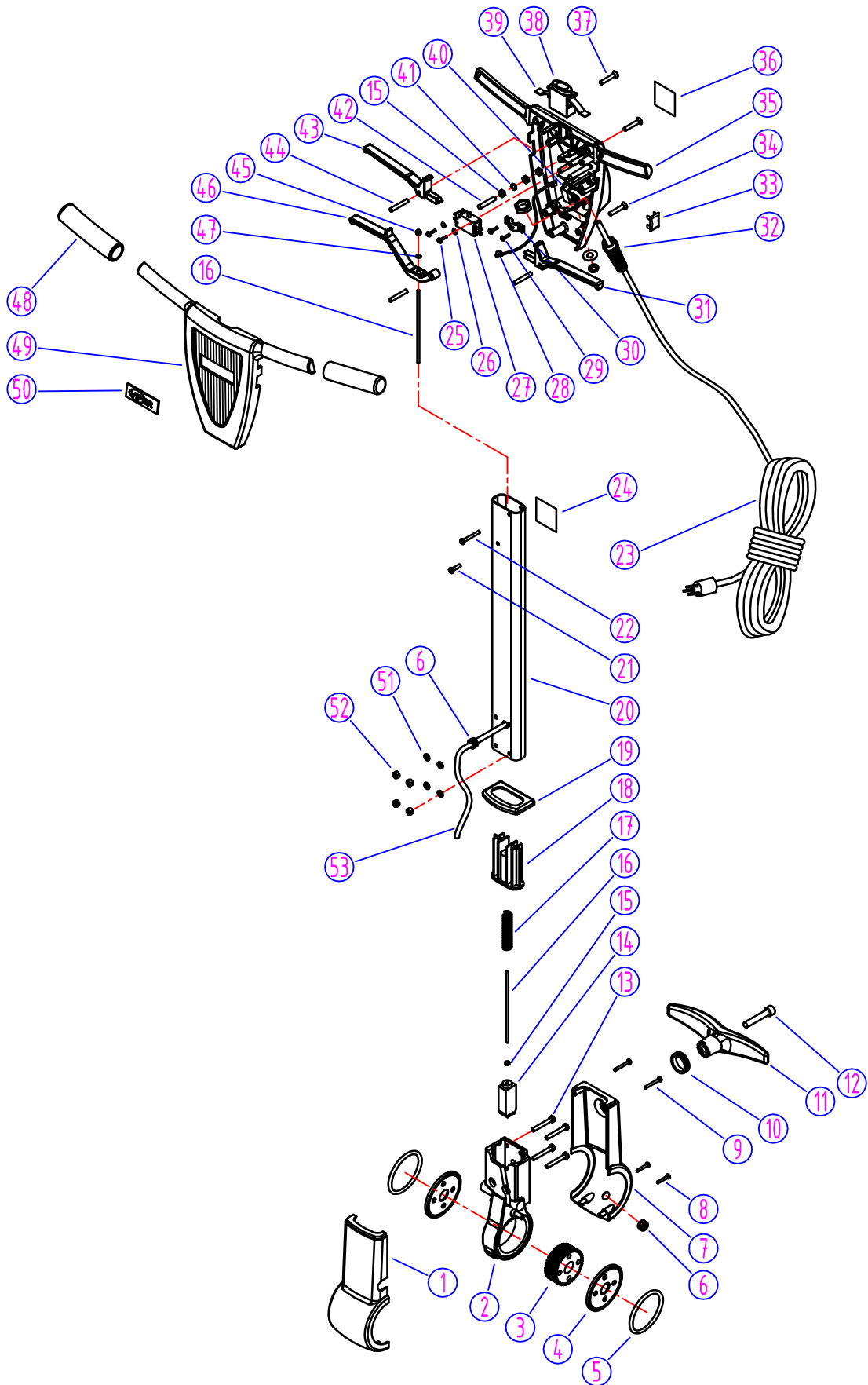

PARTS LIST

DIA NO	PART NUMBER	DESCRIPTION	NO REQ'D
1	VF47009	FRONT COVER, GEAR SEAT	1
2	VF54037	GEAR SEAT	1
3	VF47028	GEAR & LEVELING INSERT KIT	1
4	GV40227	WASHER, NYLON	2
5	GV40228	"O" RING, GEAR SEAT	2
6	VF50120A	GROMMET	2
7	VF47015	REAR COVER, GEAR SEAT	1
8	VF14080	SELF-TAPPING SCREW, ST4x25	2
9	VF14000	SELF-TAPPING SCREW, ST4x35	2
10	VF47046	SEAL RING	1
11	VF47045A	HOOK, CABLE	1
12	VF13616	SCREW, HEX SOCKET, M10x55	1
13	GT13019	HEX SCREW, M6x40	4
14	VF47052	GEAR & LEVELING INSERT KIT	1
15	GT13013	NUT, M4	4
16	VF47103	LEVELING ROD	1
17	VF47007	SPRING, LEVELING	1
18	VF47033	RETAINER	1
19	VF47008	SEAL, TUBE	1
20	VF47102	TUBE	1
21	VA13474	SCREW, M5x16, PH	1
22	VA13476	SCREW, M5x40, PH	1
23	VF45119	CORD, POWER SUPPLY, STOW 14/3C	1
24	VF54043	SERIAL TAG	1
25	VF14212	SCREW, M3x25, PH	2
26	VF13511	WASHER, LOCK, INTERNAL TOOTH	2
27	VF44203	SWITCH ASSY, 20A, 250V	1
28	VF45124A	JUMP WIRE	1
29	VV13650	SCREW, M4x10, PH	2
30	VF48309	BLOCK, HANDLE CABLE	1
31	VF46703	OPERATING TRIGGER, LEFT	1
32	AS22009	STRAIN RELIEF, CORD	1
33	VF52107	COVER, SOLUTION LEVER	1
34	VF14226	SCREW, FH, M6X35	2
35	VF52118	REAR COVER, SWITCH HOUSING	1
36	VF54029	DECAL, NOTICE	1
37	VF14218	SCREW, M6x40, PH	2
38	VF46705	SAFETY BLOCK	1

PARTS LIST

DIA NO	PART NUMBER	DESCRIPTION	NO REQ'D
39	GV40218	SPRING, SAFETY BLOCK	1
40	VF99010C	CIRCUIT BREAKER, 17A	1
41	VF13527	EXTERNAL TOOTH, WASHER, ϕ 4	1
42	VF13526	SCREW, HOLDING, M4x30	1
43	VF46704	OPERATING TRIGGER, RIGHT	1
44	VF48306	PIN, LEVER	3
45	GT13014	NUT, M4, NYLON INSERT	1
46	VF46707	TRIGGER, HANDLE ADJUSTMENT	1
47	GT13017	BIG WASHER, PLAIN, ϕ 4x ϕ 16	1
48	VF46706	HANDLE GRIP	2
49	VF46701	FRONT COVER, SWITCH HOUSING	1
50	VF47035A	"VIPER" LOGO	1
51	VF13600	WASHER, PLAIN, ϕ 6	4
52	VF13502	NUT, NYLON INSERT, M6	4
53	VF45120	CABLE, HANDLE, SJTW 14/3C	1

Wiring Diagram

DR2000DC

