



Electronic Service Manuals

This electronic document is provided as a service to our customers. We do not create the contents of the information contained in this document. Should you have detailed questions pertaining to the information contained in this document, you may contact Michco, or the manufacturer which provided the original information in this electronic deliverable. Michco's only part in this electronic deliverable was the electronic assembly process. By providing this manual online we are not guaranteeing parts availability.

You may contact Michco through the following methods:

Phone (517) 484-9312

2011 N. High St. -- Lansing, Michigan -- 48906

Fax: (517) 484-9836

Email: CustomerService@Michco.com

Website: www.Michco.Com

Order Parts online at:

www.Michco.Com

Directly to Parts & Service:

By Email: **CustomerService@Michco.com**

By Fax: (517) 484-9836

By Voice: (517) 484-9312

Serving the Cleaning Industry Since 1922

Notice: All copyrighted material remains property of original owners, all trademarks are property of respective owners. Manuals are subject to Manufacturer's reproduction limitations. Originals or reproductions were provided by manufacturers through a request. We make no warranty as to the correctness of information provided in this document and you assume all risk. By placing these manuals on line we are not declaring our corporation to be an manufacturer authorized dealer or provider, please check our web site for authorized manufacturers we represent.



V-WD-24

Wet/Dry Vacuum

Parts Manual

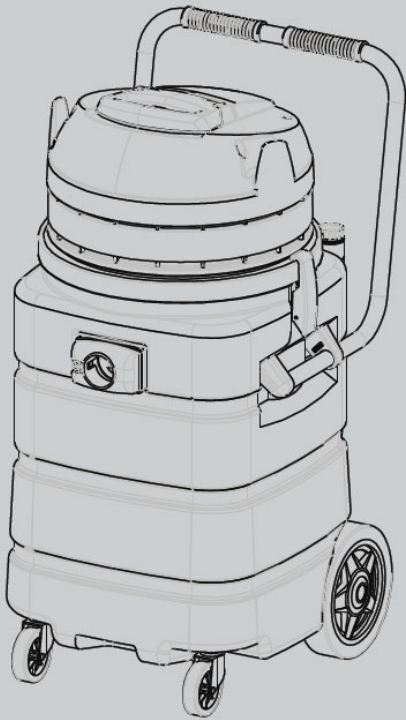

Model Part No.:
1245656 V-WD-24 [120V]

TennantTrue® Parts

North America



To view, print or download the
parts manual, visit:

www.tennantco.com/manuals

9018767
Rev. 01 (06-2019)

Only use TENNANT Company supplied or equivalent parts.
Parts and supplies may be ordered online, by phone or from any Tennant or Nobles
Authorized Service Center or Distributor.

Before Ordering any parts or supplies, be sure to have the machine model number and
serial number available.

Tennant Company
PO Box 1452
Minneapolis, MN 55440 USA
Phone: (800) 553-8033
www.tennantco.com
www.nobles.com

Specifications and parts are subject to change without notice.
Copyright ©2019 TENNANT Company

TABLE OF CONTENTS

HEAD ASSEMBLY4
TANK ASSEMBLY 6
MAIN FILTER ASSEMBLY8
VACUUM BAGS AND FILTERS8
STANDARD ACCESSORY TOOLS9
OPTIONAL SQUEEGEE ATTACHMENT KIT11
OPTIONAL SQUEEGEE ASSEMBLY11
LABEL KIT12
ELECTRICAL DIAGRAM12

RECOMMENDED SPARE PARTS LIST

VACUUM BAGS AND FILTERS	
KTRIO5851	BAG, VACUUM, MICROFIBER [1 PKG=10 BAGS]
KTRIO2912	BAG, PAPER [10 PACK]
KTRIO5840	FILTER KIT, VACUUM, MAIN
KTRIO5846	FILTER, VACUUM, PRE-FILTER
OPTIONAL HEPA FILTER	
KTRIO5808	FILTER KIT, CARTRIDGE, HEPA W/RING & GASKET
KTRIO5801	FILTER, CARTRIDGE, HEPA
KTRIO5839	RING, FASTENER, PLASTIC
CLEANING TOOL ACCESSORIES	
KTRIO5786	WAND SET, VACUUM, TWO-PIECE
KTRIO5804	HANDLE, VACUUM HOSE
KTRIO5811	HOSE ASSY, VACUUM, 5M, Ø38 MM
1064520	TOOL, FLOOR, WET, 038 mm
1064519	TOOL, FLOOR, DRY
KTRIO5608	KIT, TOOL, DRY, 038 mm
KTRIO5821	TOOL, FLOOR, CARPET
OPTIONAL SQUEEGEE SYSTEM	
KTRIO5342	SQUEEGEE KIT, VACUUM, WITH BRACKET
KTRIO5783	BLADE SET, SQGE
KTRIO5667	HOSE KIT, SQUEEGEE
KTRIO5784	KNOB SET, SQGE, YELLOW
KTRIO5714	WHEEL KIT, SQGE, WALL ROLLER
KTRIO5715	WHEEL KIT, SQGE, FLOOR SUPPORT
KTRIO5716	CLAMP KIT, SQUEEGEE
GENERAL MAINTENANCE PARTS	
KTRIO5657	CASTER KIT, VACUUM [QTY 2]
KTRIO5762	CORD KIT, POWER, PIGTAIL, 120VAC, YEL
KTRIO5352	CORD KIT, POWER, W/ CORD RESTRAINT CLIP
KTRIO5660	FLOAT KIT, VACUUM, BASKET
KTRIO5606	LATCH KIT, VACUUM [QTY 2]
KTRIO5765	MOTOR KIT, VACUUM, 1000W, 120V/60HZ
1021646	SWITCH, ON/OFF
KTRIO5660	HOSE KIT, DRAIN , W/CAP
KTRIO2728	CLIP KIT, HANDLE, D.25
KTRIO5769	CLAMP KIT, DRAIN HOSE

HEAD ASSEMBLY

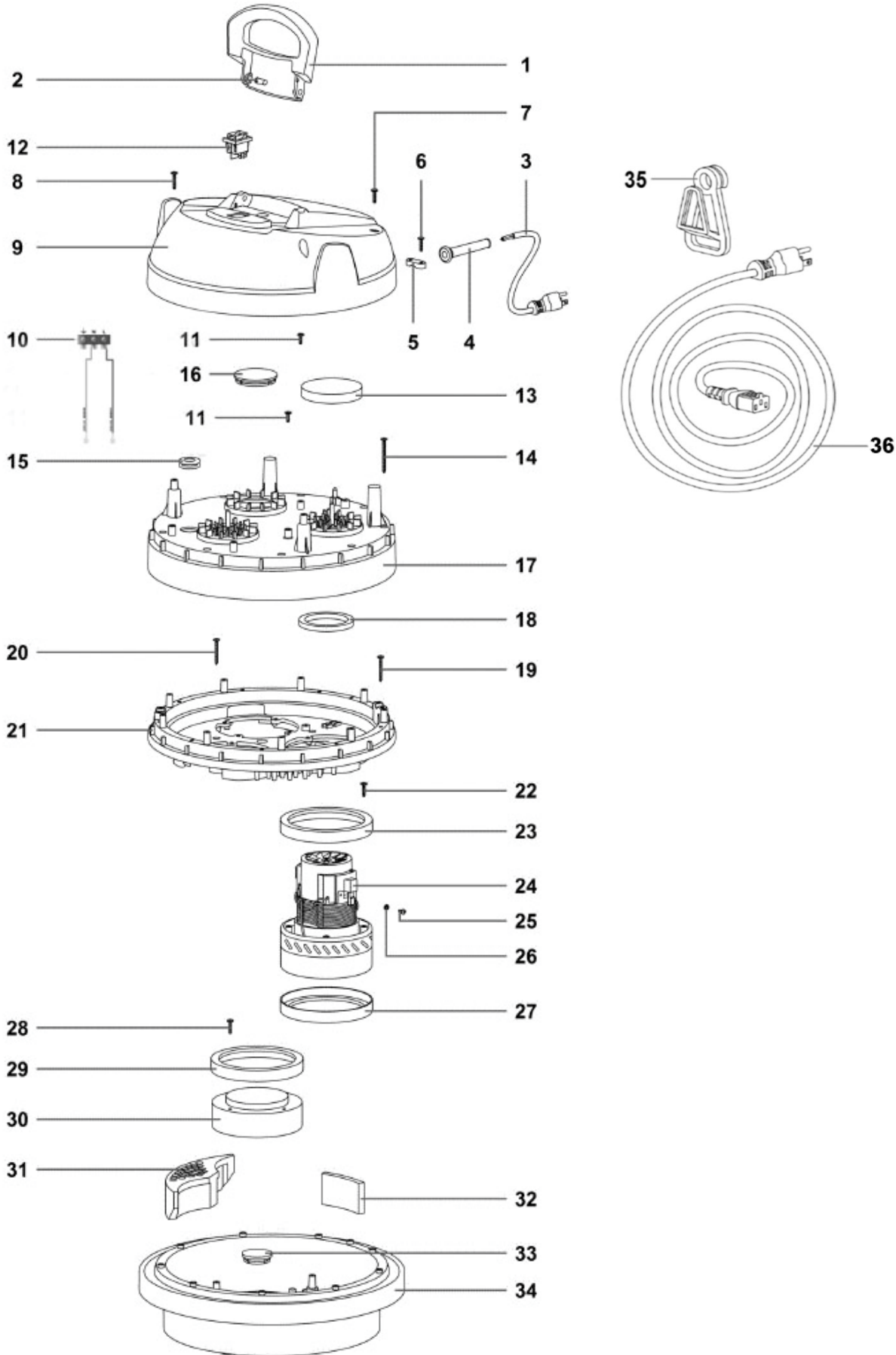

HEAD ASSEMBLY

Code	Part No.	Description	Qty
▽	KTRI05766	HOUSING ASSY, POWER, HEAD [V-WD-24]	1
▲ ▽	KTRI05761	COVER KIT, VACUUM, GRAY	1
▲ ▲ 1	N/A	HANDLE VEGAS G55 AUTOEST.	1
▲ ▲ 2	N/A	HANDLE PIN VEGAS	2
▲ ▲ 7	1021628	SCREW PFU TMT PHL 5X20 BLACK	2
▲ ▲ 8	N/A	SCREW PFU TMT PHL 5X25 ZN BLACK	2
▲ ▲ 9	N/A	COVER VEGAS 600 G55 AU 1 INT.	1
▲ ▽	KTRI05762	CORD KIT, POWER, PIGTAIL, 120VAC, YEL	1
▲ ▲ 3	N/A	POWER CORD 3X16AWG	1
▲ ▲ 4	N/A	FAIR-LEAD LONG	1
▲ ▲ 5	1021626	CABLE CLAMP	1
▲ ▲ 6	1021628	SCREW PFU TMT PHL 5X20 BLACK	1
▲ ▽	KTRI05764	TERMINAL KIT, VACUUM, W/WIRES	1
▲ ▲ 10	N/A	KIT ELET.600 1MOT. AUTOEST.	1
▲ ▲ 11	1021706	SCREW PAT TMT PHL 5X14 ZN BLACK	1
▲ 12	1021646	SWITCH, ON/OFF	1
▲ 13	1021647	FILTER, FOAM	1
▲ 14	1021710	SCREW PAT TMT PHL 5X55 BLACK	9
▲ 15	1021711	GUIDING SLIT FOR QUICK COUPLING	1
▲ 16	N/A	CAP COVER SELF-EXTINGUISHING	2
▲ 17	N/A	COVERING 600 AU NERO	1
▲ 18	1021651	WASHER H8 D85X65	1
▲ 19	1021714	SCREW PAT TMT PHL 5X40 BLACK	9
▲ 20	1021714	SCREW PAT TMT PHL 5X40 BLACK	3
▲ 21	N/A	MOTOR FASTENER NEV. 600 AU NERO	1
▲ 22	1021628	SCREW PFU TMT PHL 5X20 BLACK	4
▲ ▽	KTRI05765	MOTOR KIT, VACUUM, 1000W, 120V/60HZ	1
▲ ▲ 24	N/A	MOTOR BD381 AU 1000W 120/60	1
▲ ▲ 25	N/A	TOOTHED WASHER M4 UNI 8842	1
▲ ▲ 26	N/A	SCREW TC CROSS M 4X8 UNI 7687	1
▲ ▲ N/S	N/A	WIRING 50CM MOTOR POKE-IN UL	1
▲ ▲ N/S	N/A	CLAMP	1
▲ ▲ N/S	N/A	CONN.WIRE M.AWG-18 400-G/V-FF-4,2	1
▲ ▽	KTRI05618	GASKET KIT, MOTOR, 120VAC	1
▲ ▲ 23	1021657	"L" GASKET W/O HOLES H=5,5	1
▲ ▲ 27	1021657	"L" GASKET W/O HOLES H=5,5	1
▲ ▲ 28	1021628	SCREW PFU TMT PHL 5X20 BLACK	8
▲ ▲ 29	1021657	"L" GASKET W/O HOLES H=5,5	2
▲ ▲ 30	N/A	FAKE MOTOR LOWERED AU	2
▲ 31	1021720	DAMPER, SOUND [V14]	3
▲ ▽	KTRI05639	BASE, HOUSING KIT, GRAY [V-WD-24P]	1
▲ ▲ 32	1021721	GASKET MTP/30 AU-AD 50X10X85	3
▲ ▲ 33	1021723	BASE CAP	2
▲ ▲ 34	N/A	BASE 600/400 G55 AU. COMP.	1
▲ ▽	KTRI05352	CORD KIT, POWER, W/ CORD RESTRAINT CLIP	1
▲ ▲ 35	N/A	CORD RESTRAINT	1
▲ ▲ 36	N/A	CORD, POWER, DETACHABLE	1
▲ N/S	N/A	LABEL, LOGO, 04.3L DUAL [TENNANT/NOBLES]	1
▲ N/S	N/A	LABEL, WARNING, UL	1

▽ KIT

▲ INCLUDED IN KIT

N/A = NOT AVAILABLE SEPARATELY - MUST ORDER KIT

TANK ASSEMBLY

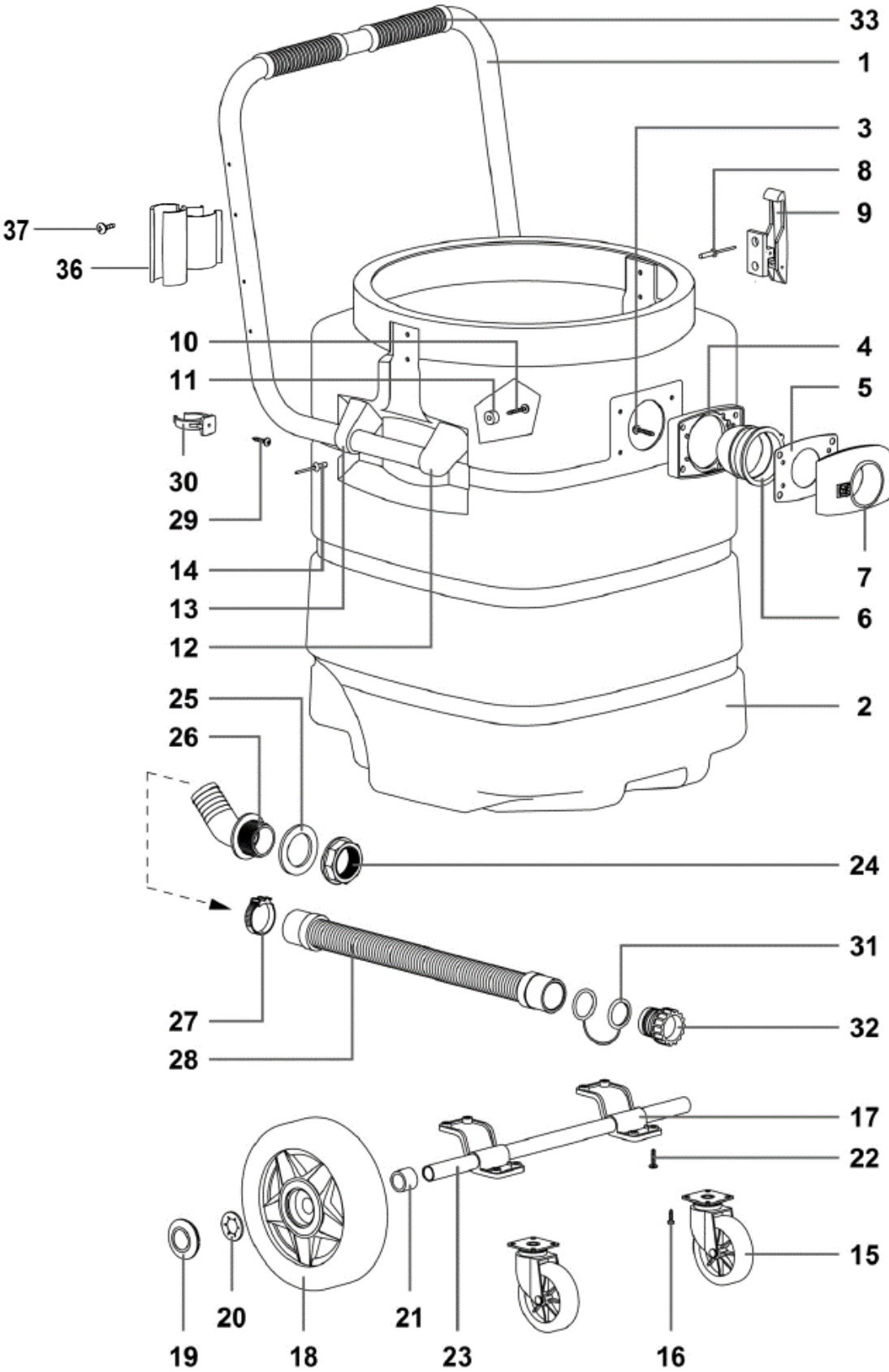

TANK ASSEMBLY

	Code	Part No.	Description	Qty
▽		KTRIO5771	TANK KIT, VACUUM [V-WD-24]	1
▲	1	N/A	HANDLE MARKET COMPACT BLACK	1
▲	2	N/A	TANK 400/SM NE C/SCA.DX FOR.	1
▲ ▽		KTRIO5656	FITTING KIT, HOSE, INLET	1
▲ ▲	3	1021640	SCREW PAT TMT PHL 5X30 BLACK	4
▲ ▲	4	N/A	GASKET 99 BLACK	1
▲ ▲	5	1021675	GASKET D.38	1
▲ ▲	6	1021685	DEFLECTOR 99	1
▲ ▲	7	N/A	PIPE UNION R155 NERO C/PUL.GI-VAC	1
▲ ▽		KTRIO5606	LATCH KIT, VACUUM [QTY 2]	1
▲ ▲	8	1021673	RIVET 5X24,5	4
▲ ▲	9	N/A	HOOK PLAST.COMPL. GI-VAC	2
▲	10	1021640	SCREW PAT TMT PHL 5X30 BLACK	8
▲	11	N/A	PLAST.WASHER	8
▲	12	N/A	HANDLE SUPPORT	2
▲	13	N/A	HANDLE SUPPORT PASSING	2
▲	14	N/A	RIVET 4,8X17 BLACK	2
▲	33	1021755	GRIP, TROLLEY HANDLE [QTY 2]	2
▲ ▽		KTRIO5657	CASTER KIT, VACUUM [QTY 2]	1
▲ ▲	15	1021754	FLANGED WHEEL D.80	2
▲ ▲	16	N/A	SCREW TC POZ 4X15 AC ZN BLACK	8
▲ ▽		KTRIO5728	AXLE KIT	1
▲ ▲	17	N/A	SUPPORT WHEEL PIN	2
▲ ▲	18	N/A	REAR WHEEL D.200	2
▲ ▲	19	1021750	PLUG [V14]	2
▲ ▲	20	N/A	BLOC. D.18	2
▲ ▲	21	N/A	WHEEL SPACER MARK.PLAST.	2
▲ ▲	22	1021628	SCREW [V10/V12/V14]	8
▲ ▲	23	N/A	PIVOT WHEEL MARK.PLAST.TANK	1
▲ ▽		KTRIO5659	FITTING KIT, DRAIN	1
▲ ▲	24	N/A	RING 1-1/4"	1
▲ ▲	25	N/A	GASKET 60X40X4	1
▲ ▲	26	N/A	FITTING CONNECTOR 45° 1-1/4"	1
▲ ▽		KTRIO5660	HOSE KIT, DRAIN , W/CAP	1
▲ ▲	27	N/A	CLIP 300X9	1
▲ ▲	28	N/A	DRAIN TUBE D.34 L=600	1
▲ ▲	31	N/A	TIE ROD CAP	1
▲ ▲	32	N/A	PLASTIC TOP D.40 X 35 W/OR COMPL.	1
▲ ▽		KTRIO5769	CLIP KIT, DRAIN HOSE	1
▲ ▲	29	N/A	SCREW PAT TMT PHL 5X20 INOX	1
▲ ▲	30	N/A	LIRA CLAMP D.34	1
▲ ▽		KTRIO2728	CLIP KIT, HANDLE, D.25	1
▲ ▲	36	N/A	CLIP D36-38 BLACK	2
▲ ▲	37	1021706	SCREW PAT TMT PHL 5X14 ZN BLACK	4
▲	NS	N/A	LABEL, MODEL [V-WD-24]	2
▲	NS	N/A	LABEL, WARNING, EN/FR/ES [AC W/D VAC]	1

▽ KIT

▲ INCLUDED IN KIT

N/A = NOT AVAILABLE SEPARATELY - MUST ORDER KIT

MAIN FILTER ASSEMBLY

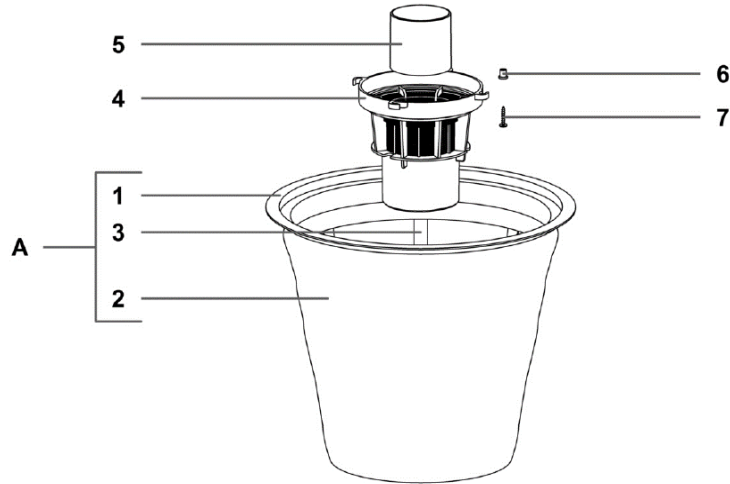

Code	Part No.	Description	QTY	
▽	A	KTRIO5840	FILTER KIT, VACUUM, MAIN	1
▲	1	1021730	FILTER RING 400	1
▲	2	N/A	FILTER POLY AN4-600 CON REG H320	1
▲	3	1021731	CONICAL BASKET 400	1
▽		KTRIO5850	FLOAT KIT, BASKET	1
▲	4	9008810	FILTER, VACUUM, ANTIFOAM	1
▲	5	1021666	FLOAT	1
▲	6	1021661	SPACER	4
▲	7	1021663	SCREW PAT TMT PHL 5X25	4
▽			KIT	
▲			INCLUDED IN KIT	
			N/A = NOT AVAILABLE SEPARATELY - MUST ORDER KIT	

VACUUM BAGS AND FILTERS

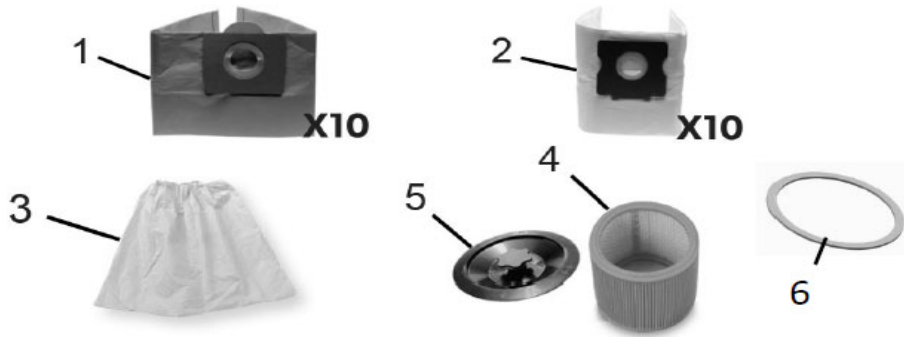

Code	Part No.	Description	Qty	
	1	KTRIO2912	BAG, VACUUM, PAPER [1 PKG = 10 BAGS]	1
	2	KTRIO5851	BAG, VACUUM, MICROFIBER [1 PKG=10 BAGS]	1
	3	KTRIO5846	FILTER, VACUUM, PRE-FILTER	1
▽		KTRIO5808	FILTER KIT, CARTRIDGE, HEPA W/RING & GASKET (OPTIONAL)	1
▲	4	KTRIO5801	FILTER, CARTRIDGE, HEPA	1
▲	5	KTRIO5839	RING, FASTENER, PLASTIC	1
▲	6	N/A	GASKET H3	1
▽			KIT	
▲			INCLUDED IN KIT	
			N/A = NOT AVAILABLE SEPARATELY - MUST ORDER KIT	

STANDARD ACCESSORY TOOLS

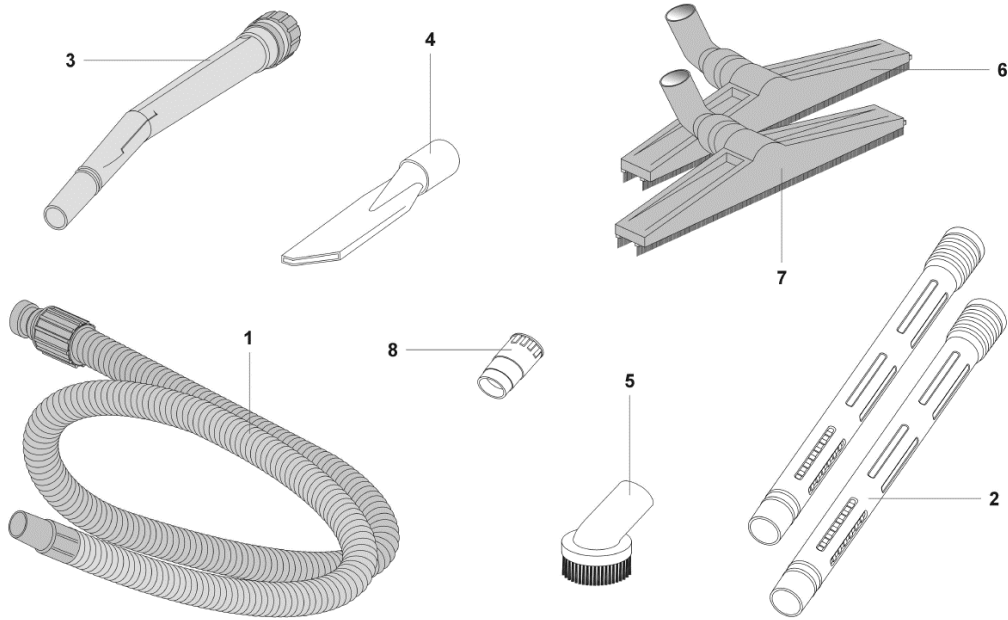

Code	Part No.	Description	QTY	
1	KTRIO5811	HOSE ASSY, VACUUM, 5M, 38 MM	1	
2	KTRIO5786	WAND SET, VACUUM, TWO-PIECE	2	
3	KTRIO5804	HANDLE, VACUUM HOSE W/ REG, 38 MM	1	
▽	KTRIO5608	TOOL KIT, VACUUM, Ø38 MM	1	
▲	4	1021757	FLAT LANCE D.38	1
▲	5	1021758	ROUND TOOL D.38 / small box	1
▲	8	1064521	PVC ADAPTOR D.38	1
6	1064519	TOOL, FLOOR, DRY, 38 MM	1	
7	1064520	TOOL, FLOOR, WET, 38 MM	1	
NS	KTRIO5821	TOOL, FLOOR, CARPET 38 MM (OPTIONAL)	1	

▽ KIT

▲ INCLUDED IN KIT

N/A = NOT AVAILABLE SEPARATELY - MUST ORDER KIT

OPTIONAL SQUEEGEE ATTACHMENT KIT

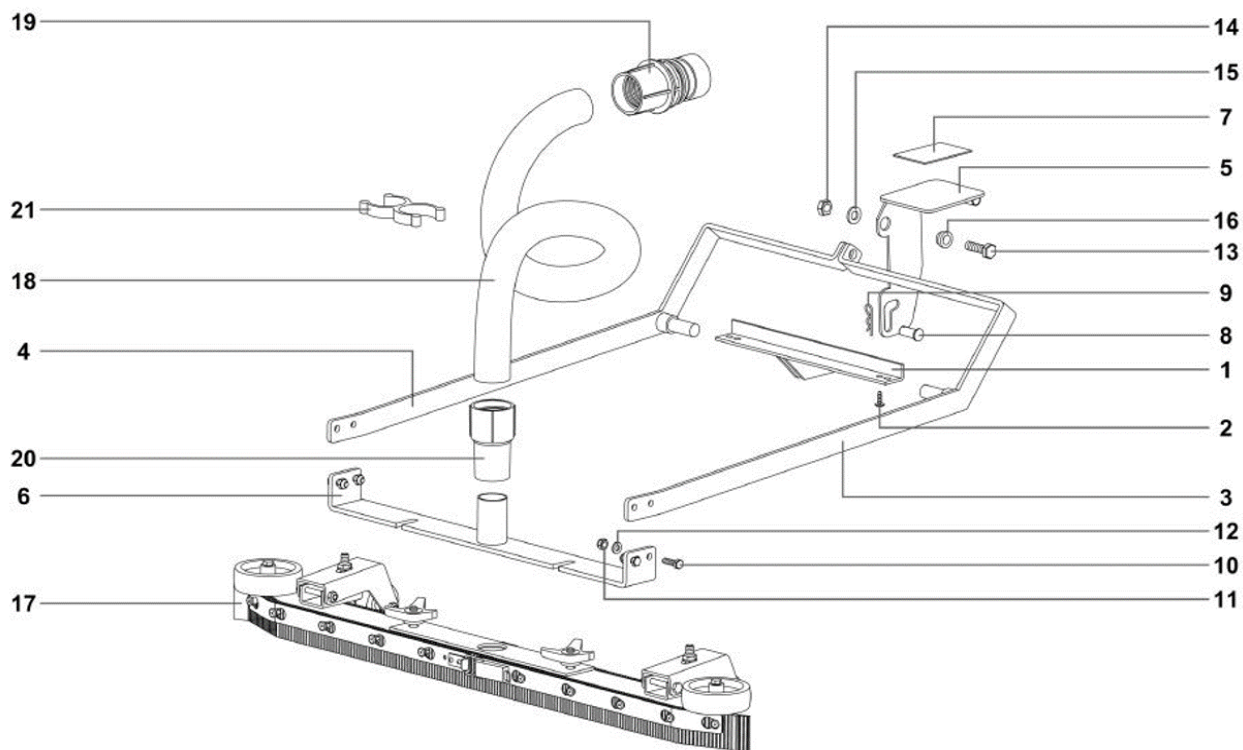

Code	Part No.	Description	Qty	
▽	KTRI05342	SQUEEGEE KIT, VACUUM, WITH BRACKET	1	
▲ ▽	KTRI05665	PEDAL KIT, SQGE	1	
▲ ▲ 1	N/A	SUPPORT PEDALE SQUEEGEE	1	
▲ ▲ 2	N/A	SCREW PAT TMT PHL 5X14 ZN BLACK	4	
▲ ▲ 5	N/A	PEDAL SQUEEGEE	1	
▲ ▲ 7	N/A	LABEL ADESIVA ANTISCIVOLO	1	
▲ ▲ 8	N/A	PIN DIA 10X30	1	
▲ ▲ 9	N/A	SPLIT PIN "R" D. 2 X 43 ZC	1	
▲ ▲ 13	N/A	SCREW TE M 10X30 UNI 5739	1	
▲ ▲ 14	N/A	SELF-LOCJ.NUT M10 SMALL UNI7474	1	
▲ ▲ 15	N/A	WASHER M 10	1	
▲ ▲ 16	N/A	SPACER SQUEEGEE 18X14X10	1	
▲ ▽	KTRI05666	BRACKET KIT, SQGE	1	
▲ ▲ 3	N/A	SHEET METAL PA. DX SISTEMA SOLLEVAMENTO	1	
▲ ▲ 4	N/A	SHEET METAL PA. SX SISTEMA SOLLEVAMENTO	1	
▲ ▲ 6	N/A	PLATE ANTERIORE SISTEMA SOLLEVA	1	
▲ ▲ 10	N/A	SCREW TE M 6X20 INOX UNI 5739	4	
▲ ▲ 11	N/A	SELFLOCKING NUT M 5 HIGH DIN 982	4	
▲ ▲ 12	N/A	STEEL WASHER M6	4	
▲ ▽	KTRI05667	HOSE KIT, SQUEEGEE	1	
▲ ▲ 18	N/A	FLEXIBLE HOSE 32 NERO MT.1 TYPE 3	1	
▲ ▲ 19	N/A	SLEEVE D.38/32 T.FLEX D.32 C/OR	1	
▲ ▲ 20	N/A	CUFF FOR "Y" CONNECTOR	1	
▲ ▲ 21	N/A	CLIP SIFONE TUBOFLEX 36	1	
▲	17	KTRI05812	SQUEEGEE KIT, VACUUM, 75CM	1
▲	NS	N/A	DOUBLE SCREWDRIVER	1

▽ KIT

▲ INCLUDED IN KIT

N/A = NOT AVAILABLE SEPARATELY - MUST ORDER KIT

OPTIONAL SQUEEGEE ASSEMBLY

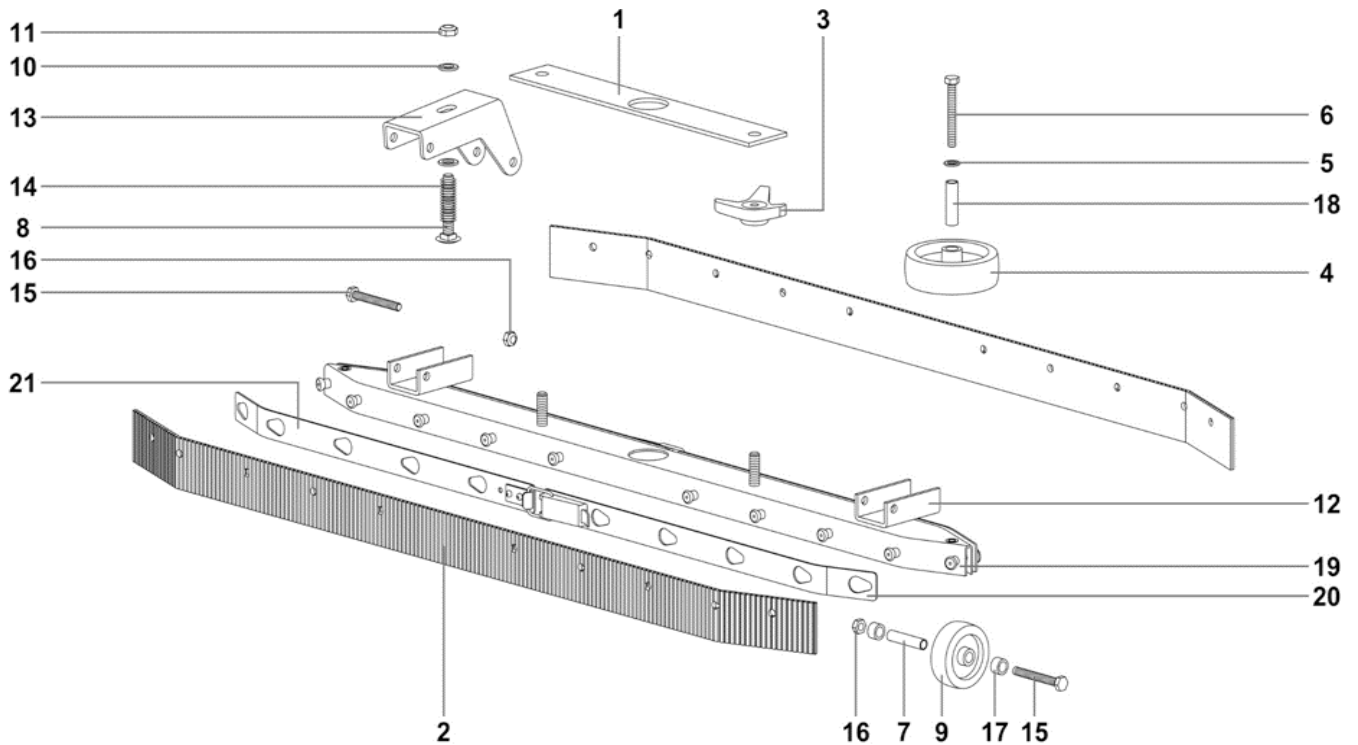

Code	Part No.	Description	Qty	
▽	KTRIO5812	SQUEEGEE KIT, VACUUM, 75CM	1	
▲	1	N/A	1	
▲	2	KTRIO5783	BLADE SET, SQGE	2
▲	3	KTRIO5784	KNOB SET, SQGE, YELLOW	2
▲ ▽	KTRIO5714	WHEEL KIT, SQGE, WALL ROLLER	1	
▲ ▲	4	N/A	2	
▲ ▲	5	N/A	2	
▲ ▲	6	N/A	2	
▲ ▲	18	N/A	2	
▲ ▽	KTRIO5715	WHEEL KIT, SQGE, FLOOR SUPPORT	2	
▲ ▲	7	N/A	2	
▲ ▲	8	N/A	2	
▲ ▲	9	N/A	2	
▲ ▲	10	N/A	4	
▲ ▲	11	N/A	2	
▲ ▲	12	N/A	2	
▲ ▲	13	N/A	2	
▲ ▲	14	N/A	2	
▲ ▲	15	N/A	4	
▲ ▲	16	N/A	4	
▲ ▲	17	N/A	4	
▲	19	N/A	1	
▲ ▽	KTRIO5716	CLAMP KIT, SQGE	1	
▲ ▲	20	N/A	2	
▲ ▲	21	N/A	2	

▽ KIT

▲ INCLUDED IN KIT

N/A = NOT AVAILABLE SEPARATELY - MUST ORDER KIT

LABEL KIT

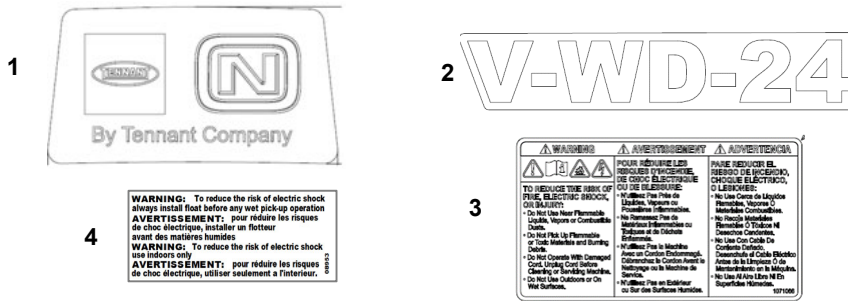

Code	Part No.	Description	QTY
▽	KTRI05852	LABEL KIT,VACUUM [V-WD-24]	1
▲	1	N/A LABEL, LOGO, DUAL [TENNANT/NOBLES]	1
▲	2	N/A LABEL, MODEL [V-WD-24]	2
▲	3	N/A LABEL, WARNING, EN/FR/ES	1
▲	4	N/A LABEL, WARNING, UL	1

▽ KIT

▲ INCLUDED IN KIT

N/A = NOT AVAILABLE SEPARATELY - MUST ORDER KIT

ELECTRICAL DIAGRAM

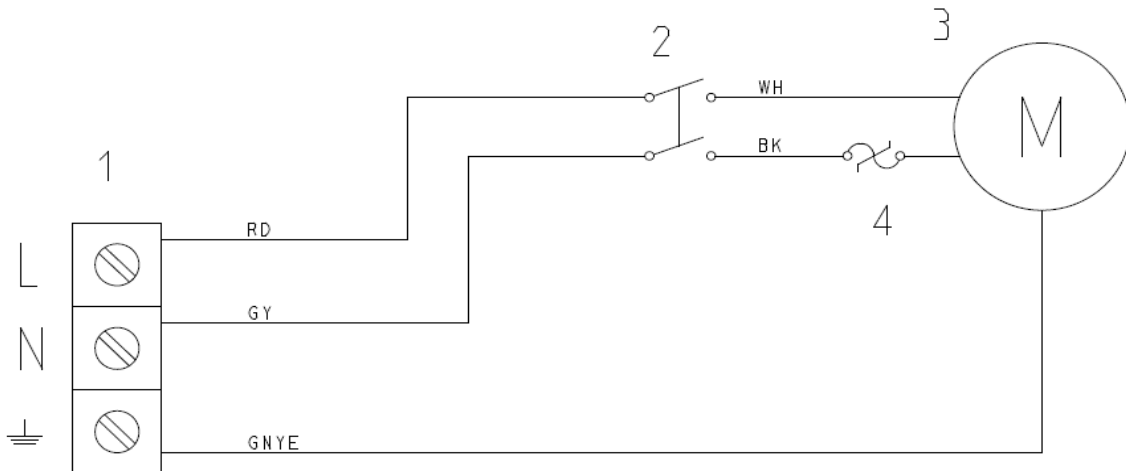

n°	Component description
1	Mains terminal block
2	Motor switch
3	Motor
4	Thermal amperometric motor protector