



## **Electronic Service Manuals**

This electronic document is provided as a service to our customers. We do not create the contents of the information contained in this document. Should you have detailed questions pertaining to the information contained in this document, you may contact Michco, or the manufacturer which provided the original information in this electronic deliverable. Michco's only part in this electronic deliverable was the electronic assembly process. By providing this manual online we are not guaranteeing parts availability.

You may contact Michco through the following methods:

**Phone (517) 484-9312**

2011 N. High St. -- Lansing, Michigan -- 48906

Fax: (517) 484-9836

Email: [CustomerService@Michco.com](mailto:CustomerService@Michco.com)

Website: [www.Michco.Com](http://www.Michco.Com)

Order Parts online at:

**[www.Michco.Com](http://www.Michco.Com)**

Directly to Parts & Service:

By Email: **[CustomerService@Michco.com](mailto:CustomerService@Michco.com)**

By Fax: (517) 484-9836

By Voice: (517) 484-9312

**Serving the Cleaning Industry Since 1922**

Notice: All copyrighted material remains property of original owners, all trademarks are property of respective owners. Manuals are subject to Manufacturer's reproduction limitations. Originals or reproductions were provided by manufacturers through a request. We make no warranty as to the correctness of information provided in this document and you assume all risk. By placing these manuals on line we are not declaring our corporation to be an manufacturer authorized dealer or provider, please check our web site for authorized manufacturers we represent.



# V-CAN-16

Canister Dry Vacuum Cleaner

Parts Manual

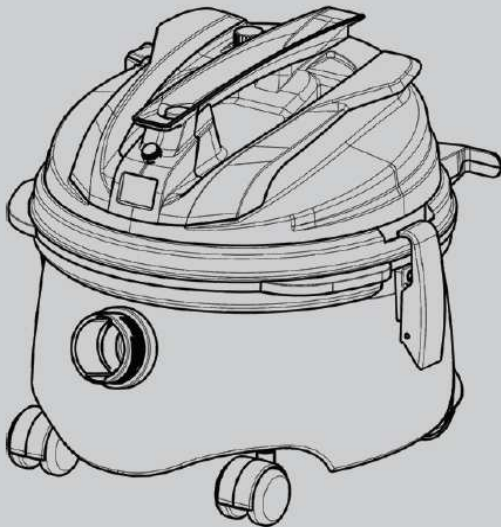

Model Part No.:

1244321 V-CAN-16 [120V NA]  
1244323 V-CAN-16 [220-240V EU]  
1244324 V-CAN-16 [220-240V UK]  
1244329 V-CAN-16 [220-240V ANZ]  
1244326 V-CAN-16 [220-240V CN]  
1244328 V-CAN-16 [100V JP]

**TennantTrue® Parts**

**Global**



To view, print or download the parts manual, visit:

[www.tennantco.com/manuals](http://www.tennantco.com/manuals)

9018761  
Rev. 00 (03-2019)

Only use TENNANT Company supplied or equivalent parts.  
Parts and supplies may be ordered online, by phone or from any Tennant or Nobles  
Authorized Service Center or Distributor.

Before Ordering any parts or supplies, be sure to have the machine model number and  
serial number available.

**Tennant Company**

PO Box 1452  
Minneapolis, MN 55440 USA  
Phone: (800) 553-8033  
[www.tennantco.com](http://www.tennantco.com)

**Tennant Company N.V.**

Industrielaan 6 5405 AB  
P.O. Box 6 5400 AA  
Uden- The Netherlands  
[europa@tennantco.com](mailto:europa@tennantco.com)  
[www.tennantco.com](http://www.tennantco.com)

**TENNANT Cleaning Systems &  
Equipment (Shanghai) Co., Ltd**

Building 1, No. 3777 Caoying Road  
Qingpu Shanghai, China 201712  
Phone: 86 21 6922 5333  
Fax: 86 21 69225151  
[www.tennant.co.cn](http://www.tennant.co.cn)

**TENNANT Company Japan**

9F Industry & Trade Center  
2 Yamashita- cho, Naka- ku  
Yokohama, Kanagawa 231- 0023  
Japan  
Phone: 81-45-640-5630  
Fax: 81-45-640-5604  
[www.tennant.co.jp](http://www.tennant.co.jp)

Specifications and parts are subject to change without notice.  
Copyright ©2019 TENNANT Company

# TABLE OF CONTENTS

HEAD ASSEMBLY (NA 120V MODEL).....	4
HEAD ASSEMBLY (EU/UK/ANZ 220-240V MODELS).....	6
HEAD ASSEMBLY (CHINA 220-240V MODEL).....	8
HEAD ASSEMBLY (JAPAN 100V MODEL).....	10
TANK ASSEMBLY.....	12
VACUUM BAGS & MAIN FILTER ASSEMBLY.....	12
ACCESSORY TOOLS.....	13
LABEL KIT.....	13
ELECTRICAL DIAGRAM.....	14

## RECOMMENDED SPARE PARTS LIST

VACUUM BAGS AND FILTERS	
9018690	BAG, VACUUM, PAPER [1 PKG = 10 BAGS]
9018692	BAG, VACUUM, MICROFIBER [1 PKG=10 BAGS]
KTRIO5904	FILTER, HEPA CARTRIDGE, EXHAUST [STANDARD]
KTRIO5903	FILTER, EXHAUST [OPTIONAL]
KRTIO5920	FILTER, POLYCARBONATE, MAIN
KRTIO5919	SUPPORT, FILTER BASKET
CLEANING TOOL ACCESSORIES	
KTRIO5905	HOSE ASSY, VACUUM, 2.5M [32MM]
KTRIO5921	WAND, CHROME, TELESCOPIC [32MM]
KTRIO5906	HANDLE, VACUUM HOSE W/ REG [32MM]
KTRIO5936	TOOL, FLOOR, DRY, DOUBLE USE [32MM]
KTRIO5794	TOOL KIT, VACUUM [32MM]
KTRIO5942	TOOL HOLDER - OPTIONAL
GENERAL MAINTENANCE PARTS	
KTRIO5834	CASTER KIT, VACUUM [QTY 2]
KTRIO5795	LATCH KIT, VACUUM [QTY 2]
KTRIO5908	SWITCH, ON/OFF
KTRIO5909	CORD, POWER, 120V [NA]
KTRIO5910	CORD, POWER, 220-240V [EU]
KTRIO5911	CORD, POWER, 220-240V [UK]
KTRIO5912	CORD, POWER, 220-240V [ANZ]
KTRIO5797	CORD KIT, POWER, 220-240V [CN]
KTRIO5796	CORD KIT, POWER, 100V [JP]
KTRIO5913	MOTOR KIT, VACUUM, 800W, 120V/60HZ [NA]
KTRIO5922	MOTOR KIT, VACUUM, 650W, 220-240V
KTRIO5914	MOTOR KIT, VACUUM, 800W, 100V [JP]
KTRIO5875	GASKET KIT, MOTOR
KTRIO5916	COVER, FILTER, EXHAUST [V-CAN-12/16 NA]
KTRIO5918	COVER, FILTER, EXHAUST [V-CAN-12/16 EMEA/APAC]

# HEAD ASSEMBLY (NA 120V MODEL)

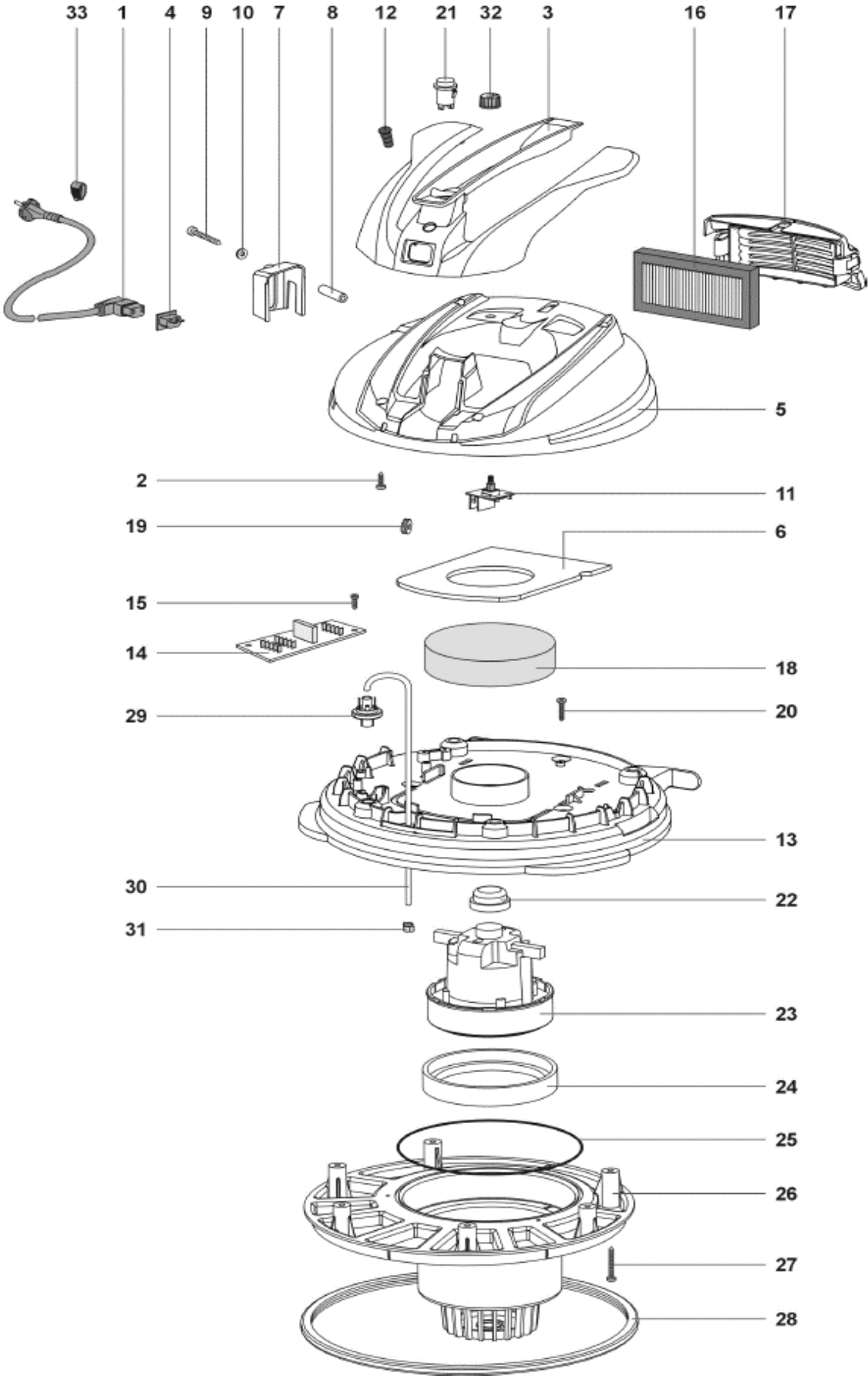

# HEAD ASSEMBLY (NA 120V MODEL)

Code	Part No.	Description	QTY
▽	KTRIO5877	HOUSING ASSY, POWER, HEAD [V-CAN-16 NA]	1
▲ ▽	KTRIO5879	COVER KIT, VACUUM [V-CAN-16 NA]	1
▲ ▲ 1	KTRIO5909	CORD, POWER, 120 [NA]	1
▲ ▲ 2	1021706	SCREW PAT TMT PHL 5X14 ZN BLACK	4
▲ ▲ 3	N/A	HANDLE TENNANT DRY GR.55 S/L	1
▲ ▲ 5	N/A	COVER TENNANT DRY BLU TEN AU C/	1
▲ ▲ 6	N/A	GASKET ADESIVA COP. TEN DRY PE	1
▲ ▲ 4	99932858	PLUG, MACH, 120V-230V	1
▲ ▲ ▽	KTRIO5789	COVER KIT, CORD RETAINER, [V-CAN-16 NA]	1
▲ ▲ ▲ 7	N/A	COVER BL.CAVO TENNANT DRY BLT A	1
▲ ▲ ▲ 8	N/A	SPACER BLOCCA CAVO V-CAN BTEN AU	1
▲ ▲ ▲ 9	1021643	SCREW PAT TMT PHL 5X50	1
▲ ▲ ▲ 10	N/A	WASHER M 6 UNI 6592	1
▲ ▲ ▽	KTRIO5881	REGULATOR KIT, SPEED 120V	1
▲ ▲ ▲ 11	N/A	POTENTIOMETER 110-115V LEGNANI	1
▲ ▲ ▲ 32	N/A	KNOB POTENTIOMETER BLACK COMP	1
▲ ▲ ▲ N/S	N/A	WIRE, POT. GREY	2
▲ ▲ ▽	KTRIO5882	LIGHT KIT, BAG FULL	1
▲ ▲ ▲ 12	N/A	LAMP W/RED GEM W/RING NUT	1
▲ ▲ ▲ N/S	N/A	WIRE, LAMP	1
▲ ▲ 16	KTRIO5904	FILTER, HEPA CARTRIDGE	1
▲ ▲ 17	KTRIO5916	COVER, FILTER, EXHAUST [V-CAN-12/16]	1
▲ ▲ 19	N/A	GUIDING SLIT W/LEO MEMBRANE	1
▲ ▲ 21	KTRIO5908	SWITCH	1
▲ ▲ ▽	KTRIO5883	WIRE KIT, SWITCH [NA]	1
▲ ▲ ▲ N/S	N/A	WIRE , RED	2
▲ ▲ N/S	1059271	WIRING 43CM MOTOR	1
▲ ▲ N/S	N/A	FASTON COVER FOR ART.01103/C	4
▲ 13	N/A	MOTOR FASTENER YVO DRY GR.55 AU	1
▲ 14	KTRIO5933	CONTROL BOARD	1
▲ 15	1021706	SCREW PAT TMT PHL 5X14 ZN BLACK	2
▲ 18	KTRIO5931	FILTER, FOAM	1
▲ 20	1021628	SCREW PFU TMT PHL 5X20 BLACK	3
▲ 23	KTRIO5913	MOTOR, 800W 120V 60HZ	1
▲ N/S	N/A	CLAMP	5
▲ ▽	KTRIO5875	GASKET KIT, MOTOR	1
▲ ▲ 22	N/A	MOT.FASTENER GUM G.EPDM30 D42X20	1
▲ ▲ 24	N/A	L-GASKET D.130 H=9	1
▲ ▲ 25	N/A	O-RING GOMMA SPUGNA D.4 D.190	1
▲ 26	N/A	LEO BASE AU BL	1
▲ 27	1021640	SCREW PAT TMT PHL 5X30 BLACK	6
▲ 28	KTRIO5932	GASKET, HEAD ASSEMBLY	1
▲ ▽	KTRIO5901	SWITCH KIT, PRESSURE SENSITIVE [NA]	1
▲ ▲ 29	N/A	PRESSURE SENS. 140 MBAR	1
▲ ▲ 30	N/A	TUBE PVC D.5X3 CM46 X WAR LIGH	1
▲ ▲ 31	N/A	CABLE TIE D.5 MONO LOBO	1
▲ ▲ N/S	N/A	WIRE, PRESS SENS, GREY	2
▲ 33	N/A	CLIP BIG FIXING CABL ELE	1
▲ N/S	N/A	LABEL, VAC SPEED	1

▽ KIT

▲ INCLUDED IN KIT

N/A = NOT AVAILABLE SEPARATELY - MUST ORDER KIT

# HEAD ASSEMBLY (EU/UK/ANZ 220-240V MODELS)

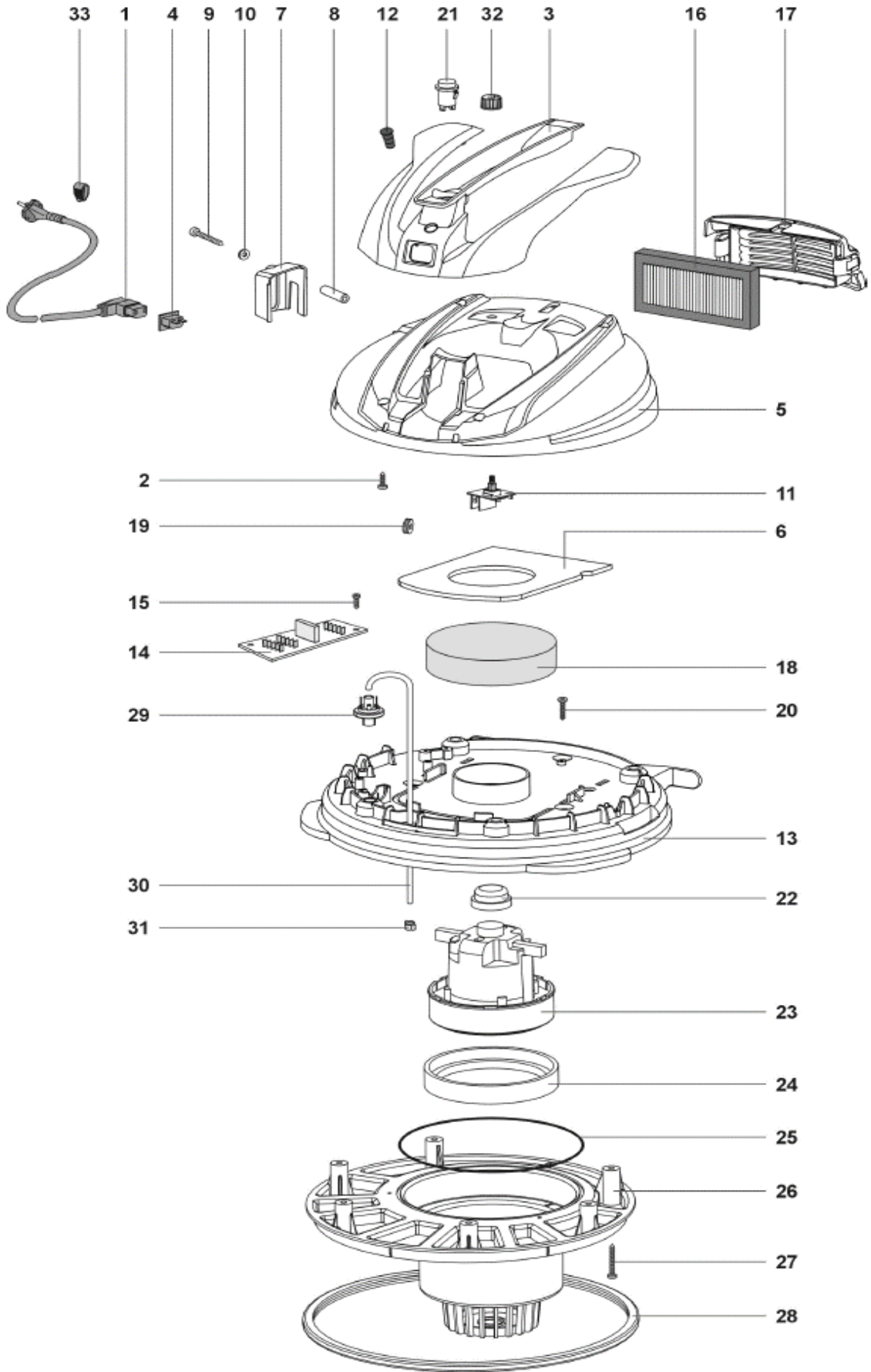

## HEAD ASSEMBLY (EU/UK/ANZ 220-240V MODELS)

Code	Part No.	Description	QTY
▽	KTRI05870	HOUSING ASSY, POWER,[V-CAN-16 EU UK ANZ]	1
▲ ▽	KTRI05871	COVER KIT, VACUUM [V-CAN-16 EU UK ANZ]	1
▲ 1	KTRI05910	CORD, POWER, 220-240V [EU]	1
▲ 1	KTRI05911	CORD, POWER, 220-240V [UK]	1
▲ 1	KTRI05912	CORD, POWER, 220-240V [ANZ]	1
▲ ▲ 2	1021706	SCREW PAT TMT PHL 5X14 ZN BLACK	4
▲ ▲ 3	N/A	HANDLE	1
▲ ▲ 5	N/A	COVER	1
▲ ▲ 6	N/A	GASKET ADESIVA COP. TEN DRY PE	1
▲ ▲ 4	99932858	PLUG, MACH, 120V-230V	1
▲ ▲ ▽	KTRI05788	COVER KIT, CORD RETAINER	1
▲ ▲ ▲ 7	N/A	COVER BL.CAVO TENNANT DRY BLU T	1
▲ ▲ ▲ 8	N/A	SPACER PLASTIC D.10 D.6,3X20	1
▲ ▲ ▲ 9	1021643	SCREW PAT TMT PHL 5X50	1
▲ ▲ ▲ 10	N/A	WASHER M 6 UNI 6592	1
▲ ▲ ▽	KTRI05872	REGULATOR KIT, SPEED 220-240V	1
▲ ▲ ▲ 11	N/A	POTENTIOMETER 220-240V	1
▲ ▲ ▲ 32	N/A	KNOB POTENTIOMETER BLACK COMP	1
▲ ▲ ▲ N/S	N/A	WIRE, POT. BLUE	2
▲ ▲ ▽	KTRI05873	LIGHT KIT, BAG FULL	1
▲ ▲ ▲ 12	N/A	LAMP W/RED GEM W/RING NUT	1
▲ ▲ ▲ N/S	N/A	WIRE, LAMP	1
▲ ▲ 16	KTRI05904	FILTER, HEPA CARTRIDGE	1
▲ ▲ 17	KTRI05918	COVER, FILTER, EXHAUST [V-CAN-16 EU]	1
▲ ▲ 19	N/A	GUIDING SLIT W/LEO MEMBRANE	1
▲ ▲ 21	KTRI05908	SWITCH	1
▲ ▲ ▽	KTRI05874	WIRE KIT, SWITCH	1
▲ ▲ ▲ N/S	N/A	WIRE, RED	2
▲ ▲ ▲ N/S	N/A	WIRE , GRAY	2
▲ ▲ N/S	1059271	WIRING 43CM MOTOR	1
▲ ▲ N/S	N/A	WIRING DOLPHIN LUXE UL	1
▲ ▲ N/S	N/A	FASTON COVER FOR ART.01103/C	4
▲ 13	N/A	MOTOR FASTENER YVO DRY GR.55	1
▲ 14	KTRI05933	CONTROL BOARD	1
▲ 15	1021706	SCREW PAT TMT PHL 5X14 ZN BLACK	2
▲ 18	KTRI05931	FILTER, FOAM	1
▲ 20	1021628	SCREW PFU TMT PHL 5X20 BLACK	3
▲ 23	KTRI05922	MOTOR, 650W, 220-240VAC [V-CAN-16]	1
▲ N/S	N/A	CLAMP	5
▲ ▽	KTRI05875	GASKET KIT, MOTOR	1
▲ ▲ 22	N/A	MOT.FASTENER GUM G.EPDM30 D42X20	1
▲ ▲ 24	N/A	L-GASKET D.130 H=9	1
▲ ▲ 25	N/A	O-RING GOMMA SPUGNA D.4 D.190	1
▲ 26	N/A	LEO BASE	1
▲ 27	1021640	SCREW PAT TMT PHL 5X30 BLACK	6
▲ 28	KTRI05932	GASKET, HEADY ASSEMBLY	1
▲ ▽	KTRI05876	SWITCH KIT, PRESSURE SENSITIVE	1
▲ ▲ 29	N/A	PRESSURE SENS. 140 MBAR	1
▲ ▲ 30	N/A	TUBE PVC D.5X3 CM46 X WAR LIGH	1
▲ ▲ 31	N/A	CABLE TIE D.5 MONO LOBO	1
▲ 33	N/A	CLIP BIG FIXING CABL ELE	1
▲ N/S	N/A	LABEL, VAC SPEED [V-CAN-16]	1

▽ KIT

▲ INCLUDED IN KIT

N/A = NOT AVAILABLE SEPARATELY - MUST ORDER KIT

# HEAD ASSEMBLY (CHINA 220-240V MODEL)

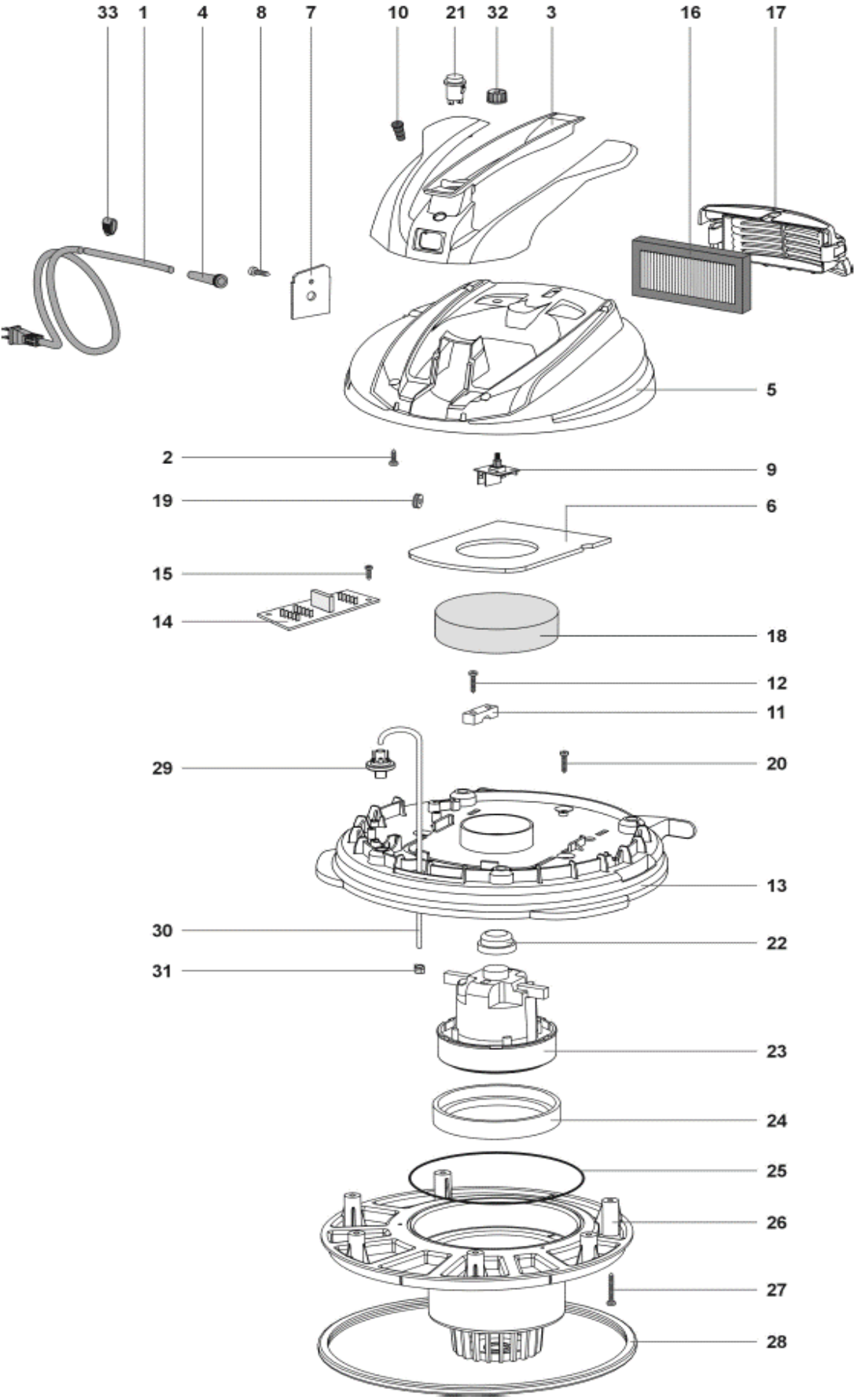

# HEAD ASSEMBLY (CHINA 220-240V MODEL)

Code	Part No.	Description	QTY
▽	KTRIO5885	HOUSING ASSY, POWER, HEAD [V-CAN-16 CN]	1
▲ ▽	KTRIO5887	COVER KIT, VACUUM [V-CAN-16 CN]	1
▲ ▲ 2	1021706	SCREW PAT TMT PHL 5X14 ZN BLACK	4
▲ ▲ 3	N/A	HANDLE	1
▲ ▲ 5	N/A	COVER	1
▲ ▲ 6	N/A	GASKET ADESIVA COP. TEN DRY PE	1
▲ ▲ ▽	KTRIO5797	POWER CORD KIT, 220-240V [CN]	1
▲ ▲ ▲ 1	N/A	CABLE ELETTRICO 2X0,75 MT.8,5 F [CN]	1
▲ ▲ ▲ 4	1021625	LEAD	1
▲ ▲ ▲ 7	N/A	COVER BL.CAVO TENNANT DRY BLU T	1
▲ ▲ ▲ 8	1021628	SCREW PFU TMT PHL 5X20 BLACK	1
▲ ▲ ▲ 11	1021626	CABLE CLAMP	1
▲ ▲ ▲ 12	1021628	SCREW PFU TMT PHL 5X20 BLACK	2
▲ ▲ ▲ 33	N/A	CLIP BIG FIXING CABL ELE	1
▲ ▲ ▽	KTRIO5872	REGULATOR KIT, SPEED 220V [V-CAN-16 CN]	1
▲ ▲ ▲ 9	N/A	POTENTIOMETER 220-240V	1
▲ ▲ ▲ 32	N/A	KNOB POTENTIOMETER BLACK COMP	1
▲ ▲ ▲ N/S	N/A	WIRE, POT. BLUE	1
▲ ▲ ▽	KTRIO5873	LIGHT KIT, BAG FULL	1
▲ ▲ ▲ 10	N/A	LAMP W/RED GEM W/RING NUT	1
▲ ▲ ▲ N/S	N/A	WIRE, LAMP	1
▲ ▲ 16	KTRIO5904	FILTER, HEPA CARTRIDGE	1
▲ ▲ 17	KTRIO5918	COVER, FILTER EXHAUST [V-CAN-16 EU/APAC]	1
▲ ▲ 19	N/A	GUIDING SLIT W/LEO MEMBRANE	1
▲ ▲ 21	KTRIO5908	SWITCH	1
▲ ▲ N/S	1059271	WIRING 43CM MOTOR	1
▲ ▲ N/S	N/A	WIRING DOLPHIN LUXE UL	1
▲ ▲ N/S	N/A	FASTON COVER FOR ART.01103/C	4
▲ 13	N/A	MOTOR FASTENER YVO DRY GR.55	1
▲ 14	KTRIO5933		1
▲ 15	1021706	SCREW PAT TMT PHL 5X14 ZN BLACK	2
▲ 18	KTRIO5931	FILTER, FOAM	1
▲ 20	1021628	SCREW PFU TMT PHL 5X20 BLACK	3
▲ 23	KTRIO5922	MOTOR, 650W, 220-240VAC [V-CAN-16]	1
▲ N/S	N/A	CLAMP	5
▲ ▽	KTRIO5875	GASKET KIT, MOTOR	1
▲ ▲ 22	N/A	MOT.FASTENER GUM G.EPDM30 D42X20	1
▲ ▲ 24	N/A	L-GASKET D.130 H=9	1
▲ ▲ 25	N/A	O-RING GOMMA SPUGNA D.4 D.190	1
▲ 26	N/A	LEO BASE	1
▲ 27	1021640	SCREW PAT TMT PHL 5X30 BLACK	6
▲ 28	KTRIO5932	GASKET, HEAD ASSEMBLY	1
▲ ▽	KTRIO5876	SWITCH KIT, PRESSURE SENSITIVE	1
▲ ▲ 29	N/A	PRESSURE SENS. 140 MBAR	1
▲ ▲ 30	N/A	TUBE PVC D.5X3 CM46 X WAR LIGH	1
▲ ▲ 31	N/A	CABLE TIE D.5 MONO LOBO	1
▲ ▲ N/S	N/A	WIRE, PRESS SENS, BLUE	2
▲ N/S	N/A	LABEL, VAC SPEED [V-CAN-16]	1

▽ KIT

▲ INCLUDED IN KIT

N/A = NOT AVAILABLE SEPARATELY - MUST ORDER KIT

# HEAD ASSEMBLY (JAPAN 100V MODEL)

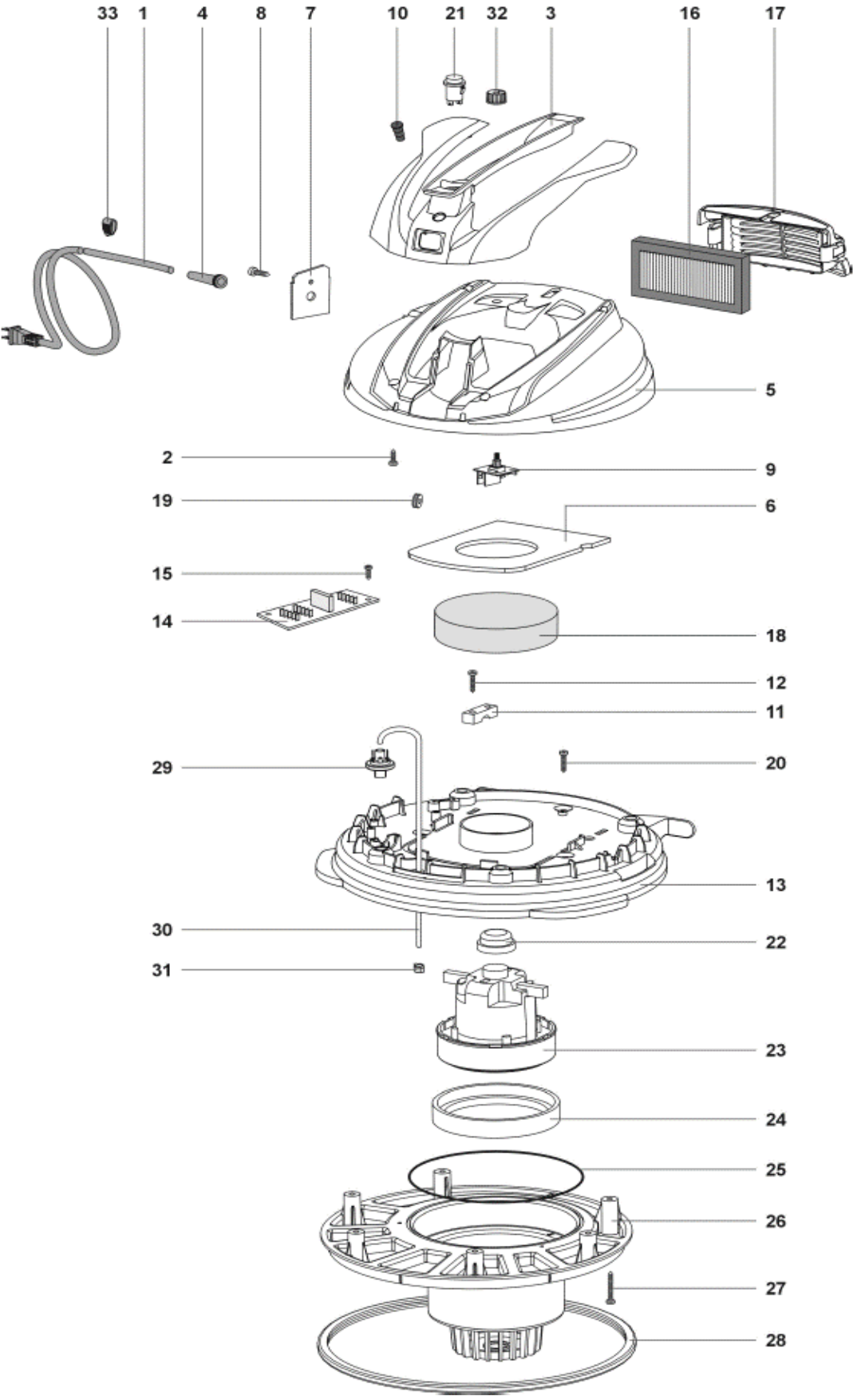

# HEAD ASSEMBLY (JAPAN 100V MODEL)

Code	Part No.	Description	QTY
▽	KTRIO5884	HOUSING ASSY, POWER, HEAD [V-CAN-16 JP]	1
▲ ▽	KTRIO5886	COVER KIT, VACUUM [V-CAN-16 JP]	1
▲ ▲	2 1021706	SCREW PAT TMT PHL 5X14 ZN BLACK	4
▲ ▲	3 N/A	COVERING BOSTON BY PASS BLACK	1
▲ ▲	5 N/A	COVERING BOSTON BY PASS BLACK	1
▲ ▲	6 N/A	GASKET ADESIVA COP. TEN DRY PE	1
▲ ▲ ▽	KTRIO5796	POWER CORD KIT, 100V [JP]	1
▲ ▲ ▲	1 N/A	CABLE E. 2X1 MT12 GI IEC320 [JP]	1
▲ ▲ ▲	4 1021625	LEAD	1
▲ ▲ ▲	7 N/A	COVER BL.CAVO TENNANT DRY BLU T	1
▲ ▲ ▲	8 1021628	SCREW PFU TMT PHL 5X20 BLACK	1
▲ ▲ ▲	11 1021626	CABLE CLAMP	1
▲ ▲ ▲	12 1021628	SCREW PFU TMT PHL 5X20 BLACK	2
▲ ▲ ▲	33 N/A	CLIP BIG FIXING CABL ELE	1
▲ ▲ ▽	KTRIO5888	REGULATOR KIT, SPEED 100V [V-CAN-16 JP]	1
▲ ▲ ▲	9 N/A	POTENTIOMETER 100V 50/60	1
▲ ▲ ▲	32 N/A	KNOB POTENTIOMETER BLACK COMP	1
▲ ▲ ▲	N/S N/A	WIRE, POT. BLUE	1
▲ ▲ ▽	KTRIO5882	LIGHT KIT, BAG FULL	1
▲ ▲ ▲	10 N/A	LAMP W/RED GEM W/RING NUT	1
▲ ▲ ▲	N/S N/A	WIRE, LAMP	1
▲ ▲	16 KTRIO5904	FILTER, HEPA CARTRIDGE	1
▲ ▲	17 KTRIO5918	COVER, FILTER EXHAUST [V-CAN-16 EU/APAC]	1
▲ ▲	19 N/A	GUIDING SLIT W/LEO MEMBRANE	1
▲ ▲	21 KTRIO5908	SWITCH	1
▲ ▲ ▽	KTRIO5941	WIRE KIT, SWITCH [JP]	1
▲ ▲ ▲	N/S N/A	WIRE , GRAY	2
▲ ▲	N/S 1059271	WIRING 43CM MOTOR	1
▲ ▲	N/S N/A	WIRING DOLPHIN LUXE UL	1
▲ ▲	N/S N/A	FASTON COVER FOR ART.01103/C	4
▲	13 N/A	MOTOR FASTENER YVO DRY GR.55	1
▲	14 KTRIO5933		1
▲	15 1021706	SCREW PAT TMT PHL 5X14 ZN BLACK	2
▲	18 KTRIO5931	FILTER, FOAM	1
▲	20 1021628	SCREW PFU TMT PHL 5X20 BLACK	3
▲	23 KTRIO5914	MOTOR, 800W, 100V 50/60HZ [JP]	1
▲	N/S N/A	CLAMP	5
▲ ▽	KTRIO5875	GASKET KIT, MOTOR	1
▲ ▲	22 N/A	MOT.FASTENER GUM G.EPDM30 D42X20	1
▲ ▲	24 N/A	L-GASKET D.130 H=9	1
▲ ▲	25 N/A	O-RING GOMMA SPUGNA D.4 D.190	1
▲	26 N/A	LEO BASE	1
▲	27 1021640	SCREW PAT TMT PHL 5X30 BLACK	6
▲	28 KTRIO5932	GASKET, HEAD ASSEMBLY	1
▲ ▽	KTRIO5876	SWITCH KIT, PRESSURE SENSITIVE	1
▲ ▲	29 N/A	PRESSURE SENS. 140 MBAR	1
▲ ▲	30 N/A	TUBE PVC D.5X3 CM46 X WAR LIGH	1
▲ ▲	31 N/A	CABLE TIE D.5 MONO LOBO	1
▲ ▲	N/S N/A	WIRE, PRESS SENS, BLUE	2
▲	N/S N/A	LABEL, VAC SPEED [V-CAN-16]	1

▽ KIT

▲ INCLUDED IN KIT

N/A = NOT AVAILABLE SEPARATELY - MUST ORDER KIT

# TANK ASSEMBLY

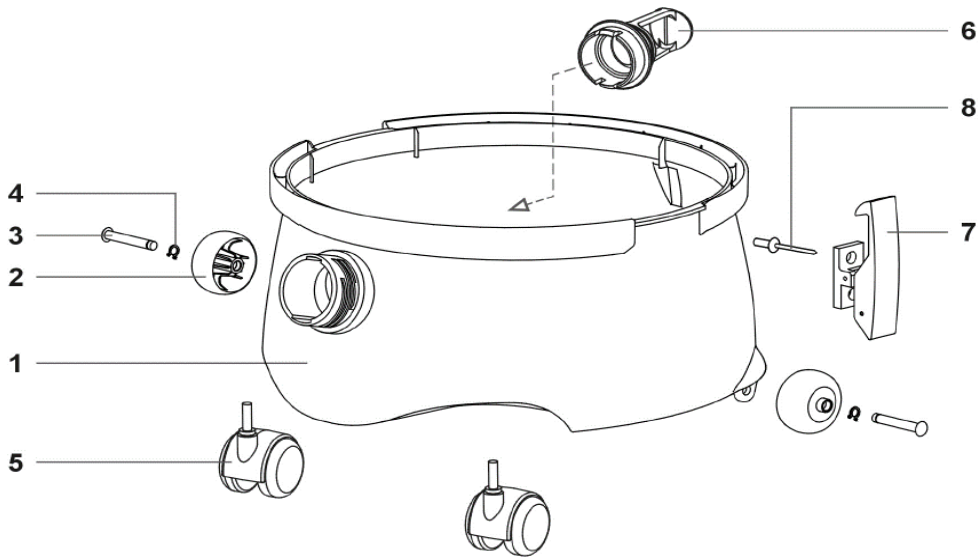

Code	Part No.	Description	QTY
▽	KTRIO5890	TANK KIT, VACUUM w/ LABELS [V-CAN-16 NA]	1
▽	KTRIO5889	TANK KIT, VACUUM w/ LABELS [V-CAN-16 EU/APAC]	1
▲ 1	N/A	TANK LEO BL FORATO X HOOKS 210	1
▲ ▽	KTRIO5892	WHEEL KIT [QTY 2]	1
▲ ▲ 2	N/A	WHEEL POST.LEO MAXI BIMATERIAL	2
▲ ▲ 3	N/A	WHEEL PIN LEO MX.	2
▲ ▲ 4	N/A	CIRCLIP RAD.DIAM.8 UNI7434	2
▲ ▽	KTRIO5834	CASTER KIT [QTY 2]	1
▲ ▲ 5	N/A	WHEEL D.50 GREY W/ PIVOT SOFT	2
▲ 6	N/A	DEFLECTOR LEO W/OR	1
▲ ▽	KTRIO5795	LATCH KIT [QTY 2]	1
▲ ▲ 7	N/A	HOOK PLAST.COMPL. GI-VAC	2
▲ ▲ 8	N/A	RIVET 4,8X18	4

▽ KIT

▲ INCLUDED IN KIT

N/A = NOT AVAILABLE SEPARATELY - MUST ORDER KIT

# VACUUM BAGS & MAIN FILTER ASSEMBLY

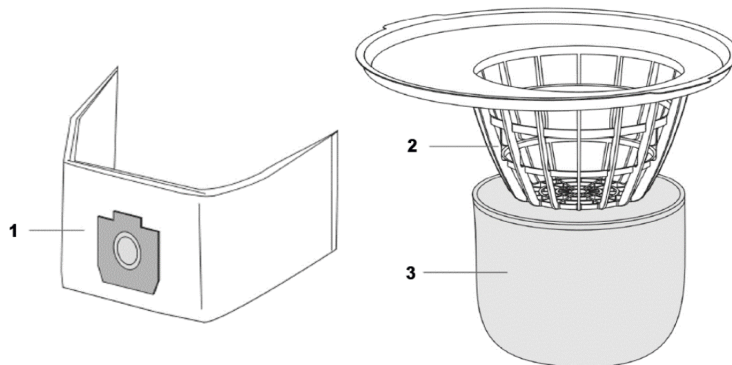

Code	Part No.	Description	QTY
1	9018690	BAG, VACUUM, PAPER [1 PKG = 10 BAGS]	1
1	9018692	BAG, VACUUM, MICROFIBER [1 PKG = 10 BAGS]	1
2	KTRIO5919	SUPPORT, FILTER BASKET	1
3	KTRIO5920	FILTER, POLYCARBONATE, MAIN	1

# ACCESSORY TOOLS

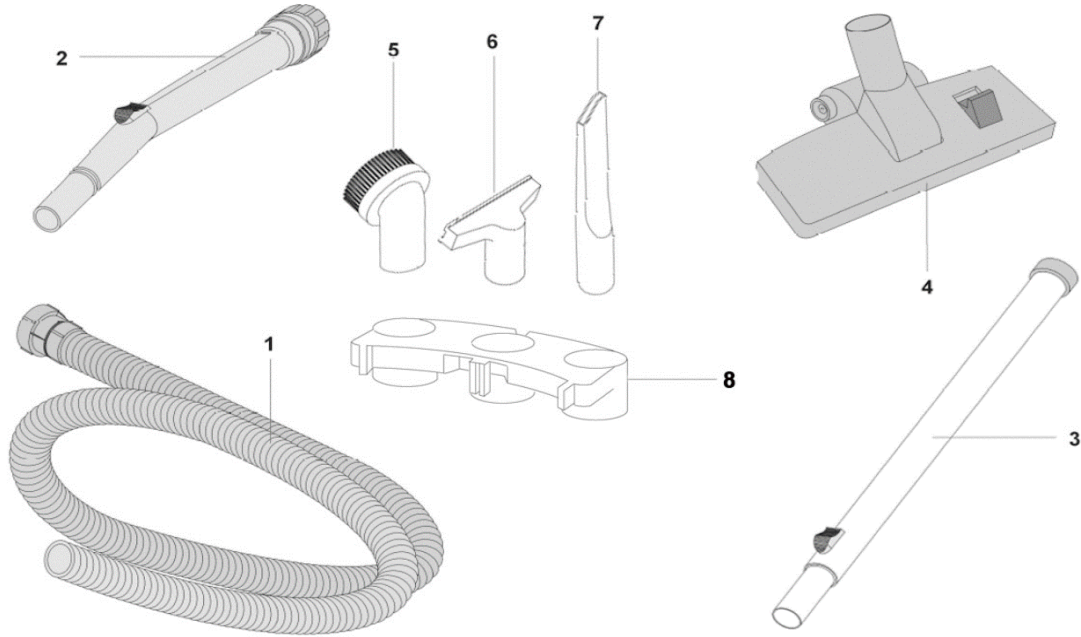

Code	Part No.	Description	QTY
1	KTRIO5905	HOSE ASSY, VACUUM, 2.5M, 32MM	1
2	KTRIO5906	HANDLE, VACUUM HOSE W/ REG, 32MM	1
3	KTRIO5921	WAND, CHROME, TELESCOPIC [32MM]	2
4	KTRIO5936	TOOL, FLOOR, DRY, DOUBLE USE [32MM]	1
▽	KTRIO5794	TOOL KIT, VACUUM, 32MM	1
▲	N/A	TOOL, ROUND BRUSH, 32MM	1
▲	N/A	TOOL, FURNITURE, 32MM	1
▲	N/A	TOOL, CREVICE, 32MM	1
8	KTRIO5942	HOLDER, TOOL [OPTIONAL]	1

# LABEL KIT

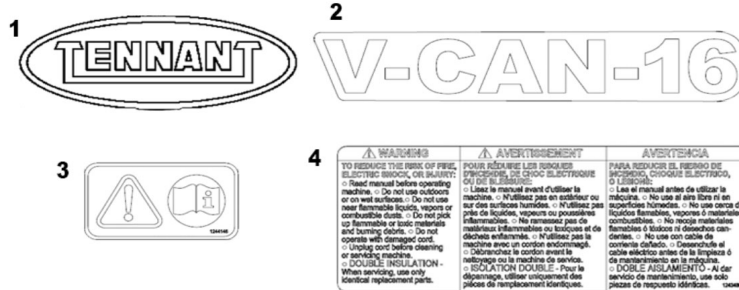

Code	Part No.	Description	QTY
▽	KTRIO5894	LABEL KIT, VACUUM [V-CAN-16 NA]	1
▲	1	N/A LABEL, LOGO, TENNANT	1
▲	2	N/A LABEL, MODEL [V-CAN-16]	2
▲	4	N/A LABEL, WARNING, EN/FR/ES [AC VAC]	1
▽	KTRIO5893	LABEL KIT, VACUUM [V-CAN-16, EMEA/APAC]	1
▲	1	N/A LABEL, LOGO, TENNANT	1
▲	2	N/A LABEL, MODEL [V-CAN-16]	2
▲	3	N/A LABEL, SAFETY, READ MANUAL [CE]	1
▽	KIT		
▲	INCLUDED IN KIT		

N/A = NOT AVAILABLE SEPARATELY - MUST ORDER KIT

# ELECTRICAL DIAGRAMS

## NA 120V MODEL

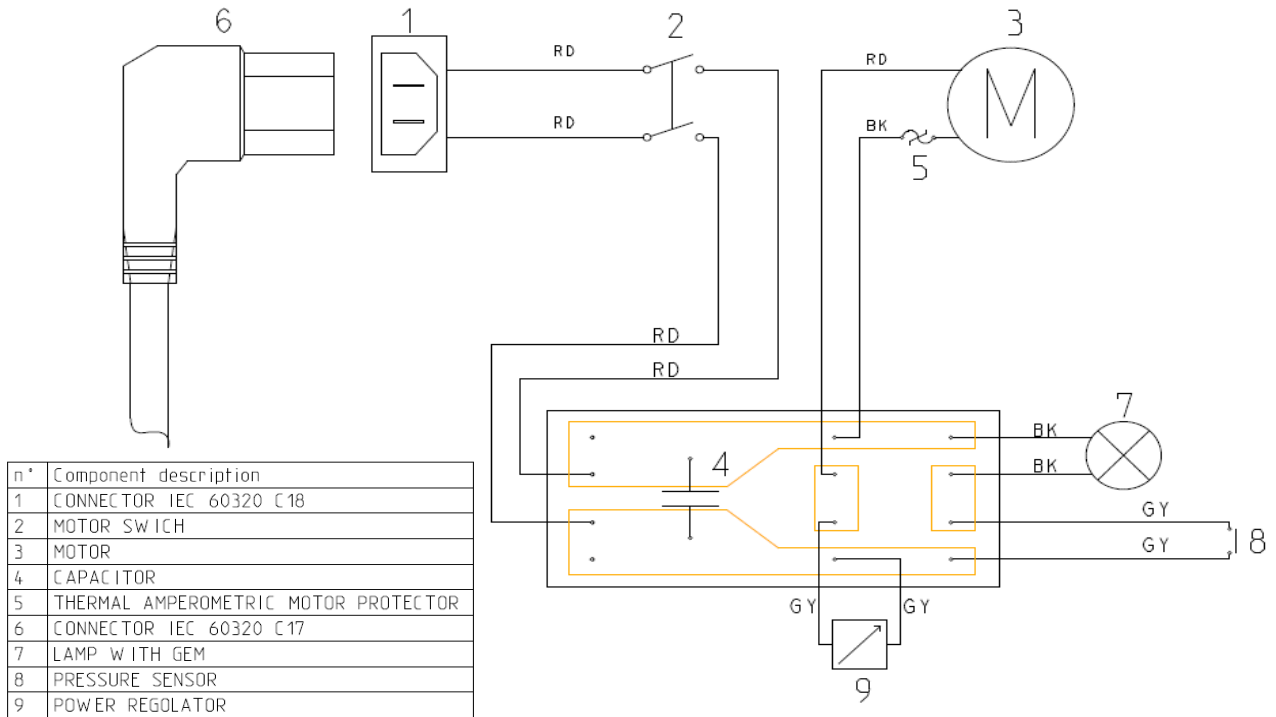

## EU/UK/ANZ 220-240V MODELS

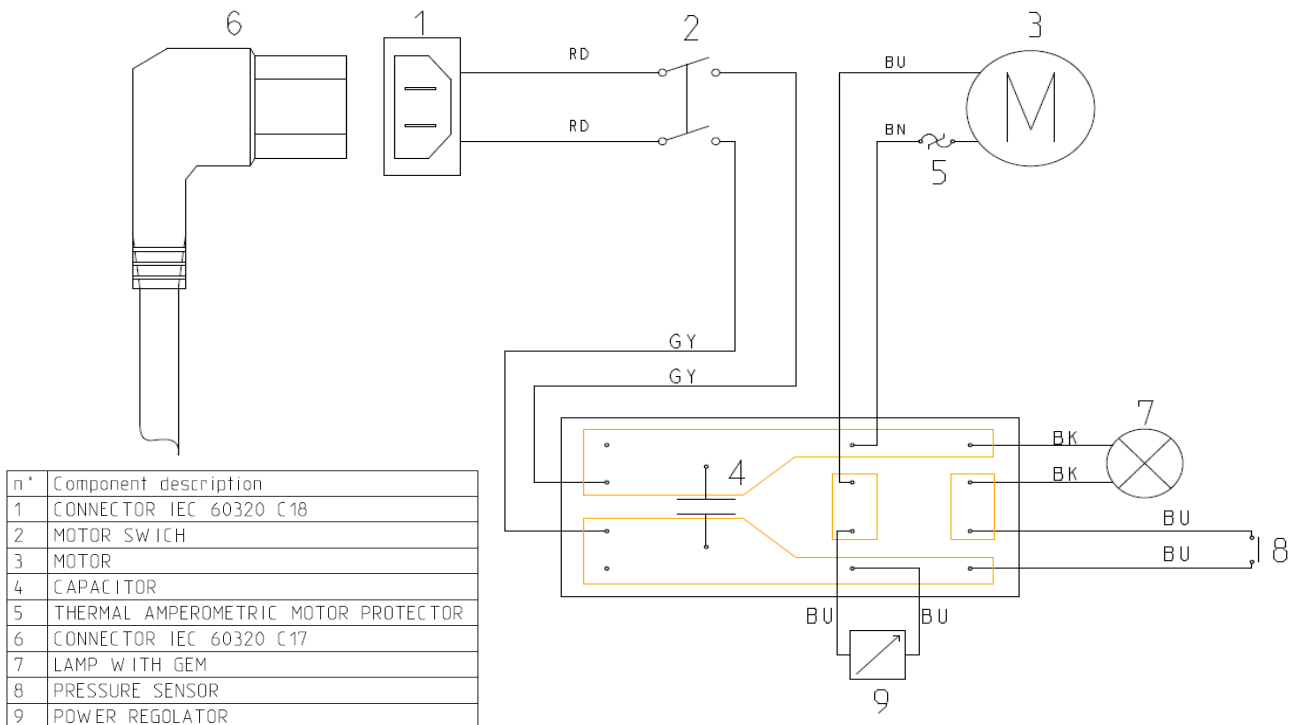

# ELECTRICAL DIAGRAMS

## CHINA 220-240V MODEL

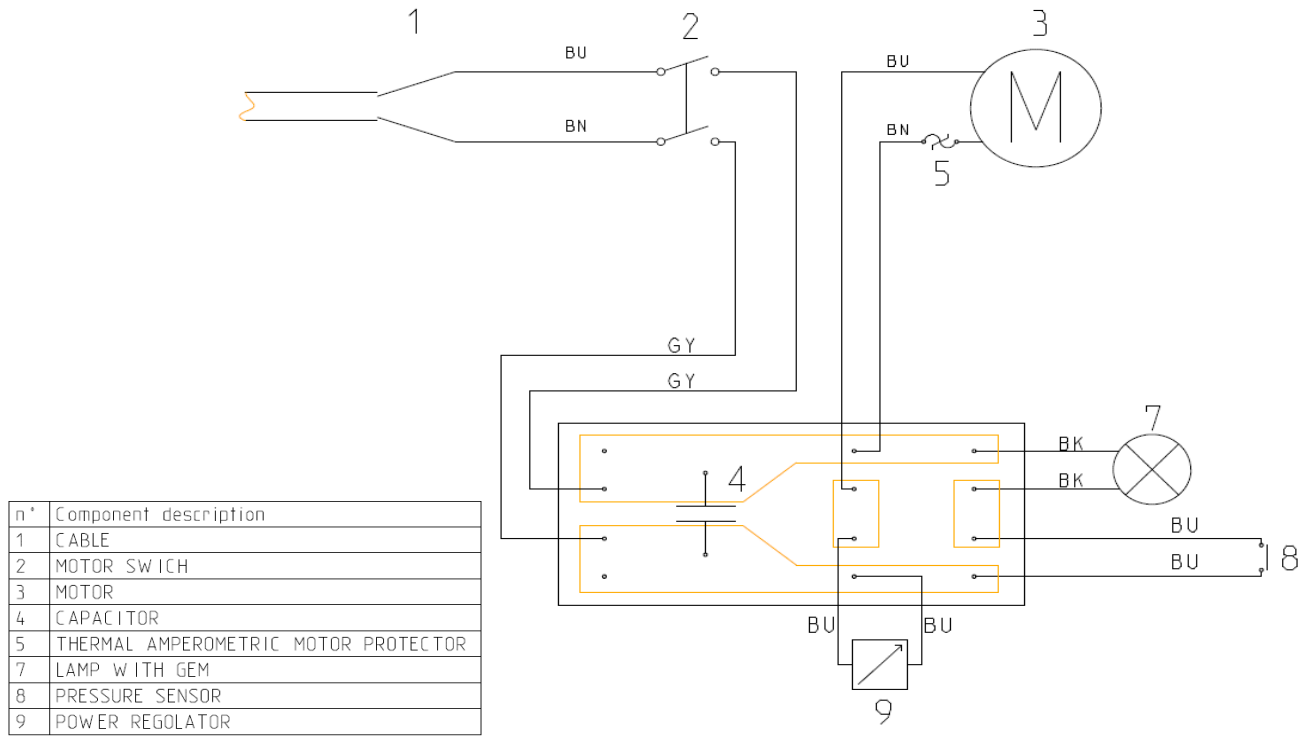

## JAPAN 100V MODEL

