



## **Electronic Service Manuals**

This electronic document is provided as a service to our customers. We do not create the contents of the information contained in this document. Should you have detailed questions pertaining to the information contained in this document, you may contact Michco, or the manufacturer which provided the original information in this electronic deliverable. Michco's only part in this electronic deliverable was the electronic assembly process. By providing this manual online we are not guaranteeing parts availability.

You may contact Michco through the following methods:

**Phone (517) 484-9312**

2011 N. High St. -- Lansing, Michigan -- 48906

Fax: (517) 484-9836

Email: [CustomerService@Michco.com](mailto:CustomerService@Michco.com)

Website: [www.Michco.Com](http://www.Michco.Com)

Order Parts online at:

**[www.Michco.Com](http://www.Michco.Com)**

Directly to Parts & Service:

By Email: **[CustomerService@Michco.com](mailto:CustomerService@Michco.com)**

By Fax: (517) 484-9836

By Voice: (517) 484-9312

**Serving the Cleaning Industry Since 1922**

Notice: All copyrighted material remains property of original owners, all trademarks are property of respective owners. Manuals are subject to Manufacturer's reproduction limitations. Originals or reproductions were provided by manufacturers through a request. We make no warranty as to the correctness of information provided in this document and you assume all risk. By placing these manuals on line we are not declaring our corporation to be an manufacturer authorized dealer or provider, please check our web site for authorized manufacturers we represent.



# V-CAN-12

Canister Dry Vacuum Cleaner

Parts Manual

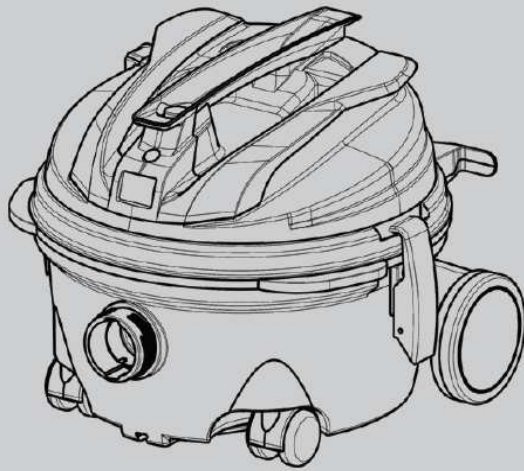

Model Part No.:

1244301 V-CAN-12 [120V NA]  
1244303 V-CAN-12 [220-240V EU]  
1244305 V-CAN-12 [220-240V UK]  
1247852 V-CAN-12 [220-240V FR]  
1244308 V-CAN-12 [220-240V ANZ]  
1244306 V-CAN-12 [220-240V CN]  
1244307 V-CAN-12 [100V JP]

**TennantTrue® Parts**

**Global**



To view, print or download the parts manual, visit:

[www.tennantco.com/manuals](http://www.tennantco.com/manuals)

9018759  
Rev. 01 (04-2019)

Only use TENNANT Company supplied or equivalent parts.  
Parts and supplies may be ordered online, by phone or from any Tennant or Nobles  
Authorized Service Center or Distributor.

Before Ordering any parts or supplies, be sure to have the machine model number and  
serial number available.

**Tennant Company**

PO Box 1452  
Minneapolis, MN 55440 USA  
Phone: (800) 553-8033  
[www.tennantco.com](http://www.tennantco.com)

**Tennant Company N.V.**

Industrielaan 6 5405 AB  
P.O. Box 6 5400 AA  
Uden- The Netherlands  
[europa@tennantco.com](mailto:europa@tennantco.com)  
[www.tennantco.com](http://www.tennantco.com)

**TENNANT Cleaning Systems &  
Equipment (Shanghai) Co., Ltd**

Building 1, No. 3777 Caoying Road  
Qingpu Shanghai, China 201712  
Phone: 86 21 6922 5333  
Fax: 86 21 69225151  
[www.tennant.co.cn](http://www.tennant.co.cn)

**TENNANT Company Japan**

9F Industry & Trade Center  
2 Yamashita- cho, Naka- ku  
Yokohama, Kanagawa 231- 0023  
Japan  
Phone: 81-45-640-5630  
Fax: 81-45-640-5604  
[www.tennant.co.jp](http://www.tennant.co.jp)

Specifications and parts are subject to change without notice.  
Copyright ©2019 TENNANT Company

## TABLE OF CONTENTS

HEAD ASSEMBLY (NA 120V MODEL) .....	4
HEAD ASSEMBLY (EU/UK/ANZ 220-240V MODELS) .....	6
HEAD ASSEMBLY (CHINA 220-240V MODEL) .....	8
HEAD ASSEMBLY (JAPAN 100V MODEL) .....	10
TANK ASSEMBLY .....	12
VACUUM BAGS & MAIN FILTER ASSEMBLY .....	12
ACCESSORY TOOLS .....	13
LABEL KIT .....	13
ELECTRICAL DIAGRAM .....	14

## RECOMMENDED SPARE PARTS LIST

VACUUM BAGS AND FILTERS	
9018690	BAG, VACUUM, PAPER [1 PKG = 10 BAGS]
9018692	BAG, VACUUM, MICROFIBER [1 PKG=10 BAGS]
KTRI05903	FILTER, EXHAUST [STANDARD]
KTRI05904	FILTER, HEPA CARTRIDGE, EXHAUST [OPTIONAL]
KRTI05902	FILTER KIT, VACUUM, MAIN
KRTI05919	SUPPORT, FILTER BASKET
CLEANING TOOL ACCESSORIES	
KTRI05905	HOSE ASSY, VACUUM, 2.5M [32MM]
KTRI05799	WAND SET, CHROME, 2 PIECE [32MM]
KTRI05906	HANDLE, VACUUM HOSE W/ REG [32MM]
KTRI05907	TOOL, FLOOR, DRY, DOUBLE USE [32MM]
KTRI05970	TOOL, FLOOR, DRY, DOUBLE USE [32MM] (FRANCE ONLY)
KTRI05942	TOOL HOLDER - OPTIONAL
KTRI05794	TOOL KIT, VACUUM [32MM]
GENERAL MAINTENANCE PARTS	
KTRI05834	CASTER KIT, VACUUM [QTY 2]
KTRI05795	LATCH KIT, VACUUM [QTY 2]
KTRI05908	SWITCH, ON/OFF
KTRI05909	CORD, POWER, 120V [NA]
KTRI05910	CORD, POWER, 220-240V [EU]
KTRI05911	CORD, POWER, 220-240V [UK]
KTRI05912	CORD, POWER, 220-240V [ANZ]
KTRI05797	CORD KIT, POWER, 220-240V [CN]
KTRI05796	CORD KIT, POWER, 100V [JP]
KTRI05913	MOTOR KIT, VACUUM, 800W, 120V/60HZ [NA]
KTRI05915	MOTOR KIT, VACUUM, 800W, 220-240V
KTRI05914	MOTOR KIT, VACUUM, 800W, 100V [JP]
KTRI05841	GASKET KIT, MOTOR
KTRI05916	COVER, FILTER, EXHAUST [V-CAN-12/16 NA]
KTRI05918	COVER, FILTER, EXHAUST [V-CAN-12/16 EMEA/APAC]

# HEAD ASSEMBLY (NA 120V MODEL)

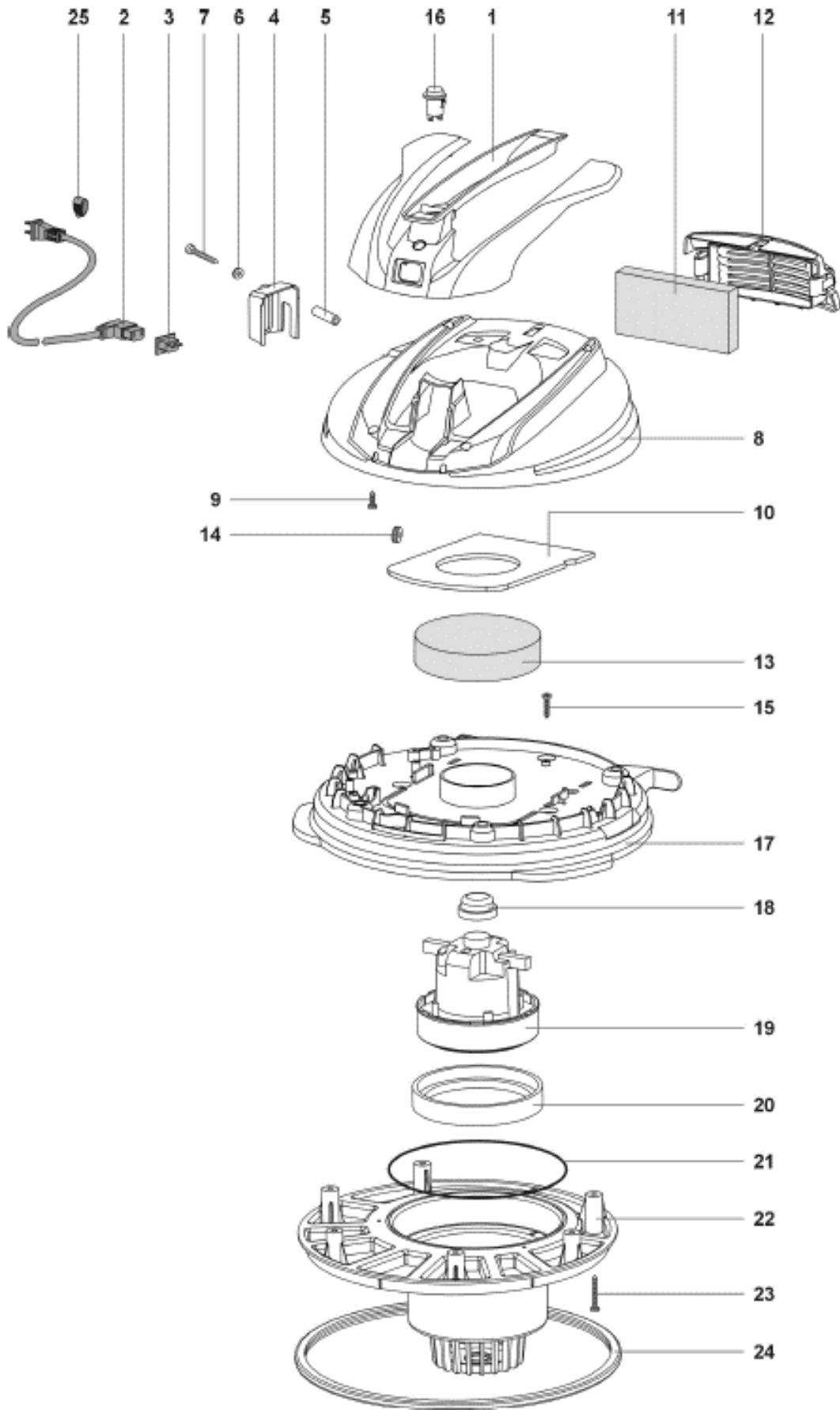

# HEAD ASSEMBLY (NA 120V MODEL)

Code	Part No.	Description	QTY
▽	KTRI05862	HOUSING ASSY, POWER, HEAD, 120V [V-CAN-12]	1
▲ ▽	KTRI05864	COVER KIT, VACUUM [V-CAN-12]	1
▲ ▲ 1	N/A	HANDLE TENNANT DRY GR55	1
▲ ▲ 2	KTRI05909	CORD, POWER, 120V [NA]	1
▲ ▲ 3	99932858	PLUG, MACH, 120V-230VAC	1
▲ ▲ ▽	KTRI05789	COVER KIT, CORD RETAINER [V-CAN]	1
▲ ▲ ▲ 4	N/A	COVER BL.CAVO TENNANT DRY BLT A [V-CAN-12]	1
▲ ▲ ▲ 5	N/A	SPACER BLOCCA CAVO [V-CAN-12]	1
▲ ▲ ▲ 6	N/A	WASHER M 6 UNI 6592	1
▲ ▲ ▲ 7	1021643	SCREW PAT TMT PHL 5X50	1
▲ ▲ 8	N/A	COVER TENNANT DRY BLU TEN AU [V-CAN-12]	1
▲ ▲ 9	1021706	SCREW PAT TMT PHL 5X14 ZN BLACK	5
▲ ▲ 10	N/A	GASKET ADESIVA COP. TEN DRY PE	1
▲ ▲ 11	KTRI05903	FILTER, EXHAUST	1
▲ ▲ 12	KTRI05916	COVER, FILTER, EXHAUST [V-CAN-12/16 NA]	1
▲ ▲ 14	N/A	GUIDING SLIT W/LEO MEMBRANE	1
▲ ▲ 16	KTRI05908	SWITCH	1
▲ ▲ N/S	1059271	WIRING 43CM MOTOR	1
▲ ▲ N/S	N/A	WIRING LEO	1
▲ 13	KTRI05931	FILTER, FOAM	1
▲ 15	1021628	SCREW PFU TMT PHL 5X20 BLACK	3
▲ 17	N/A	MOTOR FASTENER YVO DRY GR.55 AU	1
▲ ▽	KTRI05841	GASKET KIT, MOTOR	1
▲ ▲ 18	N/A	MOT.FASTENER GUM G.EPDM30 D42X20	1
▲ ▲ 20	N/A	GASKET A L D.130 H=13	1
▲ ▲ 21	N/A	O-RING GOMMA SPUGNA D.4 D.190	1
▲ 19	KTRI05913	MOTOR, 800W 120VAC 60HZ	1
▲ 22	N/A	LEO BASE	1
▲ 23	1021640	SCREW PAT TMT PHL 5X30 BLACK	6
▲ 24	KTRI05932	GASKET, HEAD ASSEMBLY	1
▲ 25	N/A	CLIP BIG FIXING CABL ELE	1

▽ KIT

▲ INCLUDED IN KIT

N/A = NOT AVAILABLE SEPARATELY - MUST ORDER KIT

# HEAD ASSEMBLY (EU/UK/ANZ 220-240V MODELS)

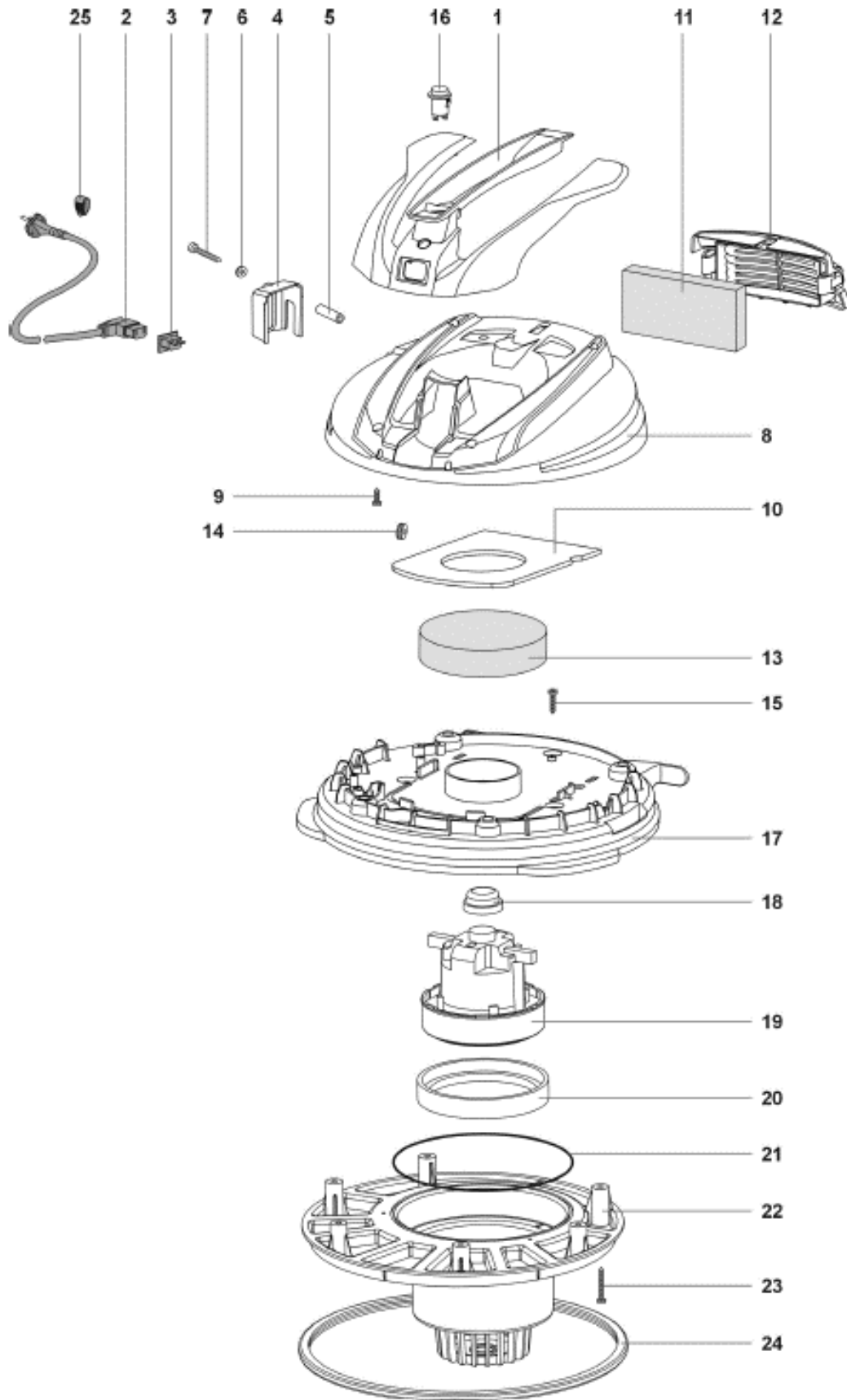

## HEAD ASSEMBLY (EU/UK/ANZ 220-240V MODELS)

Code	Part No.	Description	QTY
▽	KTRI05838	HOUSING ASSY, POWER, HEAD [V-CAN-12 EU UK ANZ]	1
▲ ▽	KTRI05844	COVER KIT, VACUUM [V-CAN-12 EU UK ANZ]	1
▲ ▲	1 N/A	HANDLE TENNANT DRY GR55	1
	2 KTRI05910	CORD, POWER, 220-240V [EU]	1
	2 KTRI05911	CORD, POWER, 220-240V [UK]	1
	2 KTRI05912	CORD, POWER, 220-240V [ANZ]	1
▲ ▲	3 99932858	PLUG, MACH, 120V-230VAC	1
▲ ▲ ▽	KTRI05788	COVER KIT, CORD RETAINER	1
▲ ▲ ▲	4 N/A	COVER BL.CAVO TENNANT DRY BLU T	1
▲ ▲ ▲	5 N/A	SPACER PLASTIC D.10 D.6,3X21	1
▲ ▲ ▲	6 N/A	G206	1
▲ ▲ ▲	7 1021643	SCREW PAT TMT PHL 5X50	1
▲ ▲	8 N/A	COVER TENNANT DRY BLU TEN	1
▲ ▲	9 1021706	SCREW PAT TMT PHL 5X14 ZN BLACK	5
▲ ▲	10 N/A	GASKET ADESIVA COP. TEN DRY PE	1
▲ ▲	11 KTRI05903	FILTER, EXHAUST	1
▲ ▲	12 KTRI05918	COVER, FILTER, EXHAUST [V-CAN-12/16 EMEA/APAC]	1
▲ ▲	14 N/A	GUIDING SLIT W/LEO MEMBRANE	1
▲ ▲	16 KTRI05908	SWITCH	1
▲ ▲	N/S 1059271	WIRING 43CM MOTOR	1
▲ ▲	N/S N/A	WIRING LEO	1
▲	13 KTRI05931	FILTER, FOAM	1
▲	15 1021628	SCREW PFU TMT PHL 5X20 BLACK	3
▲	17 N/A	MOTOR FASTENER YVO DRY GR.55	1
▲ ▽	KTRI05841	GASKET KIT, MOTOR	1
▲ ▲	18 N/A	MOT.FASTENER GUM G.EPDM30 D42X20	1
▲ ▲	20 N/A	GASKET A L D.130 H=13	1
▲ ▲	21 N/A	O-RING GOMMA SPUGNA D.4 D.190	1
▲	19 KTRI05915	MOTOR, 800W 220-240V [V-CAN-12]	1
▲	22 N/A	LEO BASE	1
▲	23 1021640	SCREW PAT TMT PHL 5X30 BLACK	6
▲	24 KTRI05932	GASKET, HEAD ASSEMBLY	1
▲	25 N/A	CLIP BIG FIXING CABL ELE	1

▽ KIT

▲ INCLUDED IN KIT

N/A = NOT AVAILABLE SEPARATELY - MUST ORDER KIT

# HEAD ASSEMBLY (CHINA 220-240V MODEL)

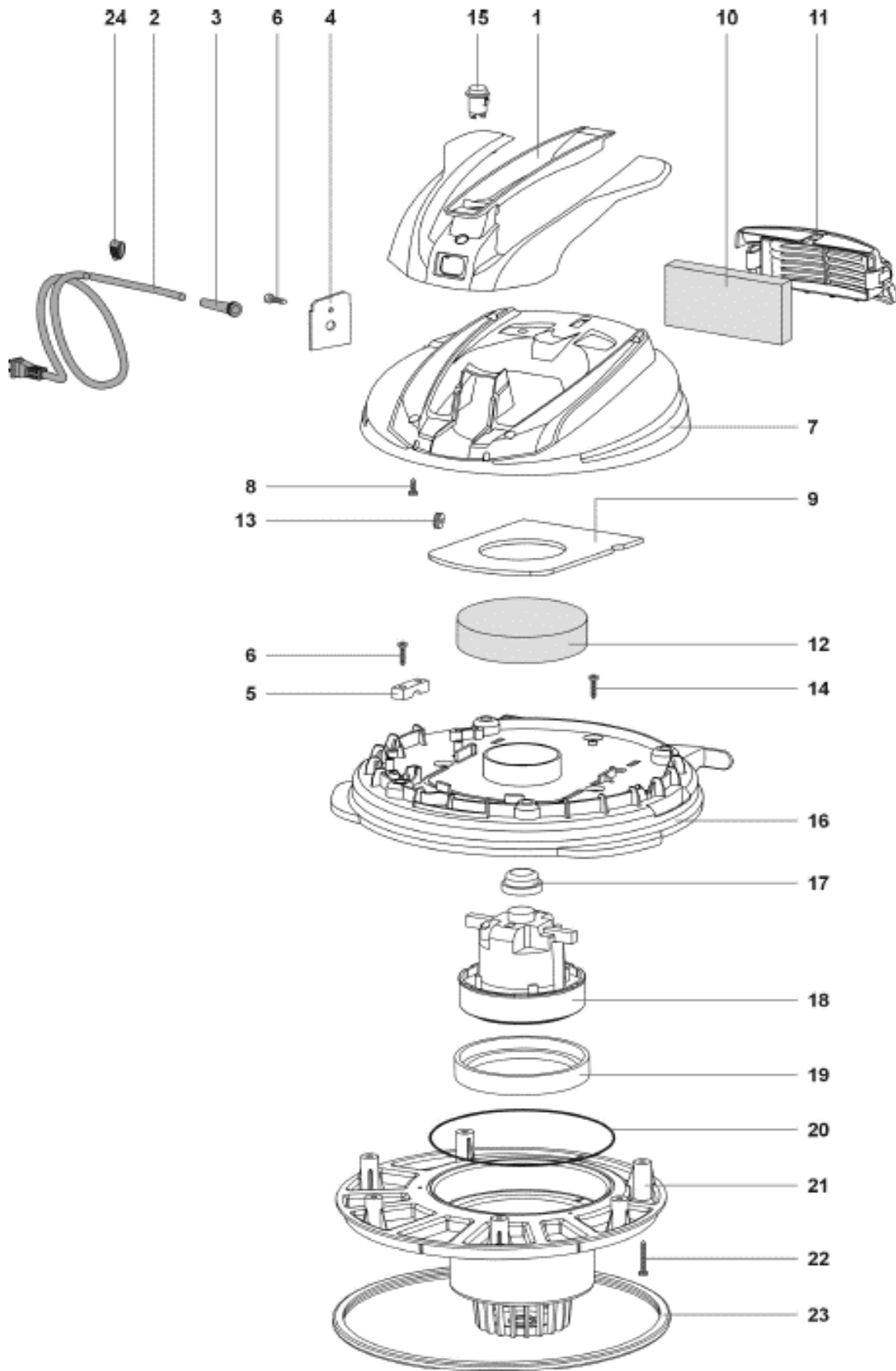

## HEAD ASSEMBLY (CHINA 220-240V MODEL)

Code	Part No.	Description	QTY
▽	KTRIO5867	HOUSING ASSY, POWER, HEAD [V-CAN-12 CN]	1
▲ ▽	KTRIO5869	COVER KIT, VACUUM [V-CAN-12 CN]	1
▲ ▲ 1	N/A	HANDLE TENNANT DRY GR55	1
▲ ▲ ▽	KTRIO5797	CORD, POWER, 220-240V [CN]	1
▲ ▲ ▲ 2	N/A	CABLE ELECTTRICO 2X0,75 MT.8,5 F [CN]	1
▲ ▲ ▲ 3	1021625	LEAD	1
▲ ▲ ▲ 4	N/A	COVER BL.CAVO TENNANT DRY BLU T	1
▲ ▲ ▲ 5	1021626	CABLE CLAMP	1
▲ ▲ ▲ 6	1021628	SCREW PFU TMT PHL 5X20 BLACK	3
▲ ▲ ▲ 24	N/A	CLIP BIG FIXING CABL ELE	1
▲ ▲ 7	N/A	COVER TENNANT DRY BLU TEN	1
▲ ▲ 8	1021706	SCREW PAT TMT PHL 5X14 ZN BLACK	5
▲ ▲ 9	N/A	GASKET ADESIVA COP. TEN DRY PE	1
▲ ▲ 10	KTRIO5903	FILTER, EXHAUST, FOAM	1
▲ ▲ 11	KTRIO5918	COVER, FILTER, EXHAUST [V-CAN-12/16 EMEA/APAC]	1
▲ ▲ 13	N/A	GUIDING SLIT W/LEO MEMBRANE	1
▲ ▲ 15	KTRIO5908	SWITCH	1
▲ ▲	N/A	WIRING 43CM MOTOR [CN]	1
▲ ▲ N/S	N/A	WIRING LEO	1
▲ 12	KTRIO5931	FILTER, FOAM	1
▲ 14	1021628	SCREW PFU TMT PHL 5X20 BLACK	3
▲ 16	N/A	MOTOR FASTENER YVO DRY GR.55	1
▲ ▽	KTRIO5841	GASKET KIT, MOTOR	1
▲ ▲ 17	N/A	MOT. FASTENER GUM G.EPDM30 D42X20	1
▲ ▲ 19	N/A	GASKET, MOTOR	1
▲ ▲ 20	N/A	O-RING GOMMA SPUGNA D.4 D.190	1
▲ 18	KTRIO5915	MOTOR, 800W 220-240VAC [V-CAN-12]	1
▲ 21	N/A	LEO BASE	1
▲ 22	1021640	SCREW PAT TMT PHL 5X30 BLACK	6
▲ 23	KTRIO5932	GASKET, HEADY ASSEMBLY	1

▽ KIT

▲ INCLUDED IN KIT

N/A = NOT AVAILABLE SEPARATELY - MUST ORDER KIT

# HEAD ASSEMBLY (JAPAN 100V MODEL)

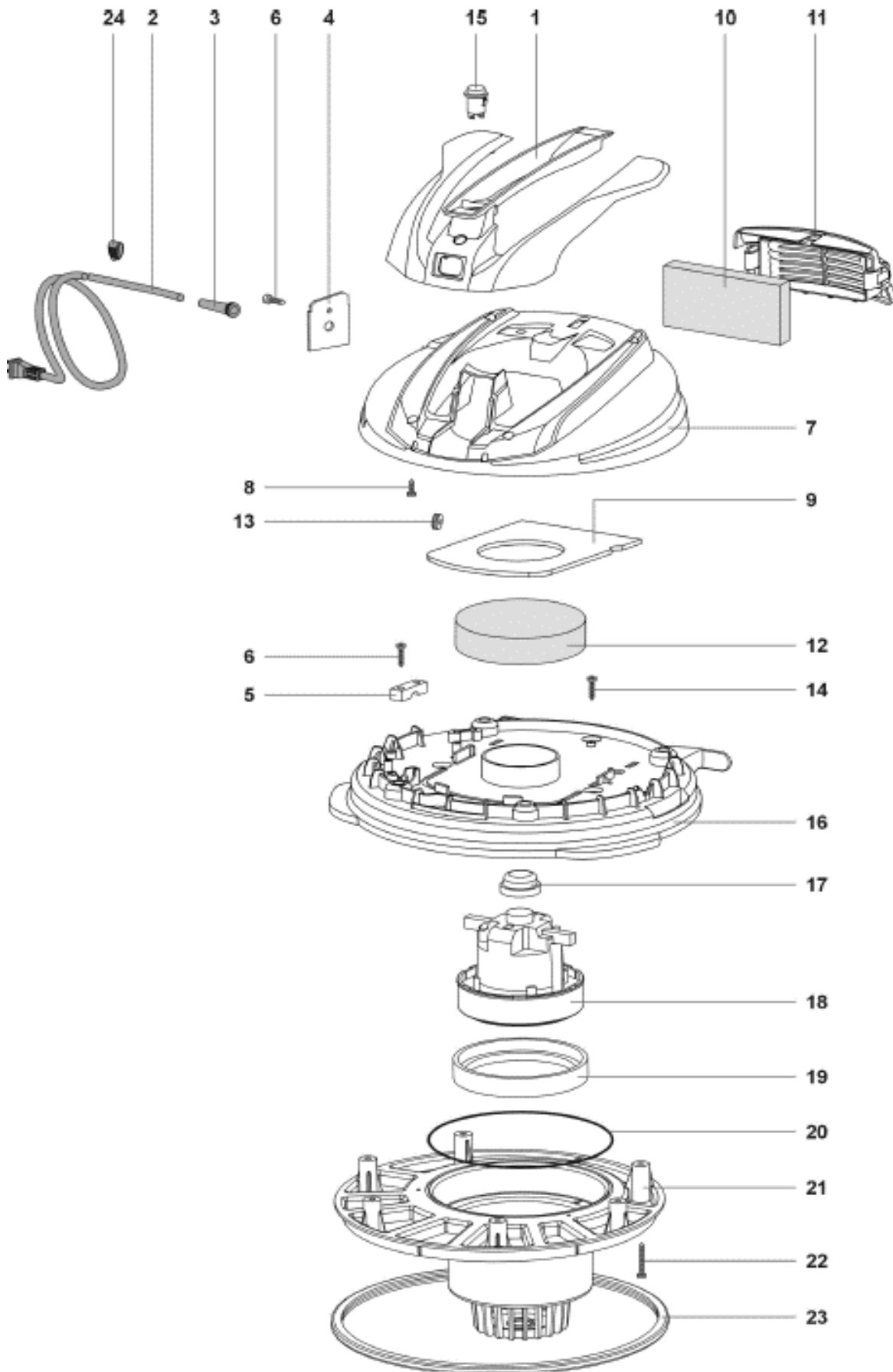

# HEAD ASSEMBLY (JAPAN 100V MODEL)

	Code	Part No.	Description	QTY
▽		KTRIO5866	HOUSING ASSY, POWER, HEAD [V-CAN-12 JP]	1
▲ ▽		KTRIO5868	COVER KIT, VACUUM [V-CAN-12 JP]	1
▲ ▲	1	N/A	HANDLE TENNANT DRY GR55	1
▲ ▲ ▽		KTRIO5796	CORD, POWER, 100V [JP]	1
▲ ▲ ▲	2	N/A	CABLE E.2X1 MT12 GI IEC320 [JP]	1
▲ ▲ ▲	3	1021625	LEAD	1
▲ ▲ ▲	4	N/A	COVER BL.CAVO TENNANT DRY BLU T	1
▲ ▲ ▲	5	1021626	CABLE CLAMP	1
▲ ▲ ▲	6	1021628	SCREW PFU TMT PHL 5X20 BLACK	3
▲ ▲ ▲	24	N/A	CLIP BIG FIXING CABL ELE	1
▲ ▲	7	N/A	COVER TENNANT DRY BLU TEN	1
▲ ▲	8	1021706	SCREW PAT TMT PHL 5X14 ZN BLACK	5
▲ ▲	9	N/A	GASKET ADESIVA COP. TEN DRY PE	1
▲ ▲	10	KTRIO5903	FILTER, EXHAUST, FOAM	1
▲ ▲	11	KTRIO5918	COVER, FILTER, EXHAUST [V-CAN-12/16 EMEA/APAC]	1
▲ ▲	13	N/A	GUIDING SLIT W/LEO MEMBRANE	1
▲ ▲	15	KTRIO5908	SWITCH	1
▲ ▲	CN	N/A	WIRING 43CM MOTOR [CN]	1
▲ ▲	N/S	N/A	WIRING LEO	1
▲	12	KTRIO5931	FILTER, FOAM	1
▲	14	1021628	SCREW PFU TMT PHL 5X20 BLACK	3
▲	16	N/A	MOTOR FASTENER YVO DRY GR.55	1
▲ ▽		KTRIO5841	GASKET KIT, MOTOR	1
▲ ▲	17	N/A	MOT.FASTENER GUM G.EPDM30 D42X20	1
▲ ▲	19	N/A	GASKET, MOTOR	1
▲ ▲	20	N/A	O-RING GOMMA SPUGNA D.4 D.190	1
▲	18	KTRIO5914	MOTOR, 800W 100VAC 50/60HZ [JP]	1
▲	21	N/A	LEO BASE	1
▲	22	1021640	SCREW PAT TMT PHL 5X30 BLACK	6
▲	23	KTRIO5932	GASKET, HEADY ASSEMBLY	1

▽ KIT

▲ INCLUDED IN KIT

N/A = NOT AVAILABLE SEPARATELY - MUST ORDER KIT

## TANK ASSEMBLY

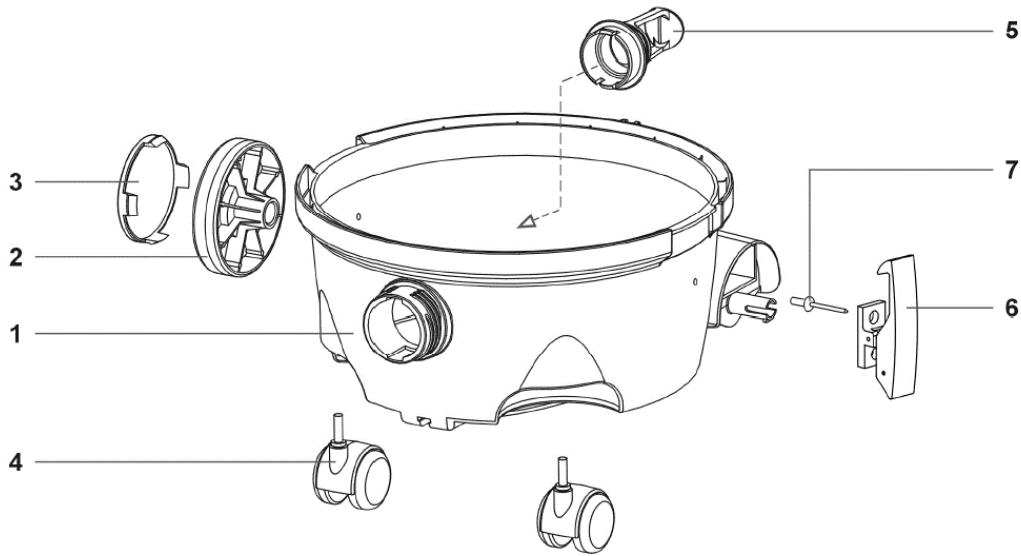

Code	Part no.	Description	QTY
▽	KTRI05835	TANK KIT, VACUUM w/ LABELS [V-CAN-12 EU/UK/ANZ/CN/JP]	1
▽	KTRI05836	TANK KIT, VACUUM w/ LABELS [V-CAN-12 NA]	1
▲ 1	N/A	TANK, VACUUM	1
▲ ▽	KTRI05792	WHEEL KIT [QTY 2]	1
▲ ▲ 2	N/A	WHEEL BODY RUBBERISED G55	2
▲ ▲ 3	N/A	WHEEL COVERING BLACK	2
▲ ▽	KTRI05834	CASTER KIT [QTY 2]	1
▲ ▲ 4	N/A	WHEEL D.50 GREY W/ PIVOT SOFT	2
▲ 5	N/A	DEFLECTOR W/OR	1
▲ ▽	KTRI05795	LATCH KIT [QTY 2]	1
▲ ▲ 6	N/A	HOOK PLAST.COMPL. GI-VAC	2
▲ ▲ 7	N/A	RIVET 4,8X18	4

▽ KIT

▲ INCLUDED IN KIT

N/A = NOT AVAILABLE SEPARATELY - MUST ORDER KIT

## VACUUM BAGS & MAIN FILTER ASSEMBLY

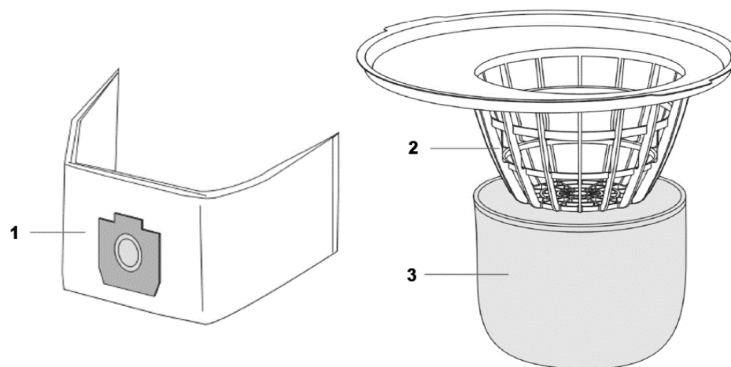

Code	Part No.	Description	QTY
1	9018690	BAG, VACUUM, PAPER [1 PKG = 10 BAGS]	1
1	9018692	BAG, VACUUM, MICROFIBER [1 PKG = 10 BAGS]	1
2	KTRI05919	SUPPORT, FILTER BASKET	1
3	KTRI05902	FILTER, POLYESTER, MAIN	1

# ACCESSORY TOOLS

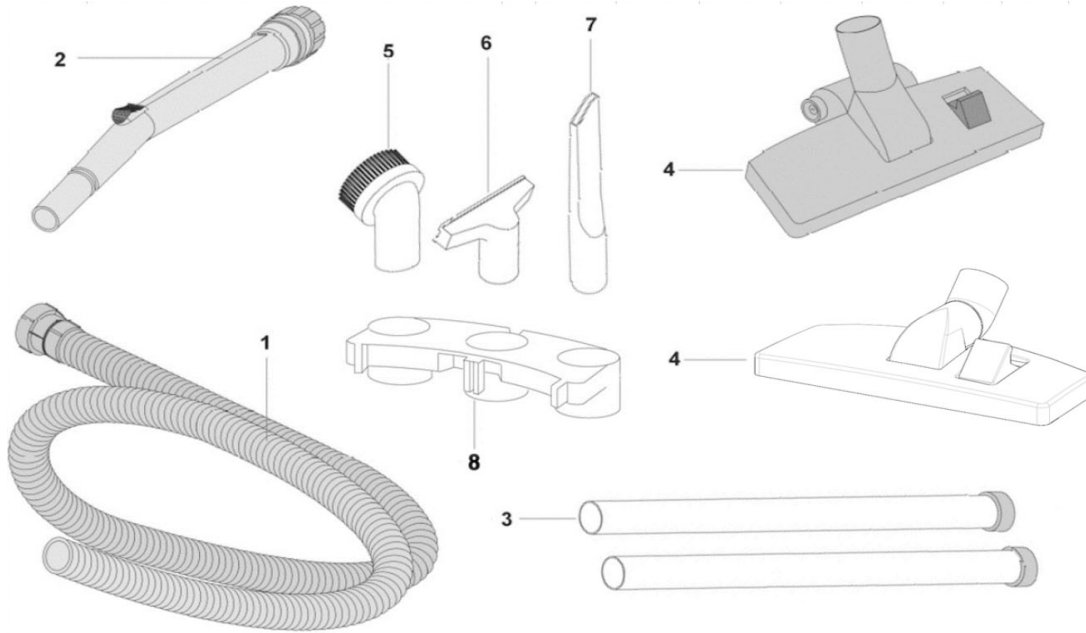

Code	Part No.	Description	QTY
	1	KTRI05905 HOSE ASSY, VACUUM, 2.5M, 32MM	1
	2	KTRI05906 HANDLE, VACUUM HOSE W/ REG, 32MM	1
	3	KTRI05799 WAND SET, CHROME, TWO-PIECE, 32MM	2
	4	KTRI05907 TOOL, FLOOR, DRY, DOUBLE USE [32MM]	1
	4	KTRI05970 TOOL, FLOOR, DRY, DOUBLE USE [32MM] (FRANCE ONLY)	1
▽	KTRI05794	TOOL KIT, VACUUM, 32MM	1
▲	5	N/A TOOL, ROUND BRUSH, 32MM	1
▲	6	N/A TOOL, FURNITURE, 32MM	1
▲	7	N/A TOOL, CREVICE, 32MM	1
	8	KTRI05942 HOLDER, TOOL [OPTIONAL]	1

# LABEL KIT

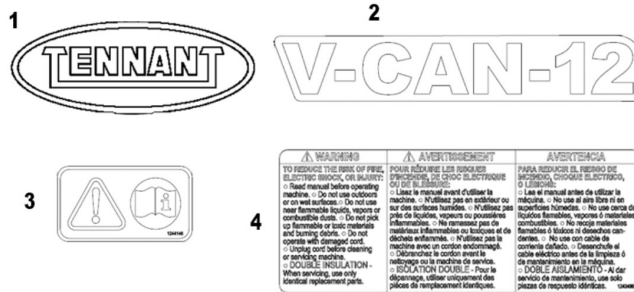

⚠ WARNING	⚠ AVERTISSEMENT	⚠ ADVERTENCIA
<p>TO REDUCE THE RISK OF FIRE, ELECTRIC SHOCK, OR BURNING: Do not use outdoors or on wet surfaces. Do not use near flammable liquids, vapors or combustible dusts. Do not pick up fireworks or toxic materials and burning debris. Do not connect with damaged cord. Unplug cord before opening or servicing machine. DOUBLE INSULATION - When servicing, use only identical replacement parts.</p>	<p>POUR RÉDUIRE LES RISQUES D'INCENDIE, DE CHOC ÉLECTRIQUE, DE BRÛLURE OU DE LÉSION: Ne pas utiliser en extérieur ou sur des surfaces humides. N'utilisez pas près de liquides, vapeurs ou poussières inflammables. Ne ramassez pas de déchets inflammables. N'utilisez pas de matériaux explosifs ou toxiques et des débris brûlants. Ne raccordez pas le câble avec un cordon endommagé. Débranchez le cordon avant le réglage ou la réparation de la machine. ISOLATION DOUBLE - Pour le dépannage, utiliser uniquement des pièces de remplacement identiques.</p>	<p>PARA REDUCIR EL RIESGO DE INCENDIO, CHOC ELÉCTRICO, QUEMADURAS O LESIONES: No use al aire libre ni en superficies húmedas. No use cerca de líquidos inflamables, vapores o materiales combustibles. No recoja materiales inflamables o tóxicos ni desechos calientes. No use con cable dañado. Desconecte el cable eléctrico antes de la limpieza o de mantenimiento en la máquina. DOBLE AISLAMIENTO - Al dar servicio de mantenimiento, use solo piezas de repuesto idénticas.</p>

Code	Part No.	Description	QTY
▽	KTRI05831	LABEL KIT, VACUUM [V-CAN-12, EMEA/APAC]	1
▲	1	N/A LABEL, LOGO, TENNANT	1
▲	2	N/A LABEL, MODEL [V-CAN-12]	2
▲	3	N/A LABEL, SAFETY, READ MANUAL [CE]	1
▽	KTRI05832	LABEL KIT, VACUUM [V-CAN-12 NA]	1
▲	1	N/A LABEL, LOGO, TENNANT	1
▲	2	N/A LABEL, MODEL [V-CAN-12]	2
▲	4	N/A LABEL, WARNING, EN/FR/ES [AC VAC]	1

▽ KIT

▲ INCLUDED IN KIT

N/A = NOT AVAILABLE SEPARATELY - MUST ORDER KIT

# ELECTRICAL DIAGRAMS

## NA 120V MODEL

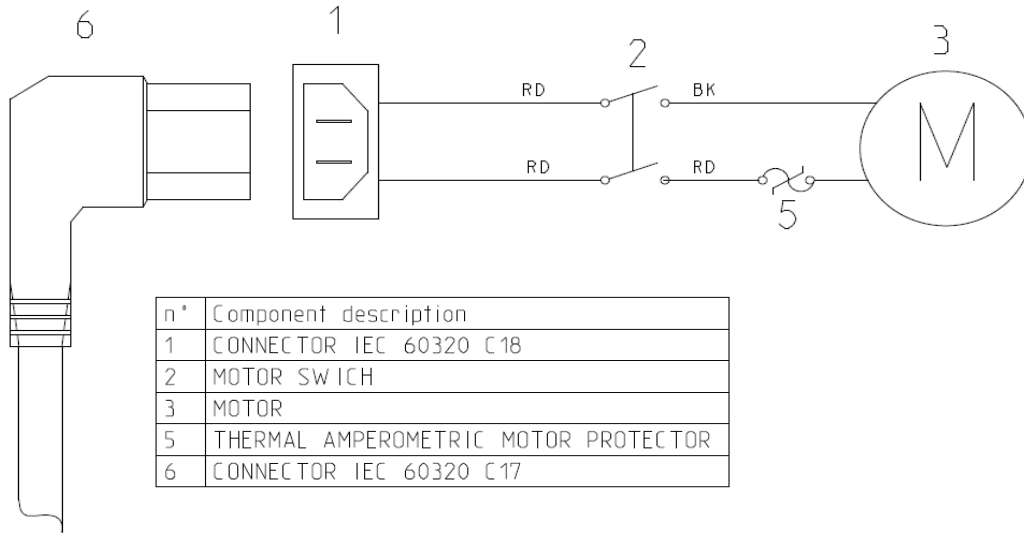

## EU/UK/ANZ 220-240V MODELS

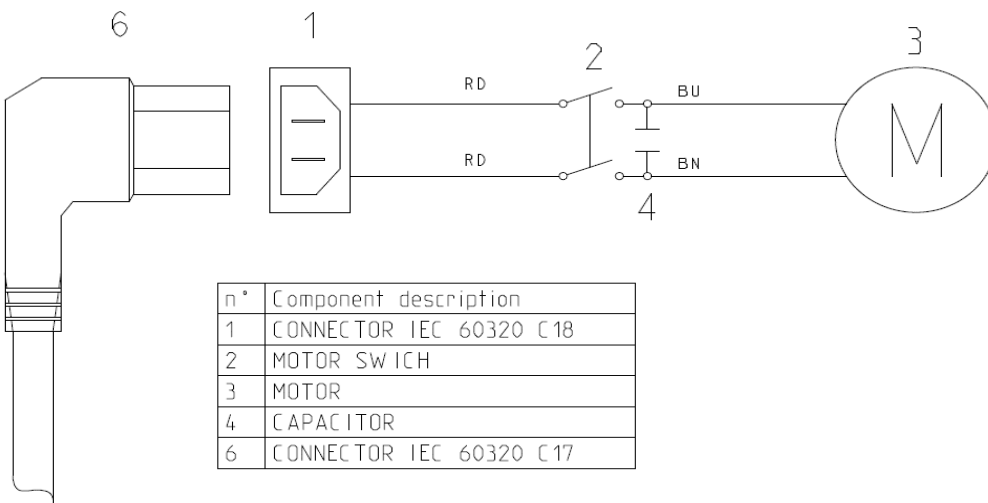

## JAPAN/CHINA MODELS

