



Electronic Service Manuals

This electronic document is provided as a service to our customers. We do not create the contents of the information contained in this document. Should you have detailed questions pertaining to the information contained in this document, you may contact Michco, or the manufacturer which provided the original information in this electronic deliverable. Michco's only part in this electronic deliverable was the electronic assembly process. By providing this manual on line we are not guaranteeing parts availability.

You may contact Michco through the following methods:

Phone (517) 484-9312 or (800) 331-3339

2011 N. High St. -- Lansing, Michigan -- 48906

Fax: (517) 484-9836

Email: CustServe@Michco.com

Web site: www.Michco.Com

Parts Web site: www.FloorMachineParts.Com

Order Parts on Line at:

www.FloorMachineParts.Com

Directly to Parts & Service:

By Email: **Shop@Michco.com**

By Fax: (517) 702-2041

By Voice: Use numbers above.

Serving the Cleaning Industry Since 1922

Notice: All copyrighted material remains property of original owners, all trademarks are property of respective owners. Manuals are subject to Manufacturer's reproduction limitations. Originals or reproductions were provided by manufacturers through a request. We make no warranty as to the correctness of information provided in this document and you assume all risk. By placing these manuals on line we are not declaring our corporation to be an manufacturer authorized dealer or provider, please check our web site for authorized manufacturers we represent.



186

(Parts Manual)

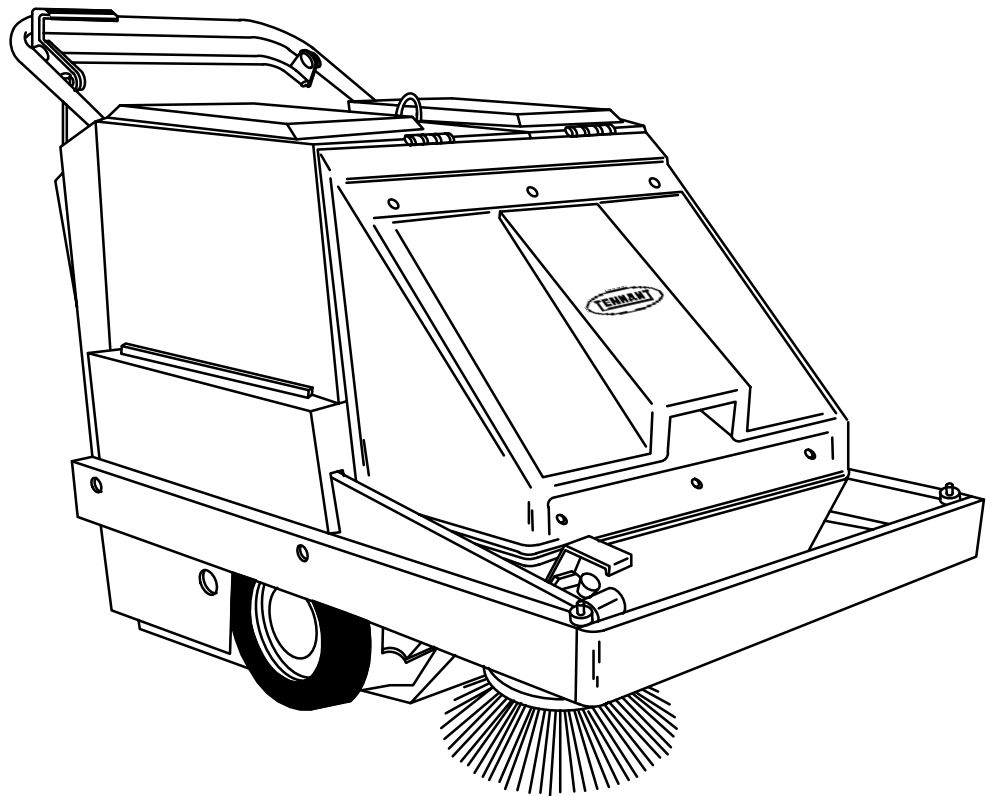

MM159
Rev. 05 (12-95)



This manual is furnished with each new TENNANT Model 186. It provides necessary operating and preventive maintenance instructions. Read this manual completely and understand the machine before operating or servicing it.

This manual covers all machine variations and standard options. The instruction portion of the manual consists of the Specification, Operation, Maintenance, and Appendix sections. The parts portion consists of the Standard Parts; Options; Electrical Components; and Cross Reference; sections.

All right side and left side references to the machine are determined by facing the direction of forward travel. All hardware considered to be of a common nature or locally available has been omitted from the parts sections. Be aware that this machine may contain metric hardware. Make sure you use equivalent hardware when replacement becomes necessary.

This machine will provide excellent service. However, the best results will be obtained at minimum costs if:

- The machine is operated with reasonable care.
- The machine is maintained regularly – per the maintenance instructions provided.
- The machine is maintained with TENNANT supplied or equivalent parts.

Parts and supplies may be ordered by phone or mail from any TENNANT parts and service center, distributor, or from any of the TENNANT subsidiaries. Before ordering parts or supplies, be sure to have your machine model number and serial number handy. Fill out the data block below for future reference.

MACHINE DATA <i>Please fill out at time of installation.</i>
Machine Serial Number – _____
Engine Serial Number – _____
Sales Representative – _____
Customer Number – _____
Date of Installation – _____
Manual Number – MM159
Revision: 05
Published: 12-95

Trademark Registered in: Austria, Benelux, Denmark, England, France, Germany, Italy, Spain, Switzerland, United States, Argentina, Australia, Canada, Japan, Mexico, Sweden, by TENNANT, Minneapolis, Minnesota, U.S.A.

Copyright 1990, 1991, 1992, 1994, 1995 TENNANT, Printed in U.S.A.

HOW TO USE THIS MANUAL

This section on *HOW TO USE THIS MANUAL* will tell you how to:

- Find important machine information for ordering correct repair parts.
- Find TENNANT part numbers.
- Order TENNANT parts and supplies.

IMPORTANT INFORMATION

When placing an order for parts, the machine model and machine serial number are important. Refer to the *MACHINE DATA* box which is filled out during the installation of your machine. The *MACHINE DATA* box is located on the inside of the front cover of this manual.

MACHINE DATA	
<i>Please fill out at time of installation.</i>	
Machine Serial Number -	_____
Engine Serial Number -	_____
Sales Representative -	_____
Customer Number -	_____
Date of Installation -	_____
Manual Number -	MM159
Revision:	10
Published:	6-94

The model number of your machine is on the side of the machine.

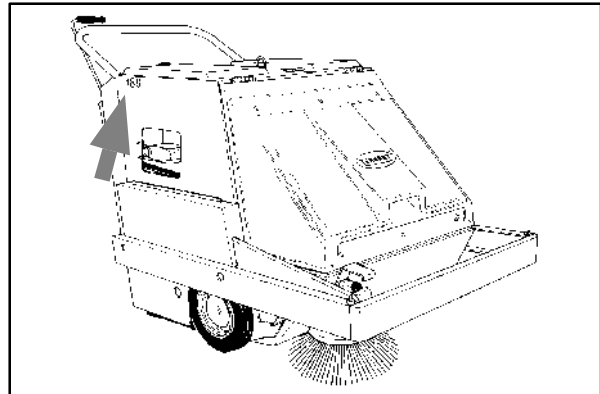

The serial number of your machine is printed on the machine data plate located as shown.

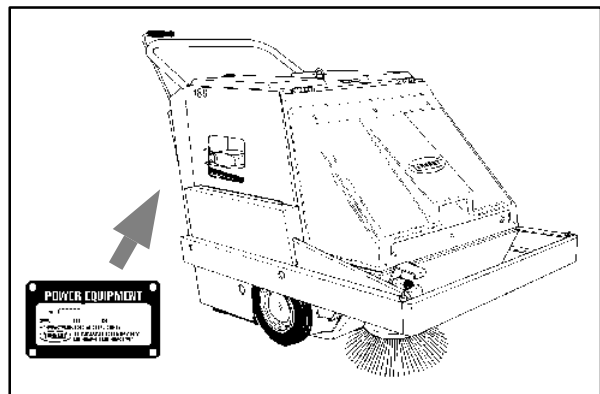

HOW TO USE THIS MANUAL

FINDING A TENNANT PART NUMBER

This manual contains the following sections:

- HOW TO USE THIS MANUAL
- STANDARD PARTS
- OPTIONS
- BREAKDOWNS
- CROSS REFERENCE

The STANDARD PARTS section lists repair parts for standard machines. They are grouped in this general order:

- General wear parts.
- Machine frame and related parts.
- Machine propelling system.
- Scrubbing components.
- Electrical parts.

The OPTION section lists repair parts of options.

The BREAKDOWN section lists available repair parts of major components.

All sections in this manual consist of parts illustrations and corresponding parts lists.

The parts illustrations are numbered with **Ref** numbers which refer to corresponding parts lists.

The parts lists include a number of columns of information:

- **Ref** – column refers to the reference number on the parts illustration.
- ∇ – indicates the part is an assembly.
- ▲ – indicates the part is included in the assembly listed just before it.
- **TENNANT Part No.** – column lists the TENNANT part number for the part.
- **Serial Number** – column indicates the set of machines the part number is applicable to. Serial numbers change when the machine design has been modified. The most current design of the machine is shown in the main illustration, older designs are boxed in a corner of the illustration.
- **Description** – column is a brief description of the part.
- **Qty.** – column lists the quantity of that part used in that area of the machine.

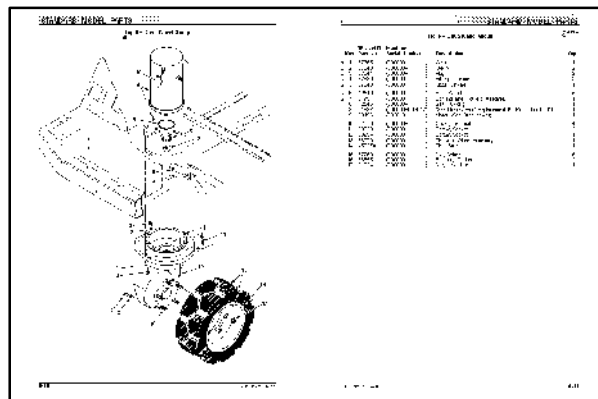

Key	TENNANT Part No.	Machine Serial Number	Description	Qty.
∇ 1	87366	(00000)-	Gearbox	1
▲ 2	87840	(00000)-	O-Ring	2
▲ 3	87841	(UUUUU)-	Hub	2
▲ 4	87839	(00000)-	Fitting, Grease	2
▲ 5	87849	(00000)-	Gear, Driving	1
▲ 6	12540	(00000)-	Bolt, Wheel	5
▲ 7	01791	(00000)-	Bearing and Housing Assembly	1
▲ 8	12545	(00000)-	Seal, O-Ring	1
9	31592	(00000-032017)	(See Breakdowns) Replacement Kit Motor For 86356	1
9	80196	(00015)-	Motor (See Breakdowns)	1
10	02076	(00000)-	Cover, Terminal	4
11	09000	(00000)-	Core, Socket	2
12	09294	(00000)-	Screw, Socket	1
13	86970	(00000)-	Tire and Wheel Assembly	1
14	45027A	(00000)-	Tire, Solid	1
15	87760	(00000)-	Nut, Wheel	5
16	56855	(00000)-	Bumper, Rubber	2
17	51824	(00000)-	Nut, Hex, "Tri	1

NOTE: If a service kit is installed on your machine, be sure to keep the **INSTRUCTION BULLETIN** which came with the kit. It contains repair parts numbers needed for ordering future parts.

NOTE: Fasteners used in this machine may be metric or non-metric. Take care when replacing hardware to replace with same thread size.

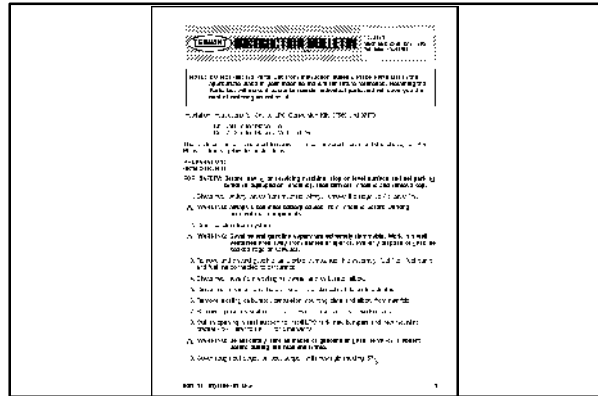

PLACING AN ORDER

Orders may be placed by phone, fax, or by mail. Phone orders may need written confirmation. Follow the steps below to insure prompt delivery:

1. Identify the model number of your machine.
2. Identify the serial number of your machine.
3. Find the part number of the part you need. Do not order by page number or reference number. If you are not able to find the part number, call your TENNANT representative for help or send the old part as a sample.
4. Determine the quantity of the part you need.
5. Provide the following company information:
 - Company name
 - Customer ID Number
 - Shipping address
 - Billing address
 - First and last name of person ordering parts
 - Telephone number
 - Purchase order number
6. Provide definitive shipping instructions.

HOW TO USE THIS MANUAL

Any claim for loss or damage to a shipment in transit should be filed promptly with the transportation company making the delivery. Shipments will be complete unless the packing list or order acknowledgement indicates items back ordered.

If parts received are suspected to be incorrect or defective, please contact the TENNANT representative from whom you ordered the part. They will give authorization for return and/or handle replacement shipments when required.

SECTION 6

CONTENTS

	Page
Fig. 1 – Recommended General Maintenance Items	6-2
Fig. 2 – Replacement Brushes	6-3
Fig. 3 – Main Frame Group	6-4
Fig. 4 – Engine, Sheaves and Cover Group	6-6
Fig. 5 – Covers Group	6-8
Fig. 6 – Handle and Battery Group	6-10
Fig. 7 – Engine and Sheaves Group	6-12
Fig. 8 – Engine and Fuel Tank Group, LPG	6-14
Fig. 9 – Brush Drive Group	6-16
Fig. 10 – Wheel Drive Group	6-18
Fig. 11 – Hopper Group	6-19
Fig. 12 – Vacuum Fan Group	6-20
Fig. 13 – Filter and Shaker Motor Group	6-21
Fig. 14 – Instrument Panel Group	6-22
Fig. 15 – Instrument Panel Group	6-23
Fig. 16 – Wire Harnesses Group, Gasoline	6-24
Fig. 17 – Wire Harnesses Group, Gasoline	6-26
Fig. 18 – Label Group	6-27
Fig. 19 – Label Group	6-28

Fig. 1 – Recommended General Maintenance Items

Key	TENNANT Part No.	Machine Serial Number	Description	Qty.
▽	60027	(000000–)	Maintenance Kit, Skirts	1
▲	08057	(000000–)	Skirt and Flap Assembly, Rear	1
▲	08703	(000000–)	Retainer, Rear Seal	1
▲	28072	(000000–)	Skirt, Side	2
▲	28250	(000000–)	Retainer, Side Skirt	1
▲	28026	(000000–)	Retainer, Front Side Skirt	1
▲	28081	(000000–)	Lip Assembly, Pan	2
▲	28277–1	(000000–)	Seal, Foam Rubber	1
▲	28277–2	(000000–)	Seal, Foam Rubber	1
▲	28025	(000000–)	Retainer	1
▲	47037	(000000–)	Adhesive, 5 oz (150 cc) Tube	1
▽	06732	(000000–)	Maintenance Kit, 200 Hour	1
▲	06649	(000000–005999)	Spark Plug	2
▲	30166	(006000–)	Spark Plug	2
▲	06816	(000000–)	Filter, Air	2
▲	06817	(000000–)	Pre-Cleaner, Air	1
▲	06818	(000000–)	Filter, Fuel	1
▽	01780	(000000–005999)	Performance Package, Squeegee	1
▲	03856	(000000–005999)	Blade, Rear Squeegee	1
▲	01657	(000000–005999)	Strip, Rear Backup	1
▲	63967	(000000–005999)	Blade, Front Squeegee	1

Fig. 2 – Replacement Brushes

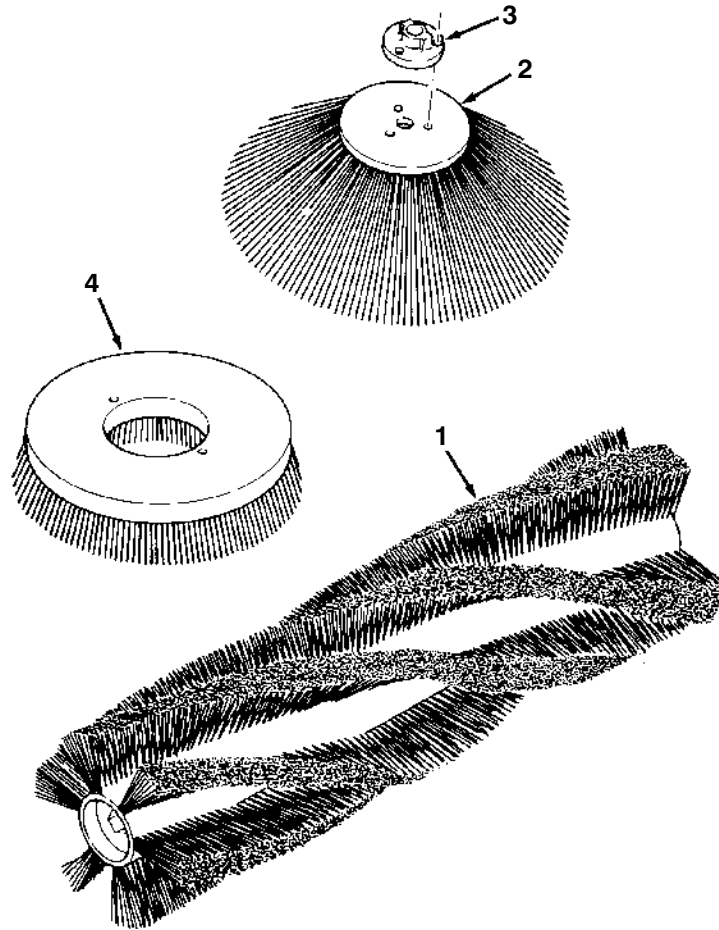

02842

Key	TENNANT Part No.	Machine Serial Number	Description	Qty.
1	28002	(000000–)	Main Brush, 6 Row, Wire and Fiber	1
1	28006	(000000–)	Main Brush, 6 Row, Union Mix	1
1	28006N	(000000–)	Main Brush, 6 Row, Nylon	1
1	28007P	(000000–)	Main Brush, 6 Row, Polypropylene	1
1	28172	(000000–)	Main Brush, 18 Row, Natural Fiber	1
1	28234	(000000–)	Main Brush, 50 Row, Tampico	1
1	28235	(000000–)	Main Brush, 18 Row, Wire and Fiber	1
1	28660	(000000–)	Main Brush, 6 Row, Bright Wire	1
1	29006	(000000–)	Main Brush, Scrubbing 18 Row, Stainless Steel	1
1	29408	(000000–)	Main Brush, Scrubbing 24 Row, Polypropylene	1
∇ 2	28096P	(000000–)	Side Brush and Hub Assembly, Polypropylene	1
▲ 3	45154	(000000–)	Hub, Side Brush	1
∇	28096N	(000000–)	Side Brush and Hub Assembly, Perlon	1
▲	45154	(000000–)	Hub, Side Brush	1
4	29406	(000000–)	Side Brush, Scrubbing Polypropylene	1

Fig. 3 – Main Frame Group

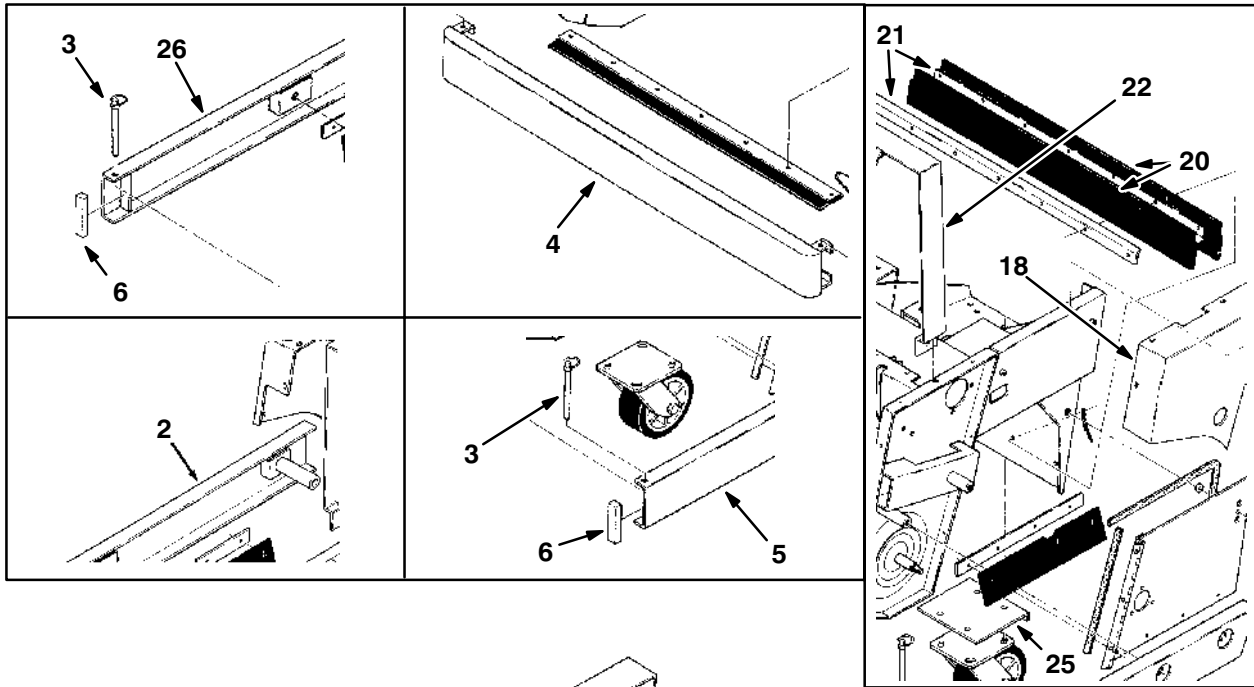
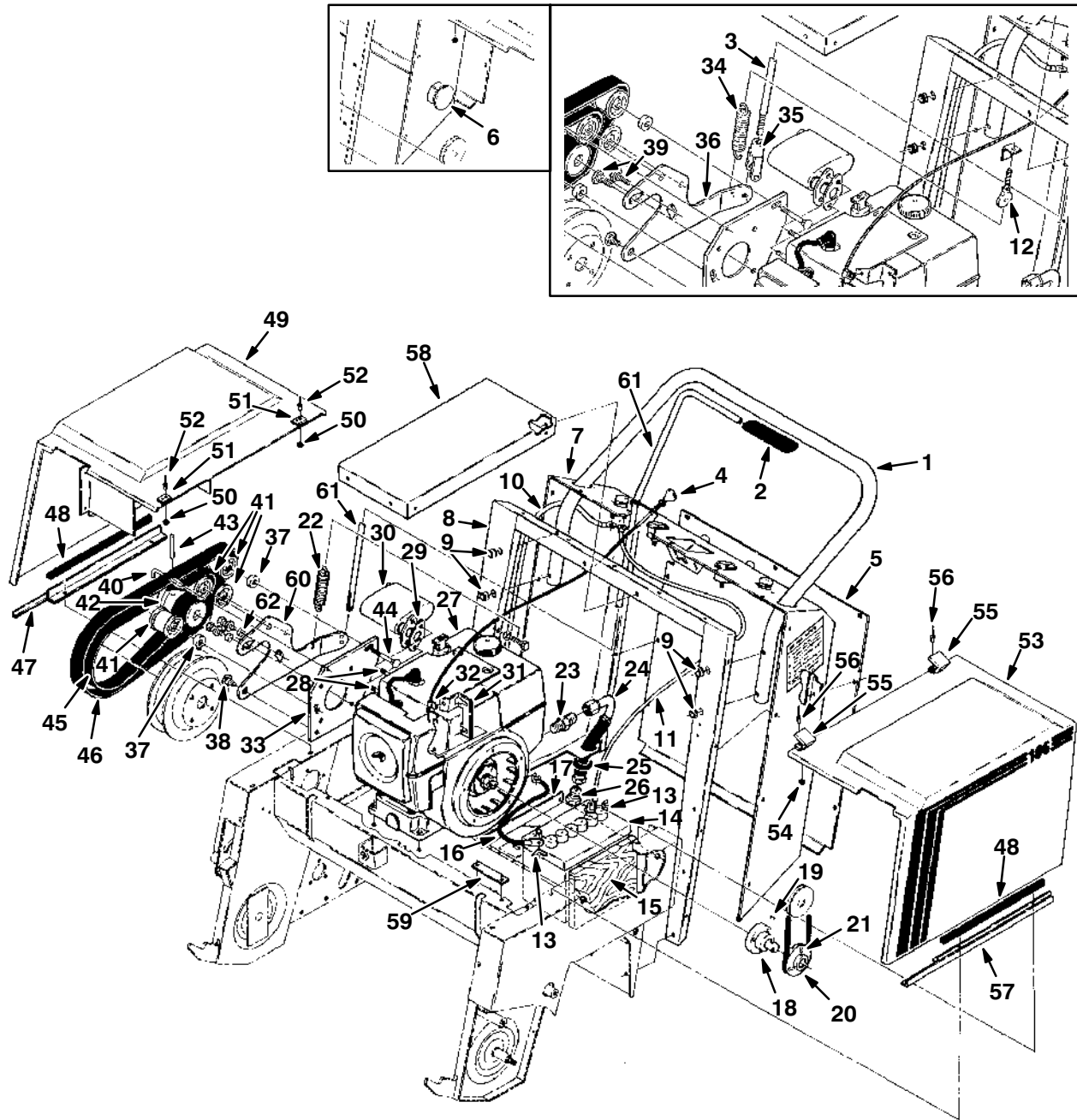

Fig. 3 – Main Frame Group

Key	TENNANT Part No.	Machine Serial Number	Description	Qty
1	01235	(000000–)	Cover, Right Side	1
2	01246	(000000–001599)	Bumper, R.H.	1
3	01317	(000000–007142)	Pin,Pivot 3.5Lg	2
4	61324	(000000–007142)	Replacement Kit, Front Bumper F/01327	1
5	01247	(000000–007142)	Bumper,Weldmt Left	1
6	28988–1	(000000–007142)	Seal,Foam Rbr, .50.75W 3.0L	2
7	06469	(000000–)	Door Assy	1
8	28277–1	(000000–)	Seal,Foam Rbr, .19.38W 19.3L	1
9	28277–2	(000000–)	Seal,Foam Rbr, .19.38W 9.6L	1
10	28072	(000000–)	Skirt,Side	2
11	28025	(000000–)	Retainer	1
12	28026	(000000–)	Retainer,Skirt Lt Side Frt	1
13	28250	(000000–)	Retainer,Skirt Rt Side Rear	1
14	28081	(000000–)	Lip Assy,Pan	1
15	12063	(000000–)	Frame, Main W/Label	1
16	18645	(000000–007335)	Caster–5”Dia.	1
16	65548	(007336–)	Caster–5”Dia.	1
17	01318	(000000–)	Tip,Rubber	1
18	01234	(000000–005999)	Cover Wldt	1
19	28499	(000000–)	Chain,Sash#35 ,6 Links L	1
20	28071	(000000–002674)	Skirt,Rear	2
21	01131	(000000–002674)	Retainer, Rear Seal	2
22	01166	(000000–005999)	Lintel Weldmt	1
23	29982	(000000–)	Knob,0.31–06,1.38Dia,Plastic	1
24	08156	(000000–)	Retainer, Screw	1
25	08087	(000000–002554)	Stiffener, Caster	1
26	10226	(001600–007142)	Bumper, R.H.	1
27	01251	(001600–)	Tube	1
28	08057	(002675–)	Skirt & Flap, Rear	1
29	08703	(002675–)	Retainer, Rear Seal	1
30	50938	(006000–)	Cover, Wldt Lh	1
31	50931	(006000–)	Lever Wldt, Brake	1
32	09480	(006000–)	Sprng,Tens,1.10Dx.15Wire 3.2Lg	1
33	41305	(006000–)	Pin, Clevis, 0.37 Dia X 0.75 Lg	1
34	50711	(006000–)	Lintel Wldt	1
35	61326	(007143–)	Bumper, R.H.	1
36	61327	(007143–)	Bumper, L.H.	1
37	61322	(007143–)	Bumper, Front	1

Fig. 4 – Engine, Sheaves and Cover Group



03054

Key	TENNANT Part No.	Machine Serial Number	Description	Qty.
1	01195	(000000-005999)	Handle	1
2	08086	(000000-005999)	Grip, Handle	1
3	01271	(000000-002506)	Rod, Directional Control	1
4	08078	(000000-005999)	Cable, Choke	1
5	01198	(000000-005999)	Cover, Back	1
6	82747	(000000-002289)	Plugbutton	1
7	12065	(000000-004368)	Panel and Label Assembly, Instrument	1
7	30201	(004369-005999)	Panel and Label Assembly, Instrument	1
8	01142	(000000-005999)	Support, Rear	1
9	10632-12	(000000-005999)	Grommet	4

Key	TENNANT Part No.	Machine Serial Number	Description	Qty.
10	19979	(000000-005999)	Cable Assembly, Positive	1
11	01365	(000000-005999)	Wire Assembly, Cable	1
12	22328	(000000-001474)	Eyebolt	1
13	39270	(000000-005999)	Nut, Wing	2
14	10134	(000000-005999)	Battery, Wet, 260 CCA	1
14	10135	(000000-005999)	Battery, Dry, 260 CCA	1
15	28973	(000000-005999)	Pad, Battery	1
16	01366	(000000-005999)	Wire Assembly, Cable	1
17	01136	(000000-005999)	Strap, Battery	1
18	06664	(000000-005999)	Shaft, Vacuum Drive	1
19	00500-6	(000000-005999)	Key, Woodruff	1
20	01103	(000000-005999)	Sheave	1
21	46820	(000000-005999)	Screw, Nylon Set	2
22	29545	(001475-005999)	Spring, Tension	1
23	15687	(000000-005999)	Fitting, Straight	1
24	55762	(000000-005999)	Hose, Hydraulic	1
25	10632-14	(000000-005999)	Grommet	1
26	16376	(000000-005999)	Fitting, Plug	1
27	01280	(000000-005999)	Engine, Gasoline	1
28	54396	(000000-005999)	Screw, Hex	2
29	01089	(000000-005999)	Gasket, Exhaust	1
30	01240	(000000-005999)	Muffler, Exhaust	1
31	01156	(000000-005999)	Bracket, Choke	1
32	26414	(000000-005999)	Clamp, Cable	1
33	25921	(000000-005999)	Plate, Directional Pivot	1
34	01274	(000000-001474)	Spring, Tension	1
35	14330	(000000-002506)	Yoke, Adjustable	1
36	08041	(000000-002506)	Replacement Kit, Lever	1
37	01113	(000000-005999)	Spacer, Directional Plate	2
38	01112	(000000-005999)	Screw, Shoulder	1
39	12966	(000000-003324)	Screw Replacement Kit, Shoulder	2
40	01134	(000000-005999)	Retainer, Belt	1
41	01199	(000000-005999)	Sheave, Idler	4
42	01115	(000000-005999)	Sheave, Combination	1
43	11398	(000000-005999)	Pin, Roll	1
44	01150	(000000-005999)	Bolt, Carriage	1
45	01119	(000000-005999)	Belt, Flat, Forward	1
46	01120	(000000-005999)	Belt, Flat, Reverse	1
47	01194	(000000-005999)	Retainer, Cover, R.H.	1
48	62170-1	(000000-005999)	Molding, Rigid	2
▽ 49	12984	(000000-005999)	Cover Assembly, R.H.	1
▲ 50	64757	(000000-005999)	Bumper, Rubber	2
▲ 51	01144	(000000-005999)	Closure, Edge Mating	2
▲ 52	01335	(000000-005999)	Rivet, Soft	4
▽ 53	06468	(000000-005999)	Cover Assembly, L.H.	1
▲ 54	64757	(000000-005999)	Bumper, Rubber	2
▲ 55	01144	(000000-005999)	Closure, Edge Mating	2
▲ 56	01335	(000000-005999)	Rivet, Soft	4
57	01331	(000000-005999)	Retainer, Cover, L.H.	1
58	01180	(000000-005999)	Brace, Center	1
59	06473	(000000-005999)	Strip, Dump Stop	1
60	08037	(002507-005999)	Lever, Directional Control	1
61	08036	(002507-005999)	Rod, Directional	1
62	12955	(003325-005999)	Sleeve	2

Fig. 5 – Covers Group

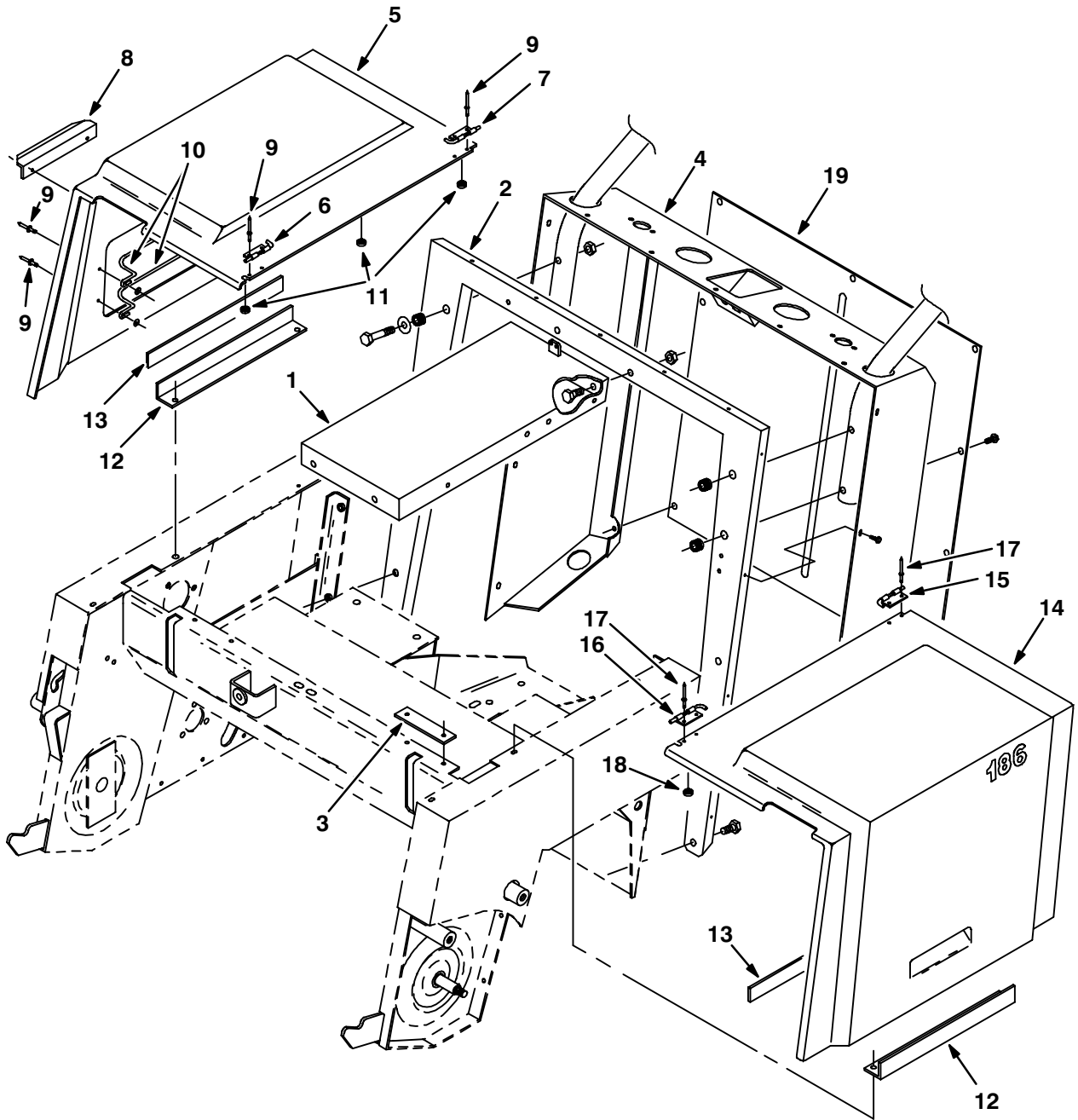

Fig. 5 – Covers Group

Key	TENNANT Part No.	Machine Serial Number	Description	Qty
1	09486	(006000–)	Channel Wldt, Center G	1
2	01142	(006000–)	Support Weldmt, Rear	1
3	06473	(006000–)	Bar, Hopper Stop	1
4	41285	(006000–)	Panel, Instr, 186G W/Label	1
▽ 5	61066	(006000–)	Cover Assy, Rh 186/1186G	1
▲ 6	50832	(006000–)	Hinge, Pull Pin Lh	1
▲ 7	50835	(006000–)	Hinge, Pull Pin Rh	1
▲ 8	50894	(006000–)	Handle, Cover	1
▲ 9	01335	(006000–)	Rivet, Pop–.125Dx.44X.25Dhd Al	10
▲ 10	12964	(006000–)	Guard, Muffler	2
▲ 11	64757	(006000–)	Bumper, Rubber .50Dia	3
12	09494	(006000–)	Angle, Stop	2
13	09367	(006000–)	Magnetic Strip, Flex1.0 .06 11	2
▽ 14	61067	(006000–)	Cover Assy, Lh 186/1186E&G	1
▲ 15	50832	(006000–)	Hinge, Pull Pin Lh	1
▲ 16	50835	(006000–)	Hinge, Pull Pin Rh	1
▲ 17	01335	(006000–)	Rivet, Pop–.125Dx.44X.25Dhd Al	4
▲ 18	64757	(006000–)	Bumper,Rubber .50Dia	3
▲ 19	50744	(006000–)	Cover, Back	1

Fig. 6 – Handle and Battery Group

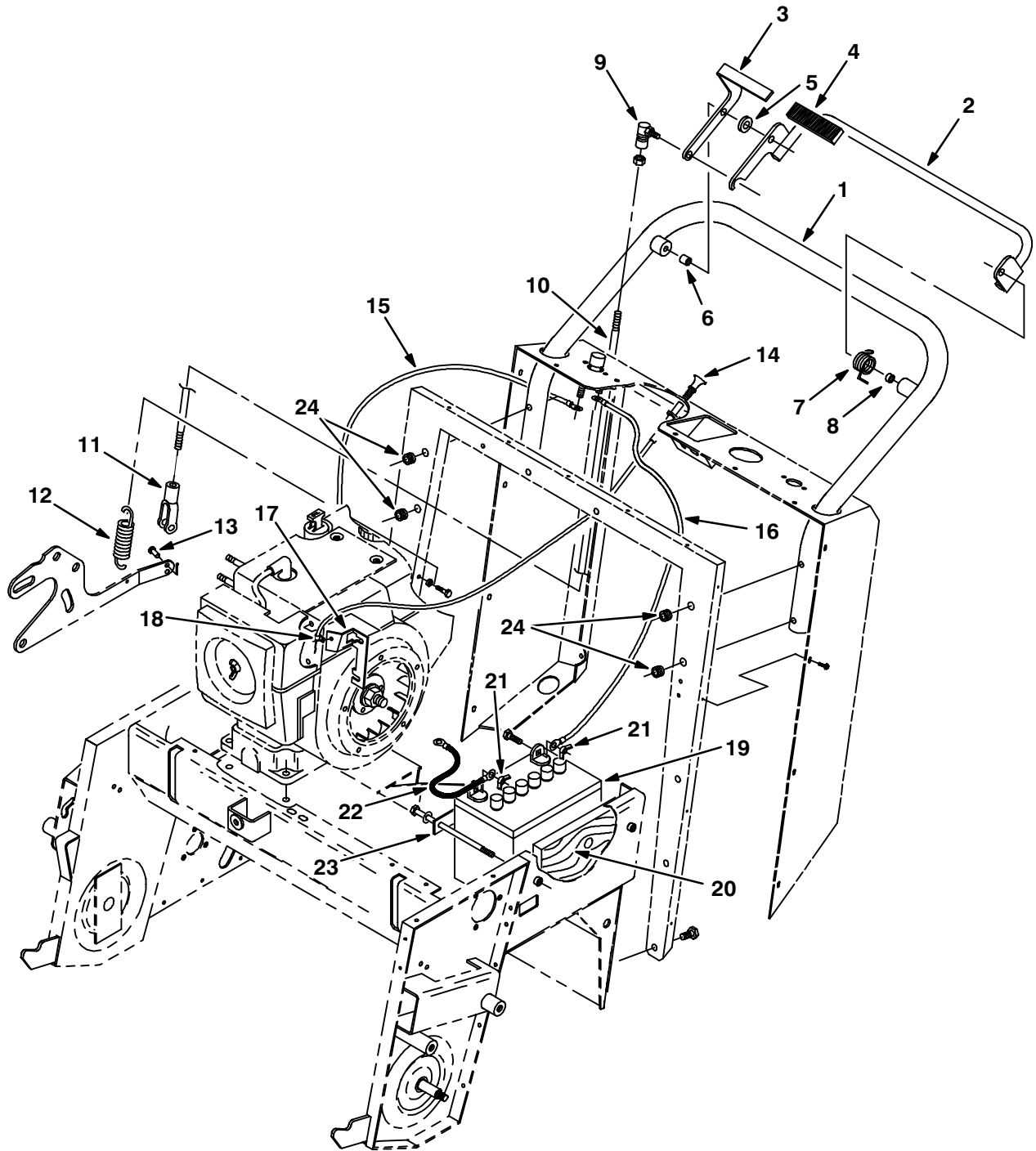

Fig. 6 – Handle and Battery Group

Key	TENNANT Part No.	Machine Serial Number	Description	Qty
1	70316	(006000–008454)	Handle Replacement Kit, Steer	1
1	70314	(008455–)	Handle Wldt, Steer	1
2	09400	(006000–)	Handle Wldt, Forward	1
3	09408	(006000–)	Handle, Reverse	1
4	87246	(006000–)	Grip Vinyl .18 X .75 X 4.00	1
5	52508	(006000–)	Washer–Wavy Spring,#Ww–381–&–8	1
6	50821	(006000–)	Sleeve, .312B .44D .56 Crs	1
7	50910	(006000–)	Spring,Tors,1.06Idx.08Wire, 3T	1
8	50936	(006000–)	Sleeve, .312B .44D .171 Crs	1
9	50909	(006000–)	Balljoint .312–24 Qkdisc	1
10	09473	(006000–008454)	Rod, Control	1
10	70315	(008455–)	Rod, Control	1
11	58311	(006000–)	Adjustable Yoke End, 5/16–24	1
12	29545	(006000–)	Spring, Tens .56Odx.05Wirex1.4	1
13	69582	(006000–)	Pin, Clevis, 0.31 Dix.X1.00 Lg	1
14	08078	(006000–)	Cable, Control	1
15	19979	(006000–)	Cable Assy–Batt, Pos, 20.0	1
16	01365	(006000–)	Wire Assy–Cable 42.0 Lg 4Ga	1
17	01156	(006000–)	Bracket, Choke	1
18	26414	(006000–)	Clamp–Cable, 0.19Dia 0.50Wth	1
19	10134	(006000–)	Battery,12V, Cc Amps:260 Wet	1
19	10135	(006000–)	Battery,12V, Cc Amps:260 Dry	1
20	28973	(006000–)	Pad, Battery	1
21	39270	(006000–)	Nut–Wing .25–20 Pltd	2
22	01366	(006000–)	Wire Assy–Cabl 24.Olg 4Ga Blk	1
23	01136	(006000–)	Strap, Battery	1
24	10632–12	(006000–)	Grommet, Rbr, 0.38ld, For.12Matl	4

Fig. 7 – Engine and Sheaves Group

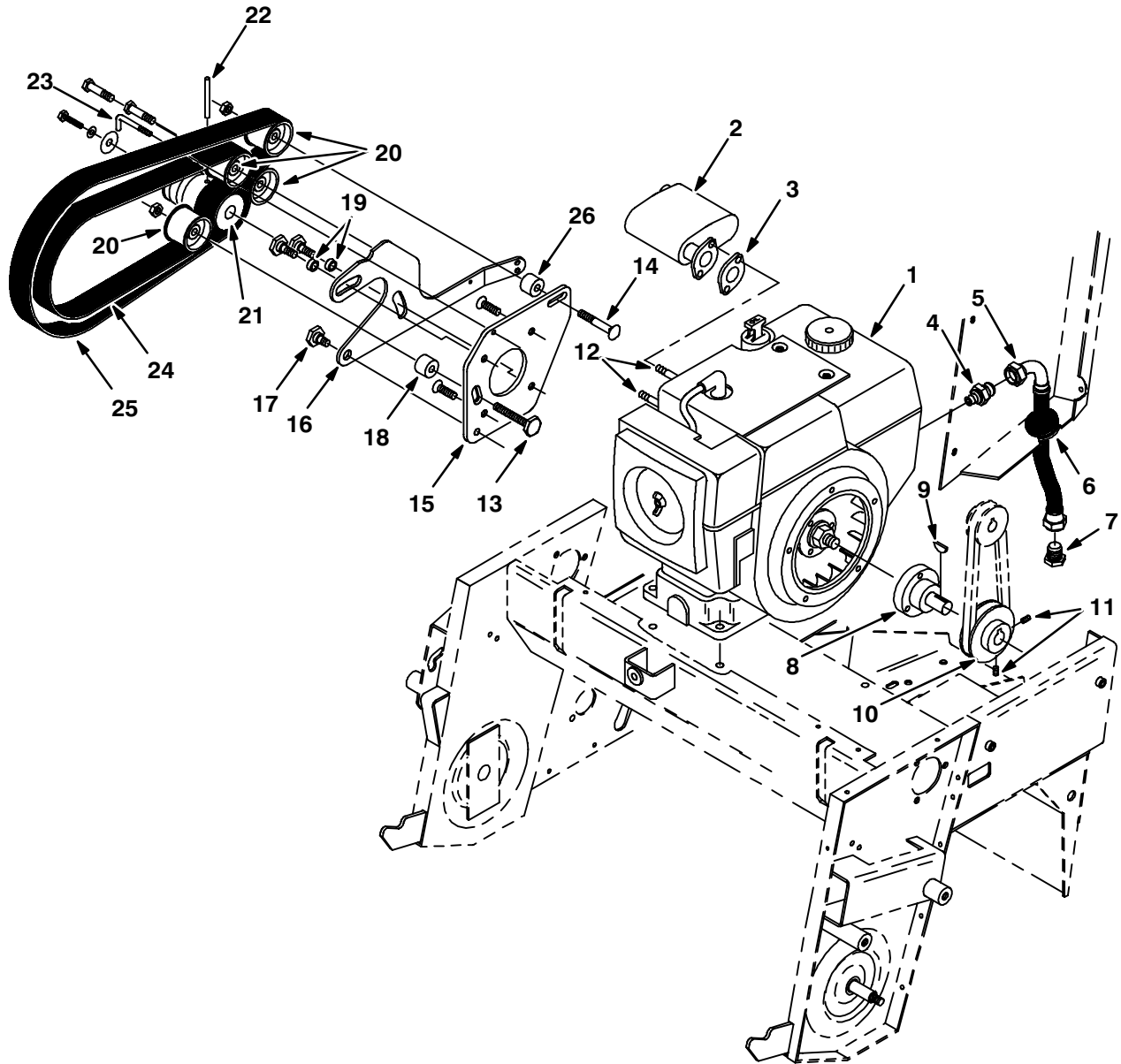

Fig. 7 – Engine and Sheaves Group

Key	TENNANT Part No.	Machine Serial Number	Description	Qty
1	01280	(006000–)	Engine, 8Hp–Gas	1
1	48769	(006000–)	Engine, (California Only)	1
2	01240	(006000–)	Muffler–Exh, Ovl, To 19Cu”Eng	1
3	01089	(006000–)	Gasket, Exhaust	1
4	15687	(006000–)	Ftg–Hyd Str	1
5	55762	(006000–)	Hose–Hyd Low08	1
6	10632–14	(006000–)	Grommet, Rbr,1.00ld, For.12Matl	1
7	16376	(006000–)	Ftg–Hyd Plg	1
8	06664	(006000–)	Shaft, Vac Drive	1
9	00500–6	(006000–)	Key–Wdruff 0.12 0.75 Asa#0406	1
10	01103	(006000–)	Sheave, 3L,1Gr, 2.8Pd	1
11	46820	(006000–)	Scr–Set .31–18X0.38 Nylon Loc	2
12	54396	(006000–)	Scr Hex .31–18X0.75	2
13	30205	(006000–)	Screw, Leveler	1
14	01150	(006000–)	Bolt–Carr.38–16X2.50 G5 Pltd	1
15	25921	(006000–)	Plate, Direct Pivot	1
16	08037	(006000–)	Lever Weldmt, Direction Control	1
17	01112	(006000–)	Screw, Shoulder	1
18	01113	(006000–)	Spacer, Directional Plate	1
19	12955	(006000–)	Sleeve, .375B .56D .22 Stlzn	2
20	01199	(006000–)	Pulley, Idler–Flanged 1.87 Dia	4
21	01115	(006000–)	Sheave, Combination V&Flat	1
22	11398	(006000–)	Pin,Roll, .25Odx2.00L, .250/.256	1
23	01134	(006000–)	Retainer, Belt	1
24	01119	(006000–)	Belt, Flat, 33.50Lg	1
25	01120	(006000–)	Belt, Flat, 38,75Lg	1
26	70326	(006000–)	Spacer, Directional Plate	1

Fig. 8 – Engine and Fuel Tank Group, LPG

Key	TENNANT Part No.	Machine Serial Number	Description	Qty
1	02250	(000000–)	Engine, 8Hp–Lp	1
1	48771	(000000–)	Engine, (California Only)	1
2	22324	(000000–)	Hose Lpg,4Lpg 31In.Lg	2
3	11442–1	(000000–)	Ftg–EI90 Npt/Npt S04Pf–04Pm	2
4	27048	(000000–)	Ftg–EI90 Npt/Npt 04Pf/04Pm	1
▽	5 47935	(000000–)	Regulator,Lp.,Garretson	1
▲	5 37666	(000000–)	Repair Kit	1
▲	6 37673	(000000–)	Gasket Inlet	1
▲	7 37669	(000000–)	Fitting	1
▽	8 53395–4	(000000–004604)	Filter	1
▲	8 SK1444	(000000–004604)	Repair Kit–Filter Fuelock	1
	9 01283	(000000–004604)	Bracket	1
	10 57452	(000000–)	Sleeve–Nyln #16 7.0L	2
	11 26496	(000000–)	Coupling,Quickdisc, Lpg, Shwd	1
	12 10756	(000000–004604)	Hose Lpg,4Lpg 18In.Lg L	1
	13 01189	(000000–005999)	Brace,Center Lp	1
	14 49250	(000000–)	Relay, 12Vdc,Spdt	1
	15 53400–5	(000000–)	Pin Assy, Locating, Lpgtank	1
	16 01262	(000000–)	Brkt Weldmt, Lp Tank Mount	1
▽	17 53400–1	(000000–)	Latch Assy, Lpg Tank Mtg,W/Nut	1
▲	18 53400–4	(000000–)	Nut, Adjustable, Lpg Tank Mtg	1
	19 01314	(000000–)	Plugbtn .38H .03–.12 Blacknyl	1
	20 56390	(000000–)	Grommet,Rbr,1.50Id,For .09Matl	1
▽	21 12985	(000000–005999)	Cover Assy, Rh Lpg	1
▲	22 64757	(000000–005999)	Bumper,Rubber .50Dia	2
▲	23 01335	(000000–005999)	Rivet, Pop–.125Dx.44X.25Dhd Al	4
▲	24 01144	(000000–005999)	Closure, Edge Mating	2
▽	25 06466	(000000–005999)	Cover Assy, Engine, Lh 186Lp	1
▲	26 64757	(000000–005999)	Bumper,Rubber .50Dia	2
▲	27 01335	(000000–005999)	Rivet, Pop–.125Dx.44X.25Dhd Al	4
▲	28 01144	(000000–005999)	Closure, Edge Mating	2
	29 01284	(000000–)	Bracket, Lp Regulator	1
	30 54179	(000000–)	Ftg–Brs E90	1
	31 22308–3	(000000–004604)	Hose, Lpg, 4Lpg X 35.0Lg	1
▽	32 30181	(004605–)	Lock, Lp Fuel	1
▲	32 30182	(004605–)	Repair Kit	1
	33 27048	(000000–004604)	Ftg–EI90 Npt/Npt 04Pf/04Pm	1
	34 09487	(006000–)	Channel Wldt, Center Lp	1
	35 09367	(006000–)	Magnetic Strip, Flex1.0 .06 11	2
▽	36 61064	(006000–)	Cover Assy, Rh 186/1186Lpg	1
▲	37 50832	(006000–)	Hinge, Pull Pin Lh	1
▲	38 50835	(006000–)	Hinge, Pull Pin Rh	1
▲	39 50894	(006000–)	Handle, Cover	1
▲	40 01335	(006000–)	Rivet, Pop. 125Dx.44X.25Dhd Al	10
▲	41 12964	(006000–)	Guard, Muffler	2
▲	42 64757	(006000–)	Bumper, Rubber .50Dia	3
▽	43 61065	(006000–)	Cover Assy, Lh 186/1186Lpg	1
▲	44 50832	(006000–)	Hinge, Pull Pin Lh	1
▲	45 50835	(006000–)	Hinge, Pull Pin Rh	1
▲	46 01335	(006000–)	Rivet, Pop–.125Dx.44X.25Dhd Al	4
▲	47 64757	(006000–)	Bumper,Rubber .50Dia	3

Fig. 9 – Brush Drive Group

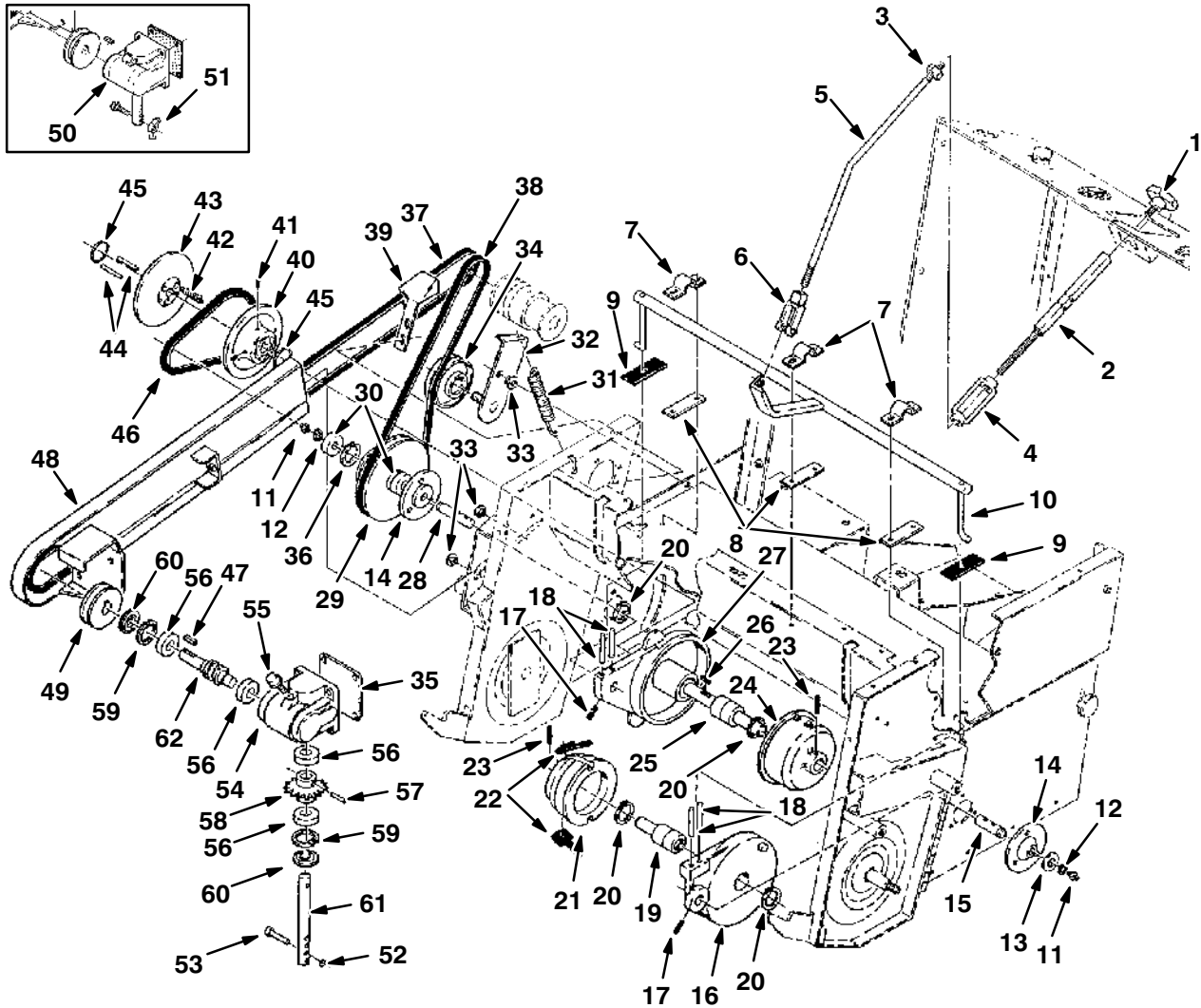

03053

Key	TENNANT Part No.	Machine Serial Number	Description	Qty.
1	01139	(000000–)	Handle, Tee	1
2	01138	(000000–)	Handle, Brush Lift	1
3	39562	(000000–)	Nut, Hex, L.H.	1
4	40352	(000000–)	Turnbuckle	1
5	01141	(000000–)	Rod, Brush Lift	1
6	14330	(000000–)	Yoke, Adjustable	1
7	28074	(000000–)	Clamp, Conduit	3
8	28066	(000000–)	Strip	3
9	29005	(000000–)	Seal	2
10	08147	(000000–)	Shaft, Brush Lift	1
11	07259	(000000–)	Fitting, Grease	2
12	18136	(000000–)	Ring, Retaining	2
13	28862	(000000–)	Washer, Thrust	1
14	01236	(000000–)	Bushing	2
15	28850A	(000000–)	Shaft, Short	1
16	28841	(000000–)	Arm	1
17	26103	(000000–)	Pin, Roll	2

Key	TENNANT Part No.	Machine Serial Number	Description	Qty.	
18	20050	(000000-)	Pin, Roll	4	
19	28868	(000000-)	Bearing and Shaft	1	
20	23217	(000000-)	Ring, Retaining	4	
21	28977	(000000-)	Plug Assembly	1	
22	28852	(000000-)	Finger	2	
23	26239	(000000-)	Pin, Roll	2	
24	28976	(000000-)	Plug and Pin Assembly, Drive	1	
25	28867	(000000-)	Bearing and Shaft	1	
26	00911	(000000-)	Key, Square	1	
27	28840	(000000-)	Arm	1	
28	28849-1	(000000-)	Shaft, Long	1	
29	28845A	(000000-)	Sheave, Step	1	
30	28010	(000000-)	Bearing, Ball	2	
31	26212	(000000-)	Spring, Tension	1	
32	01058	(000000-)	Arm and Shaft Assembly, Idler	1	
33	01047	(000000-)	Retainer	3	
34	28223	(000000-002277)	Pulley Assembly	1	
34	06651	(002278-)	Pulley Assembly	1	
35	28078	(000000-)	Gasket	1	
36	01513	(000000-)	Ring, Retaining	1	
37	28712	(000000-)	V-Belt	1	
38	28714	(000000-)	V-Belt	1	
39	08155	(000000-)	Guide, Belt	1	
▽	28979	(000000-)	Sheave Assembly, Adjustable	1	
▲	40	18125	(000000-)	Sheave Half, Inner	1
▲	41	57496	(000000-)	Screw, Nylon Set	2
▲	42	28387	(000000-)	Spring, Tension	3
▲	43	28949	(000000-)	Sheave Half, Outer	1
▲	44	18276	(000000-)	Pin, Dowel	2
▲	45	28388	(000000-)	Retainer	2
46	28168	(000000-)	V-Belt	1	
47	00911	(000000-)	Key, Square	1	
48	01500	(000000-)	Arm, Side Sweep	1	
49	28121	(000000-)	Sheave	1	
▽	50	94150	(000000-002468)	Gearbox, Reducer (Replaced by 06662)	1
▲	94149	(000000-002468)	Plug, Breather	1	
▲	94413	(000000-002468)	Seal, Oil	2	
51	26509	(000000- xxxxxx)	Nut, Wing	1	
52	49708	(xxxxxx-)	Ring, Split	1	
53	15173	(xxxxxx-)	Pin, Clevis	1	
▽	54	06662	(002469-)	Reducer Assembly	1
▲	55	07316-15	(002469-)	Breather	1
▲	56	28010	(002469-)	Bearing	4
▲	57	28144	(002469-)	Pin, Roll	1
▲	58	28195	(002469-)	Gear	1
▲	59	01513	(002469-)	Ring, Retaining	2
▲	60	28084	(002469-)	Seal, Oil	2
▲	61	28041	(002469-)	Shaft, Reducer	1
▲	62	28194	(002469-)	Worm	1

Fig. 10 – Wheel Drive Group

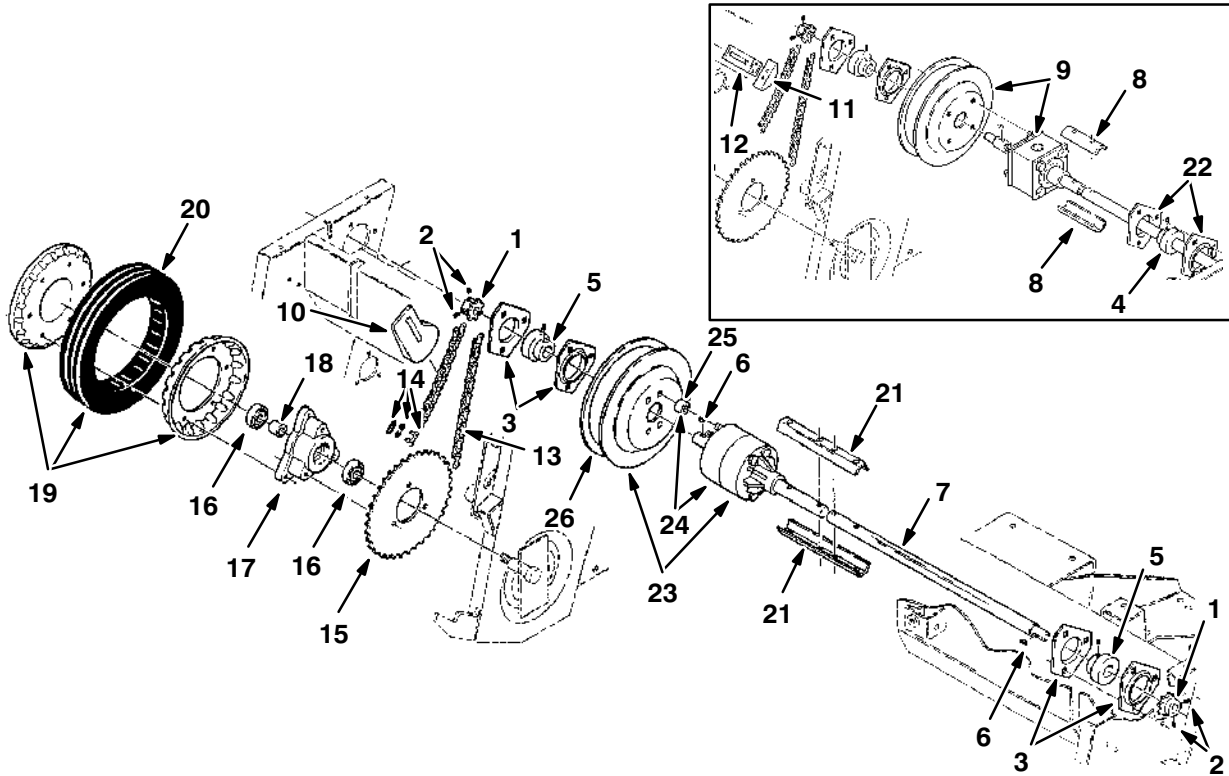

03051

Key	TENNANT Part No.	Machine Serial Number	Description	Qty
1	30175	(000000-004428)	Sprocket Replacment Kit	2
1	30174	(004429-)	Sprocket 8T41	2
2	20634	(000000-004428)	Scr-Set 10-24X0.25 Nylon Loc	4
2	57496	(004429-)	Scr-Set .25-20X0.31 Nylon Loc	4
3	51137	(000000-)	Flange,Brg,3 Hole, Pnt.	4
4	25887	(000000-002566)	Bearing, .750 Bore	1
5	25887	(000000-)	Bearing, .750 Bore	2
6	00500-1	(000000-)	Key-Wdruff 0.09 0.50	2
7	08152	(000000-)	Countershaft	1
8	01362	(000000-002566)	Coupling,Half	2
9	12990	(000000-003551)	Differential Asy	1
10	08142	(003552-)	Chain Guide	2
11	01217	(000000-003551)	Guide	2
12	01200	(000000-003551)	Tightener	2
∇ 13	61414	(000000-)	Chain and Link Assembly	2
▲ 14	28272	(000000-)	Link, Rlr.Chain #41	2
15	28865	(000000-)	Sprkt,#41, 45T Plate Sprocket	2
16	28010	(000000-)	Bearing-Ball,0.62B 1.38D 0.43W	4
17	01288	(000000-)	Hub, Wheel-Machined	2
18	28014A	(000000-)	Sleeve, .657B .88D .630Cr.Cad	2
∇ 19	28061	(000000-)	Wheel & Tire Assy	2
▲ 20	28546	(000000-)	Tire,10X2.00 Ehs Semi-Pneu.	1
21	08145	(002567-)	Coupling,Half	2
22	51137	(000000-002566)	Flange, Brg, 3 Hole, Pnt.	2
∇ 23	30148	(003552-)	Differential & Sheave Assy	1
▲∇ 24	61291	(003552-)	Rplmt Kit, Differential F/12960	1
▲▲ 25	61289	(003552-)	Sleeve	4
▲ 26	30147	(003552-)	Sheave, Flat Belt	1

Fig. 11 – Hopper Group

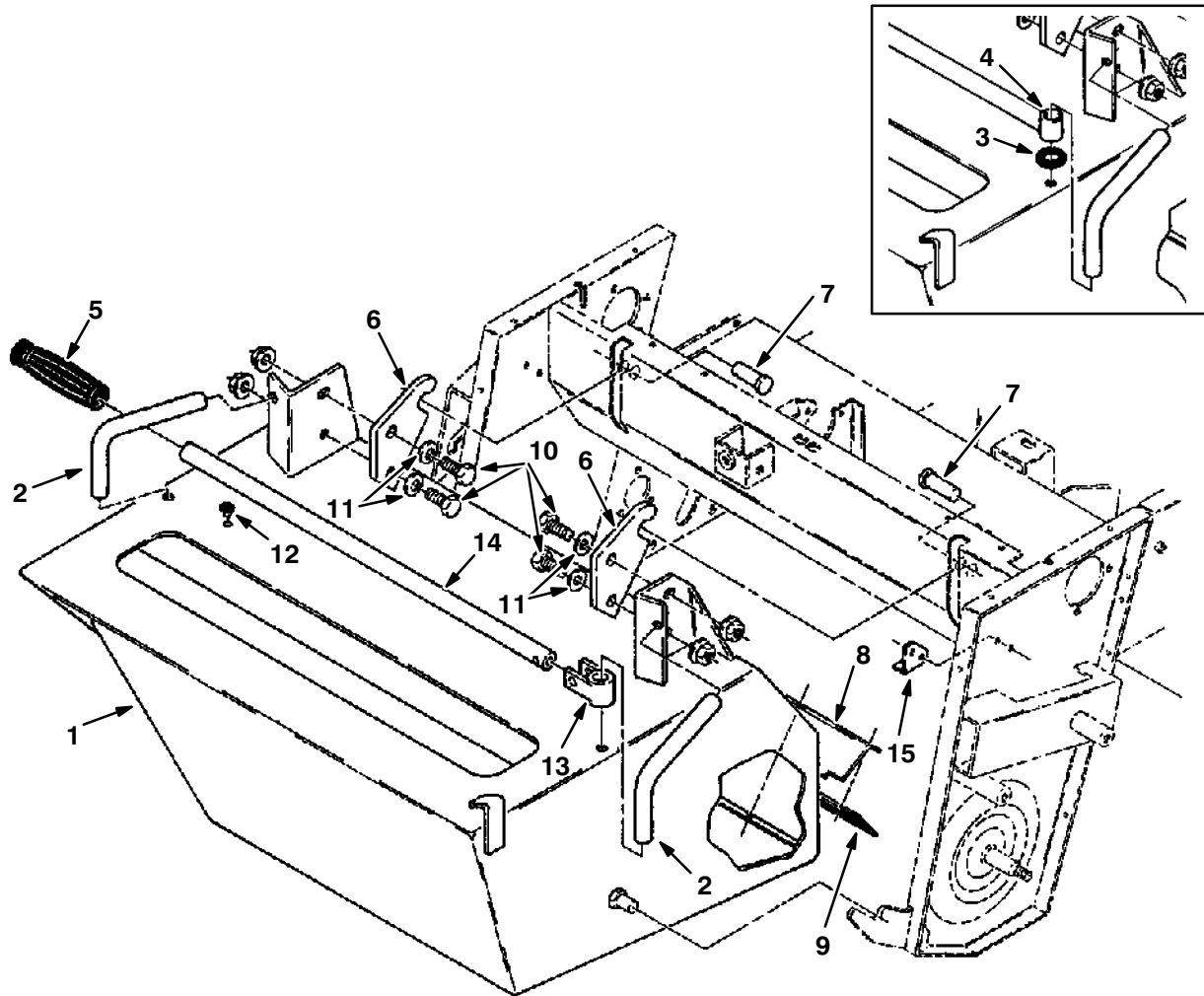

03048

Key	TENNANT Part No.	Machine Serial Number	Description	Qty.
1	01121	(000000-)	Hopper	1
2	01157	(000000-)	Handle, Hopper Lift	2
3	01316	(000000-003453)	Washer, Rubber	1
4	12764	(000000-003453)	Handle Lift Replacement Kit	1
5	03292B	(000000-)	Grip, Handle	1
6	01132	(000000-)	Plate, Hopper Catch	2
7	01272	(000000-)	Pin, Clevis	2
8	31025	(000000-)	Retainer, Lip	1
9	28081	(000000-)	Lip Assembly, Pan	1
10	41620	(000000-)	Screw, Hex, G8	4
11	41186	(000000-)	Washer, Belleville	4
12	51787	(000000-)	Bumper, Rubber	1
13	12768	(003454-)	Knuckle, Handle	1
14	12769	(003454-)	Handle, Lift	1
15	61123	(000000-)	Stop, Angle	1

Fig. 12 – Vacuum Fan Group

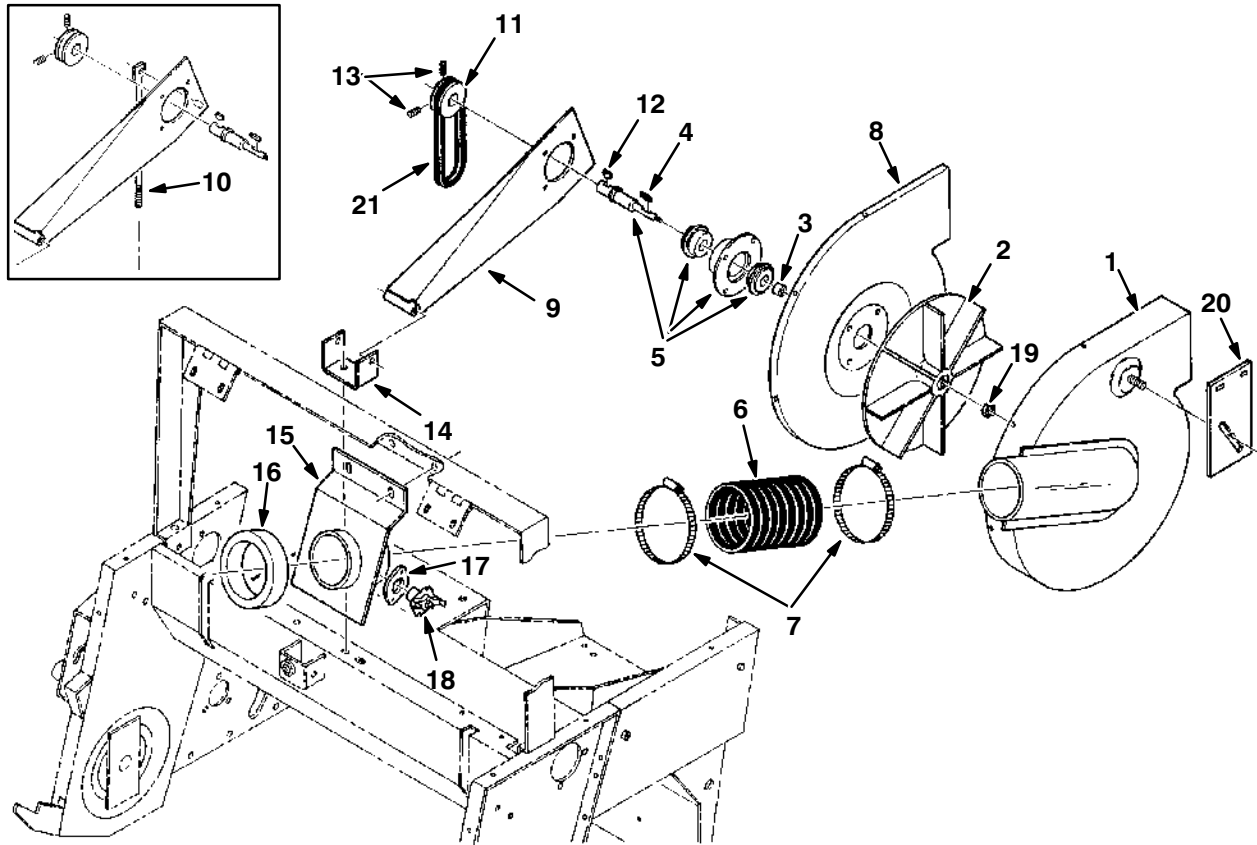

03057

Key	TENNANT Part No.	Machine Serial Number	Description	Qty.
1	10352	(000000–)	Housing, Vacuum Fan	1
2	08143	(000000–)	Impeller	1
3	10362	(000000–)	Sleeve	1
4	00960	(000000–)	Key, Square	1
5	16934	(000000–)	Shaft, Bearing and Flange Assembly	1
6	23481	(000000–)	Hose	1
7	23498	(000000–)	Clamp, Worm Drive	2
8	02221	(000000–)	Plate, Housing Backing	1
9	01188	(000000–)	Arm, Fan Mount	1
10	01255	(000000–002252)	Rod, Adjustment	1
11	01104	(000000–)	Sheave	1
12	00500–4	(000000–)	Key, Woodruff	1
13	46820	(000000–)	Screw, Nylon Set	2
14	01096	(000000–)	Bracket, Fan Pivot	1
15	41292	(000000–)	Adaptor, Filter To Fan	1
16	47069	(000000–)	Sleeve	1
17	82733	(000000–)	Gasket, Thermostat	1
18	87546	(000000–)	Thermostat, Sealed	1
19	87299	(000000–)	Nut, Flex Lock	1
20	10224	(002253–)	Plate, Backing	1
21	28755	(000000–005999)	V-Belt	1
21	60470	(006000–)	V-Belt	1

Fig. 13 – Filter and Shaker Motor Group

Thumb Screws are part no. 39778

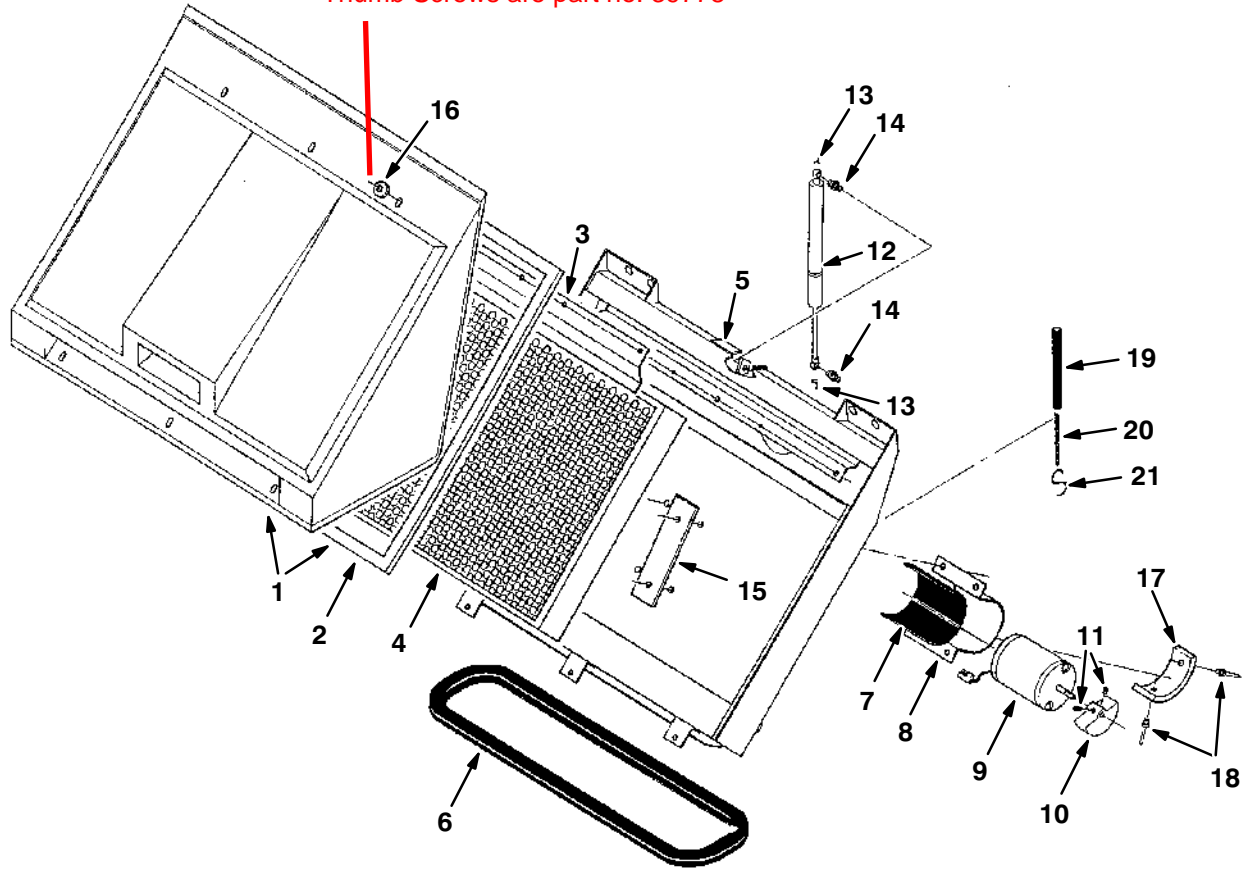

03056

Key	TENNANT Part No.	Machine Serial Number	Description	Qty.
▽ 1	06477	(000000–)	Cover, Filter Assembly	1
▲ 2	01064	(000000–)	Seal, Cover	1
3	01306	(000000–)	Bracket, Hold Down	1
▽ 4	87550	(000000–)	Filter Assembly	1
▲	65375	(000000–)	Gasket	1
5	41288	(000000–)	Box and Label Assembly, Filter	1
6	08157	(000000–)	Seal, Filter Opening	1
7	44893	(000000–)	Pad, Rubber	1
8	06659	(000000–)	Strap, Shaker Motor	1
9	54121	(000000–)	Motor, Electric	1
10	55130	(000000–)	Weight, Eccentric	1
11	20634	(000000–)	Screw, Nylon Set	2
12	31173	(000000–004143)	Spring, Gas	1
12	31172	(004144–)	Spring, Gas	1
13	64595	(000000–)	Clip, Safety	2
14	58494	(000000–)	Stud, Spring Ball	2
15	25920	(000000–)	Plate, Support Shaker	1
16	30169	(000000–)	Washer, Sealing	6
17	06660	(000000–)	Bumper, Shaker	1
18	01335	(000000–)	Rivet, Pop	2
19	01320	(000000–)	Sleeve, Vinyl	1
20	06121	(000000–)	Chain	1
21	01319	(000000–)	Hook, S	1

Fig. 14 – Instrument Panel Group

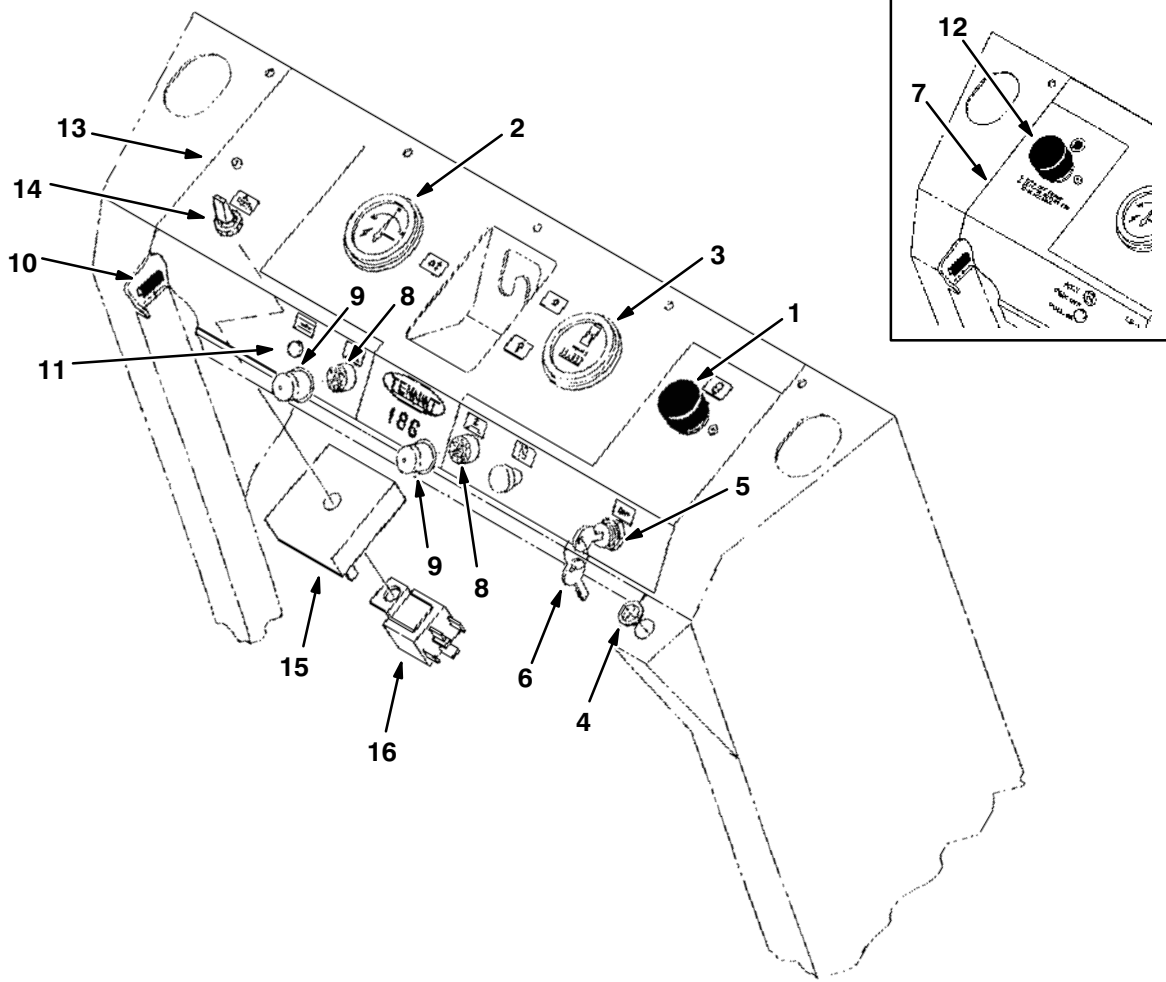

03044

Key	TENNANT Part No.	Machine Serial Number	Description	Qty.
1	44078	(000000-005999)	Switch, Push	1
2	01364	(000000-005999)	Ammeter	1
3	34810	(000000-005999)	Meter, Hour	1
4	29991	(000000-005999)	Bushing, Nylon Flange	1
▽ 5	33285	(000000-005999)	Switch Assembly, Key	1
▲ 6	31204	(000000-005999)	Key, Switch	1
7	12774	(000000-004368)	Label, Instrument Panel	1
8	57803	(000000-005999)	Breaker, Circuit	2
9	57751	(000000-005999)	Boot, Circuit Breaker	2
10	59118-7	(000000-005999)	Molding, Rigid	1
11	01314	(000000-005999)	Plugbutton	1
12	44078	(000000-004368)	Switch, Push	1
13	09362	(004369-005999)	Label, Instrument Panel	1
14	63266	(004369-005999)	Switch	1
15	09338	(004369-005999)	Timer, Shaker	1
16	64730	(004369-005999)	Relay, SPDT	1

Fig. 15 – Instrument Panel Group

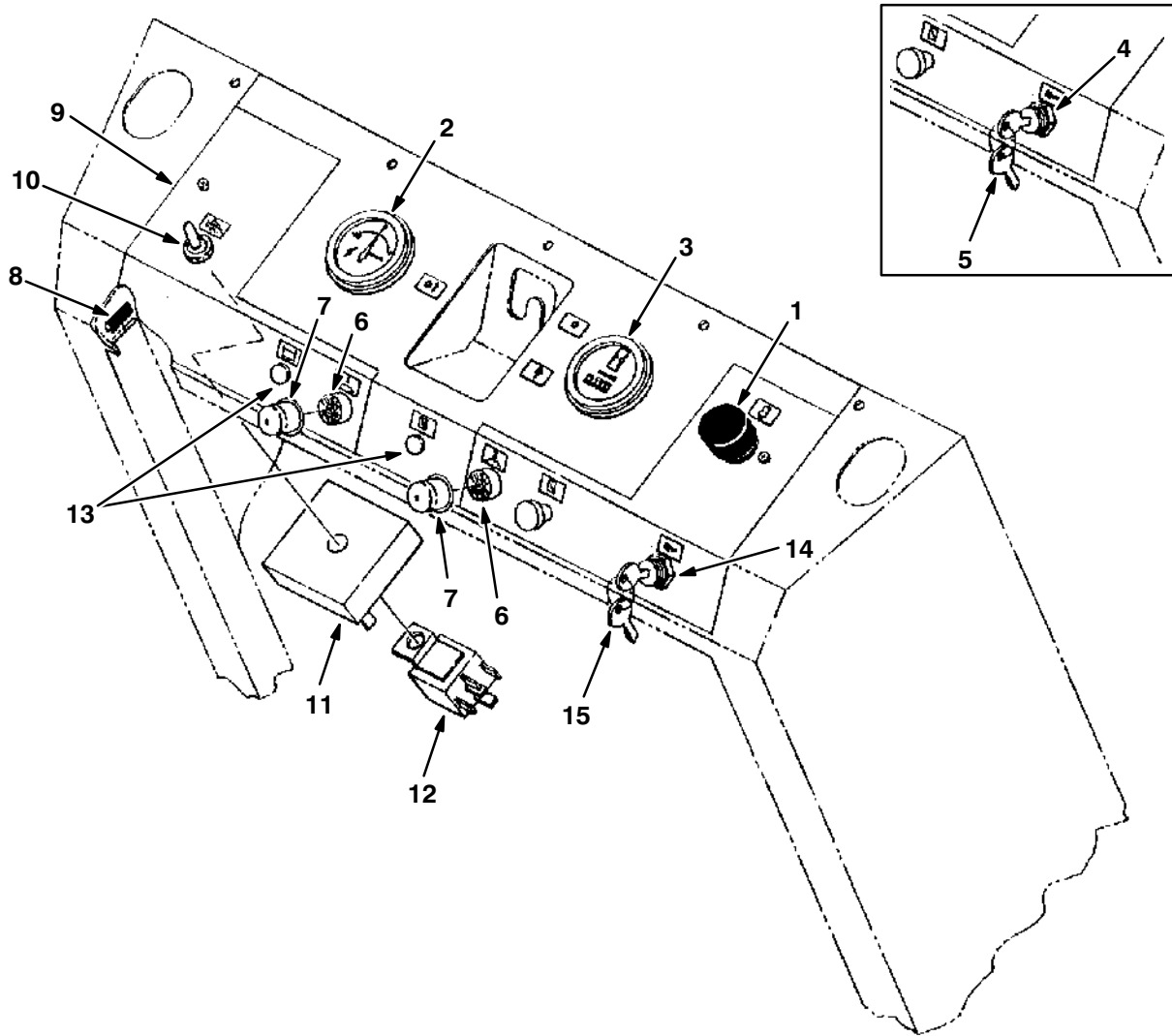

06431

Key	TENNANT Part No.	Machine Serial Number	Description	Qty.
1	44078	(006000-)	Switch, Push	1
2	01364	(006000-)	Ammeter	1
3	34810	(006000-)	Meter, Hour	1
▽ 4	33285	(006000-009218)	Switch Assembly, Key	1
▲ 5	31204	(006000-009218)	Key, Switch	1
6	57803	(006000-)	Breaker, Circuit	2
7	57751	(006000-)	Boot, Circuit Breaker	2
8	59118-7	(006000-)	Molding, Rigid	1
9	50829	(006000-)	Label, Instrument Panel	1
10	70320	(006000-)	Switch	1
11	09338	(006000-)	Timer, Shaker	1
12	64730	(006000-)	Relay, SPDT	1
13	01314	(006000-)	Plugbutton	2
▽ 14	70323	(009219-)	Switch Assembly, Key	1
▲ 15	21570	(009219-)	Key, Switch	1

**Fig. 16 – Wire Harnesses Group, Gasoline
(For machine below serial number 003181)**

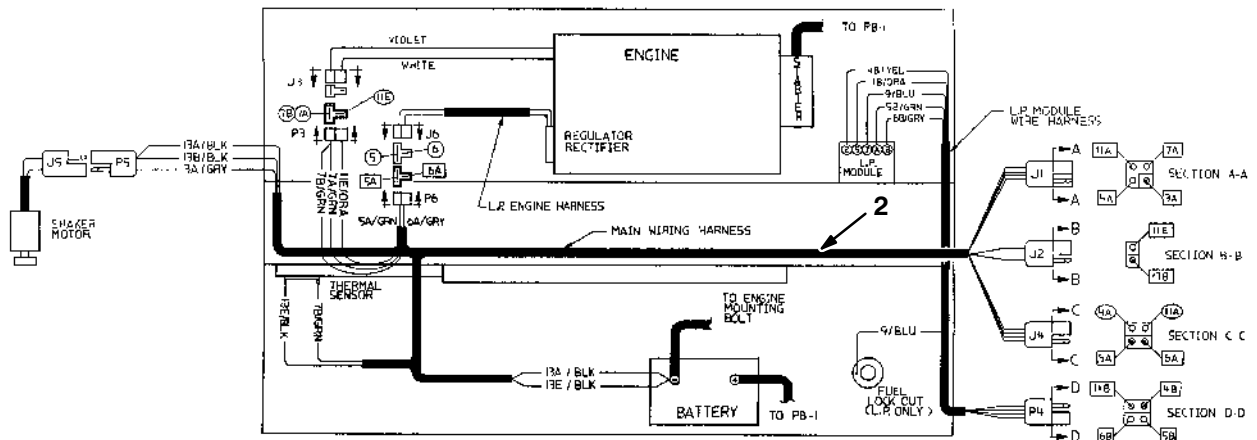

REAR VIEW OF INSTRUMENT PANEL

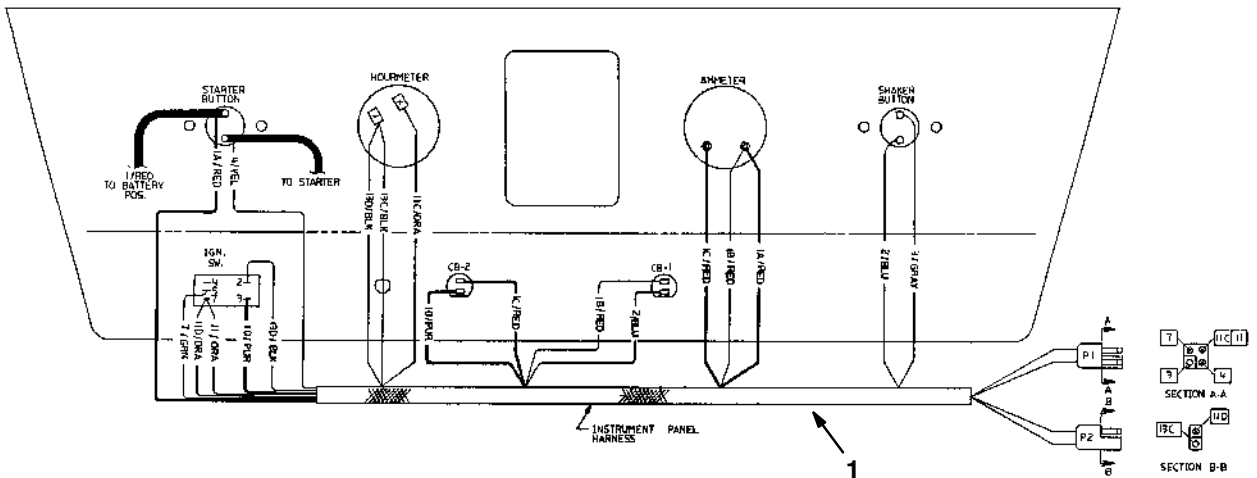
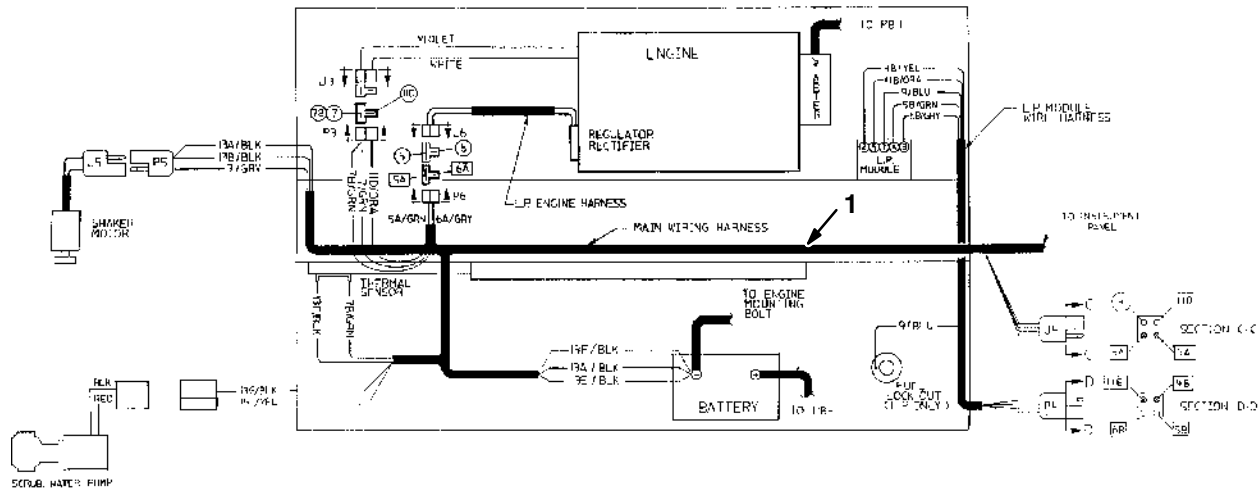
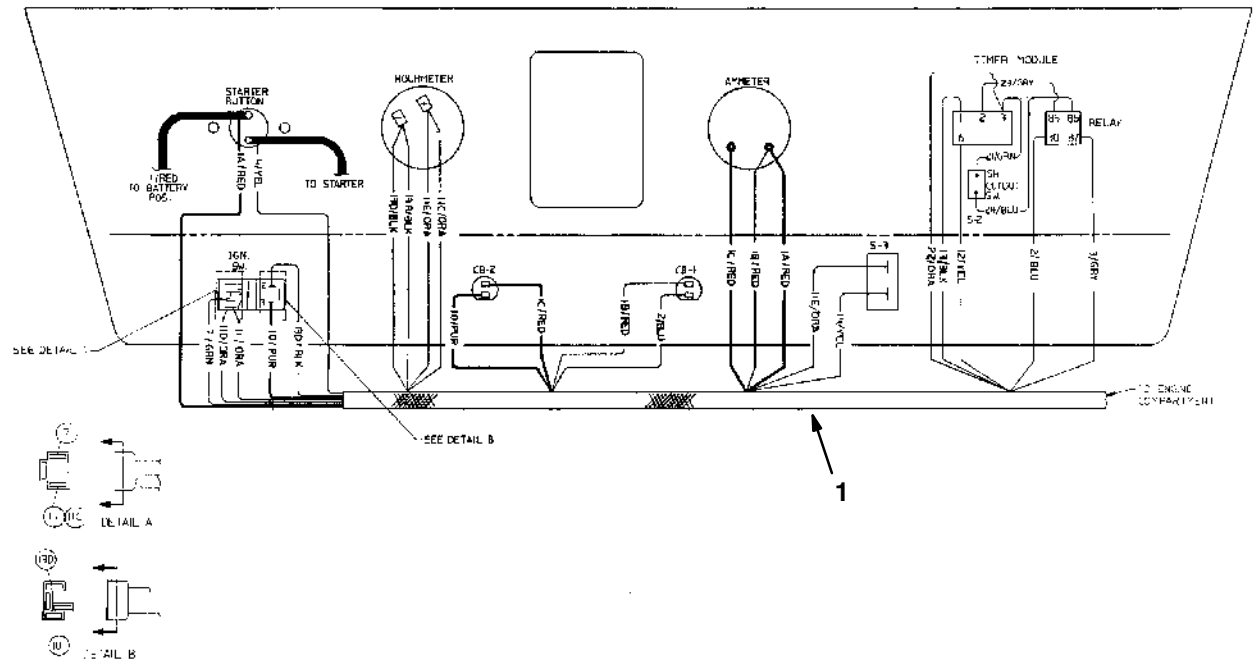

Fig. 17 – Wire Harnesses Group, Gasoline



REAR VIEW OF INSTRUMENT PANEL



Key	TENNANT Part No.	Machine Serial Number	Description	Qty.
1	50806	(006000–)	Wire Harness, Complete	1

06435

Fig. 18 – Label Group

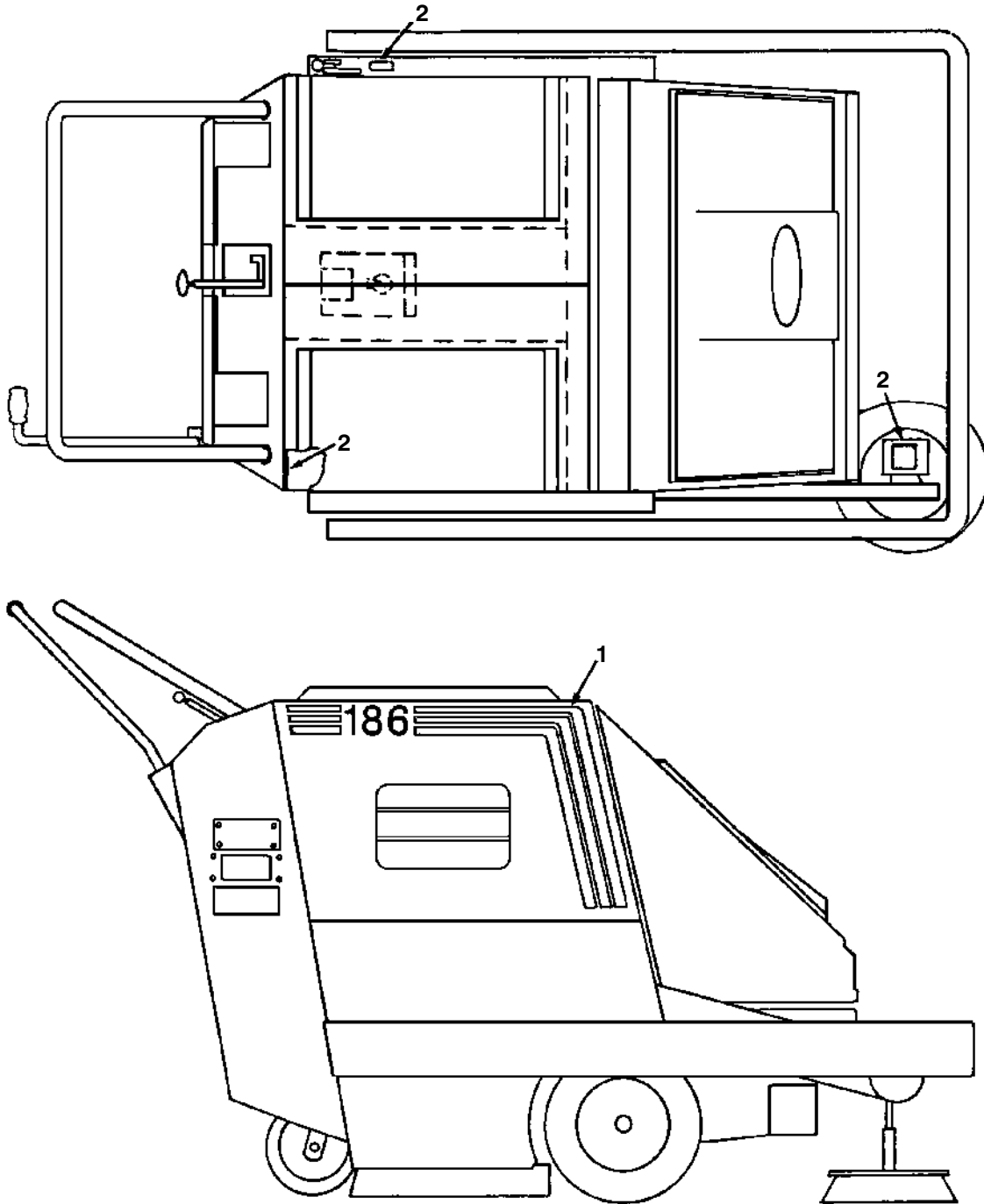

03101

Key	TENNANT Part No.	Machine Serial Number	Description	Qty.
1	30172	(000000–005999)	Label Kit, Striping	1
2	10231	(000000–005999)	Label Kit, Information and Hazard	1

Fig. 19 – Label Group

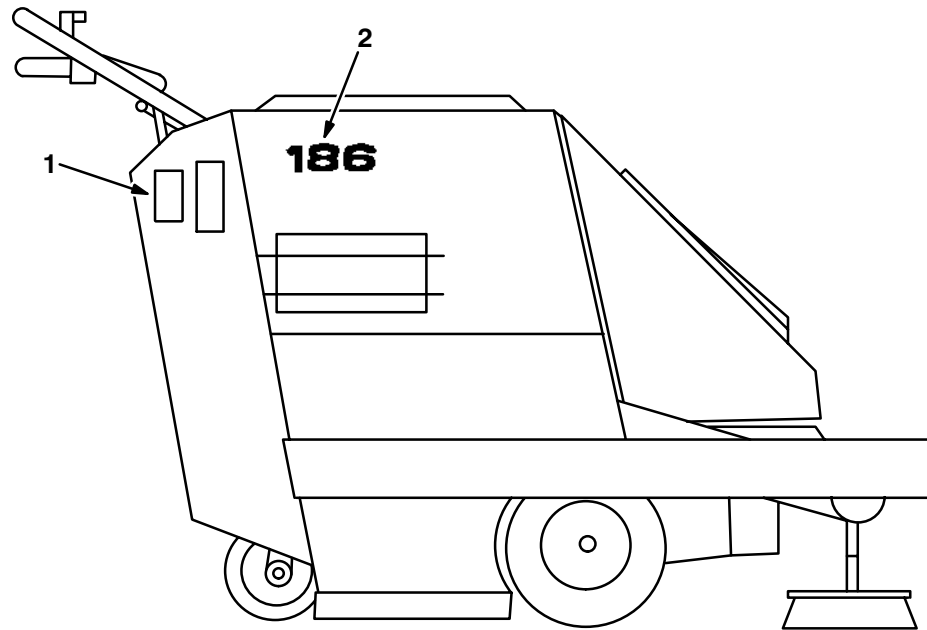
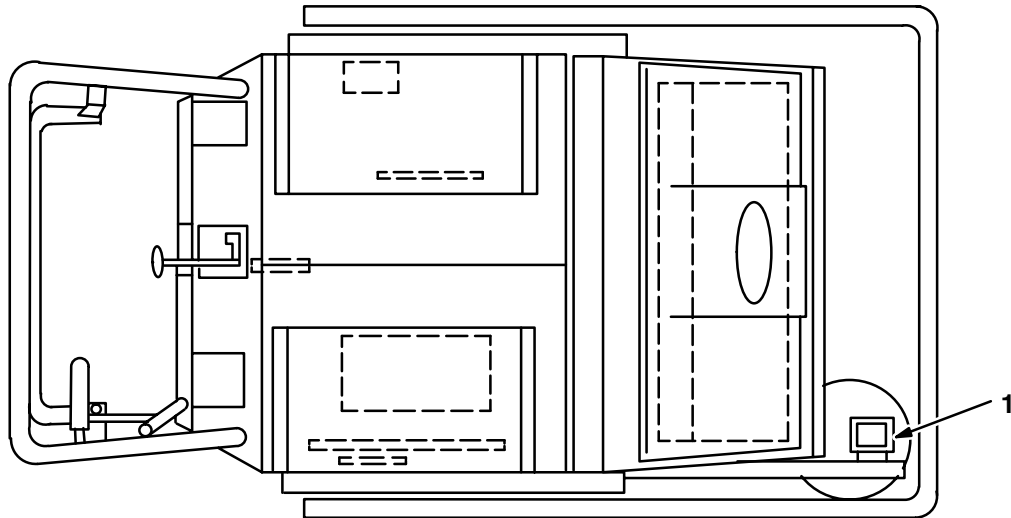

06433

Key	TENNANT Part No.	Machine Serial Number	Description	Qty.
1	50913	(006000–)	Label Kit, Information and Hazard	1
2	50843 30177	(006000–)	Label, 186	1

SECTION 7

CONTENTS

	Page
Fig. 1 – Solution Tank Group	7-2
Fig. 2 – Recovery Tank Group	7-4
Fig. 3 – Rear Squeegee Lift Group	7-6
Fig. 4 – Rear Squeegee Group	7-8
Fig. 5 – Side Scrub Brush Group	7-9
Fig. 6 – Vacuum Fan Deflector and Hose Group	7-10
Fig. 7 – Vacuum Fan Shutoff Group	7-11
Fig. 8 – Recovery Tank Group, Water Pickup	7-12
Fig. 9 – Prep For Scrub and Wand Kit	7-14
Fig. 10 – Vacuum Wand Group	7-15
Fig. 11 – Vacuum Wand Control Group	7-16
Fig. 12 – Vacuum Wand Group	7-17
Fig. 13 – Vacuum Wand Control Group	7-18
Fig. 14 – Filter Bypass Kit	7-19
Fig. 15 – Fine Particle Filter Kit	7-20
Fig. 16 – Lift and Tie-Down Kit	7-21
Fig. 17 – Lift and Tie-Down Kit	7-22
Fig. 18 – Parking Brake Kit	7-23
Fig. 19 – Parking Brake Kit	7-24
Fig. 20 – Dual Caster Group	7-25
Fig. 21 – Fire Extinguisher Kit	7-26
Fig. 22 – Fuel Tank Group, LPG	7-27
Fig. 23 – Double Wheel Kit	7-28
Fig. 24 – Plastic Hopper Kit	7-29
Fig. 25 – Documentation Group	7-30

Fig. 1 – Solution Tank Group

NOTE: Scrubber Attachment Kit, TENNANT Part Number 01027, Includes Fig. 1, 2, 3, 4, 5, and 6.

Key	TENNANT Part No.	Machine Serial Number	Description	Qty.
1	28574	(000000–)	Knob	1
2	01504	(000000–)	Cover, Soap Basket	1
3	43516A	(000000–)	Basket, Soap	1
4	01576	(000000–)	Handle	2
5	01342	(000000–)	Hinge, Tank	2
6	01285	(000000–)	Tank, Solution	1
7	01568	(000000–)	Decal, Scrubber	1
8	01579	(000000–002470)	Support, Tray	1
9	01584	(000000–)	Guide, Tube	1
10	01570	(000000–)	Chain, Jack	1
11	01495	(000000–)	Plug, Expandable	1
12	01622	(000000–)	Fitting, Plug	1
13	01621	(000000–)	Tube, Spreader	1
14	01644	(000000–)	Fitting, Barbed Straight	1
15	01643	(000000–)	Hose, Vinyl	1
16	06478	(000000–)	Fitting, Barbed Elbow	1
17	12053	(000000–002802)	Valve Replacement Kit, Water	1
18	01642	(000000–)	Fitting, Nipple	1
19	01343	(000000–002802)	Bracket, Valve	1
20	43242	(000000–)	Swivel	1
21	06645	(000000–002802)	Arm Replacement Kit, Valve	1
22	06620	(000000–)	Carriage, Solution Tank	1
▽ 23	10387	(000000–)	Tray Assembly, Debris	1
▲ 24	10383	(002471–)	Pan, Debris	1
▲ 25	06654	(002471–)	Support, Tray	1
▲ 26	01580	(000000–)	Wheel, Rubber	2
27	46236	(000000–)	Clamp, Cable	1
▽ 28	01329	(000000–)	Cable, Water Control	1
▲	08067	(000000–)	Cable, Internal	2
29	06800	(000000–)	Decal, Warning, Detergent	1
30	06615	(000000–002470)	Replacement Kit, Axle	2
31	60595	(002803–)	Valve, Water	1
32	12078	(002803–)	Bracket, Valve	1
33	12081	(002803–)	Arm, Valve	1

Fig. 2 – Recovery Tank Group

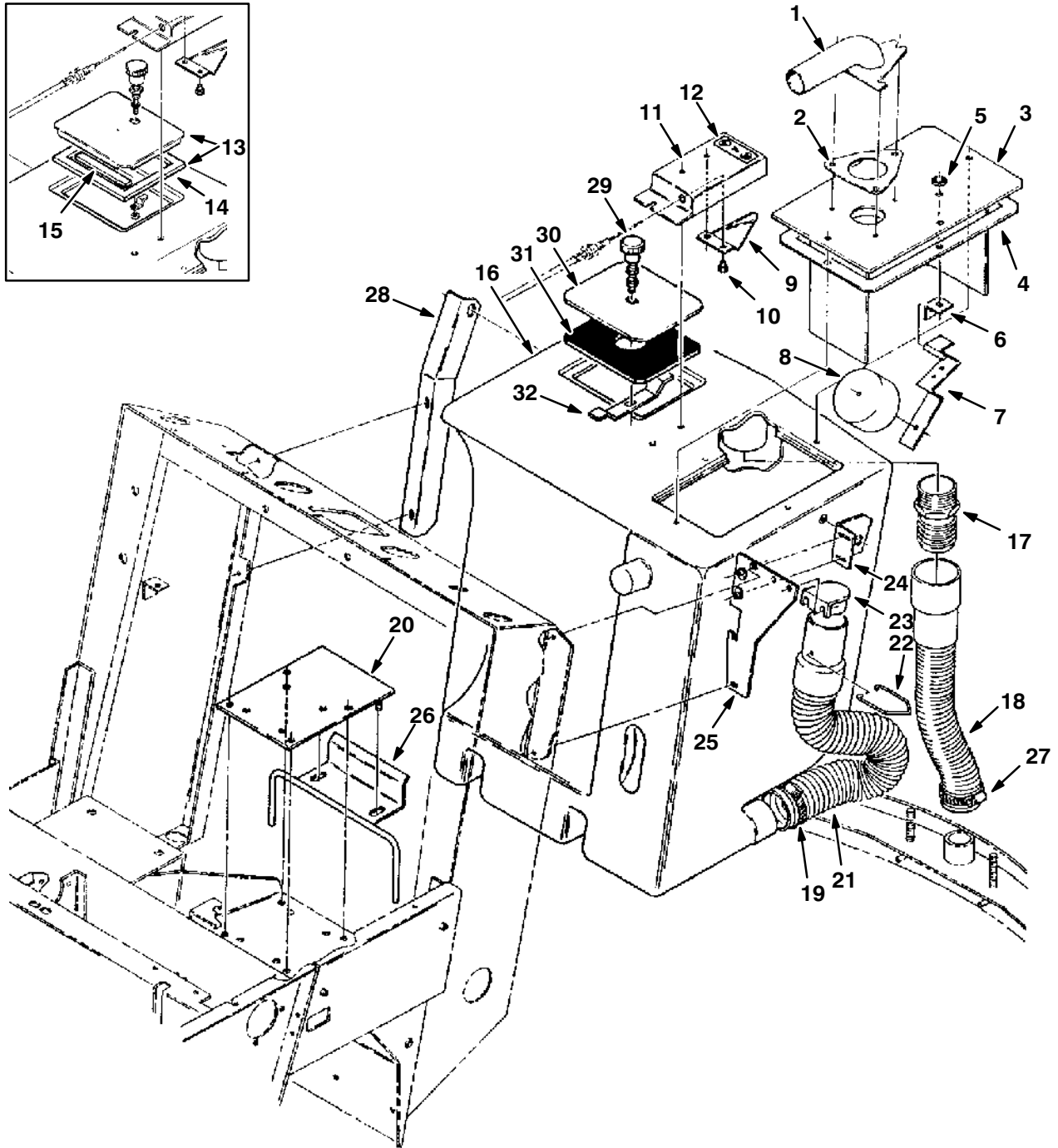

Fig. 2 – Recovery Tank Group

NOTE: Scrubber Attachment Kit, TENNANT Part Number 01027, Includes Fig. 1, 2, 3, 4, 5, and 6.

Key	TENNANT Part No.	Machine Serial Number	Description	Qty.
1	01520	(000000–)	Tube	1
2	29664	(000000–)	Gasket	1
3	01525	(000000–)	Plate, Float	1
4	01640	(000000–)	Gasket, Float Plate	1
5	76426	(000000–002670)	Washer, Sealing	2
5	76426	(002671–)	Washer, Sealing	1
6	63310	(000000–002670)	Bracket, L	2
6	63310	(002671–)	Bracket, L	1
7	45938–1	(000000–)	Bracket, Float Mounting	1
8	45937	(000000–)	Float, Vacuum Fan	1
9	01628	(000000–002802)	Lever, Water Control	1
9	12077	(002803–)	Lever, Water Control	1
10	43242	(000000–)	Swivel	1
11	01633	(000000–002802)	Mount, Valve Lever	1
11	12075	(002803–)	Mount, Valve Lever	1
12	06796	(000000–)	Decal, Solution Control	1
▽ 13	06762	(000000–002216)	Cover Assembly, Tank (Replaced by 10218)	1
▲ 14	28950–2	(000000–002216)	Seal, Foam Rubber	1
▲ 15	49351–3	(000000–002216)	Seal, Foam Rubber	1
16	01286	(000000–)	Tank, Recovery	1
17	01639	(000000–)	Fitting, Barbed Straight	1
18	01536	(000000–)	Hose, Squeegee	1
19	22297	(000000–)	Clamp, Worm Drive	1
20	01413	(000000–)	Support, Tank	1
21	30246	(000000–)	Hose, Drain	1
22	20267	(000000–)	Clip, Retainer	1
23	20215	(000000–)	Plug	1
24	01494	(000000–)	Bracket, Tie Down, L.H.	1
25	01499	(000000–)	Bracket, Pickup Handle	1
26	01534	(000000–)	Retainer	1
27	11531	(000000–)	Clamp, Worm Drive	1
28	01492	(000000–)	Bracket, Tie Down, R.H.	1
▽ 29	10218	(002217–)	Cover and Seal Assembly, Recovery Tank	1
▲ 29	87337	(000000–)	Latch, Door	1
▲ 30	08091	(002217–)	Cover, Recovery Tank	1
▲ 31	08092	(002217–)	Gasket, Cover	1
▲ 32	08093	(002217–)	Pawl, Latch	1

Fig. 3 – Rear Squeegee Lift Group

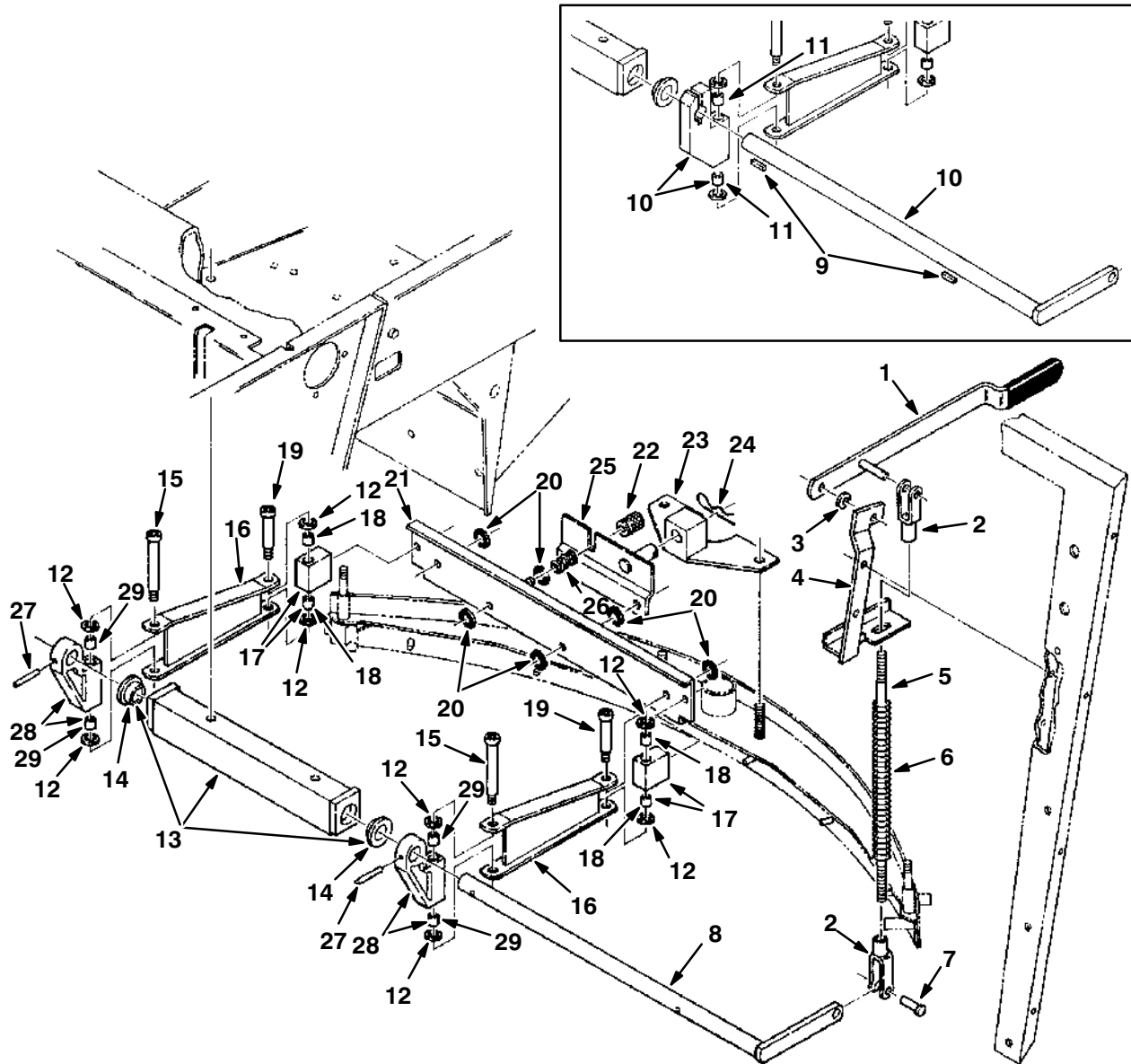
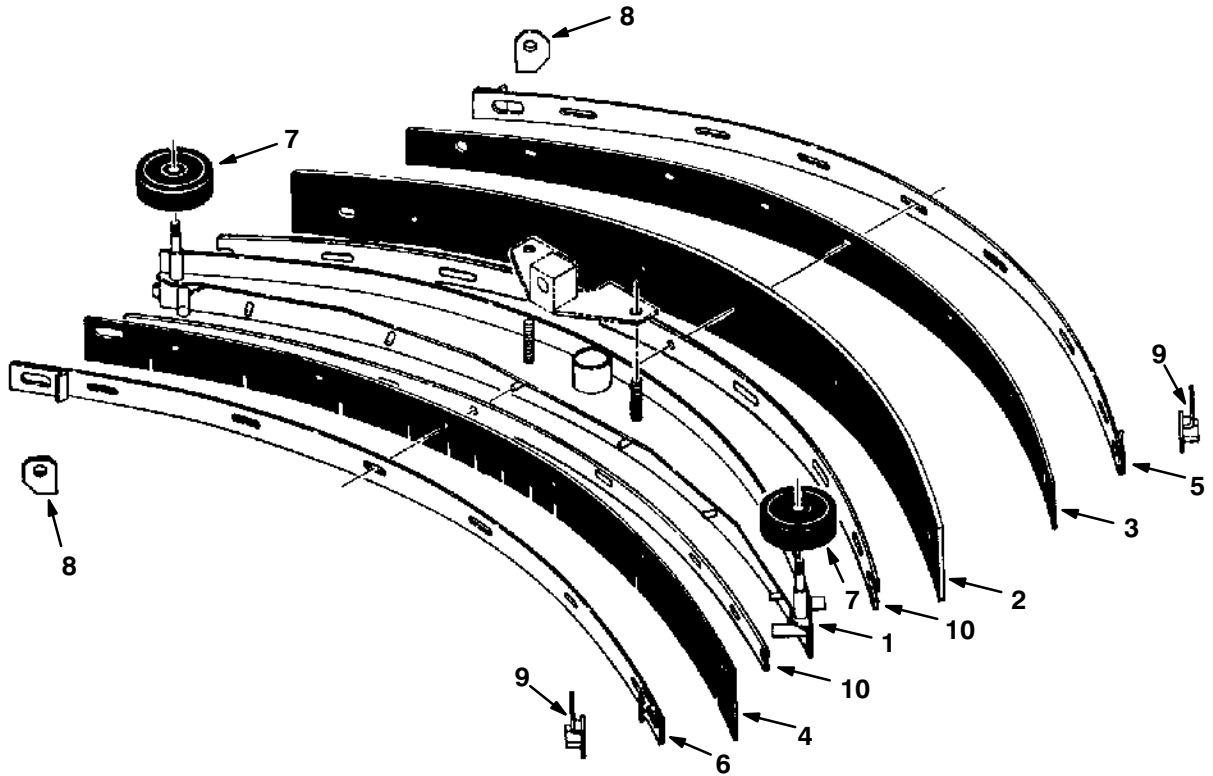

Fig. 3 – Rear Squeegee Lift Group

*NOTE: Scrubber Attachment Kit, TENNANT Part Number 01027, Includes Fig. 1, 2, 3, 4, 5, and 6.
Water Pickup Kit, TENNANT Part Number 08070, Includes Fig. 3, 4, 7, and 8.*

Key	TENNANT Part No.	Machine Serial Number	Description	Qty.
1	01559	(000000–)	Handle, Squeegee Lift	1
2	14330	(000000–)	Yoke, Adjustable	2
3	43454	(000000–)	Washer, Nylon	1
4	01498	(000000–)	Bracket, Pivot	1
5	01344	(000000–)	Rod, Squeegee Lift	1
6	75774	(000000–)	Spring, Compression	1
7	14331	(000000–)	Pin, Clevis	1
8	10361	(002686–)	Shaft, Squeegee Lift	1
9	00911	(000000–002685)	Key, Square	2
▽ 10	06619	(000000–002685)	Squeegee Hinge Replacement Kit	1
▲ 11	01511	(000000–002685)	Bearing, Sleeve	2
12	43611	(000000–)	Washer, Nylon	8
▽ 13	01517	(000000–)	Bar Assembly, Pivot	1
▲ 14	01334	(000000–)	Bearing, Flange	2
15	01507	(000000–)	Screw, Shoulder	2
16	01532	(000000–)	Link, Squeegee	2
▽ 17	01510	(000000–)	Block Assembly, Hinge	2
▲ 18	01511	(000000–)	Bearing, Sleeve	2
19	01508	(000000–)	Screw, Shoulder	2
20	45089	(000000–)	Washer, Rubber	6
21	01347	(000000–)	Rail, Squeegee	1
22	45086	(000000–)	Knob, Adjustment	1
23	01555	(000000–)	Mount, Squeegee	1
24	44906	(000000–)	Pin, Hair Cotter	1
25	01345	(000000–)	Plate, Pivot	1
26	57889	(000000–)	Spring, Compression	1
27	26239	(002686–)	Pin, Roll	2
▽ 28	10386	(002686–)	Hinge Assembly, Arm	2
▲ 29	01511	(002686–)	Bearing, Sleeve	2

Fig. 4 – Rear Squeegee Group



03105

*NOTE: Scrubber Attachment Kit, TENNANT Part Number 01027, Includes Fig. 1, 2, 3, 4, 5, and 6.
Water Pickup Kit, TENNANT Part Number 08070, Includes Fig. 3, 4, 7, and 8.*

Key	TENNANT Part No.	Machine Serial Number	Description	Qty.
▽	01636	(000000–)	Squeegee Assembly	1
▲ 1	01502	(000000–)	Frame, Squeegee	1
▲▽	01780	(000000–)	Performance Package, Squeegee	1
▲▲ 2	03856	(000000–)	Blade, Squeegee	1
▲▲ 3	01657	(000000–)	Strip, Rear Backup	1
▲▲ 4	63967	(000000–)	Blade, Squeegee	1
▲▲ 5	63034	(000000–)	Band, Rear	1
▲▲ 6	63038	(000000–)	Band, Front	1
▲▲ 7	29653	(000000–)	Wheel, Solid	2
▲▲ 8	63327	(000000–)	Cam	2
▲▲ 9	63329	(000000–)	Cam	2
▲▲ 10	06481	(000000–)	Strip, Abrasive	2

Fig. 5 – Side Scrub Brush Group

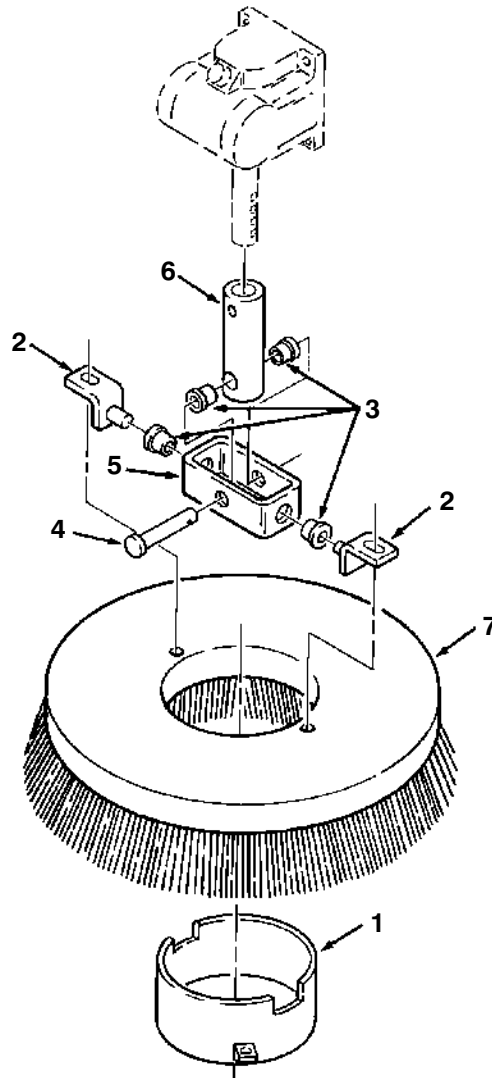

03103

NOTE: Scrubber Attachment Kit, TENNANT Part Number 01027, Includes Fig. 1, 2, 3, 4, 5, and 6.

Key	TENNANT Part No.	Machine Serial Number	Description	Qty.
1	29592	(000000–)	Ring	1
2	31039	(000000–)	Pivot	2
3	29585	(000000–)	Bushing, Flange	4
4	17461	(000000–)	Pin, Clevis	1
5	31037	(000000–)	Tube, Swivel Box	1
6	29586	(000000–)	Tube, Hub	1
7	29406	(000000–)	Side Brush, Scrubbing, Polypropylene	1

Fig. 6 – Vacuum Fan Deflector and Hose Group

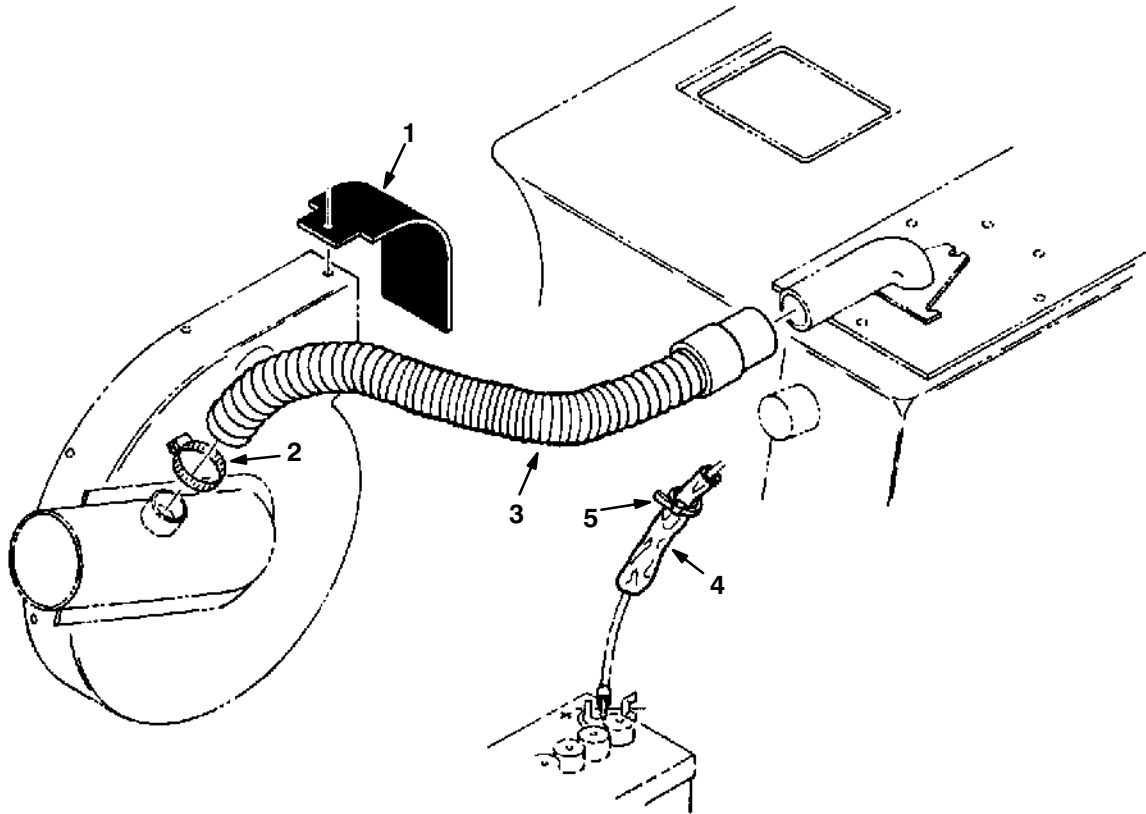

03118

NOTE: Scrubber Attachment Kit, TENNANT Part Number 01027, Includes Fig. 1, 2, 3, 4, 5, and 6.

Key	TENNANT Part No.	Machine Serial Number	Description	Qty.
1	01261	(000000–)	Deflector	1
2	11531	(000000–)	Clamp, Worm Drive	1
3	01637	(000000–)	Hose and Cuff Assembly	1
4	57452	(000000–)	Sleeve	1
5	49266	(000000–)	Tie, Cable	1

Fig. 7 – Vacuum Fan Shutoff Group

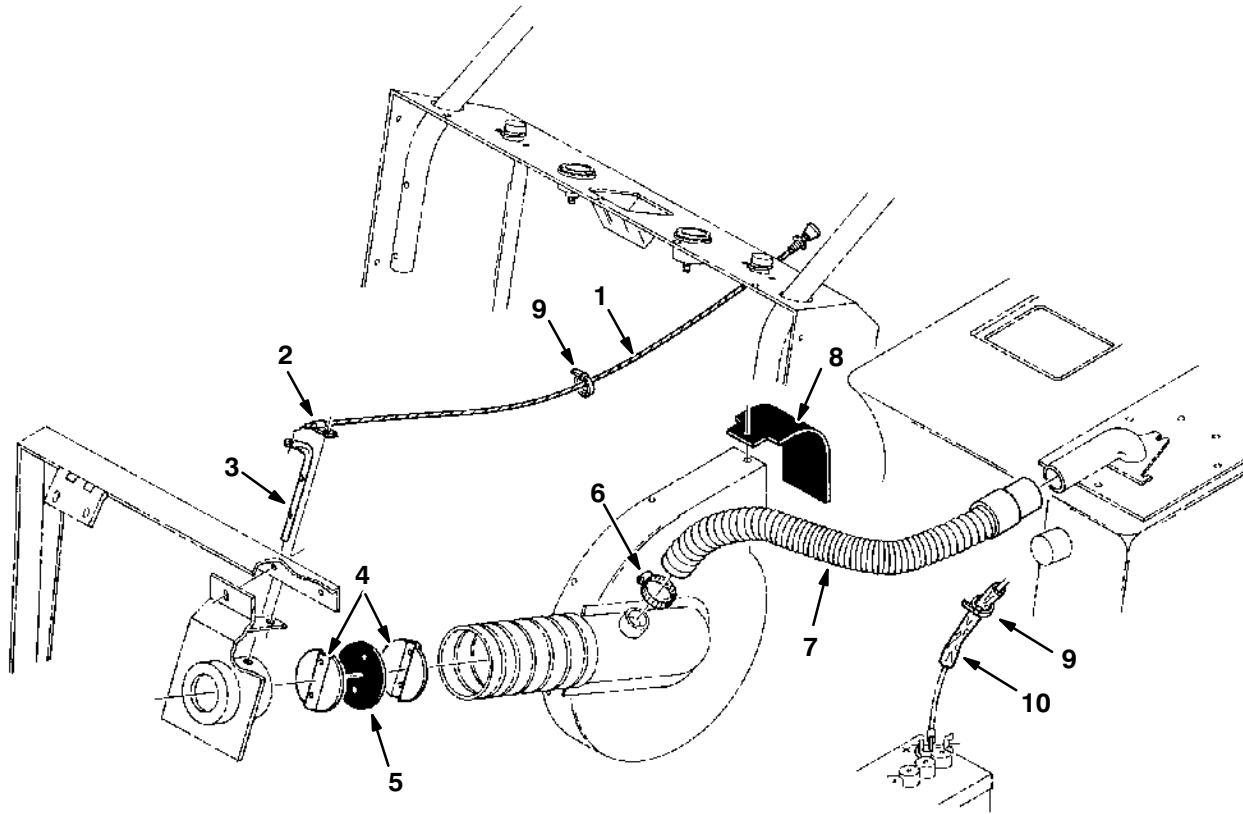

03520

NOTE: Water Pickup Kit, TENNANT Part Number 08070, Includes Fig. 3, 4, 7, and 8.

Key	TENNANT Part No.	Machine Serial Number	Description	Qty.
1	08078	(000000–)	Cable, Control	1
2	26414	(000000–)	Clamp, Cable	1
3	41294	(000000–)	Lever, Damper	1
4	46140	(000000–)	Plate, Damper	2
5	46139	(000000–)	Seal	1
6	11531	(000000–)	Clamp, Worm Drive	1
7	01637	(000000–)	Hose and Cuff Assembly, Vacuum	1
8	01261	(000000–)	Deflector	1
9	49266	(000000–)	Tie, Cable	2
10	57452	(000000–)	Sleeve, Hydraulic	1

Fig. 8 – Recovery Tank Group, Water Pickup

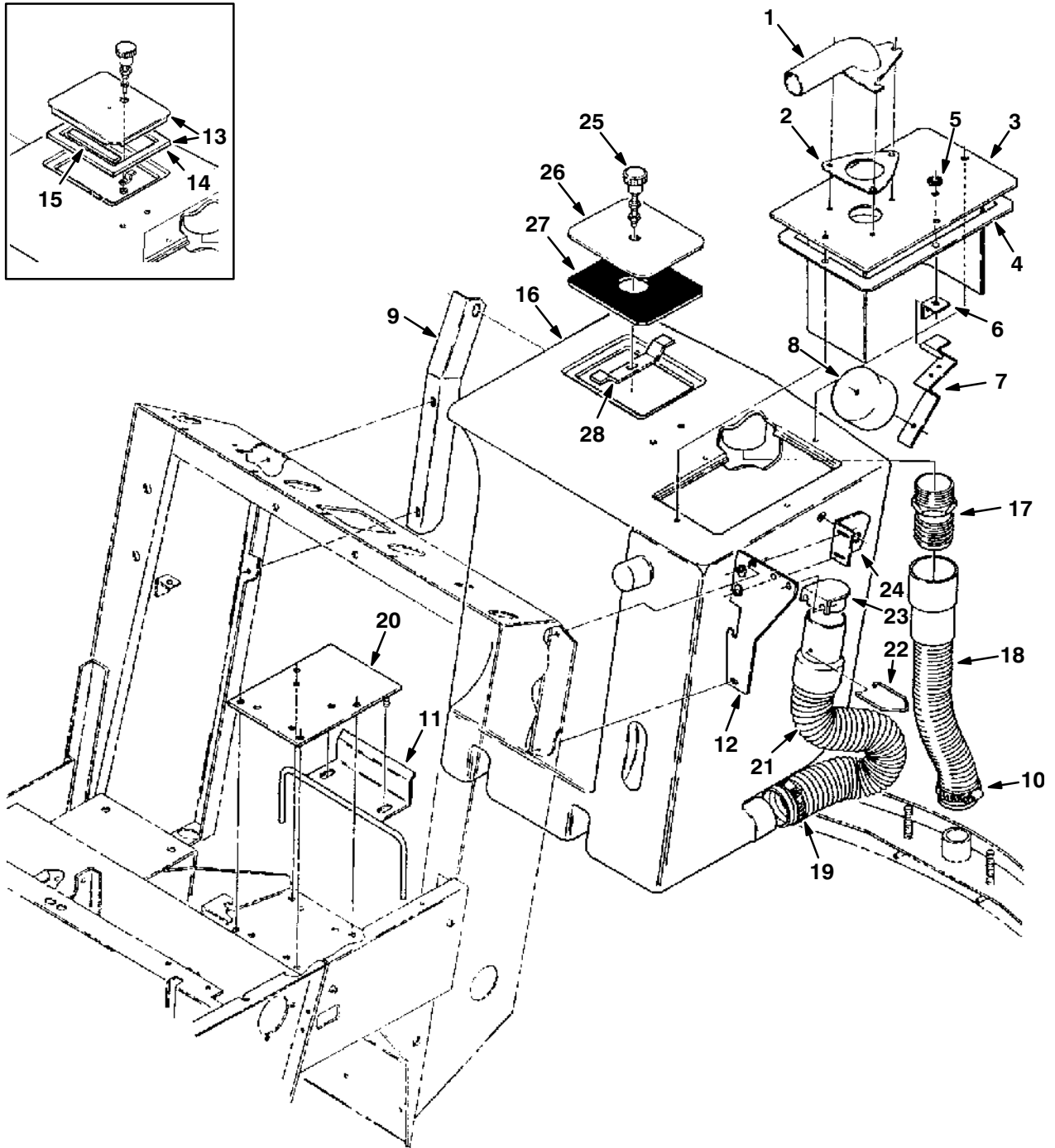
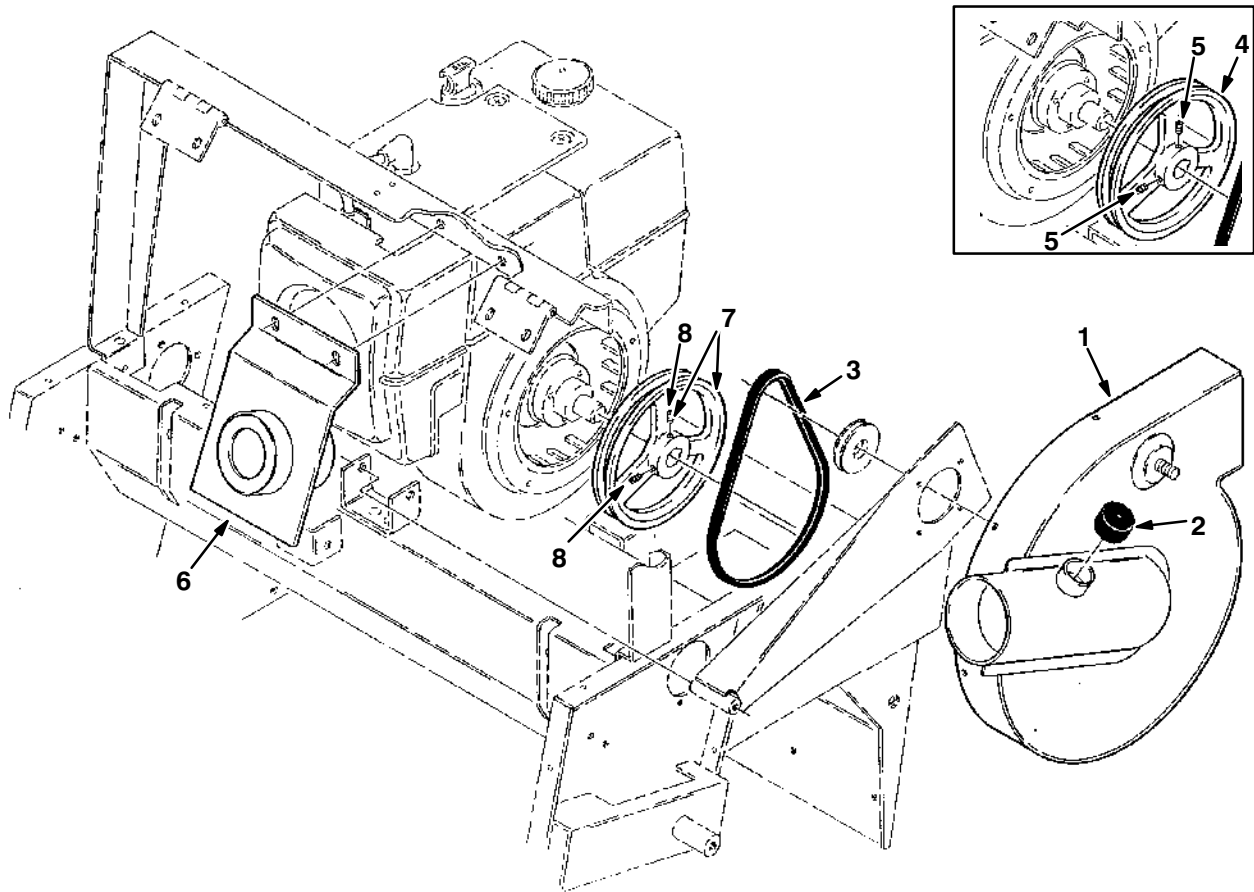

Fig. 8 – Recovery Tank Group, Water Pickup

NOTE: Water Pickup Kit, TENNANT Part Number 08070, Includes Fig. 3, 4, 7, and 8.

Key	TENNANT Part No.	Machine Serial Number	Description	Qty.
1	01520	(000000–)	Tube	1
2	29664	(000000–)	Gasket	1
3	01525	(000000–)	Plate, Float	1
4	01640	(000000–)	Gasket, Float Plate	1
5	76426	(000000–002670)	Washer, Sealing	2
5	76426	(002671–)	Washer, Sealing	1
6	63310	(000000–002670)	Bracket, L	2
6	63310	(002671–)	Bracket, L	1
7	45938–1	(000000–)	Bracket, Float Mounting	1
8	45937	(000000–)	Float, Vacuum Fan	1
9	01492	(000000–)	Bracket, Tie Down, R.H.	1
10	11531	(000000–)	Clamp, Worm Drive	1
11	01534	(000000–)	Retainer	1
12	01499	(000000–)	Bracket, Pickup Handle	1
▽ 13	06762	(000000–002216)	Cover Assembly, Tank (Replaced by 10218)	1
▲ 14	28950–2	(000000–002216)	Seal, Foam Rubber	1
▲ 15	49351–3	(000000–002216)	Seal, Foam Rubber	1
16	01286	(000000–)	Tank, Recovery	1
17	01639	(000000–)	Fitting, Barbed, Straight	1
18	01536	(000000–)	Hose, Squeegee	1
19	22297	(000000–)	Clamp, Worm Drive	1
20	01413	(000000–)	Support, Tank	1
21	30246	(000000–)	Hose, Drain	1
22	20267	(000000–)	Clip, Retainer	1
23	20215	(000000–)	Plug	1
24	01494	(000000–)	Bracket, Tie Down, L.H.	1
▽ 10218		(002217–)	Cover and Seal Assembly, Recovery Tank	1
▲ 25	87337	(000000–)	Latch, Door	1
▲ 26	08091	(002217–)	Cover, Recovery Tank	1
▲ 27	08092	(002217–)	Gasket, Cover	1
▲ 28	08093	(002217–)	Pawl, Latch	1

Fig. 9 – Prep For Scrub and Wand Kit



03113

Key	TENNANT Part No.	Machine Serial Number	Description	Qty.
▽	01452	(000000–)	Prep For Scrub and Wand Kit	1
▲ 1	10357	(000000–)	Housing, Vacuum Fan	1
▲ 2	01330	(000000–)	Plug, Cap	1
▲ 3	01595	(000000–)	V-Belt	1
▲ 4	06666	(000000–002634)	Sheave Replacement Kit	1
▲ 5	39330	(000000–002634)	Screw, Set	2
▲ 6	41293	(000000–)	Adaptor, Filter to Fan	1
▲▽ 7	06665	(002635–)	Sheave	1
▲▲ 8	39338	(002635–)	Screw, Set	2

Fig. 10 – Vacuum Wand Group

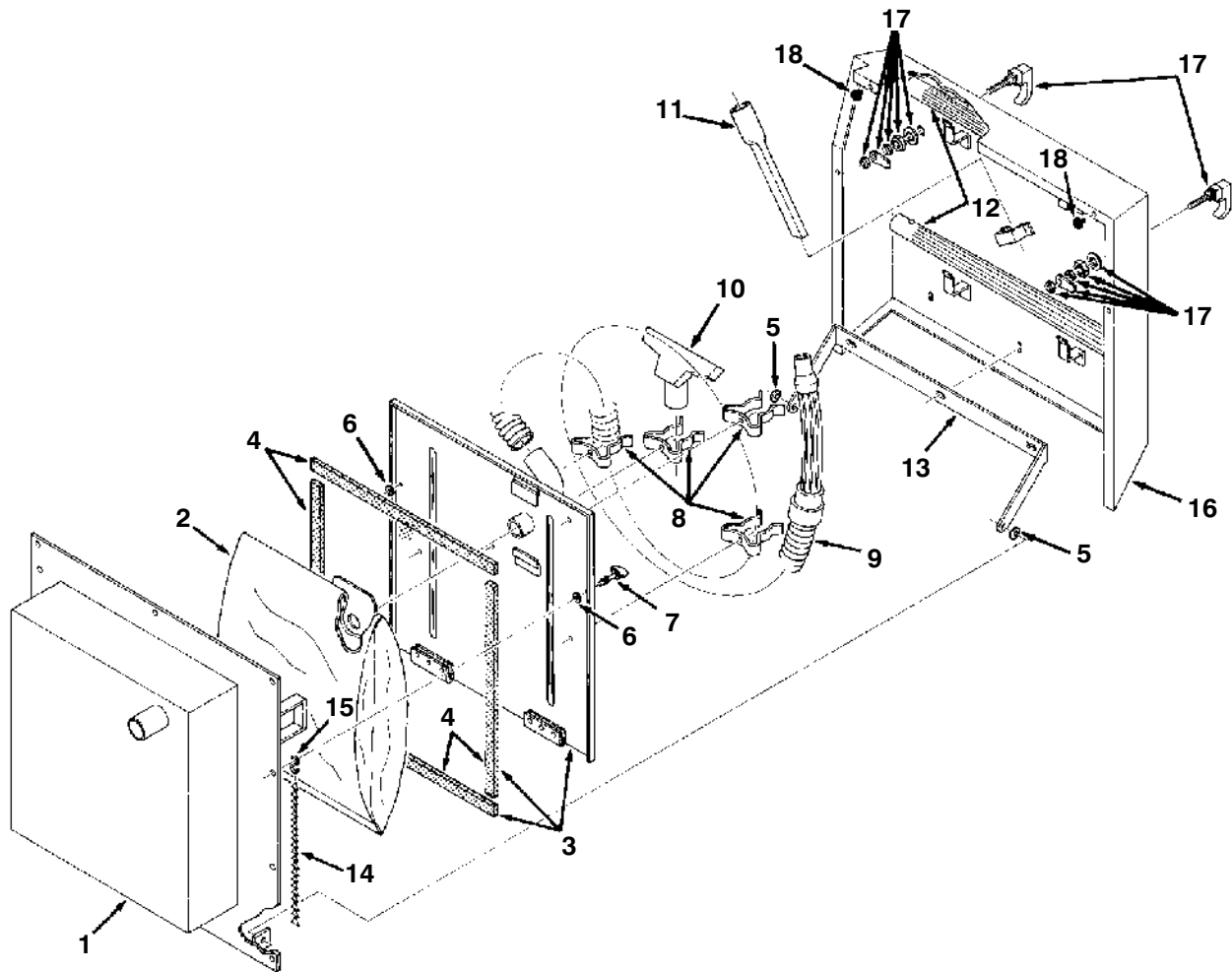

03115

NOTE: Vacuum Wand Kit, TENNANT Part Number 01030, Includes Fig. 10 and 11.

Key	TENNANT Part No.	Machine Serial Number	Description	Qty.
1	01398	(000000–005999)	Frame, Mounting and Vacuum Box	1
2	06482	(000000–005999)	Bags, Vacuum Wand (Set of 10)	1
3	06741	(000000–005999)	Door Assembly, Vacuum Box	1
4	01392	(000000–005999)	Seal, Foam Rubber	4
5	43611	(000000–005999)	Washer, Nylon	2
6	26015	(000000–005999)	Fastener	2
7	25656	(000000–005999)	Fastener, Winghead	2
8	67004	(000000–005999)	Clip, Finger Grip	4
9	01617	(000000–005999)	Hose, Vacuum	1
10	01613	(000000–005999)	Nozzle, Master	1
11	01615	(000000–005999)	Tool, Crevice	1
12	01618	(000000–005999)	Wand	2
13	04057	(000000–005999)	Hinge	1
14	06121	(000000–005999)	Chain	2
15	43363	(000000–005999)	Hook, S	2
16	04060	(000000–005999)	Cover, Vacuum Wand	1
17	49302	(000000–005999)	Latch, Adjustable	2
18	51787	(000000–005999)	Bumper, Rubber	2

Fig. 11 – Vacuum Wand Control Group

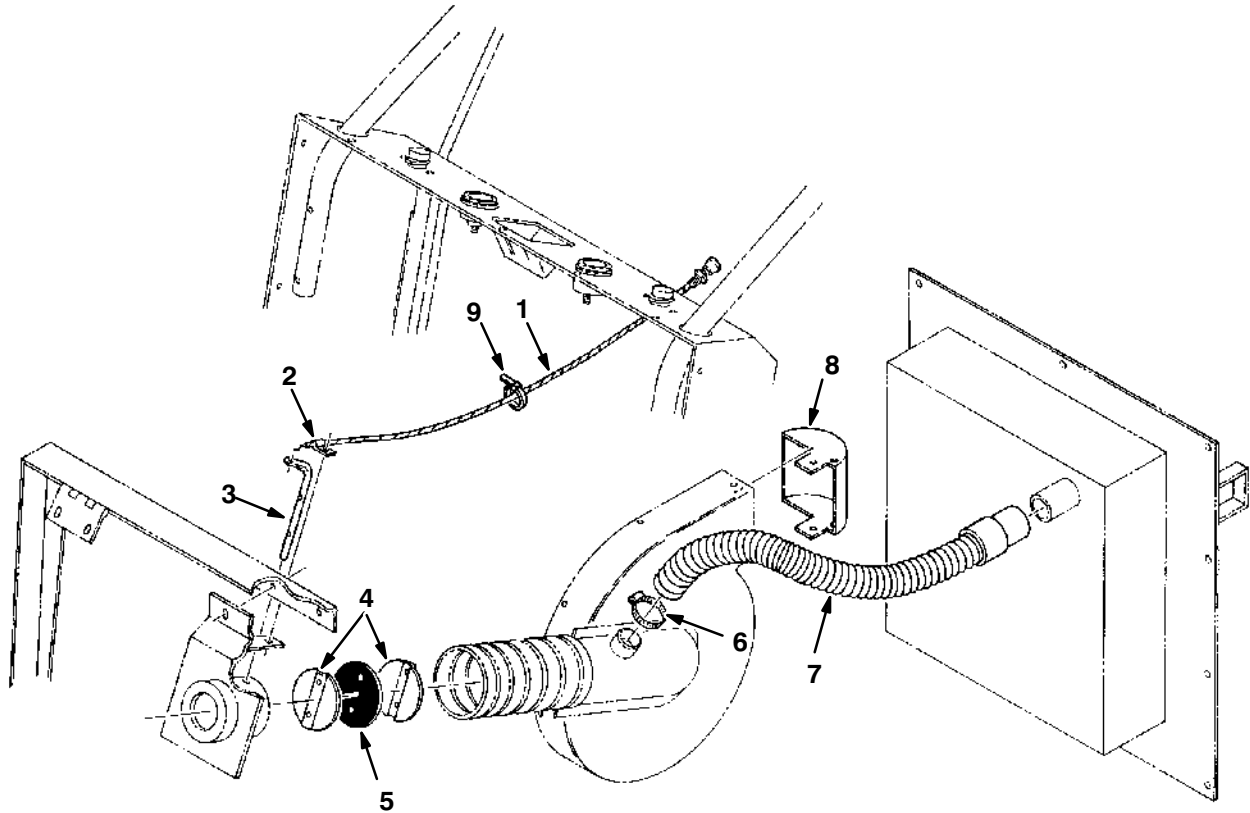

03116

NOTE: Vacuum Wand Kit, TENNANT Part Number 01030, Includes Fig. 10 and 11.

Key	TENNANT Part No.	Machine Serial Number	Description	Qty.
1	08078	(000000–005999)	Cable, Damper Control	1
2	26414	(000000–005999)	Clamp, Cable	1
3	01393	(000000–005999)	Lever, Damper	1
4	46140	(000000–005999)	Plate, Damper	2
5	46139	(000000–005999)	Seal	1
6	11531	(000000–005999)	Clamp, Worm Drive	1
7	01637	(000000–005999)	Hose and Cuff Assembly	1
8	01225	(000000–005999)	Deflector	1
9	49266	(000000–005999)	Tie, Cable	1

Fig. 12 – Vacuum Wand Group

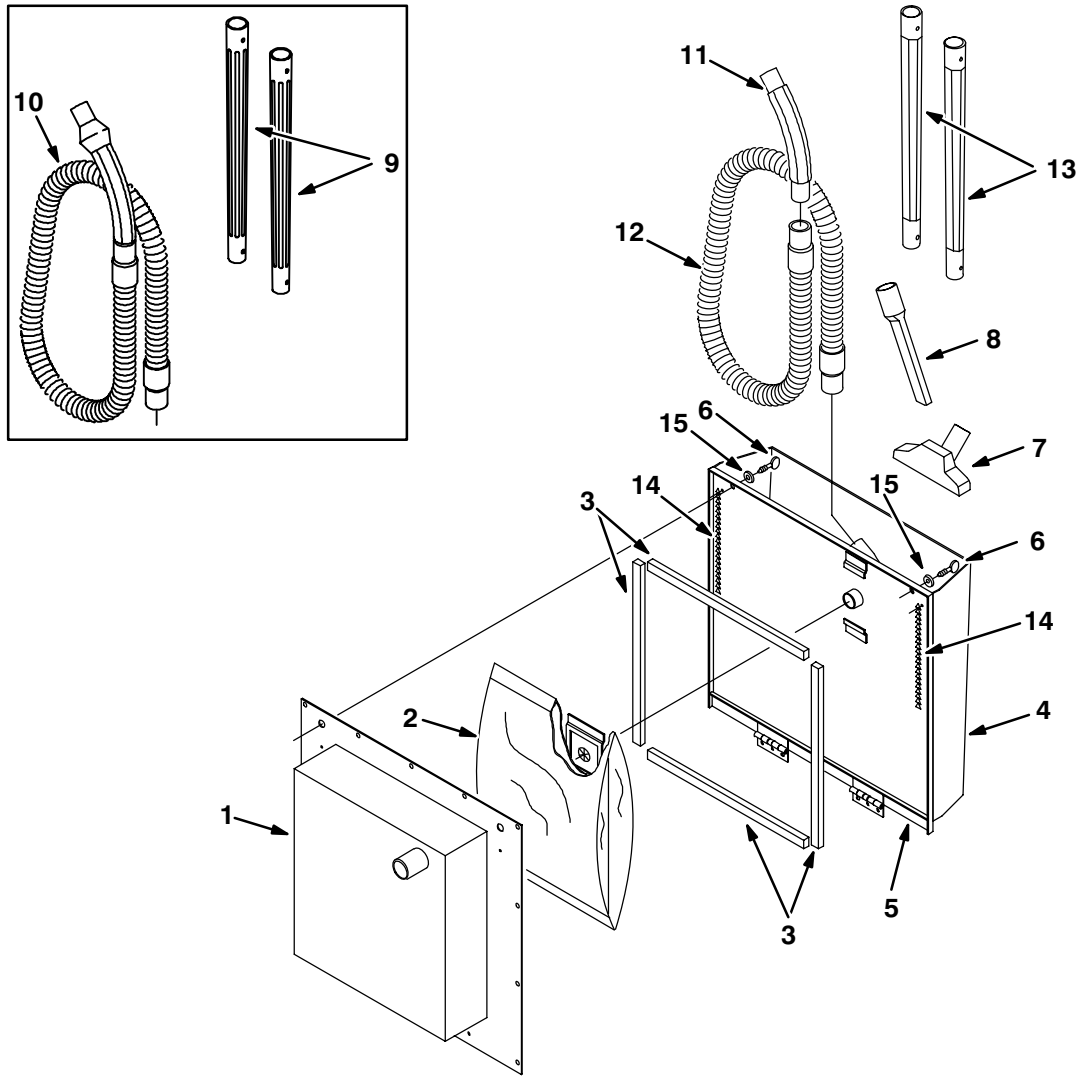

06345

NOTE: Vacuum Wand Kit, TENNANT Part Number 41272, Includes Fig. 12 and 13.

Key	TENNANT Part No.	Machine Serial Number	Description	Qty.	
1	61100	(006000–)	Box Wldt, Vac	1	
2	01654	(006000–)	Bags, Vacuum (Disposable)	3	
3	53461–2	(006000–)	Seal, Foam Rubber	4	
▽	65360	(006000–)	Cover Assembly, Vacuum Wand	1	
▲	4	61078	(006000–)	Cover, Vacuum Wand	1
▲	5	65359	(006000–)	Plate, Vacuum Box	1
6	25656	(006000–)	Screw, Thumb	2	
7	01613	(006000–)	Nozzle, Master	1	
8	01615	(006000–)	Tool, Crevis	1	
9	01618	(006000–007063)	Wand, Extension	2	
10	61668	(006000–007063)	Replacment Kit, Hose, Wand F/01617	1	
11	05584	(007064–)	Hose End, Curved	1	
12	05594	(007064–)	Hose Assy, Vacuum Wand	1	
13	05579	(007064–)	Wand, Vacuum	2	
14	65357	(006000–)	Chain, Sash	2	
15	32490	(006000–)	Washer, flt	2	

Fig. 13 – Vacuum Wand Control Group

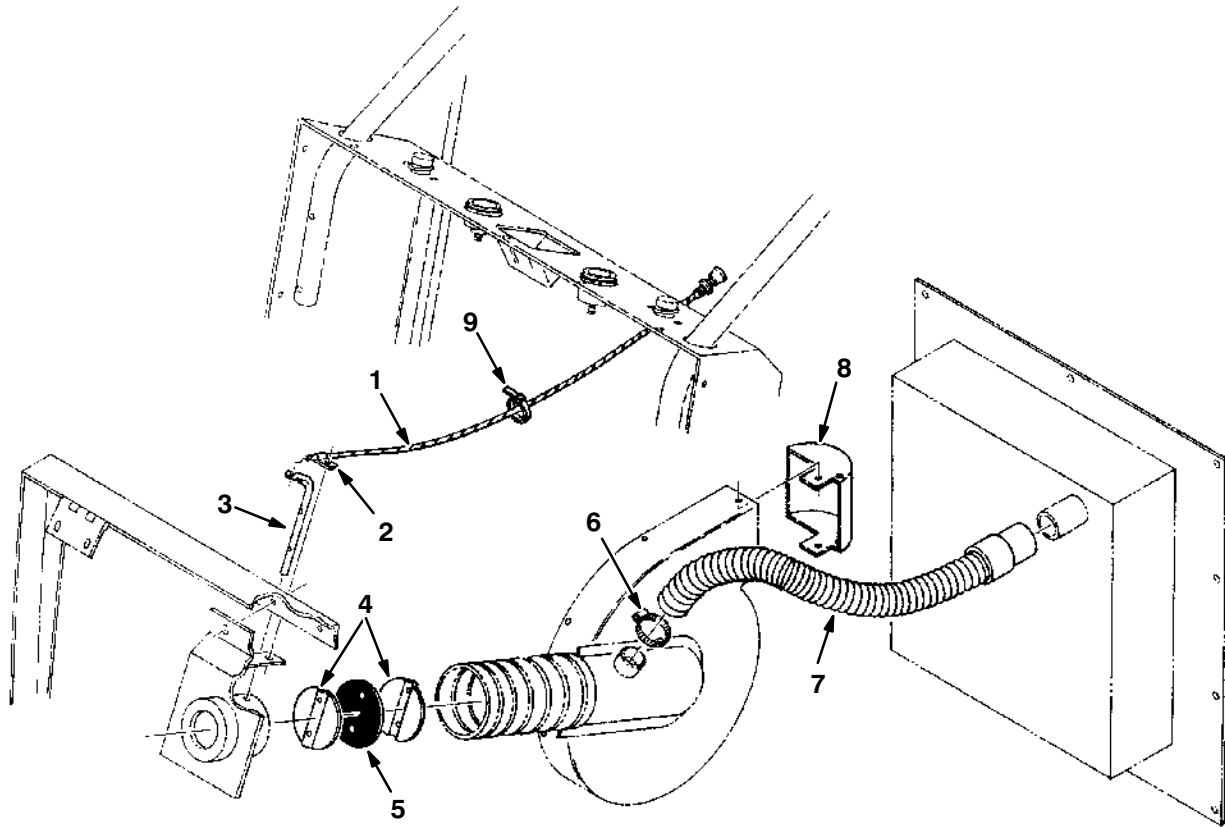

06443

NOTE: Vacuum Wand Kit, TENNANT Part Number 41272, Includes Fig. 12 and 13.

Key	TENNANT Part No.	Machine Serial Number	Description	Qty.
1	08078	(006000–)	Cable, Damper Control	1
2	26414	(006000–)	Clamp, Cable	1
3	41294	(006000–)	Lever, Damper	1
4	46140	(006000–)	Plate, Damper	2
5	46139	(006000–)	Seal	1
6	11531	(006000–)	Clamp, Worm Drive	1
7	01637	(006000–)	Hose and Cuff Assembly	1
8	01225	(006000–)	Deflector	1
9	49266	(006000–)	Tie, Cable	1

Fig. 14 – Filter Bypass Kit

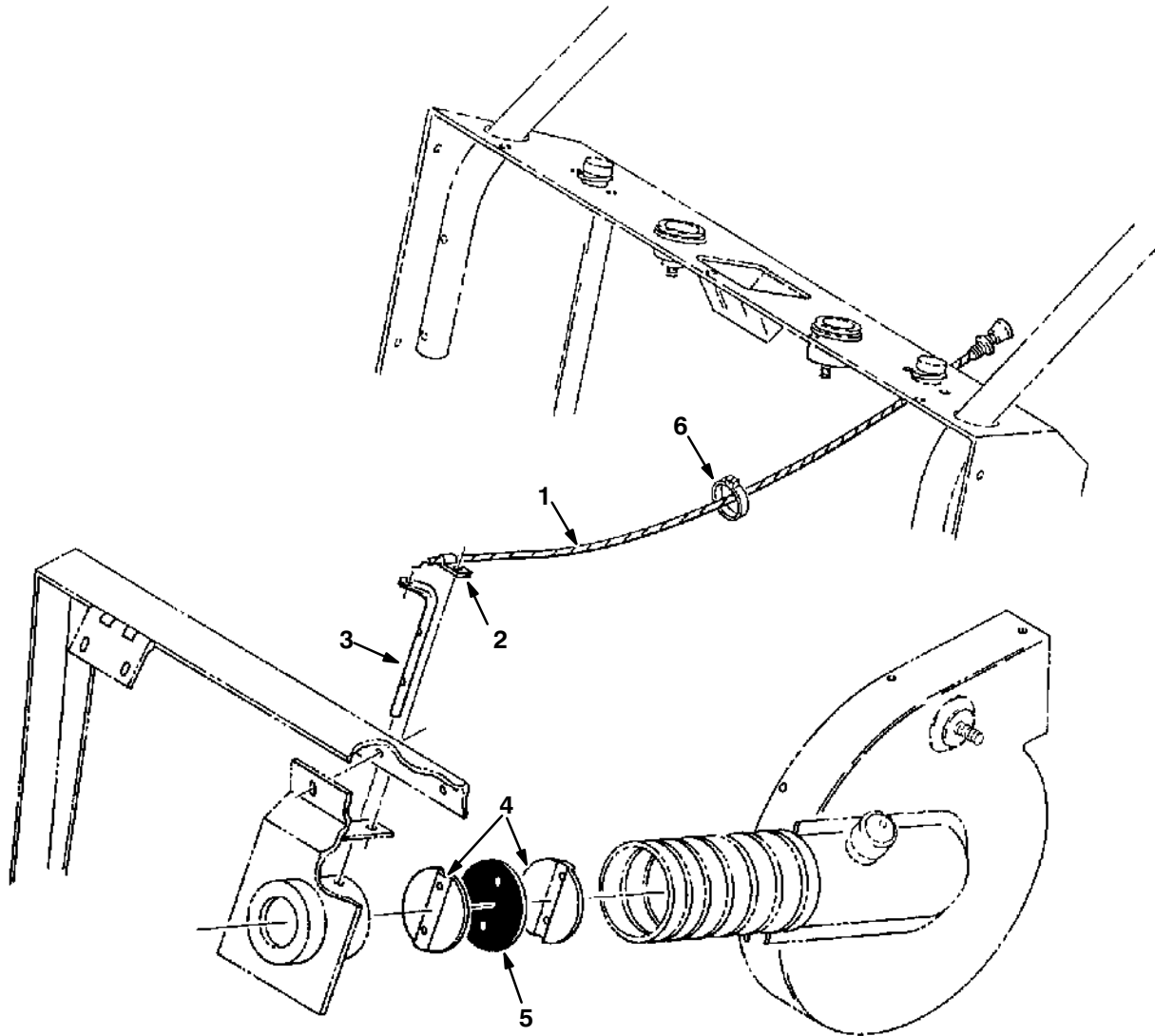

03518

Key	TENNANT Part No.	Machine Serial Number	Description	Qty.
▽	08076	(006000–)	Filter Bypass Kit	1
▲ 1	08078	(006000–)	Cable, Control	1
▲ 2	26414	(006000–)	Clamp, Cable	1
▲ 3	41294	(006000–)	Lever, Damper	1
▲ 4	46140	(006000–)	Plate, Damper	2
▲ 5	46139	(006000–)	Seal	1
▲ 6	49266	(006000–)	Tie, Cable	1
▲	46236	(006000–)	Clamp, Cable	1

Fig. 15 – Fine Particle Filter Kit

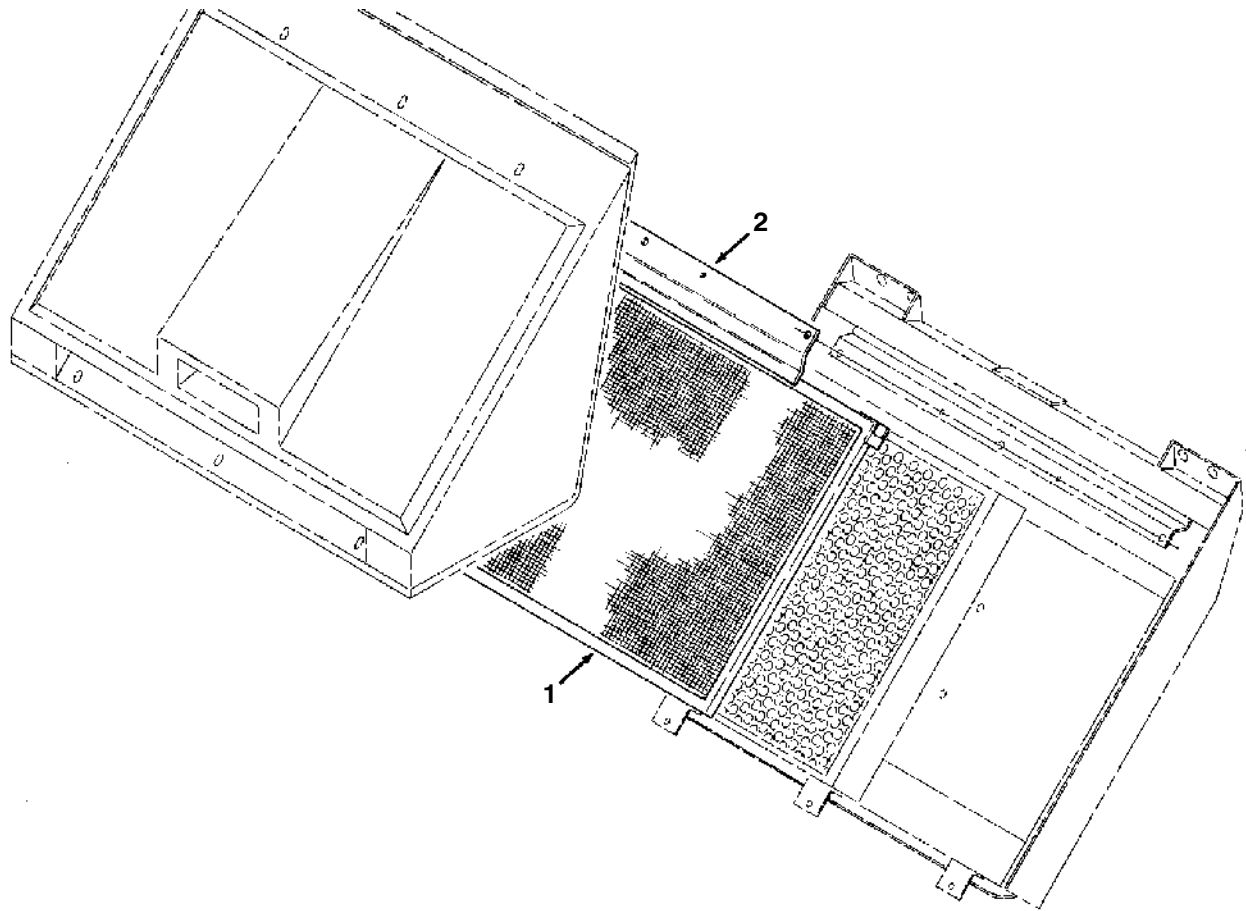

03124

Key	TENNANT Part No.	Machine Serial Number	Description	Qty.
▽	06733	(000000–)	Filter Kit, Fine Particle	1
▲ 1	32557	(000000–)	Filter Assembly, Fine Particle	1
▲ 2	01154	(000000–)	Bracket, Hold Down	1

Fig. 16 – Lift and Tie-Down Kit

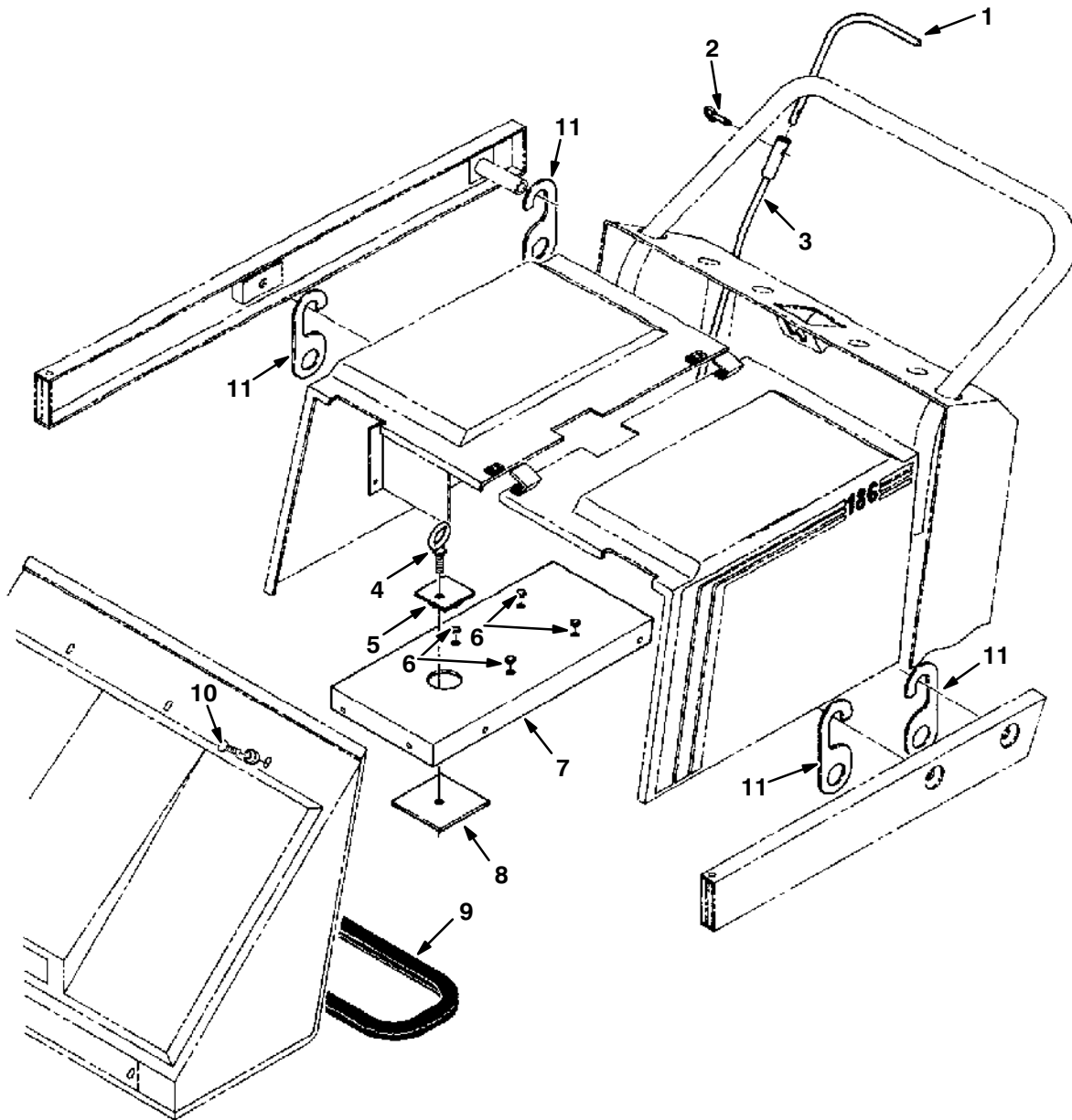

03117

Key	TENNANT Part No.	Machine Serial Number	Description	Qty.
▽	06735	(000000-005999)	Lift and Tie-Down Kit	1
▲	1	01486 (000000-005999)	Handle, Directional	1
▲	2	01224 (000000-005999)	Pin, Hitch	1
▲	3	01488 (000000-002506)	Rod, Directional	1
▲	3	08039 (002507-005999)	Rod, Directional	1
▲	4	42173-1 (000000-005999)	Eyebolt	1
▲	5	01638 (000000-005999)	Collar	1
▲	6	33806 (000000-005999)	Plugbutton	4
▲	7	01189 (000000-005999)	Brace, Center	1
▲	8	01482 (000000-005999)	Plate, Lift Support	1
▲	9	12082 (000000-005999)	Cover, Protective Filter	1
▲	10	39778 (000000-005999)	Screw, Thumb	6
▲	11	08077 (000000-005999)	Tie-Down	4

Fig. 17 – Lift and Tie-Down Kit

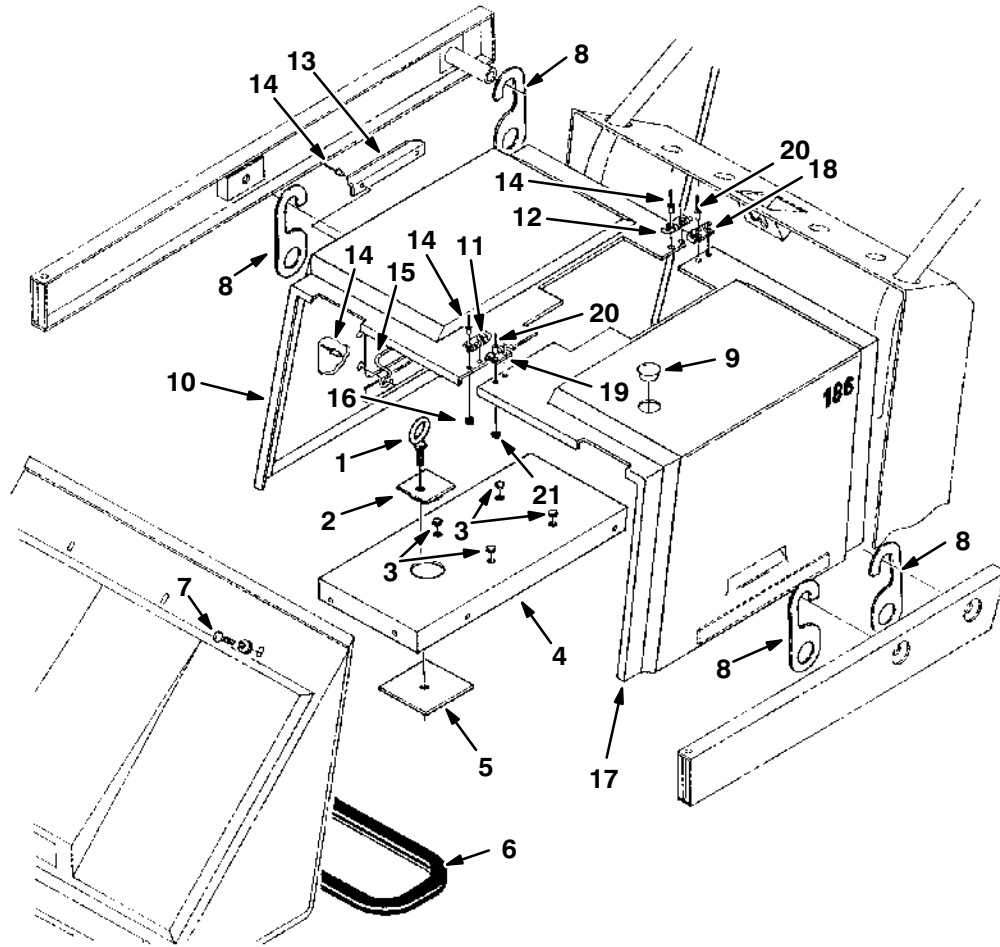

06441

Key	TENNANT Part No.	Machine Serial Number	Description	Qty.
▽	60040	(006000–)	Lift and Tie-Down Kit	1
▲ 1	78556	(006000–)	Eyebolt	1
▲ 2	01638	(006000–)	Collar	1
▲ 3	33806	(006000–)	Plugbutton	4
▲ 4	09487	(006000–)	Brace, Center	1
▲ 5	01482	(006000–)	Plate, Lift Support	1
▲ 6	12082	(006000–)	Cover, Protective Filter	1
▲ 7	78557	(006000–)	Screw, Thumb	6
▲ 8	08077	(006000–)	Tie-Down	4
▲ 9	06476	(006000–)	Plugbutton	1
▽ 10	61064	(006000–)	Cover Assembly, R.H.	1
▲ 11	50832	(006000–)	Hinge, Pull Pin L.H.	1
▲ 12	50835	(006000–)	Hinge, Pull Pin R.H.	1
▲ 13	50894	(006000–)	Handle, Cover	1
▲ 14	01335	(006000–)	Rivet, Soft	10
▲ 15	12964	(006000–)	Guard, Muffler	2
▲ 16	64757	(006000–)	Bumper, Rubber	2
▽ 17	61065	(006000–)	Cover Assembly, L.H.	1
▲ 18	50832	(006000–)	Hinge, Pull Pin L.H.	1
▲ 19	50835	(006000–)	Hinge, Pull Pin R.H.	1
▲ 20	01335	(006000–)	Rivet, Soft	4
▲ 21	64757	(006000–)	Bumper, Rubber	2

Fig. 18 – Parking Brake Kit

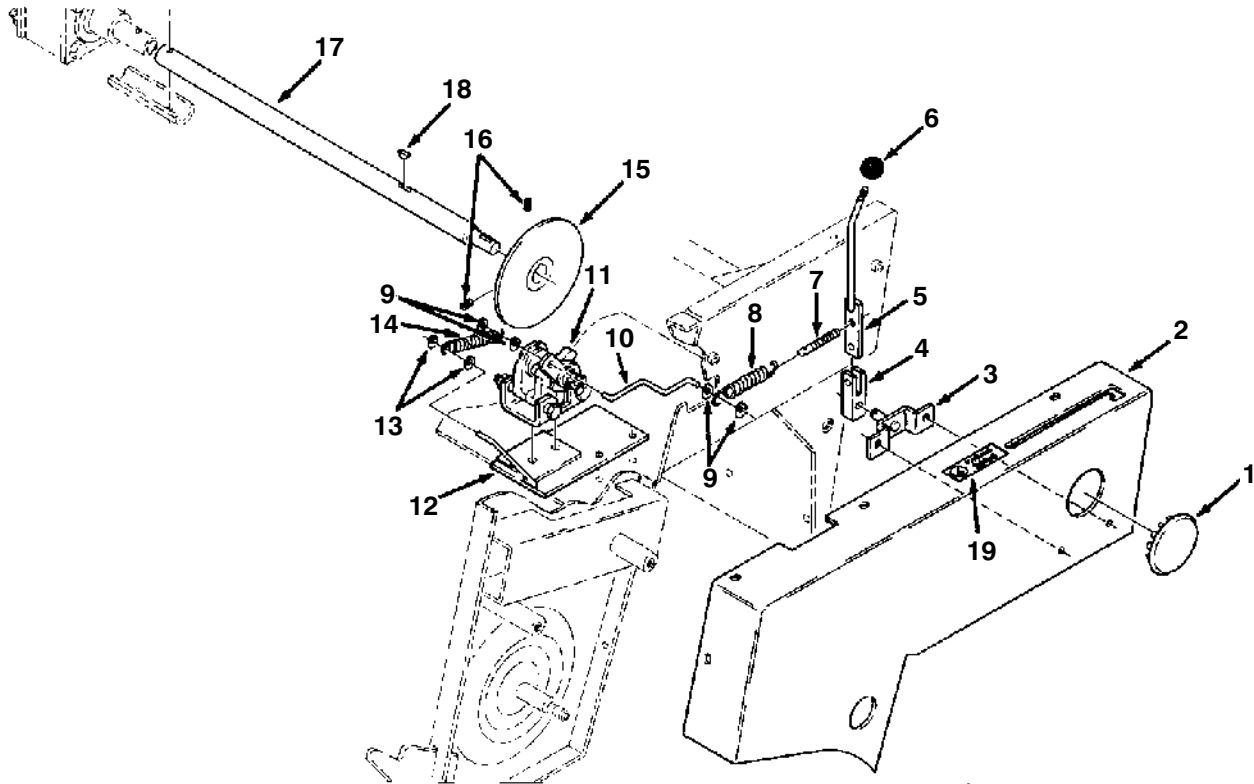

03052

Key	TENNANT Part No.	Machine Serial Number	Description	Qty.
▽	01444	(000000-002315)	Brake Kit, Parking (Replaced by 10368)	1
▲ 1	82747	(000000-002315)	Plugbutton	1
▲ 2	01469	(000000-002315)	Cover, L.H.	1
▲ 3	01473	(000000-002315)	Bracket, Parking Brake	1
▲ 4	01476	(000000-002315)	Pivot, Parking Brake	1
▲ 5	01479	(000000-002315)	Handle, Parking Brake	1
▲ 6	01506	(000000-002315)	Knob	1
▲ 7	01554	(000000-002315)	Screw, Adjustment	1
▲ 8	28281	(000000-002315)	Spring, Tension	1
▲ 9	39021	(000000-002315)	Ring, Retaining	4
▲ 10	01471	(000000-002315)	Link, Brake	1
▲ 11	01470	(000000-002315)	Brake	1
▲ 12	01438	(000000-002315)	Plate, Adaptor	1
▲ 13	23524-3	(000000-002315)	Ring, Retaining	2
▲ 14	01053	(000000-002315)	Spring, Tension	1
▲ 15	35927	(000000-002315)	Disc, Brake	1
▲ 16	57496	(000000-002315)	Screw, Nylon Set	2
▲ 17	01439	(000000-002315)	Countershaft	1
▲ 18	00500-10	(000000-002315)	Key, Woodruff	1
▲ 19	63785	(000000-002315)	Decal, Parking Brake	1

Fig. 19 – Parking Brake Kit

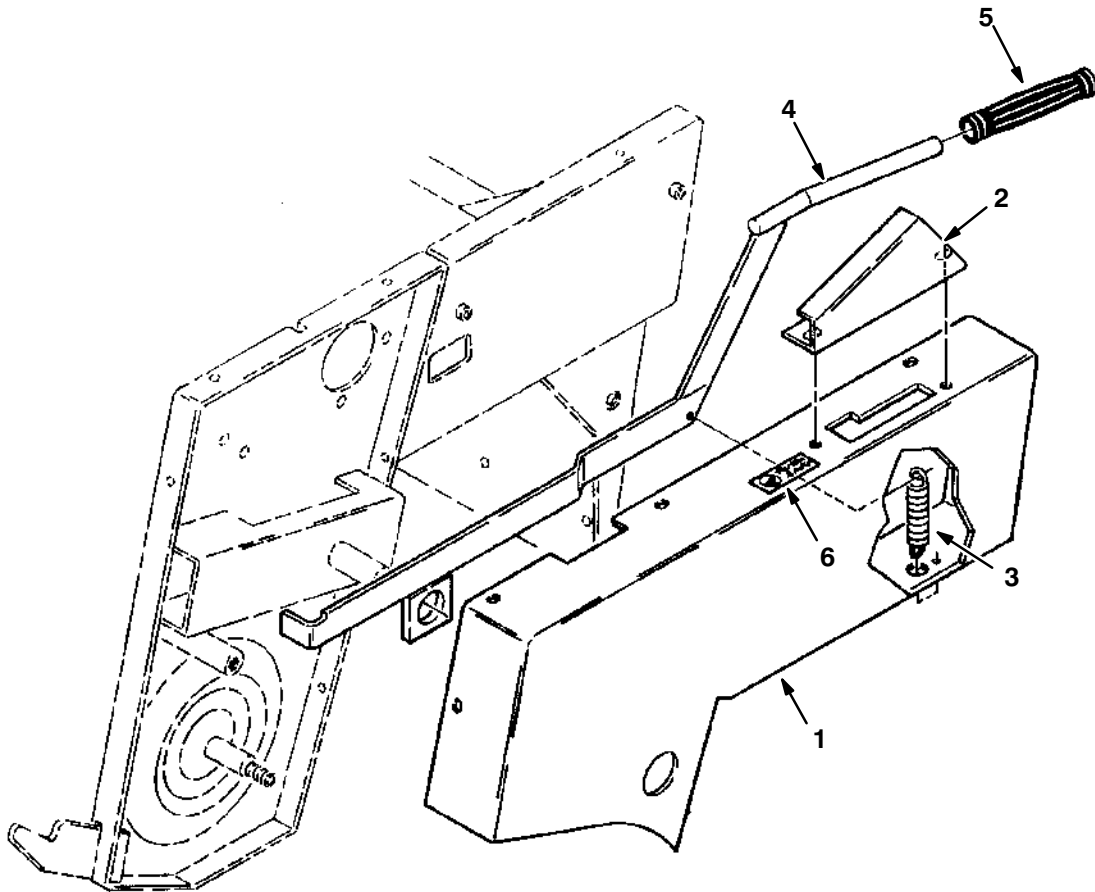

04315

Key	TENNANT Part No.	Machine Serial Number	Description	Qty.
▽	10368	(002316-005999)	Brake Kit, Parking	1
▲ 1	10372	(002316-005999)	Cover, Left Side	1
▲ 2	10379	(002316-005999)	Latch, Brake	1
▲ 3	29545	(002316-005999)	Spring, Tension	1
▲ 4	10378	(002316-005999)	Brake, Parking	1
▲ 5	10381	(002316-005999)	Grip, Handle	1
▲ 6	63785	(002316-005999)	Label, Parking Brake	1

Fig. 20 – Dual Caster Group

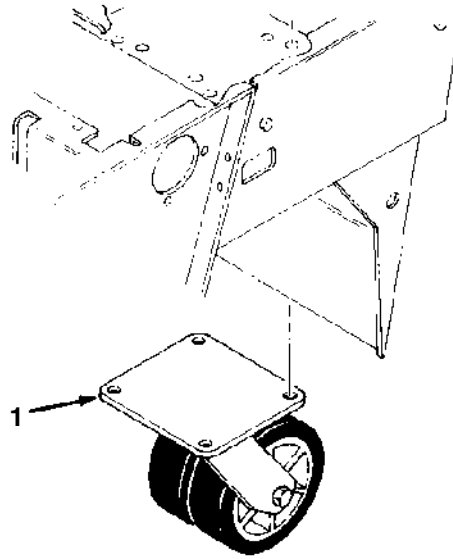

03119

Key	TENNANT Part No.	Machine Serial Number	Description	Qty.
1	01266	(000000–)	Caster, Dual Wheeled	1

Fig. 21 – Fire Extinguisher Kit

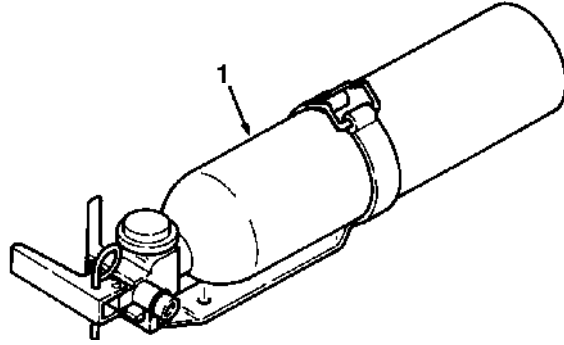

02597

Key	TENNANT Part No.	Machine Serial Number	Description	Qty.
1	46938	(000000–)	Extinguisher Kit, Fire	1
	25312	(000000–)	Extinguisher, Fire	1

Fig. 22 – Fuel Tank Group, LPG

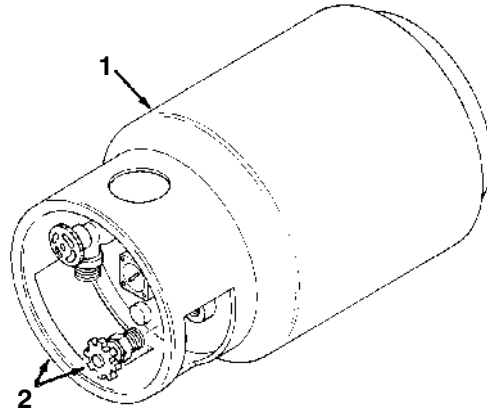

02975

Key	TENNANT Part No.	Machine Serial Number	Description	Qty.
1	10752-3	(000000-) Tank, LPG	1
2	10752-2	(000000-) Tank, LPG, with Filler Valve	1

Fig. 23 – Double Wheel Kit

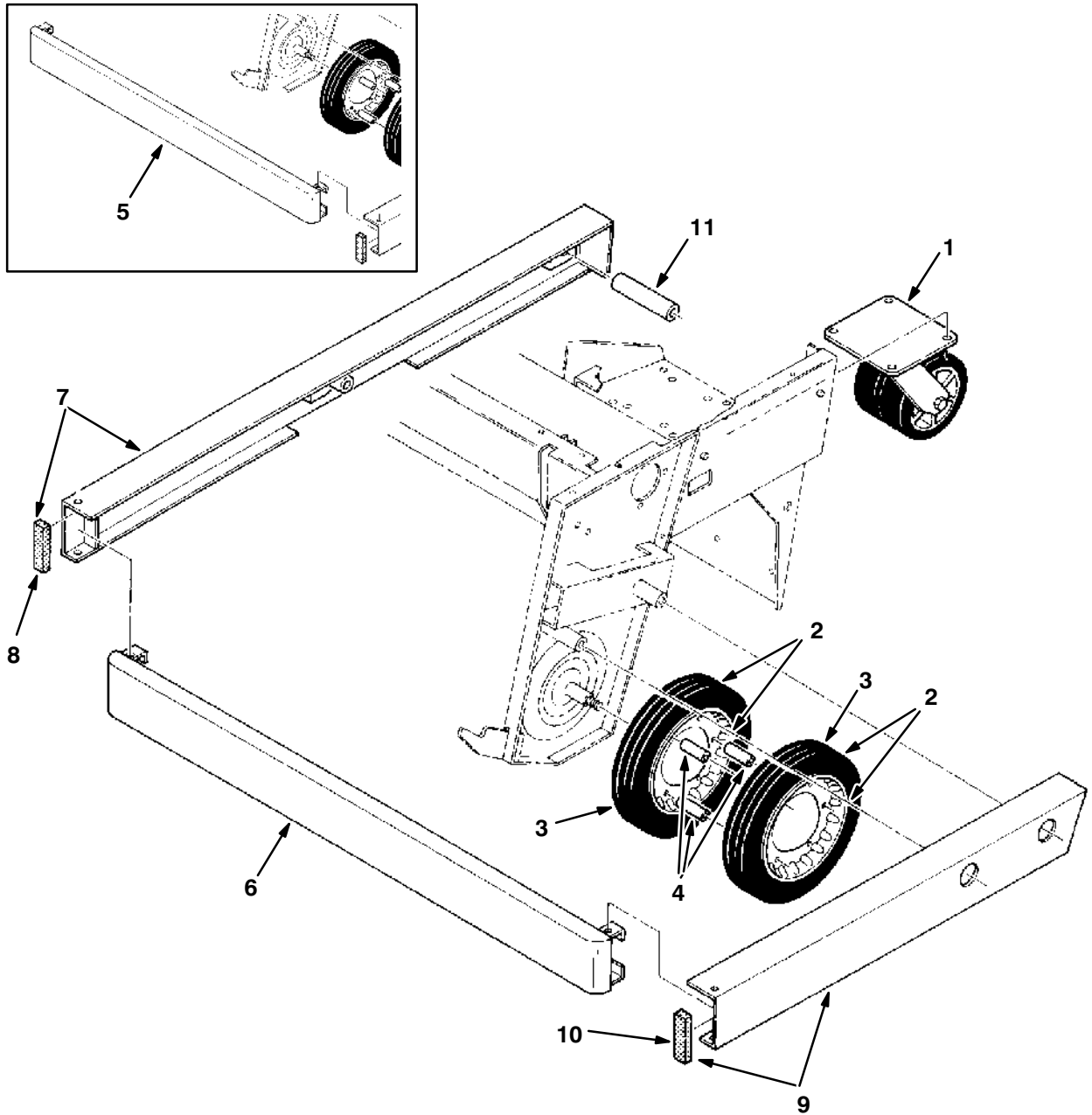

07031

Key	TENNANT Part No.	Machine Serial Number	Description	Qty.
	01040	(000000–)	Double Wheel Kit	1
▲ 1	01266	(000000–)	Caster, Dual Wheeled	1
▲▽ 2	47807	(000000–)	Tire and Wheel Assembly Non Marking	4
▲▲ 3	28311	(000000–)	Tire	1
▲ 4	27055	(000000–)	Sleeve	6
▲ 5	61325	(000000–007142)	Replacement Kit, Front Bumper F/06812	1
▲ 6	61323	(007143–)	Bumper, Front	1
▲▽ 7	06813	(000000–)	Bumper Assembly, R.H.	1
▲▲ 8	28988–1	(000000–)	Seal, Foam Rubber	1
▲▽ 9	06815	(000000–)	Bumper Assembly, L.H.	1
▲▲ 10	28988–1	(000000–)	Seal, Foam Rubber	1
▲ 11	06826	(000000–)	Tube	1

Fig. 24 – Plastic Hopper Kit

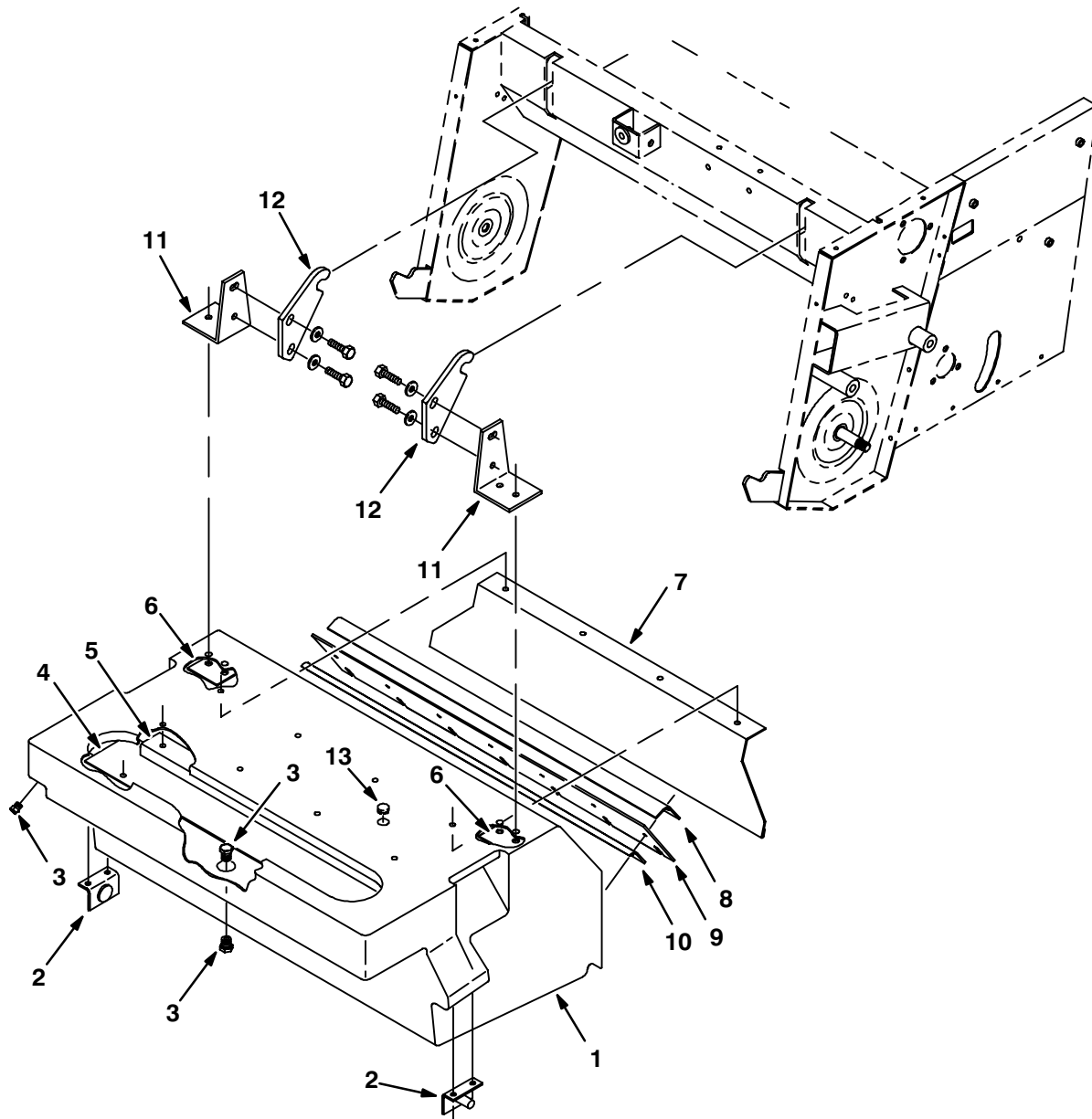

06897

Key	TENNANT Part No.	Machine Serial Number	Description	Qty.
▽	61119	(000000-)	Hopper Kit Plastic 186	1
▲ 1	09363	(000000-)	Hopper, Swppr/Scrbr	1
▲ 2	09481	(000000-)	Bracket, Support Pin	2
▲ 3	50896	(000000-)	Ftg-Plug Npt 02Pm Hx Hd Plstc	3
▲ 4	61086	(000000-)	Strip, Deflector	1
▲ 5	50930	(000000-)	Angle, Stiffener Hopper	1
▲ 6	61087	(000000-)	Plate, Nut	2
▲ 7	09484	(000000-)	Angle, Deflector	1
▲ 8	09483	(000000-)	Angle, Hopper Lip Retainer	1
▲ 9	50775	(000000-)	Rubber, Hopper Lip	1
▲ 10	41306	(000000-)	Angle, Lip Retainer, Lower	1
▲ 11	09482	(000000-)	Bracket, Mounting	2
▲ 12	01132	(000000-)	Plate, Hopper Catch	2
▲ 13	50896	(000000-)	Ftg-Plug Npt 02Pm Hx Hd Plstc	1

Fig. 25 – Documentation Group

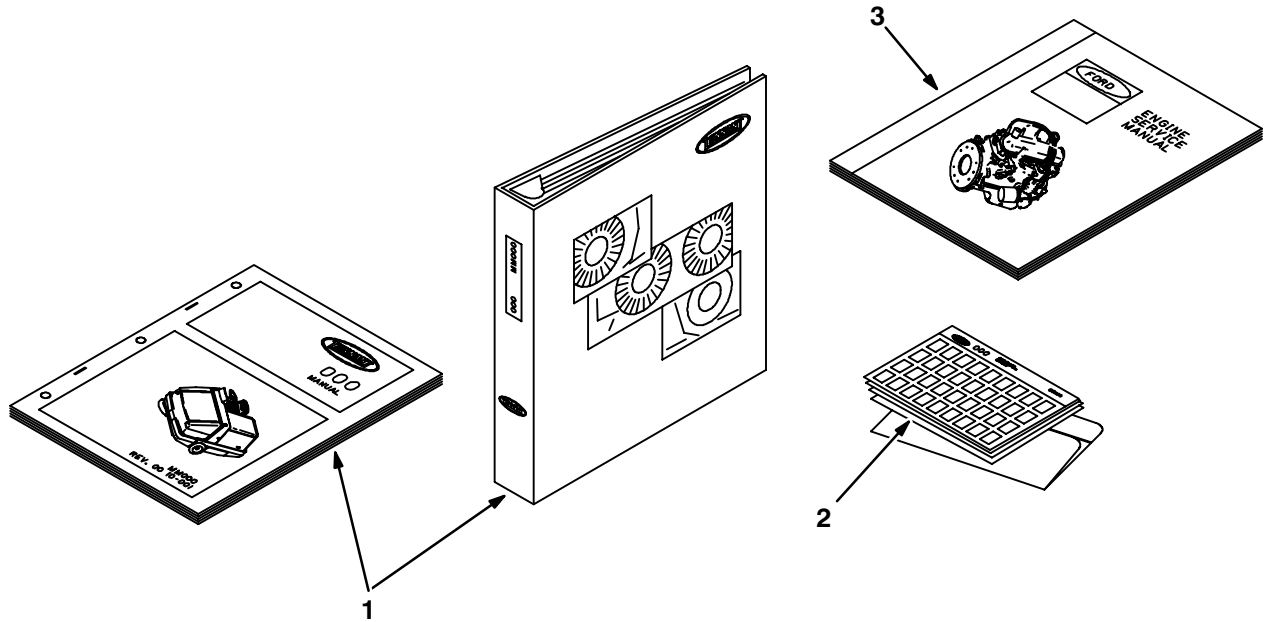

10323/07501

Ref.	TENNANT Part No.	Machine Serial number	Description	Qty.
1	MM159	(000000–)	Manual Pkg 186	1
2	85159	(000000–)	Manual–Fiche Pkg 186G	1
3	38977	(000000–)	Service Manual	1

SECTION 8**CONTENTS**

	Page
Fig. 1 – Crankcase Group	8-2
Fig. 2 – Camshaft and Valves Group	8-4
Fig. 3 – Air Intake Group	8-5
Fig. 4 – Baffles and Shroud Group	8-6
Fig. 5 – Breather and Vent Group	8-7
Fig. 6 – Flywheel Group	8-8
Fig. 7 – Electric Start Group	8-9
Fig. 8 – Governor Group	8-10
Fig. 9 – Ignition Group	8-11
Fig. 10 – Carburetor Group, Gasoline	8-12
Fig. 11 – Carburetor Group, Gasoline	8-13
Fig. 12 – Fuel Pump Group	8-14
Fig. 13 – Fuel Tank Group	8-15
Fig. 14 – Fuel Pump Group, LPG	8-16
Fig. 15 – Carburetor Group, LPG	8-17

Fig. 1 – Crankcase Group

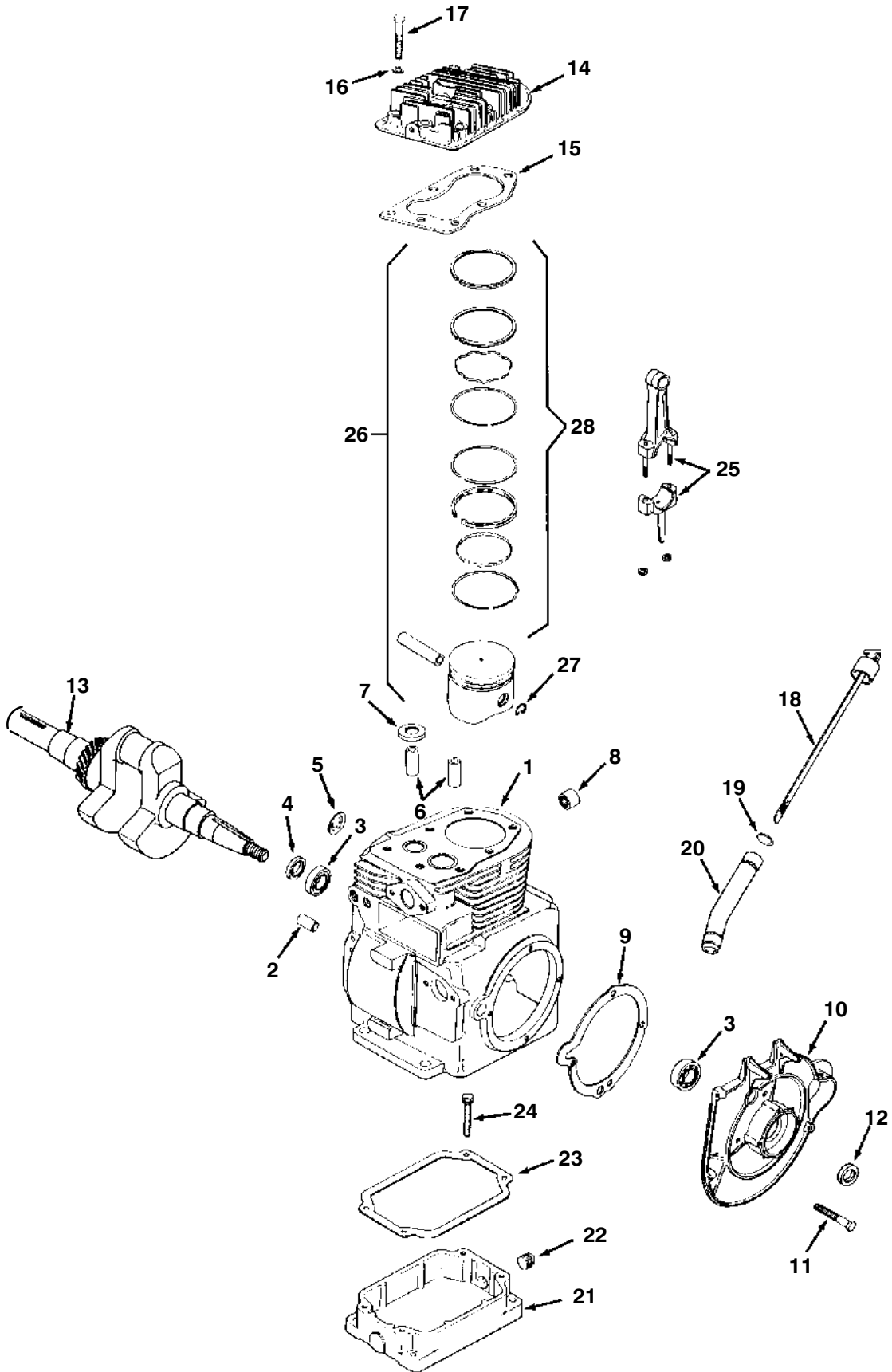
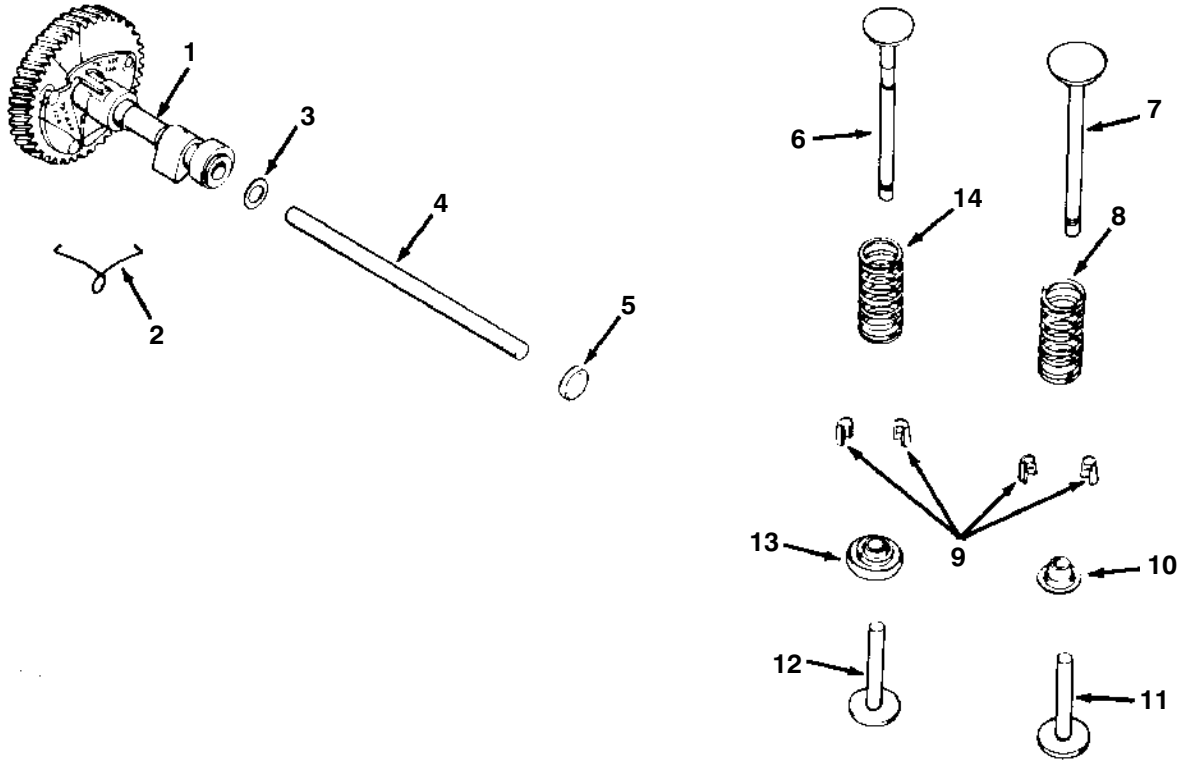

Fig. 1 – Crankcase Group

Key	TENNANT Part No.	Kohler® Part No.	Engine Serial Number	Description	Qty.
1	10249	41-782-11	(0000000000-) Miniblock, Cylinder	1
	61783	41-004-05	(0000000000-) Gasket Set	1
	52198	41-755-17	(0000000000-) Gasket Set, with Seals	1
2		230125-S	(0000000000-) Shaft, Governor	1
3		231625	(0000000000-) Bearing, Ball	2
4		X-583-2	(0000000000-) Seal, Oil	1
5	52977	X-230-11	(0000000000-) Plug, Expansion	1
6		230007-S	(0000000000-) Guide, Valve	2
7		230170	(0000000000-) Insert, Exhaust Valve	1
8	42028	234866	(0000000000-) Bearing	1
9	42078	41-041-07	(0000000000-) Gasket, Bearing Plate	1
10		41-009-02	(0000000000-) Plate, Bearing	1
11		X-I76-1	(0000000000-) Screw, Hex Cap	4
12		X-583-1	(0000000000-) Seal, Front Oil	1
13	52178	41-014-15	(0000000000-) Crankshaft	1
14		41-015-07	(0000000000-) Head, Cylinder	1
15	10237	41-041-10	(0000000000-) Gasket, Head	1
16		220534	(0000000000-) Washer, Plain	5
17	52185	41-086-02	(0000000000-) Screw, Hex Cap	7
18	52180	41-038-14	(0000000000-) Dipstick	1
19	42091	41-153-01	(0000000000-) O-Ring	1
20		41-123-19	(0000000000-) Tube, Fill	1
21	52173	41-199-07	(0000000000-) Pan, Oil	1
22		X-75-28	(0000000000-) Plug, Pipe	1
23	37244	41-041-03	(0000000000-) Gasket, Pan	1
24		X-154-3	(0000000000-) Screw, Hex Cap Sems	4
25	38589	41-067-10	(0000000000-1601300007)	Rod, Connecting	1
25	42158	41-067-08	(1601300008-) Rod, Connecting	1
25	52184	41-067-11	(0000000000-1601300007)	Rod, Connecting, 0.010"	1
25	52183	41-067-09	(1601300008-) Rod, Connecting, 0.010"	1
26		41-874-05	(0000000000-1601300007)	Piston Assembly	1
26		41-874-10	(1601300008-) Piston Assembly	1
26		41-874-06	(0000000000-1601300007)	Piston Assembly, 0.003"	1
26	61822	41-874-11	(1601300008-) Piston Assembly, 0.003"	1
26	38443	41-874-07	(0000000000-1601300007)	Piston Assembly, 0.010"	1
26	61823	41-874-12	(1601300008-) Piston Assembly, 0.010"	1
26	38980	41-874-08	(0000000000-1601300007)	Piston Assembly, 0.020"	1
26	61824	41-874-13	(1601300008-) Piston Assembly, 0.020"	1
26	61820	41-874-09	(0000000000-1601300007)	Piston Assembly, 0.030"	1
26		41-874-14	(1601300008-) Piston Assembly, 0.030"	1
27	61821	230004	(0000000000-) Retainer, Piston Pin	2
28		232575	(0000000000-1601300007)	Ring Set, 0.003"	1
28	61747	41-108-01	(1601300008-) Ring Set, 0.003"	1
28		232576	(0000000000-1601300007)	Ring Set, 0.010"	1
28		41-108-02	(1601300008-) Ring Set, 0.010"	1
28		232577	(0000000000-1601300007)	Ring Set, 0.020"	1
28		41-108-03	(1601300008-) Ring Set, 0.020"	1
28		232578	(0000000000-1601300007)	Ring Set, 0.030"	1
28		41-108-04	(1601300008-) Ring Set, 0.030"	1

Fig. 2 – Camshaft and Valves Group



03195

Key	TENNANT Part No.	Kohler® Part No.	Engine Serial Number	Description	Qty.
1	61784	41-010-07	(0000000000-)	Camshaft Assembly	1
2	52204	47-089-01	(0000000000-)	Spring, Actuating	1
3		230293	(0000000000-)	Spacer, Camshaft 0.005"	1
3		230294	(0000000000-)	Spacer, Camshaft 0.010"	1
4	10216	41-380-03	(0000000000-)	Pin, Camshaft	1
5		52-139-09	(0000000000-)	Plug, Cup	1
6		230027	(0000000000-)	Valve, Exhaust	1
7		230008	(0000000000-)	Valve, Intake	1
8		230010	(0000000000-)	Spring, Intake Valve	1
9		41-755-10	(0000000000-)	Retainer Kit	2
10		230011	(0000000000-)	Retainer, Intake Spring	1
11	38863	230013	(0000000000-)	Tappet, Intake Valve	1
12		232777	(0000000000-)	Tappet, Exhaust Valve	1
13	52339	52-413-01	(0000000000-)	Rotator, Exhaust Valve	1
14		230168	(0000000000-)	Spring, Exhaust Valve	1

Fig. 3 – Air Intake Group

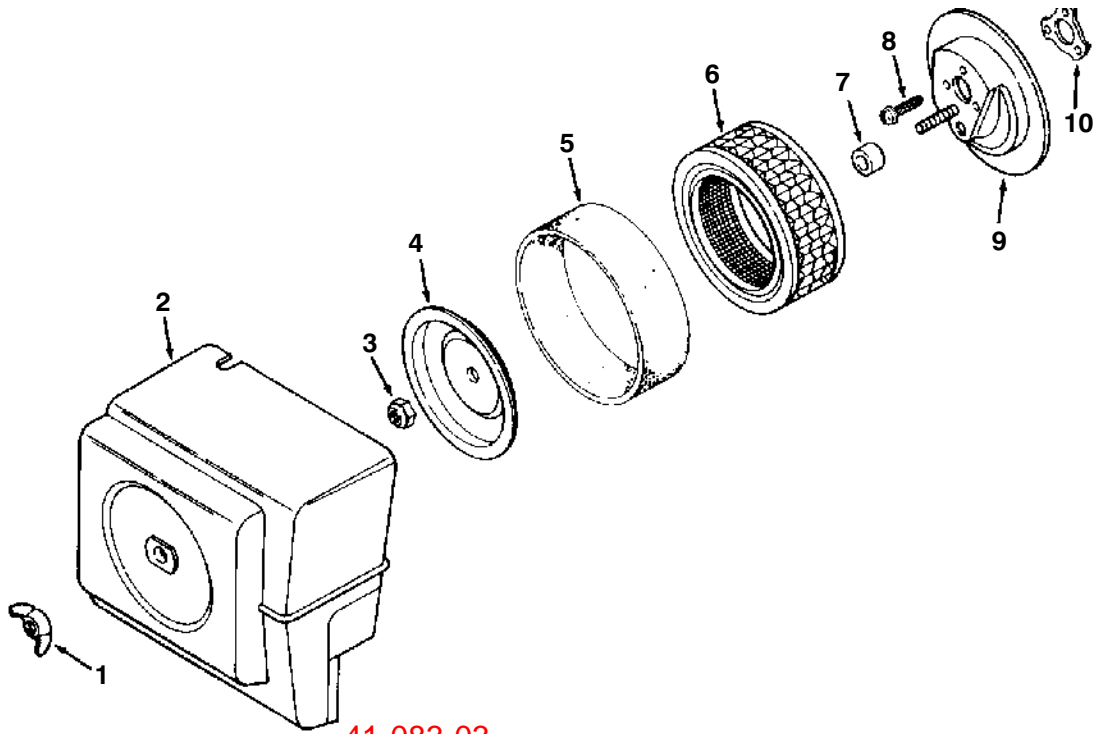

41-083-03

03193

Key	TENNANT Part No.	Kohler® Part No.	Engine Serial Number	Description	Qty.
1	52984	X-276-7	(0000000000-)	Nut, Wing	1
2		41-096-27	(0000000000-)	Cover, Air Cleaner	1
3	52189	41-100-04	(0000000000-)	Nut, Jam	1
4	52322	52-082-04	(0000000000-)	Cover, Element	1
5	06817	41-083-04	(0000000000-)	Element, Precleaner	1
6	06816	47-083-02	(0000000000-)	Element, Air Cleaner	1
7	10238	41-032-02	(0000000000-)	Seal	1
8		X-67-59	(0000000000-)	Screw, Washer Head	3
9	52186	41-743-02	(0000000000-)	Base, Air Cleaner	1
10		41-041-02	(0000000000-1824500011)	Gasket, Air Cleaner	1
10	38869	41-041-11	(1824500012-)	Gasket, Air Cleaner	1
		41-113-02	(0000000000-)	Decal, Air Cleaner	1

2355116

Fig. 4 – Baffles and Shroud Group

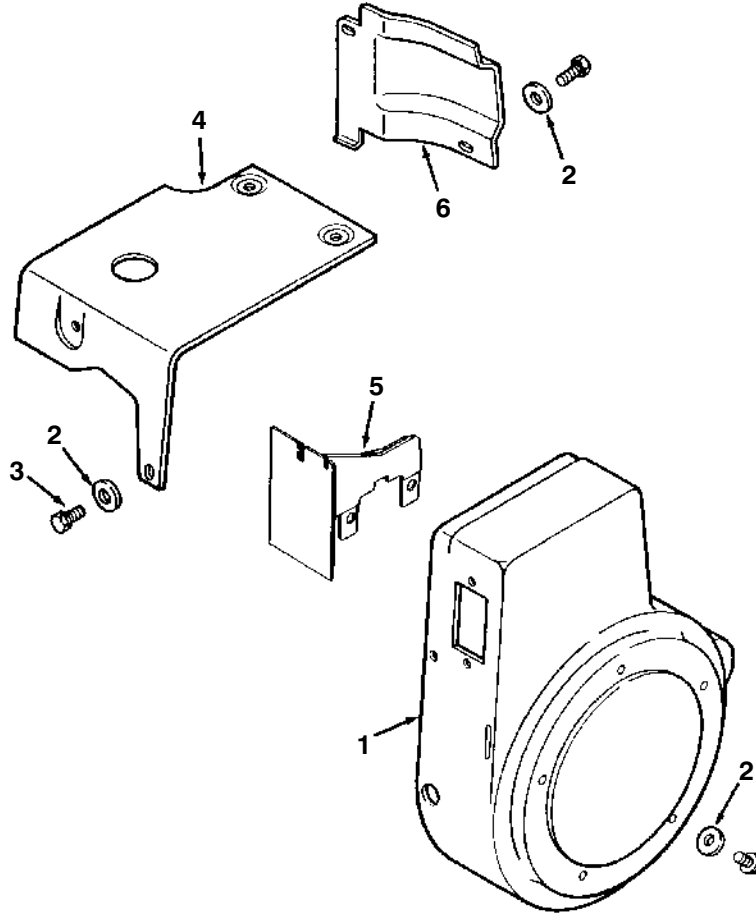

03192

Key	TENNANT Part No.	Kohler® Part No.	Engine Serial Number	Description	Qty.
1		41-027-47	(0000000000-)	Housing, Blower	1
2	52980	X-25-53	(0000000000-)	Washer, Plain	2
3		X-132-5	(0000000000-)	Screw, Hex Cap Sems	2
4		41-063-11	(0000000000-)	Baffle, Head	1
5		41-063-13	(0000000000-)	Baffle, Blower Housing	1
6		41-063-09	(0000000000-)	Baffle, Cylinder	1
		X-67-83	(0000000000-)	Screw, Hex Wash Head	4

Fig. 5 – Breather and Vent Group

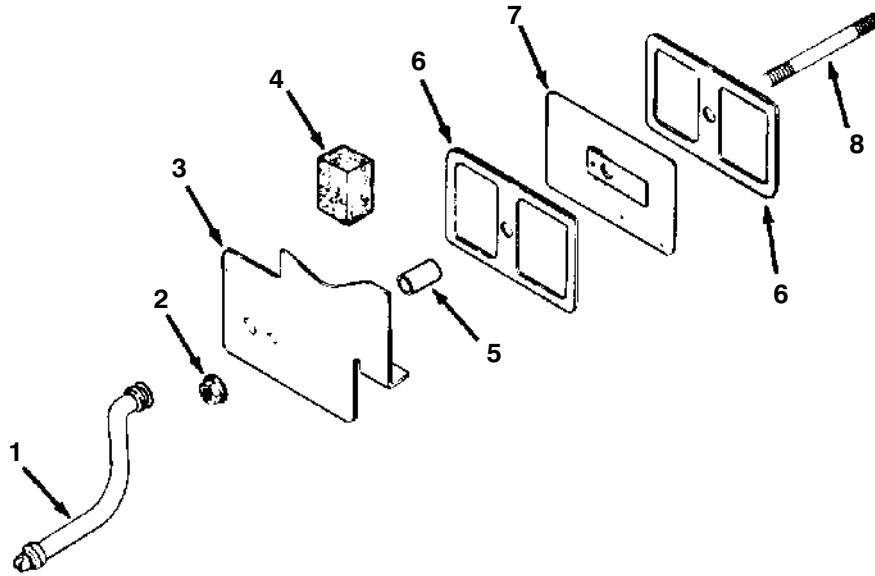

03194

Key	TENNANT Part No.	Kohler® Part No.	Engine Serial Number	Description	Qty.
1	52197	41-326-02	(0000000000-)	Hose, Breather	1
2	53022	X-799-1	(0000000000-)	Palnut	1
3		41-096-26	(0000000000-)	Cover, Valve	1
4		231419	(0000000000-)	Filter	1
5		230046	(0000000000-)	Seal, Breather	1
6		230048	(0000000000-)	Gasket, Valve Cover	2
7	38480	230066	(0000000000-)	Breather	1
8		230043	(0000000000-)	Stud, Valve Cover	1

Fig. 6 – Flywheel Group

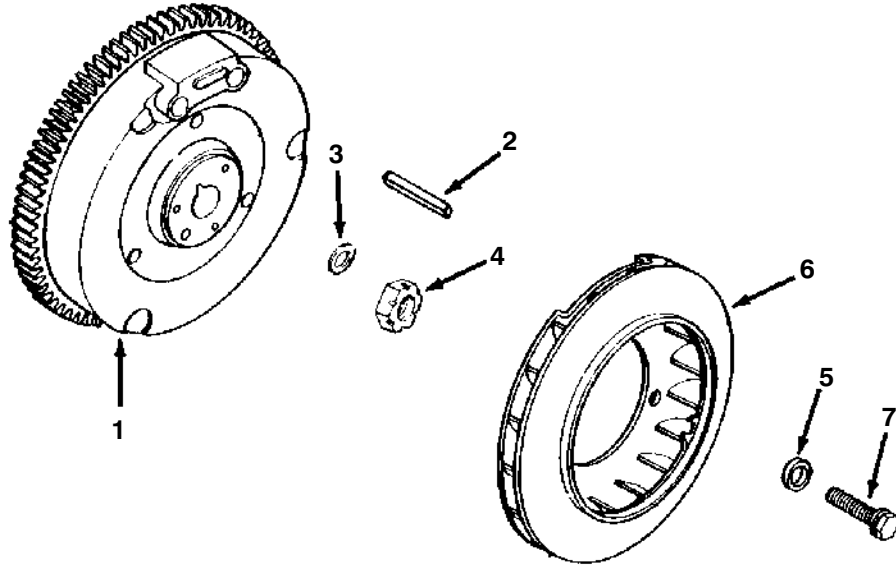

03190

Key	TENNANT Part No.	Kohler® Part No.	Engine Serial Number	Description	Qty.
1	52179	41-025-46	(0000000000-) Flywheel	1
2	10035	X-286-17	(0000000000-) Key, Square	1
3		X-25-15	(0000000000-) Washer, Plain	1
4	52932	25-100-02	(0000000000-) Nut, Hex	1
5		25-431-01	(0000000000-) Spacer	3
6		41-157-01	(0000000000-) Fan	1
7		25-086-14	(0000000000-) Screw, Hex Washer Head	3

Fig. 7 – Electric Start Group

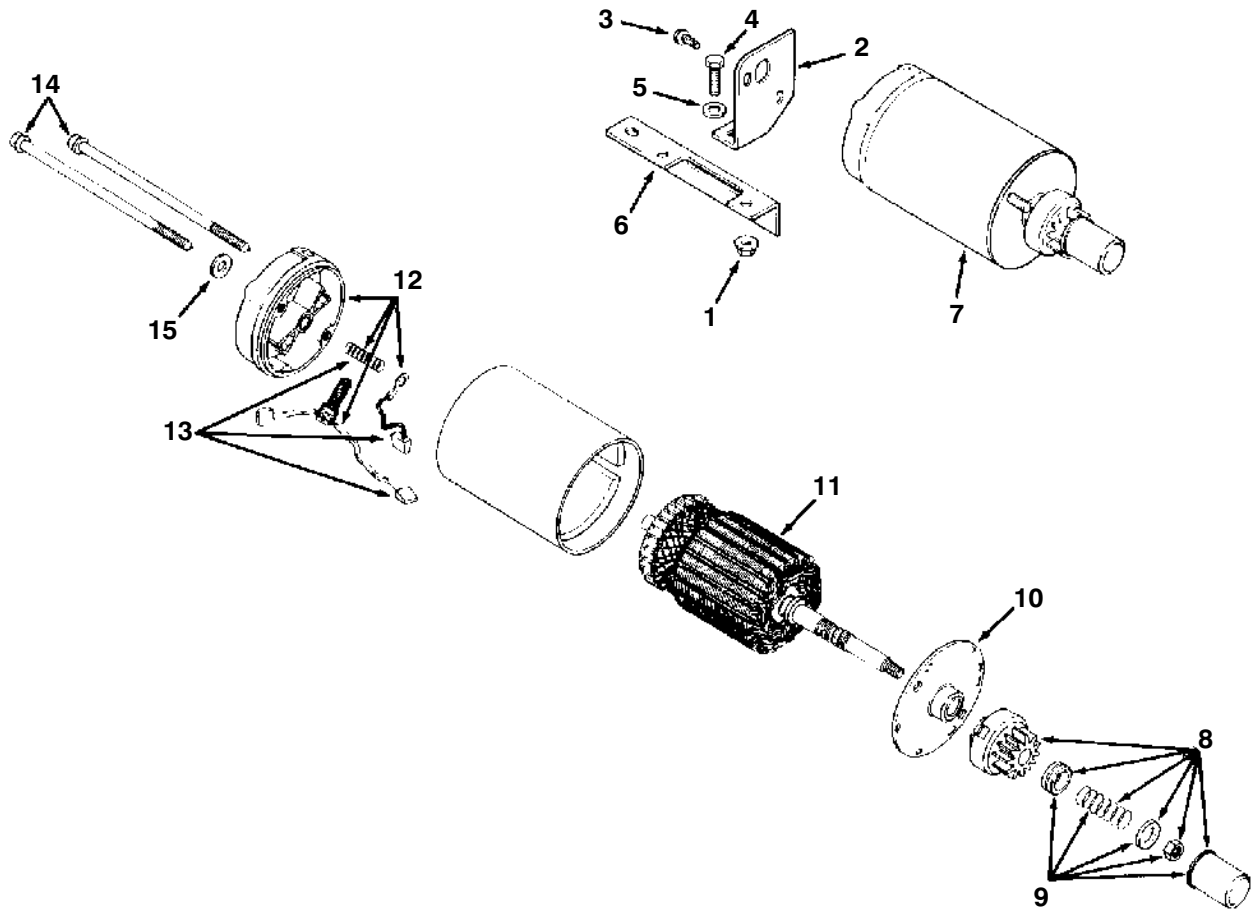

03191

Key	TENNANT Part No.	Kohler® Part No.	Engine Serial Number	Description	Qty.
1	53022	X-799-1	(0000000000-) Palnut	1
2	52190	41-120-06	(0000000000-) Brace, Starter Tail	1
3	53021	X-67-62	(0000000000-) Screw, Hex Washer Head	1
4	53020	X-5-1	(0000000000-) Screw, Hex	1
5	52980	X-25-53	(0000000000-) Washer, Plain	1
6	52192	41-126-25	(0000000000-) Bracket, Starter	1
∇ 7	10227	41-098-06	(0000000000-) Starter Assembly	1
▲∇ 8	37264	47-755-07	(0000000000-) Drive Kit	1
▲▲ 9	37708	47-755-13	(0000000000-) Drive Parts Kit	1
▲ 10	52195	41-227-03	(0000000000-) Cap, Drive End	1
▲ 11	52199	45-170-02	(0000000000-) Armature	1
▲∇ 12		41-227-04	(0000000000-) Cap, Commutator End	1
▲▲ 13	10250	82-755-28	(0000000000-) Brush Kit	1
▲ 14		41-086-19	(0000000000-) Bolt, Through	2
15	52980	X-25-53	(0000000000-) Washer, Plain	1
		25-450-03	(0000000000-) Tag, Caution	1

Fig. 8 – Governor Group

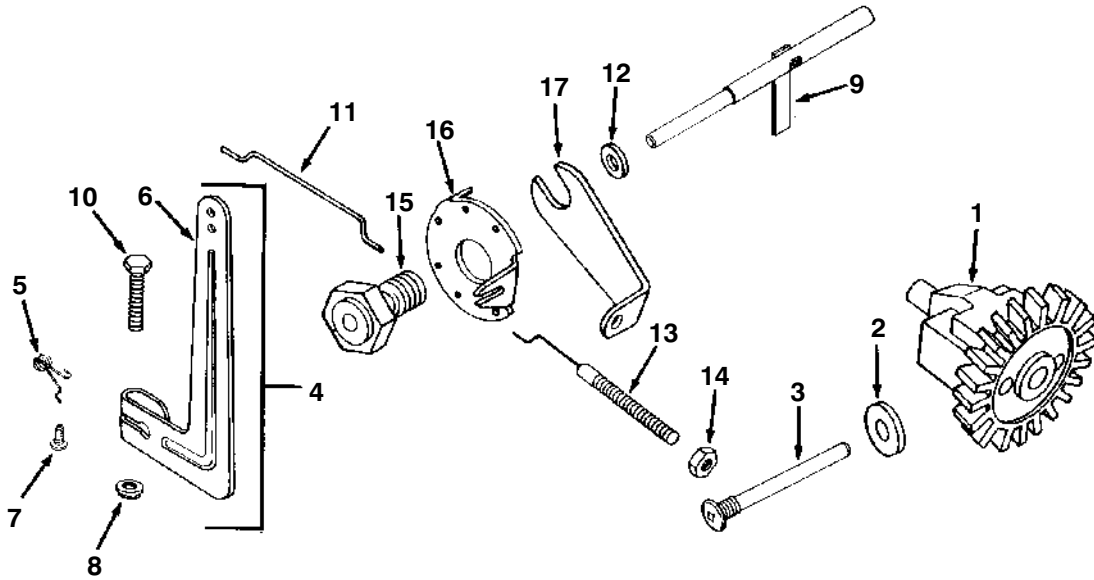

03187

Key	TENNANT Part No.	Kohler® Part No.	Engine Serial Number	Description	Qty.
1		A-235743-S	(0000000000-	Kit, Governor Gear	1
2	52979	X-25-12	(0000000000-	Washer, Plain	1
3		231355	(0000000000-	Pin, Governor Stop	1
4		A-234178	(0000000000-	Lever, Governor Assembly	1
5		232617	(0000000000-	Spring, Governor	1
6		232614	(0000000000-	Lever, Governor	1
7		X-67-46	(0000000000-	Screw, Hex Washer Head	1
8	53022	X-799-1	(0000000000-	Palnut	1
9		230540-S	(0000000000-	Shaft, Governor Cross	1
10		25-086-15	(0000000000-	Screw, Hex Cap Head	1
11	30197	230078	(0000000000-	Linkage, Governor (LPG)	1
		2507901	(0000000000-	Linkage, Governor (Gasoline)	1
		2515809	(0000000000-	Bushing, Connector (Gasoline)	2
12	52981	X-25-58	(0000000000-	Washer, Plain	1
13	10240	220239	(0000000000-	Arm, Governor	1
14		X-72-4	(0000000000-	Nut, Hex	2
15		230476	(0000000000-	Bushing, Governor Shaft	1
16	51481	230149	(0000000000-	Disc, Regulating	1
17	52191	41-126-16	(0000000000-	Bracket, Speed Control	1

Fig. 9 – Ignition Group

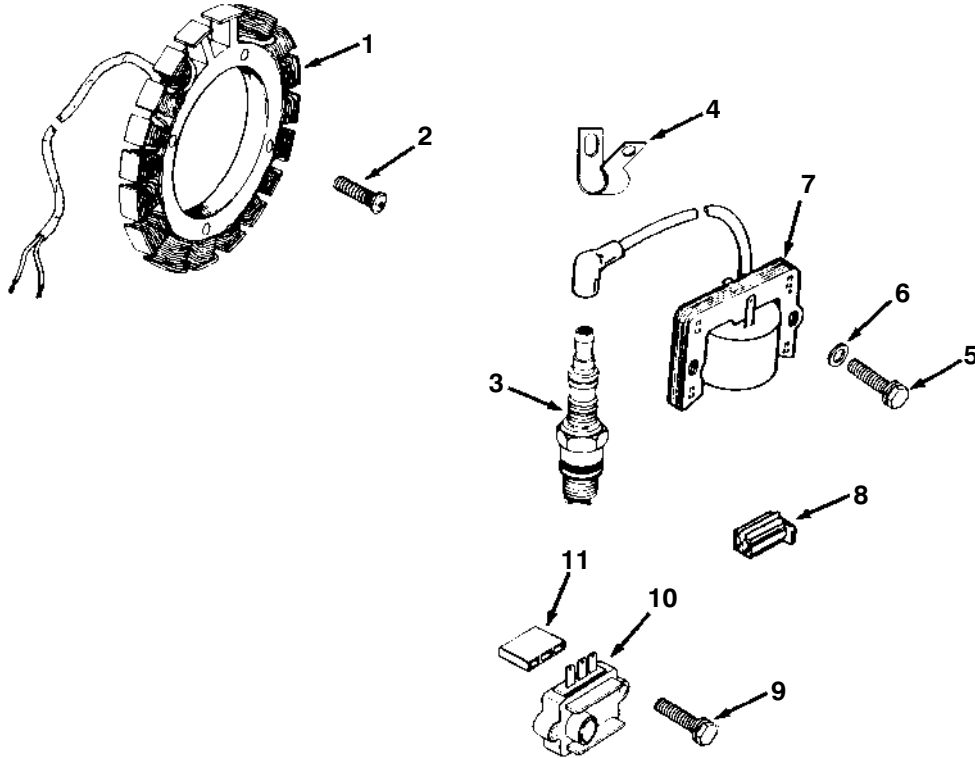

41-132-07

03186

Key	TENNANT Part No.	Kohler® Part No.	Engine Serial Number	Description	Qty.
1	10261	24-085-01	(0000000000-)	Stator, 15-A	1
2		X-778-1	(0000000000-)	Screw, Pan Head	4
3	30166	RJ49LM	(0000000000-)	Spark Plug	1
4		210281	(0000000000-)	Clip, High Tension	2
5		X-156-1	(0000000000-)	Screw, Hex Head Sems	2
6		X-25-79	(0000000000-)	Washer, Plain	2
7	10228	41-584-02 03	(0000000000-)	Module, Ignition	1
8		41-155-03	(0000000000-)	Connector	1
9		X-132-4	(0000000000-)	Screw, Sems Indented Hex	2
10	25905		(0000000000-xxxxxxxx)	Regulator Replacement Kit	1
10	25904	25-755-03	(xxxxxxxxxx-)	Regulator, Rectifier	1
11		236602	(0000000000-)	Connector	1
		41-518-33	(0000000000-)	Lead, Ground to Kill	1
		41-518-27	(0000000000-)	Lead, Rectifier Regulator	1

Fig. 10 – Carburetor Group, Gasoline

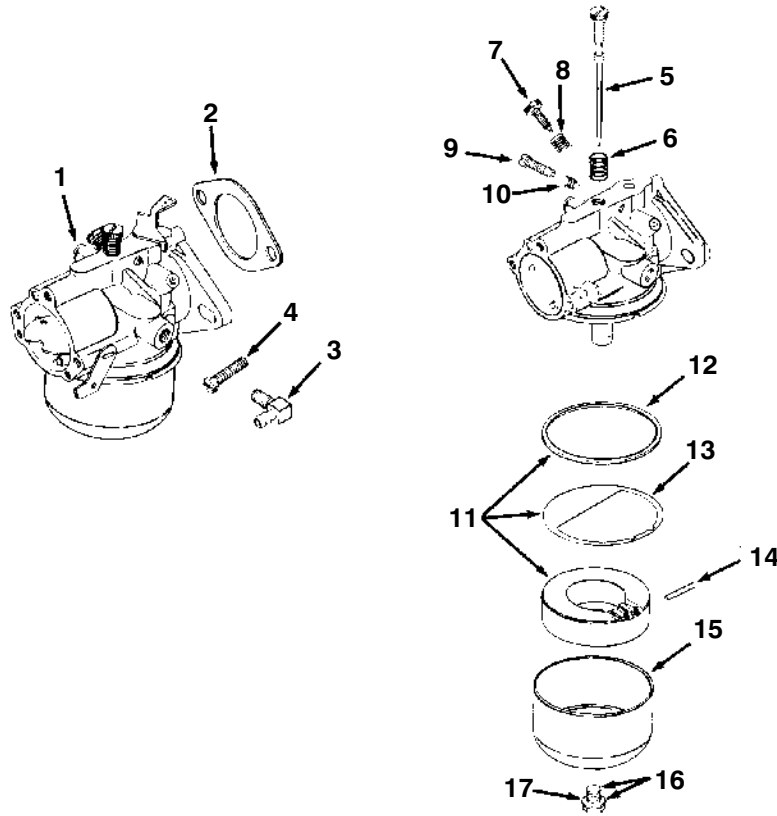

03183

Key	TENNANT Part No.	Kohler® Part No.	Engine Serial Number	Description	Qty.
▽ 1	10223	41-853-07	(0000000000-1824500011)	Carburetor Assembly (Replaced by 12963)	1
▲ 2	31055	210223	(0000000000-1824500011)	Gasket, Carburetor	1
▲ 3	10234	25-155-02	(0000000000-1824500011)	Fitting, Elbow	1
▲ 4		X-140-1	(0000000000-1824500011)	Screw, Slotted Head	2
▲ 5	38041	232635	(0000000000-1824500011)	Needle, Main Fuel	1
▲ 6	51395	200383	(0000000000-1824500011)	Spring, Main Fuel	1
▲ 7		200438	(0000000000-1824500011)	Needle, Idle Fuel	1
▲ 8	61759	200380	(0000000000-1824500011)	Spring, Idle Fuel	1
▲ 9		232556	(0000000000-1824500011)	Screw, Idle Speed	1
▲ 10		232555	(0000000000-1824500011)	Spring, Idle Speed	1
▲▽ 11	38708	25-757-03	(0000000000-1824500011)	Float Kit	1
▲▲ 12		200375	(0000000000-1824500011)	Gasket, Bowl	1
▲▲ 13		25-041-02	(0000000000-1824500011)	Gasket, Bowl Baffle	1
▲ 14	38494	200376	(0000000000-1824500011)	Pin, Float Hinge	1
▲ 15	51396	200418	(0000000000-1824500011)	Bowl, Fuel	1
▲ 16	38711	41-100-01	(0000000000-1824500011)	Screw, Bowl Retainer	1
▲ 17		200372	(0000000000-1824500011)	Washer, Sealing	1
	38571	25-757-01	(0000000000-1824500011)	Repair Kit, Carburetor	1
	61782	25-757-04	(0000000000-1824500011)	Repair Kit, Choke	1

Fig. 11 – Carburetor Group, Gasoline

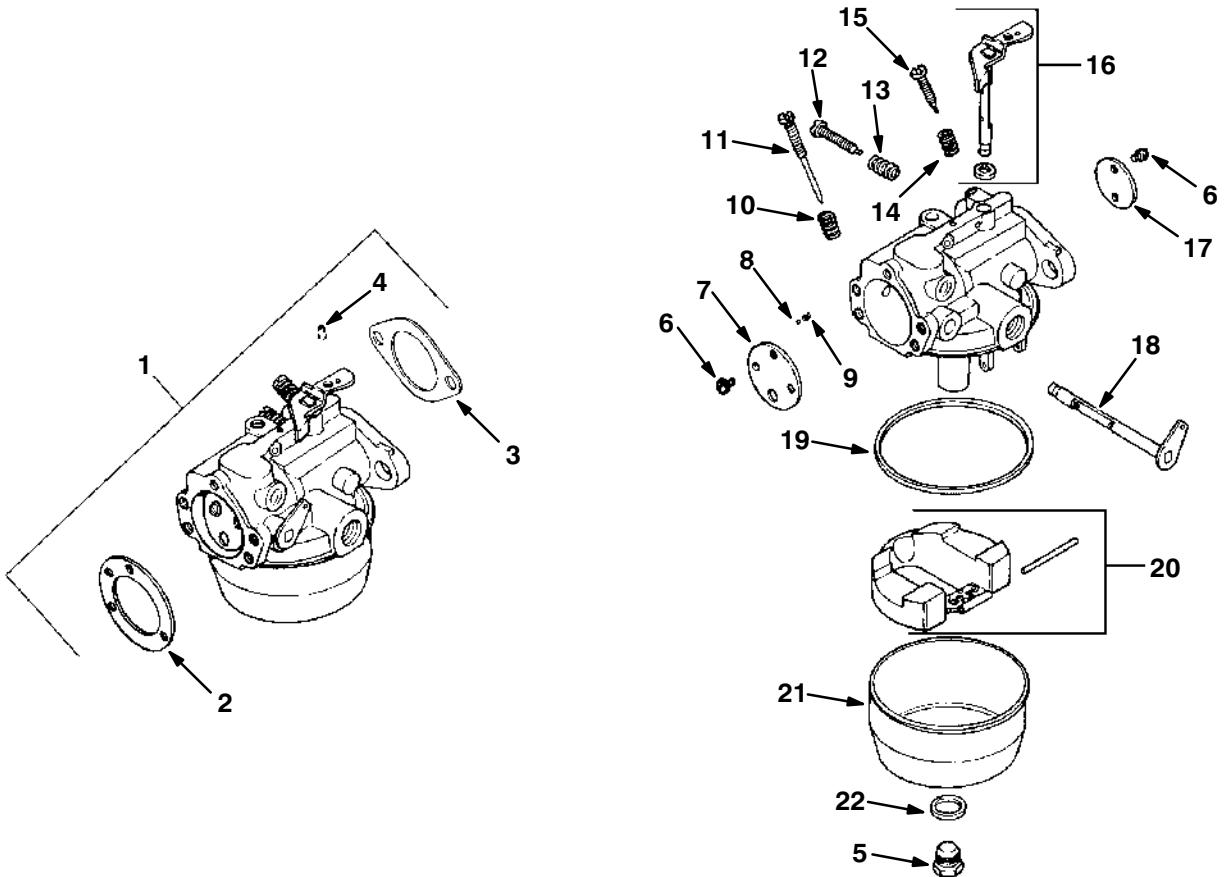

41 053 38

05435

Key	TENNANT Part No.	Kohler® Part No.	Engine Serial Number	Description	Qty.
▽ 1	12963	41-853-07	(1824500012-	Carburetor Assembly (with gaskets)	1
▲	25892	25-757-11	(1824500012-	Carburetor Repair Kit	1
▲ 2		41-041-11	(1824500012-	Gasket, Air Cleaner	1
▲ 3	31055	210223	(1824500012-	Gasket, Carburetor	1
▲ 4		25-158-08	(1824500012-	Bushing, Governor Linkage	2
▲ 5		25-100-05	(1824500012-	Screw, Bowl Retainer	1
▲ 6		25-086-27	(1824500012-	Screw, Throttle and Choke Plate	4
▲ 7		41-146-16	(1824500012-	Plate, Choke	1
▲ 8		25-194-02	(1824500012-	Ball, Choke Friction	1
▲ 9		25-089-06	(1824500012-	Spring, Choke Friction	1
▲ 10		25-089-02	(1824500012-	Spring, Main Fuel	1
▲ 11		25-368-03	(1824500012-	Needle, Main Fuel Adjusting	1
▲ 12		25-086-26	(1824500012-	Screw, Idle Speed Adjusting	1
▲ 13		25-089-04	(1824500012-	Spring, Idle Speed	1
▲ 14		25-089-02	(1824500012-	Spring, Idle Fuel	1
▲ 15		25-368-02	(1824500012-	Needle, Idle Fuel Adjusting	1
▲ 16	42003	41-144-18	(1824500012-	Shaft, Throttle (with lever and seal)	1
▲ 17		25-146-05	(1824500012-	Plate, Throttle	1
▲ 18		41-090-22	(1824500012-	Lever, Choke	1
▲ 19		25-041-04	(1824500012-	Gasket, Bowl	1
▲ 20		25-757-09	(1824500012-	Float Kit	1
▲ 21		25-104-01	(1824500012-	Bowl, Fuel	1
▲ 22		25-041-03	(1824500012-	Gasket, Bowl Retainer Screw	1

Fig. 12 – Fuel Pump Group

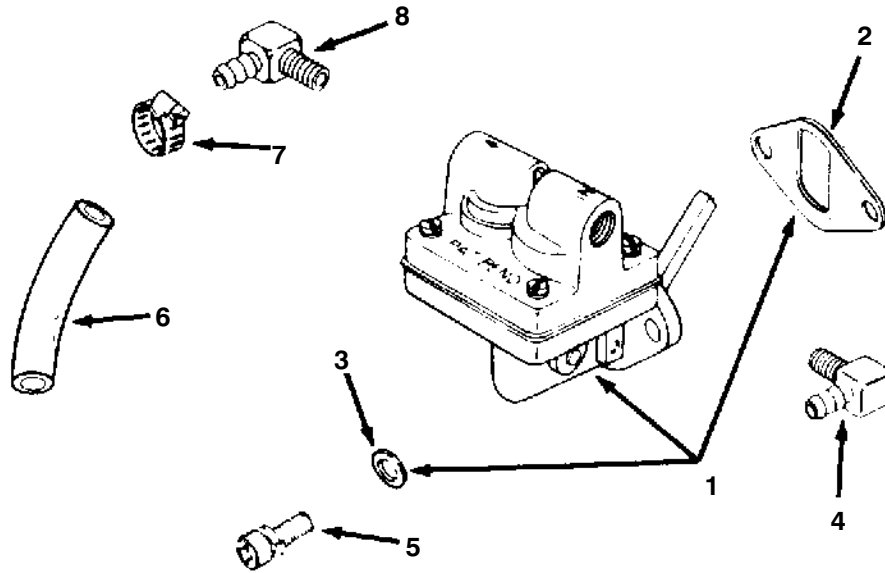

03188

Key	TENNANT Part No.	Kohler® Part No.	Engine Serial Number	Description	Qty.
▽ 1	10258	41-559-02	(0000000000-)	Pump, Fuel Assembly	1
▲ 2	04171	25-041-05	(0000000000-)	Gasket, Fuel Pump	1
▲ 3		X-25-63	(0000000000-)	Washer, Plain	2
4		X-391-11	(0000000000-)	Fitting, Elbow	1
5		X-174-2	(0000000000-)	Screw. Flat Head Machine	2
6		25-353-02	(0000000000-)	Line, Fuel	1
7		X-426-9	(0000000000-)	Clamp, Hose	2
8		25-155-02	(0000000000-)	Fitting, Elbow	1

Fig. 13 – Fuel Tank Group

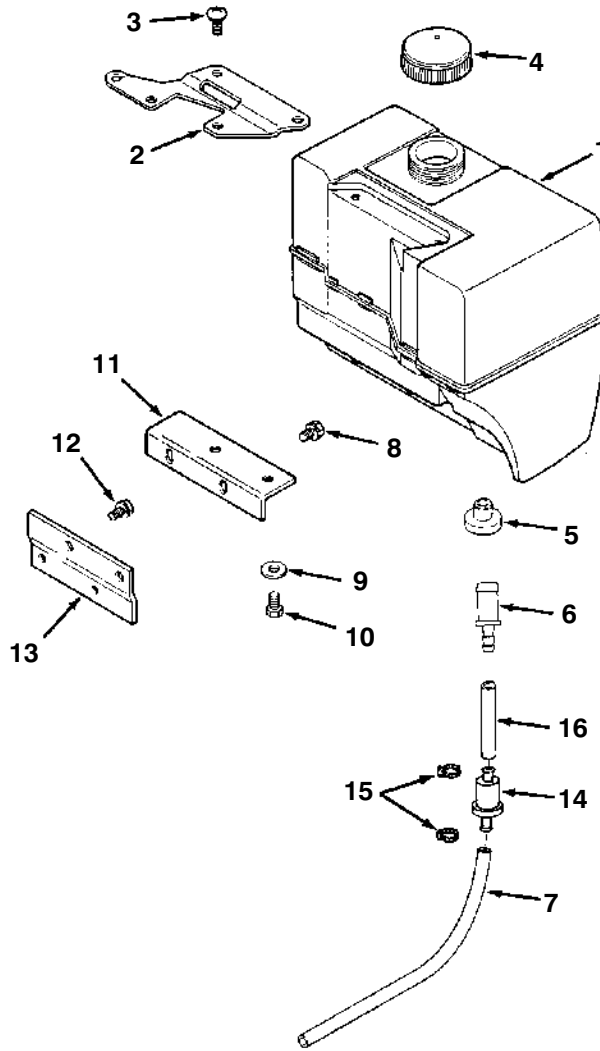

03189

Key	TENNANT Part No.	Kohler® Part No.	Engine Serial Number	Description	Qty.
1		41-065-14	(0000000000-	Tank, Fuel	1
2		41-126-26	(0000000000-	Bracket, Tank Support	1
3		41-086-18	(0000000000-	Screw, Pozidrive Truss Head	2
4	10235	25-173-03	(0000000000-	Cap, Fuel Tank	1
5		41-158-03	(0000000000-	Bushing, Fuel Tank	1
6		25-462-01	(0000000000-	Valve, Fuel	1
7		41-353-12	(0000000000-	Line, Fuel	1
8		X-132-1	(0000000000-	Screw, Hex Cap Sems	2
9		X-25-53	(0000000000-	Washer, Plain	2
10		X-5-1	(0000000000-	Screw, Hex Cap Head	2
11		41-126-29	(0000000000-	Bracket, Lower Tank	1
12		41-086-21	(0000000000-	Screw, Sems Indented Hex	2
13		41-126-30	(0000000000-	Bracket, Lower Tank	1
14	06818	25-050-02	(0000000000-	Filter, Fuel	1
15		25-237-01	(0000000000-	Clamp	2
16		41-353-10	(0000000000-	Line, Fuel	1

Fig. 14 – Fuel Pump Group, LPG

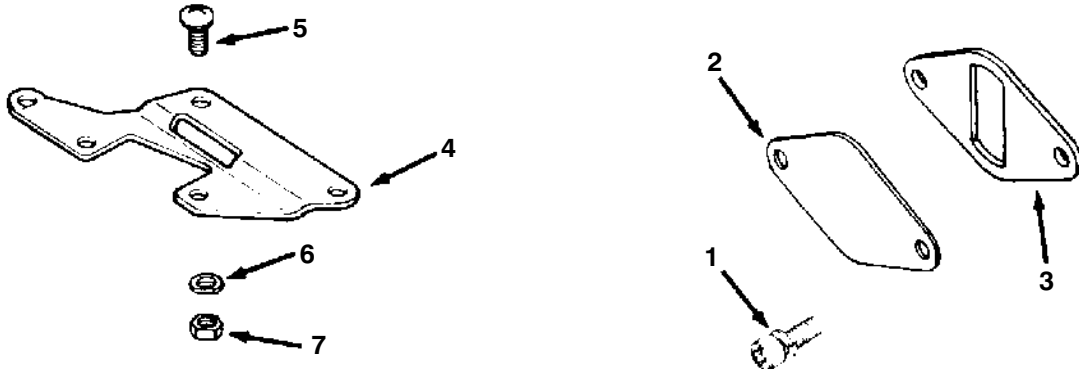

03181

Key	TENNANT Part No.	Kohler® Part No.	Engine Serial Number	Description	Qty.
1		X-132-6	(0000000000-) Screw, Hex Cap Sems	2
2	54229-1	240282	(0000000000-) Cover, Fuel Pump	1
3	04171	52-041-17	(0000000000-) Gasket, Fuel Pump	1
4	52193	41-126-26	(0000000000-) Bracket, Tank Support	1
5		41-086-18	(0000000000-) Screw, Pozidrive Truss Head	2
6		X-20-1	(0000000000-) Washer, Lock	2
7		X-81-1	(0000000000-) Nut	2

Fig. 15 – Carburetor Group, LPG

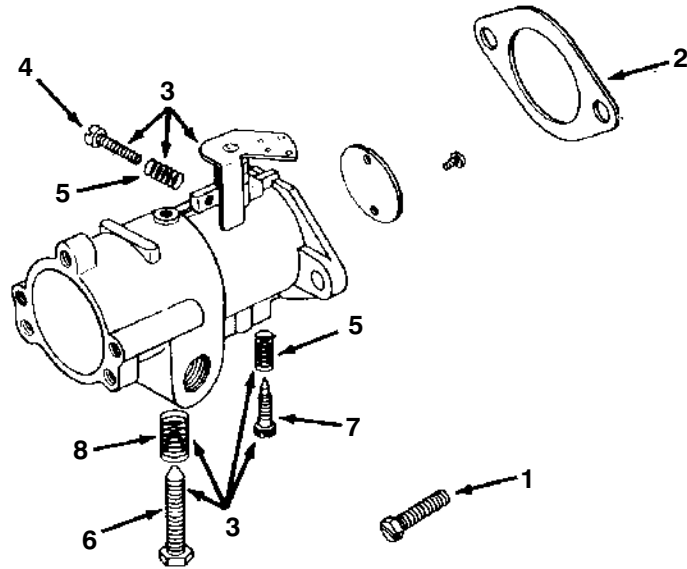

03182

Key	TENNANT Part No.	Kohler® Part No.	Engine Serial Number	Description	Qty.
1		X-140-1	(0000000000-) Screw, Slotted Head	2
2	31055	210223	(0000000000-) Gasket, Carburetor	1
▽ 3	10236	46-053-04	(0000000000-) Carburetor Assembly, LPG	1
▲ 4		234210	(0000000000-) Screw, Idle Stop	1
▲ 5	51555	234208	(0000000000-) Spring, Idle Screw	1
▲ 6		232694	(0000000000-) Screw, Load	1
▲ 7		234206	(0000000000-) Screw, Idle	1
▲ 8		234207	(0000000000-) Spring, Load Screw	1

SECTION 9

CONTENTS

	PAGE
PART NUMBER TO PAGE NUMBER CROSS REFERENCE LIST	9-2

CROSS REFERENCE

PART NUMBER TO PAGE NUMBER CROSS REFERENCE LIST

Part Number	Page Number	Part Number	Page Number
A-234178	8-10	01121	6-19
A-235743-S	8-10	01131	6-5
MM159	7-30	01132	6-19, 7-29
RJ19LM	8-11	01134	6-7, 6-13
SK1444	6-15	01136	6-7, 6-11
X-132-1	8-15	01138	6-16
X-132-4	8-11	01139	6-16
X-132-5	8-6	01141	6-16
X-132-6	8-16	01142	6-6, 6-9
X-140-1	8-12, 8-17	01144	6-7, 6-15
X-154-3	8-3	01150	6-7, 6-13
X-156-1	8-11	01154	7-20
X-174-2	8-14	01156	6-7, 6-11
X-20-1	8-16	01157	6-19
X-230-11	8-3	01166	6-5
X-25-12	8-10	01180	6-7
X-25-15	8-8	01188	6-20
X-25-53	8-6, 8-9, 8-15	01189	6-15, 7-21
X-25-58	8-10	01194	6-7
X-25-63	8-14	01195	6-6
X-25-79	8-11	01198	6-6
X-276-7	8-5	01199	6-7, 6-13
X-286-17	8-8	01200	6-18
X-391-11	8-14	01217	6-18
X-426-9	8-14	01224	7-21
X-5-1	8-9, 8-15	01225	7-16, 7-18
X-583-1	8-3	01234	6-5
X-583-2	8-3	01235	6-5
X-67-46	8-10	01236	6-16
X-67-59	8-5	01240	6-7, 6-13
X-67-62	8-9	01246	6-5
X-67-83	8-6	01247	6-5
X-72-4	8-10	01251	6-5
X-75-28	8-3	01255	6-20
X-778-1	8-11	01261	7-10, 7-11
X-799-1	8-7, 8-9, 8-10	01262	6-15
X-81-1	8-16	01266	7-25, 7-28
X-176-1	8-3	01271	6-6
00500-1	6-18	01272	6-19
00500-10	7-23	01274	6-7
00500-4	6-20	01280	6-7, 6-13
00500-6	6-7, 6-13	01283	6-15
00911	6-17, 7-7	01284	6-15
00960	6-20	01285	7-3
01040	7-28	01286	7-5, 7-13
01047	6-17	01288	6-18
01053	7-23	01306	6-21
01058	6-17	01314	6-15, 6-22, 6-23
01064	6-21	01316	6-19
01089	6-7, 6-13	01317	6-5
01096	6-20	01318	6-5
01103	6-7, 6-13	01319	6-21
01104	6-20	01320	6-21
01112	6-7, 6-13	01329	7-3
01113	6-7, 6-13	01330	7-14
01115	6-7, 6-13	01331	6-7
01119	6-7, 6-13	01334	7-7
01120	6-7, 6-13	01335	6-7, 6-9, 6-15, 6-21, 7-22

CROSS REFERENCE

Part Number	Page Number	Part Number	Page Number
01342	7-3	01615	7-15, 7-17
01343	7-3	01617	7-15
01344	7-7	01618	7-15, 7-17
01345	7-7	01621	7-3
01347	7-7	01622	7-3
01352	6-25	01628	7-5
01354	6-25	01633	7-5
01356	6-25	01636	7-8
01362	6-18	01637	7-10, 7-11, 7-16, 7-18
01364	6-22, 6-23	01638	7-21, 7-22
01365	6-7, 6-11	01639	7-5, 7-13
01366	6-7, 6-11	01640	7-5, 7-13
01392	7-15	01642	7-3
01393	7-16	01643	7-3
01398	7-15	01644	7-3
01413	7-5, 7-13	01654	7-17
01438	7-23	01657	6-2, 7-8
01439	7-23	01780	6-2, 7-8
01444	7-23	02221	6-20
01452	7-14	02250	6-15
01469	7-23	02371	6-25
01470	7-23	03292B	6-19
01471	7-23	03856	6-2, 7-8
01473	7-23	04057	7-15
01476	7-23	04060	7-15
01479	7-23	04171	8-14, 8-16
01482	7-21, 7-22	05579	7-17
01486	7-21	05584	7-17
01488	7-21	05594	7-17
01492	7-5, 7-13	06121	6-21, 7-15
01494	7-5, 7-13	06466	6-15
01495	7-3	06468	6-7
01498	7-7	06469	6-5
01499	7-5, 7-13	06473	6-7, 6-9
01500	6-17	06476	7-22
01502	7-8	06477	6-21
01504	7-3	06478	7-3
01506	7-23	06481	7-8
01507	7-7	06482	7-15
01508	7-7	06615	7-3
01510	7-7	06619	7-7
01511	7-7	06620	7-3
01513	6-17	06645	7-3
01517	7-7	06649	6-2
01520	7-5, 7-13	06651	6-17
01525	7-5, 7-13	06654	7-3
01532	7-7	06659	6-21
01534	7-5, 7-13	06660	6-21
01536	7-5, 7-13	06662	6-17
01554	7-23	06664	6-7, 6-13
01555	7-7	06665	7-14
01559	7-7	06666	7-14
01568	7-3	06732	6-2
01570	7-3	06733	7-20
01576	7-3	06735	7-21
01579	7-3	06741	7-15
01580	7-3	06762	7-5, 7-13
01584	7-3	06796	7-5
01595	7-14	06800	7-3
01613	7-15, 7-17	06813	7-28

CROSS REFERENCE

Part Number	Page Number	Part Number	Page Number
06815	7-28	10235	8-15
06816	6-2, 8-5	10236	8-17
06817	6-2, 8-5	10237	8-3
06818	6-2, 8-15	10238	8-5
06826	7-28	10240	8-10
07259	6-16	10249	8-3
07316-15	6-17	10250	8-9
08036	6-7	10258	8-14
08037	6-7, 6-13	10261	8-11
08039	7-21	10352	6-20
08041	6-7	10357	7-14
08057	6-2, 6-5	10361	7-7
08067	7-3	10362	6-20
08076	7-19	10368	7-24
08077	7-21, 7-22	10372	7-24
08078	6-6, 6-11, 7-11, 7-16, 7-18, 7-19	10378	7-24
08086	6-6	10379	7-24
08087	6-5	10381	7-24
08091	7-5, 7-13	10383	7-3
08092	7-5, 7-13	10386	7-7
08093	7-5, 7-13	10387	7-3
08142	6-18	10632-12	6-6, 6-11
08143	6-20	10632-14	6-7, 6-13
08145	6-18	10752-2	7-27
08147	6-16	10752-3	7-27
08152	6-18	10756	6-15
08155	6-17	11398	6-7, 6-13
08156	6-5	11442-1	6-15
08157	6-21	11531	7-5, 7-10, 7-11, 7-13, 7-16, 7-18
08158	6-25	12053	7-3
08703	6-2, 6-5	12063	6-5
09338	6-22, 6-23	12065	6-6
09349	6-25	12075	7-5
09362	6-22	12077	7-5
09363	7-29	12078	7-3
09367	6-9, 6-15	12081	7-3
09400	6-11	12082	7-21, 7-22
09408	6-11	12764	6-19
09473	6-11	12768	6-19
09480	6-5	12769	6-19
09481	7-29	12774	6-22
09482	7-29	12955	6-7, 6-13
09483	7-29	12963	8-13
09484	7-29	12964	6-9, 6-15, 7-22
09486	6-9	12966	6-7
09487	6-15, 7-22	12984	6-7
09494	6-9	12985	6-15
10035	8-8	12990	6-18
10134	6-7, 6-11	14330	6-7, 6-16, 7-7
10135	6-7, 6-11	14331	7-7
10216	8-4	15173	6-17
10218	7-5, 7-13	15687	6-7, 6-13
10223	8-12	16376	6-7, 6-13
10224	6-20	16934	6-20
10226	6-5	17461	7-9
10227	8-9	18125	6-17
10228	8-11	18136	6-16
10231	6-27	18276	6-17
10234	8-12	18645	6-5

CROSS REFERENCE

Part Number	Page Number	Part Number	Page Number
19979	6-7, 6-11	23481	6-20
200372	8-12	234866	8-3
200375	8-12	23498	6-20
200376	8-12	23524-3	7-23
200380	8-12	236602	8-11
200383	8-12	24-085-01	8-11
200418	8-12	240282	8-16
200438	8-12	25-041-02	8-12
20050	6-17	25-041-03	8-13
20215	7-5, 7-13	25-041-04	8-13
20267	7-5, 7-13	25-041-05	8-14
20634	6-18, 6-21	25-050-02	8-15
210223	8-12, 8-13, 8-17	25-086-14	8-8
210281	8-11	25-086-15	8-10
21570	6-23	25-086-26	8-13
220239	8-10	25-086-27	8-13
220534	8-3	25-089-02	8-13
22297	7-5, 7-13	25-089-04	8-13
22308-3	6-15	25-089-06	8-13
22324	6-15	25-100-02	8-8
22328	6-7	25-100-05	8-13
230004	8-3	25-104-01	8-13
230007-S	8-3	25-146-05	8-13
230008	8-4	25-155-02	8-12, 8-14
230010	8-4	25-158-08	8-13
230011	8-4	25-173-03	8-15
230013	8-4	25-194-02	8-13
230027	8-4	25-237-01	8-15
230043	8-7	25-353-02	8-14
230046	8-7	25-368-02	8-13
230048	8-7	25-368-03	8-13
230066	8-7	25-431-01	8-8
230078	8-10	25-450-03	8-9
230125-S	8-3	25-462-01	8-15
230149	8-10	25-755-03	8-11
230168	8-4	25-757-01	8-12
230170	8-3	25-757-03	8-12
230293	8-4	25-757-04	8-12
230294	8-4	25-757-09	8-13
230476	8-10	25-757-11	8-13
230540-S	8-10	2507901	8-10
231355	8-10	2515809	8-10
231419	8-7	25312	7-26
231625	8-3	25656	7-15, 7-17
23217	6-17	25887	6-18
232555	8-12	25892	8-13
232556	8-12	25904	8-11
232575	8-3	25905	8-11
232576	8-3	25920	6-21
232577	8-3	25921	6-7, 6-13
232578	8-3	26015	7-15
232614	8-10	26103	6-16
232617	8-10	26212	6-17
232635	8-12	26239	6-17, 7-7
232694	8-17	26414	6-7, 6-11, 7-11, 7-16, 7-18,
232777	8-4		7-19
234206	8-17	26496	6-15
234207	8-17	26509	6-17
234208	8-17	27048	6-15
234210	8-17	27055	7-28

CROSS REFERENCE

Part Number	Page Number	Part Number	Page Number
28002	6-3	29005	6-16
28006	6-3	29006	6-3
28006N	6-3	29406	6-3, 7-9
28007P	6-3	29408	6-3
28010	6-17, 6-18	29545	6-7, 6-11, 7-24
28014A	6-18	29585	7-9
28025	6-2, 6-5	29586	7-9
28026	6-2, 6-5	29592	7-9
28041	6-17	29653	7-8
28061	6-18	29664	7-5, 7-13
28066	6-16	29982	6-5
28071	6-5	29991	6-22
28072	6-2, 6-5	30147	6-18
28074	6-16	30148	6-18
28078	6-17	30166	6-2, 8-11
28081	6-2, 6-5, 6-19	30169	6-21
28084	6-17	30172	6-27
28096N	6-3	30174	6-18
28096P	6-3	30175	6-18
28121	6-17	30181	6-15
28144	6-17	30182	6-15
28168	6-17	30197	8-10
28172	6-3	30201	6-6
28194	6-17	30205	6-13
28195	6-17	30246	7-5, 7-13
28223	6-17	31025	6-19
28234	6-3	31037	7-9
28235	6-3	31039	7-9
28250	6-2, 6-5	31055	8-12, 8-13, 8-17
28272	6-18	31172	6-21
28277-1	6-2, 6-5	31173	6-21
28277-2	6-2, 6-5	31204	6-22, 6-23
28281	7-23	32490	7-17
28311	7-28	32557	7-20
28387	6-17	33285	6-22, 6-23
28388	6-17	33806	7-21, 7-22
28499	6-5	34810	6-22, 6-23
28546	6-18	35927	7-23
28574	7-3	37244	8-3
28660	6-3	37264	8-9
28712	6-17	37666	6-15
28714	6-17	37669	6-15
28755	6-20	37673	6-15
28840	6-17	37708	8-9
28841	6-16	38041	8-12
28845A	6-17	38443	8-3
28849-1	6-17	38480	8-7
28850A	6-16	38494	8-12
28852	6-17	38571	8-12
28862	6-16	38589	8-3
28865	6-18	38708	8-12
28867	6-17	38711	8-12
28868	6-17	38863	8-4
28949	6-17	38869	8-5
28950-2	7-5, 7-13	38977	7-30
28973	6-7, 6-11	38980	8-3
28976	6-17	39021	7-23
28977	6-17	39270	6-7, 6-11
28979	6-17	39330	7-14
28988-1	6-5, 7-28	39338	7-14

CROSS REFERENCE

Part Number	Page Number	Part Number	Page Number
39562	6-16	41-380-03	8-4
39778	7-21	41-518-27	8-11
40352	6-16	41-518-33	8-11
41-004-05	8-3	41-559-02	8-14
41-009-02	8-3	41-584-02	8-11
41-010-07	8-4	41-743-02	8-5
41-014-15	8-3	41-755-10	8-4
41-015-07	8-3	41-755-17	8-3
41-025-46	8-8	41-782-11	8-3
41-027-47	8-6	41-853-07	8-12, 8-13
41-032-02	8-5	41-874-05	8-3
41-038-14	8-3	41-874-06	8-3
41-041-02	8-5	41-874-07	8-3
41-041-03	8-3	41-874-08	8-3
41-041-07	8-3	41-874-09	8-3
41-041-10	8-3	41-874-10	8-3
41-041-11	8-5, 8-13	41-874-11	8-3
41-063-09	8-6	41-874-12	8-3
41-063-11	8-6	41-874-13	8-3
41-063-13	8-6	41-874-14	8-3
41-065-14	8-15	41186	6-19
41-067-08	8-3	41285	6-9
41-067-09	8-3	41288	6-21
41-067-10	8-3	41292	6-20
41-067-11	8-3	41293	7-14
41-083-04	8-5	41294	7-11, 7-18, 7-19
41-086-02	8-3	41305	6-5
41-086-18	8-15, 8-16	41306	7-29
41-086-19	8-9	41620	6-19
41-086-21	8-15	42003	8-13
41-090-22	8-13	42028	8-3
41-096-26	8-7	42078	8-3
41-096-27	8-5	42091	8-3
41-098-06	8-9	42158	8-3
41-100-01	8-12	42173-1	7-21
41-100-04	8-5	43242	7-3, 7-5
41-108-01	8-3	43363	7-15
41-108-02	8-3	43454	7-7
41-108-03	8-3	43516A	7-3
41-108-04	8-3	43611	7-7, 7-15
41-113-02	8-5	44078	6-22, 6-23
41-120-06	8-9	44893	6-21
41-123-19	8-3	44906	7-7
41-126-16	8-10	45-170-02	8-9
41-126-25	8-9	45086	7-7
41-126-26	8-15, 8-16	45089	7-7
41-126-29	8-15	45154	6-3
41-126-30	8-15	45937	7-5, 7-13
41-144-18	8-13	45938-1	7-5, 7-13
41-146-16	8-13	46-053-04	8-17
41-153-01	8-3	46139	7-11, 7-16, 7-18, 7-19
41-155-03	8-11	46140	7-11, 7-16, 7-18, 7-19
41-157-01	8-8	46236	7-3, 7-19
41-158-03	8-15	46820	6-7, 6-13, 6-20
41-199-07	8-3	46938	7-26
41-227-03	8-9	47-083-02	8-5
41-227-04	8-9	47-089-01	8-4
41-326-02	8-7	47-755-07	8-9
41-353-10	8-15	47-755-13	8-9
41-353-12	8-15	47037	6-2

CROSS REFERENCE

Part Number	Page Number	Part Number	Page Number
47069	6-20	52508	6-11
47807	7-28	52932	8-8
47935	6-15	52977	8-3
48769	6-13	52979	8-10
48771	6-15	52980	8-6, 8-9
49250	6-15	52981	8-10
49266	7-10, 7-11, 7-16, 7-18, 7-19	52984	8-5
49302	7-15	53020	8-9
49351-3	7-5, 7-13	53021	8-9
49708	6-17	53022	8-7, 8-9, 8-10
50711	6-5	53395-4	6-15
50744	6-9	53400-1	6-15
50775	7-29	53400-4	6-15
50806	6-26	53400-5	6-15
50821	6-11	53461-2	7-17
50829	6-23	54121	6-21
50832	6-9, 6-15, 7-22	54179	6-15
50835	6-9, 6-15, 7-22	54229-1	8-16
50843	6-28	54396	6-7, 6-13
50894	6-9, 6-15, 7-22	55130	6-21
50896	7-29	55762	6-7, 6-13
50909	6-11	56390	6-15
50910	6-11	57452	6-15, 7-10, 7-11
50913	6-28	57496	6-17, 6-18, 7-23
50930	7-29	57751	6-22, 6-23
50931	6-5	57803	6-22, 6-23
50936	6-11	57889	7-7
50938	6-5	58311	6-11
51137	6-18	58494	6-21
51395	8-12	59118-7	6-22, 6-23
51396	8-12	60027	6-2
51408-1	6-25	60040	7-22
51481	8-10	60470	6-20
51555	8-17	60595	7-3
51787	6-19, 7-15	61064	6-15, 7-22
52-041-17	8-16	61065	6-15, 7-22
52-082-04	8-5	61066	6-9
52-139-09	8-4	61067	6-9
52-413-01	8-4	61078	7-17
52173	8-3	61086	7-29
52178	8-3	61087	7-29
52179	8-8	61100	7-17
52180	8-3	61119	7-29
52183	8-3	61123	6-19
52184	8-3	61289	6-18
52185	8-3	61291	6-18
52186	8-5	61322	6-5
52189	8-5	61323	7-28
52190	8-9	61324	6-5
52191	8-10	61325	7-28
52192	8-9	61326	6-5
52193	8-16	61327	6-5
52195	8-9	61414	6-18
52197	8-7	61668	7-17
52198	8-3	61747	8-3
52199	8-9	61759	8-12
52204	8-4	61782	8-12
52322	8-5	61783	8-3
52339	8-4	61784	8-4
		61820	8-3

Part Number	Page Number
61821	8-3
61822	8-3
61823	8-3
61824	8-3
62170-1	6-7
63034	7-8
63038	7-8
63266	6-22
63310	7-5, 7-13
63327	7-8
63329	7-8
63785	7-23, 7-24
63967	6-2, 7-8
64595	6-21
64730	6-22, 6-23
64757	6-7, 6-9, 6-15, 7-22
65357	7-17
65359	7-17
65360	7-17
65375	6-21
65548	6-5
67004	7-15
69582	6-11
70314	6-11
70315	6-11
70316	6-11
70320	6-23
70323	6-23
70326	6-13
75774	7-7
76426	7-5, 7-13
78556	7-22
78557	7-22
82-755-28	8-9
82733	6-20
82747	6-6, 7-23
85159	7-30
87246	6-11
87299	6-20
87337	7-5, 7-13
87546	6-20
87550	6-21
94149	6-17
94150	6-17
94413	6-17

Fold along dotted lines

Tape here



NO POSTAGE
NECESSARY
IF MAILED
IN THE
UNITED STATES

BUSINESS REPLY MAIL
FIRST CLASS MAIL PERMIT NO. 94 MINNEAPOLIS, MN

POSTAGE WILL BE PAID BY ADDRESSEE

TENNANT COMPANY

Technical Publications #15
701 North Lilac Drive
P.O. Box 1452
Minneapolis, MN 55440-9947



Fold along dotted lines

Tape here



NO POSTAGE
NECESSARY
IF MAILED
IN THE
UNITED STATES

BUSINESS REPLY MAIL
FIRST CLASS MAIL PERMIT NO. 94 MINNEAPOLIS, MN

POSTAGE WILL BE PAID BY ADDRESSEE

TENNANT COMPANY

Technical Publications #15
701 North Lilac Drive
P.O. Box 1452
Minneapolis, MN 55440-9947



TENNANT COMPANY SERVICE LITERATURE AVAILABLE...

A variety of information is available to you in forms to suit your needs. The following is a list of those publications that relate to the Model 186 family of machines:

Machine Model	Publication	Form	TENNANT Part No.
186	Operation, Maintenance, and Parts Manual	Printed	MM159
186E	Operation, Maintenance, and Parts Manual	Printed	MM160
186	Operation, Maintenance, and Parts Manual	Microfiche	85159
186E	Operation, Maintenance, and Parts Manual	Microfiche	85160
186	Operator Handbook	Printed	MM163
186E	Operator Handbook	Printed	MM163
186	Kolher® M8 Engine Service Manual	Printed	38977

Keep your manuals in a safe, convenient location for your future reference in order to operate, maintain, and order repair parts for your machine. Everyone who operates, maintains, or purchases parts for the machine should have easy access to a copy of the manual.

To get pricing information or to order copies of these publications, contact your nearest Tennant Company parts warehouse, distributor, or sales representative.

MODEL 186/186E

ATTENTION: READ BEFORE CONNECTING SOLUTION CONTROL CABLE.

When connecting the two piece solution control cable, the two ends should mate easily.

If twisting is required to get a good connection, loosen the valve swivel screw and allow the cable to relax. Connect the cables and tighten the swivel screw.

NOTE: Be sure that the valve lever does not move when loosening and tightening the swivel screw.