



Electronic Service Manuals

This electronic document is provided as a service to our customers. We do not create the contents of the information contained in this document. Should you have detailed questions pertaining to the information contained in this document, you may contact Michco, or the manufacturer which provided the original information in this electronic deliverable. Michco's only part in this electronic deliverable was the electronic assembly process. By providing this manual on line we are not guaranteeing parts availability.

You may contact Michco through the following methods:

Phone (517) 484-9312 or (800) 331-3339

2011 N. High St. -- Lansing, Michigan -- 48906

Fax: (517) 484-9836

Email: CustServe@Michco.com

Web site: www.Michco.Com

Parts Web site: www.FloorMachineParts.Com

Order Parts on Line at:

www.FloorMachineParts.Com

Directly to Parts & Service:

By Email: **Shop@Michco.com**

By Fax: (517) 702-2041

By Voice: Use numbers above.

Serving the Cleaning Industry Since 1922

Notice: All copyrighted material remains property of original owners, all trademarks are property of respective owners. Manuals are subject to Manufacturer's reproduction limitations. Originals or reproductions were provided by manufacturers through a request. We make no warranty as to the correctness of information provided in this document and you assume all risk. By placing these manuals on line we are not declaring our corporation to be an manufacturer authorized dealer or provider, please check our web site for authorized manufacturers we represent.

Minuteman[®]
Parker[®]

Model: TE9036

Trailette

OPERATION

SERVICE

PARTS

CARE

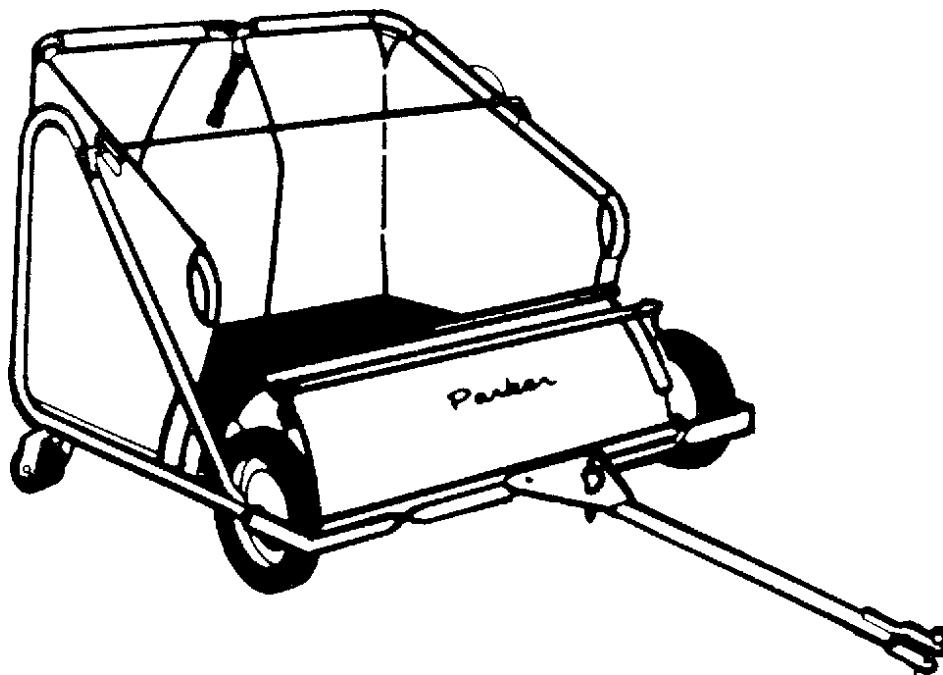

TABLE OF CONTENTS

CAUTION	1
ASSEMBLY	2-3
OPERATING INSTRUCTIONS	4-7
PINION REINSTALLATION (MANUAL SWEEPER)	8
SWEEPER UNIT ASSEMBLY	9
FRAME ASSEMBLY	10
BASKET ASSEMBLY	11
WARRANTY	BACK COVER

CAUTION

- This sweeper is not designed to haul people, animals or equipment. Severe damage to the sweeper and possible injury to people or animals may result if this warning is ignored.
- The basket has been designed for holding a large capacity of dry grass clippings. When grass clippings are wet or freshly cut, caution must be exercised on the amount picked up. If the basket is overloaded it will make dumping difficult.
- When basket is empty caution must be taken on rough (uneven) terrain. Travel slowly to prevent possible upsetting of the sweeper (tipping forward) when moving over gravel driveways, rutted turf, curb areas, bits of broken tree limbs, twigs, mole runs or other interference. Traveling too fast over rough areas may cause the sweeper wheels to be blocked causing the sweeper to upset.

DANGER

- Do not hold dumping rope in hand while towing. Secure loose end to tractor behind operator. Do not allow rope to contact brushes, as it may become tangled in the reel shaft causing damage to the unit and possible injury to the operator.

ASSEMBLY INSTRUCTIONS

CAUTION: FAILURE TO OBSERVE SAFETY INSTRUCTIONS MAY RESULT IN SERIOUS INJURY

FRAME ASSEMBLY

Your sweeper was inspected and packaged at the factory and will require a minimum of time to complete the assembly. Remove the two casters from the hitch yoke. You will need these bolts and nuts to assemble the hitch plate on the yoke.

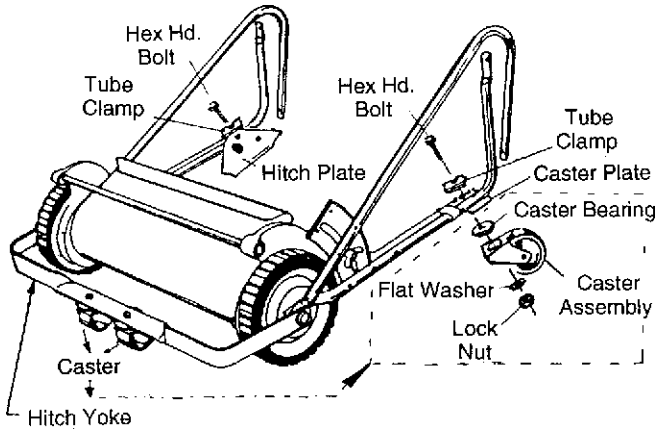

Remove the hitch plate from the right rear caster plate. You will need the tube clamp, nut and bolt that was used (to secure the hitch plate during shipment) for installing the right caster assembly. Install the casters using the parts sequence as shown above.

Install the hitch plate as shown using the nuts and bolts that were originally used to hold the casters in place during shipment.

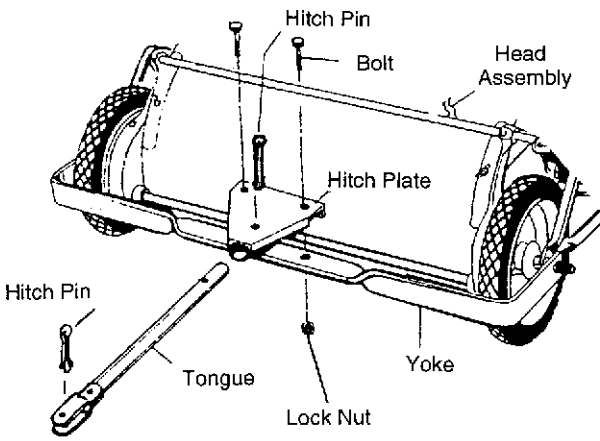

The tongue for the hitch plate is taped to the pivot rod of the basket assembly. The hitch pins are in each end of the tongue. Remove the hitch pins and install on the hitch plate shown in preceding picture.

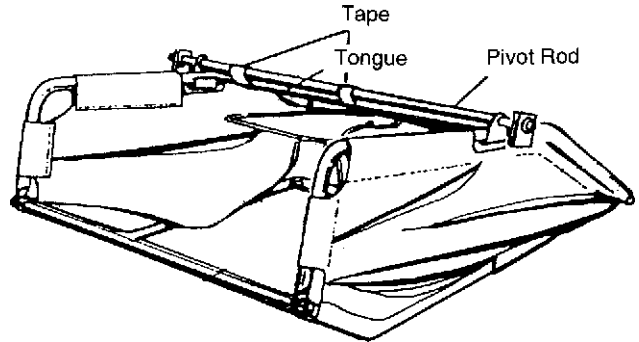

Lift the upper frame and assemble to the lower frame on both sides with the contour bolt, lockwasher and nut, by matching the holes near the end of each piece of tubing as shown bellow.

Assemble the upper frame to the brush adjusting bracket on both sides with the contour bolt, lockwasher and nut.

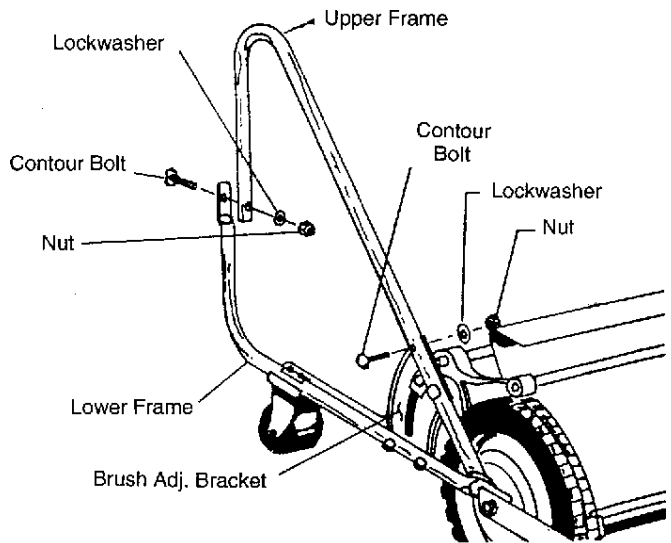

BASKET ASSEMBLY

1. Figure 1 below shows the basket assembly as removed from the carton.
2. Remove the rope clip from original shipping position and place in the center of the upper basket frame, as shown.
3. Raise the upper basket frame until the sides are taut (figure 2).
4. Place the basket under the rope clip. Push the rope clip down until the basket spring snaps into the notch on the under side of the basket frame.
5. Turn the rope clip until vertical (pointing down). The basket is now ready to be placed into the frame assembly.

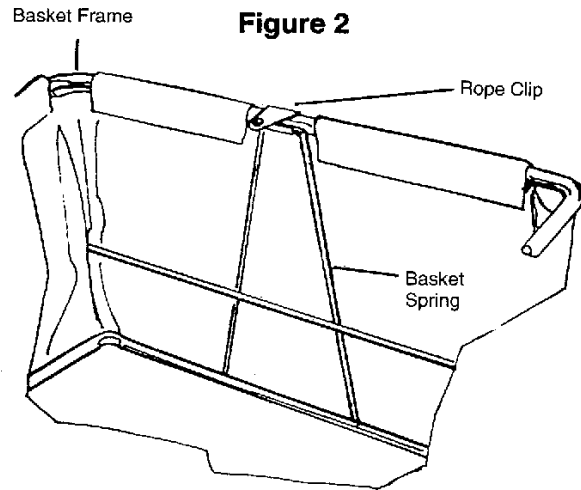
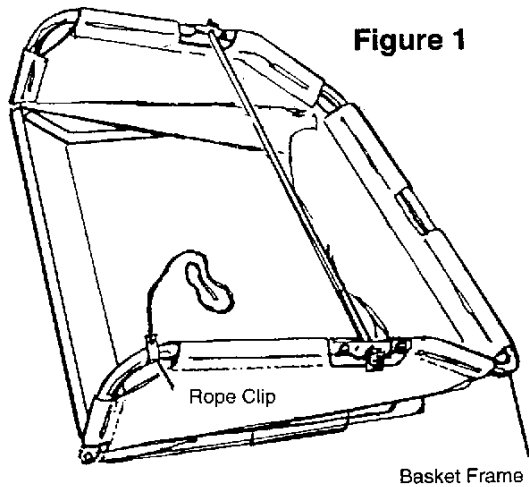

BASKET FRAME ASSEMBLY

1. Lower the basket into the frame assembly.
2. Hold the pivot latch on the basket in the up position while placing the pivot rod into the top slot of the pivot bracket. The pivot latch should straddle the pivot bracket as shown.
3. Move the pivot latch forward over the pivot bracket to lock into position.
4. Basket is now secured.

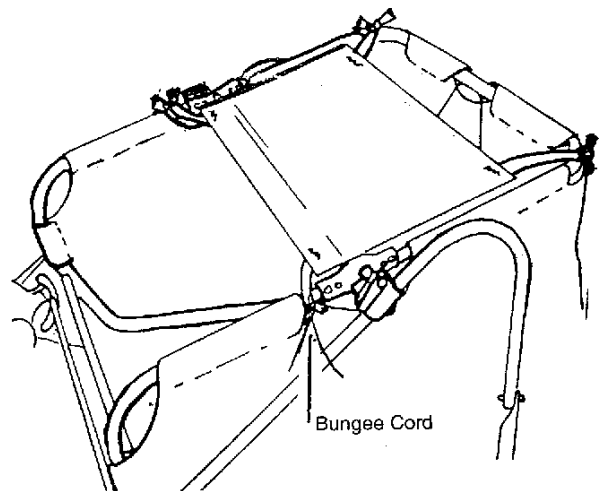
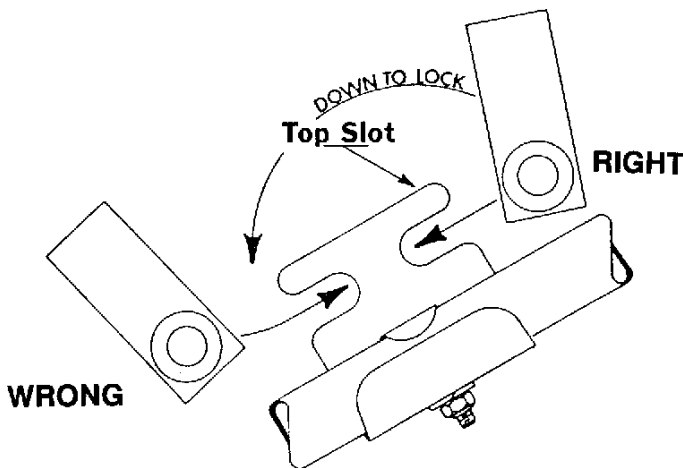

NOTE: The wind apron furnished with the unit is used to keep the sweepings in the basket on windy days or when sweeping at a high speed. The wind apron stretched across the basket and tied on the basket frame at the top corners as shown above it with supplied bungee cords.

OPERATING INSTRUCTIONS

TOWING THE SWEEPER

Trailing type sweeper should not be towed while mowing. The mowing speed is generally too slow for the sweeper to pick up grass, leaves or debris and throw them into the back of the basket.

OPERATING SPEED

Moving the sweeper forward rotates the brushes, propelling the leaves, clippings, etc. into the basket.

SWEEPING TIPS

- Use sweeper in early Spring to give your lawn a beautiful cleaning.
- Use your sweeper before mowing to pick up stones, sticks and other debris. This could save damage to the mower and prevent personal injury. Sweeping will also stand turf on end for a clean, even mowing.
- Use sweeper after mowing to remove turf clippings and give the lawn a blanket-like effect.
- Sweep often in Fall as leaves are dropping. Don't wait until all the leaves are all off trees.
- For best sweeping results keep lawn cut short. When sweeping turf clippings, do not overload basket. Turf clippings are heavy and overloading will put unnecessary stress on the basket.

DUMPING BASKET

The load is dumped from the basket by pulling the basket forward with the rope, causing the basket to pivot into a semi-inverted position. When the load is discharged, allow the rope and basket to return to their normal position.

BASKET CARE

The basket should always be emptied immediately after each time the sweeper is used, especially when the grass or leaves are wet or damp. Keeping the basket dry will lengthen its service life.

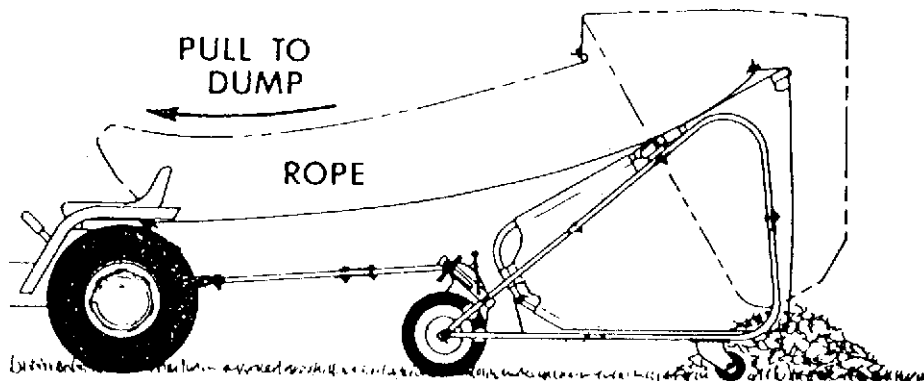

HOOD CARE

Wet grass clippings have a tendency to dry and adhere to the inner face of the hood; it is important to keep this face clean for a good sweeping action.

NOTE: If this unit is to be used on hard surfaces such as blacktop driveways or concrete walks, it is advisable to order caster roller 81-79-A to replace the supplied 76-58-A. Warranty on the 76-58-A caster roller is limited to lawn use only.

HOOD ADJUSTMENT

- The hood can be adjusted to change the deflection of the material being handled, by loosening the wing nuts in the lower corners of the hood and sliding the hood up or down.
- If sweeping at a high rate of speed the hood should be raised to deflect the material to the back of the basket. If set too low the material could be thrown over the back of the basket.
- If sweeping at a low speed the hood should be set until the material goes to the back of the basket.

LUBRICATION

Frequent lubrication of the sweeper will lengthen the service life of the machine.

Place a few drops of oil in the oil holes located in the hub of each wheel. Also, place a few drops of oil in the swivel bearings and axle of the casters every time the machine is used.

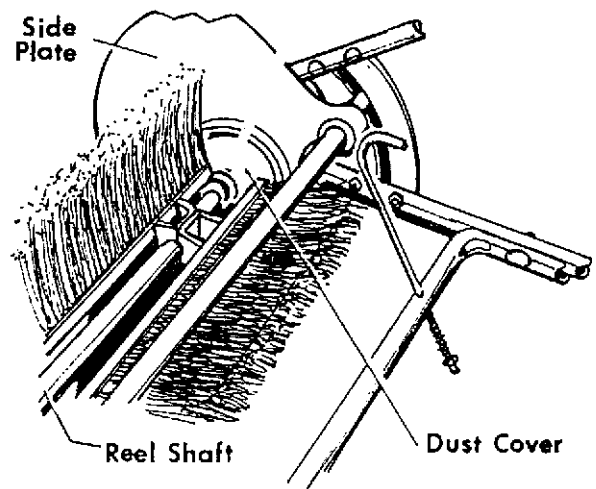
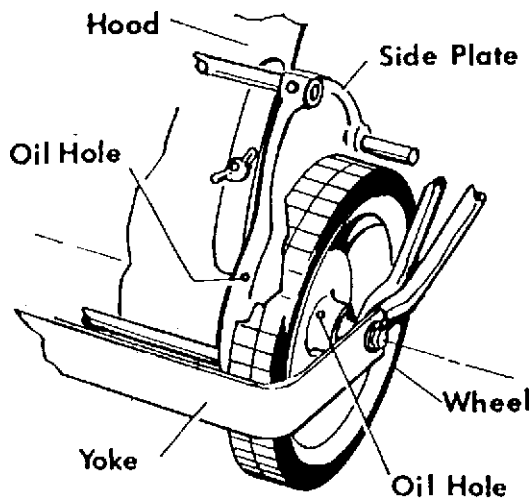

Before using the sweeper for the first time each season, remove both wheels and put a good grade of grease on the pinion gear and the gear of the wheel.

BRUSH CARE

BRUSH REMOVAL

Turn the sweeper upside down on the ground. Notice the stud has a collar against the brush bracket holding it against the reel shaft.

Remove the hex nuts and clamps from the stud on the end having the collar. Remove the brushes from the brush bracket slots (4 places). Now remove the hex nuts from the opposite ends of the studs. Do not remove the speed nuts or the studs will fall away from the reel shaft (4 places).

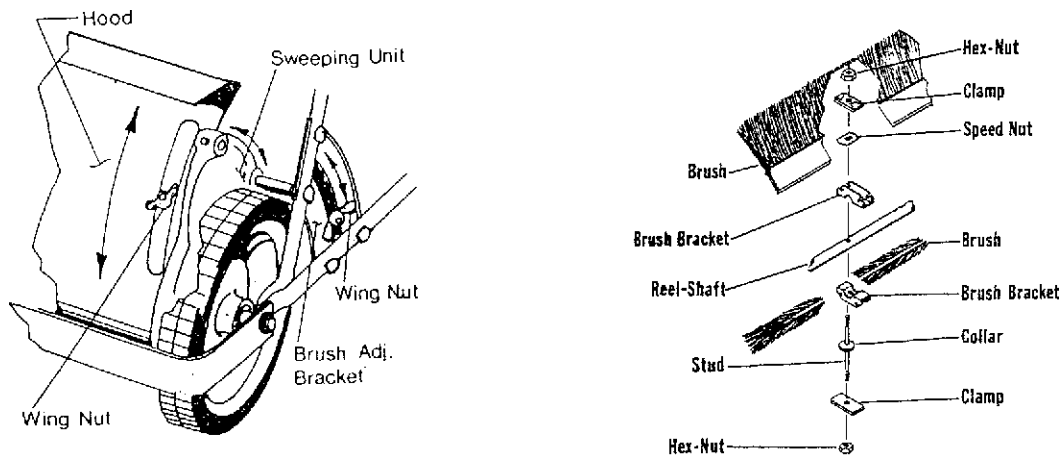

BRUSH REPLACEMENT

Turn the reel shaft to position in the brush strips in the slots on the brush bracket that are held on the stud and shaft by the speed nuts. Position the clamps and hex nuts, center the brush strips between the side plates, then tighten the hex nuts.

Turn the reel so that the brushes are on the bottom side. Now place the brush strips on the brush brackets on the top side. Position with clamps and hex nuts. Center the brush strips between the side plates, then tighten the hex nuts.

BRUSH HEIGHT ADJUSTMENT

- To raise brushes to extreme height, loosen the large wing nut, pull the sweeping unit forward as far as slots in brush will permit. To lower brushes to lowest position push sweeping unit backwards as far as slots in brush will permit. Secure wing nut when desired brush height is obtained.
- For grass clippings or leaves, adjust brushes to the highest position. After trial run on lawn, should the setting be too high, lower slightly and try again until correct setting is found. Brush life may be prolonged by adjusting so contact with ground is light. The lighter the contact, the longer the wear and ease in pulling.
- The most efficient operating height is when brushes just contact the top of the grass or make light contact with paved surfaces. When brushes are set too low, the sweeper will pull hard. This will lead to excessive brush wear and require premature brush replacement. Always have brushes in the raised position when transporting sweeper.

NOTE: If the brushes do not rotate and the wheels slide when the sweeper is being pulled, the brushes are set too low.

STORAGE

Clean the basket to remove clippings and debris

Wipe dirt and grease from the chassis. Repaint scratched areas and coat metal parts with oil to prevent rust.

Check sweeper parts for wear. Replace parts as necessary.

Remove the basket assembly from the sweeper, release the basket spring and fold as shown.

Remove the bolts, washer and nuts holding the upper and lower frames together and fold as shown.

Store sweeper in a dry area out of direct sunlight.

The illustration shows the head assembly flat against the wall with the tongue tied to an anchor screw or a nail in the wall. Tie a cord through the upper basket frame near the rope clip and hang it flat against the wall.

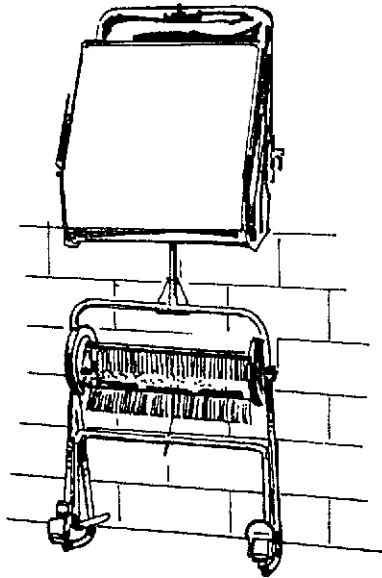

HOW TO RE-INSTALL PINIONS IN MANUAL OR TRAILING SWEEPERS

If for some reason you have found it necessary to remove the pinions, you should carefully follow these instructions. All parts must be clean before assembling.

1. To assist you, we suggest using a piece of wood doweling or plastic material 5/8" diameter, 2" long as shown. Each pinion is different as indicated by the part number and must be returned to the correct side of the shaft.

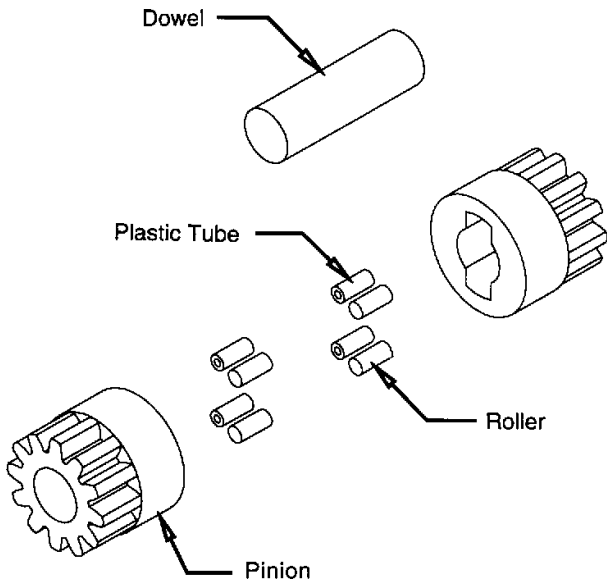

2. Insert the wooden dowel into the pinion.
3. Identify your pinion part number and insert the metal rollers. Place the plastic tubing in the cavity between the metal roller and the wall of the cavity. You may have to force the plastic tubing into this space but it is resilient and is suppose to fit tightly.

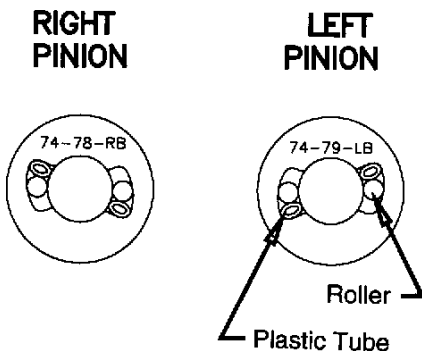

4. Pinion with part number 74-79 LB is to be replaced on the left side of the shaft. Part number 74-78 RB is for the right side. Line up the pinion (leaving the dowel in place) with the shaft as shown.

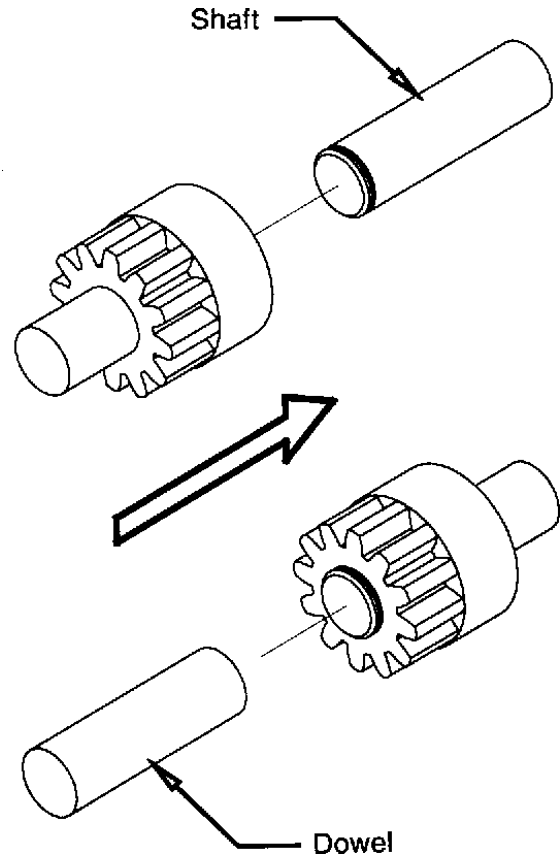

5. Push the pinion onto the shaft which will force the dowel to back out of the pinion. This will leave the rollers and plastic tubes in their proper position.
6. Apply a coating of grease on the outside of the wheel gear teeth. Do not grease inside pinions, this will cause pawl springs to be ineffective.

NOTE: The right and left sides are determined from the operators position.

SWEEPER UNIT ASSEMBLY

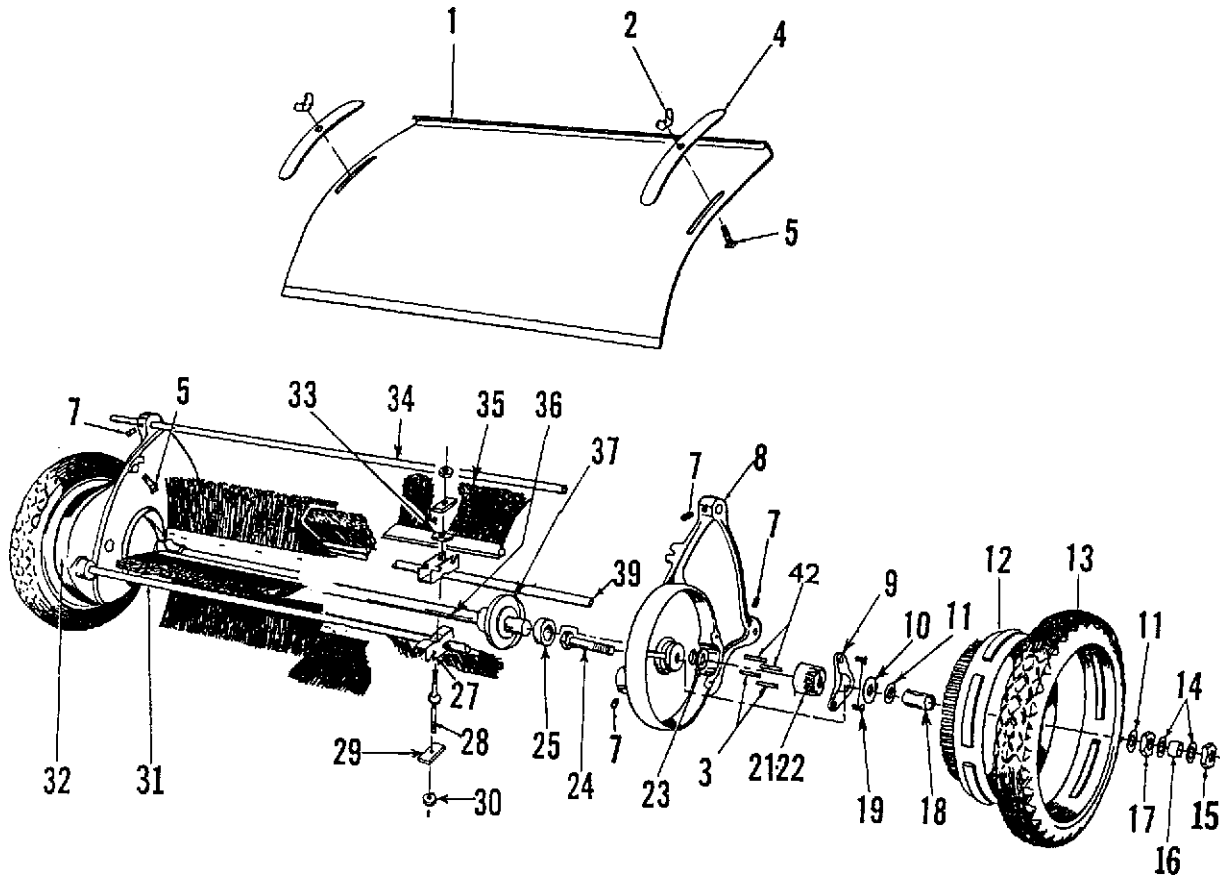

PARTS LIST

Item	Part No.	Qty.	Description	Item	Part No.	Qty.	Description
1	68-58PTD	1	Hood Parker, Burgundy	21A	SA-1580-B	1	Pinion Kit Incl: #3,21,22,42
2	351-516-20	2	Wing Nut	22	74-78-RB	1	Pinion Right
3	76-37-A	4	Pawl Spring	23	50-33-A	2	WSR-Special
4	49-11-A	2	Hood Clamp TE SU	24	53-35-A	2	Axle Bolt
5	713027	4	BLT-H/H 5/16-18 x 1, #5	25	68-60-A	2	Bearing
7	560C516-10	6	Square Head Set Screw	27	74-13-C	8	Bracket
8	76-339-LF	1	Side Plate LH	28	74-16PLT	4	Stud
9	80-01-B	2	Cover Pinion	29	69-04-A	8	Clamp Brush Strip
10	946-816-16	2	Fibre Washer	30	711425	8	Nut-Flanged Wizz 1/4-20
11	58-05-A	4	Washer Special	31	68-33PLT	1	Tie Rod Zinc Plated
12	58-14PTD	2	Wheel Hub	32	76-338-RF	1	Side Plate RH
13	75-88-C	2	Tire Only	33	75-89-A	4	Speed Nut
13A	SA-609-C	1	Tire Assy. Includes 12 & 13	34	68-34PLT	1	Tie Rod
14	711509	4	WSR-Flat 1/2 ST PL	35	1200-17-B	8	Brush Assembly TE
16	68-44-A	2	Spacer Axle	35A	BK-11	1	Brush Kit, TE & SU
17	326-816	2	Hex Nut	36	79-103-B	1	Reel Shaft
17A	368-816	2	Half Nut Nyloc 1/2-20	37	74-166PLT	2	Dust Cover Zinc Plated
18	58-06-A	2	Sleeve	39	76-341PLT	1	Adj. Tube Zinc Plated
19	506-416-10	4	SCR-FH 1/4-20 x 5/8	42	74-80-A	4	Pawl
21	74-79-LB	1	Pinion Left				

FRAME ASSEMBLY

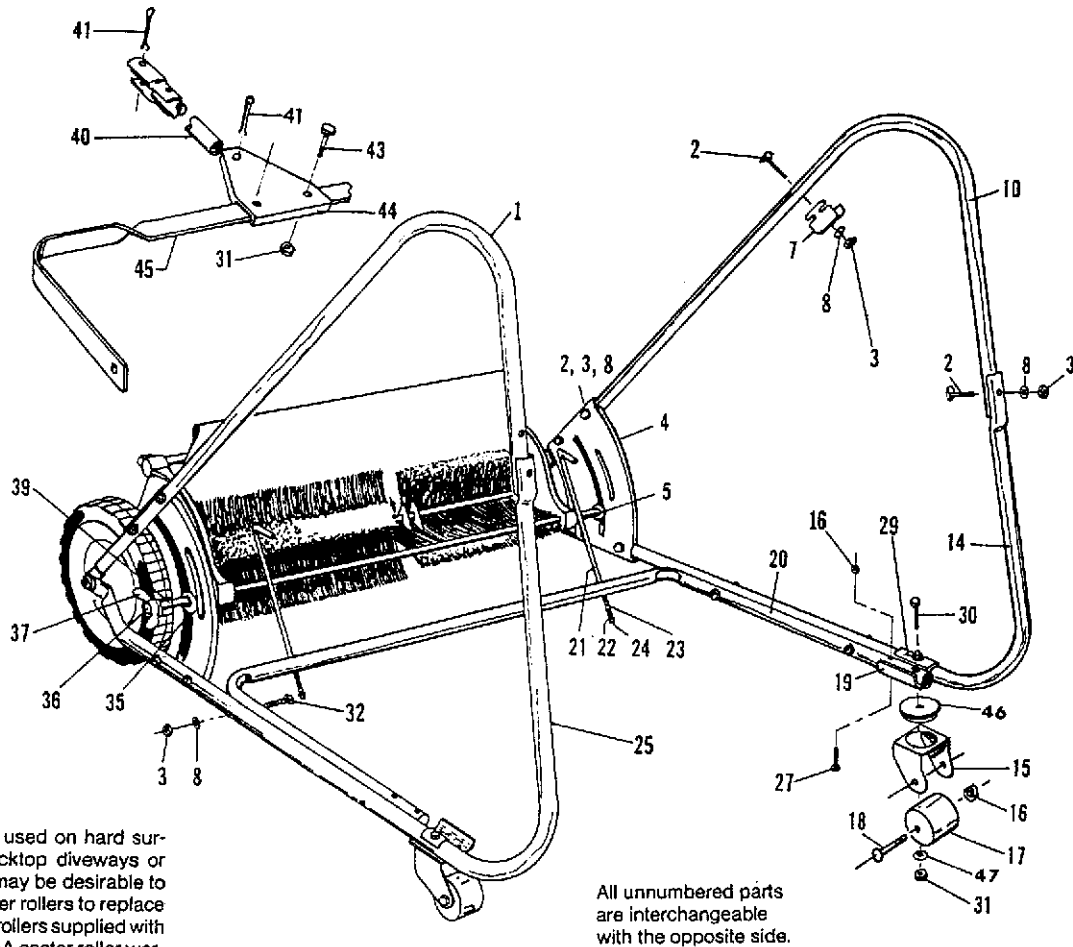

Note:

If this unit is to be used on hard surfaces such as blacktop driveways or concrete walks, it may be desirable to order 81-79-A caster rollers to replace the 76-58-A caster rollers supplied with the unit. The 76-58-A caster roller warranty is limited to lawn use only.

All unnumbered parts are interchangeable with the opposite side.

PARTS LIST

Item	Part No.	Qty.	Description	Item	Part No.	Qty.	Description
1	76-283-LC	1	Frame Upper LH TE	23	76-271-A	2	Spring
2	69-416-20	12	BLT Cont. HD 1/4-20 x 1.25	24	75-89-A	2	Speed Nut
3	711316	16	Nut-Hex 1/4-20 ST PL	25	76-281-LC	1	Lower Support Left Hand
4	76-342-C	2	Plate Ad. TE	27	713004	4	BLT-HH 1/4-20 x 1 1/4 #5
5	711508	2	WSR-Flat .44 x 1.00 x .08	29	59-77-A	2	Clamp
7	76-240-A	2	Bracket Pivot	30	713031	2	BLT-HH 5/16-18 x 2 #5
8	711544	16	WSR-Helical 1/4	31	711374	4	Nut-Nyloc 5/16-18
10	76-284-RC	1	Frame Upper RH TE	32	69-416-28	4	BLT Cont. Hd 1/4-20 x .1.75
14	76-280-RC	1	Lower Support Frame RH	35	711506	3	WSR-Flat 5/16 ST PL
15	76-136-B	2	Caster Fork	36	69-111-A	1	Bolt Adj. TE
15A	SA-578-B	2	Caster Assembly	37	73-71-A	1	Wing Nut
16	711373	6	Nut-Nloc 1/4-20	39	55-160-A	1	Spacer Adj. BLT
17	76-58-A	2	Roller	40	75-32-B	1	Tongue Weldment
18	76-202-A	2	Axle 3/8 D x 2.06	41	81-14-A	2	Clinch Pin
19	76-81-B	2	Plate Caster	44	75-40-B	1	Hitch Plate Weldment
20	76-272-B	1	Frame Support TE	45	75-134-B	1	Yoke
21	76-255-A	2	Basket Stop	46	78-130-A	2	Bearing
22	711505	2	WSR-Flat 1/4	47	82-138-B-1	2	Special Washer

BASKET ASSEMBLY

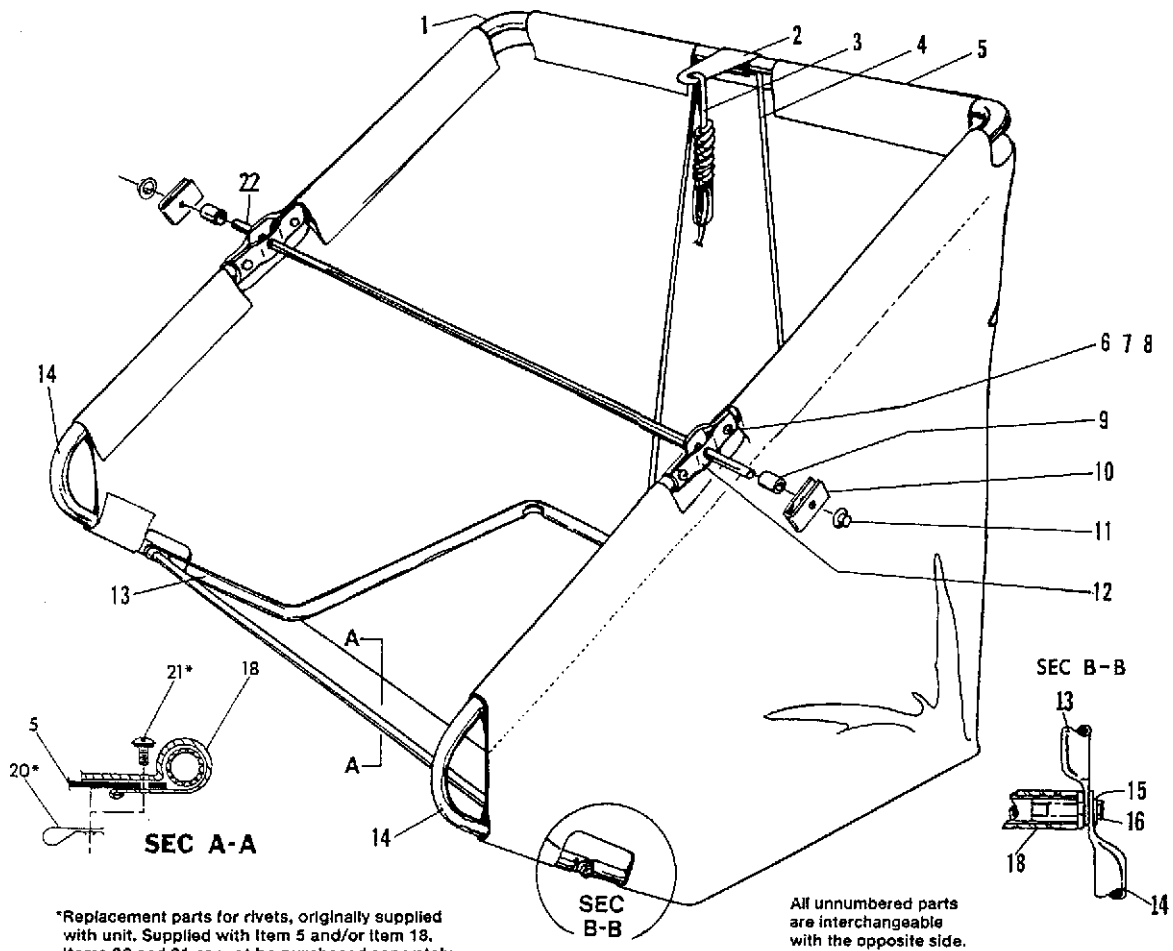

*Replacement parts for rivets, originally supplied with unit. Supplied with Item 5 and/or Item 18. Items 20 and 21 cannot be purchased separately.

All unnumbered parts are interchangeable with the opposite side.

PARTS LIST

Item	Part No.	Qty.	Description	Item	Part No.	Qty.	Description
1	76-326-B	1	Frame Basket Rear	11	76-254-A	2	End Cap
2	76-252-A	1	Rope Clip	12	79-112-B	4	Pivot Bearing
2A	SA-969-A	1	Rope and Clip Assembly	13	83-82-C	1	Frame Basket Lower
3	60-09-A	1	Rope Cut Assembly HS TE	14	76-285-B	2	Frame Basket Front TE
4	83-33-B	1	Basket Spring	15	711545	2	WSR-Helical 5/16
5	SA-1211-C	1	Basket Replacement	16	713027	2	BLT-HH 5/16-18 x 1 #5
6	69-416-24	2	BLT Cont. HD. 1/4-20 x 1.5	18	83-160-B	1	Clamp
7	711554	4	Internal Lockwasher 1/4	20	66-96-A	5	U-Type Speed Nut
8	711316	4	Nut-Hex 1/4-20 ST PL	21	526-1024-8	5	Truss Head Screw
9	73-414-A	2	Spacer Back Cover	22	76-275-A	1	Rod Pivot
10	76-242-A	2	Latch Pivot	23	SA-1709	1	Wind Apron TE

LIMITED WARRANTY

The Parker Sweeper Company warrants to the original purchaser/user that this product is free from defects in workmanship and materials under normal use and service for a period of two years from date of purchase. In addition, Parker Sweeper Company will, at its option, honor labor warranty claims for the first 12 months from date of sale, provided such claims are submitted through and approved by factory authorized repair stations. Parker Sweeper Company will, at its option, repair or replace without charge, except for transportation costs, parts that fail under normal use and service when operated and maintained in accordance with the applicable operation and instruction manuals.

This warranty does not apply to normal wear, or to items whose life is dependent on their use and care, such as belts, cords, switches, hoses, rubber parts, electrical motor components or adjustments. Parts not manufactured by Parker Sweeper Company such as engines, batteries, battery chargers, hydraulic pumps, and tires are covered by and subject to the warranties and/or guarantees of their manufacturers. Please contact Parker Sweeper Company for procedures in warranty claims against these manufacturers.

Special warning to purchaser — Use of replacement filters and/or prefilters not manufactured by Parker Sweeper Company or its designated licensees, will void all warranties expressed or implied.

A potential health hazard exists without exact original equipment replacement.

All warranted items become the sole property of Parker Sweeper Company or its original manufacturer, whichever the case may be.

Parker Sweeper Company disclaims any implied warranty, including the warranty of merchantability and the warranty of fitness for a particular purpose. Parker Sweeper Company assumes no responsibility for any special, incidental or consequential damages.

This limited warranty is applicable only in the U.S.A. and Canada, and is extended only to the original user/purchaser of this product. Customers outside the U.S.A. and Canada should contact their local distributor for export warranty policies. Parker Sweeper Company is not responsible for costs or repairs performed by persons other than those specifically authorized by Parker Sweeper Company. This warranty does not apply to damage from transportation, alterations by unauthorized persons, misuse or abuse of the equipment, use of non-compatible chemicals, or damage to property, or loss of income due to malfunctions of the product.

If a difficulty develops with this machine, you should contact the dealer from whom it was purchased.

This warranty gives you specific legal rights, and you may have other rights which vary from state to state. Some states do not allow the exclusion or limitation of special, incidental or consequential damages, or limitations on how long an implied warranty lasts, so the above exclusions and limitations may not apply to you.



A Minuteman International Company

World Headquarters

Minuteman International, Inc.
111 South Rohlwing Road
Addison, Illinois 60101

Minuteman Canada, Inc.
2210 Drew Road
Mississauga, Ontario
L5S 1B1

(630) 627-6900
FAX (630) 627-1130

(905) 673-3222
FAX (905) 673-5161

988385
Printed in U.S.A.