



Electronic Service Manuals

This electronic document is provided as a service to our customers. We do not create the contents of the information contained in this document. Should you have detailed questions pertaining to the information contained in this document, you may contact Michco, or the manufacturer which provided the original information in this electronic deliverable. Michco's only part in this electronic deliverable was the electronic assembly process. By providing this manual on line we are not guaranteeing parts availability.

You may contact Michco through the following methods:

Phone (517) 484-9312 or (800) 331-3339

2011 N. High St. -- Lansing, Michigan -- 48906

Fax: (517) 484-9836

Email: CustServe@Michco.com

Web site: www.Michco.Com

Parts Web site: www.FloorMachineParts.Com

Order Parts on Line at:

www.FloorMachineParts.Com

Directly to Parts & Service:

By Email: **Shop@Michco.com**

By Fax: (517) 702-2041

By Voice: Use numbers above.

Serving the Cleaning Industry Since 1922

Notice: All copyrighted material remains property of original owners, all trademarks are property of respective owners. Manuals are subject to Manufacturer's reproduction limitations. Originals or reproductions were provided by manufacturers through a request. We make no warranty as to the correctness of information provided in this document and you assume all risk. By placing these manuals on line we are not declaring our corporation to be an manufacturer authorized dealer or provider, please check our web site for authorized manufacturers we represent.

OWNER'S GUIDE



TE-9036 TRAILETTE

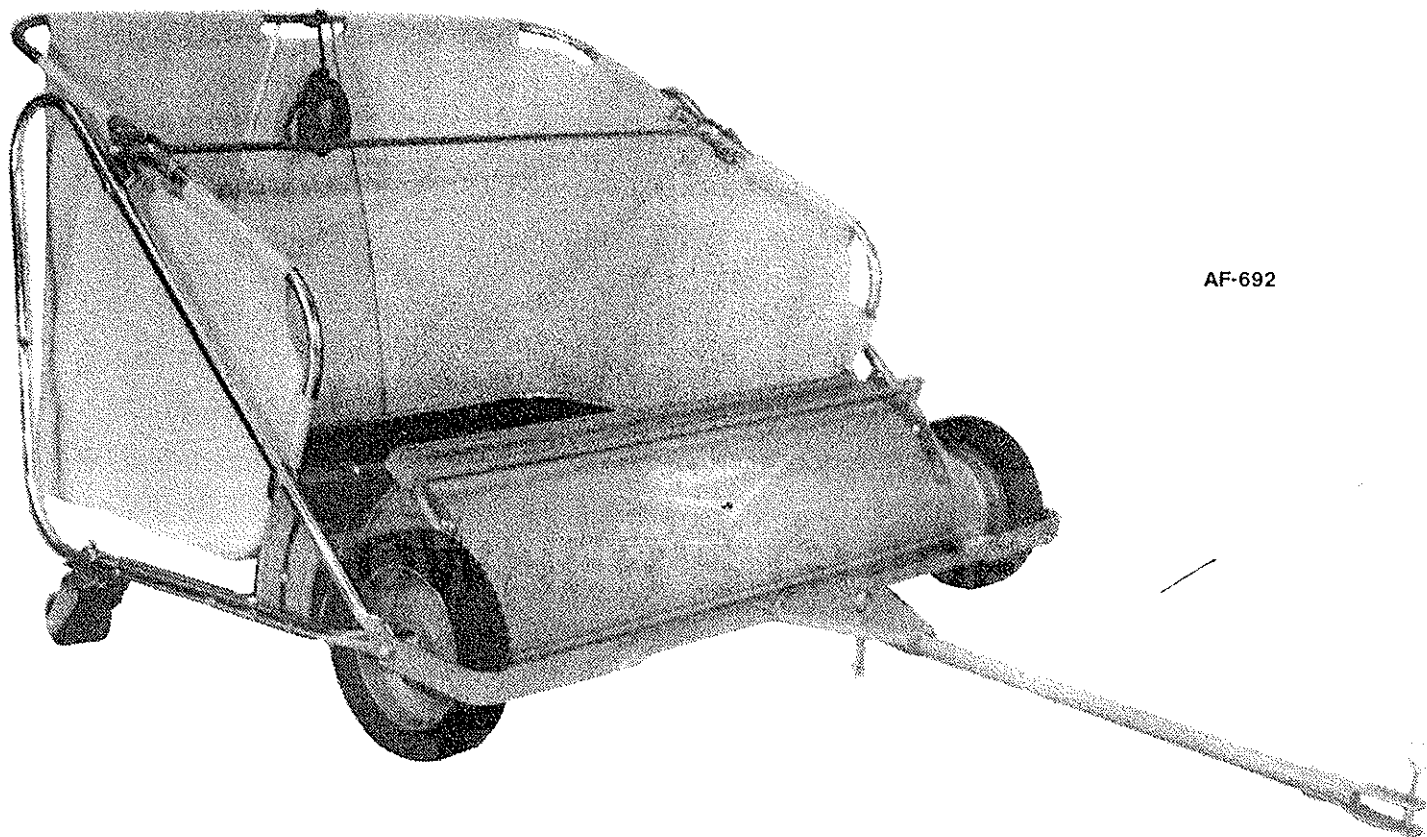

AF-692

**BE SAFE. PROTECT YOUR FAMILY, YOUR FRIENDS, YOURSELF.
OBSERVE ALL SAFETY INSTRUCTIONS.**

**READ THESE INSTRUCTIONS BEFORE SETTING UP
AND OPERATING MACHINE**

PARKER SWEEPER COMPANY

Box 1728

Springfield, Ohio 45501-1728

Plate No. 1486

90-05-A

ASSEMBLY INSTRUCTIONS

The picture below shows the Basket Assembly as removed from the Carton.

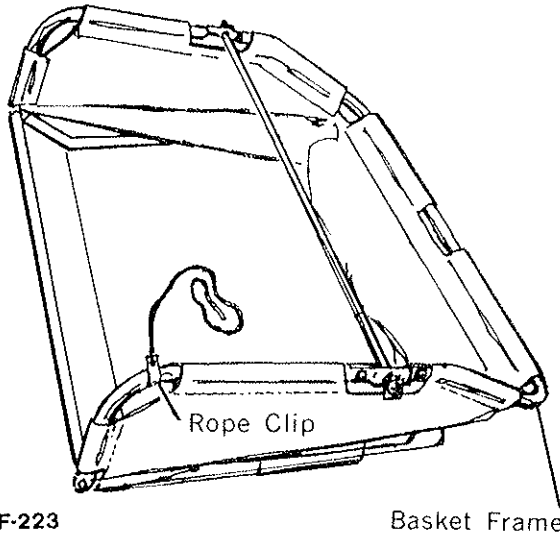

Place the Basket Spring under the Rope Clip as shown.

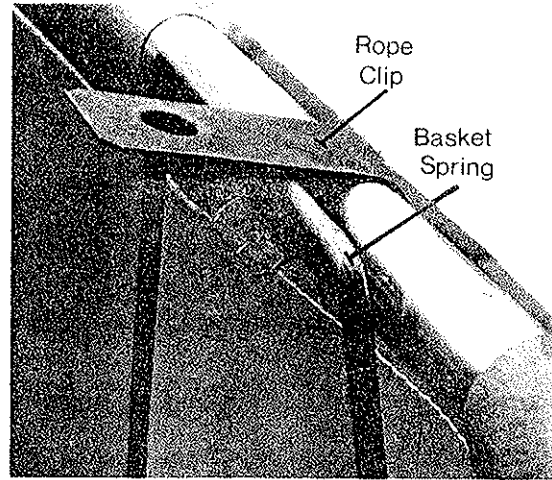

Push the Rope Clip down until the Basket Spring snaps into the notch on the under side of the Basket Frame as shown.

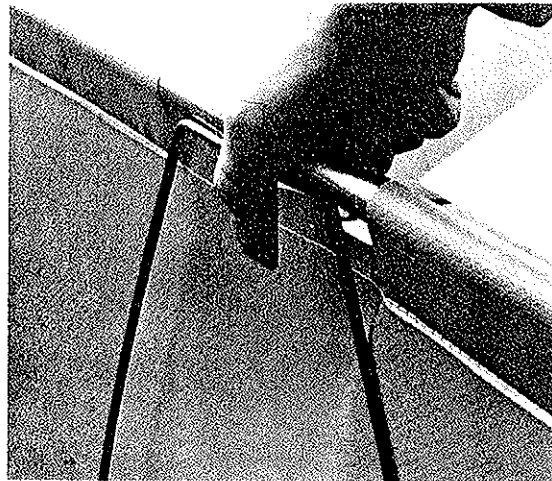

Remove rope clip from position shown above, and place in the center of the Upper Basket Frame, as shown below. Raise the Upper Basket Frame until the sides are taut, as shown below.

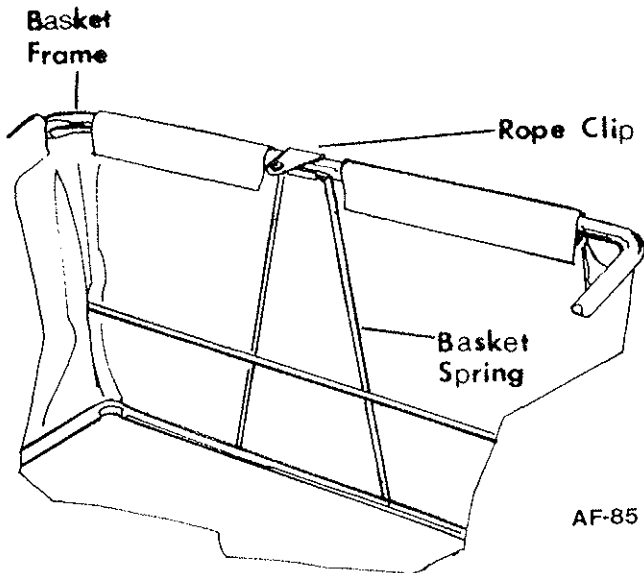

Now turn the Rope Clip to the position as shown. The Basket is now ready to place into the Frame Assembly.

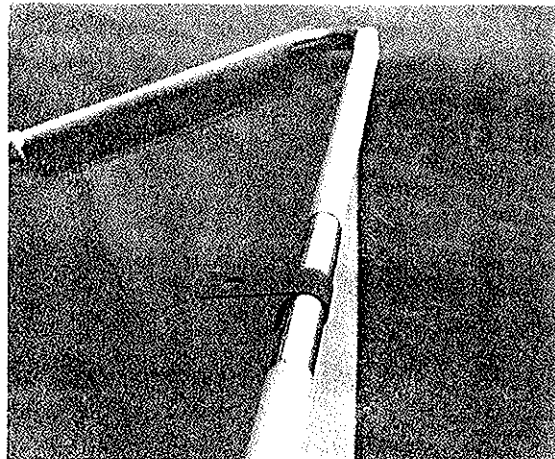

ASSEMBLY INSTRUCTIONS

OBSERVE SAFETY RULES AT ALL TIMES. DON'T TAKE CHANCES!

Attaching Basket

1. Now add Basket to Head and Frame Assembly.
2. Hold Pivot Latch on Basket in the up position while placing the Pivot Rod into the **TOP SLOT** of the Pivot Bracket.
3. The Pivot Latch should straddle the Pivot Bracket as shown.
4. Move the Pivot Latch forward over Pivot Bracket to lock into position.
5. Basket is now secured.

The Wind Apron is furnished with the unit. It is used to keep the sweepings in the basket on windy days or when sweeping at a high speed. The Wind Apron is stretched across the basket and tied on the basket frame at the top corners and middle below the pivot bracket, as shown below.

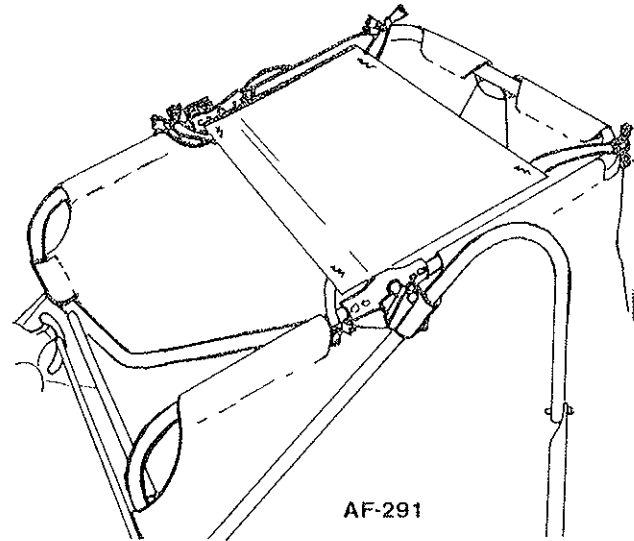
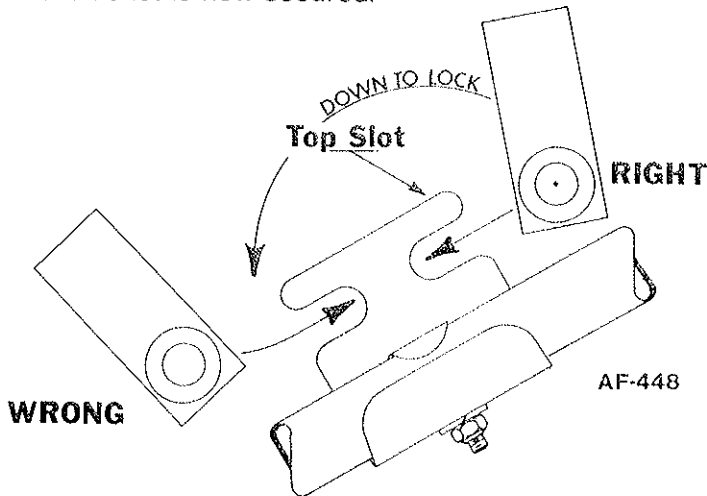

OPERATING INSTRUCTIONS

Brush Height Adjustment

The most efficient operating height is when the brushes just make contact with the top of the grass or make light contact with paved surfaces. When the brushes are set too low, the sweeper will pull hard. This will lead to pulling difficulties, excessive brush wear and premature mechanical failure. Always have brushes in the raised position when transporting sweeper.

To Adjust Brushes

Loosen the large wing nut. To raise brushes to extreme height, pull Sweeping Unit forward as far as slots in the Brush Adjustment Brackets will permit. To lower brushes to lowest position, push Sweeping Unit backwards as far as slots will permit. Secure wing nut when the desired brush adjustment is obtained.

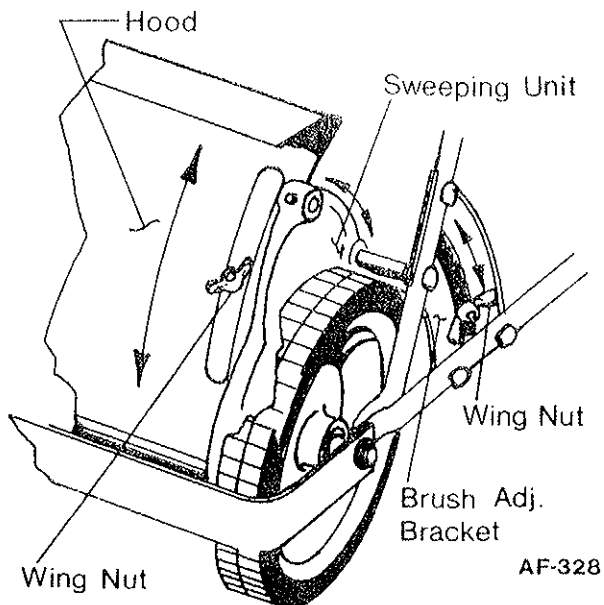

The Hood is a part of the sweeping unit, but can also be adjusted independently by loosening the two wing nuts on each side. For grass clippings or leaves, adjust the hood and brushes to highest position. After trial run on lawn, should the settings be too high, lower slightly and try again until correct setting is found. Brush life may be prolonged by adjusting so contact with the ground is light. The lighter the contact, the longer the wear and easier to pull.

Note: If the brushes do not rotate and the wheels slide when the Sweeper is being pulled, the brushes are set too low.

If the brushes and the wheels rotate when the Sweeper is being pulled, but pulls hard, the Hood Extension is set too low.

OPERATING INSTRUCTIONS

TOWING THE SWEEPER

Trailing type sweepers should not be towed while mowing, as the mowing speed is generally too slow for the sweeper to pick up grass, leaves, or debris and throw them into the back of the basket.

SWEEPING TIPS

Use sweeper in early spring to give your lawn a healthful cleaning.

Use your sweeper before mowing to pick up stones, sticks and other debris. This could save damage to mower and prevent personal injury. Sweeping will also stand turf on end for a clean, even mowing.

Use sweeper after mowing to remove turf clippings and give the lawn a blanket-like effect.

Sweep often in fall as leaves are dropping. Do not wait until leaves are all off trees.

For best sweeping results keep lawn cut short. When sweeping turf clippings do not overload Basket. Turf clippings are heavy and over-loading will put unnecessary stress on the Basket.

CARE AND BRUSH REMOVAL

Turn the Sweeper upside down on the ground. Notice the stud has a collar against the brush bracket holding it against the reel shaft.

AF-185 - Remove the hex nuts and clamps from the stud on the end having the collar. Remove the brushes from the brush bracket slots (4 places). Now remove the hex nuts and clamps from the opposite end of the studs. Do not remove the speed nuts or the studs will fall away from the reel shaft (4 places).

BRUSH REPLACEMENT

AF-185 - Turn the reel shaft so you can position the brush strips in the slots on the brush bracket that are being held on the stud and shaft by the speed nut. Position the clamps and hex nuts, center the brush strips between the side plates, then tighten brush strips between the side plates, then tighten the hex nuts.

Turn the reel shaft so the brushes are on the bottom side. Now place the brush strips in the slots on the brush brackets on the top side. Position with clamps and hex nuts. Center the brush strips between the side plates, then tighten the hex nuts.

HOOD CARE

Wet grass clippings have a tendency to dry and adhere to the inner face of the hood; it is important to keep this face clean for good sweeping action.

NOTE: If this unit is to be used on hard surfaces such as blacktop driveways or concrete walks, it may be desirable to order 81-79-A caster rollers to replace the 76-58-A caster rollers supplied with the unit. The 76-58-A caster roller warranty is limited to lawn use only.

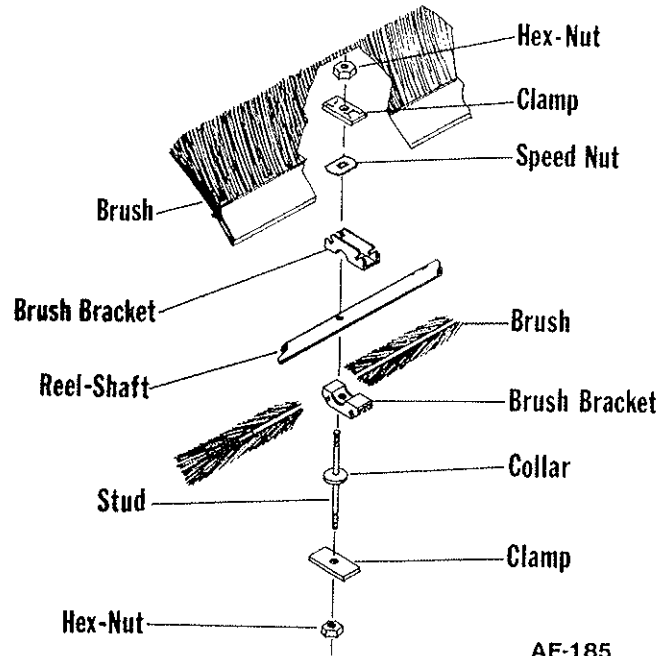

LUBRICATION

Frequent lubrication of the Sweeper will lengthen the service life.

AF-96 - Place a few drops of oil in the oil holes located in the hub of each wheel.

Also, place a few drops of oil in the swivel bearings and axle of the casters every time the machine is used.

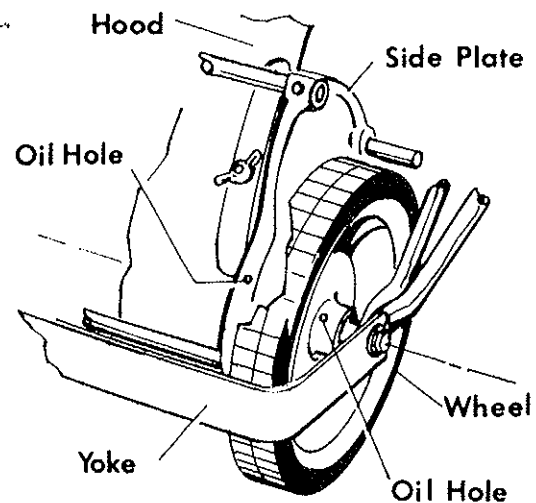

LUBRICATION

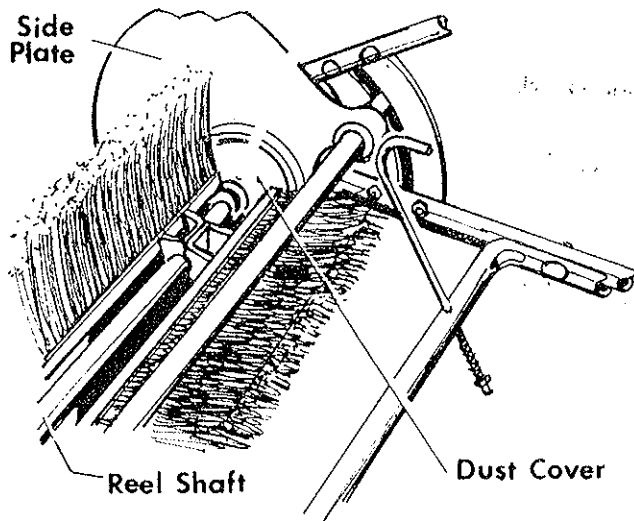

AF-95

Before using the Sweeper the first time each season, remove both wheels and put a good grade of grease on the pinion gear and the gear of the wheel.

OPERATING SPEED

Moving the Sweeper forward rotates the brushes, propelling the leaves, clippings, etc., into the basket.

Select a forward travel speed that provides efficient sweeping without throwing debris over the back of the basket.

CAUTION: The basket has been designed for holding a large capacity of dry grass clippings. When clippings are wet or fresh cut, caution should be exercised as the amount picked up. The basket could be overloaded and make dumping difficult.

DANGER: Do not hold dumping rope in hand while towing. Secure loose end to tractor behind operator.

CAUTION! This sweeper is not designed to haul people, animals or equipment. Severe damage to the sweeper and possible injury to people or animals may result if this warning is ignored.

DUMPING BASKET

The load is dumped from the basket by pulling the basket forward with the rope, causing the basket to pivot into a semi-inverted position. When load is discharged, allow rope and basket to return to their normal position.

BASKET CARE

The basket should always be emptied immediately after each time the Sweeper is used, especially if the grass or leaves are wet or damp. Keeping the basket dry will lengthen its service life.

STORAGE

Clean basket to remove clippings and debris.

Wipe dirt and grease from the chassis. Repaint scratched areas and coat metal parts with oil to prevent rust.

Store Sweeper in a dry area out of direct sunlight.

Check sweeper parts for wear. Replace parts as necessary.

Remove the basket assembly from the sweeper, release the basket spring and fold as shown below.

Remove the bolts, washers and nuts holding the upper and lower frames together, and fold as shown.

The drawing below shows the head assembly flat against a wall with the tongue tied to an anchor screw or nail in the wall. Tie a cord through the upper basket frame near the rope clip and hang it flat against the wall from an anchor screw or nail.

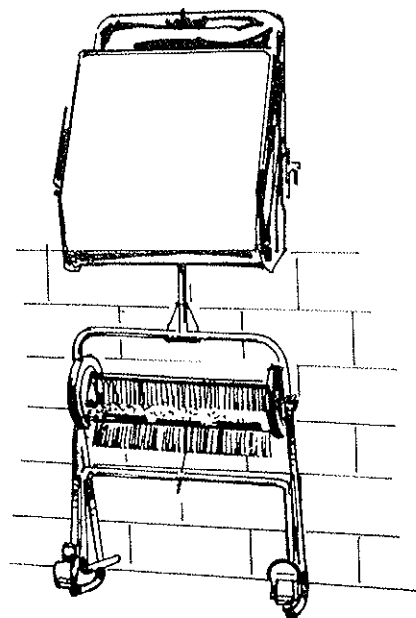

AF-97

HOW TO RE-INSTALL PINIONS IN MANUAL OR TRAILING SWEEPERS

If for some reason you have found it necessary to remove the pinions, you should carefully follow these instructions. All parts must be clean before assembling.

- (1) To assist you, we suggest using a piece of wood doweling or plastic material $\frac{5}{8}$ " diameter, 2" long as shown. Each pinion is different as indicated by the part number and must be returned to the correct side of the shaft.

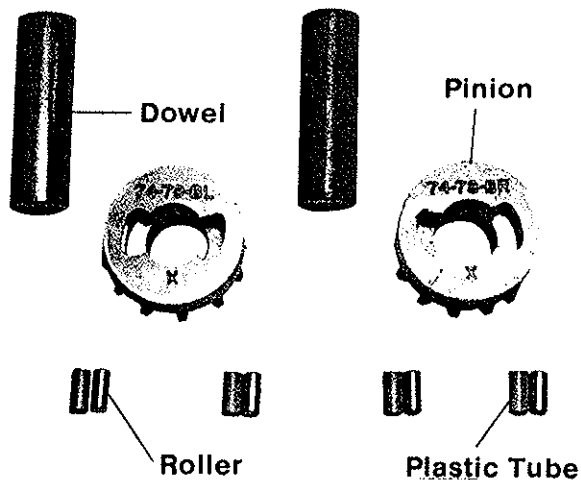

- (2) Insert the wooden dowel into the pinion.

- (3) Identify your pinion part number and insert the metal rollers. Place the plastic tubing in the cavity between the metal roller and the wall of the cavity. You may have to force the plastic tubing into this space but it is resilient and is supposed to fit tightly.

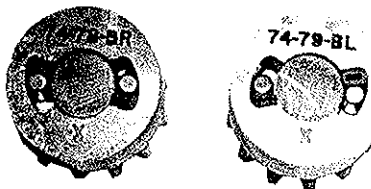

NOTE! The right and left side are determined from the operators position.

- (4) Pinion with part number **74-79 BL** is to be replaced on the **left side** of the shaft. Part number **74-78 BR** is for the **right side**. Line up the pinion (leaving the dowel in place) with the shaft as shown.

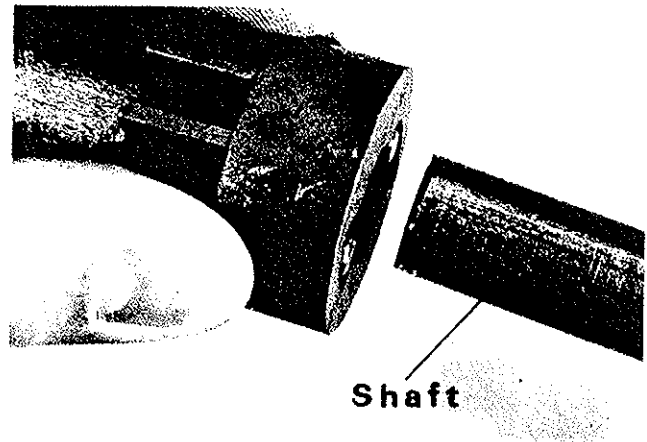

- (5) Push the pinion onto the shaft which will force the dowel to back out of the pinion. This will leave the rollers and plastic tubes in their proper position.

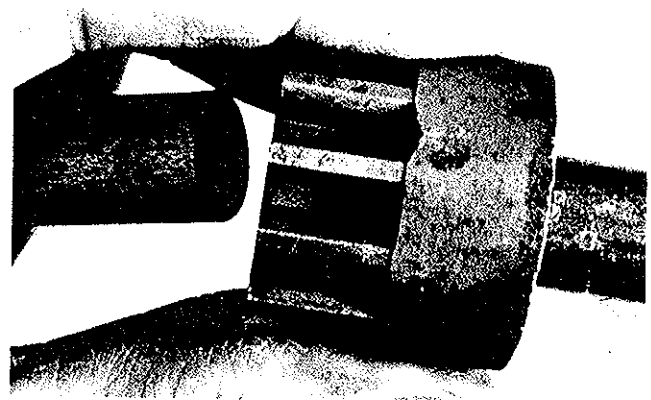

- Do Not*
(6) Apply a coating of grease on the outside of the wheel gear teeth. Do not grease inside pinion as this will cause pawl springs to be ineffective.

SWEEPER UNIT ASSEMBLY

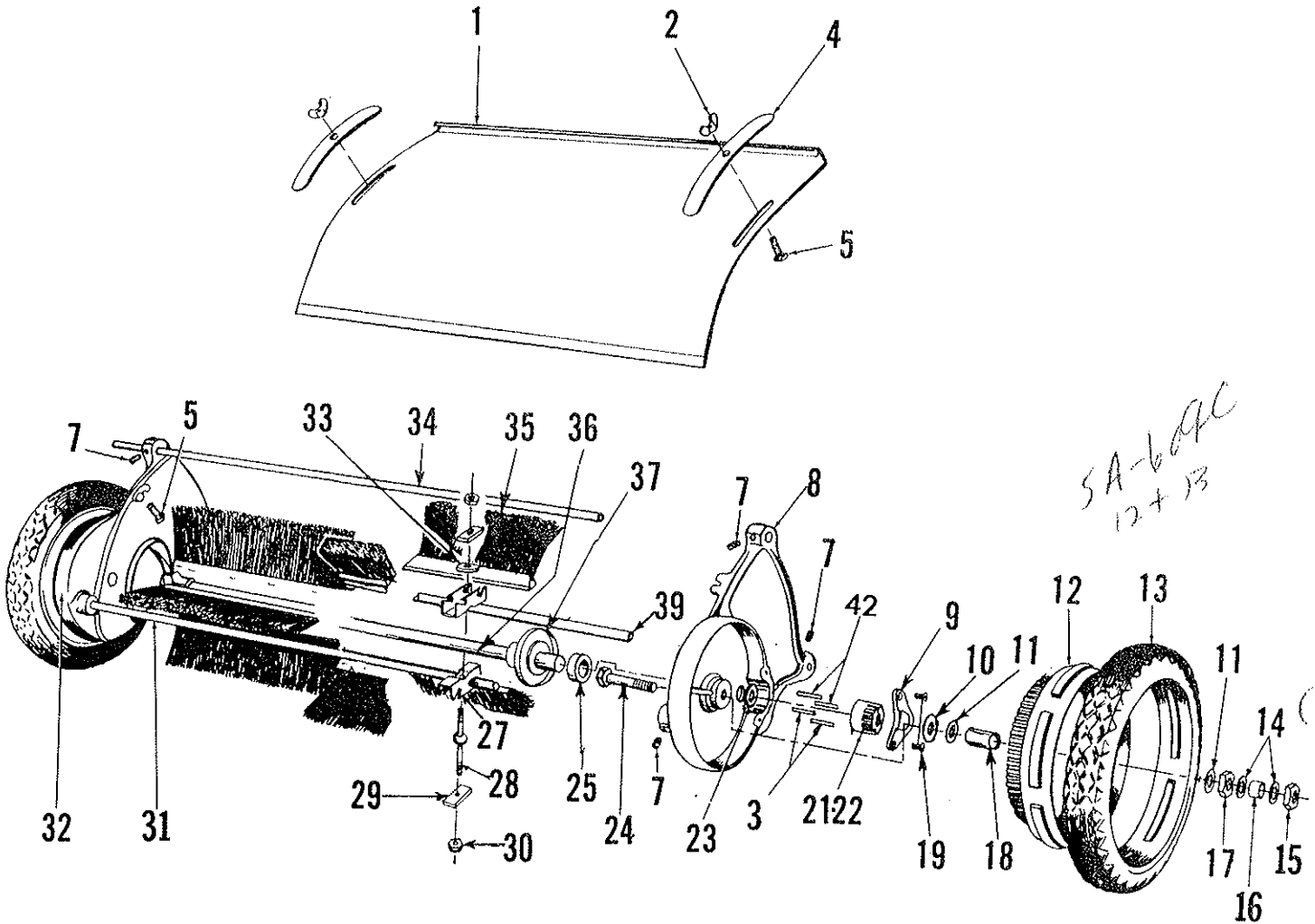

PARTS LIST

Ref. No.	Part No.	Qty. Per Unit	Description	Ref. No.	Part No.	Qty. Per Unit	Description
1	90-03-D	1	Hood & Silkscreen	21	74-79-LC *	1	Left Hand Pinion
2	351-516-20	2	Wing Nut 5/16-18	22	74-78-RC *	1	Right Hand Pinion
3	76-37-A *	4	Pawl Spring	23	50-33-A	2	Special Washer
4	49-11-A	2	Hood Clamp	24	53-35-A	2	Axle
5	65-516-12	2	Bolt, Hex Hd. 5/16-18 x 3/4	25	68-60-A	2	Ball Bearing
7	560-C-516-10	6	Set Screw 5/16-18 x 5/8	27	74-13-C	8	Brush Bracket
8	76-339-D	1	Left Hand Side Plate	28	74-16-A	4	Brush Stud
9	80-01-B	2	Pinion Cover	29	69-04-A	8	Brush Clamp
10	946-816-16	2	Fiber Washer	30	362-416	8	Hex. Lock Nut 14-20
11	58-05-A	4	Special Washer	31	68-33-A	1	Front Tie Rod
12	58-14-D-1	2	Wheel	32	76-338-D	1	Right Hand Side Plate
13	75-88-C	2	Tire	33	75-89-A	4	Retainer
14	945-816	4	Flatwasher, Plain 1/2	34	68-34-A	1	Top Tie Rod
15	368-816	2	Nut, Hex Lock (Thin) 1/2-20	35	1200-17-C	8	Brush Strip
16	68-44-A	2	Axle Spacer	36	79-103-B	1	Reel Shaft
17	326-816	2	Nut, Plain Hex (Thick) 1/2-20	37	74-166-B	2	Dust Cover
18	58-06-A	2	Sleeve	39	76-341-A	1	Adjusting Tube
19	506-416-10	4	Screw, Flat Hd. 1/4-20 x 3/8 Self-Tapping	42	74-80-A *	4	Pawl

* SA-1580-B PINION KIT - CONTAINS #'S 3, 21, 22 & 42

FRAME ASSEMBLY

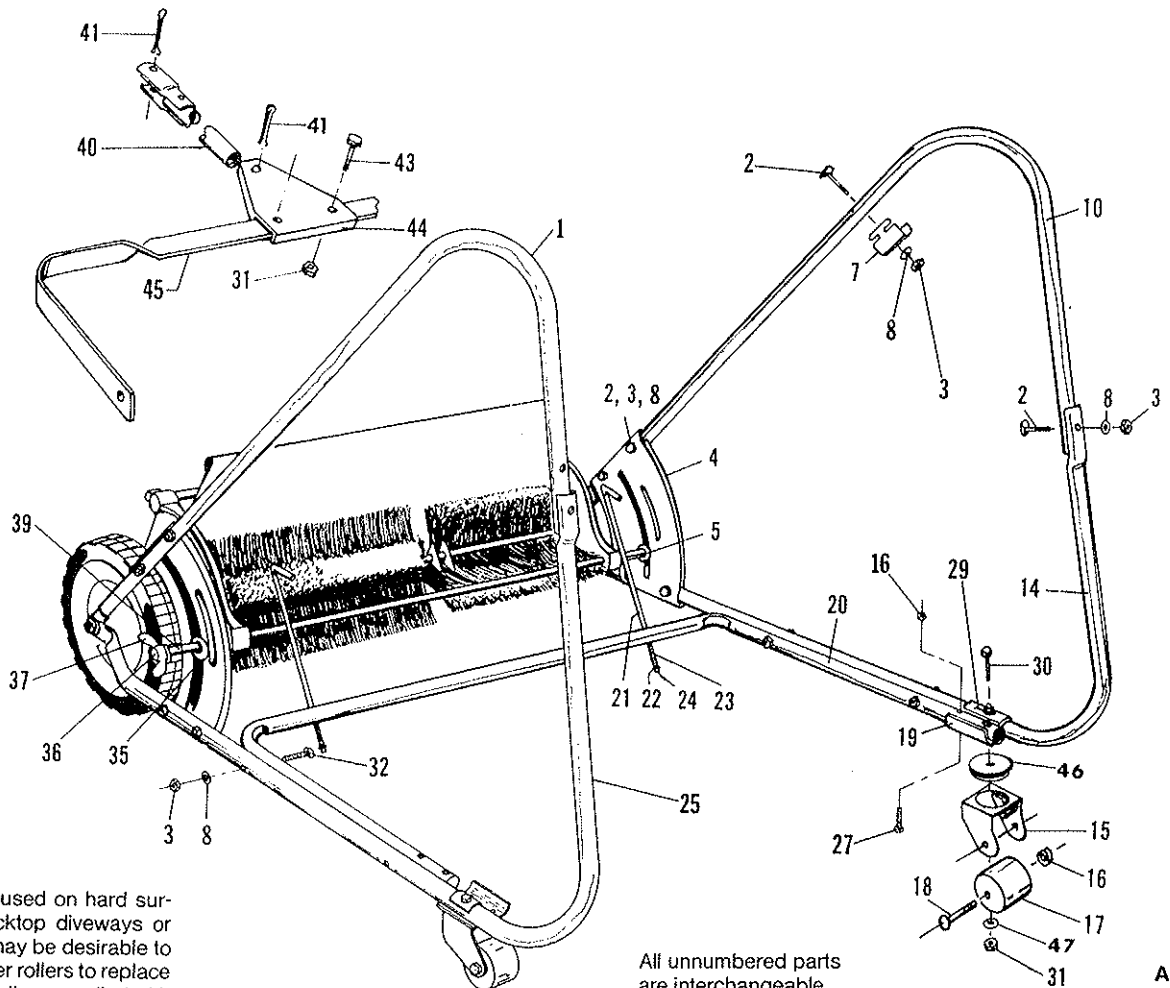

Note:

If this unit is to be used on hard surfaces such as blacktop driveways or concrete walks, it may be desirable to order 81-79-A caster rollers to replace the 76-58-A caster rollers supplied with the unit. The 76-58-A caster roller warranty is limited to lawn use only.

All unnumbered parts are interchangeable with the opposite side.

AF-100

SA-578-B

PARTS LIST

Ref. No.	Part No.	Qty. Per Unit	Description	Ref. No.	Part No.	Qty. Per Unit	Description
1	76-283-LC	1	Upper Frame L.H.	24	75-89-A	2	Retainer
2	69-416-20	12	Bolt, Contour Hd. 1/4-20 x 1 1/4	25	76-281-LC	1	Lower Frame L.H.
3	335-416	16	Nut, Plain Hex 1/4-20	27	65-416-20	4	Bolt, Hex Hd. 1/4-20 x 1 1/4
4	76-342-C	2	Brush Adjusting Bracket	29	59-77-A	2	Tube Clamp
5	945-616	2	Flatwasher, Plain 3/8	30	65-516-32	2	Bolt, Hex Hd. 5/16-18 x 2
7	76-240-A	2	Pivot Bracket	31	365-516	4	Nut, Hex Lock 5/16-18
8	935-416	16	Lockwasher, Spring 1/4	32	69-416-28	4	Bolt, Contour Hd. 1/4-20 x 1 3/4
10	76-284-RC	1	Upper Frame R.H.	35	945-516	3	Flatwasher, Plain 5/16
14	76-280-RC	1	Lower Frame R.H.	36	69-111-A	1	Adjusting Bolt
15	76-136-B	2	Caster Fork	37	73-71-A	1	Wing Nut
16	365-416	6	Nut, Hex Lock 1/4-20	39	55-160-A	1	Spacer
17	76-58-A	2	Caster Roller	40	75-32-B	1	Tongue
18	76-202-A	2	Axle	41	81-14-A	2	Clinch Pin
19	76-81-B	2	Caster Plate	43	65-516-16	2	Bolt, Hex Hd. 5/16-18 x 1
20	76-272-B	1	Frame Support	44	75-40-B	1	Hitch Plate
21	76-255-A	2	Basket Stop	45	75-134-B	1	Yoke
22	945-416	2	Flatwasher, Plain 1/4	46	78-130-A	2	Bearing
23	76-271-A	2	Compression Spring	47	82-138-B-1	2	Washer

BASKET ASSEMBLY

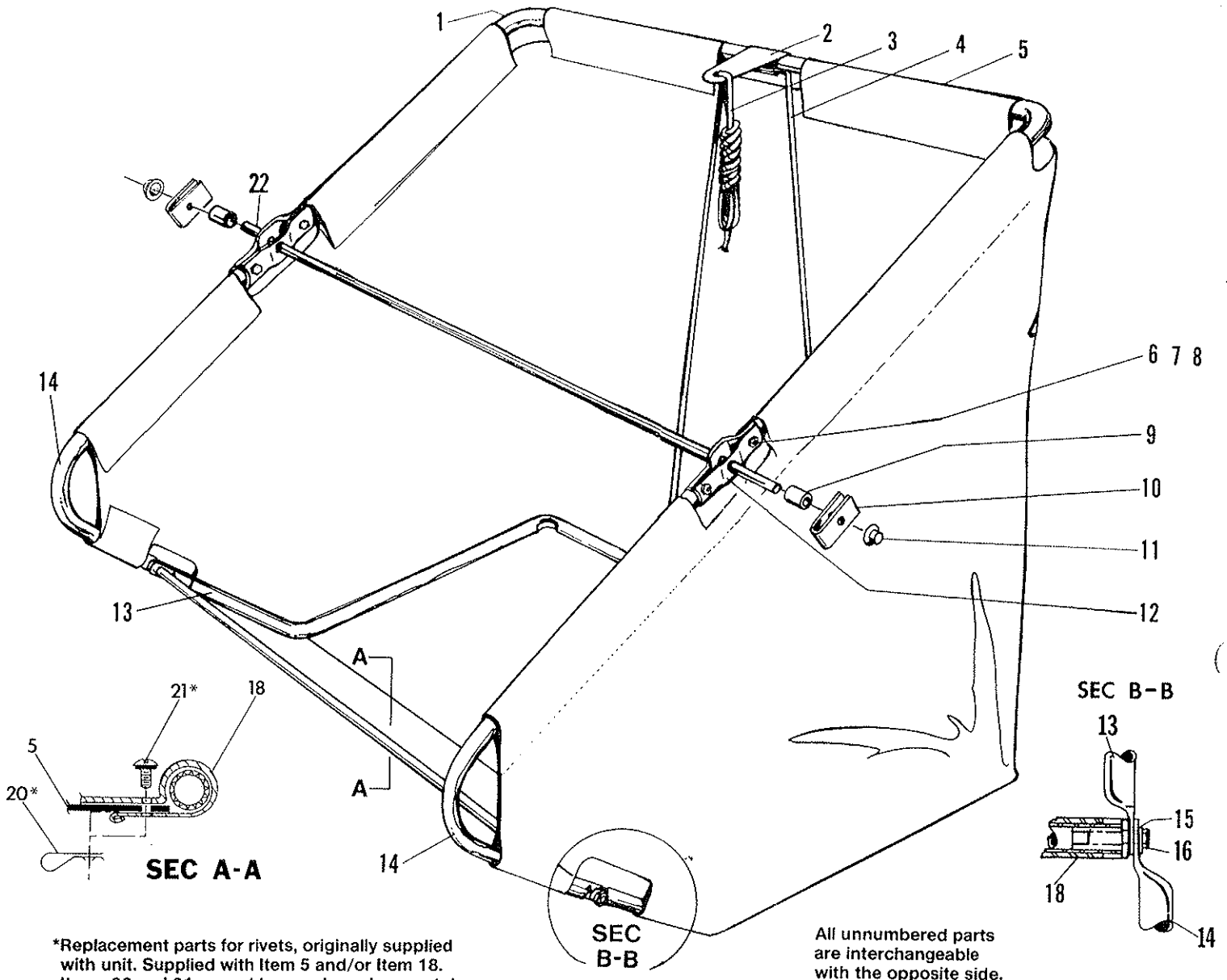

*Replacement parts for rivets, originally supplied with unit. Supplied with Item 5 and/or Item 18. Items 20 and 21 cannot be purchased separately.

All unnumbered parts are interchangeable with the opposite side.

AF-101

PARTS LIST

Ref. No.	Part No.	Qty. Per Unit	Description	Ref. No.	Part No.	Qty. Per Unit	Description
1	76-326-B	1	Rear Basket Frame	12	79-112-B	4	Pivot Bracket
2	76-252-A	1	Rope Clip	13	83-82-C	1	Lower Basket Frame
3	60-09-A	1	Rope	14	76-285-B	2	Front Basket Frame
4	83-33-B	1	Basket Spring	15	935-516	2	Lockwasher, Spring 5/16
5	SA-1211-C	1	Basket Replacement	16	65-516-12	2	Bolt, Hex Head 5/16-18 x 3/4
6	69-416-24	2	Bolt, Contour Head 1/4-20 x 1 1/2	18	SA-1093-B	1	Basket Clamp Replacement
7	936-416	4	Lockwasher, Int. Tooth 1/4	*20		5	Speed Nut 10-24
8	335-416	4	Nut, Plain Hex 1/4-20	*21		5	Machine Screw 10-24 x 1/2
9	73-414-A	2	Spacer	22	76-275-A	1	Pivot Rod
10	76-242-A	2	Pivot Latch	23	80-293-B	1	Wind Apron (Not Shown)
11	76-254-A	2	End Cap				

HOW TO ORDER REPAIR PARTS

The Model number will be found printed on the hood. Always mention the Model number when requesting service or ordering repair parts for your Lawn Sweeper.

The parts list will note that some parts are for the right side of the sweeper and some are for the left side. To determine the right and left side, stand behind your sweeper facing the direction the sweeper will move when in operation. The left side of your sweeper is at your left, and the right side of the sweeper is at your right side.

All parts listed in this book may be ordered from any authorized "Parker" dealer. However, if the parts you need are not stocked locally, you may order from Parker Sweeper Company, P.O. Box 1728, Springfield, Ohio 45501.

WHEN ORDERING REPAIR PARTS, ALWAYS GIVE THE FOLLOWING INFORMATION:

1. PART NUMBER (NOT THE REF. NO.)
2. PART DESCRIPTION
3. MODEL NUMBER (From the Hood)
4. NAME OF THE SWEEPER

