



Electronic Service Manuals

This electronic document is provided as a service to our customers. We do not create the contents of the information contained in this document. Should you have detailed questions pertaining to the information contained in this document, you may contact Michco, or the manufacturer which provided the original information in this electronic deliverable. Michco's only part in this electronic deliverable was the electronic assembly process. By providing this manual on line we are not guaranteeing parts availability.

You may contact Michco through the following methods:

Phone (517) 484-9312 or (800) 331-3339

2011 N. High St. -- Lansing, Michigan -- 48906

Fax: (517) 484-9836

Email: CustServe@Michco.com

Web site: www.Michco.Com

Parts Web site: www.FloorMachineParts.Com

Order Parts on Line at:

www.FloorMachineParts.Com

Directly to Parts & Service:

By Email: **Shop@Michco.com**

By Fax: (517) 702-2041

By Voice: Use numbers above.

Serving the Cleaning Industry Since 1922

Notice: All copyrighted material remains property of original owners, all trademarks are property of respective owners. Manuals are subject to Manufacturer's reproduction limitations. Originals or reproductions were provided by manufacturers through a request. We make no warranty as to the correctness of information provided in this document and you assume all risk. By placing these manuals on line we are not declaring our corporation to be an manufacturer authorized dealer or provider, please check our web site for authorized manufacturers we represent.

OWNER'S GUIDE



TE-8636 TRAILETTE

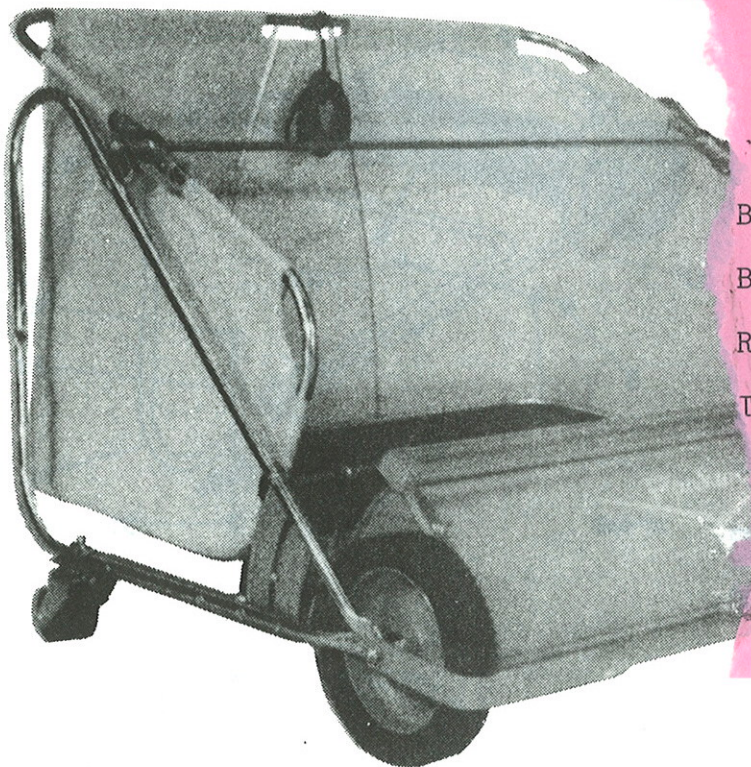

NOTICE

FOR THE PURPOSE OF SHIPPING, THIS BASKET IS TURNED INSIDE OUT. BEFORE ASSEMBLING, TURN THE BASKET RIGHT SIDE OUT. THE BASKET IS TURNED CORRECTLY WHEN THE BLACK LOSSY SURFACE IS ON THE OUTSIDE BOTTOM. LOGO MUST BE ON OUTSIDE OF BASKET RAILING REAR.

**BE SAFE. PROTECT YOUR FAMILY, YOUR FRIENDS, YOURSELF.
OBSERVE ALL SAFETY INSTRUCTIONS.**

**READ THESE INSTRUCTIONS BEFORE SETTING UP
AND OPERATING MACHINE.**

PARKER SWEEPER COMPANY

Box 1728

Springfield, Ohio 45501

Plate No. 1211

7/94
87-22-A

ASSEMBLY INSTRUCTIONS

YOUR SAFETY IS OUR CONCERN, READ ALL SAFETY RULES AND OPERATING INSTRUCTIONS BEFORE ATTEMPTING TO OPERATE THIS EQUIPMENT. FAILURE TO FOLLOW SAFETY RULES AND OPERATING INSTRUCTIONS MAY RESULT IN SERIOUS INJURY.

The unit covered by this owner's guide is shipped complete in one carton and will take a minimum amount of time and effort to assemble. Follow all assembly instructions carefully. Whenever the terms left hand, right hand or L.H., R.H. are used, it should be understood to mean from a position behind the unit in the direction of forward travel. All hardware is on the unit in its proper location. If something is missing, notify the dealer/distributor where unit was purchased. If unable to obtain parts locally, contact the Parker Sweeper Company.

GENERAL INFORMATION

1. Remove the unit and hardware carton from the main carton. Do Not discard any inserts until unit is completely assembled.
2. The hardware carton contains the tubing for the frame assembly, the basket assembly and the pivot rod assembly for the basket.

NOTE: Identification of these parts will be determined in instructions at point of assembly.

3. Read through the owner's guide once to familiarize yourself with the assembly procedure, maintenance and operation of the unit.
4. Many times the exploded views at the back of this owner's guide can aid in the assembly of the unit.

ASSEMBLING FRAME TO SWEEPER UNIT ASSEMBLY

NOTE: The numbers in parenthesis refer to those used in the adjoining AF-686, AF-687, AF-688 and exploded view for FRAME ASSEMBLY on plate number 1218 at the back of this owner's guide.

1. Remove two contour head bolts (32), lockwashers (8) and hex nuts (3) from the front sides of the frame support (20).
2. Align two holes in frame support (20) with the holes in the lower frame supports (10) and reassemble contour head bolts, lockwashers and nuts. (See AF-686, right).
3. Remove two contour head bolts (32), lockwashers (8) and hex nuts (3) from the rear ends of the frame support (20). Also remove the hex head bolts (30), tube clamps (29) and locknuts (31) from the caster plates (19).
4. Remove the two rear frame supports (14) from the hardware carton. Slide open end of rear frame supports (14) over small diameter of lower frame supports (10).
5. Align holes in rear ends of frame support (20) with the holes in the sides of rear frame supports (14) and reassemble the contour head bolts, lockwashers and hex nuts removed in step 3. (See AF-686, right).
6. Remove the two hex head bolts (43) and hex lock nuts (31) used to secure caster assemblies to the hitch yoke (45).
7. Remove caster assemblies, special washers (47) and bearings (46) from yoke (45).
8. Reassemble the hex head bolts and lock nuts to yoke (45) as they will be used later to assemble hitch tongue.
9. Using the hardware removed from caster plates (19) in step 3, and hardware from step 7, assemble casters as follows:
 - A. Place hex head bolt (30) through tube clamp (29).
 - B. Assemble hex head bolt down through hole in rear frame support (14) and caster plate (19).
 - C. Place bearing (46) on bolt with large diameter against caster plate.
 - D. Place caster assembly on bolt with small diameter of bearing through hole in top of caster fork (15).
 - E. Place special washer (47) on bolt against small diameter of bearing and secure with hex lock nut (31). (See AF-687, right).

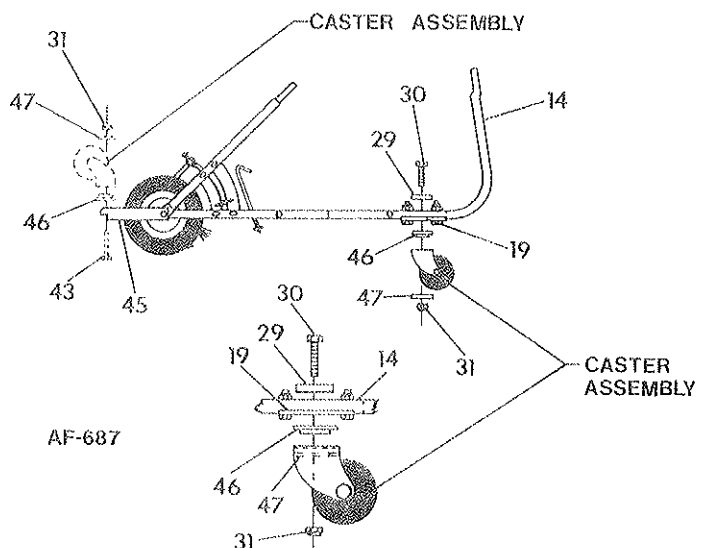
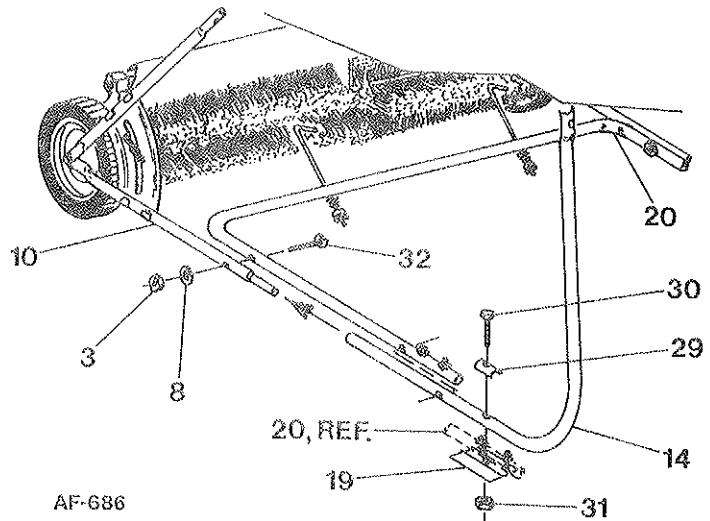

ASSEMBLY INSTRUCTIONS

NOTE: FAILURE TO OBSERVE SAFETY INSTRUCTIONS MAY RESULT IN SERIOUS INJURY.

ASSEMBLING FRAME TO SWEEPER UNIT ASSEMBLY (CONTINUED)

10. Remove the two upper frames (1) from the hardware carton.
11. When assembling the left and right hand upper frames the pivot brackets (7) must be to the inside of unit. (See AF-688, right).
12. Remove the contour head bolts (2), lockwashers (8) and hex nuts (3) from both ends of the upper frames.
13. With the pivot brackets (7) to the inside, slide front end of upper frame (1) over small diameter of lower frame (25). Place the back of upper frame in the curved end of rear frame support (14) and reassemble contour head bolts, lockwashers and nuts. (See AF-688, right).

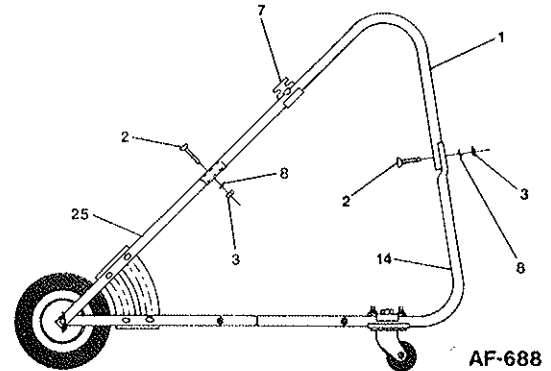

ASSEMBLING BASKET

NOTE: The numbers in parenthesis refer to those used in the adjoining AF-639, AF-640, AF-641, AF-642 and exploded view for BASKET ASSEMBLY on plate number 1219 at the back of this owner's guide.

1. Lay the basket assembly on a flat surface and unfold back, and sides, leaving as much of the basket bottom uncovered as possible.
2. Remove the lower basket frame-back (19) from the hardware carton. Place in basket against the bottom, to the back. (See AF-639, right).

NOTE: Be sure the two holes in tubing are on the top side when the frame is in place.

3. Remove the right (13) and left (17) hand lower basket frames from the hardware carton.
4. When the lower basket frames are in the proper location, the flattened ends are turned up and to the outside of basket. (See AF-639, right).
5. Slide the smaller diameter end of the lower basket frame into the end of lower basket frame-back (19).
6. Remove the two front basket frames (14) from the hardware carton. Remove the plastic cap from hex hd. bolt (16) and remove bolt (16) and lockwasher (15) from front basket frames (14). Do not remove lockwashers (15) from bolts (16).
7. Place long end of front basket frames (14) through the lower loop in front of basket and slide basket onto tube until the flattened end will start through the front loop in bottom of basket. (See AF-639, right).
8. Place bolts (16) through front basket frames (14) and lower basket frame (13) R.H. and (17) L.H.
9. Pull basket clamp (18) up so basket bottom bends to contour of lower basket frames. Lift lower basket frame back (19) above basket bottom to relieve stress on material and assemble bolts (16) in basket clamp (18) on both sides. (See AF-640, right).
10. Push the lower basket frame back (19) down against basket bottom and back of basket.
11. Remove the pivot rod assembly from the hardware carton.
12. Remove the four contour head bolts (6), lockwashers (7) and hex nuts (8) from the pivot brackets (12).
13. Place ends of rear basket frame (1) and front basket frames (14) between two pivot brackets (12 on each side of pivot rod (22)).
14. Align holes in brackets (12) with those in frames (1 and 14) and reassemble contour head bolts (6), lockwashers (7) and nuts (8). (See AF-641, right).

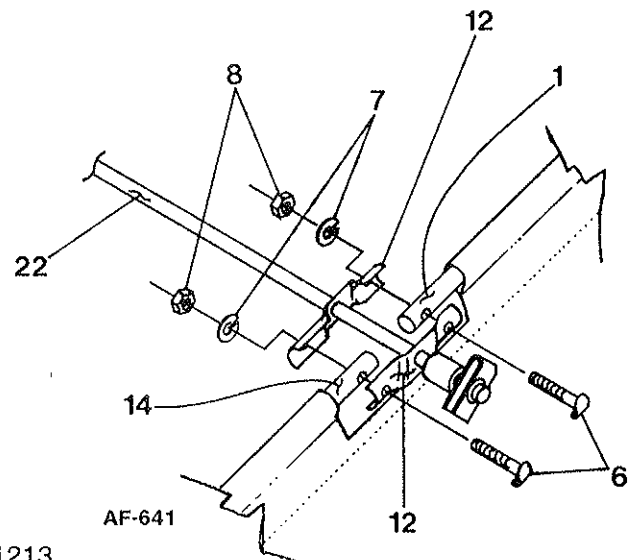
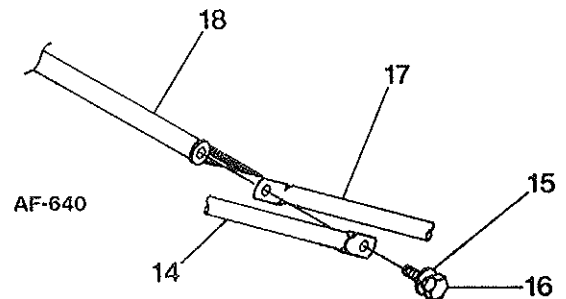
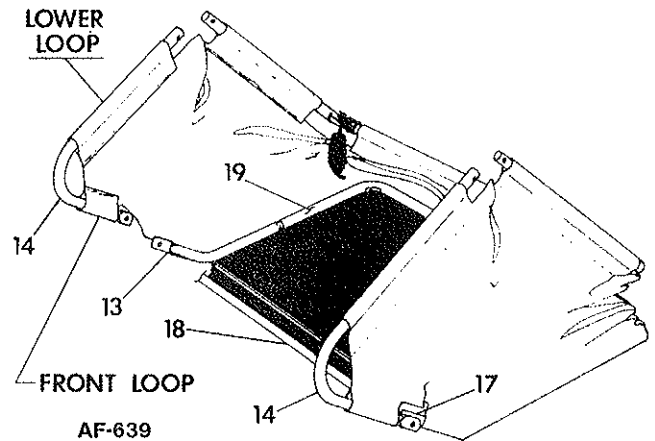

ASSEMBLY INSTRUCTIONS

SAFETY IS IMPORTANT! DO NOT IGNORE IT! OBSERVE IT! BE SAFE!

ASSEMBLING BASKET (CONTINUED)

15. Remove the rope clip (2) and rope (3) from the corner of the rear basket frame (1) and reattach clip (2) and rope (3) to center of frame (1). Rope must be to inside of basket.
16. Remove the basket spring (4) from the hardware carton.
17. Lift back of basket up and insert ends of spring (4) into holes in top of lower basket frame-back (19) while placing top of spring (4) against rear basket frame (1), underneath rope clip. (See AF-642, right).
18. Push rope clip (2) down to assist snapping the spring (4) into the notch on the under side of the rear basket frame (1).
19. With spring (4) in place, push the rope clip (2) up to lock spring in position. If spring (4) is bowed to the inside of basket, push it back to lay against back of basket. (See AF-642, right).
20. Basket is now ready to assemble to Sweeper Unit and Frame Assembly.

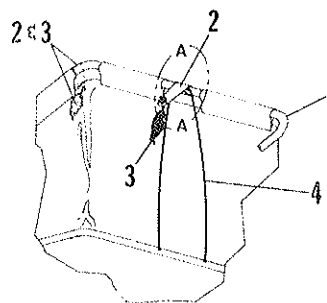

ASSEMBLING BASKET TO UNIT

NOTE: The numbers in parenthesis refer to those used in the adjoining AF-645 and exploded view for Basket Assembly on plate number 1219 at the back of this owner's guide.

1. Place basket between the two upper frames with the basket opening toward the sweeper unit assembly.
2. With the pivot latches (10) upright, place pivot rod (22) in the TOP SLOT of pivot brackets. (See AF-645, right).

NOTE: The pivot latches (10) must straddle the pivot brackets (See AF-645, right).

3. Push the pivot latches (10) forward and down over the pivot brackets to lock basket in place.

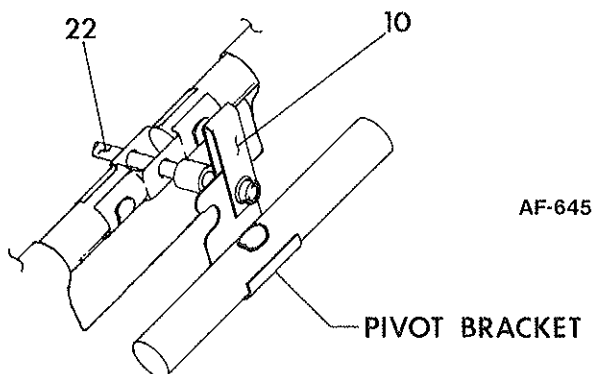

ASSEMBLING HITCH TO YOKE

NOTE: The numbers in parenthesis refer to those used in the adjoining AF-689 and exploded view for FRAME ASSEMBLY on plate number 1218 at the back of this owner's guide.

1. Remove hitch tongue (40) and hitch plate (44) from hardware package.
2. Remove the two hex head bolts (43) and hex lock nuts (31) from the hitch yoke (45).
3. Place hitch plate (44) down over the center of hitch yoke (45), align holes and reassemble hex hd. bolts (43) and lock nuts (31). (See AF-689, right).
4. Remove the two clinch pins (41) taped to hitch tongue (40).
5. Align hole in tube end of hitch tongue (40) with hole in front of hitch plate (44) and insert one clinch pin (41) to secure tongue to plate.
6. Place hitch to hitch plate of tractor and secure with other clinch pin (41).

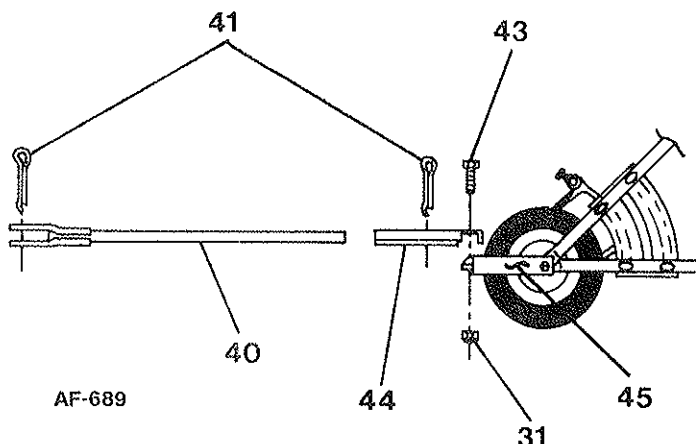

OPERATING INSTRUCTIONS

OPERATED SPEED

- A. Moving the sweeper forward rotates the brushes, propelling the leaves, clippings, etc., into Basket.
- B. Select a forward travel speed that provides efficient sweeping without throwing debris over the back of Basket.

OPERATING INSTRUCTIONS

READ SAFETY & OPERATING INSTRUCTIONS BEFORE OPERATING EQUIPMENT

CAUTIONS

- A. The Basket has been designed for holding a large capacity of dry grass clippings. When grass clippings are wet or freshly cut, caution should be exercised on the amount picked up. The Basket could be overloaded and make dumping difficult.
- B. **DANGER:** Do not hold dumping rope in hand while towing. Secure loose end to tractor behind operator. Do not allow rope to contact brushes, as it may become tangled in reel shaft causing damage to the unit and possible injury to operator. (See AF-690, below).
- C. **CAUTION!** This sweeper is not designed to haul people, animals or equipment. Severe damage to the sweeper and possible injury to people or animals may result if this warning is ignored.
- D. **NOTE:** When basket is empty caution must be taken on rough (uneven) terrain. Travel slowly to prevent possible upsetting of the sweeper (tipping forward) when moving over gravel driveways, rutted turf, curb areas, bits of broken tree limbs, twigs, mole runs or other interferences. Traveling too fast over rough areas may cause the sweeper wheels to be blocked causing the sweeper to upset.

BRUSH HEIGHT ADJUSTMENT

- A. To raise Brushes to extreme height, loosen the large Wing Nut, pull Sweeping Unit forward as far as slots in Brush Adjustment Brackets will permit. To lower Brushes to lowest position push Sweeping Unit backwards as far as slots will permit. Secure Wing Nut when desired brush adjustment is obtained.
- B. For grass clippings or leaves, adjust Brushes to highest position. After trial run on lawn, should the setting be too high, lower slightly and try again until correct setting is found. Brush life may be prolonged by adjusting so contact with ground is light. The lighter the contact, the longer the wear and ease in pulling.
- C. The most efficient operating height is when brushes just contact the top of the grass or make light contact with paved surfaces. When brushes are set too low, the sweeper will pull hard. This will lead to excessive brush wear and require premature brush replacement. Always have brushes in the raised position when transporting sweeper.
- D. **REMEMBER:** Brushes set too low may cause the sweeper handle to pivot forward striking tractor or operator, resulting in damage to tractor or injury to operator.
- E. **NOTE:** If the Brushes do not rotate and the Wheels slide when the Sweeper is being pulled, the Brushes are set too low.

HOOD ADJUSTMENT

- A. The hood can be adjusted to change the deflection of the material being handled by loosening the wing nuts on both sides of the hood and sliding the hood up or down.
- B. If sweeping at a high rate of speed the hood should be raised to deflect the material to the back of basket. If set too low the material could be thrown over the back of basket.
- C. If sweeping at a low rate of speed the hood should be set lower until material goes to the back of basket.

DUMPING BASKET

- A. The load is dumped by pulling Basket forward with rope, causing Basket to pivot into a semi-inverted position. When load is discharged, allow rope and Basket to return to its normal position.

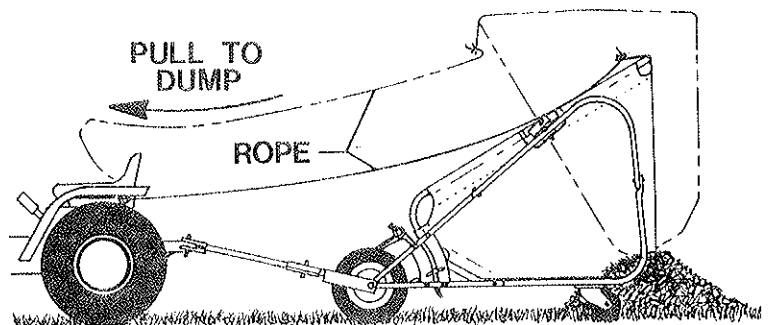

AF-690

OPERATING INSTRUCTIONS

OBSERVE SAFETY RULES AT ALL TIMES. DON'T TAKE CHANCES!

SWEEPING TIPS

- A. Use sweeper in early spring to give your lawn a healthful cleaning.
- B. Use sweeper after mowing to remove turf clippings and give the lawn a blanket like effect.
- C. Sweep often in fall as leaves are dropping. Do not wait until leaves are all off trees,
- D. For best sweeping results keep lawn cut short. When sweeping turf clippings do not overload Basket. Turf clippings are heavy and overloading Basket will put unnecessary stress on Basket.
- E. To reduce the number of loads required when picking up leaves, it may be easier to mow over the leaf area at your normal mowing height before using the sweeper. The mowing will break up the leaves allowing them to compact when picked up with the sweeper. This may reduce your leaf loads to approximately one quarter the number required when picking up whole leaves.

USING WIND APRON

The Wind Apron is furnished with the unit. This is used to keep the sweepings in the basket on windy days or when sweeping at a fast speed. The Wind Apron is stretched across the basket and tied on the frame as shown at the top corner and middle at the pivot bracket.

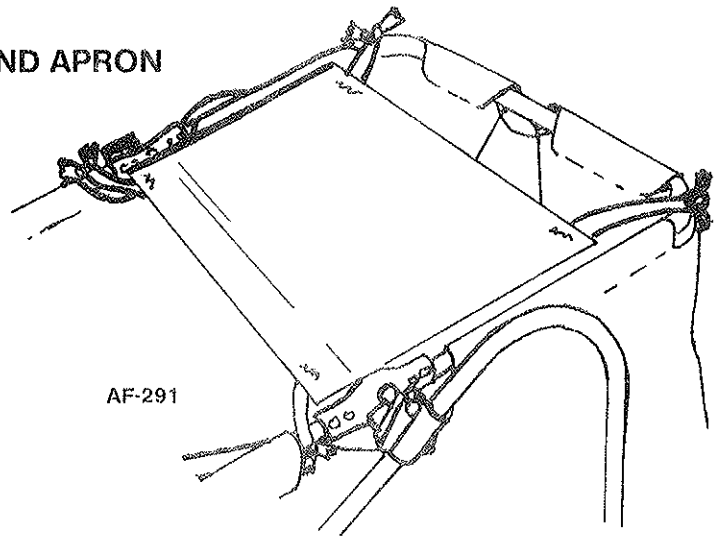

MAINTENANCE INSTRUCTIONS

LUBRICATION

- A. Occasional lubrication of the Sweeper will lengthen the service life.
- B. Check grease in wheels before operating unit. Each wheel has a grease fitting in the hub near axle. Add grease until it is forced through gap of hub at axle.
- C. Place a few drops of oil in the Swivel Bearings and Axle of the Casters every time the machine is used.

GREASE FITTING

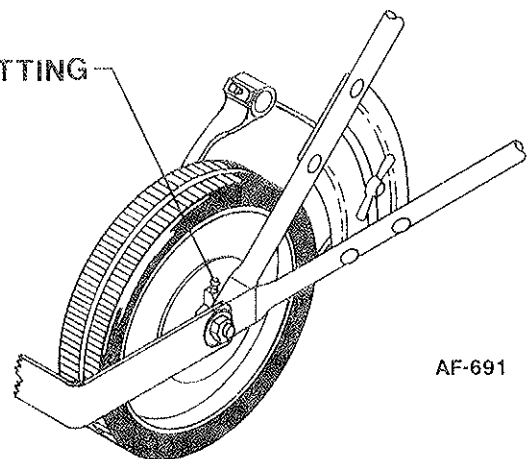

CLEANING HOOD AND BASKET

- A. Wet grass clippings have a tendency to dry and adhere to the inner face of the hood; it is important to keep this face clean for good sweeping action.
- B. The Basket should always be emptied immediately after each time the sweeper is used.
- C. If the grass or leaves being picked up are wet; wipe basket out with a soft cloth after dumping.
- D. Keeping the basket clean and dry will lengthen its service life.
- E. Clean hood and basket with warm soapy water, wipe dry with clean soft cloth.

MAINTENANCE INSTRUCTIONS

READ SAFETY & OPERATING INSTRUCTIONS BEFORE OPERATING EQUIPMENT

BRUSH CARE AND REPLACEMENT

Brush Removal

Should the bristles take a set from use, reverse the Brushes on the Reel Shaft. Never allow the Brush Bristles to remain in a bent position on any object for any length of time as they can take a set.

- Turn the sweeper upside down on a workbench or the ground.
- Notice the brush stud has a collar fitting against one of the brush brackets holding it against the reel shaft.
- Remove the hex nuts and brush clamps from the end of the studs, on the sides with the collar.
- Remove the brushes from the brush bracket slots.
- Remove the hex nuts and brush clamps from the opposite end of the studs, but DO NOT remove the speed nut (this would allow the stud to fall out of reel shaft releasing the brush brackets).

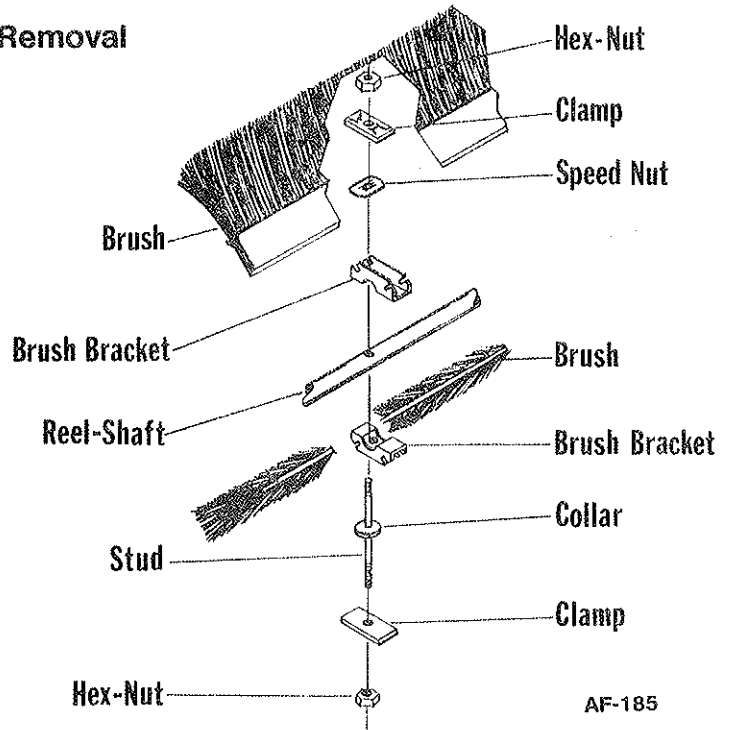

To Replace Brushes

- Turn the reel shaft to position the brush strips in the slots of the brush brackets that are held on the stud by the speed nut.
- Position the brush clamps and finger tighten hex nuts. Be sure brushes are all the way down in all the brush brackets.
- Brushes will be staggered with a slight overlap. Tighten lock nuts to assure brushes will be held firmly in place.
- Turn the reel shaft so the installed brush strips are on the bottom.
- Repeat the sequence of installation for the remaining four brushes.
- Tighten all nuts, torque to 50 to 55 inch pounds.

STORAGE

- Clean basket to remove clippings and debris.
- Wipe dirt and grease from the chassis. Repaint scratched areas and coat metal parts with oil to prevent rust.
- Store Sweeper in a dry area out of direct sunlight.
- Check sweeper parts for wear. Replace parts as necessary.
- Remove the basket assembly from the sweeper, release the basket spring and fold as shown.
- Remove the bolts, washers and nuts holding the upper and lower frames together, and fold as shown.
- The drawing shows the head assembly flat against a wall with the tongue tied to an anchor screw or nail in the wall. Tie a cord through the upper basket frame near the rope clip and hang it flat against the wall from an anchor screw or nail.

AF-97

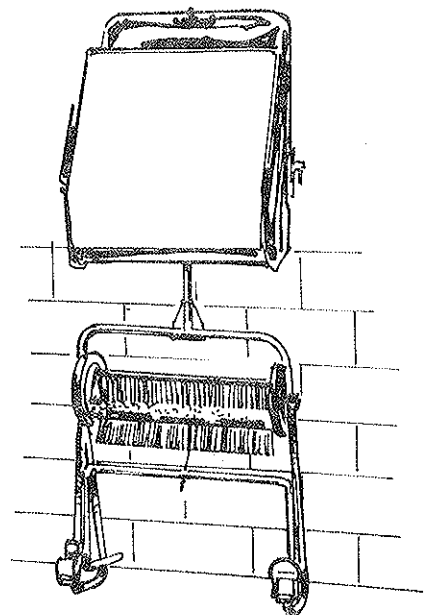

HOW TO RE-INSTALL PINIONS IN MANUAL OR TRAILING SWEEPERS

If for some reason you have found it necessary to remove the pinions, you should carefully follow these instructions. All parts must be clean before assembling.

- (1) To assist you, we suggest using a piece of wood doweling or plastic material $\frac{5}{8}$ " diameter, 2" long as shown. Each pinion is different as indicated by the part number and must be returned to the correct side of the shaft.

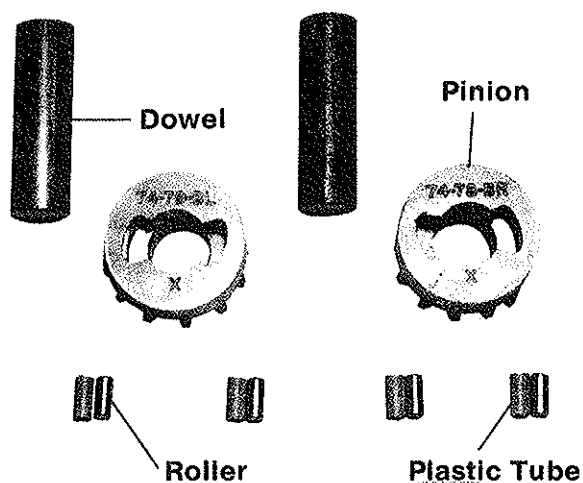

- (2) Insert the wooden dowel into the pinion.

- (3) Identify your pinion part number and insert the metal rollers. Place the plastic tubing in the cavity between the metal roller and the wall of the cavity. You may have to force the plastic tubing into this space but it is resilient and is supposed to fit tightly.

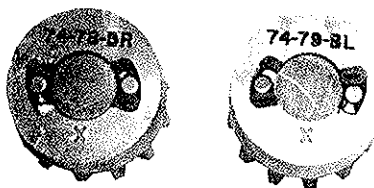

- (4) Pinion with part number **74-79 BL** is to be replaced on the **left side** of the shaft. Part number **74-78 BR** is for the **right side**. Line up the pinion (leaving the dowel in place) with the shaft as shown.

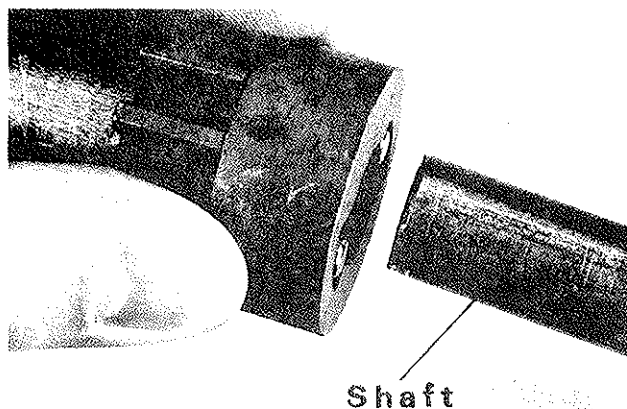

- (5) Push the pinion onto the shaft which will force the dowel to back out of the pinion. This will leave the rollers and plastic tubes in their proper position.

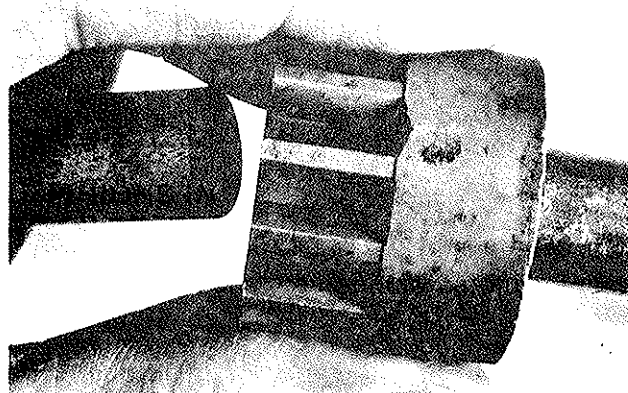

- (6) Apply a coating of grease on the outside of the wheel gear teeth. Do not grease inside pinion as this will cause pawl springs to be ineffective.

NOTE! The right and left side are determined from the operators position.

SWEEPER UNIT ASSEMBLY

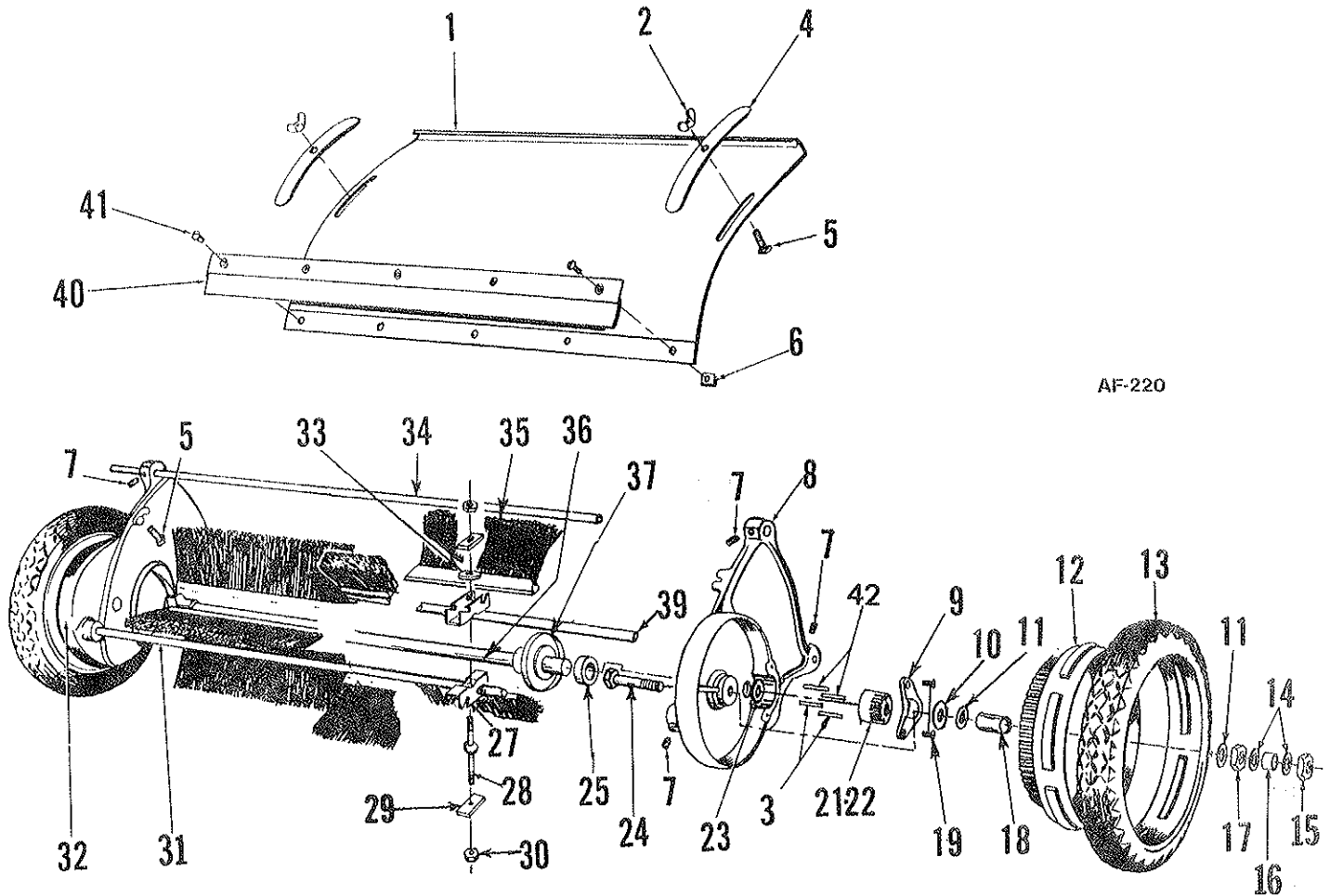

AF-220

PARTS LIST

Ref. No.	Part No.	Qty. Per Unit	Description	Ref. No.	Part No.	Qty. Per Unit	Description
1	86-75-D 90-03	1	Hood & Silkscreen	22	74-78-RB *	1	Right Hand Pinion
2	351-516-20	2	Wing Nut 5/16-18	23	50-33-A	2	Special Washer
3	76-37-A *	4	Pawl Spring	24	53-35-A	2	Axle
4	49-11-A	2	Hood Clamp	25	68-60-A	2	Ball Bearing
5	65-516-12	2	Bolt, Hex Hd. 5/16-18 x 3/4	27	74-13-C	8	Brush Bracket
6	346-10	5	Speed Nut # 10-24	28	74-16-A	4	Brush Stud
7	560-C-516-10	6	Set Screw 5/16-18 x 5/8	29	69-04-A	8	Brush Clamp
8	76-339-LF	1	Left Hand Side Plate	30	362-416	8	Hex. Lock Nut 1/4-20
9	80-01-B	2	Pinion Cover	31	68-33-A	1	Front Tie Rod
10	946-816-16	2	Fiber Washer	32	76-338-R.F	1	Right Hand Side Plate
11	58-05-A	4	Special Washer	33	75-89-A	4	Retainer
12	58-14-D-1	2	Wheel	34	68-34-A	1	Top Tie Rod
13	75-88-C	2	Tire	35	1200-17-B	8	Brush Strip
14	945-816	4	Flatwasher, Plain 1/2	36	79-103-B	1	Reel Shaft
15	368-816	2	Nut, Hex Lock (Thin) 1/2-20	37	74-166-B	2	Dust Cover
16	68-44-A	2	Axle Spacer	39	76-341-A	1	Adjusting Tube
17	326-816	2	Nut, Plain Hex (Thick) 1/2-20	40	68-37-B 90-28	1	Hood Extension
18	58-06-A	2	Sleeve	41	515-10-8	5	Screw, Rd. Hd. Mach. #10-24 x 1/2
19	72-416-6	4	Bolt, Hex Hd. 1/4-20 x 3/8	42	74-80-A *	4	Pawl
21	74-79-LB *	1	Left Hand Pinion				

FRAME ASSEMBLY

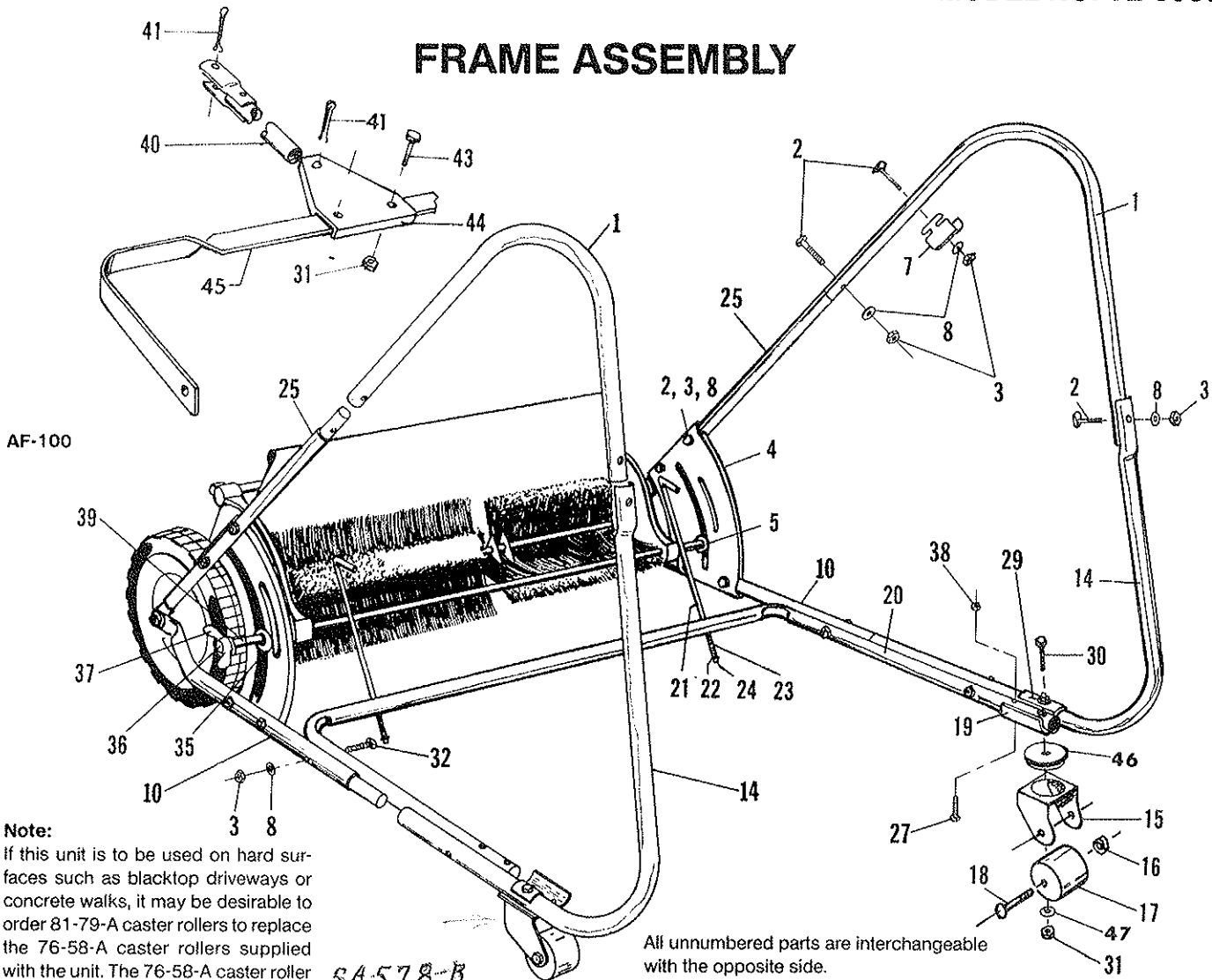

Note:
If this unit is to be used on hard surfaces such as blacktop driveways or concrete walks, it may be desirable to order 81-79-A caster rollers to replace the 76-58-A caster rollers supplied with the unit. The 76-58-A caster roller warranty is limited to lawn use only.

All unnumbered parts are interchangeable with the opposite side.

PARTS LIST

Ref. No.	Part No.	Qty. Per Unit	Description	Ref. No.	Part No.	Qty. Per Unit	Description
1	86-53-D	2	Upper Frame	24	75-89-A	2	Retainer
2	69-416-20	14	Bolt, Contour Hd. 1/4-20 x 1 1/4	25	86-52-C	2	Lower Frame
3	335-416	18	Nut, Plain Hex 1/4-20	27	65-416-16	4	Bolt, Hex Hd. 1/4-20 x 1
4	76-342-C	2	Brush Adjusting Bracket	29	59-77-A	2	Tube Clamp
5	945-616	2	Flatwasher, Plain 3/8	30	65-516-32	2	Bolt, Hex Hd. 5/16-18 x 2
7	76-240-A	2	Pivot Bracket	31	365-516	4	Nut, Hex Lock 5/16-18
8	935-416	18	Lockwasher, Spring 1/4	32	69-416-28	4	Bolt, Contour Hd. 1/4-20 x 1 3/4
10	86-41-C	2	Lower Frame Support	35	945-516	3	Flatwasher, Plain 5/16
14	86-51-D	2	Rear Frame Support	36	69-111-A	1	Adjusting Bolt
15	76-136-B	2	Caster Fork	37	73-71-A	1	Wing Nut
16	365-416	2	Nut, Hex Lock 1/4-20	38	364-416	4	Nut, Hex Lock (Thin) 1/4-20
17	76-58-A	2	Caster Roller	39	55-160-A	1	Spacer
18	76-202-A	2	Axle	40	75-32-B	1	Tongue
19	76-81-B	2	Caster Plate	41	81-14-A	2	Clinch Pin
20	76-272-B	1	Frame Support	43	65-516-16	2	Bolt, Hex Hd. 5/16-18 x 1
21	76-255-A	2	Basket Stop	44	75-40-B	1	Hitch Plate
22	945-416	2	Flatwasher, Plain 1/4	45	75-130-B	1	Yoke <i>75-134-B</i>
23	76-271-A	2	Compression Spring	46	78-130-A	2	Bearing
				47	50-230-A	2	Washer

BASKET ASSEMBLY

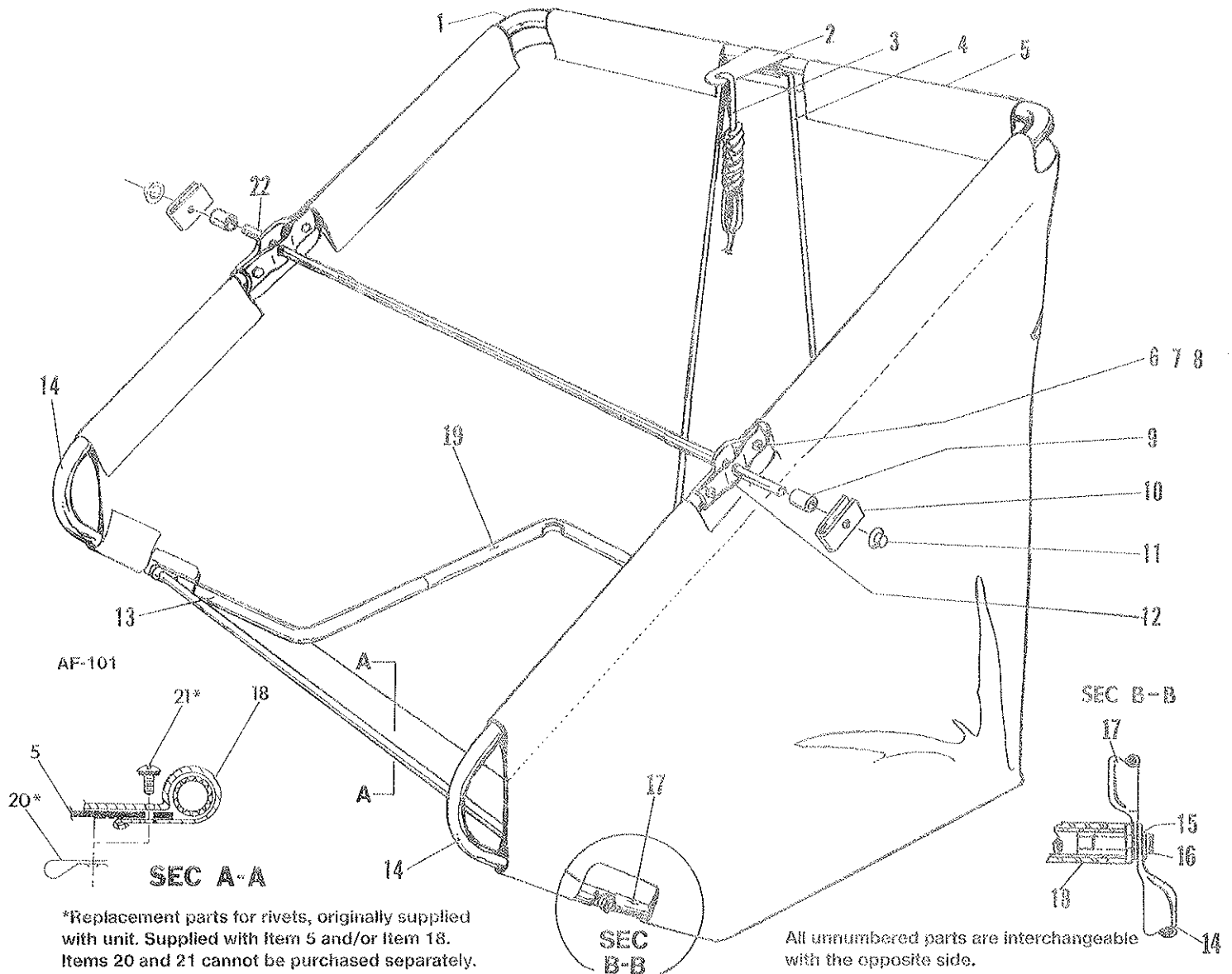

PARTS LIST

Ref. No.	Part No.	Qty. Per Unit	Description	Ref. No.	Part No.	Qty. Per Unit	Description
1	76-326-B	1	Rear Basket Frame	13	86-55-C	1	Lower Basket Frame R.H.
2	76-252-A	1	Rope Clip	14	76-285-B	2	Front Basket Frame
3	60-09-A	1	Rope	15	935-516	2	Lockwasher, Spring 5/16
4	83-33-B	1	Basket Spring	16	65-516-12	2	Bolt, Hex Head 5/16-18 x 3/4
5	SA-1211-C	1	Basket Replacement	17	86-54-C	1	Lower Basket Frame L.H.
6	69-416-24	4	Bolt, Contour Head 1/4-20 x 1 1/2	18	SA-1093-B	1	Basket Clamp Replacement
7	936-416	4	Lockwasher, Int. Tooth 1/4	19	86-56-D	1	Lower Basket Frame Back
8	335-416	4	Nut, Plain Hex 1/4-20	*20		5	Speed Nut 10-24
9	73-414-A	2	Spacer	*21		5	Machine Screw 10-24 x 1/2
10	76-242-A	2	Pivot Latch	22	76-275-A	1	Pivot Rod
11	76-254-A	2	End Cap	23	80-293-B	1	Wind Apron (Not Shown)
12	79-112-B	4	Pivot Bracket				

HOW TO ORDER REPAIR PARTS

The Model number will be found printed on the hood. .Always mention the Model number when requesting service or ordering repair parts for your Lawn Sweeper.

The parts list will note that some parts are for the right side of the sweeper and some are for the left side. .To determine the right and left side, stand behind your sweeper facing the direction the sweeper will move when in operation. .The left side of your sweeper is at your left, and the right side of the sweeper is at your right side.

All parts listed in this book may be ordered from any authorized "Parker" dealer..However, if the parts you need are not stocked locally, you may order from Parker Sweeper Company, P.O. Box 1728, Springfield, Ohio 45501.

WHEN ORDERING REPAIR PARTS, ALWAYS GIVE THE FOLLOWING INFORMATION:

1. .PART NUMBER (NOT THE REF. NO.)
2. .PART DESCRIPTION
3. .MODEL NUMBER (From the Hood)
4. .NAME OF THE SWEEPER