



Electronic Service Manuals

This electronic document is provided as a service to our customers. We do not create the contents of the information contained in this document. Should you have detailed questions pertaining to the information contained in this document, you may contact Michco, or the manufacturer which provided the original information in this electronic deliverable. Michco's only part in this electronic deliverable was the electronic assembly process. By providing this manual on line we are not guaranteeing parts availability.

You may contact Michco through the following methods:

Phone (517) 484-9312 or (800) 331-3339

2011 N. High St. -- Lansing, Michigan -- 48906

Fax: (517) 484-9836

Email: CustServe@Michco.com

Web site: www.Michco.Com

Parts Web site: www.FloorMachineParts.Com

Order Parts on Line at:

www.FloorMachineParts.Com

Directly to Parts & Service:

By Email: **Shop@Michco.com**

By Fax: (517) 702-2041

By Voice: Use numbers above.

Serving the Cleaning Industry Since 1922

Notice: All copyrighted material remains property of original owners, all trademarks are property of respective owners. Manuals are subject to Manufacturer's reproduction limitations. Originals or reproductions were provided by manufacturers through a request. We make no warranty as to the correctness of information provided in this document and you assume all risk. By placing these manuals on line we are not declaring our corporation to be an manufacturer authorized dealer or provider, please check our web site for authorized manufacturers we represent.

Minuteman[®]
Parker[®]

SU8336

**36" Trailing
Lawn Sweeper**

Suburbanite

OPERATION

SERVICE

PARTS

CARE

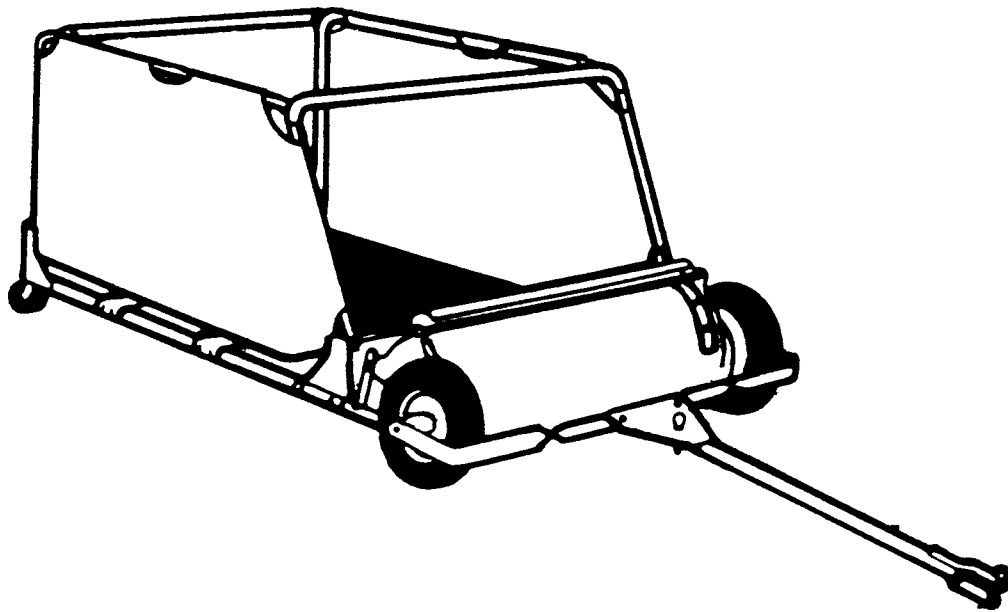

ASSEMBLY INSTRUCTIONS

YOUR SAFETY IS OUR CONCERN. READ ALL SAFETY RULES AND OPERATING INSTRUCTIONS BEFORE ATTEMPTING TO OPERATE THIS EQUIPMENT. FAILURE TO FOLLOW SAFETY RULES AND OPERATING INSTRUCTIONS MAY RESULT IN SERIOUS INJURY.

The unit covered by this owner's guide is shipped complete in one carton and will take a minimum amount of time and effort to assemble. Follow all assembly instructions carefully. Whenever the terms left hand, right hand, or L.H., R.H. are used, it should be understood to mean from a position behind the unit in the direction of forward travel. All hardware is on the unit in its proper location. If something is missing, notify the dealer/distributor where unit was purchased. If unable to obtain parts locally, contact the Parker Sweeper Company.

GENERAL INFORMATION

1. Remove the unit from carton. Do Not discard the carton or any of its inserts or packing until the unit is completely assembled.
2. All parts will be identified in instructions at point of assembly.
3. Read through the owner's guide once to familiarize your self with the assembly procedure, maintenance and operation of the unit.
4. Many times the exploded views at the back of this owner's guide can aid in the assembly of the unit.

ASSEMBLING BASKET

NOTE: The numbers in parenthesis refer to those used in the adjoining AF-697, AF-698, AF-699, AF-700 and exploded view for BASKET ASSEMBLY on plate number 739 at the back of this owner's guide.

1. Remove basket assembly from frame of unit and set to one side.
2. Remove the rear basket frame (18), two basket side frames upper (19) and the rear support rod (17) taped to the under side of frame on unit.
3. Remove the contour hd. bolts (3), lockwashers (4) and hex nuts (5) from the upper sides of rear basket frame (18). Also remove the hex hd. bolts (16) and hex lock nuts (15) from the lower ends.
4. Slide rear basket frame (18) through the loop in the rear of the gasket assembly (11), making sure that the two ends of frame are to the inside of basket assembly (11).
5. Loosen the hex hd. bolts (13) until threaded from the basket bottom support (27). Do Not Remove.
6. On one side of basket, pull hex hd. bolt (13) out just beyond spacer (23). Place end of rear basket frame (18) between spacer (23) and basket side frame bottom (6) or (12).
7. Align holes and reinsert bolt (13) through rear basket frame (18), spacer (23) and reassemble into basket bottom support (27) but Do Not Tighten.
8. Repeat for opposite side and tighten both bolts (13).
9. Insert hex. hd. bolts (16), removed in Step 3, into the holes in lower ends of rear basket frame (18) from the inside of the basket.
10. At the point the bolts (16) hit the basket material, mark a spot on the back side of basket.
11. Using a utility knife or other sharp instrument, cut a small "X" in the basket material to allow the bolts (16) to extend through basket material.
12. With bolts (16) in place, assemble rear support rod (17) onto bolts (16) and secure with hex lock nuts (15).

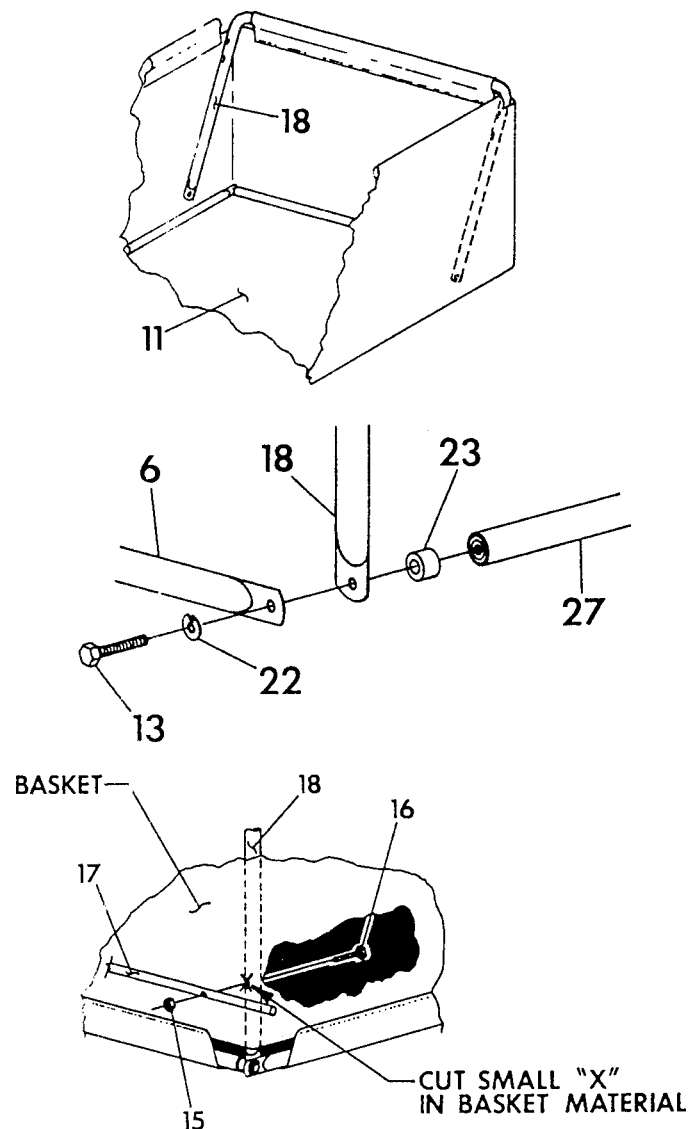

ASSEMBLY INSTRUCTIONS

SAFETY IS IMPORTANT! DO NOT IGNORE IT! OBSERVE IT! BE SAFE!

ASSEMBLING BASKET (CONTINUED)

1. Slide one basket side frame upper (19) through the two loops in the top of basket assembly (11) on both sides. NOTE: 90° bend in basket side frames upper (19) must be to the back of basket.
2. Assemble contour hd. bolts (3), removed in Step 3, into upper holes in rear basket frame (18) by pushing basket material away from frame and inserting bolts through holes from rear side of frame.
3. Assemble back of basket side frames upper (19) onto contour hd. bolts (3) and secure with lockwashers (4) and hex nuts(5).
4. Remove hex nuts (5) and lockwashers (4) from top sides of front basket brace (1). Do Not remove contour hd. bolts (3). 17. Assemble front of basket side frames upper (19) onto contour hd. bolts (3) and secure with lockwashers (4) and hex nuts (5).

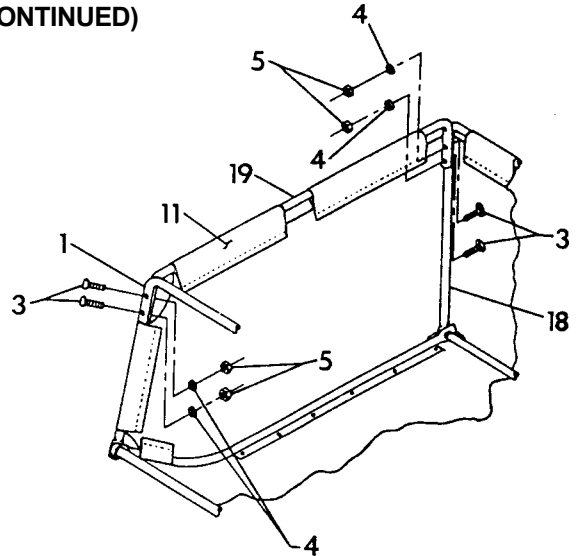

ASSEMBLING BASKET TO UNIT

NOTE: The numbers in parenthesis refer to those used in the adjoining AF-703 and exploded view for basket assembly on plate number 739 and frame assembly on plate number 740 at the back of this owner's guide.

1. Set basket assembly frame of unit.
2. Check all four corners to make sure the front and rear support rods (10) & (17) are properly seated in the corner supports (1).

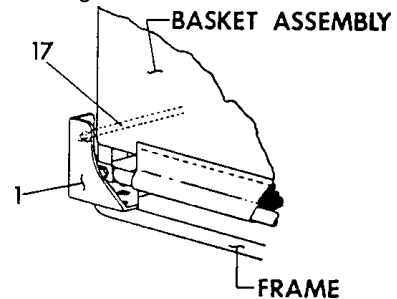

ASSEMBLING HITCH

NOTE: The numbers in parenthesis refer to those used in the adjoining AF-704 and the exploded view for hitch assembly on plate number 741 at the back of this owner's guide.

1. Remove hitch assembly from adjusting tube on sweeper head.
2. Remove the two hex hd. bolts (4) and hex lock nuts (5) from hitch plate (1) on hitch assembly.
3. Place hitch assembly in front of unit with hitch plate (1) resting on top of yoke (6).
4. Align holes hitch plate (1) with those in yoke (6) and reassemble hex hd. bolts (4) and hex lock nut (5).

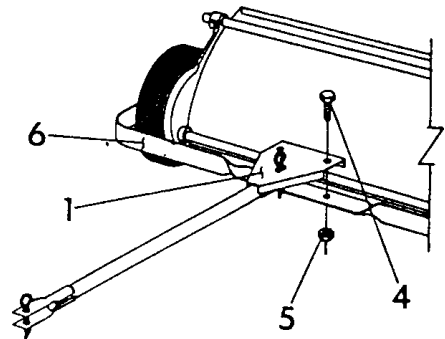

ASSEMBLING WIND APRON

1. Lay wind apron out on floor with silkscreen upward.
2. Start end of wind apron with hooks up through space between hood and upper tie rod.
3. Pull wind apron up over front basket brace and attach hooks to rear basket frame.
4. Dowel rod in wind apron will stop against side plate.

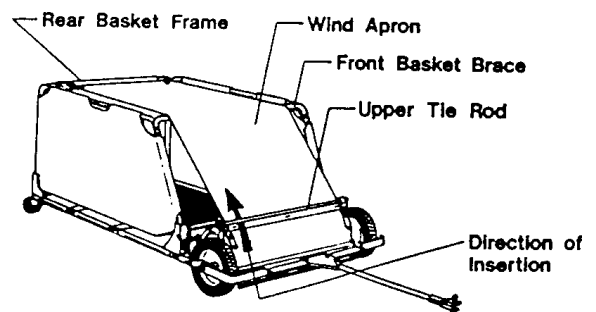

OPERATING AND MAINTENANCE INSTRUCTIONS

READ SAFETY & OPERATING INSTRUCTIONS BEFORE OPERATING EQUIPMENT

CAUTIONS

- A. The basket has been designed for holding a large capacity of dry grass clippings. When grass clippings are wet or freshly cut, caution should be exercised on the amount picked up. The basket could be overloaded and make dumping difficult.
- B. **CAUTION!** This sweeper is not designed to haul people, animals or equipment. Severe damage to the sweeper and possible injury to people or animals may result if this warning is ignored.
- C. **NOTE:** When basket is empty caution must be taken on rough (uneven) terrain. Travel slowly to prevent possible upsetting of the sweeper (tipping forward) when moving over gravel driveways, rutted turf, curb areas, bits of broken tree limbs, twigs, mole runs or other interferences. Traveling too fast over rough areas may cause the sweeper wheels to be blocked causing the sweeper to upset.

BRUSH HEIGHT ADJUSTMENT

- A. To raise brushes to extreme height, loosen the plastic knob, pull sweeping unit forward as far as slots in brush adjustment brackets will permit. To lower brushes to lowest position push sweeping unit backwards as far as slots will permit. Secure knob when desired brush adjustment is obtained.
- B. The most efficient operating height is when brushes just contact the top of the grass or make light contact with paved surfaces. When brushes are set too low, the sweeper will pull hard. This will lead to excessive brush wear and require premature brush replacement. Always have brushes in the raised position when transporting sweeper.
- C. **NOTE:** If the brushes do not rotate and the wheels slide when the sweeper is being pulled, the brushes are set too low.

HOOD ADJUSTMENT

- A. The hood can be adjusted to change the deflection of the material being handled, by loosening the wing nuts on both sides of the hood and sliding the hood up or down.
- B. If sweeping at a high rate of speed the hood should be raised to deflect the material to the back of basket.
- C. If sweeping at a low rate of speed the hood should be set lower until material goes to the back of basket.

SWEEPING TIPS

- A. Use sweeper in early Spring to give your lawn a healthful cleaning.
- B. Use sweeper after mowing to remove turf clippings and give the lawn a blanket like effect.
- C. Sweep often in Fall as leaves are dropping. Do not wait until leaves are all off trees.
- D. To reduce the number of loads required when picking up leaves, it may be easier to mow over the leaf area at your normal mowing height before using the sweeper. The mowing will break up the leaves allowing them to compact when picked up with the sweeper. This may reduce your leaf loads to approximately one quarter the number required when picking up whole leaves.

BRUSH CARE AND REPLACEMENT

Brush Removal

Should the bristles take a set from use, reverse the brushes on the reel shaft. Never allow the brush bristles to remain in a bent position on any object for any length of time as they can take a set.

- A. Turn the sweeper upside down on a workbench or the ground.
- B. Notice the brush stud has a collar fitting against one of the brush brackets holding it against the reel shaft.
- C. Remove the hex nuts and brush clamps from the end of the studs, on the sides with the collar.
- D. Remove the brushes from the brush bracket slots.
- E. Remove the hex nuts and brush clamps from the opposite end of the studs, but **DO NOT** remove the speed nut (this would allow the stud to fall out of reel shaft releasing the brush brackets).

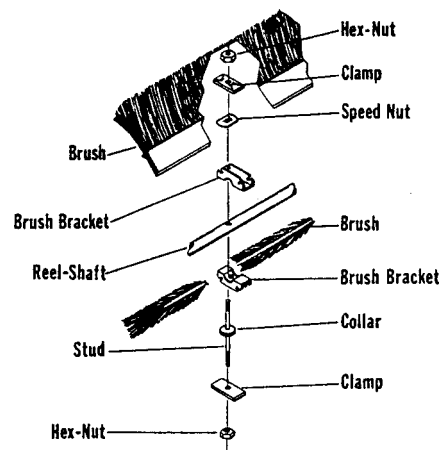

To Replace Brushes

- A. Turn the reel shaft to position the brush strips in the slots of the brush brackets that are held on the stud by the speed nut.
- B. Position the brush clamps and finger tighten hex nuts. Be sure brushes are all the way down in all the brush brackets.
- C. Brushes will be staggered with a slight overlap. Tighten lock nuts to assure brushes will be held firmly in place.
- D. Turn the reel shaft so the installed brush strips are on the bottom.
- E. Repeat the sequence of installation for the remaining four brushes.
- F. Tighten all nuts, torque to 50 to 55 inch pounds.

LUBRICATION

- A. Occasionally lubrication of the sweeper will lengthen the service life.
- B. Check grease in wheels before operating unit. Each wheel has a grease fitting in the hub near axle. Add grease until it is forced through gap of hub at axle.
- C. Place a few drops of oil in the swivel bearings and axle of the casters every time the machine is used.

HOW TO RE-INSTALL PINIONS IN MANUAL SWEEPERS

If for some reason you have found it necessary to remove the pinions, you should carefully follow these instructions. All parts must be clean before assembling.

1. To assist you, we suggest using a piece of wood doweling or plastic material 5/8" diameter, 2" long as shown. Each pinion is different as indicated by the part number and must be returned to the correct side of the shaft.

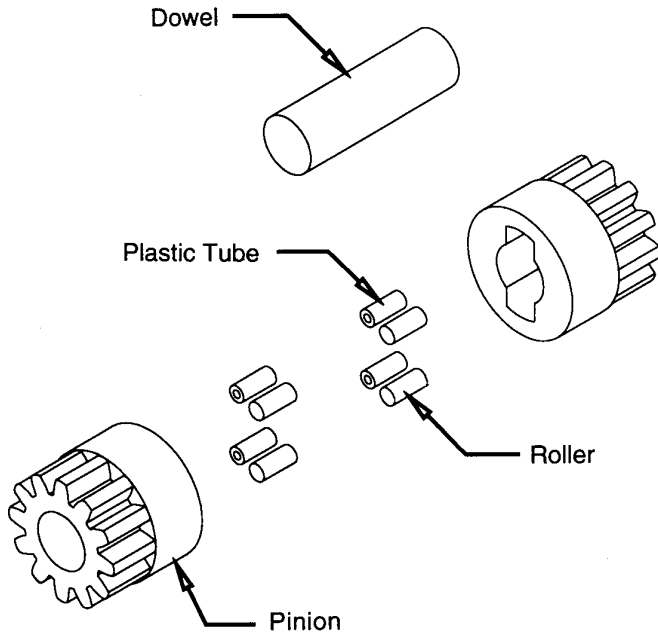

2. Insert the wooden dowel into the pinion.
3. Identify your pinion part number and insert the metal rollers. Place the plastic tubing in the cavity between the metal roller and the wall of the cavity. You may have to force the plastic tubing into this space but it is resilient and is supposed to fit tightly.

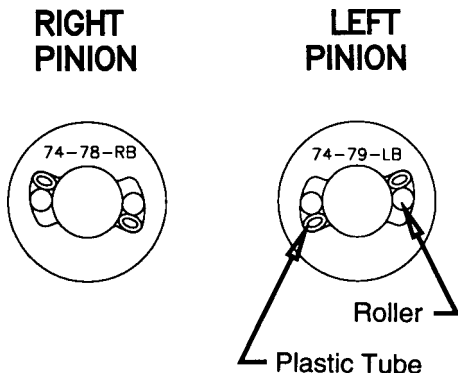

NOTE: The right and left side are determined from the operators position.

4. Pinion with part number 74-79 BL is to be replaced on the left side of the shaft. Part number 74-78 BR is for the right side. Line up the pinion (leaving the dowel in place) with the shaft as shown.

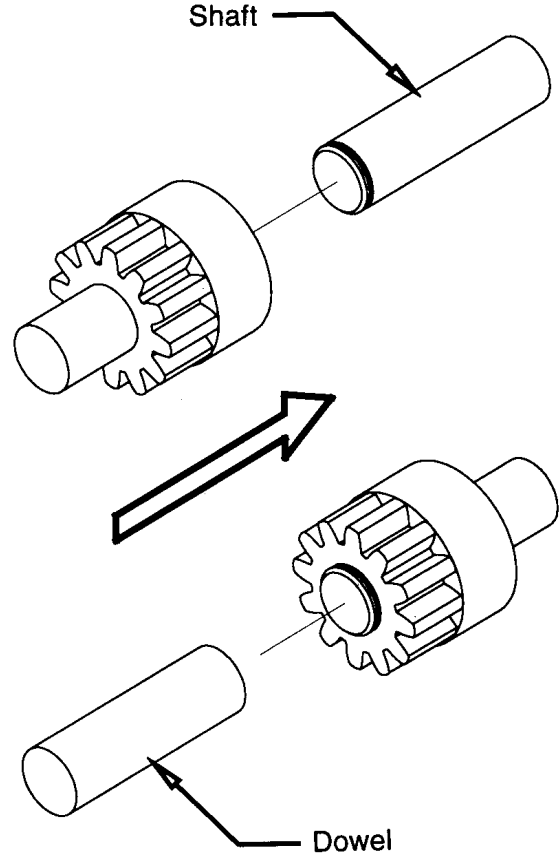

5. Push the pinion onto the shaft which will force the dowel to back out of the pinion. This will leave the rollers and plastic tubes in their proper position.
6. Apply a coating of grease on the outside of the wheel gear teeth. Do not grease inside pinion as this will cause pawl springs to be ineffective.

SWEEPER UNIT ASSEMBLY

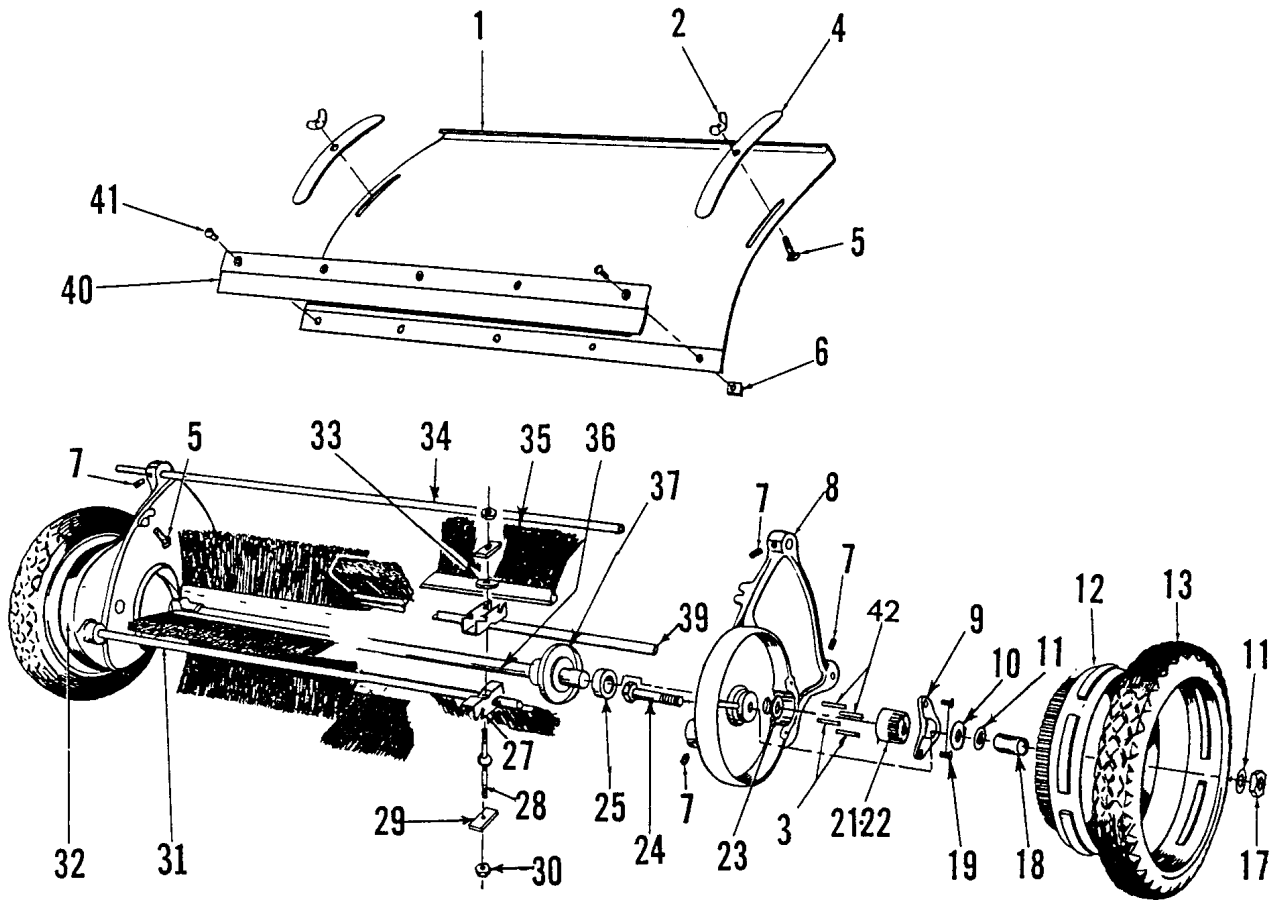

PARTS LIST

Item	Part No.	Qty.	Description	Item	Part No.	Qty.	Description
1	68-58PTD	1	Hood Parker Red	22	74-78-RB	1	Pinion Right
2	351-516-20	2	Wing Nut	23	50-33-A	2	WSR-Special
3	76-37-A	4	Pawl Spring	24	53-35-A	2	Axle Belt
4	49-11-A	2	Hood Clamp TE SU	25	68-60-A	2	Bearing
5	713026	4	BLT-HH 5/16-18 x 3/4 #5	27	74-13-C	8	Bracket
7	560C516-10	6	Square Head Set Screw	28	74-16-C	4	Stud
8	76-339-LF	1	Side Plate LH	29	69-04-A	8	Clamp Brush Strip
9	80-01-B	2	Cover Pinion	30	362-416	8	Nut Hex Self-Locking
10	946-816-16	2	Fibre Washer	31	68-33PLT	1	Tie Rod
11	58-05-A	4	Washer	32	76-338-RF	1	Side Plate RH
12	58-14PTD	2	Wheel Hub	33	75-89-A	4	Speed Nut
13	75-88-C	2	Tire Only	34	68-34PLT	1	Tie Rod
13A	SA-609-C	1	Tire Assy. Includes 12 & 13	35	1200-17-B	8	Brush Assembly TE
17	368-816	2	Half Nut Nyloc 1/2-20	35A	BK-11	1	Brush Kit Includes Mtg. Hrdw.
18	58-06-A	2	Sleeve	36	79-103-B	1	Reel Shaft
19	506-416-10	4	SCR FH 1/4-20 x 5/8	37	74-166PLT	2	Dust Cover
21	74-79-LB	1	Pinion Left	39	80-141PLT	1	Adj. Tube
21A	SA-1580-B	1	Pinion Kit Inc. 3, 21, 22, 42	42	74-80-A	4	Pawl

FRAME ASSEMBLY

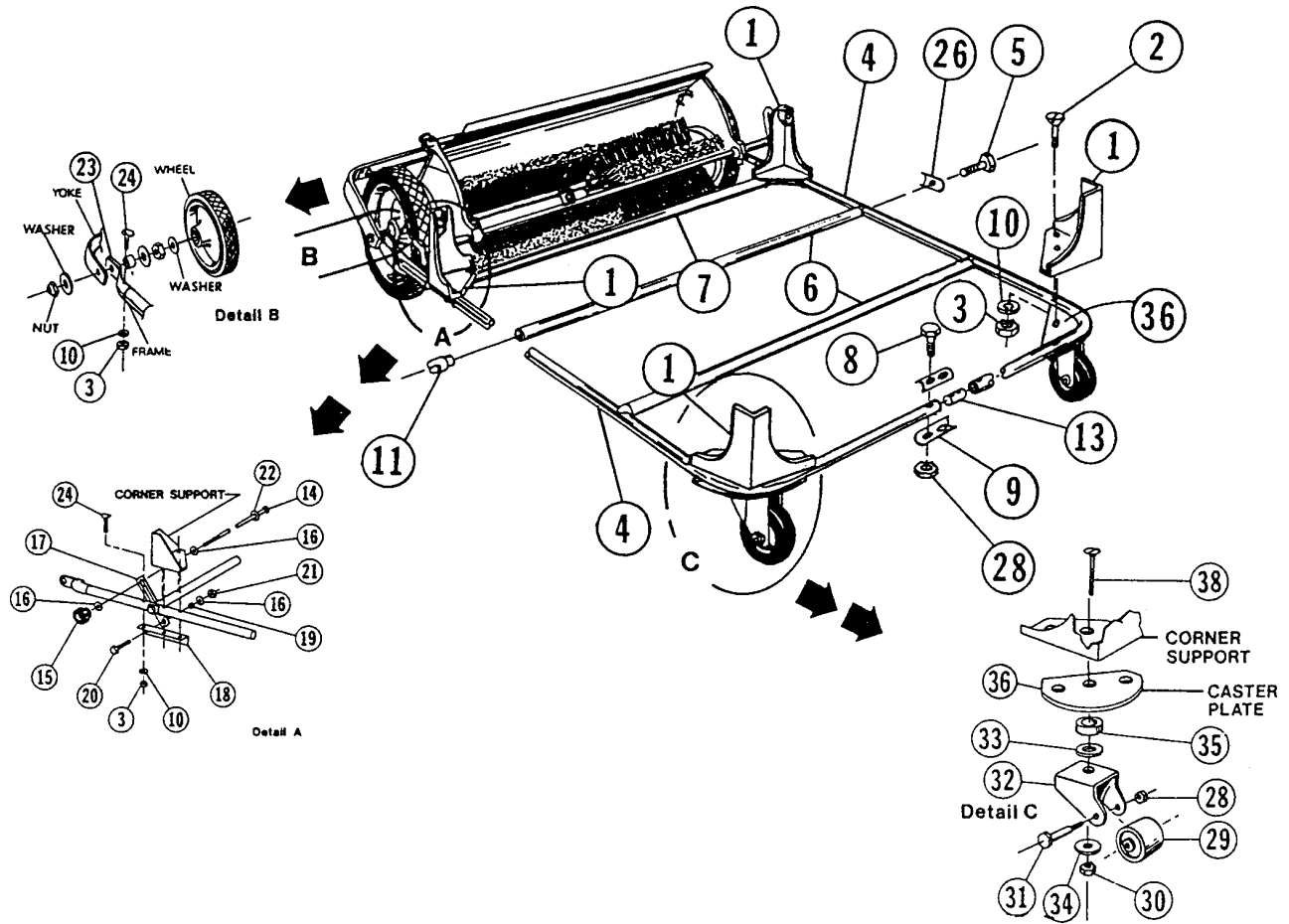

PARTS LIST

Item	Part No.	Qty.	Description	Item	Part No.	Qty.	Description
1	80-130-C	4	Corner Support	20	713026	2	BLT-HH 5/16-18 x 3/4 #5
2	505-416-32	10	Flat Hd. Mach. Screw	21	711374	2	Nut-Nyloc 5/16-18
3	711316	14	Nut-Hex 1/4-20 ST PL	22	711508	2	WSR-Flat .44 x 1.00 x .08
4	80-126-B	2	Frame Side	23	81-116-A	2	Tubing End Cap
5	713008	6	BLT-HH 1/4-20 x 2 1/4 #5	24	69-416-24	4	BLT-Cont. Hd. 1/4-20 x 1.5
6	SA-834-B	2	Mid Cross Back Assy.	26	80-181-A	6	Bracket Clamp
7	SA-835-C	1	Front Cross Brace Assy.	28	711373	4	Nut-Nyloc 1/4-20
8	713005	2	BLT-HH 1/4-20 x 1 1/2 #5	29	76-58-A	2	Roller
9	82-12-B	2	Clamp, Complete	30	711374	2	Nut-Nyloc 5/16-18
10	711544	14	WSR-Helical 1/4	31	76-202-A	2	Axle 3/8D x 2.06
11	81-172-A	6	Tube Connector	32	76-136-B	2	Caster Fork
13	80-147-A	6	Tube Insert	32A	SA-578-B	1	Caster Assy. Incl. 28,32,31,29
14	80-158-A	1	Adj. Bolt	33	78-130-A	2	Bearing
15	79-94-A	1	Fluted Knob	34	82-138-B-1	2	Special Washer
16	711506	4	WSR-Flat 5/16 ST PL	35	57-105-A	2	Spacer
17	59-59-A	2	Bracket Brush Adj.	36	82-02PTD	2	Caster Plate
18	81-105-B	2	Angle Bracket	38	505-516-40	2	Flat Hd. Screw
19	54-227-A	2	Spacer				

HITCH ASSEMBLY

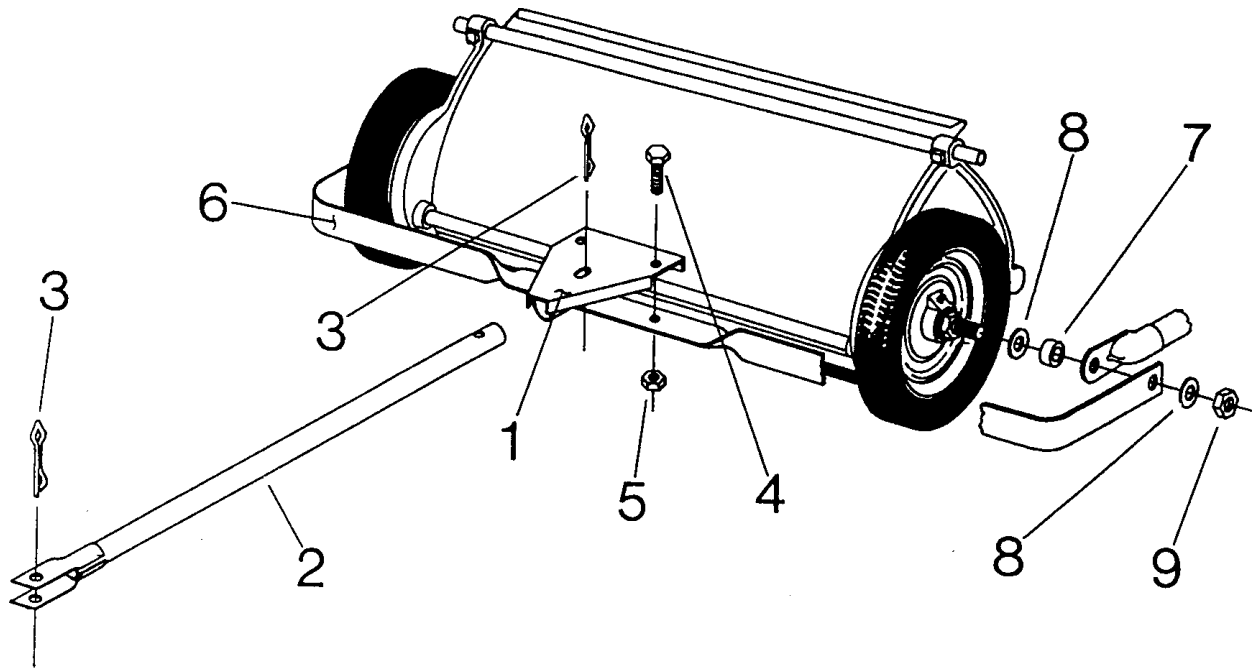

PARTS LIST

Item	Part No.	Qty.	Description
1	75-40-B	1	Hitch Plate Weldment
2	75-32-B	1	Tounge Weldment
3	81-14-A	2	Clinch Pin
4	713027	2	BLT-HH 5/16-18 x 1 #4
5	711374	2	Nut-Nyloc 5/16-18
6	75-134-B	1	Yoke
7	68-44-A	2	Spacer Axle
8	711509	4	WSR-Flat 1/2 ST PL
9	368-816	2	Half Nut Nyloc 1/2-20

BASKET ASSEMBLY

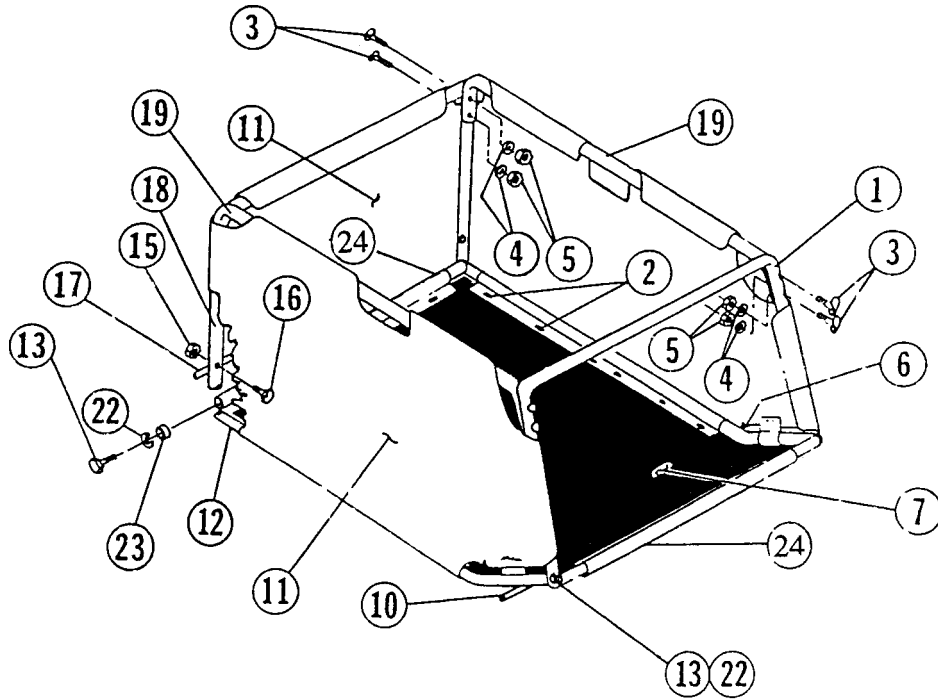

NOTE: To replace basket sides or bottom, drill out rivets ② in bottom using 3/16" dia. drill.

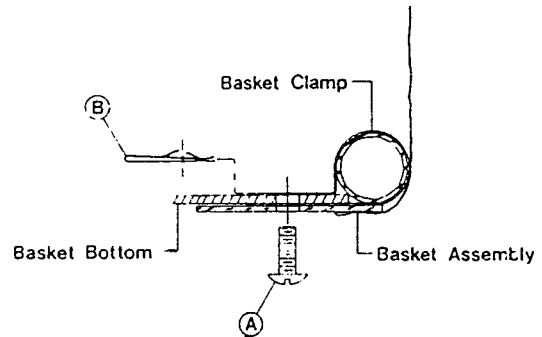

PARTS LIST

Item	Part No.	Qty.	Description	Item	Part No.	Qty.	Description
1	82-87-B	1	Front Basket Brace	15	711373	4	Nut-Nloc 1/4-20
2	92-28	20	Bulb Tite Rivet	16	713005	4	BLT-HH 1/4-20 X 1 1/2 #5
3	69-416-32	8	BLT-Cont. Hd. 1/4-20 X 2	17	86-105-B	1	Support Rod Rear
4	711544	8	WSR-Helical 1/4	18	82-86-B	1	Rear Upright
5	711316	8	Nut-Hex 1/4-20 ST PL	19	80-137-B	2	Frame Basket Side Top
6	SA-1590-C	1	Bracket Clamp Assy.	22	711545	4	WSR-Helical 5/16
7	SA-1593-B	1	Basket Bottom Replacement	23	81-120-A	2	Spacer
10	80-139PLT	1	Front Support Rod ZP	24	SA-1427-B	2	Bottom Basket Clamp Assy.
11	SA-1592-1	1	Basket Replacement	xxx	SA-1057-1	1	Basket Assembly SU
12	SA-1591-B	1	Basket Clamp Assy.				(includes items 1,2, 6,7,10, 11,24)
13	713027	4	BLT-HH 5/16-18 X 1 #5	xxx	SA-1556-1	1	Wind Apron Assy. Comp.

xxx - Not Shown

For complete Basket Assembly including all parts shown order Part Nos. SA-1057-1 and SA-1091-B.

LIMITED WARRANTY

The Parker Sweeper Company warrants to the original purchaser/user that this product is free from defects in workmanship and materials under normal use and service for a period of two years from date of purchase. In addition, Parker Sweeper Company, will, at its option, honor labor warranty claims for the first 12 months from date of sale, provided such claims are submitted through and approved by factory authorized repair stations. Parker Sweeper Company, will, at its option, repair or replace without charge, except for transportation costs, parts that fail under normal use and service when operated and maintained in accordance with the applicable operation and instruction manuals.

This warranty does not apply to normal wear, or to items whose life is dependent on their use and care, such as belts, cords, switches, hoses, rubber parts, electrical motor components or adjustments. Parts not manufactured by Parker Sweeper Company such as engines, batteries, battery chargers, hydraulic pumps, and tires are covered by and subject to the warranties and/or guarantees of their manufacturers. Please contact Parker Sweeper Company for procedures in warranty claims against these manufacturers.

Special warning to purchaser — Use of replacement filters and/or prefilters not manufactured by Parker Sweeper Company or its designated licensees, will void all warranties expressed or implied.

A potential health hazard exists without exact original equipment replacement.

All warranted items become the sole property of Parker Sweeper Company or its original manufacturer, whichever the case may be.

Parker Sweeper Company disclaims any implied warranty, including the warranty of merchantability and the warranty of fitness for a particular purpose. Parker Sweeper Company assumes no responsibility for any special, incidental or consequential damages.

This limited warranty is applicable only in the U.S.A. and Canada, and is extended only to the original user/purchaser of this product. Customers outside the U.S.A. and Canada should contact their local distributor for export warranty policies. Parker Sweeper Company is not responsible for costs or repairs performed by persons other than those specifically authorized by Parker Sweeper Company. This warranty does not apply to damage from transportation, alterations by unauthorized persons, misuse or abuse of the equipment, use of non-compatible chemicals, or damage to property, or loss of income due to malfunctions of the product.

If a difficulty develops with this machine, you should contact the dealer from whom it was purchased.

This warranty gives you specific legal rights, and you may have other rights which vary from state to state. Some states do not allow the exclusion or limitation of special, incidental or consequential damages, or limitations on how long an implied warranty lasts, so the above exclusions and limitations may not apply to you.



A Minuteman International Company

World Headquarters

Minuteman International, Inc.
111 South Rohlwing Road
Addison, Illinois 60101

Minuteman Canada, Inc.
2210 Drew Road
Mississauga, Ontario
L5S 1B1

(630) 627-6900
FAX (630) 627-1130

(905) 673-3222
FAX (905) 673-5161

988386
Printed in U.S.A.