



## Electronic Service Manuals

This electronic document is provided as a service to our customers. We do not create the contents of the information contained in this document. Should you have detailed questions pertaining to the information contained in this document, you may contact Michco, or the manufacturer which provided the original information in this electronic deliverable. Michco's only part in this electronic deliverable was the electronic assembly process. By providing this manual on line we are not guaranteeing parts availability.

You may contact Michco through the following methods:

Phone (517) 484-9312 or (800) 331-3339

2011 N. High St. -- Lansing, Michigan -- 48906

Fax: (517) 484-9836

Email: [CustServe@Michco.com](mailto:CustServe@Michco.com)

Web site: [www.Michco.Com](http://www.Michco.Com)

Parts Web site: [www.FloorMachineParts.Com](http://www.FloorMachineParts.Com)

Order Parts on Line at:

**[www.FloorMachineParts.Com](http://www.FloorMachineParts.Com)**

Directly to Parts & Service:

By Email: **[Shop@Michco.com](mailto:Shop@Michco.com)**

By Fax: (517) 702-2041

By Voice: Use numbers above.

**Serving the Cleaning Industry Since 1922**

Notice: All copyrighted material remains property of original owners, all trademarks are property of respective owners. Manuals are subject to Manufacturer's reproduction limitations. Originals or reproductions were provided by manufacturers through a request. We make no warranty as to the correctness of information provided in this document and you assume all risk. By placing these manuals on line we are not declaring our corporation to be an manufacturer authorized dealer or provider, please check our web site for authorized manufacturers we represent.

***Minuteman***<sup>®</sup>  
***Parker***<sup>®</sup>

**Arlington**

**Model: AS-8636**

**OPERATION**

**SERVICE**

**PARTS**

**CARE**

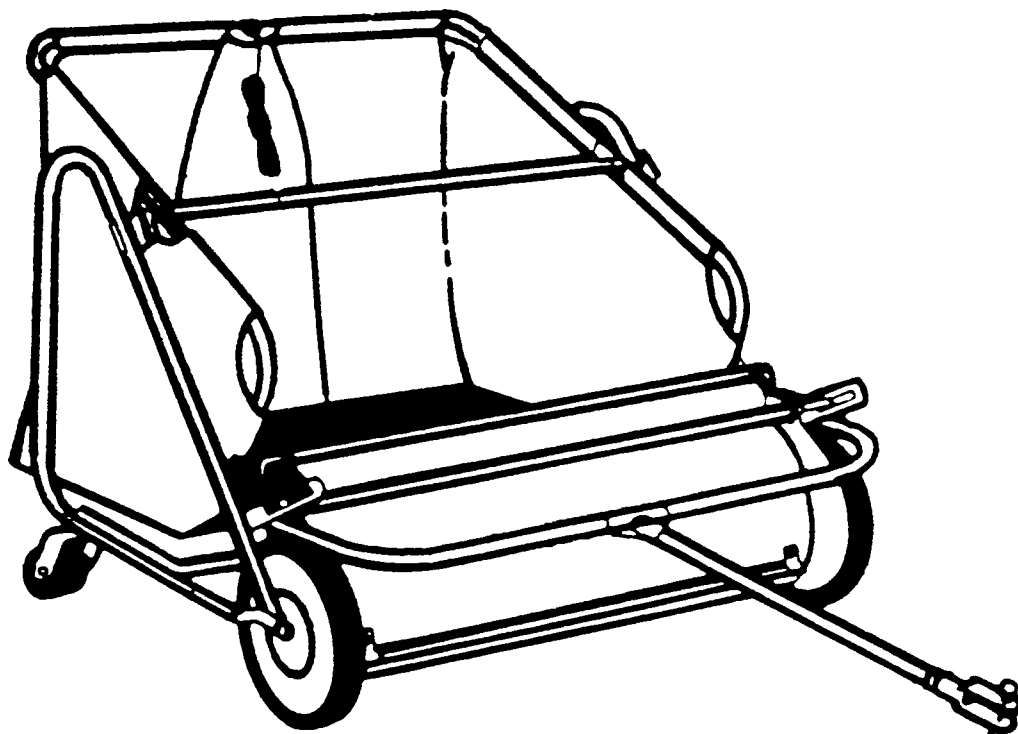

# ASSEMBLY INSTRUCTIONS

**YOUR SAFETY IS OUR CONCERN. READ ALL SAFETY RULES AND OPERATING INSTRUCTIONS BEFORE ATTEMPTING TO OPERATE THIS EQUIPMENT. FAILURE TO FOLLOW SAFETY RULES AND OPERATING INSTRUCTIONS MAY RESULT IN SERIOUS INJURY.**

The unit covered by this owner's guide is shipped complete in one carton and will take a minimum amount of time and effort to assemble. Follow all assembly instructions carefully. Whenever the terms left hand, right hand, or L.H., R.H. are used, it should be understood to mean from a position behind the unit in the direction of forward travel. All hardware is on the unit in its proper location. If something is missing, notify the dealer/distributor where unit was purchased. If unable to obtain parts locally, contact the Parker Sweeper Company.

## GENERAL INFORMATION

1. Remove the unit and hardware carton from the main carton. **Do Not** discard any inserts until unit is completely assembled.
2. The hardware carton contains the tubing for the frame assembly, the basket assembly and the pivot rod assembly for the basket.

NOTE: Identification of these parts will be determined in instructions at point of assembly.

3. Read through the owner's guide once to familiarize yourself with the assembly procedure, maintenance and operation of the unit.
4. Many times the exploded views at the back of this owner's guide can aid in the assembly of the unit.

## ASSEMBLING FRAME TO SWEEPER UNIT ASSEMBLY

NOTE: The numbers in parenthesis refer to those used in the adjoining AF-668, AF-637, AF-638 and exploded view for FRAME ASSEMBLY on plate number 1192 at the back of this owner's guide.

1. Remove two contour head bolts (28), lockwashers (32) and hex nuts (35) from the front sides of the frame support (5).
2. Align two holes in frame support (5) with the holes in the lower frame support (1) and reassemble contour head bolts, lockwashers and nuts. (See AF-668, right).
3. Remove two contour head bolts (28), lockwashers (32) and hex nuts (35) from the rear ends of the frame support (5). Also remove the hex head bolts (29), tube clamps (15) and locknuts (38) from the caster plates (16).
4. Remove the two rear frame support (3) from the hardware carton. Slide open end of rear frame support (3) over small diameter of lower frame support (1).
5. Align holes in rear ends of frame support (5) with the holes in the sides of rear frame support (3) and reassemble the contour head bolts, lockwashers and hex nuts removed in step 3. (See AF-668, right).
6. Remove the two hex head bolts (26) and hex lock nuts (36) used to secure caster assemblies to the hitch yoke (6).
7. Remove caster assemblies, special washers (19) and bearings (17) from yoke (6).
8. Reassemble the hex head bolts and lock nuts to yoke (6) as they will be used later to assemble hitch tongue.
9. Using the hardware removed from caster plates (16) in step 3, and hardware from step 7, assemble casters as follows:
  - A. Place hex head bolt (29) through tube clamp (15).
  - B. Assemble hex head bolt down through hole in rear frame support (3) and caster plate (16).
  - C. Place bearing (17) on bolt with large diameter against caster plate.
  - D. Place caster assembly on bolt with small diameter of bearing through hole in top of caster fork (18).
  - E. Place special washer (19) on bolt against small diameter of bearing and secure with hex lock nut (38). (See AF-637, right).

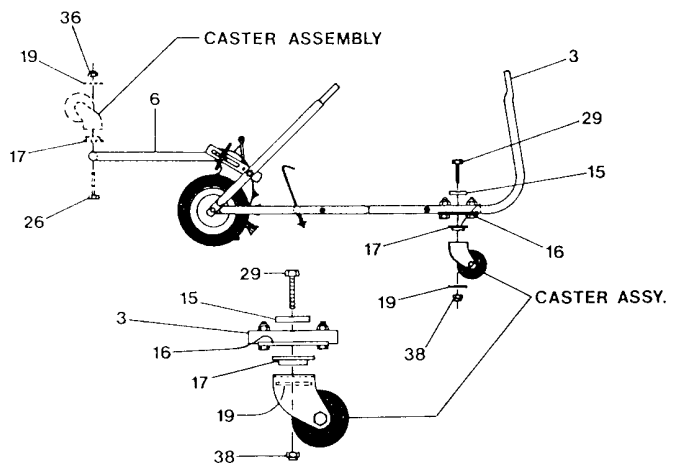
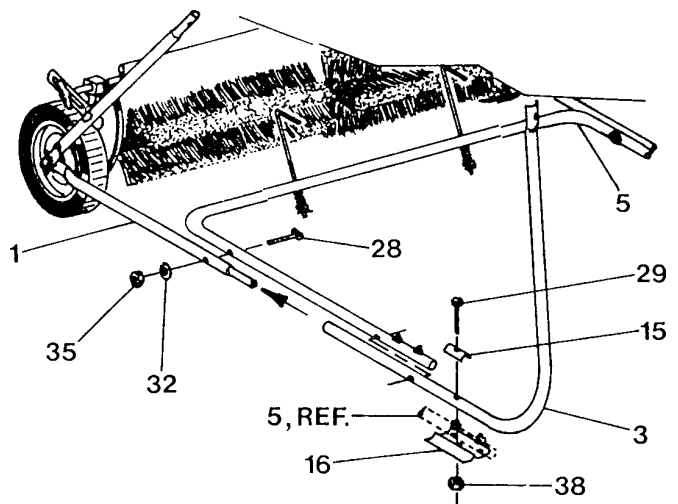

# ASSEMBLY INSTRUCTIONS

**NOTE: FAILURE TO OBSERVE SAFETY INSTRUCTIONS MAY RESULT IN SERIOUS INJURY.**

## ASSEMBLING FRAME TO SWEEPER UNIT ASSEMBLY (CONTINUED)

10. Remove the two upper frames (4) from the hardware carton.
11. When assembling the left and right hand upper frames (14) the pivot brackets must be to the inside of unit. (See AF-638, right).
12. Remove the contour head bolts (27), lockwashers (32) and hex nuts (35) from both ends of the upper frames.
13. With the pivot brackets (14) to the inside, slide front end of upper frame (4) over small diameter of lower frame (2). Place the back of upper frame in the curved end of rear frame support (3) and reassemble contour head bolts, lockwashers and nuts. (See AF-638, right)

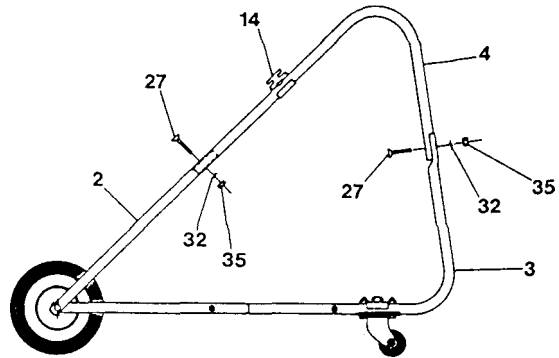

## ASSEMBLING BASKET

**NOTE:** The numbers in parenthesis refer to those used in the adjoining AF-639, AF-640, AF-641, AF-642 and exploded view for BASKET ASSEMBLY on plate number 1193 at the back of this owner's guide.

1. Lay the basket assembly on a flat surface and unfold back, and sides, leaving as much of the basket bottom uncovered as possible.
2. Remove the right (13) and left (17) hand lower basket frames from the hardware carton.
3. When the lower basket frames are in the proper location, the flattened ends are turned up and to the outside of basket. (See AF-639, right).
4. Remove the two front basket frames (14) from the hardware carton. Remove hex head bolt (16) and lockwasher (15) from front basket frames (14). Do not remove lockwashers (15) from bolts (16).
5. Place long end of front basket frames (14) through the lower loop in front of basket and slide basket onto tube until the flattened end will start through the front loop in bottom of basket (See AF-639, right).
6. Align hole in front basket frame (14) with hole in lower basket frame (17) L.H.
7. Place one bolt (16) through the front basket frame (14) and lower basket frame (17) L.H.
8. Pull basket clamp (18) up so basket bottom bends to contour of lower basket frame. Assemble bolt (16) into basket clamp (18). (See AF-640, right).

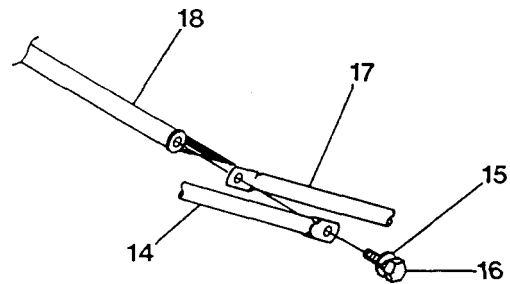
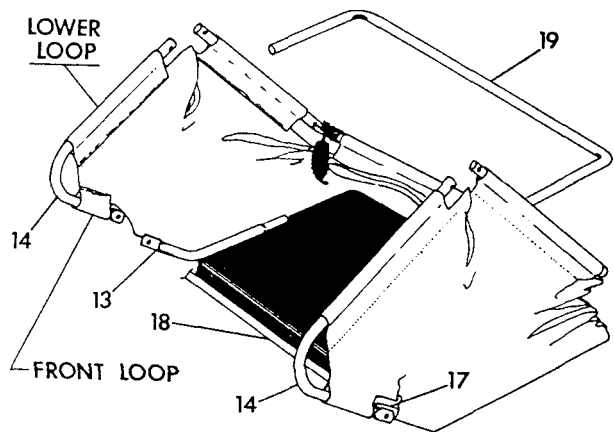

**NOTE:** Be careful to thread bolt straight into nylon insert, so threads of insert do not strip out. **DO NOT TIGHTEN.**

9. Repeat steps 6 through 8 for R.H. lower basket frame (13).
10. Place the lower basket frame back (19) down over small diameter ends of lower basket frames (13) and (17). Lift back of basket up and push lower basket frame back (19) down against bottom and back of basket.

**NOTE:** After lower basket frame back (19) is in place tighten bolt (16) on both sides of basket.

11. Remove the pivot rod assembly from the hardware carton.
12. Remove the four contour head bolts (6), lockwashers (7) and hex nuts (8) from the pivot brackets (12).
13. Place ends of rear basket frame (1) and front basket frames (14) between two pivot brackets (12) on each side of pivot rod (22).
14. Align holes in brackets (12) with those in frames (1 and 14) and reassemble contour head bolts (6), lockwashers (7) and nuts (8). (See AF-641, right)

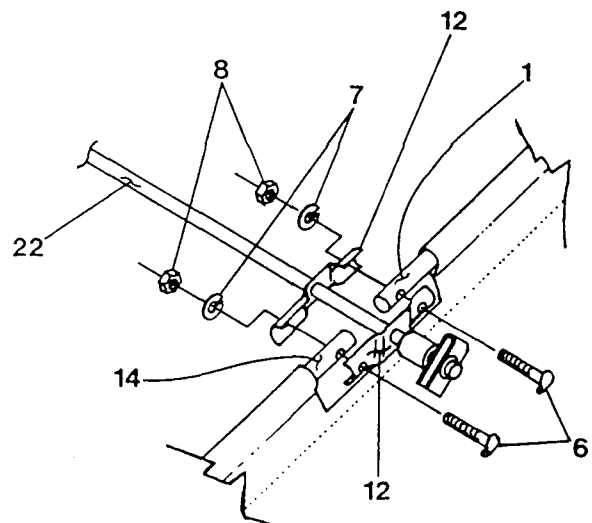

# ASSEMBLY INSTRUCTIONS

**SAFETY IS IMPORTANT! DO NOT IGNORE IT! OBSERVE IT! BE SAFE!**

## ASSEMBLING BASKET (CONTINUED)

15. Remove the rope clip (2) and rope (3) from the corner of the rear basket frame (1) and reattach clip (2) and rope (3) to center of frame (1). Rope must be to inside of basket.
16. Remove the basket spring (4) from the hardware carton.
17. Lift back of basket up and insert ends of spring (4) into holes in top of lower basket frame-back (19) while placing top of spring (4) against rear basket frame (1), underneath rope clip. (See AF-642, right).
18. Push rope clip (2) down to assist snapping the spring (4) into the notch on the under side of the rear basket frame (1).
19. With spring (4) in place, push the rope clip (2) up to lock spring in position. If spring (4) is bowed to the inside of basket, push it back to lay against back of basket. (see AF-642, right).
20. Basket is now ready to assemble to sweeper unit and frame assembly.

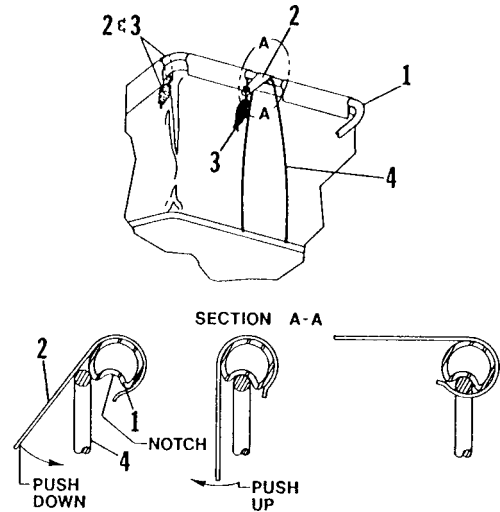

## ASSEMBLING BASKET TO UNIT

NOTE: The numbers in parenthesis refer to those used in the adjoining AF-645 and exploded view for basket assembly on plate number 1193 at the back of this owner's guide.

1. Place basket between the two upper frames with the basket opening toward the sweeper unit assembly.
2. With the pivot latches (10) upright, place pivot rod (22) in the TOP SLOT of pivot brackets. (See AF-645, right)

NOTE: The pivot latches (10) must straddle the pivot brackets (See AF-645, right).

3. Push the pivot latches (10) forward and down over the pivot brackets to lock basket in place.

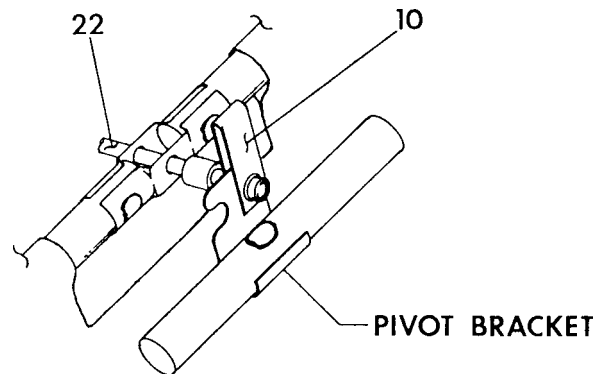

## ASSEMBLING HITCH TO YOKE

NOTE: The numbers in parenthesis refer to those used in the adjoining AF-643 and exploded view for frame assembly on plate number 1192 at the back of this owner's guide.

1. Remove hitch tongue (7) from hardware carton.
2. Remove the two hex head bolts (26) and hex lock nuts (36) from the hitch yoke (6).
3. Loosen hex head bolt (26) and locknut (36) used to assemble tee clamps (8) to hitch tongue (7). (See AF-643, right)
4. Open tee clamps (8) and place them around hitch yoke (6).
5. Align holes in tee clamps (8) with those in hitch yoke (6).
6. Reassemble hex head bolts (26) and lock nuts (36) removed in step 2, and tighten. Also tighten bolt and nut loosened in step 3. (See AF-643, right).

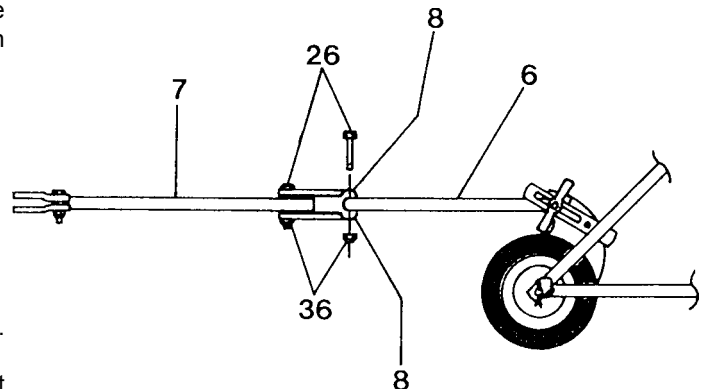

# OPERATING INSTRUCTIONS

## OPERATED SPEED

- A. Moving the sweeper forward rotates the brushes, propelling the leaves, clippings, etc. into basket.
- B. Select a forward travel speed that provides efficient sweeping without throwing debris over the back of basket.

# OPERATING INSTRUCTIONS

## READ SAFETY & OPERATING INSTRUCTIONS BEFORE OPERATING EQUIPMENT

### CAUTIONS

- A. The basket has been designed for holding a large capacity of dry grass clippings. When grass clippings are wet or freshly cut, caution should be exercised on the amount picked up. The basket could be overloaded and make dumping difficult.
- B. DANGER: Do not hold dumping rope in hand while towing. Secure loose end to tractor behind operator. Do not allow rope to contact brushes, as it may become tangled in reel shaft causing damage to the unit and possible injury to operator. (See AF-644, below).
- C. CAUTION! This sweeper is not designed to haul people, animals or equipment. Severe damage to the sweeper and possible injury to people or animals may result if this warning is ignored.
- D. NOTE: When basket is empty caution must be taken on rough (uneven) terrain. Travel slowly to prevent possible upsetting of the sweeper (tipping forward) when moving over gravel driveways, rutted turf, curb areas, bits of broken tree limbs, twigs, mole runs or other interferences. Traveling too fast over rough areas may cause the sweeper wheels to be blocked causing the sweeper to upset.

### BRUSH HEIGHT ADJUSTMENT

- A. To raise brushes to extreme height, loosen the large wing nut, pull sweeping unit forward as far as slots in brush adjustment brackets will permit. To lower brushes to lowest position push sweeping unit backwards as far as slots will permit. Secure wing nut when desired brush adjustment is obtained.
- B. For grass clippings or leaves, adjust brushes to highest position. After trial run on lawn, should the setting be too high, lower slightly and try again until correct setting is found. Brush life may be prolonged by adjusting so contact with ground is light. The lighter the contact, the longer the wear and ease in pulling.
- C. The most efficient operating height is when brushes just contact the top of the grass or make light contact with paved surfaces. When brushes are set too low, the sweeper will pull hard. This will lead to excessive brush wear and require premature brush replacement. Always have brushes in the raised position when transporting sweeper.
- D. REMEMBER: Brushes set too low may cause the sweeper handle to pivot forward striking tractor or operator, resulting in damage to tractor or injury to operator.
- E. NOTE: If the brushes do not rotate and the wheels slide when the sweeper is being pulled, the brushes are set too low.

### HOOD ADJUSTMENT

- A. The hood can be adjusted to change the deflection of the material being handled, by loosening the wing nuts in the lower corners of the hood and sliding the hood up or down.
- B. If sweeping at a high rate of speed the hood should be raised to deflect the material to the back of basket. If set too low the material could be thrown over the back of basket.
- C. If sweeping at a low rate of speed the hood should be set lower until material goes to the back of basket.

### DUMPING BASKET

- A. To load is dumped by pulling basket forward with rope, causing basket to pivot into a semi-inverted position. When load is discharged, allow rope and basket to return to its normal position.

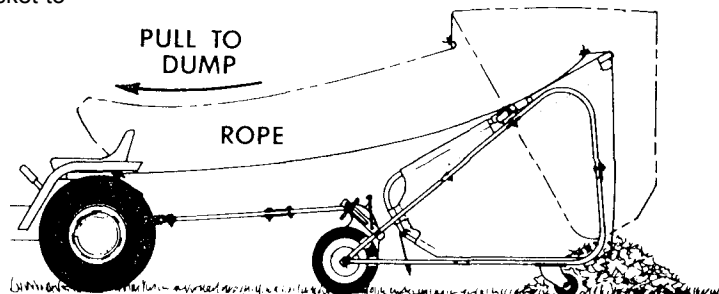

# OPERATING INSTRUCTIONS

OBSERVE SAFETY RULES AT ALL TIMES. DON'T TAKE CHANCES!

## SWEEPING TIPS

- A. Use sweeper in early spring to give your lawn a healthful cleaning.
- B. Use sweeper after mowing to remove turf clippings and give the lawn a blanket like effect.
- C. Sweep often in Fall as leaves are dropping. Do not wait until leaves are all off trees.
- D. For best sweeping results keep lawn cut short. When sweeping turf clippings do not overload basket. Turf clippings are heavy and overloading basket will put unnecessary stress on basket.
- E. To reduce the number of loads required when picking up leaves, it may be easier to mow over the leaf area at your normal mowing height before using the sweeper. The mowing will break up the leaves allowing them to compact when picked up with the sweeper. This may reduce your leaf loads to approximately one quarter the number required when picking up whole leaves.

## USING WIND APRON

The wind apron is furnished with the unit. This is used to keep the sweepings in the basket on windy days or when sweeping at a fast speed. The wind apron is stretched across the basket and tied on the frame as shown at the top corner and middle at the pivot bracket.

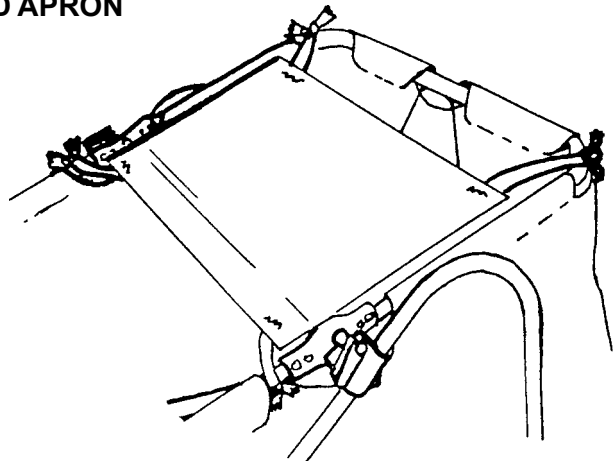

# MAINTENANCE INSTRUCTIONS

## LUBRICATION

- A. Occasionally lubrication of the sweeper will lengthen the service life.
- B. Place a few drops of oil in the oil holes located in the hub of each wheel.
- C. Place a few drops of oil in the swivel bearings and axle of the casters every time the machine is used.

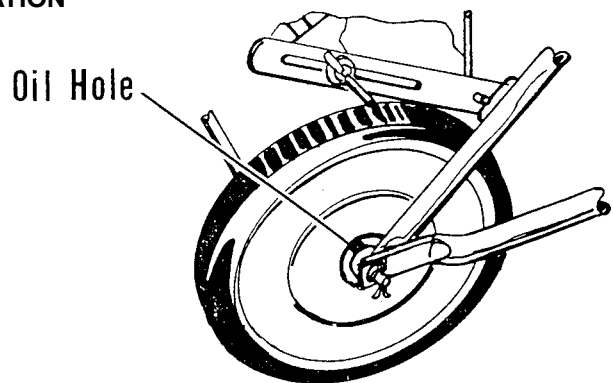

## CLEANING HOOD AND BASKET

- A. Wet grass clippings have a tendency to dry and adhere to the inner face of the hood; it is important to keep this face clean for good sweeping action.
- B. The basket should always be emptied immediately after each time the sweeper is used.
- C. If the grass or leaves being picked up are wet; wipe basket out with a soft cloth after dumping.
- D. Keeping the basket clean and dry will lengthen its service life.
- E. Clean hood and basket with warm soapy water, wipe dry with clean soft cloth.

# MAINTENANCE INSTRUCTIONS

READ SAFETY & OPERATING INSTRUCTIONS BEFORE OPERATING EQUIPMENT

## BRUSH CARE AND REPLACEMENT

### BRUSH REMOVAL

Should the bristles take a set from use, reverse the brushes on the reel shaft. Never allow the brush bristles to remain in a bent position on any object for any length of time as they can take a set.

- Turn the sweeper upside down on a workbench or the ground.
- Notice the brush stud has a collar fitting against one of the brush brackets holding it against the reel shaft.
- Remove the hex nuts and brush clamps from the end of the studs, on the sides with the collar.
- Remove the brushes from the brush bracket slots.
- Remove the hex nuts and brush clamps from the opposite end of the studs, but DO NOT remove the speed nut (this would allow the stud to fall out of reel shaft releasing the brush brackets).

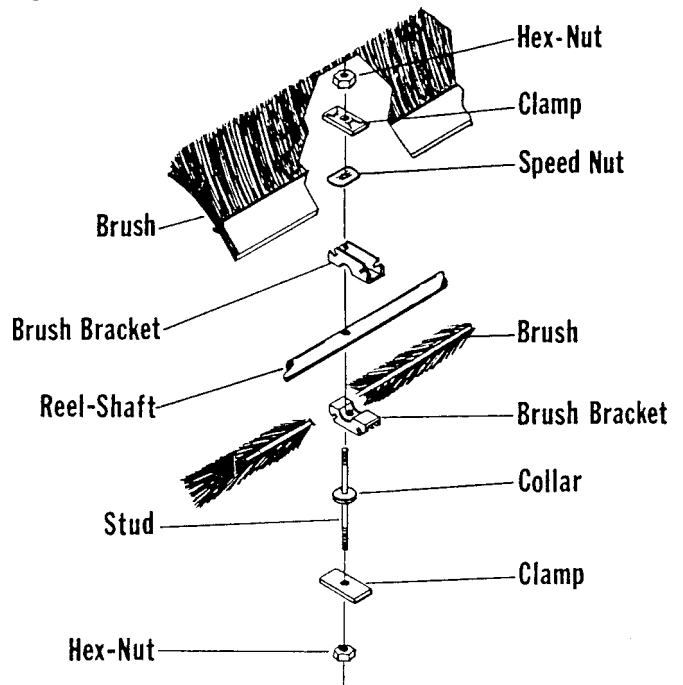

### TO REPLACE BRUSHES

- Turn the reel shaft to position the brush strips in the slots of the brush brackets that are held on the stud by the speed nut.
- Position the brush clamps and finger tighten hex nuts. Be sure brushes are all the way down in all the brush brackets.
- Brushes will be staggered with a slight overlap. Tighten lock nuts to assure brushes will be held firmly in place.
- Turn the reel shaft so the installed brush strips are on the bottom.
- Repeat the sequence of installation for the remaining four brushes.
- Tighten all nuts, torque to 50 to 55 inch pounds.

### STORAGE

- Clean basket to remove clippings and debris.
- Wipe dirt and grease from the chassis. Repaint scratched areas and coat metal parts with oil to prevent rust.
- Store sweeper in a dry area out of direct sunlight.
- Check sweeper parts for wear. Replace parts as necessary.
- Remove the basket assembly from the sweeper, release the basket spring and fold as shown.
- Remove the bolts, washers and nuts holding the upper and lower frames together, and fold as shown.
- The drawing shows the head assembly flat against a wall with the tongue tied to an anchor screw or nail in the wall. Tie a cord through the upper basket frame near the rope clip and hang it flat against the wall from an anchor screw or nail.

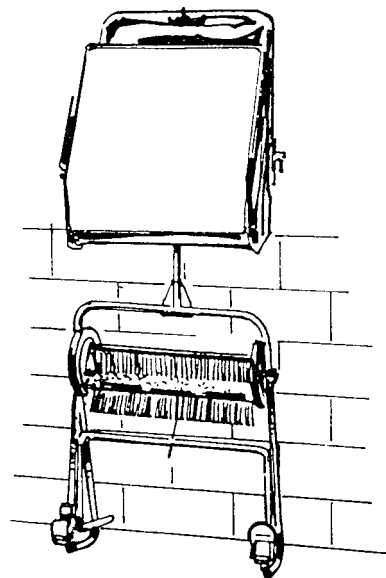

# HOW TO RE-INSTALL PINIONS

If for some reason you have found it necessary to remove the pinions, you should carefully follow these instructions. All parts must be clean before assembling.

1. To assist you, we suggest using a piece of wood doweling or plastic material 5/8" diameter, 2" long as shown. Each pinion is different as indicated by the part number and must be returned to the correct side of the shaft.
4. Pinion with part number 74-79 LB is to be replaced on the **left side** of the shaft. Part number 74-78 RB is for the right side. Line up the pinion (leaving the dowel in place) with the shaft as shown.

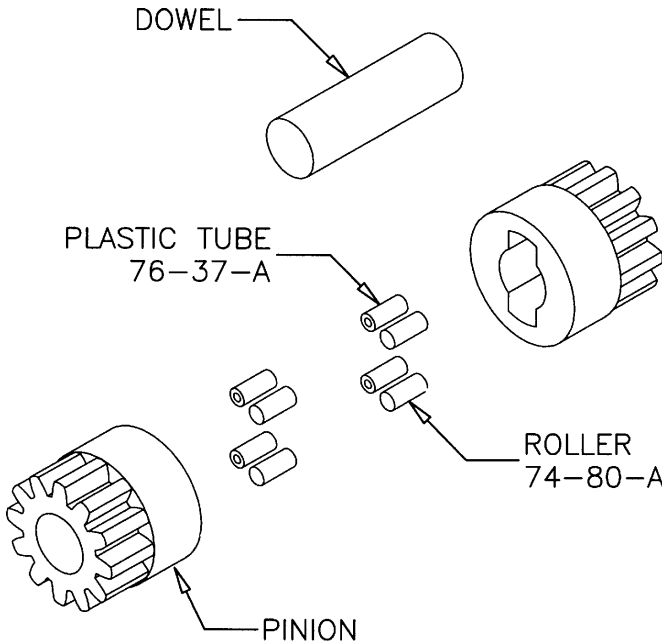

2. Insert the wooden dowel into the pinion.
3. Identify your pinion part number and insert the metal rollers. Place the plastic tubing in the cavity between the metal roller and the wall of the cavity. You may have to force the plastic tubing into this space but it is resilient and is supposed to fit tightly.

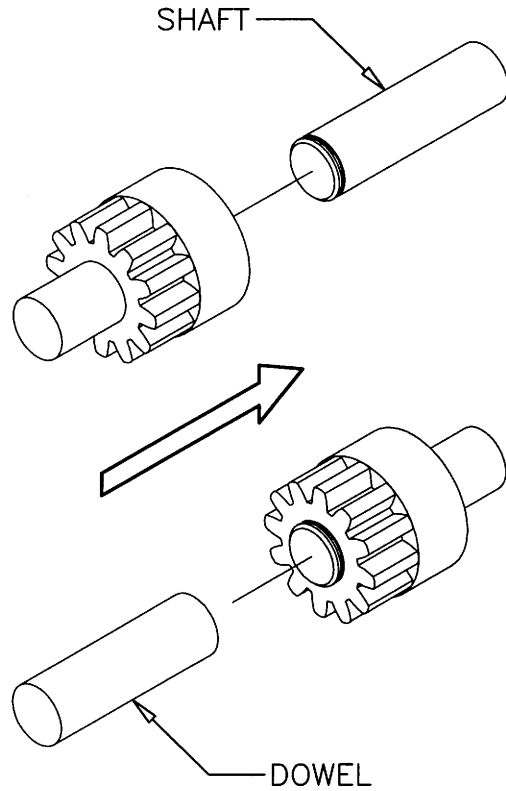

5. Push the pinion onto the shaft which will force the dowel to back out of the pinion. This will leave the rollers and plastic tubes in their proper position.
6. Apply a coating of grease on the outside of the wheel gear teeth. Do not grease inside pinions this will cause pawl springs to be ineffective.

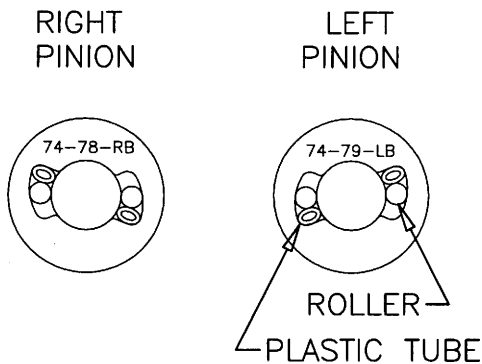

**NOTE!** The right and left side are determined from the operators position.

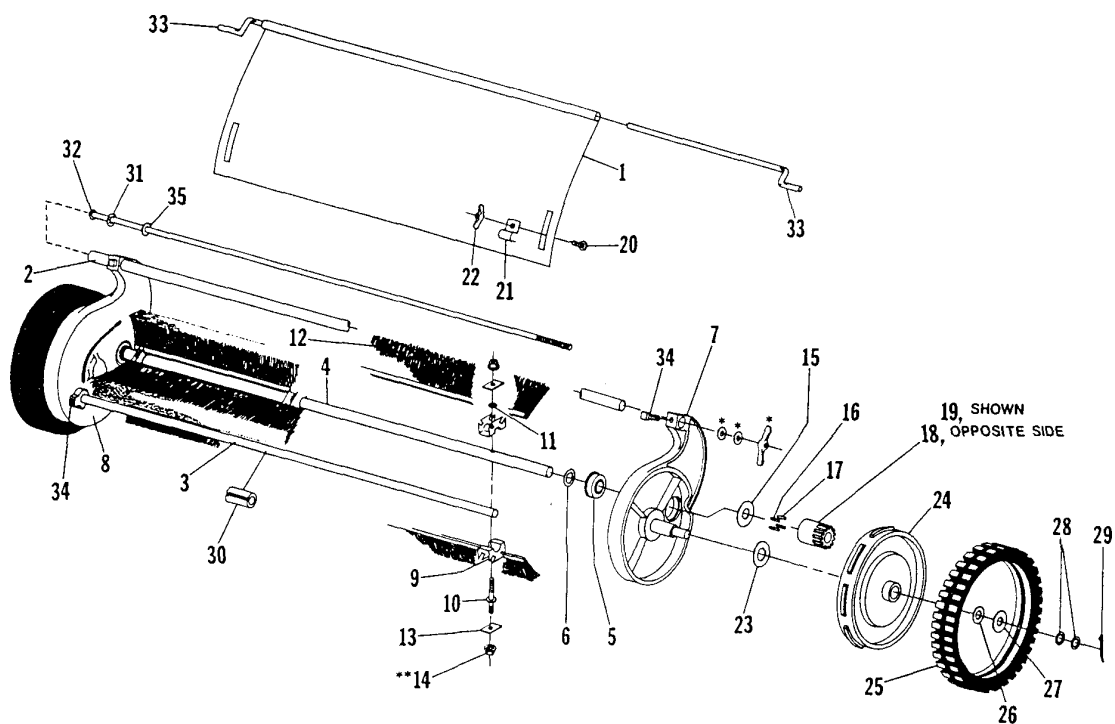

## PARTS LIST

Item	Part No.	Qty.	Description	Item	Part No.	Qty.	Description
1	84-247PTD	1	Painted Hood	19	74-79-LB	1	Pinion Left
2	83-163PLT	1	Adj. Tube Zinc Plated	20	70-416-8	2	Carriage Blot
3	68-33PLT	1	Tie Rod Zinc Plated	21	60-22-B	2	Hood Clamp Assembly Rec.
4	83-152-B	1	Reel Shaft Assembly	22	711364	2	Nut-Wing 1/4-20 STPL
5	68-60-A	2	Bearing	23	946-121624	2	Fiber Washer
6	55-161-A	2	WSR-Special	24	49-377PTD	2	Wheel Hub, Painted
7	71-05-LD	1	Side Plate Left	24A	SA-735-C	2	Tire Assembly
8	71-04-RD	1	Side Plate Right	25	78-124-C	2	Tire
9	74-13-C	8	Bracket	26	946-816-16	2	Fiber Washer
10	74-16PLT	4	Plated Stud Zinc	27	71-37-A	2	Washer Special
11	75-89-A	4	Speed Nut	28	46-81-A	4	Special Washer
12	1200-18-B	8	Brush Strip Assembly	29	380-764-16	2	Cotter Pin
13	69-04-A	8	Clamp Brush Strip	30	79-50-A	1	Rubber Spacer
14	711425	8	Nut-Flanged Wizz 1/4-20	31	711555	1	WSR-Lock 3/8 Internal
15	50-33-A	2	WSR-Special	32	83-164-A	1	Adj. Blt. Assembly
16	74-80-A	4	Pawl	33	84-248-A	2	Hood Control Rod
17	76-37-A	4	Pawl Spring	34	560C516-10	4	Square Head Set Screw
18	74-78-RB	1	Pinion Right	35	711506	1	WSR-Flat 5/16 ST PL

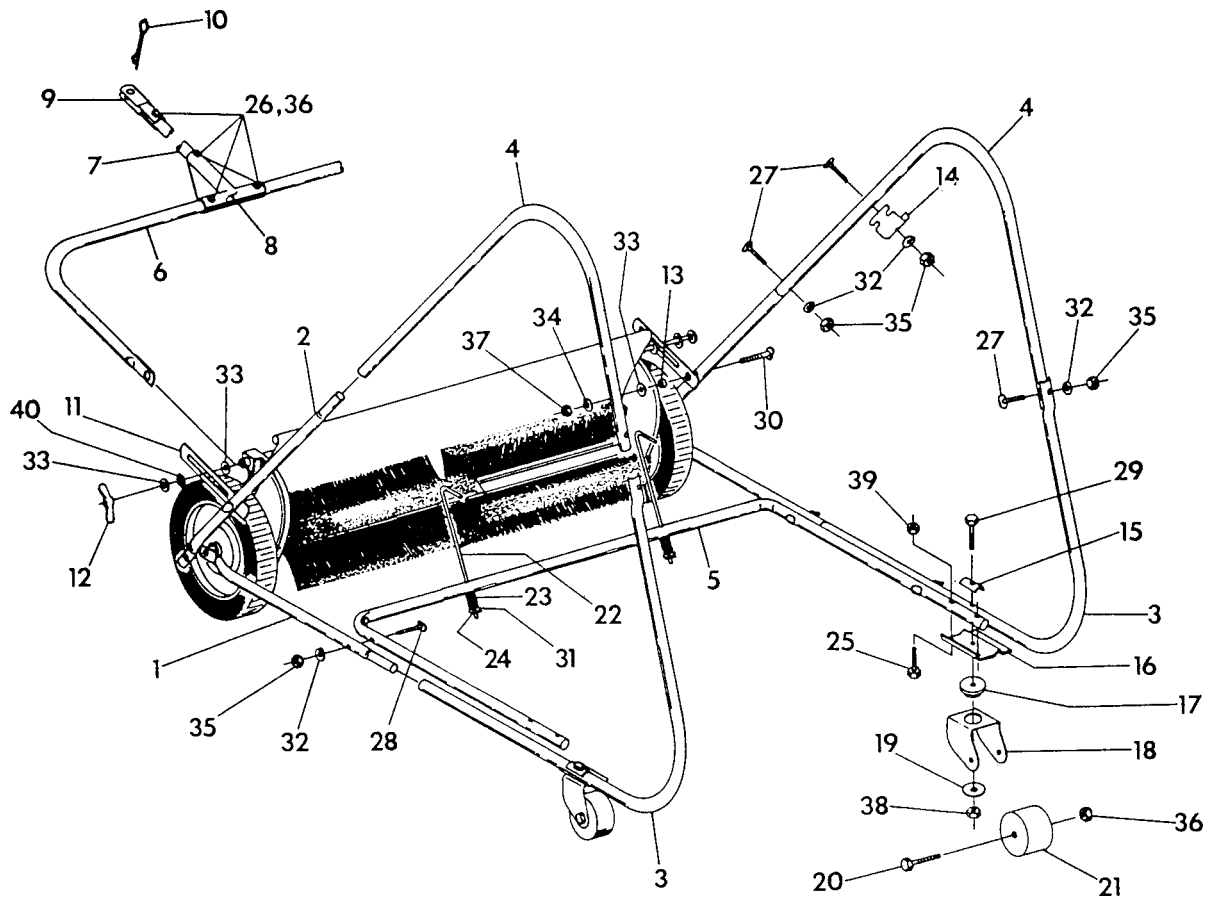

## PARTS LIST

Item	Part No.	Qty.	Description	Item	Part No.	Qty.	Description
1	86-38-C	2	Support, Lower	21	76-58-A	2	Roller
2	86-36-C	2	Frame, Lower	22	76-255-A	2	Basket Stop
3	86-40-D	2	Support, Upper	23	76-271-A	2	Spring
4	86-37-D	2	Frame, Upper	24	75-89-A	2	Speed Nut
5	83-161-B	1	Frame Support Assembly	25	713003	4	BLT-HH 1/4-20 x 1 #5
6	83-153-C	1	Yoke Hitch	26	713005	4	BLT-HH 1/4-20 x 1 1/2 #5
7	89-103	1	Tongue Weldment	27	69-416-20	6	BLT-Cont. Hd. 1/4-20 x 1.25
8	76-233-C	2	T Clamp	28	69-416-28	4	BLT-Cont. Hd. 1/4-20 x 1.75
9	89-103	2	Tongue Weldment	29	713031	2	BLT-HH 5/16-18 x 2 #5
10	81-14-A	1	Clinch Pin	30	69-516-24	2	BLT-Cont. Hd. 5/16 x 1 1/2
11	60-21-A	2	Bracket Brush	31	711505	2	WSR-Flat 1/4
12	73-71-A	1	Wing Nut	32	711544	10	WSR-Helical 1/4
13	54-227-A	2	Spacer	33	711506	4	WSR-Flat 5/16 ST PL
14	76-240-A	2	Bracket Pivot	34	711545	2	WSR-Helical 5/16
15	59-77-A	2	Clamp	35	711316	10	Nut-Hex 1/4-20 ST PL
16	76-81-B	2	Plate Caster	36	711373	6	Nut-Nyloc 1/4-20
17	78-130-A	2	Bearing	37	711319	2	Nut-Hex 5/16-18 ST PL
18	76-136-B	2	Caster Fork	38	711374	2	Nut-Nyloc 5/16-18
19	82-138-B-1	2	Special Washer	39	711377	4	Nut-Lock 1/4-20
20	76-202-A	2	Axle 3/8 D x 2.06	40	711565	1	WSR-External Lock 5/16

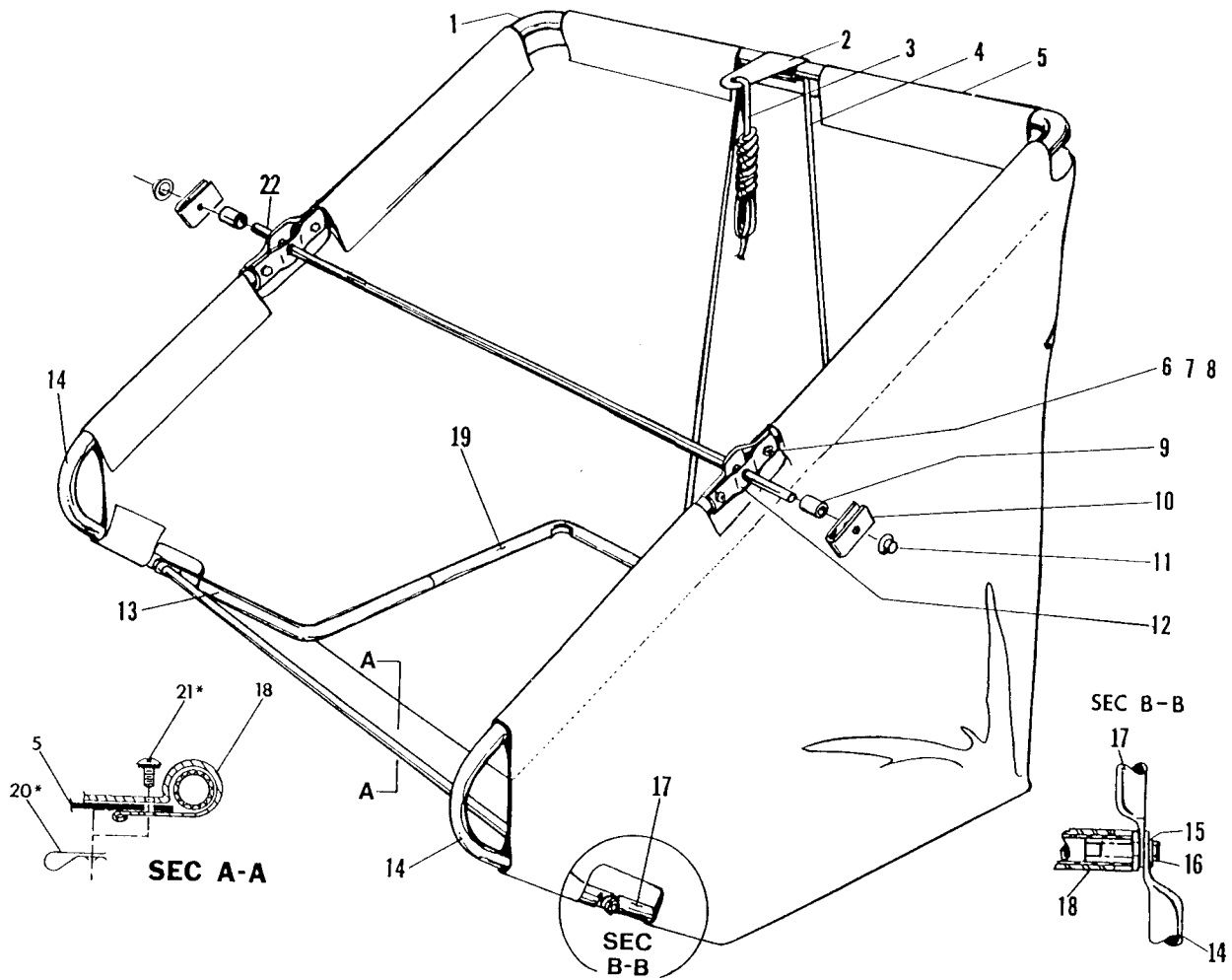

## PARTS LIST

Item	Part No.	Qty.	Description
1	83-154-B	1	Frame Basket Rear Assembly
2	76-252-A	1	Rope Clip
3	60-09-A	1	Rope Cut AS HS TE
4	83-33-B	1	Basket Spring
5	83-169-D	1	Basket Sub-Assy
6	69-416-24	4	BLT-Cont. Hd. 1/4-20 x 1.5
7	711554	4	WSR-Internal Lock 1/4 ID
8	711316	4	Nut-Hex 1/4-20 ST PL
9	73-414-A	2	Spacer Back Cover
10	76-242-A	2	Latch Pivot
11	130032	2	Cap Retainer
12	79-112-B	4	Pivot Bearing
14	76-295-B	2	Frame Basket Front
15	711545	2	WSR-Helical 5/16
16	713026	2	BLT-HH 5/16-18 x 3/4 #5
17	86-44-C	1	Frame Basket Lower
18	SA-1235-B	1	Basket Clamp R., AS-8636
22	83-155-A	1	Pivot Rod
23	83-165-B	1	Wind Apron Strap Assembly

# LIMITED WARRANTY

The Parker Sweeper Company warrants to the original purchaser/user that this product is free from defects in workmanship and materials under normal use and service for a period of three years from date of purchase. In addition, Parker Sweeper Company will, at its option, honor labor warranty claims for the first 12 months from date of sale, provided such claims are submitted through and approved by factory authorized repair stations. Parker Sweeper Company will, at its option, repair or replace without charge, except for transportation costs, parts that fail under normal use and service when operated and maintained in accordance with the applicable operation and instruction manuals.

This warranty does not apply to normal wear, or to items whose life is dependent on their use and care, such as belts, cords, switches, hoses, rubber parts, electrical motor components or adjustments. Parts not manufactured by Parker Sweeper Company such as engines, batteries, battery chargers, hydraulic pumps, and tires are covered by and subject to the warranties and/or guarantees of their manufacturers. Please contact Parker Sweeper Company for procedures in warranty claims against these manufacturers.

**Special warning to purchaser** — Use of replacement filters and/or prefilters not manufactured by Parker Sweeper Company or its designated licensees, will void all warranties expressed or implied.

A potential health hazard exists without exact original equipment replacement.

All warranted items become the sole property of Parker Sweeper Company or its original manufacturer, whichever the case may be.

Parker Sweeper Company disclaims any implied warranty, including the warranty of merchantability and the warranty of fitness for a particular purpose. Parker Sweeper Company assumes no responsibility for any special, incidental or consequential damages.

This limited warranty is applicable only in the U.S.A. and Canada, and is extended only to the original user/purchaser of this product. Customers outside the U.S.A. and Canada should contact their local distributor for export warranty policies. Parker Sweeper Company is not responsible for costs or repairs performed by persons other than those specifically authorized by Parker Sweeper Company. This warranty does not apply to damage from transportation, alterations by unauthorized persons, misuse or abuse of the equipment, use of non-compatible chemicals, or damage to property, or loss of income due to malfunctions of the product.

If a difficulty develops with this machine, you should contact the dealer from whom it was purchased.

This warranty gives you specific legal rights, and you may have other rights which vary from state to state. Some states do not allow the exclusion or limitation of special, incidental or consequential damages, or limitations on how long an implied warranty lasts, so the above exclusions and limitations may not apply to you.

***Minuteman***<sup>®</sup>  
***Parker***<sup>®</sup>

*A Minuteman International Company*

**World Headquarters**

Minuteman International, Inc.  
111 South Rohlwing Road  
Addison, Illinois 60101

Minuteman Canada, Inc.  
2210 Drew Road  
Mississauga, Ontario  
L5S 1B1

(630) 627-6900

FAX (630) 627-1130

(905) 673-3222

FAX (905) 673-5161

988381

Printed in U.S.A.