



## Electronic Service Manuals

This electronic document is provided as a service to our customers. We do not create the contents of the information contained in this document. Should you have detailed questions pertaining to the information contained in this document, you may contact Michco, or the manufacturer which provided the original information in this electronic deliverable. Michco's only part in this electronic deliverable was the electronic assembly process. By providing this manual on line we are not guaranteeing parts availability.

You may contact Michco through the following methods:

Phone (517) 484-9312 or (800) 331-3339

2011 N. High St. -- Lansing, Michigan -- 48906

Fax: (517) 484-9836

Email: [CustServe@Michco.com](mailto:CustServe@Michco.com)

Web site: [www.Michco.Com](http://www.Michco.Com)

Parts Web site: [www.FloorMachineParts.Com](http://www.FloorMachineParts.Com)

Order Parts on Line at:

**[www.FloorMachineParts.Com](http://www.FloorMachineParts.Com)**

Directly to Parts & Service:

By Email: **[Shop@Michco.com](mailto:Shop@Michco.com)**

By Fax: (517) 702-2041

By Voice: Use numbers above.

**Serving the Cleaning Industry Since 1922**

Notice: All copyrighted material remains property of original owners, all trademarks are property of respective owners. Manuals are subject to Manufacturer's reproduction limitations. Originals or reproductions were provided by manufacturers through a request. We make no warranty as to the correctness of information provided in this document and you assume all risk. By placing these manuals on line we are not declaring our corporation to be an manufacturer authorized dealer or provider, please check our web site for authorized manufacturers we represent.

# OWNER'S GUIDE



## VACUUM SWEEPER VAC-35 GASOLINE MODEL NO. PV-8808-K



AF-748

**READ THESE INSTRUCTIONS  
BEFORE SETTING UP AND OPERATING MACHINE**

**BE SAFE. PROTECT YOUR FAMILY, YOUR FRIENDS, YOURSELF.  
OBSERVE ALL SAFETY INSTRUCTIONS.**

**PARKER SWEEPER COMPANY**

**Box 1728**

**Springfield, Ohio 45501-1728**

Plate No. 1263

**87-94-A**

## TO THE OWNER

These instructions were written to assist you in the assembly and operation of your Vac-35. **READ THE INSTRUCTIONS** thoroughly **BEFORE** attempting to assemble and operate the machine so that you are familiar with the complete procedure and the safety precautions.

### RULES FOR SAFE OPERATION



The following safety precautions are suggested to prevent damage to the equipment or injury to the operator or nearby persons.

1. Do not allow anyone to operate the Vac-35 without proper instructions.
2. Do not permit children to operate the Vac-35.
3. Do not sweep too close to fire. Ingesting hot ashes or cigarette butts will ignite the bag.
4. Stop the engine before reaching into the intake housing or discharge chute to dislodge sticks or other debris.
5. Stop the engine before attempting to make any adjustment or performing any maintenance work on the Vac-35.
6. When working on the engine, always remove the spark plug wire from the engine and attach it to the V shaped clip on the engine head.
7. Do not run the engine in an enclosed area. Exhaust gases contain carbon monoxide, an odorless and deadly poison.
8. Do not fill the fuel tank while the engine is running. Spilling gasoline on a hot engine may cause a fire or an explosion.
9. While machine is running, do not leave it unattended.
10. Before using the machine to pick up debris, police the area to be cleaned first, picking up any large objects such as glass, toys, dog bones and chunks of wood. If these pass through the machine, they could damage the impeller, bend the engine crankshaft or put a hole in the bag.
11. Avoid using the machine in dangerous places where steep slopes or loose debris will endanger the safety of the operator or other people.
12. Keep all nuts, bolts and screws tight to be sure the Vac-35 is in safe working condition.
13. Follow the maintenance instructions as outlined in this manual.
14. Do not start or run engine unless bag and intake Housing are properly secured as injury may result.

### IMPORTANT

**ALWAYS GIVE THE FOLLOWING INFORMATION WHEN ORDERING REPAIR PARTS:**

- |                               |                        |
|-------------------------------|------------------------|
| 1. Part Number (Not Ref. No.) | 3. Description of Part |
| 2. Quantity Needed            | 4. Model No. of Vac-35 |

**If unable to obtain parts locally, write down above information and send to:  
PARKER SWEEPER CO., BOX 1728, SPRINGFIELD, OHIO 45501**

Your unit is right hand (R.H.) or left hand (L.H.) as you stand behind it.

# ASSEMBLY INSTRUCTIONS

**YOUR SAFETY IS OUR CONCERN. READ ALL SAFETY RULES AND OPERATING INSTRUCTIONS BEFORE ATTEMPTING TO OPERATE THIS EQUIPMENT. FAILURE TO FOLLOW SAFETY RULES AND OPERATING INSTRUCTIONS MAY RESULT IN SERIOUS INJURY.**

1. The VAC-35 covered in this owner's guide is shipped complete in one box. Follow all instructions on assembly very carefully.
2. Unpack Intake Housing, Spin-Pak®, Handle Assembly and Bag.
3. Tip box over so wheels are toward floor. Pull unit out of box and stand upright.
4. **DO NOT** discard the carton or any of the inserts until the unit is completely assembled.
5. All hardware is on the unit in it's proper location. If something is missing, notify the dealer/distributor where unit was purchased. If unable to purchase parts locally, contact the Parker Sweeper Company.
6. Whenever the terms left or right hand, or "L" and "R" are used, it means from a position standing behind the unit facing forward.

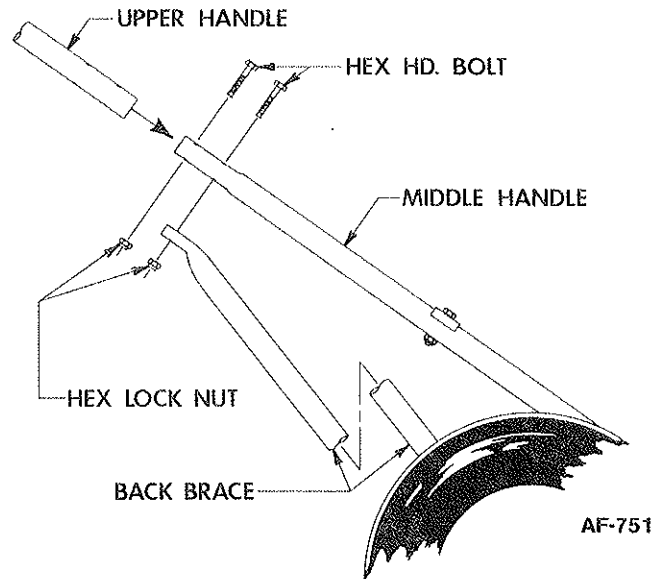

NOTE: Nuts should be tightened enough that at least two of the Bolt threads extend through the Nut. It may be necessary to collapse the tubing SLIGHTLY to accomplish this.

## HANDLE ASSEMBLY

NOTE: See AF-747 Handle Assembly on Plate No. 1268 to the back of this owner's guide for reference to numbers used in the following instructions.

1. Remove Hex Hd. Bolts (18) and Hex Lock Nuts (25) from the bottoms of the Upper Handles (3) and (4).
2. Place Upper Handles (3) and (4) over the ends of the Middle Handles (5).
3. Align the lower holes in both Upper and Middle Handles. Replace Hex Hd. Bolts (18), removed in step 1, to each of the lower holes.
4. Lift Handles until the Back Braces (6) can be assembled to Bolts (18) assembled in step 3. Assemble Hex Lock Nuts (25). **DO NOT TIGHTEN.**
5. Align the upper holes in both Upper and Middle Handles. Assemble the remaining two Hex Hd. Bolts (18) and Hex Lock Nuts (25). **DO NOT TIGHTEN.**

NOTE: Check Alignment of Handle. The Hex Lock Nuts have been left loose to allow movement between the holes and the Bolts. Do not bend tubing to accomplish proper alignment.

6. Once Handles are aligned tighten all Hex Lock Nuts (25).

## THROTTLE HOOKUP

1. To install the throttle control, remove it from the lower right hand handle.
2. Straighten the throttle cable out and run it up the left hand handle.
3. Attach the throttle control to the upper left hand handle with the two oval head screws and hex nuts furnished.
4. Make sure no bends are less than 8" radius.

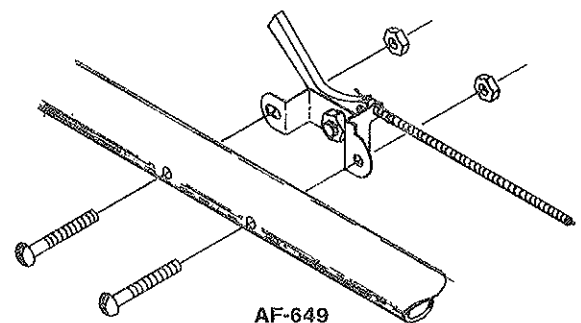

## TO ASSEMBLE SPIN-PAK®

NOTE: See AF-746 Housing Assembly on Plate No. 1270 to the back of this owner's guide for reference to numbers used in the following instructions.

**OBSERVE SAFETY RULES AT ALL TIMES. DON'T TAKE CHANCES!**

## ASSEMBLY INSTRUCTIONS (Cont.)

1. Remove Hex Hd. Bolts (30), Flatwashers (28), and Lock Nuts (42) from the three upper holes used to secure Retaining Ring (41) to Housing Assembly (1). DO NOT remove the bottom Bolt (30) or Retaining Ring (41) from Housing Assembly (1).
2. Align the holes in Spin-Pak® (2) with three upper holes in Retaining Ring (41) and Housing Assembly (1).
3. Replace hardware removed in step 1 and tighten.

### ATTACHING INTAKE HOUSING

1. Insert Hinge Bosses, on Collar (21) of Intake Housing (20) behind the Hinge Extension on Front Cover Assembly (7).
2. Swing Intake Housing (20) to lay flat against Front Cover Assembly (7).
3. Secure by placing Flatwasher (9) and Adjusting Knob (8), on Pivot Bolt, over the Collar (21) of Intake Housing (20) and tighten Adjusting Knob (8).

### ATTACHING DUST BAG

NOTE: See AF-747 Handle Assembly on Plate No. 1268 to the back of this owner's guide for reference to numbers used in the following instructions.

1. Loop Top Bag Straps over Upper Handles (3) and (4).
2. Slip Neck of Dust Bag (1) over Spin-Pak® until Tie Strap can be pulled tight around the Housing Neck, just over the bead on Spin-Pak®. Bead must be covered.

3. Attach Bag Hooks to front Lower Cross Brace (8).  
**IMPORTANT:** Failure to attach front Bag Straps to Lower Cross Brace will cause premature wear of Bag around the bottom and around neck at the Spin-Pak®. The Spin-Pak® may also break due to excessive weight from Bag.

### IMPORTANT

**WARNING:** The engine contains NO OIL. Read the Engine Instruction Manual carefully before operating the VAC-35. Be sure you know how to start and stop the engine before proceeding further. Do not start the engine until all assembly is finished.

### WARNING

Make a thorough inspection to see that all fastenings are tight and all parts are properly installed. DO NOT start Engine without Intake Housing and Dust Bag in place.

If Engine is started without Intake Housing attached, serious injury may result by drawing clothing or parts of the body into the Fan.

If Engine is run without Spin-Pak® or Dust Bag, small stones or other objects may be picked up and propelled at operator or bystanders through the unprotected opening causing serious injury.

**OBSERVE SAFETY RULES AT ALL TIMES. DON'T TAKE CHANCES!**

# OPERATING INSTRUCTIONS

## READ SAFETY & OPERATING INSTRUCTIONS BEFORE OPERATING EQUIPMENT

### TO START UNIT

**IMPORTANT:** Read the Engine manual CAREFULLY before operating the VAC-35.

Before starting the engine read and understand the following:

1. Be sure the engine crankcase is filled with the proper type and amount of oil.
2. Spin-Pak® is in place.
3. Dust Bag or Discharge Hose is in place.
4. Intake Housing or Hose Kit is attached to the Fan Housing.

### SERVICING AND OPERATING INSTRUCTIONS.

Refer to Engine Manufacturer's Service Manual. Careful attention to care of air cleaner and crankcase lubrication instructions will insure longer engine life.

KEEP ENGINE CLEAN.

### LUBRICATION

**NOTE:** See AF-746 Housing Assembly on Plate No. 1270 to the back of this owner's guide for reference to numbers used in the following instructions.

1. Oil the Dual Caster Wheel Assembly where Axle Support Weldment (13) assembles to Pivot Pin (12). Also oil Axle Weldments (15) where they assemble through Axle Support Weldment (13).
2. Add a few drops of oil to the Throttle Control Cable and Wire to help keep it operating smoothly.
3. Grease fittings are located in the hubs of the rear wheels. Fresh grease should be added periodically to assure proper lubrication of Wheels.

**NOTE:** Check all items once a week if unit is used daily.

### DUST BAG CARE

1. Keep the Dust Bag clean at all times.
2. The efficiency of this unit depends on the breathing capacity of the Dust Bag. Under extremely dusty conditions the bag should be emptied and cleaned frequently. Always empty and clean bag before storing after use. Debris allowed to remain in the bag may cause spontaneous combustion, resulting in an explosion or fire.
3. Heavy concentration of sand and gravel should be avoided. These materials are extremely abrasive, and while the VAC-35 will handle moderate amounts of these materials, it is not designed for heavy applications. Treat your VAC-35 with reasonable care and it will repay you with long, trouble-free service.
4. The VAC-35 will handle most common kinds of debris found around industrial plants, commercial buildings, homes and farms. Acid contaminated materials, magnesium, dust and other DANGEROUS DEBRIS that is considered hazardous should not be handled with the VAC-35 unless approved by a regulating authority considered to be an expert in the handling of such hazardous materials.

**DANGER:** Improper use of this equipment may result in serious injury.

When using hose attachment, keep it away from engine exhaust system and other parts of the engine that may be hot enough to burn plastic hose.

The VAC-35 is equipped with a front adjustable caster which provides any height adjustment of intake housing that is practical. Nuts must be kept tight.

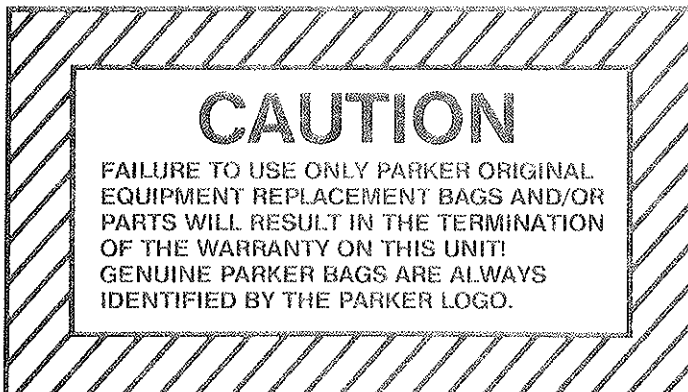

**SAFETY IS IMPORTANT!  
DO NOT IGNORE IT — OBSERVE IT!  
BE SAFE!**

**NOTE: FAILURE TO OBSERVE SAFETY INSTRUCTIONS MAY RESULT IN SERIOUS INJURY.**

ENGINE ASSEMBLY

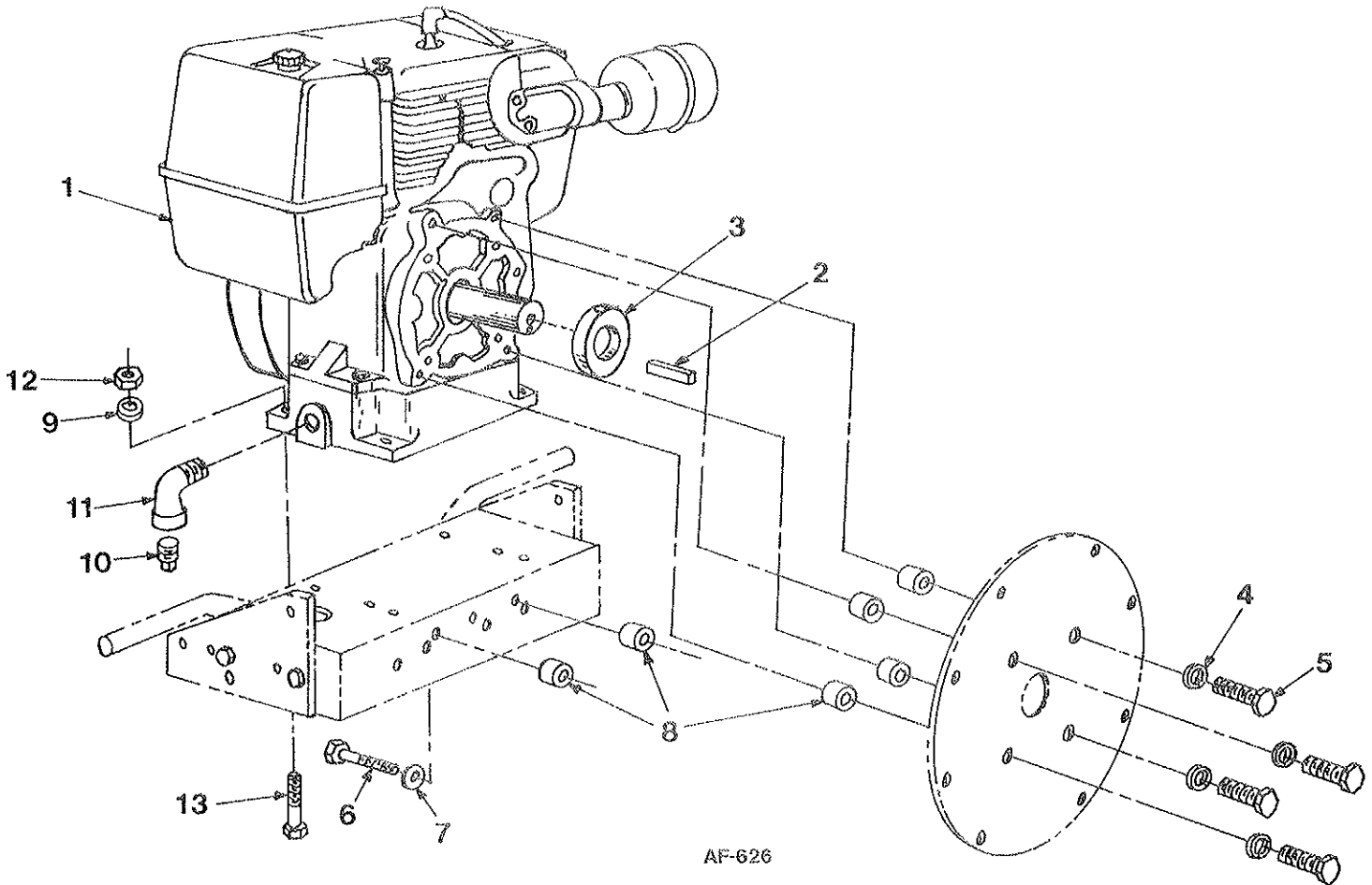

AF-626

PARTS LIST

Ref. No.	Part No.	Qty. Per Unit	Description
1	**	1	Engine, Kohler 8 H.P.
2	63-130-A	1	Fan Key, 1/4 Sq. x 1 3/4
3	72-179-A	1	Fan Spacer
*** 4	935-616	4	Lockwasher, Spring 3/8
*** 5	65-616-24	4	Bolt, Hex Hd. 3/8-16 x 1 1/2
*** 6	65-416-28	2	Bolt, Hex Hd. 1/4-20 x 1 3/4
*** 7	935-416	2	Lockwasher, Spring 1/4
8	79-139-A	6	Spacer
*** 9	945-616	4	Flatwasher, Plain 3/8
10	*	1	Pipe Plug, Oil Drain
11	57-81-A	1	Street Elbow, 1/2 x 90°
***12	365-616	4	Nut, Hex Lock 3/8-16
***13	65-616-20	4	Bolt, Hex Hd. 3/8-16 x 1 1/4

\*Supplied with engine

\*\*Koler Model No. M8T

\*\*\*Items should be purchased through a local hardware store.

# HOUSING ASSEMBLY

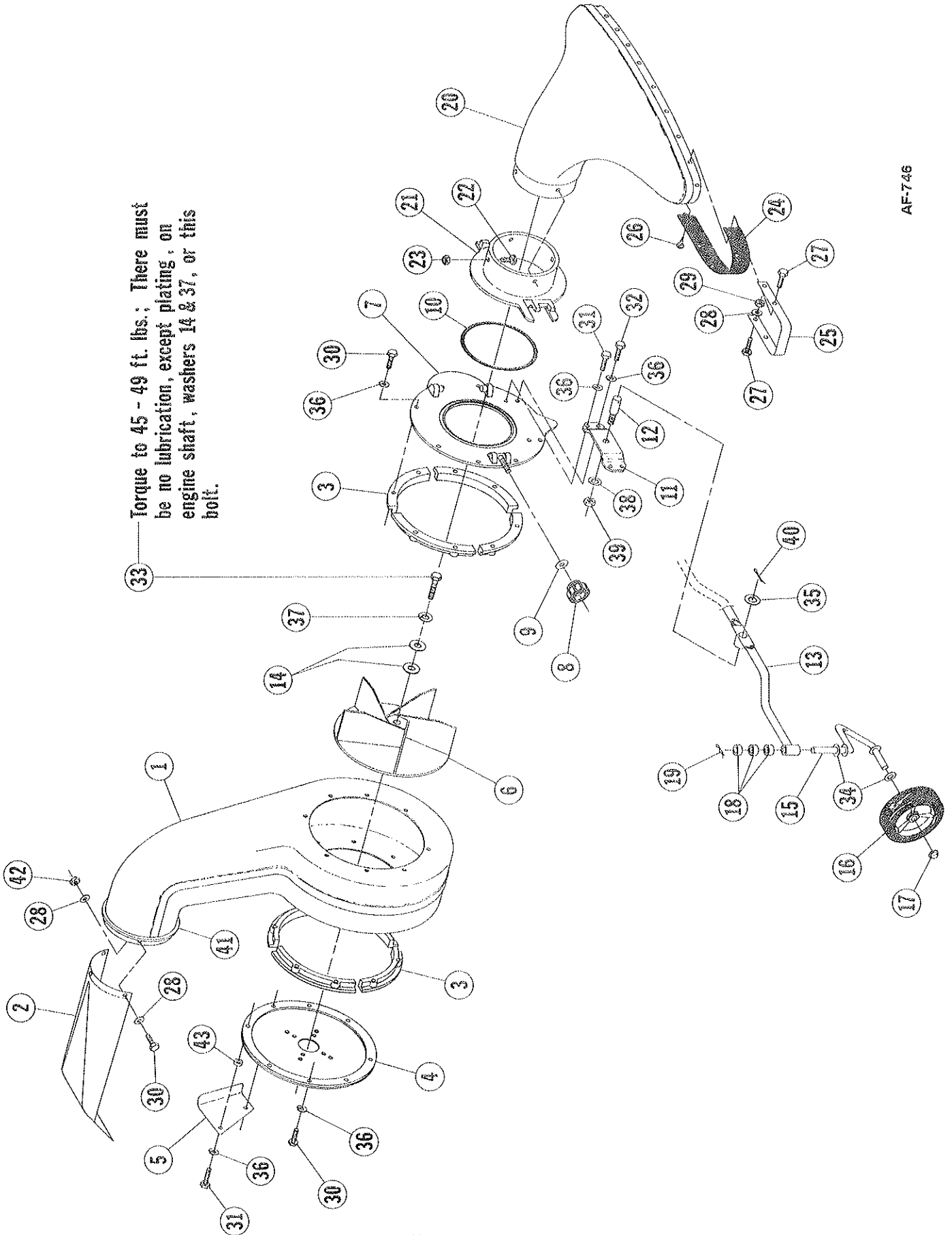

33—Torque to 45 - 49 ft. lbs.; There must be no lubrication, except plating, on engine shaft, washers 14 & 37, or this bolt.

AF-746

## HOUSING ASSEMBLY

## PARTS LIST

Ref. No.	Part No.	Qty. Per Unit	Description
1	70-103-D	1	Housing Assembly
2	85-110-B	1	Spin-Pak®
3	64-78-C	8	Anti-Wrap Segment
4	84-346-C	1	Back Plate & Gasket
5	72-241-B	1	Heat Shield
6	72-175-D	1	Fan Wheel
7	SA-1389-D	1	Front Cover Assembly
* 8	80-29-A	1	* Adjusting Knob
* 9	945-816	1	* Flatwasher, Plain 1/2
*10	63-190-A	1	* O-Ring Gasket
11	73-89-B	1	Mount Plate
12	73-94-A	1	Pivot Pin
13	83-211-B	1	Axle Support Weldment
14	82-138-B-3	2	Special Washer
15	86-108-B	2	Axle Weldment
16	84-300-C	2	Wheel
17	76-254-A	2	End Cap
18	79-16-A	6	Spacer
19	81-106-A	2	Cotter Pin
20	MA-251-D	1	30" Intake Housing Assembly

Items listed below should be purchased through a local hardware store except items 24, 25, 26, 33, 41, and 43.

**21	63-195-D	1	Collar
**22	65-416-10	4	Bolt, Hex Hd. 1/4-20 x 5/8
**23	369-416	4	Nut, Serrated Hex Lock 1/4-20
**24	73-67-D	1	Skirt
**25	62-98-C	2	Guard
**26	80-332-A	15	Fastener
**27	65-416-12	8	Bolt, Hex Hd. 1/4-20 x 3/4
**28	945-416	16	Flatwasher, Plain 1/4
**29	364-416	8	Nut, Hex Lock (thin) 1/4-20
30	65-416-16	14	Bolt, Hex Hd. 1/4-20 x 1
31	65-416-20	4	Bolt, Hex Hd. 1/4-20 x 1 1/4
32	65-416-24	2	Bolt, Hex Hd. 1/4-20 x 1 1/2
***33	60-716-16	1	Bolt, Hex Hd. 7/16-20 x 1
34	945-816	4	Flatwasher, Plain 1/2
35	945-1216	1	Flatwasher, Plain 3/4
36	935-416	16	Lockwasher, Spring 1/4
37	935-716	1	Lockwasher, Spring 7/16
38	936-816	1	Lockwasher, Int. Tooth 1/2
39	345-816	1	Nut, Hex Jam 1/2-20
40	380-532-20	1	Cotter Pin 5/32 x 1 1/4
41	85-59-C	1	Retaining Ring
42	365-416	4	Nut, Hex Lock 1/4-20
43	54-227-A	2	Spacer

\*Items 8, 9, & 10 are supplied with Item 7, but may be purchased separately.

\*\*Items 21-29 are supplied with Item 20, but Items 24, 25 & 26 may be purchased separately.

\*\*\*Item 33, Torque to 45 to 49 ft. lbs.

# HANDLE ASSEMBLY

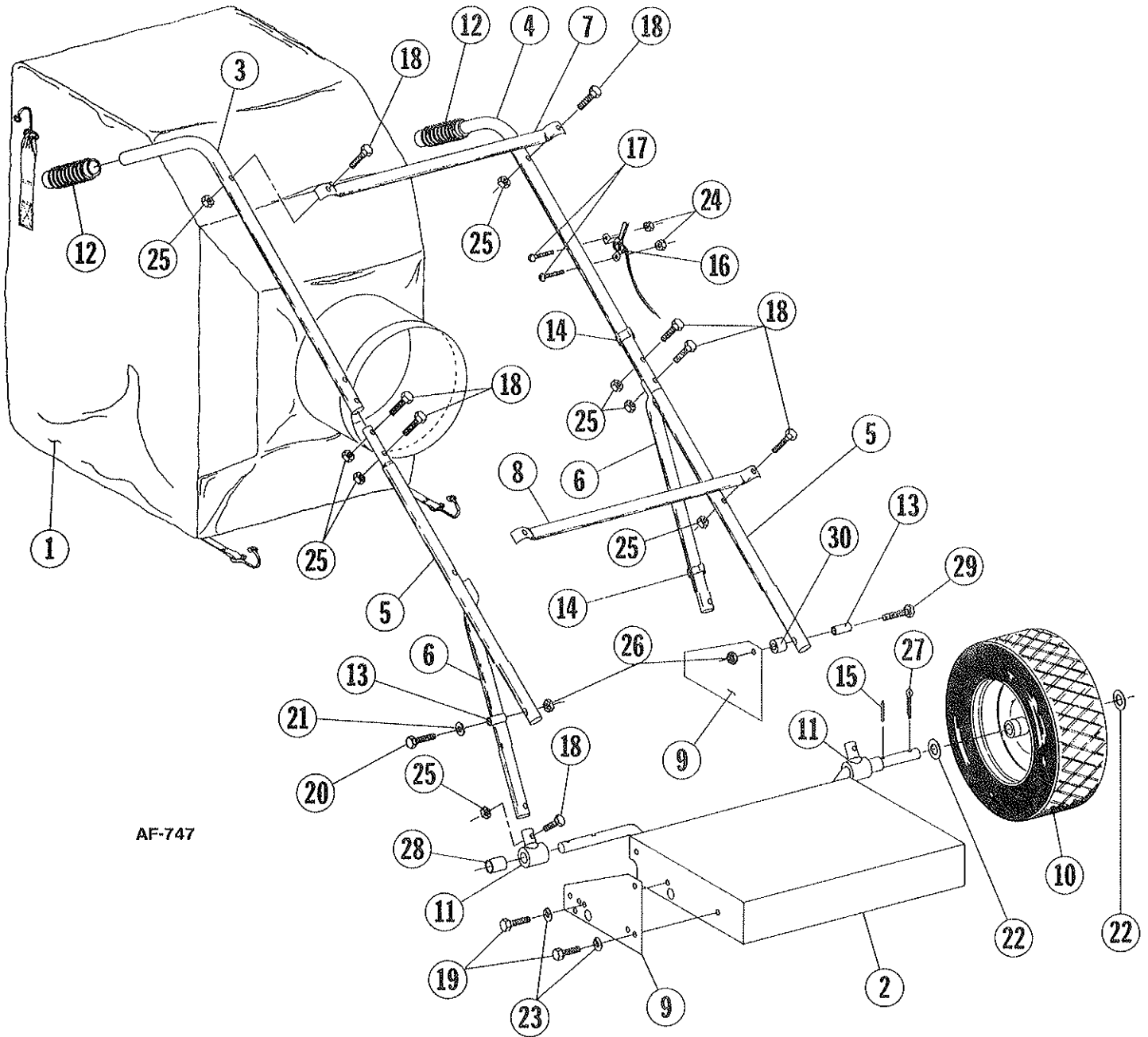

AF-747

## HANDLE ASSEMBLY

## PARTS LIST

Ref. No.	Part No.	Qty. Per Unit	Description
1	MA-585	1	Dust Bag Assembly
2	83-138-C	1	Chassis Weldment
3	80-321-C	1	Upper Handle R.H.
4	83-18-C	1	Upper Handle L.H.
5	82-245-B	2	Middle Handle
6	85-45-C	2	Back Brace
7	81-04-B	1	Cross Brace, Upper
8	81-58-B	1	Cross Brace, Lower
9	73-362-C	2	Handle Bracket
10	SA-231-B	2	Wheel Assembly
11	85-44-B	2	Handle Back Brace Adaptor
12	80-232-A	2	Handle Grip
13	80-238-A	2	Insert
14	80-276-A	2	Clamp, Snap-on
15	84-103-A	2	Roll Pin .199/.194 Dia. x 1 1/2 Lg.
16	83-25-B-44	1	Throttle Control Assembly
*17	515-10-20	2	Screw, Rd. Hd. Mach. 10-24 x 1 1/4
*18	65-416-24	10	Bolt, Hex Hd. 1/4-20 x 1 1/2
*19	65-516-12	4	Bolt, Hex Hd. 5/16-18 x 3/4
*20	65-516-28	1	Bolt, Hex Hd. 5/16-18 x 1 3/4
*21	945-516	1	Flatwasher, Plain 5/16
*22	945-1216	4	Flatwasher, Plain 3/4
*23	935-516	4	Lockwasher, Spring 5/16
*24	365-10	2	Nut, Hex Lock 10-24
*25	365-416	10	Nut, Hex Lock 1/4-20
*26	365-516	2	Nut, Hex Lock 5/16-18
*27	380-432-20	2	Cotter Pin
28	85-89-A	2	Spacer
*29	65-516-32	1	Bolt, Hex Hd. 5/16-18 x 2
30	83-181-A	1	Spacer

\*These Items should be purchased through a local hardware store.

# HOUSING ASSEMBLY

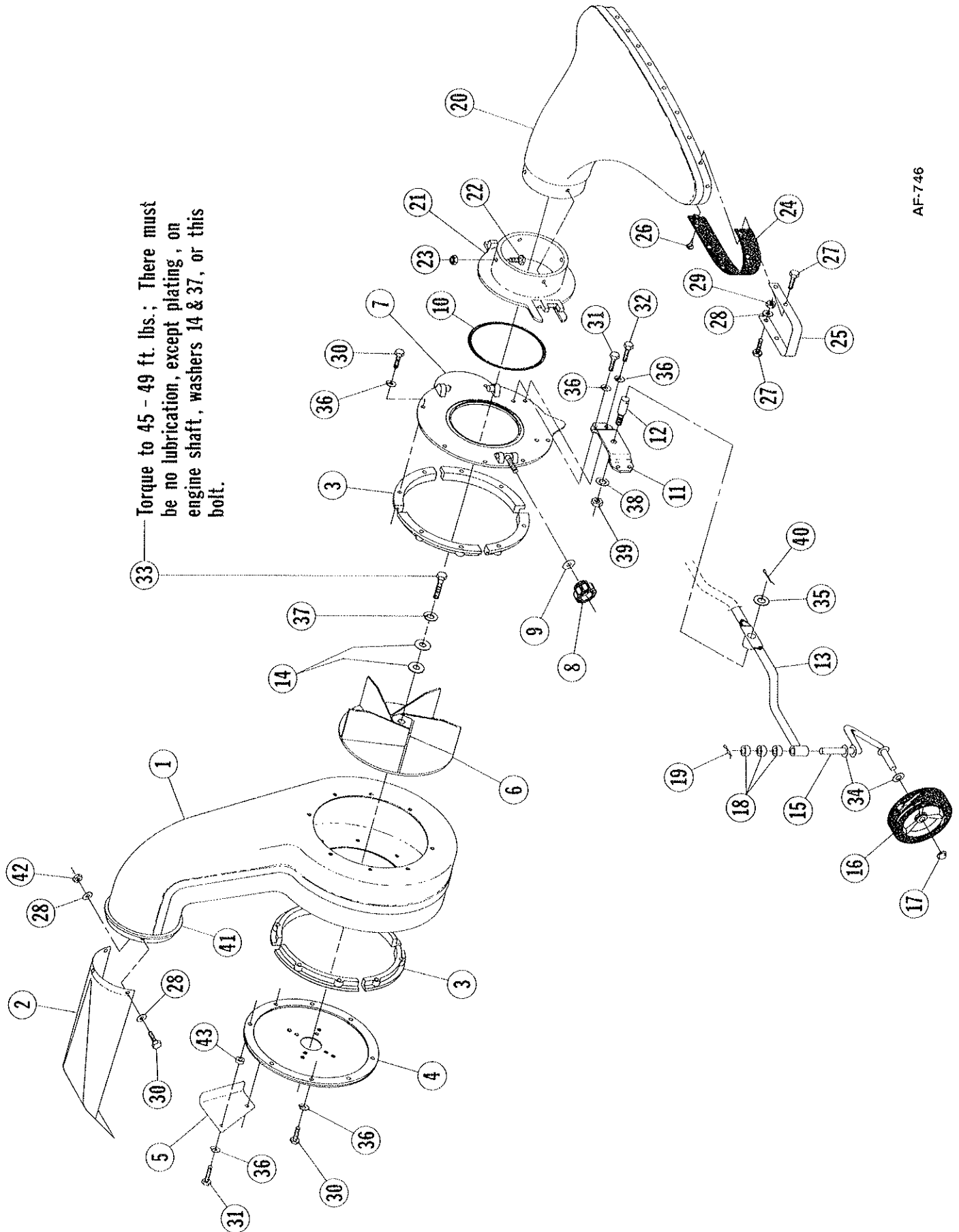

33 — Torque to 45 - 49 ft. lbs.; There must be no lubrication, except plating, on engine shaft, washers 14 & 37, or this bolt.

AF-746



# HANDLE ASSEMBLY

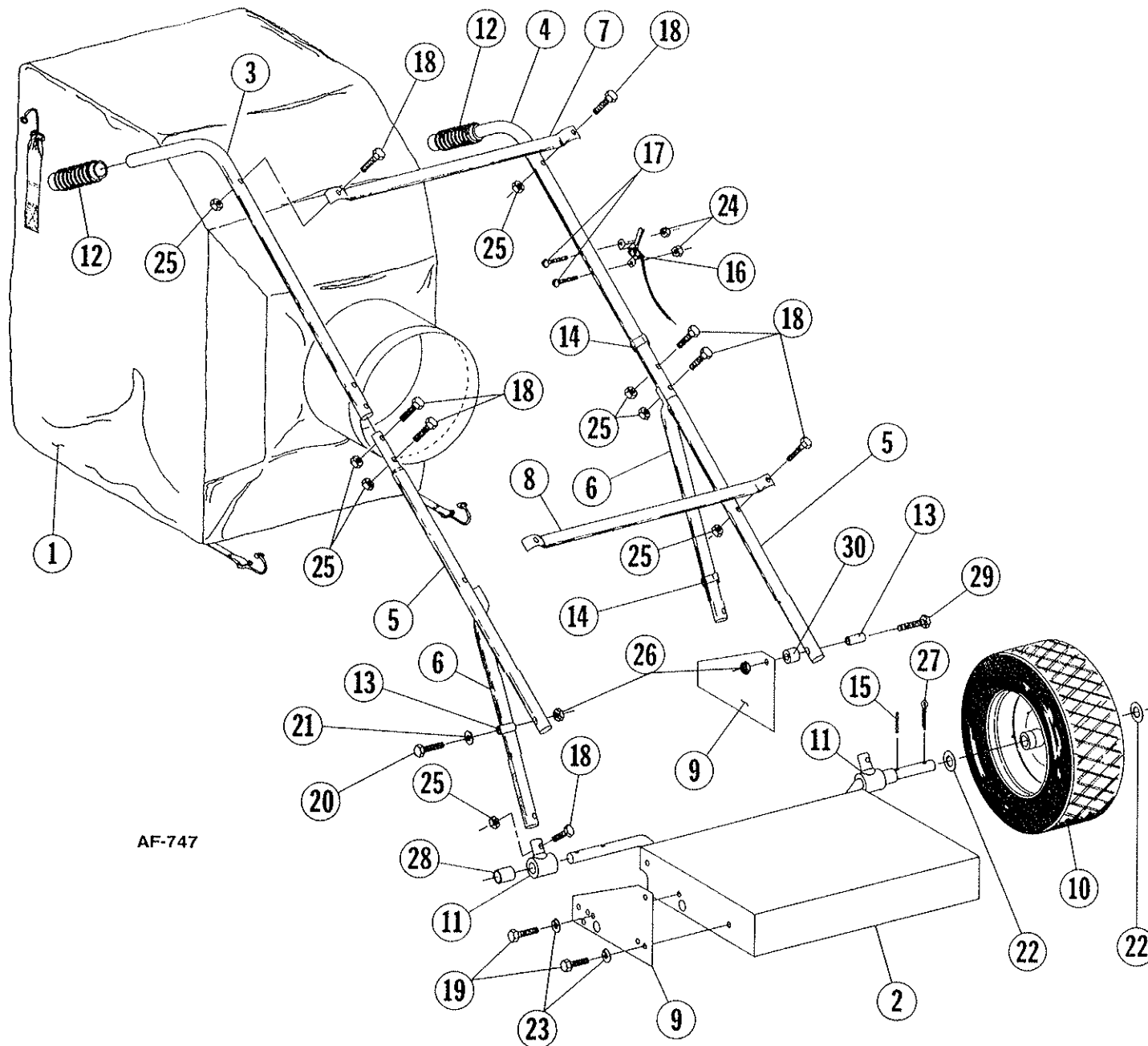

AF-747

