



Electronic Service Manuals

This electronic document is provided as a service to our customers. We do not create the contents of the information contained in this document. Should you have detailed questions pertaining to the information contained in this document, you may contact Michco, or the manufacturer which provided the original information in this electronic deliverable. Michco's only part in this electronic deliverable was the electronic assembly process. By providing this manual on line we are not guaranteeing parts availability.

You may contact Michco through the following methods:

Phone (517) 484-9312 or (800) 331-3339

2011 N. High St. -- Lansing, Michigan -- 48906

Fax: (517) 484-9836

Email: CustServe@Michco.com

Web site: www.Michco.Com

Parts Web site: www.FloorMachineParts.Com

Order Parts on Line at:

www.FloorMachineParts.Com

Directly to Parts & Service:

By Email: **Shop@Michco.com**

By Fax: (517) 702-2041

By Voice: Use numbers above.

Serving the Cleaning Industry Since 1922

Notice: All copyrighted material remains property of original owners, all trademarks are property of respective owners. Manuals are subject to Manufacturer's reproduction limitations. Originals or reproductions were provided by manufacturers through a request. We make no warranty as to the correctness of information provided in this document and you assume all risk. By placing these manuals on line we are not declaring our corporation to be an manufacturer authorized dealer or provider, please check our web site for authorized manufacturers we represent.

Minuteman[®] Parker[®]

SKIRT KITS FOR

24" INTAKE HOUSING
30" INTAKE HOUSING
36" INTAKE HOUSING

Part No.
MA-613-C
MA-614-C
MA-615-C

ASSEMBLY INSTRUCTIONS

MA-613-C, Skirt Kit for 24" Intake Housing
MA-614-C, Skirt Kit for 30" Intake Housing
MA-615-C, Skirt Kit for 36" Intake Housing

To Remove Old Skirt: Remove guards from end of intake housing and drill out rivets or fasteners using a 15/64 drill.

Holes for the 30" skirt are pre-punched except two holes in each end of intake housing. Attach skirt starting at the rear of housing in the center. Using the 15/64 drill, drill skirt at each end locating from holes in housing. Secure with fasteners and reassemble guards.

The 24" or 36" skirts have not been punched and all holes must be drilled. Assemble, drill all holes and secure skirt as outlined above.

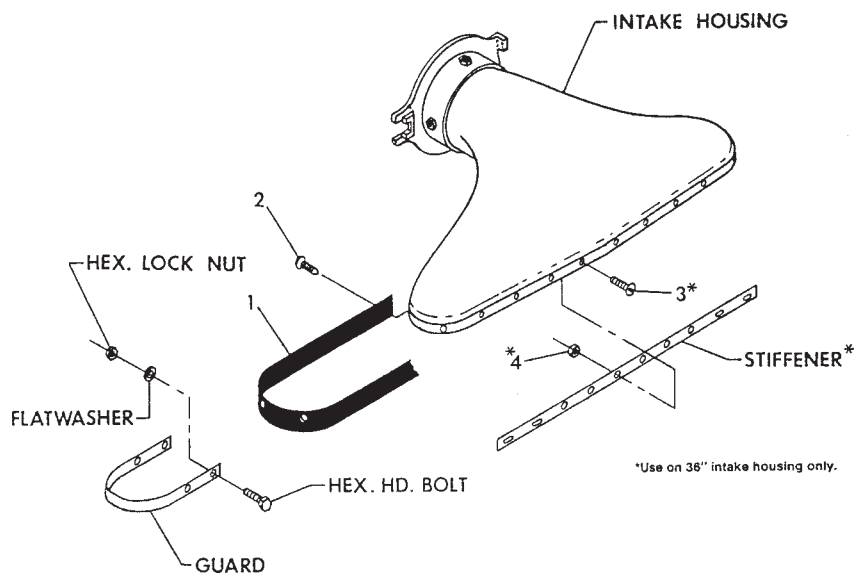

Item	Description	Qty.	For 24" Intake Assy. MA-113-D	Qty.	For 30" Intake Assy. MA-251-D	Qty.	For 36" Intake Assy. MA-120-D
1	Skirt	1	73-76-C	1	73-67-D	1	73-74-D
2	Fastener	11	80-332-A	15	80-332-A	10	80-332-A
3	Screw Rd. Hd. Mach. 10-32 x 1					7	515-10-16
4	Nut, Hex Lock 10-32					7	365-10

Minuteman[®] Parker[®]

INSTRUCTIONS FOR INSTALLING SKIRT ON 24" AND 30" INTAKE HOUSING

1. Remove hex. head bolts, flatwashers and hex lock nuts securing guards.
2. Remove guards from both ends of the intake housing.
3. Drill out original fasteners with a .191 (11) drill bit and remove. When this procedure is finished, remove original skirt.
4. Measure 3/4 inch across and 15/32 inch down on top end of new skirt (1) and mark.

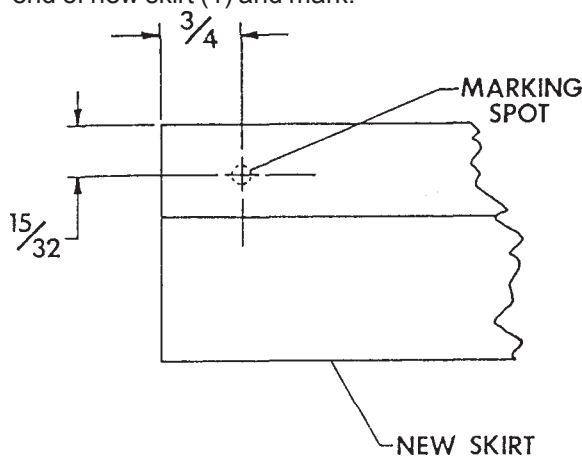

5. With mark on new skirt (1) puncture a hole into new skirt (1) through one of the middle holes on back of intake housing. Secure with fastener (2).

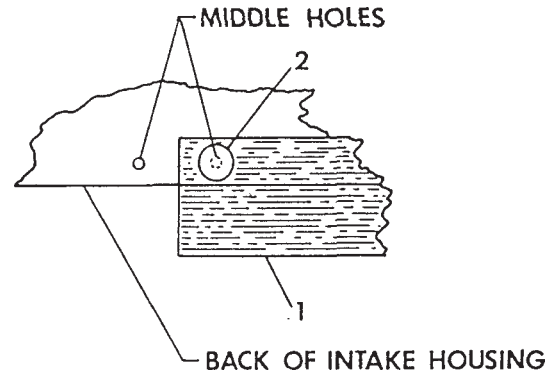

6. Place skirt (1) around bottom of intake housing.
7. Stretch skirt (1) to a position where it will be tight around intake housing. This will prevent bulging between fasteners. If overlapping, cut off excess.
8. Puncture a hole into skirt (1) through the other middle hole and secure with fastener (2). Skirt ends should be touching.
9. With skirt tightly placed on intake housing puncture holes into skirt (1) through holes of the intake housing.
10. Secure new fasteners (2) into skirt (1) through holes of intake housing.
11. Place guards back into place and re-secure hex. head bolts, flatwashers and hex. lock nuts.

INSTRUCTIONS FOR INSTALLING SKIRT ON 36" INTAKE HOUSING

1. Remove hex. head bolts, flatwashers and hex. lock nuts securing guards.
2. Remove guards for intake housing.
3. Drill out original fasteners on back and pop-rivets on front of intake housing with a .191 (11) drill bit and remove. When this procedure is finished remove original skirt and stiffener.
4. Follow instructions 4 through 9 of the first instruction assembly.
5. Secure fasteners (2) to new skirt (1) on the back and both sides of intake housing. DO NOT put fasteners on front of take housing.
6. Place guard and stiffener back into place and secure with hex. head bolts, flatwashers and hex. lock nuts.
7. Place the seven round head machine screws (3) into skirt (1), through holes, and through stiffener. Secure with hex. lock nuts (4).

Minuteman[®] Parker[®]

A Minuteman International Company

World Headquarters
Minuteman International, Inc.
111 South Rohlwing Road
Addison, Illinois 60101

(630) 627-6900
FAX (630) 627-1130

Minuteman Canada, Inc.
2210 Drew Road
Mississauga, Ontario
L5S 1B1

(905) 673-3222
FAX (905) 673-5161

000687
Printed in U.S.A.

Minuteman[®] Parker[®]

SKIRT KITS FOR

24" INTAKE HOUSING
30" INTAKE HOUSING
36" INTAKE HOUSING

Part No.
MA-113-D
MA-251-D
MA-120-D

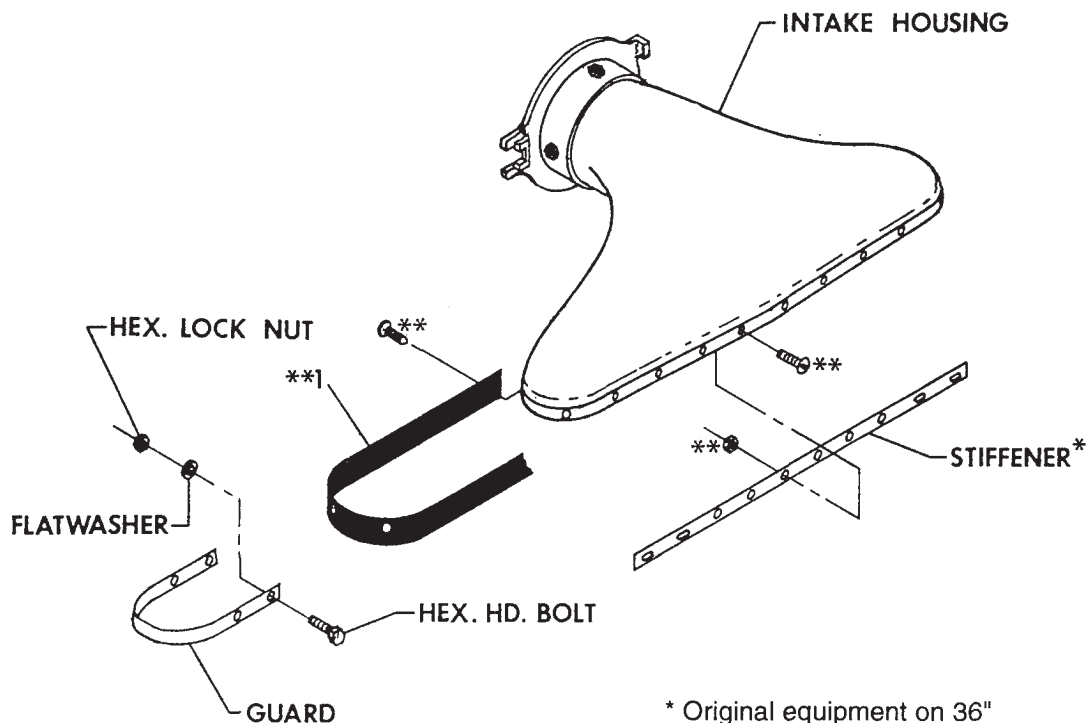

* Original equipment on 36" Intake Housing only.

** 1 Skirt supplied with intake housing but can be purchased separately as:

MA-613-C, Skirt Kit for 24" Intake Housing

MA-614-C, Skirt Kit for 30" Intake Housing

MA-615-C, Skirt Kit for 36" Intake Housing

Skirt Kits include skirt and hardware for assembly. Holes must be drilled in the 24 and 36 inch skirts by assembling to housing and drilling through holes where rivets were removed.

See Parts Price List

Minuteman[®] Parker[®]

A Minuteman International Company

World Headquarters
Minuteman International, Inc.
111 South Rohlwing Road
Addison, Illinois 60101

(630) 627-6900
FAX (630) 627-1130

Minuteman Canada, Inc.
2210 Drew Road
Mississauga, Ontario
L5S 1B1

(905) 673-3222
FAX (905) 673-5161

000687
Printed in U.S.A.