



Electronic Service Manuals

This electronic document is provided as a service to our customers. We do not create the contents of the information contained in this document. Should you have detailed questions pertaining to the information contained in this document, you may contact Michco, or the manufacturer which provided the original information in this electronic deliverable. Michco's only part in this electronic deliverable was the electronic assembly process. By providing this manual on line we are not guaranteeing parts availability.

You may contact Michco through the following methods:

Phone (517) 484-9312 or (800) 331-3339

2011 N. High St. -- Lansing, Michigan -- 48906

Fax: (517) 484-9836

Email: CustServe@Michco.com

Web site: www.Michco.Com

Parts Web site: www.FloorMachineParts.Com

Order Parts on Line at:

www.FloorMachineParts.Com

Directly to Parts & Service:

By Email: **Shop@Michco.com**

By Fax: (517) 702-2041

By Voice: Use numbers above.

Serving the Cleaning Industry Since 1922

Notice: All copyrighted material remains property of original owners, all trademarks are property of respective owners. Manuals are subject to Manufacturer's reproduction limitations. Originals or reproductions were provided by manufacturers through a request. We make no warranty as to the correctness of information provided in this document and you assume all risk. By placing these manuals on line we are not declaring our corporation to be an manufacturer authorized dealer or provider, please check our web site for authorized manufacturers we represent.

Minuteman[®]
Parker[®]

Model:
PL9616B

Truck Loader

OPERATION

SERVICE

PARTS

CARE

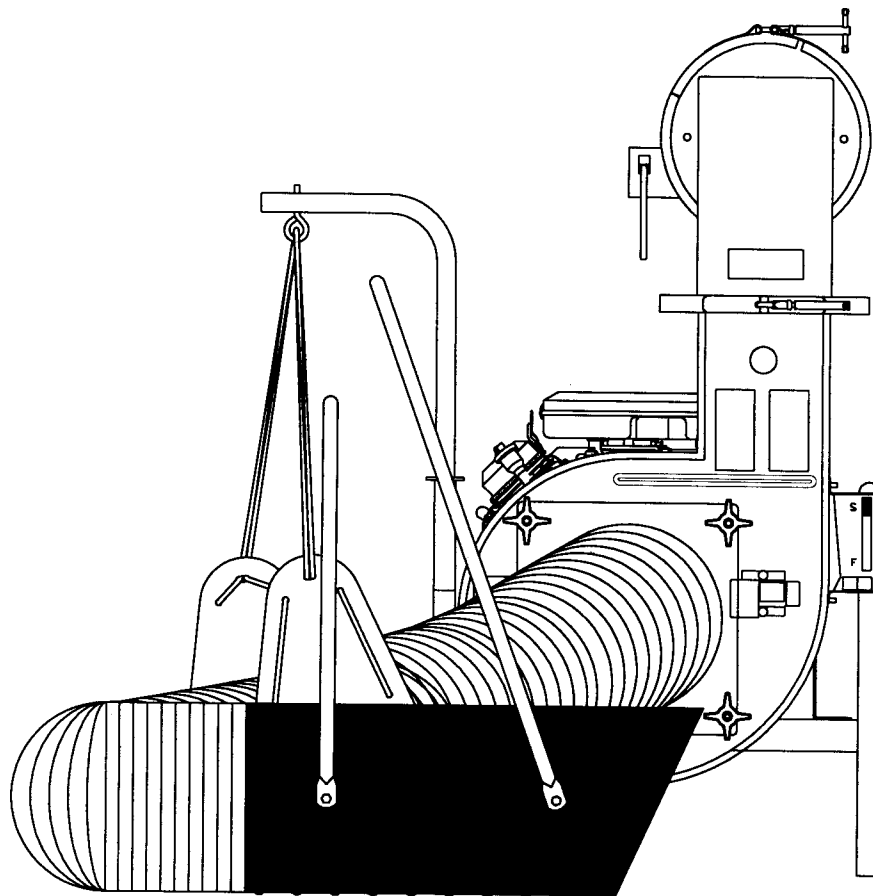



DECLARATION OF CONFORMITY

MANUFACTURER'S NAME: Minuteman International Inc.

MANUFACTURER'S ADDRESS: 111 South Rohlwing Road
Addison, IL. 60101

EQUIPMENT DESCRIPTION: PORTABLE LOADER

EQUIPMENT MODEL DESIGNATION: PL9616B

Application of Council Directives: 89/392/EC, 2000/14/EC, 91/368/EC, 98/37/EC

Harmonized EN standards complied with: EN 292

Additional Standards: ISO 3744, ISO 11094

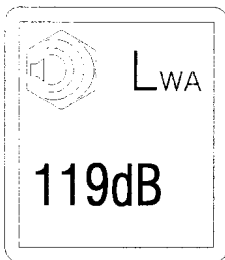

I, the undersigned, hereby declare that the equipment specified above conforms to the above Directive(s) and Standard(s).

SIGNATURE: Jeffrey Pollack **DATE:** April 24, 2004

PRINTED NAME: Jeffrey Pollack
TITLE: Standards Engineer

IMPORTANT SAFETY INSTRUCTIONS

READ ALL INSTRUCTIONS BEFORE USING

WARNING

- To prevent personal injury or property damage, do not attempt to start engine until all assembly steps are complete and you have read and understand the safety and operating instructions in this manual.
- Under California law, and under laws of several other states, you are not permitted to operation internal combustion's engine using hydrocarbon fuels on any forest covered, brush covered, or grass covered land, or on land with grain, hay, or other flammable agricultural crop, without an engine spark arrester in continuous effective working order. The engine on your power equipment, like most outdoor power equipment, is an internal combustion engine that burns gasoline, a hydrocarbon fuel. Therefore, your power equipment must be quipped with a spark arrester muffler in continuous effective working order. The spark arrester must be attached to the engine exhaust system in such a manner that flames or heat from the system will not ignite flammable material. Failure of the owner/operator of the equipment to comply with this regulation is a misdemeanor under California law, and may also be a violation of other state and/or federal regulations, laws, ordinances, or codes. Contact your local fire marshal or forest service for specific information about what regulations apply in your area.
- Wear approved safety glasses when operating this equipment. The operation of any powered machine can result in foreign objects being thrown by high-speed rotating parts.
- Wear work gloves, sturdy footwear, and hearing protection when operating this equipment.
- Remove hearing protection and watch for traffic when operating near, or when crossing roadways.
- Before inspecting or servicing any part of equipment, shut off engine, disconnect spark plug wire from spark plug, and make sure that all moving parts have come to a complete stop. Be aware that rotating blades slow down gradually after engine is shut off.
- Exercise extreme caution on slopes and avoid excessively steep slopes.
- Never leave equipment unattended when engine is running. Shut off engine and disconnect spark plug wire from spark plug before leaving equipment. Turn off fuel shut-off if equipped.
- Do not vacuum any burning or smoldering materials such as cigars, cigarettes, ashes, or cinders.
- Do not vacuum areas that have been recently treated with fertilizers, pesticides, or herbicides. Follow chemical manufacturer's safety instructions regarding contact with treated areas.
- Do not vacuum flammable liquids such as gasoline, kerosene, diesel fuel, paint thinner, etc.
- Do not operate this equipment on a paved, gravel, or hard surface unless the collection bag is installed. Discharged material may bounce from a hard surface.
- Never pick up or carry equipment while the engine is running.
- Walk, never run.
- Never allow children or untrained adults to operate this equipment.
- Keep the area of operation clear of all persons, particularly small children, and pets. Keep bystanders at least 25 feet away from the area of operation.

- Do not run engine in an enclosed area. Engine exhaust contains carbon monoxide gas, a deadly poison that is odorless, colorless, and tasteless.
- Do not operate this equipment near buildings, windows, or air conditioners.
- Do not allow hands or any other part of the body or clothing inside the vacuum inlet.
- Do not start engine or operate this equipment with any safety guards or housing removed.
- Before removing or installing collection bag, shut off engine, disconnect spark plug wire from spark plug, and allow all moving parts to come to a complete stop.
- Empty the collection bag after each use. Decomposing debris could generate enough heat to catch fire. Before emptying the collection bag, shut off engine, disconnect spark plug and allow all moving parts to come to a complete stop.
- If equipment jams or becomes clogged, immediately shut off engine, disconnect spark plug and allow all moving parts to come to a complete stop. Use only a wooden stick to clear away debris.

DANGER

Gasoline is highly flammable and its vapors are explosive. To prevent personal injury or property damage:

- Do not add fuel if engine is running or still hot from recent operation. Allow engine to cool for at least three minutes.
- Do not fill fuel tank indoors. After filling, wipe up any spills and move away from gasoline fumes before starting engine.
- Do not allow open flame, matches, or smoking in area.
- Fill fuel tank with fresh, clean unleaded regular automotive gasoline, (leaded regular and unleaded or leaded premium grades of gasoline are acceptable substitutes).
- Do not mix oil with gasoline.
- Clean the area around the fuel fill cap and remove the cap from the fuel tank. Insert a clean funnel into the fuel tank.
- Fill the tank to 1/2 inch below the bottom of the filter neck to provide space for any fuel expansion.
- Reinstall the fuel fill cap securely and wipe up any spilled gasoline.

SAVE THESE INSTRUCTIONS

SAFETY DECALS

(P.N. 715318)

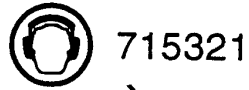

⚠ DANGER

MATERIALS EXIT FROM DISCHARGE DEFLECTOR AT HIGH SPEEDS!
KEEP HANDS, FEET, AND FACE AWAY FROM DISCHARGE DEFLECTOR TO AVOID SERIOUS INJURY.

715318

⚠ WARNING

TO AVOID SERIOUS INJURY:

- TO AVOID SEVERE BURNS, DO NOT TOUCH MUFFLER OR ADJACENT AREAS.
- TO AVOID A FIRE HAZARD, KEEP LEAVES, GRASS, AND OTHER COMBUSTIBLE MATERIALS AWAY FROM ENGINE AND MUFFLER.

715314

KEEP A SAFE DISTANCE FROM THE MACHINE

715301

DO NOT OPEN OR REMOVE SAFETY SHIELDS WHILE ENGINE IS RUNNING

715300

SAFETY INTERLOCK SWITCH

715313

READ OPERATOR'S MANUAL

715051

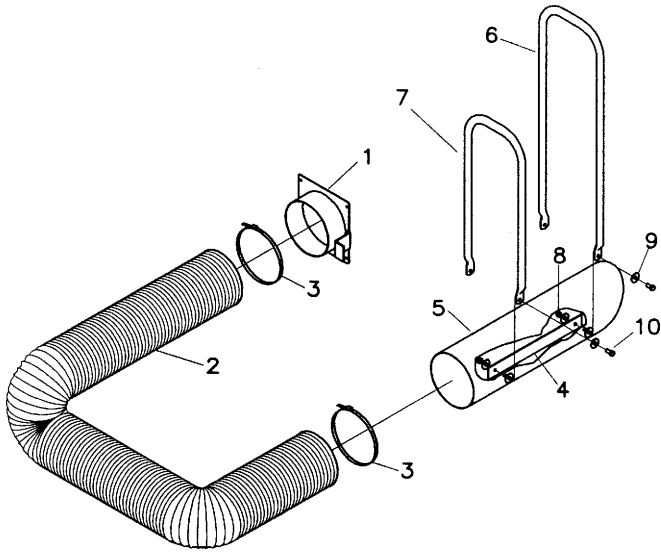

10" Hose Kit 360220

Item	Part No.	Qty.	Description
1	360207	1	Intake Adapter 10"
2	360221	1	Hose-FLX-Thane M.D 10" x 15'
3	360222	2	Clamp Hose 10" Step
4	360223	2	Reinforcing Strap
5	360224	1	Intake Tube Asy 10" Comp
6	360251	1	Handle PL 10" Tube Long
7	360252	1	Handle PL 10" Short
8	711374	4	Nut-Nyloc 5/16-18
9	711507	12	Washer Flat .37 x 1.12 x .06
10	713027	4	Bolt-HH 5/16-18 x 1 #5

Optional Accessories 8" Hose Kit 360255

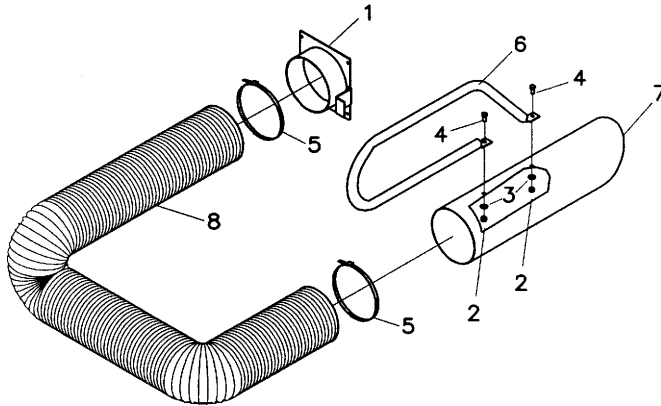

Item	Part No.	Qty.	Description
1	360256	1	Hose Adapter Weldment 8"
2	711373	2	Nut-Nyloc 1/4-20
3	711505	2	WSR-Flat 1/4
4	713001	2	Bolt-HH 1/4-20 x 5/8 #5
5	84-389-C	2	Step Clamp for 8" Hose
6	86-128-D	1	Handle
7	86-137-D	1	Intake Tube Assembly
8	87-131-B	1	Hose 8" Dia. x 16 ft. Long

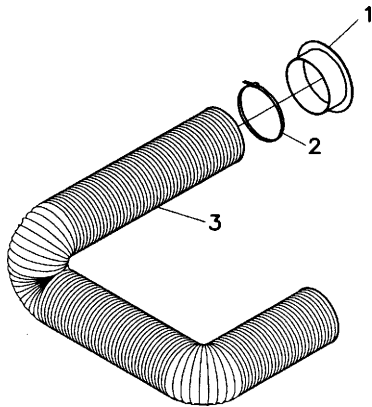

8" Exhaust Hose Kit 360246

Item	Part No.	Qty.	Description
1	360247	1	Hose Adapter Weldment 8"
2	84-389-C	1	Step Clamp for 8" Hose
3	87-131-B	1	Hose 8" Dia. x 16 ft. Long

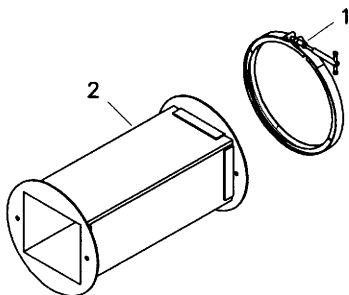

18" Extension Assembly 360226

Item	Part No.	Qty.	Description
1	360215	1	Clamp Band Assembly 2 pc
2	360260	1	18" Extension

ASSEMBLY INSTRUCTIONS

ASSEMBLING UNIT TO TAILGATE OF TRUCK

NOTE: Before assembling unit it may be desirable to purchase a rubber mat or some other covering to place over tailgate, where unit is to be assembled, to protect its finish during assembly and operation of the unit.

1. With an able-bodied person to assist, lift unit onto tailgate of truck.
2. Place 2x2 or 2x4 between lower back edge frame (1) and tailgate.
3. Holding unit, so back edge of frame (1) is flush with tailgate, turn adjusting knob on tailgate clamps (2) until rubber rings (3) are tight against inside of tailgate.
4. Turn half wing nuts (4) until tightly against frame (1) to lock unit in place.

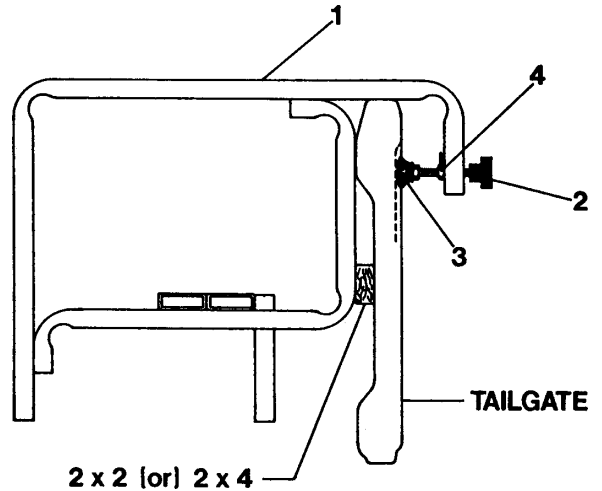

CAUTION! IT IS UNSAFE TO TRANSPORT LOADER WHILE ON TAILGATE.

ASSEMBLING HOSE TO UNIT

NOTE: This unit is equipped with a safety kill switch. When the hose adapter assembly (refer to page 6) is removed from front cover the kill switch grounds the engine, stopping unit.

CAUTION! For NO REASON should the hose be removed from the collar while it is operable. This will allow unit to remain running with no covering over intake opening in blower housing. Loose items of clothing could be drawn into unit causing serious injury. Feeding debris into open housing by hand could also cause serious injury.

OPERATING INSTRUCTIONS

CAUTION! Some method of containing debris must be used. It must fit tightly around exit chute and have no major openings that would allow debris to fly out. Running the unit without a container could cause damage to truck and seriously injure operator or persons nearby.

An optional collector bag, MA-607D, is available from Parker Sweeper for containing debris being picked up; makes removal and dumping of debris much easier.

WARNING! Although unit is equipped with a safety kill switch, NEVER reach into blower housing to remove clogs or for maintenance work without first removing the spark plug wire from the engine. This will prevent false starting of engine and also allow fan to move freely.

CAUTION! The engine contains NO OIL. Before starting the engine, make sure the crankcase is filled with the proper amount and type of oil. Refer to the engine operating manual for proper lubrication of the engine. Read the engine manual carefully before operating unit. Be sure to know how to start and stop the engine.

1. Care should be taken not to plug the hose by forcing too much debris into it at one time.
2. Stiff debris such as sticks and tree trimmings should not be picked up with the hose, as they may plug the hose.
3. If the hose becomes plugged, the engine must be shut off.
4. Remove hose from blower housing, remove all blockage from the hose and replace to blower housing.

OPERATING AND MAINTENANCE INSTRUCTIONS

READ SAFETY AND OPERATING INSTRUCTIONS BEFORE OPERATING EQUIPMENT

Best vacuum is obtained when engine is run at full throttle.

Before using the machine to pick up debris, police the area to be cleaned first, picking up any large objects. If these pass through the machine, they could damage the impeller or bend the engine crankshaft.

For servicing and operating instructions for engine refer to Engine Manufacturers Service Manual. Careful attention to care of air cleaner and crankcase lubrication instructions will insure longer engine life. KEEP ENGINE CLEAN.

Clean the engine air cleaner every 10 hours of operation. (Do so more often under dusty conditions.) If it is punctured, torn, or uncleanable it should be replaced.

Be sure to keep the oil at the proper level in the engine. Check the oil level each time you fill the fuel tank.

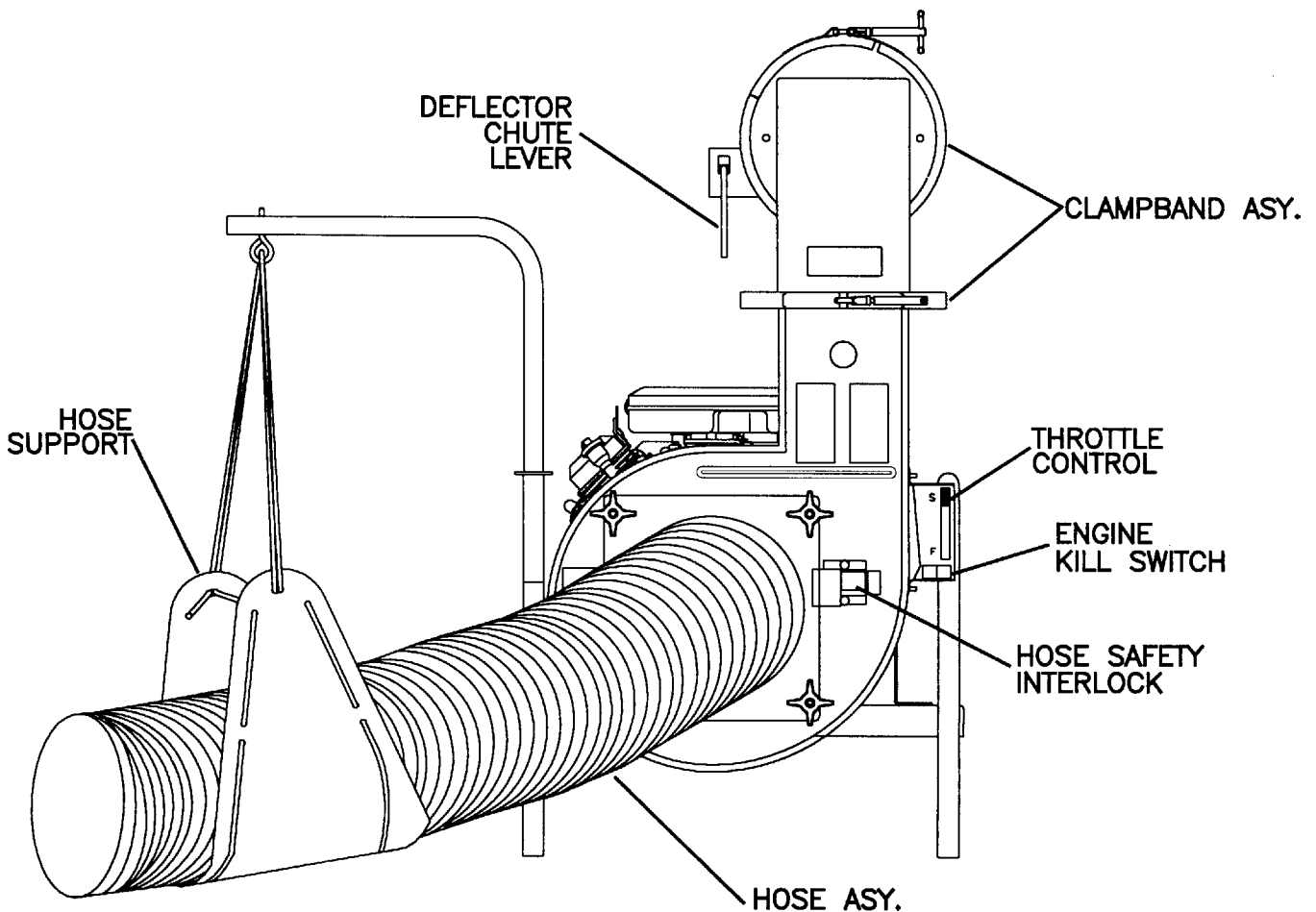

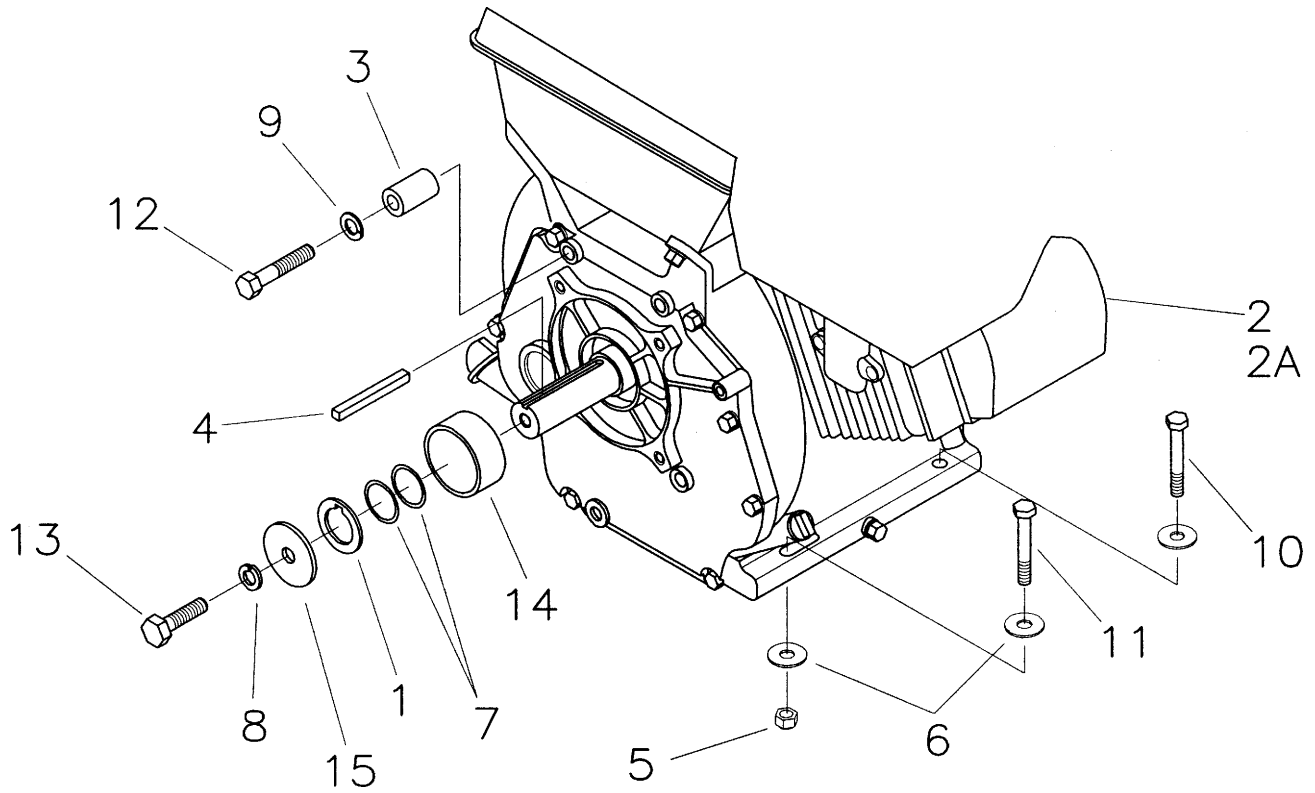

PARTS LIST

Item	Part No.	Qty.	Description
1	350284	1	Spacer-Arbor 1" 1/4" Key STL
2	360216	1	Engine 16 HP 303442 1027 A1
2A	360250	1	Muffler Kit 807970
3	57-105-A	4	Spacer .377 x .626 x 1
4	63-130-A	1	Key 1/4 x 1 3/4 Long
5	711374	4	Nut-Nyloc 5/16-18
6	711506	8	WSR-Flat 5/16 ST PL
7	711526	2	WSR-Wave 1.01 x 1.20 x .01
8	711546	1	WSR-Helical 3/8
9	711555	4	WSR-Internal Lock 3/8
10	713030	2	BLT-HH 5/16-18 x 1 3/4 #5
11	713035	2	BLT-HH 5/16 x 18 x 3 #5
12	713045	4	BLT-HH 3/8-16 x 1 3/4 #5
13	713103	1	BLT-HH 3/8-24 x 1.75 #5
14	72-179-A	1	Spacer 1 x 1.312 x 1.032
15	82-138-B-3	1	WSR-Area Vac 35

11
INC. 1, 13, 14, 15,
20, 29, AND 32

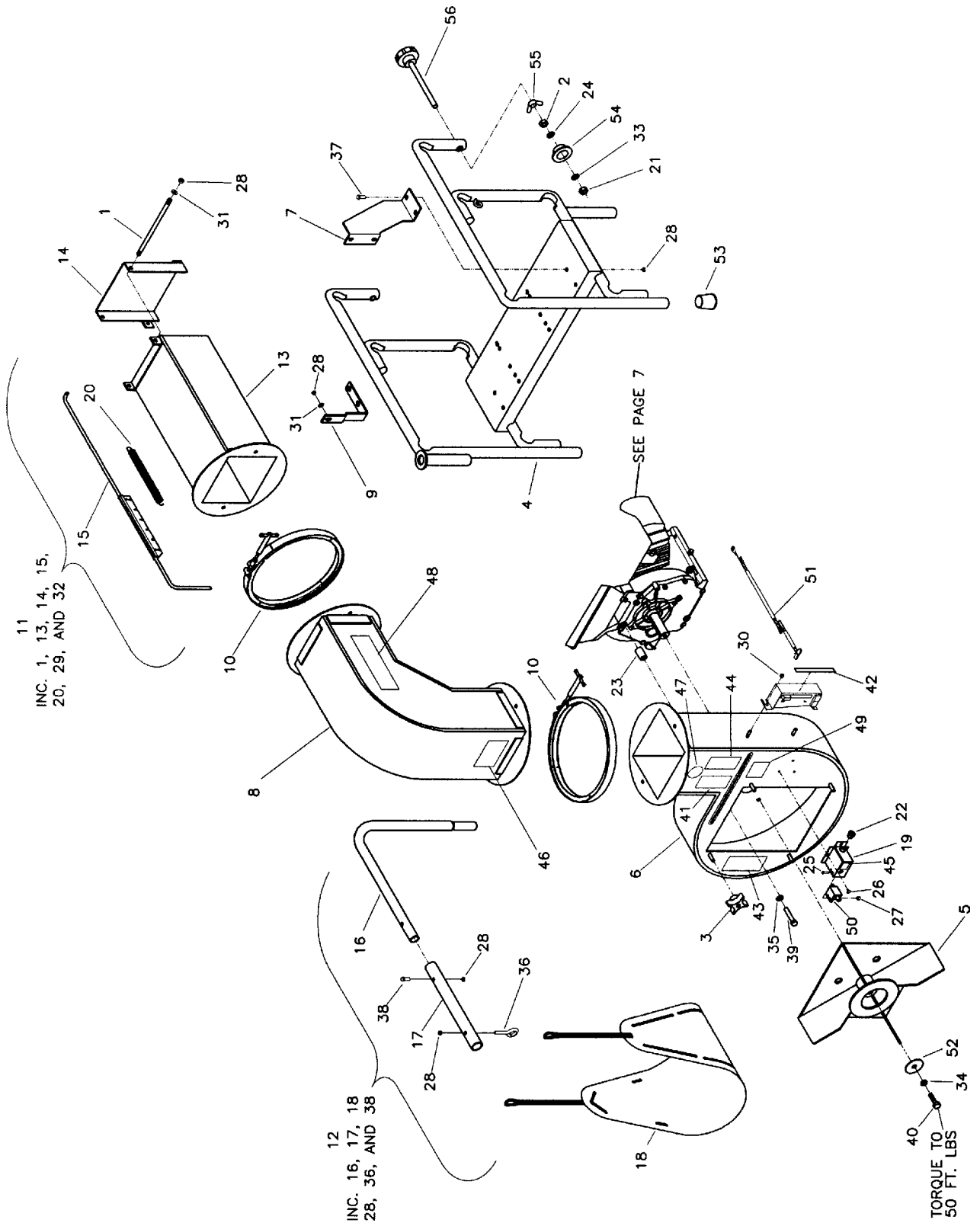

PARTS LIST

Item	Part No.	Qty.	Description
1	160033	1	Pin, Hinge
2	340-816	2	Hex Nut Jam
3	350139	4	Knob 5/16 Thread
4	350245	1	Weldment Frame
5	360115BAL	1	Fan Assembly Balanced
6	360200	1	Housing Assembly
7	360206	1	Support Plate Housing
8	360209	1	Elbow Assy. Complete
9	360212	1	Support Bracket Housing
10	360215	2	Clamp Band Assembly
11	360217	1	Deflector Assy. Complete
12	360227	1	Hose Support Assembly
13	360228	1	Deflector Assy. Exit
14	360231	1	Deflector Plate Weldment
15	360234	1	Control Rod Assembly
16	360236	1	Hose Support Tube
17	360237	1	Extension Tube
18	360238	1	Hose Support Assembly
19	360243	1	Switch Box Cover PL9616B
20	360244	1	Return Spring
21	364-816	2	Nut-Nyloc 1/2-13 Half
22	380004	1	Relief, Strain
23	57-105-A	4	Spacer .377 x .626 x 1
24	58-05-A	2	Washer Special
25	710130	2	SCR-MC 8-32 x .62
26	711124	3	SCR-ST-10 x .37
27	711372	2	Nut-Nyloc 8-32
28	711374	7	Nut-Nyloc 5/16-18
29	711380	2	Nut-Nyloc 3/8-16
30	711425	2	Nut-Flanged Wizz 1/4-20
31	711506	3	WSR-Flat 5/16 ST PL
32	711508	2	WSR-Flat .44 x 1.00
33	711509	2	WSR-Flat 1/2
34	711546	1	WSR-Helical 3/8
35	711555	4	WSR-Internal Lock 3/8
36	712030	1	BLT-Eye 5/16 x 3
37	713026	4	BLT-HH 5/16-18 x 3/4 #5
38	713030	1	BLT-HH 5/16-18 x 1 3/4 #5
39	713045	4	BLT-HH 3/8-16 x 1 3/4 #5
40	713103	1	BLT-HH 3/8-24 x 1.75 #5
41	715051	1	Decal, Read Operator Manual
42	715191	1	Decal, Speed Control
43	715300	1	Decal, Warning Fingers
44	715301	1	Decal, Warning Blower
45	715313	1	Decal, Safety Interloc
46	715318	1	Decal Danger
47	715321	1	Decal Hearing Protection
48	715322	1	Decal Diecut
49	715633	1	Decal CE
50	740282	1	Switch Delta
51	740304	1	Wire Assembly PL9616B
52	82-138-B-3	1	Special Washer
53	88-111-B	4	Leg Tip White Rubber
54	88-112-B	2	Ring, Rubber Foot
55	88-114-A	2	Wing Nut
56	88-117-B	2	Tailgate Clamp

LIMITED WARRANTY

The Parker Sweeper Company warrants to the original purchaser/user that this product is free from defects in workmanship and materials under normal use and service for a period of two years from date of purchase. In addition, Parker Sweeper Company will, at its option, honor labor warranty claims for the first 12 months from date of sale, provided such claims are submitted through and approved by factory authorized repair stations. Parker Sweeper Company will, at its option, repair or replace without charge, except for transportation costs, parts that fail under normal use and service when operated and maintained in accordance with the applicable operation and instruction manuals.

This warranty does not apply to normal wear, or to items whose life is dependent on their use and care, such as belts, cords, switches, hoses, rubber parts, electrical motor components or adjustments. Parts not manufactured by Parker Sweeper Company such as engines, batteries, battery chargers, hydraulic pumps, and tires are covered by and subject to the warranties and/or guarantees of their manufacturers. Please contact Parker Sweeper Company for procedures in warranty claims against these manufacturers.

Special warning to purchaser — Use of replacement filters and/or prefilters not manufactured by Parker Sweeper Company or its designated licensees, will void all warranties expressed or implied.

A potential health hazard exists without exact original equipment replacement.

All warranted items become the sole property of Parker Sweeper Company or its original manufacturer, whichever the case may be.

Parker Sweeper Company disclaims any implied warranty, including the warranty of merchantability and the warranty of fitness for a particular purpose. Parker Sweeper Company assumes no responsibility for any special, incidental or consequential damages.

This limited warranty is applicable only in the U.S.A. and Canada, and is extended only to the original user/purchaser of this product. Customers outside the U.S.A. and Canada should contact their local distributor for export warranty policies. Parker Sweeper Company is not responsible for costs or repairs performed by persons other than those specifically authorized by Parker Sweeper Company. This warranty does not apply to damage from transportation, alterations by unauthorized persons, misuse or abuse of the equipment, use of non-compatible chemicals, or damage to property, or loss of income due to malfunctions of the product.

If a difficulty develops with this machine, you should contact the dealer from whom it was purchased.

This warranty gives you specific legal rights, and you may have other rights which vary from state to state. Some states do not allow the exclusion or limitation of special, incidental or consequential damages, or limitations on how long an implied warranty lasts, so the above exclusions and limitations may not apply to you.

Minuteman[®]
Parker[®]

A Member of the Hako Group of Companies

World Headquarters
Minuteman International, Inc.
111 South Rohlwing Road
Addison, Illinois 60101

Phone 630-627-6900
Fax 630-627-1130
www.minutemanintl.com

Minuteman Canada, Inc.
2210 Drew Road
Mississauga, Ontario
L5S 1B1

Phone 905-673-3222
Fax 905-673-5161

999222
Printed in U.S.A.