



## Electronic Service Manuals

This electronic document is provided as a service to our customers. We do not create the contents of the information contained in this document. Should you have detailed questions pertaining to the information contained in this document, you may contact Michco, or the manufacturer which provided the original information in this electronic deliverable. Michco's only part in this electronic deliverable was the electronic assembly process. By providing this manual on line we are not guaranteeing parts availability.

You may contact Michco through the following methods:

Phone (517) 484-9312 or (800) 331-3339

2011 N. High St. -- Lansing, Michigan -- 48906

Fax: (517) 484-9836

Email: [CustServe@Michco.com](mailto:CustServe@Michco.com)

Web site: [www.Michco.Com](http://www.Michco.Com)

Parts Web site: [www.FloorMachineParts.Com](http://www.FloorMachineParts.Com)

Order Parts on Line at:

**[www.FloorMachineParts.Com](http://www.FloorMachineParts.Com)**

Directly to Parts & Service:

By Email: **[Shop@Michco.com](mailto:Shop@Michco.com)**

By Fax: (517) 702-2041

By Voice: Use numbers above.

**Serving the Cleaning Industry Since 1922**

Notice: All copyrighted material remains property of original owners, all trademarks are property of respective owners. Manuals are subject to Manufacturer's reproduction limitations. Originals or reproductions were provided by manufacturers through a request. We make no warranty as to the correctness of information provided in this document and you assume all risk. By placing these manuals on line we are not declaring our corporation to be an manufacturer authorized dealer or provider, please check our web site for authorized manufacturers we represent.

# OWNERS GUIDE

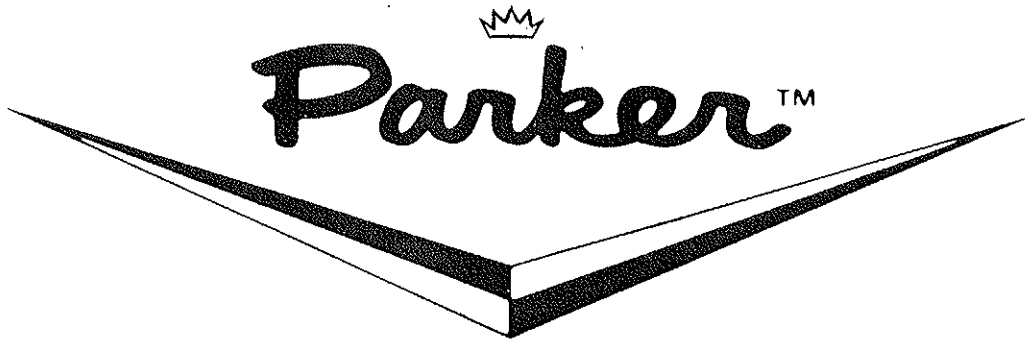

## MODEL PS-7930 POWER SWEEP

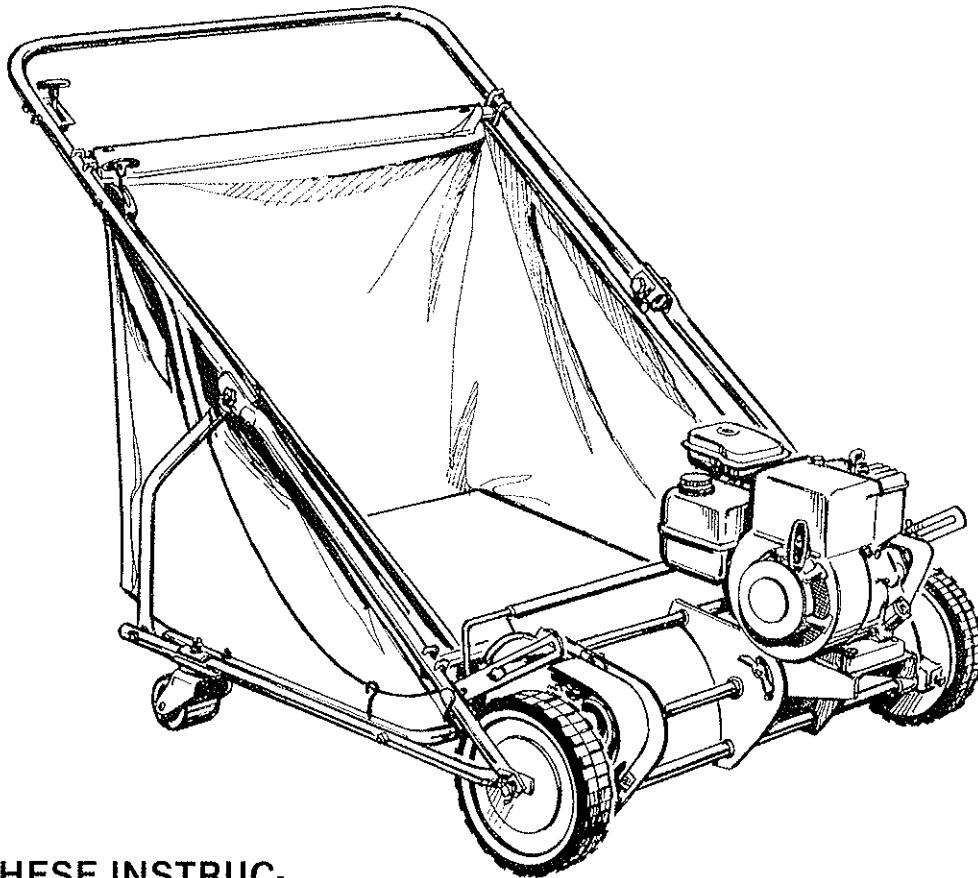

**READ THESE INSTRUCTIONS BEFORE SETTING UP AND OPERATING MACHINE.**

**PARKER SWEEPER COMPANY Box 1728 Springfield, Ohio 45501**

-Plate No. 437

# TO THE OWNER

These instructions were written to assist you in assembling and operating your Power Sweep. **READ THE INSTRUCTIONS** thoroughly **BEFORE** attempting to assemble and operate the machine, so that you are familiar with the complete procedure and the safety precautions.

## RULES FOR SAFE OPERATION



The following safety precautions are suggested to prevent damage to the equipment or injury to the operator or nearby persons.

1. Do not allow anyone to operate the Sweeper without proper instructions.
2. Do not permit children to operate the Sweeper.
3. Do not sweep too close to fire, because the Basket and Brushes will burn.
4. Do not attempt to remove wire or string from around the Brushes while the Engine is running.
5. Stop the Engine completely before attempting to make any adjustment or performing any maintenance work on the Sweeper.
6. Operate the Sweeper at reduced speed on rough terrain, in ditches and on hillsides, to prevent loss of control. Stay alert for holes or other hidden hazards.
7. Watch for traffic when sweeping near roadways.
8. Keep all nuts, bolts and screws tight, to be sure the Sweeper is in safe working condition.
9. Before starting to sweep an area it should be inspected; and all foreign objects such as wire, bones, stones, sticks and other debris likely to damage the machine or cause personal injury should be removed.
10. Follow the maintenance instructions as outlined in this manual.
11. To prevent accidental starting always remove the spark plug before working on the engine or equipment driven by the engine.
12. Do not run the engine in an enclosed area. Exhaust gases contain carbon monoxide, an odorless and deadly poison.
13. Do not fill gasoline tank while engine is running. Spilling gasoline on a hot engine may cause a fire or explosion.
14. Do not leave machine unattended while running.



This is a power operated Sweeper and the Engine should never be started unless the Clutch is in neutral. The Clutch is in neutral when the Clutch Lever is pulled to the rear.

# TO THE OWNER

Your Power Sweep is shipped complete in one carton. Empty the carton but do not discard it or the inserts until you have completely assembled the machine. The right or left side of the machine is determined from the operator's position at the rear of the machine.

Identify the parts you have removed from the cartons.  
You should Have:

- 1 — The Sweeper Head, Engine and Frame Assembly
- 2 — The Upper Handle.
- 3 — Two Handle Support Tubes.
- 4 — The Basket Assembly.
- 5 — A Plastic Bag containing the Engine Instruction Manual.
- 6 — A Plastic Bag containing the Owners Guide.
- 7 — A Plastic Bag containing the necessary hardware to assemble the machine.

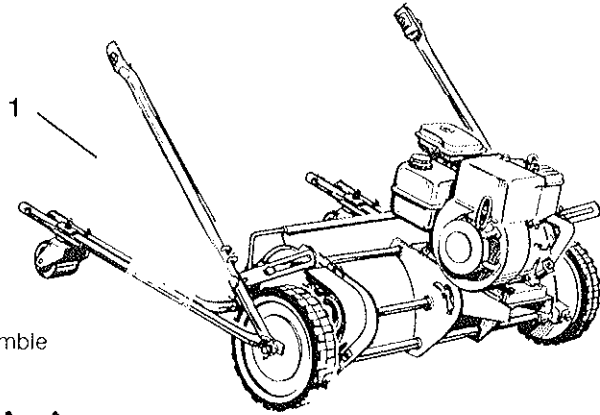

The plastic bag should contain the following hardware:

**The plastic bag should contain the following:**

- (2)  $\frac{1}{4}$ -20 X  $1\frac{1}{2}$  Bolt Hex Head.
- (3)  $\frac{1}{4}$ -20 X  $1\frac{1}{2}$  Bolt Hex Head.
- (1)  $\frac{1}{4}$ -20 X  $3/4$  Hexagon Head Bolt.
- (8)  $\frac{1}{4}$ -20 Nut-Hexagon Plain.
- (2)  $\frac{1}{4}$ -20 Nut-Hexagon Thin.
- (2) 10-24 X 1-1/8 Screw - Oval Head.
- (2) 10-24 Nut Hexagon Lock.
- (2) 8-32 X  $\frac{1}{2}$  Screw Round Head.
- (2) 8-32 Nut-Hexagon Lock.
- (2) Clamp - Cable.
- (4)  $\frac{1}{4}$ -20 X  $1\frac{1}{4}$  Bolt-Contour Head.
- (4) Clip - Retainer.
- (4)  $\frac{1}{4}$  Washer-Spring Lock.

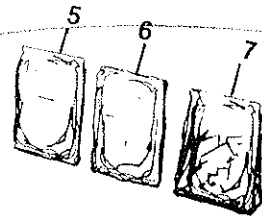
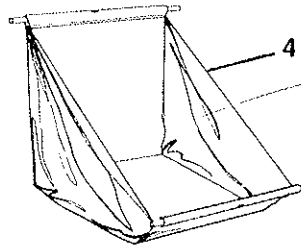
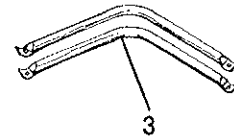
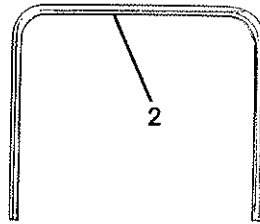

You will need two  $\frac{1}{2}$ " wrenches, two  $\frac{7}{16}$ " wrenches, one  $\frac{3}{8}$ " wrench, one  $\frac{5}{16}$ " wrench, and a screwdriver to assemble your Sweeper.

## HOW TO ORDER REPAIR PARTS

The Model number will be found printed on the Hood. Always mention the Model number when requesting service or ordering repair parts for your Lawn Sweeper.

The Parts List will note that some parts are for the right side of the Sweeper and some are for the left side. To determine the right and left side, stand behind your Sweeper facing the direction the Sweeper will move when in operation. The left side of your Sweeper is at your left, and the right side of the Sweeper is at your right side.

All parts listed in this book may be ordered from any authorized "Parker" dealer. However, if the parts you need are not stocked locally, you may order from Parker Sweeper Company, P.O. Box 1728, Springfield, Ohio 45501.

WHEN ORDERING REPAIR PARTS, ALWAYS GIVE THE FOLLOWING INFORMATION:

1. PART NUMBER (NOT REF. NO.)
2. PART DESCRIPTION
3. MODEL NUMBER (FROM THE HOOD)
4. NAME OF THE SWEEPER

# ASSEMBLY INSTRUCTIONS

Attach the Upper Handle and the Handle Support Tubes to the Lower Handle, using two  $\frac{1}{4}$ -20 x  $1\frac{1}{4}$  Hex Head Bolts, Lock Washers and Nuts, but do not tighten. Note that the side with the extra holes is the Right Hand Side of the Upper Handle. Raise the Handle and using two more  $\frac{1}{4}$ -20 x  $1\frac{1}{4}$  Bolts, attach the lower end of the Handle Support Tube to the inside of the Frame just behind the Casters and tighten the four  $\frac{1}{4}$ -20 Bolts you have just installed.

To prevent personal injury use extreme caution when uncoiling the Clutch Control and Throttle Control cables.

Uncoil the Clutch Control Assembly that is attached to the Sweeper Head, being careful not to bend the cable. Bending the cable at sharp angles will affect the control operation.

Pass the cable over the lower frame assembly and inside the handle support tube and attach the Control Lever Assembly to the inside of the Handle using the two #10-24 X  $1\frac{1}{4}$  machine screws and Lock Nuts and tighten securely. Install one of the  $\frac{3}{4}$  Cable Clamps over the Right Hand Handle just below the Handle Joint and attach the Clutch Control Cable to the Handle with one of the #8-32 Screws and Lock Nuts.

Uncoil the Throttle Control Assembly and attach the Lever Assembly End to the inside of the Handle with two  $\frac{1}{4}$ -20 x  $1\frac{1}{4}$  Bolts and Thin Lock Nuts. Install the second Cable Clamp on the Throttle Cable at a point about 4-5 inches above the lower Basket Bracket and secure with the #8-32 x  $\frac{1}{2}$  Screw and Lock Nut.

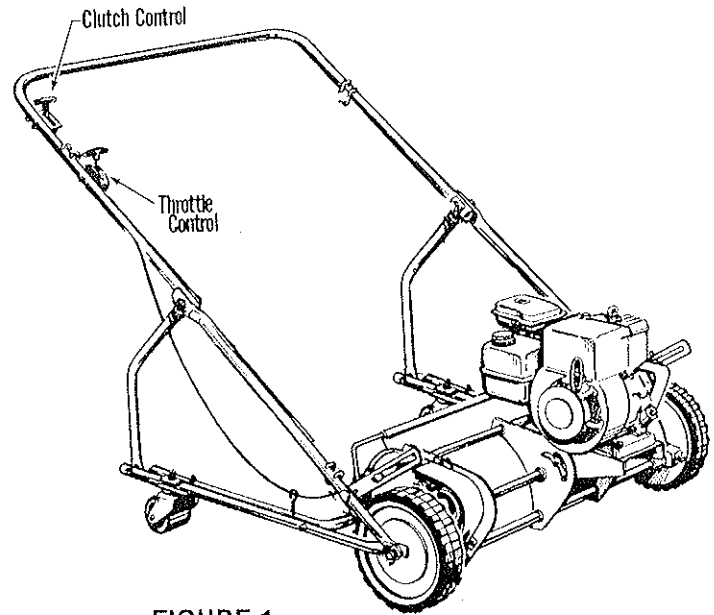

FIGURE 1

Unfold the Basket and install it in the Brackets between the Handles.

Service the Engine with oil and gasoline according to the instructions in the Engine Manual. Now your Power Sweeper is ready to operate.

# MAINTENANCE INSTRUCTIONS

Frequent lubrication of the Sweeper will lengthen the service life. Place a few drops of oil in the oil holes in the hub of each wheel and in the swivel bearings and axles of the casters before each use.

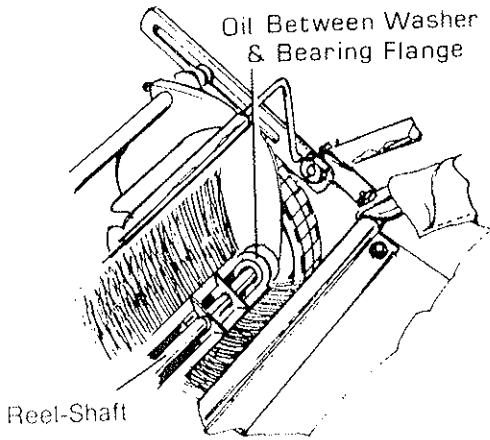

FIGURE 2

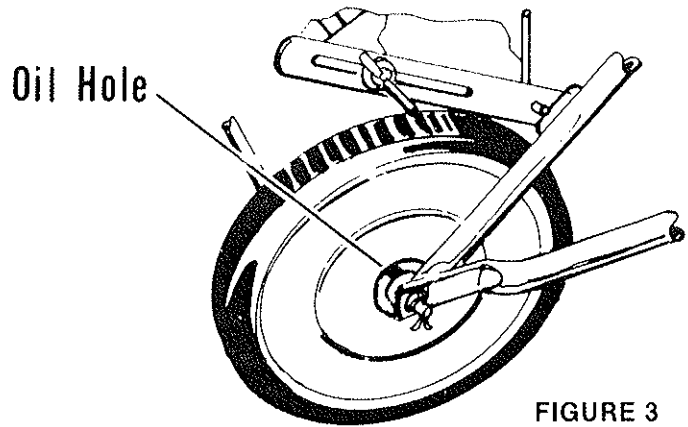

FIGURE 3

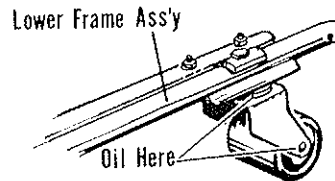

FIGURE 4

Also place a few drops of oil in the Brush Reel Bearings in the Side Plates, and on the Clutch and Throttle Control Wires.

Change the Engine oil and clean the Engine Air Filter according to the instructions in the Engine Manual. Empty the Basket after each use and before storing. The Basket material will not rot, but the service life can be greatly extended by keeping it clean and dry. Before using the Sweeper for the first time each season, remove both Wheels and put a good grade of grease on the Pinions and in the Gears on the Wheels.

## BRUSH CARE & REPLACEMENT

Should the Brush Bristles become bent from use, reverse the position of the Brushes on the Reel Shaft. Never allow the Brushes to remain in a bent position on any object for any length of time, because they will take a set and remain bent.

To remove the Brushes, raise them to the highest brushing position and tilt the Engine to provide working clearance around the Sweeper head. Notice that the Brush Stud has a Collar on one side and a Speed Nut Retainer on the other side. Remove the Hexagon Nuts and Brush Clamps from the end of the Brush Studs having the Collar first. This will free two Brushes. Then rotate the Reel and remove the Nuts and Clamps from the Brush Studs on the end with the Retainer. This will free the second set of two Brushes. Do not remove the Brush Stud Retainers, for they keep the Studs and Brush Brackets assembled to the Reel.

To replace the Brushes, turn the Reel Shaft so that you can install the new Brushes in the Brackets that are held on by the Stud Retainer. (**NOT THE COLLAR**). Then, position the Brushes so that they will clear the Side Plates and install the Clamps and Nuts. Rotate the Reel and install the second set of Brushes. The third and fourth set are installed the same as the first two.

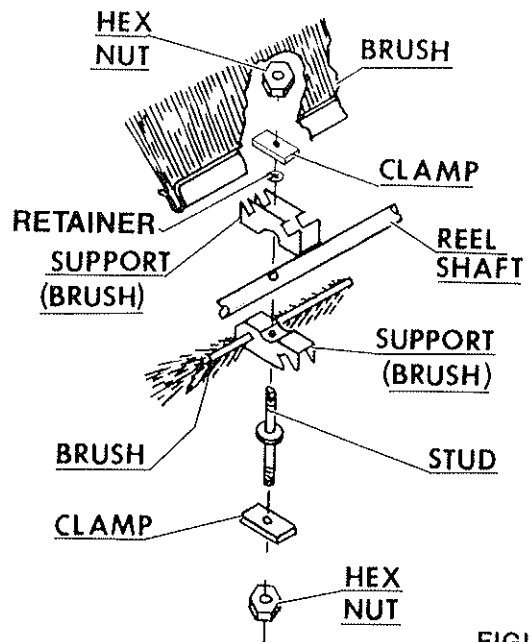

FIGURE 5

## OPERATING INSTRUCTIONS



Remember that this is a power operated Sweeper and the Engine should never be started unless the Clutch is in neutral. The Clutch is in neutral when the Clutch Lever is pulled to the rear. When the Clutch Lever is pushed forward, the machine will move forward. When it is pulled backward, the machine will stop. There is no power reverse on this machine. To make it back up, you must put the Clutch in "STOP" position and manually pull the machine backward.

**BRUSH HEIGHT ADJUSTMENT.** Loosen large Wing Nut. To raise Brushes to extreme height, pull sweeping unit forward as far as slots in Brush Adjustment Brackets will permit. To lower Brushes to lowest position, push sweeping unit backward as far as slots will permit. Secure Wing Nut when desired brush adjustment is obtained.

1. For grass clippings or leaves, adjust Brushes to highest positions. After trial run on lawn, should the settings be too high, lower slightly and try again until correct setting is found. Brush life may be prolonged by adjusting so contact with ground is light.
2. For patio, sidewalk, and driveway sweeping, adjust Brushes so they just contact pavement.

After Brush has been set to desired height, it may be necessary to level the Engine. To do this, loosen Wing Nut, and pivot Engine up or down.

To start the Engine, first pull the Clutch Lever backward to put the Clutch in neutral. Push the Throttle all the way forward to open the Throttle. Then close the Choke and pull the Starter Rope. When the Engine starts, open the Choke. You can control the engine speed with the Throttle Control on the Right Handle. With the lever fully forward the Engine will run at its highest governed speed. Pulling the Throttle Control Lever toward the rear, will slow the Engine speed and pulling it all the way to the rear will stop the Engine.

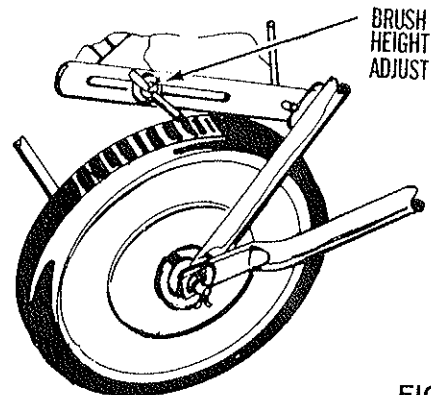

FIGURE 6

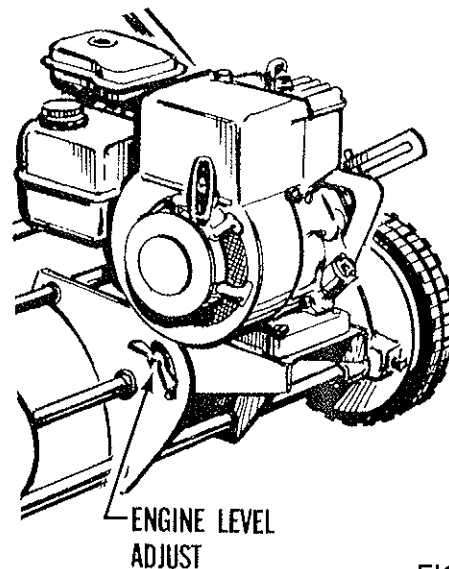
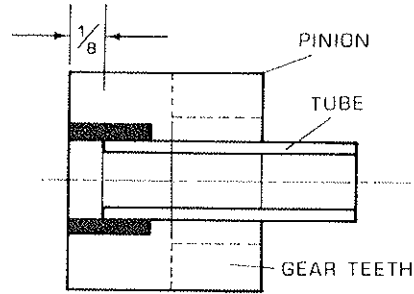
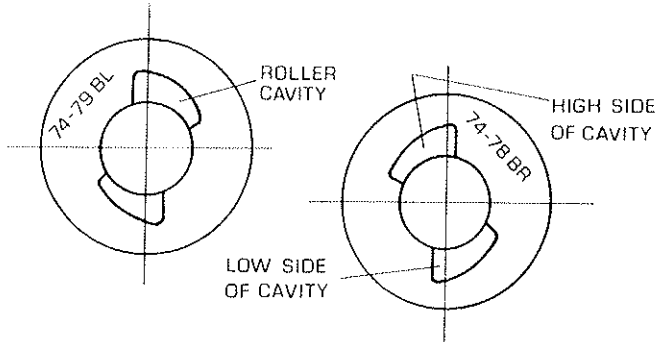

FIGURE 7

# HOW TO RE-INSTALL PINIONS

If, for some reason, it becomes necessary to remove the Pinions from the Reel Shaft, they can be easily replaced by following the instructions below: A piece of tubing 5/8 dia. x 2" long will make installation easier.



- NOTE** that the Pinions are stamped with the letters BR & BL. The BR Pinion is a Right Hand Pinion. However, BECAUSE THIS IS A POWER SWEEPER, THE **RIGHT HAND PINION** MUST BE INSTALLED ON THE **LEFT HAND SIDE** OF THE REEL SHAFT AND THE **LEFT HAND PINION** IS TO BE INSTALLED ON THE **RIGHT HAND SIDE** OF THE REEL SHAFT.

- Push the Tube back into the Pinion, so that it is 1/8" inside the Pinion, on the side where the Rollers are located.

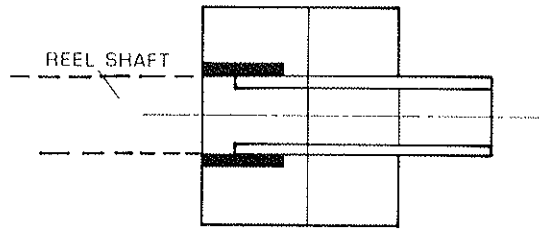
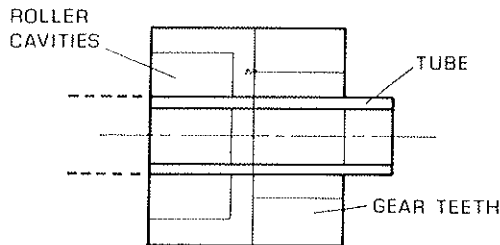

- Install the Pinion over the 5/8" diameter Tube and position the Tube flush with the side of the Pinion at the side with the Roller cavities.

- Place the Pinion, Roller end first, over the end of the Reel Shaft and push the Pinion off the Tube and onto the Reel Shaft. Be sure to put the Right Hand Pinion on the left hand end of the Reel Shaft.

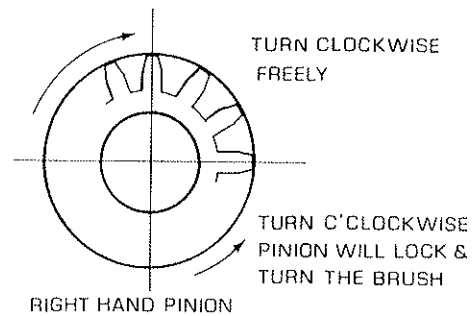
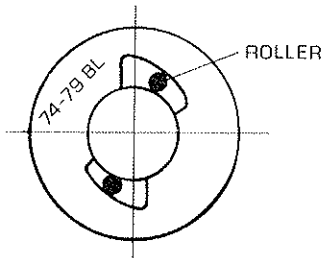

- Now install a Roller in the cavity and turn the Pinion until the Roller is tight between the Tube and the outside of the cavity.

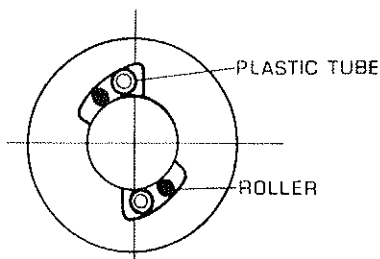

- Turn the Right Hand Pinion clockwise; it should rotate freely. Turn it counterclockwise, and it should rotate the Brush.
- Follow steps #2 thru #6, and install the Left Hand Pinion.
- Turn the Left Hand Pinion counterclockwise and it should rotate freely. Turn it clockwise, and it should rotate the Brush.

- With the Roller tight between the Tube and the wall of the cavity, insert one of the plastic Tubes between the Roller and the high side of the cavity.

- Grease the Gear and the Pinion Teeth, and replace the Wheels.

Now, following the instructions #3 & #4, install the second Roller and plastic Tub in the second cavity.

# REPAIR PARTS — SUPPORT FRAME ASSEMBLY — MODEL NO. PS-7930

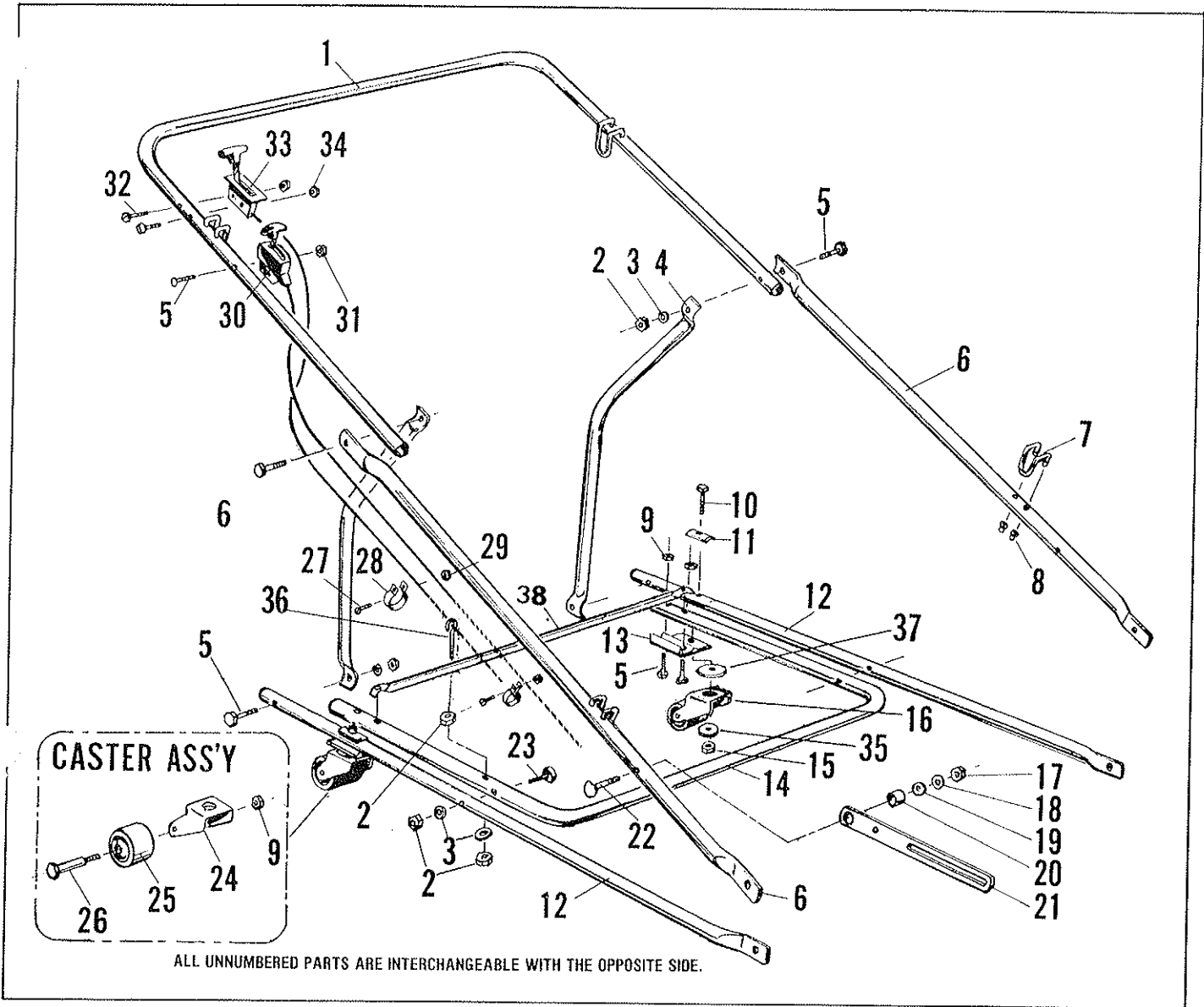

## PARTS LIST

Ref. No.	Part No.	Qty. Per Unit	Description of Part	Ref. No.	Part No.	Qty. Per Unit	Description of Part
1	76-416 - C	1	Upper Handle	20	54-227 - A	2	Spacer
2	335-416	8	Nut 1/4-20 Hexagon Plain	21	60-21 - A	2	Adjusting Bracket
3	935-416	7	Lock Washer 1/4 Spring	22	69-516-24	2	Bolt 5/16-18 x 1 1/2 Cont. Head
4	75-52 - B	2	Handle Support	23	69-416-28	2	Bolt 1/4-20 x 1 1/2 Cont. Head
5	65-416-20	5	Bolt 1/4-20 x 1 1/4 Hex Head	24	76-143 - B	2	Caster Fork Assembly
6	76-418 - B	2	Lower Handle	25	76-58 - A	2	Caster Roller
7	<del>76-415</del>	4	Basket Support <b>80-110 - A</b>	26	76-202 - A	2	Caster Axle
8	77-10 - A	8	Push Nut	27	515-8-8	2	Screw #8-32 x 1/2 Round Head
9	365-416	4	Nut 1/4-20 Hexagon Lock	28	<del>68-101</del>	2	Cable Clamp
10	65-516-32	2	Bolt 5/16-18 x 2 Hex Head	29	365-8	2	Nut #8-32 Hexagon Lock
11	59-77 - A	2	Tube Clamp	30	<del>75-56</del>	1	Throttle Control <b>83-25-B-64</b>
12	76-417 - B	2	Lower Side Frame	31	364-416	1	Nut 1/4-20 Hexagon Lock Thin
13	76-81 - B	2	Caster Plate	32	<del>517-10-18</del>	2	Screw #10-24 x 1 1/8 Oval Head
14	76-419 - B	1	Frame Support	33	77-20 - A	1	Clutch Control
15	365-516	2	Nut 5/16-18 Hexagon Lock	34	365-10	2	Nut #10-24 Hexagon Lock
16	SA-578 - B	2	Caster Assembly	35	50-230 - A	2	Special Washer
17	335-516	2	Nut 5/16-18 Hexagon Plain	36	<del>60-168</del>	1	Eye Bolt
18	935-516	2	Lock Washer 5/16 Spring	37	78-130 - A	2	Bearing
19	945-516	2	Flat Washer 5/16	38	79-108 - B	1	Basket Support

REPAIR PARTS — SWEEPER UNIT ASSEMBLY — MODEL NO. PS-7930

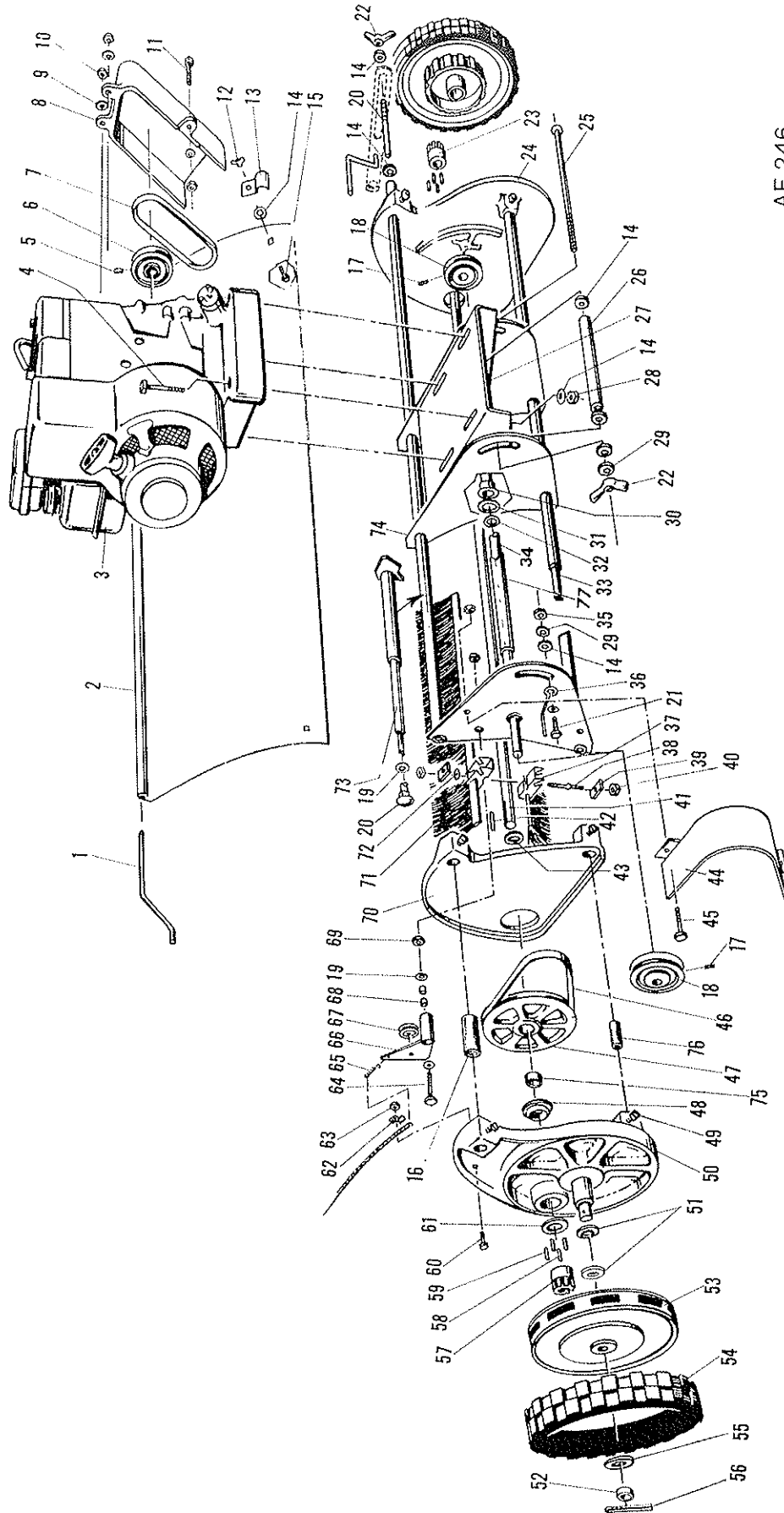

AF 246

SWEeper UNIT AND ENGINE ASSEMBLY

PARTS LIST

Ref. No.	Part No.	Description of Part	Qty. Per Unit	Ref. No.	Part No.	Description of Part	Qty. Per Unit
1	76-443-A	Hood Control Rod	2	40	362-416	Nut 1/2-20 Self Locking	6
2	<del>76-07</del>	Hood <del>84-246-C</del>	1	41	79-09-B	Reel Shaft	1
3	<del>76-70</del>	Engine B&S 3 1/2 H.P.	1	42	72-246-A	Reel Shaft Key	1
4	65-516-24	Bolt 1/8-18 x 1 1/2 Hexagon Head	4	43	55-161-A	Special Washer 3/8	2
5	564-416-6	Set Screw 1/4-20 x 3/8 Allen	1	44	76-441-C	Belt Guard	1
6	75-55-A	Engine Sheave	1	45	65-416-8	Bolt 1/4-20 x 1/2 Hexagon Head	2
7	76-433-A	Vee Belt 3L-230	1	46	76-432-A	Vee Belt 3L-310	1
8	77-21-C	Belt Guard	1	47	75-44-B	Reel Shaft Sheave	1
9	945-416	Flat Washer 1/4	2	48	68-60-A	Reel Shaft Sheave	2
10	335-416	Nut 1/4-20 Hexagon Plain	4	49	560-C-516-10	Set Screw 1/8-18 x 3/8 Square Head	6
11	65-416-12	Bolt 1/4-20 x 3/4 Hexagon Head	2	50	<del>66-08</del>	Side Plate Right Hand	1
12	351-416-18	Wing Nut 1/4-20	2	51	946-1216-24	Fiber Washer 3/4	2
13	60-22-A	Hood Clamp	2	52	77-81-A	Axel Spacer	2
14	945-516	Flat Washer 3/8	10	53	49-377-C	Wheel	2
15	<del>70-16-12</del>	Carriage Bolt 1/4-20 x 3/4	2	54	78-124-B	Tire	2
16	<del>70-12</del>	Adjusting Tube Spacer	1	55	946-816-16	1/2 Fiber Washer	2
17	564-C-516-6	Set Screw 1/8-18 x 1/2 Allen	2	56	380-432-16	Cotter Pin 1/8 x 1	2
18	76-430-A	Jack Shaft Sheave	2	57	<del>74-79-B</del>	Pinion Left Hand	1
19	945-616	Flat Washer 3/8	2	58	<del>74-80-A</del>	Roller Pawl	4
20	76-442-A	Adjusting Bolt	1	59	<del>76-37-A</del>	Pawl Spring	4
21	65-516-12	Bolt 1/8-18 x 3/4 Hex Head	1	60	515-8-8	Screw #8-32 x 1/2	1
22	73-71-A	Wing Nut 3/8	2	61	50-33-A	Special Washer 3/8 Flat	2
23	74-78-B	Pinion Right Hand	1	62	75-115-A	Throttle Cable Clip	1
24	<del>68-04</del>	Side Plate Left Hand	1	63	365-8	Nut #8-32 Hexagon Lock	1
25	70-516-104	Bolt Engine Adjusting	1	64	65-616-48	Bolt 3/8-16 x 3 Hexagon Head	1
26	76-422-A	Clamp Tube	1	65	77-19-A	Clutch Spring	1
27	76-421-C	Engine Mount	1	66	77-02-B	Clutch Arm Weldment	1
28	365-516	Nut 1/8-18 Hexagon Lock	4	67	76-456-A	Clutch Pulley	1
29	935-516	Lock Washer 3/8 Spring	2	68	77-05-A	Clutch Arm Bearing	2
30	76-435-A	Jack Shaft Bearing	3	69	335-616	Nut 3/8-16 Hexagon Plain	2
31	946-816-16	Fiber Washer	3	70	60-20-B	Inner Side Plate	1
32	76-14-A	Retainer	2	71	1200-14-5	Brush Strip	8
33	76-429-A	Tie Rod	1	72	75-89-A	Stud Retainer	4
34	76-434-A	Jack Shaft	1	73	76-428-A	Adjusting Tube	1
35	335-516	Nut 1/8-18 Hexagon Plain	1	74	79-08-B	Engine Mount Weldment	1
36	70-71-A	Belt Popper	1	75	79-11-A	Pully Spaces	1
37	74-13-C	Brush Bracket	6	76	79-13-A	Tie Rod Spacer	1
38	74-16-A	Brush Stud	4	77	79-111-B	Shaft Protector	1
39	69-04-A	Brush Clamp	8				

*Pattern Kit*

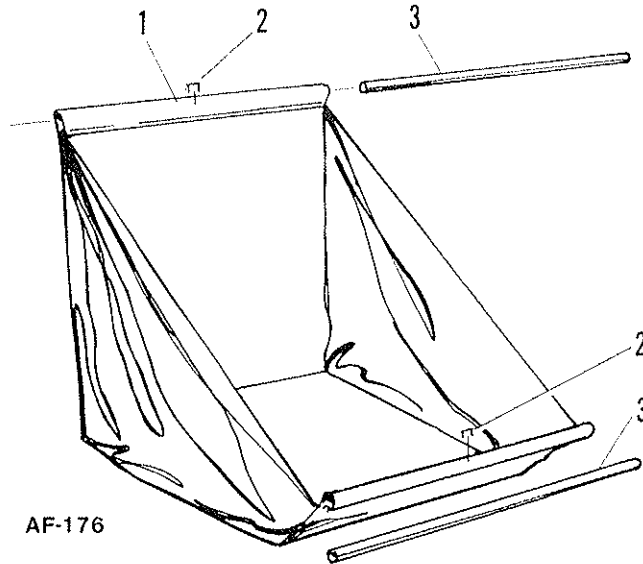

AF-176

PARTS LIST

Ref. No.	Part No.	Qty. Per Unit	Description of Part
1	SA-796-D	1	Basket Sides and Bottom
2	<del>62-171</del> 82-236-B	2	Staple
3	77-13-A	2	Basket Rod

WIND APRON ATTACHMENT

Remove wing nut and flat washer. Pull bolt out slowly, take off second flat washer and finish pulling bolt out. There is one flat washer on opposite side—be sure to replace it in same position. Place apron loops on adjusting tube next to side plate on outside. Replace bolt, flat washers and wing nut. Readjust brushes to proper height. Fasten hooks at top basket rod up against basket support brackets.

Loops Must Be Placed On Outside Of Side Plate As Shown.

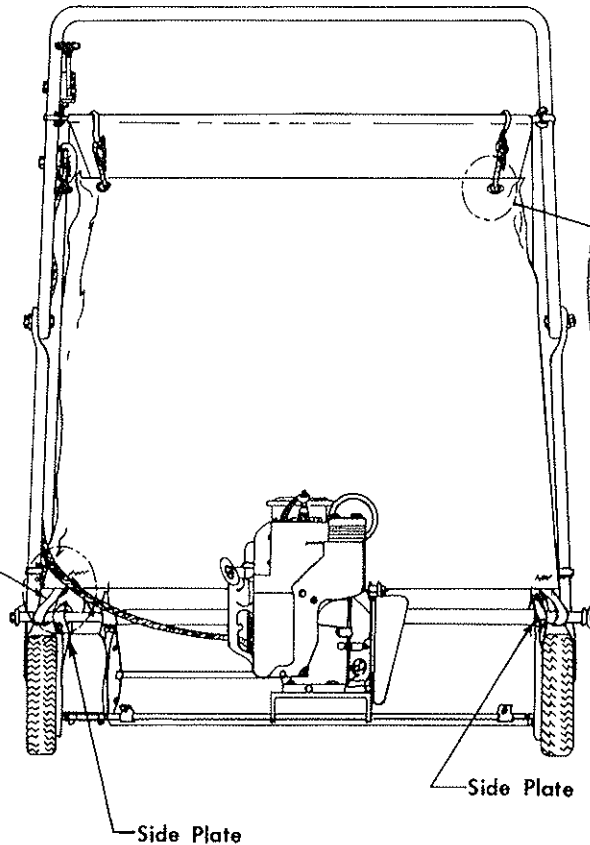

Rear View:  
Adjust Rope Tension  
By Moving Knot  
Up Or Down.

AF-269

Please follow these instructions carefully to assemble new Clutch Arm Assembly. Numbers used in these instructions refer to those in AF-01 below.

1. Remove small spiral Pin that sets Clutch Arm Assy. with Clutch Weldment (1) using small punch or nail.
- NOTE: If a small diameter punch cannot be found. Start the Pin out with some other small diameter or pointed object and pull pin out using vise grips or pliers.
2. Remove Shaft Retainer (6) securing Clutch Weldment (1) in Pivot Arm. Also remove outside Flatwasher (7).
  3. Remove Pivot Arm from Clutch Weldment (1) and move it out of the way. Do Not remove other Flatwasher (7) and Spacer (8) from Clutch Weldment (1).
  4. SLOWLY pull Clutch Weldment (1) straight away from R.H. Side Plate. As shaft is being removed be careful not to lose Special Washer (3) and Spacer (4), once they have fallen from shaft STOP PULLING.
  5. There should be enough space to now remove old clutch Arm Assembly from Clutch Weldment (1).
  6. Place new Clutch Arm Assembly onto Clutch Weldment, being sure pulley is toward Inner Side Plate.
  7. Reassemble Spacer (4) then Special Washer (3) as pushing Clutch Weldment back into place.
  8. Check to make sure both Bushings (2) are seated properly in Side Plates.
  9. Reattach Pivot Arm to Clutch Weldment (1), replace Flatwasher (7) and Shaft Retainer (6) to secure.
  10. Align hole in Clutch Arm Assembly with hole in shaft of Clutch Weldment (1) and secure with new Spiral Pin.
- NOTE: Maintain hole alignment while driving Spiral Pin through Clutch Arm Assembly and Clutch Weldment.

