



## Electronic Service Manuals

This electronic document is provided as a service to our customers. We do not create the contents of the information contained in this document. Should you have detailed questions pertaining to the information contained in this document, you may contact Michco, or the manufacturer which provided the original information in this electronic deliverable. Michco's only part in this electronic deliverable was the electronic assembly process. By providing this manual on line we are not guaranteeing parts availability.

You may contact Michco through the following methods:

Phone (517) 484-9312 or (800) 331-3339

2011 N. High St. -- Lansing, Michigan -- 48906

Fax: (517) 484-9836

Email: [CustServe@Michco.com](mailto:CustServe@Michco.com)

Web site: [www.Michco.Com](http://www.Michco.Com)

Parts Web site: [www.FloorMachineParts.Com](http://www.FloorMachineParts.Com)

Order Parts on Line at:

**[www.FloorMachineParts.Com](http://www.FloorMachineParts.Com)**

Directly to Parts & Service:

By Email: **[Shop@Michco.com](mailto:Shop@Michco.com)**

By Fax: (517) 702-2041

By Voice: Use numbers above.

**Serving the Cleaning Industry Since 1922**

Notice: All copyrighted material remains property of original owners, all trademarks are property of respective owners. Manuals are subject to Manufacturer's reproduction limitations. Originals or reproductions were provided by manufacturers through a request. We make no warranty as to the correctness of information provided in this document and you assume all risk. By placing these manuals on line we are not declaring our corporation to be an manufacturer authorized dealer or provider, please check our web site for authorized manufacturers we represent.

OPERATING INSTRUCTIONS AND PARTS LIST



**PS-6225 POWER SWEEP**

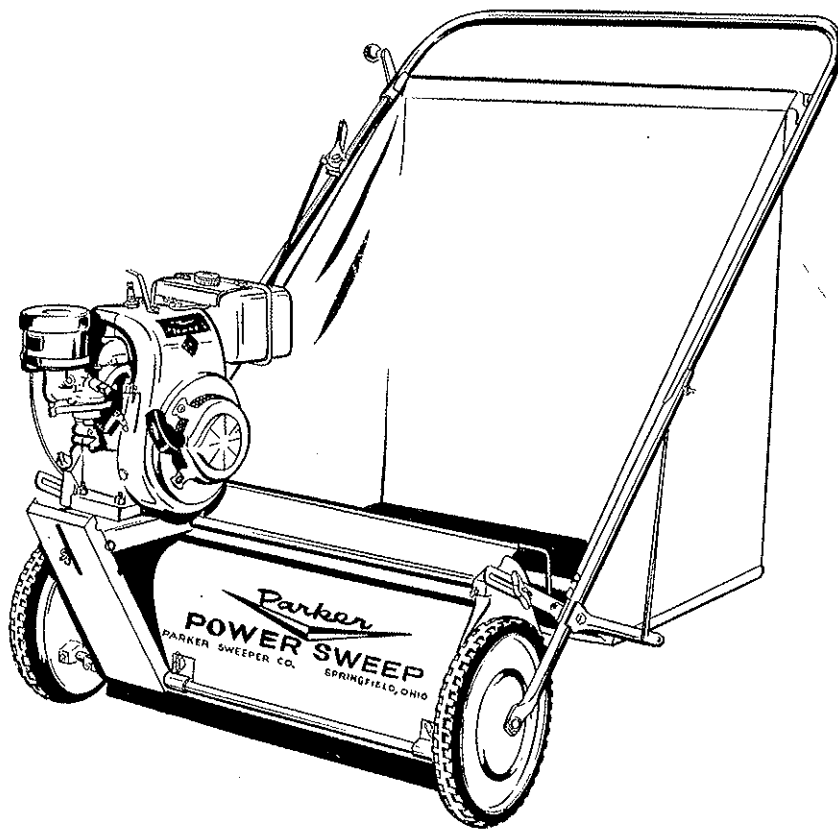

NOTICE: These instructions were written to assist you in assembling your Lawn Sweeper quickly and correctly. Read instructions thoroughly before attempting assembly so that you are familiar with the complete procedure.

**PARKER SWEEPER COMPANY**

BOX 720

SPRINGFIELD, OHIO

## ASSEMBLY INSTRUCTIONS

1. Remove sweeper from carton and set on ground in an upright position. Loosen large wing nut, Ref. No. 9, Fig. 2, and let engine tilt back. Bring upper handle, Ref. No. 39, up over engine and back until it lies on ground. *HEX*
2. Remove Rd. Hd. screw, hex nut, and lock washer, Ref. Nos. 5, 6, and 7, Fig. 2, from one side of upper handle and reverse direction of screw so head is to inside of handle. Replace hardware being sure to reassemble brace, Ref. No. 23, Fig. 1, as it was originally (see opposite side). Note: Do not tighten at this time.
3. Repeat instruction No. 2 for opposite side.
4. Raise engine up until level and retighten large wing nut. Assemble lower end of brace by removing hex nut and lock washer, Ref. Nos. 9 and 10, Fig. 1, from one side of caster frame and place end of brace onto carriage bolt. Replace nut and washer.
5. Assemble opposite brace to caster frame in similar manner. Raise upper handle until in proper position and tighten all four nuts; also tighten hex nuts, Ref. No. 17, Fig. 2.
6. Remove Rd. Hd. screw, hex nut, and ~~lock washer~~, Ref. Nos. 3, 4, and 31, Fig. 2, from end of clutch rod. Match two ends of rod together and replace hardware in hole. Tighten both screws.
7. Screw plastic knob onto handle, Ref. No. 35, Fig. 2.
8. With metal bottom of basket level with ground, place basket into position as shown on front cover.

## OPERATING INSTRUCTIONS

**Important:** Read engine manual carefully before operating, and add oil and gasoline to engine as instructed. When ready to start engine, be sure that clutch is disengaged.

**Brush Height Adjustment.** Loosen large wing nut, Ref. No. 9, Fig. 2. To raise brushes to extreme height, pull sweeping unit forward as far as slots in brush adjustment brackets, Ref. No. 11, Fig. 2, will permit. To lower brushes to lowest position, push sweeping unit backwards as far as slots will permit. Secure wing nut when desired brush adjustment is obtained.

1. For grass clippings or leaves, adjust hood extension, Ref. No. 10, Fig. 3, and brushes to highest positions. After trial run on lawn, should the settings be too high, lower slightly and try again until correct setting is found. Brush life may be prolonged by adjusting so contact with ground is light.
2. For patio, sidewalk, and driveway sweeping, adjust hood extension to bottom position. Also adjust brushes so they just contact cement. Always keep engine approximately level at all times. To do this, loosen wing nut, Ref. No. 7, Fig. 3, and pivot engine up or down to desired slot in brace, Ref. No. 14.

NOTE: IF SWEEPER PUSHES HARD, THE BRUSHES OR HOOD EXTENSION IS SET TOO LOW.

**Basket.** Basket is removable for dumping.

**Maintenance.** Lubricate the sweeper about once each season to insure long unit life and easy operation.

1. Oil at points marked "oil" (see Fig. 1).
2. It is not necessary to oil nylon brush bearings.

**Care and Replacement of Brushes.** The brushes used on this sweeper are made of the finest bristles that will give years of service if given proper care. Should they become bent from constant use, dampening and straightening will reset the bristles upright. It is also possible to straighten bristles by reversing the brushes on the reel shaft.

To reverse or replace brushes:

1. Turn sweeper upside down on ground.
2. Remove the bolts which hold the brush sections to the reel shaft. Reverse and replace the brushes and retighten the bolts.

**Basket Care.** The lumite basket is impervious to moisture. However, to insure longer life, empty basket after each use.

## ALWAYS GIVE THE FOLLOWING INFORMATION WHEN ORDERING REPAIR PARTS

If you are unable to obtain parts locally, write to the factory for the name of nearest service dealer.

1. Part Number and Quantity.
2. Model Number (found on hood).
3. Serial Number (found on guarantee card).

Your unit is right hand (R.H.) or Left Hand (L.H.) as you stand behind it.

\*Standard hardware items may be purchased locally.

# SUPPORT FRAME AND ENGINE ASSEMBLY

## Figure 1

Ref. No.	Part No.	Description	Qty. Req'd.	Ref. No.	Part No.	Description	Qty. Req'd.
1	62-97A	Engine	1	16	59-77A	Clamp	1
2	*60-516-32	Hex Head Bolt $\frac{5}{16}$ -24 x 2	2	17	63-52A	Roller	1
3	*936-516	Lock Washer $\frac{5}{16}$	7	18	<del>59-68B</del>	Pivot Block U.S. Std. 30-265-A	1
4	60-58A	Spacer	2	19	*65-516-28	Hex Hd. Bolt $\frac{5}{16}$ - 18 x 1 $\frac{1}{4}$	1
5	60-55A	Pulley - 2" O.D. x $\frac{5}{16}$ Bore	1	20	55-156A	Washer - Special	2
6	*565-516-6	Set Screw - Slot Head - $\frac{5}{16}$ - 18 x $\frac{3}{8}$	1	21	54-227A	Spacer	1
7	60-27B	Belt Guard	1	22	*335-516	Hex Nut $\frac{5}{16}$ - 18	5
8	*70-416-16	Carriage Bolt $\frac{1}{4}$ - 20 x 1	2	23	60-40B	Brace	2
9	*936-416	Lock Washer $\frac{1}{4}$	3	24	62-40F	Caster Support Frame	1
10	*335-416	Hex Nut $\frac{1}{4}$ - 20	5	25	48-277A	Key $\frac{3}{16}$ x $\frac{3}{16}$ x 1 $\frac{1}{2}$	1
11	45-71A	Bushing	1	26	*65-516-24	Hex Head Bolt $\frac{5}{16}$ - 18 x 1 $\frac{1}{2}$	4
12	*945-516	Washer SAE $\frac{5}{16}$	4	27	60-83B	Guard - Anti-Weed Wrap	4
13	*515-416-44	Rd. Hd. Screw $\frac{1}{4}$ - 20 x 2 $\frac{3}{4}$	1	28	*935-416	Lock Washer - Spring $\frac{1}{4}$	4
14	60-29B	Caster Fork	1	29	47-229A	Cable Clip	1
15	*515-416-36	Rd. Hd. Screw $\frac{1}{4}$ - 20 x 2 $\frac{1}{4}$	2				

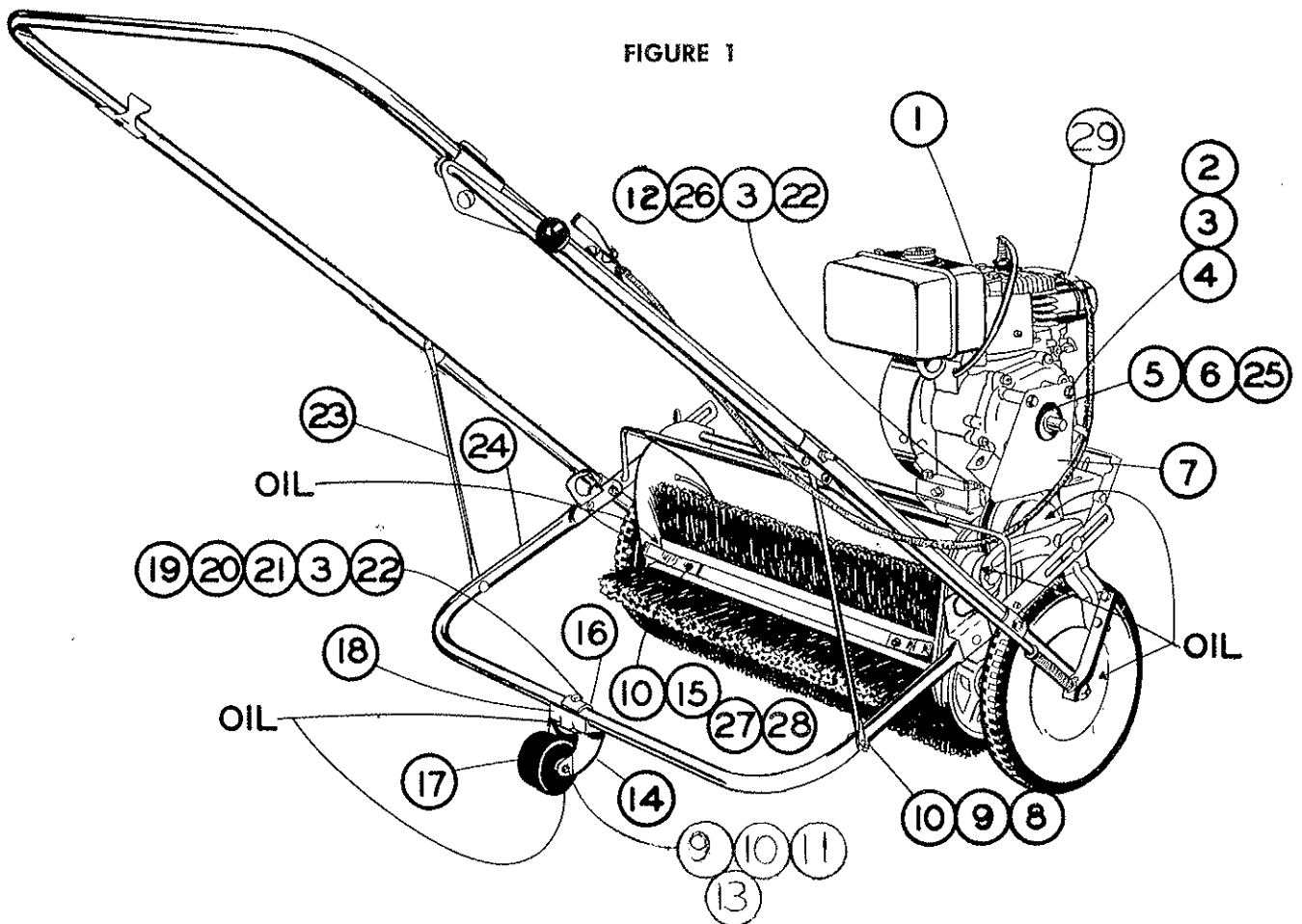

# UPPER FRAME - BASKET AND CLUTCH ASSEMBLY

## Figure 2

Ref. No.	Part No.	Description	Qty. Req'd.	Ref. No.	Part No.	Description	Qty. Req'd.
1	<del>62-95A</del>	Throttle <del>USA 83-25-B-55</del> ...	1	22	*936-716	Lock Washer $\frac{3}{16}$ .....	1
2	<del>*515-10-16</del>	Rd. Hd. Screw 10-24 x 1 ...	2	23	345-716	Hex Jam Nut - Light $\frac{3}{16}$ - 20 N.F. ....	1
3	*936-10	Lock Washer No. 10 .....	4	24	60-66A	Idler Pulley .....	1
4	*335-10	Hex Nut No. 10 - 24 .....	4	25	60-63A	Nylon Bearings .....	2
5	*515-416-28	Rd. Hd. Screw $\frac{1}{4}$ - 20 x 1 $\frac{3}{4}$ ..	2	26	60-23A	Clutch Bracket .....	1
6	*936-416	Lock Washer $\frac{1}{4}$ .....	4	27	60-62A	Roll Pin $\frac{1}{8}$ .....	1
7	*335-416	Hex Nut $\frac{1}{4}$ - 20 .....	4	28	60-46A	Clutch Spring .....	1
8	60-57A	Adjustment Bolt .....	1	29	60-33B	Lower Clutch Rod .....	1
9	<del>351-516-40</del>	Wing Nut $\frac{3}{16}$ - 18 x 2 $\frac{1}{2}$ .....	1	30	60-37D	Clutch Bell Crank .....	1
10	*945-516	Washer SAE $\frac{3}{16}$ .....	3	31	*515-10-8	Rd. Hd. Screw 10 - 24 x $\frac{1}{2}$ ..	2
11	60-21A	Brush Adjusting Bracket ...	2	32	60-32B	Upper Clutch Rod .....	1
12	60-35B	Lower Handle .....	2	33	526-516-12	Truss Hd. Screw $\frac{3}{16}$ - 18 x $\frac{3}{4}$ ..	1
13	59-77A	Clamp .....	4	34	946-816-16	Fiber Washer $\frac{1}{2}$ x 1 .....	1
14	*65-516-28	Hex Hd. Bolt $\frac{3}{16}$ - 18 x 1 $\frac{3}{4}$ ..	2	35	60-28A	Clutch Handle <del>USA 62-27-A</del> ..	1
15	54-227-A	Spacer .....	3	36	55-130A	Plastic Knob .....	1
16	*936-516	Lock Washer $\frac{3}{16}$ .....	3	37	526-516-16	Truss Head Screw $\frac{3}{16}$ - 18 x 1 ..	1
17	*335-516	Hex Nut $\frac{3}{16}$ - 18 .....	3	38	340-516	Hex Jam Nut $\frac{3}{16}$ - 18 .....	2
18	*65-416-12	Hex Head Bolt $\frac{1}{4}$ - 20 x $\frac{3}{4}$ ..	2	39	62-93F	Upper Handle .....	1
19	*60-716-24	Hex Hd. Bolt $\frac{3}{16}$ - 20 x 1 $\frac{1}{2}$ N.F.	1	40	60-52B	Dowel - Basket .....	2
20	*945-716	Washer SAE $\frac{3}{16}$ .....	1	41	62-39D	Basket Assembly Complete ..	1
21	60-64A	Bushing .....	1				

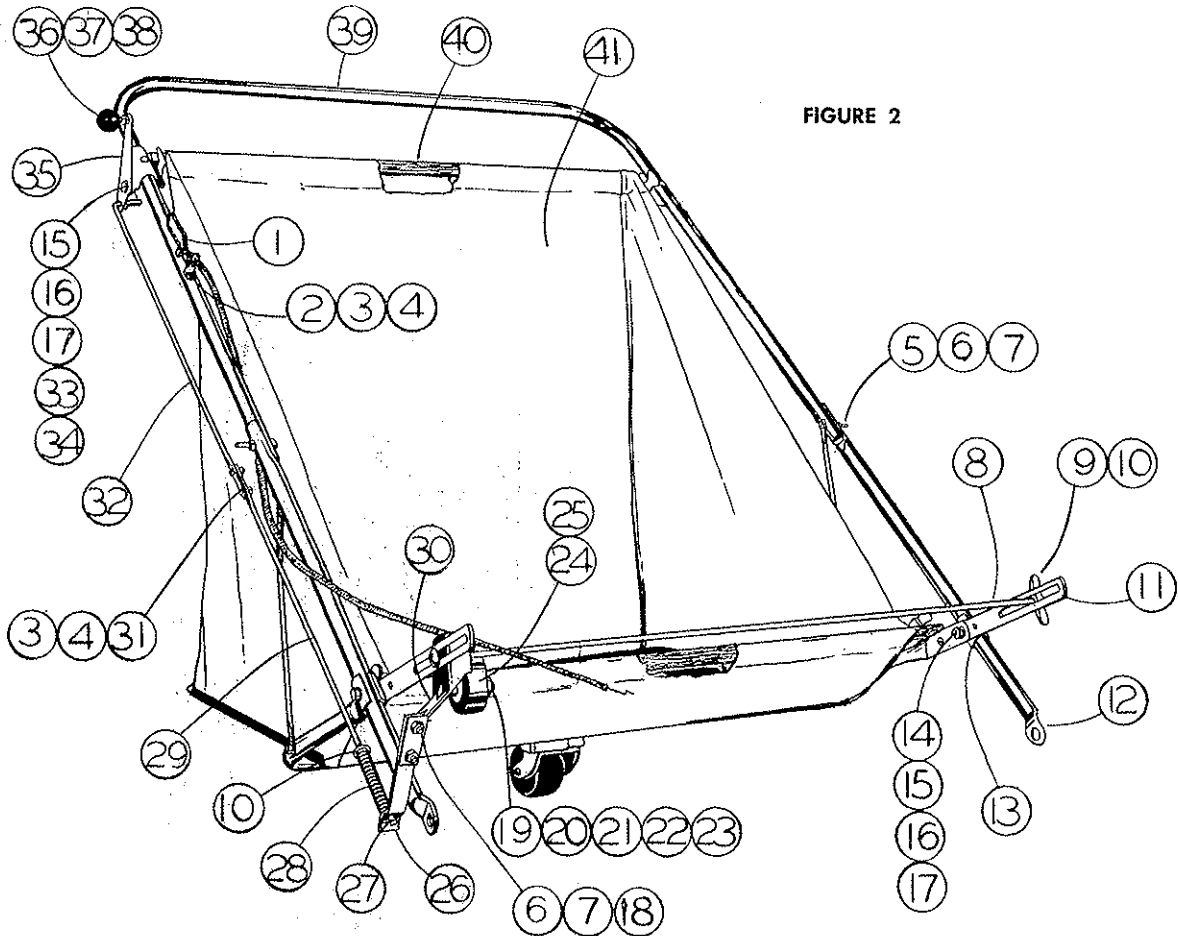

FIGURE 2

# SWEEPER UNIT ASSEMBLY

## Figure 3

Ref. No.	Part No.	Description	Qty. Req'd.	Ref. No.	Part No.	Description	Qty. Req'd.
1	45-25A	Pawl	2	21	60-19D	Right Hand Side Plate	1
2	45-19RA	Pinion - Left Hand	1	22	946-1216-24	Fiber Washer 3/4 x 1 1/2	2
3	49-377C	Wheel	2	23	47-438C	Tire .USA 63-224B	2
4	560-C-516-10	Set Screw 3/8 - 18 x 3/4	6	24	46-81A	Special Washer	2
5	*70-416-12	Carriage Bolt 1/4 - 20 x 3/4	2	25	*380-332-12	Cotter Pin 3/32 x 3/4	2
6	*945-516	Washer SAE 3/8	2	26	946-816-16	Fiber Washer 1/2 x 1	2
7	*351-416-18	Wing Nut 1/4 - 20 x 1 1/8	3	27	45-18-LA	Pinion - Right Hand	1
8	*945-416	Washer SAE 1/4	1	28	50-33A	Special Washer	2
9	*335-416	Hex Nut 1/4 - 20	1	29	55-161A	Special Washer	4
10	60-45C	Rubber Hood Extension	1	30	60-63A	Nylon Bearing	2
11	*515-416-32	Rd. Hd. Screw 1/4 - 20 x 2	1	31	56-121B	2-Step Pulley	1
12	60-50B	Bottom Tie Rod	1	32	60-56A	Upper V Belt 4L220 A Sec.	1
13	60-22B	Hood Clamp	2	33	280-9	Woodruff Key No. 9	1
14	60-24C	Adjustable Engine Brace	1	34	60-49B	Reel Shaft	1
15	49-17A	Brush Bracket	4	35	60-25C	Engine Base Plate	1
16	52-141B	Brush .USA BK-12	Set of 2	36	60-65A	Adjustable Engine Base Pin	1
17	60-20D	Inner Side Plate	1	37	62-42D	Hood	1
18	54-128A	Lower V Belt 4L270 A Sec.	1	38	60-51B	Adjustable Tube	1
19	60-54A	Pulley 5.25 O.D. x 3/8 Bore	1	39	60-18D	Left Hand Side Plate	1
20	59-28A	Nylon Bearing	2	40	63-236B	Rod - Hood Control	2

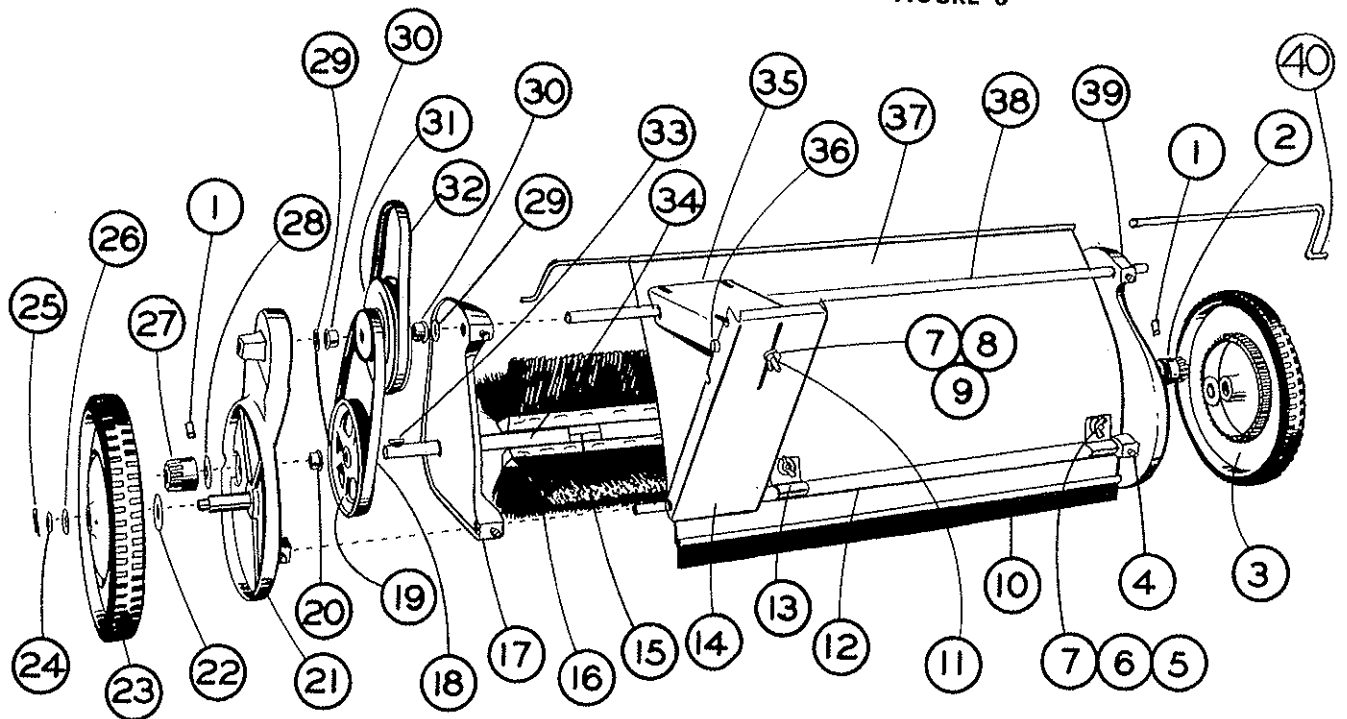

FIGURE 3

R/W  
SA-1583-B

