



Electronic Service Manuals

This electronic document is provided as a service to our customers. We do not create the contents of the information contained in this document. Should you have detailed questions pertaining to the information contained in this document, you may contact Michco, or the manufacturer which provided the original information in this electronic deliverable. Michco's only part in this electronic deliverable was the electronic assembly process. By providing this manual on line we are not guaranteeing parts availability.

You may contact Michco through the following methods:

Phone (517) 484-9312 or (800) 331-3339

2011 N. High St. -- Lansing, Michigan -- 48906

Fax: (517) 484-9836

Email: CustServe@Michco.com

Web site: www.Michco.Com

Parts Web site: www.FloorMachineParts.Com

Order Parts on Line at:

www.FloorMachineParts.Com

Directly to Parts & Service:

By Email: **Shop@Michco.com**

By Fax: (517) 702-2041

By Voice: Use numbers above.

Serving the Cleaning Industry Since 1922

Notice: All copyrighted material remains property of original owners, all trademarks are property of respective owners. Manuals are subject to Manufacturer's reproduction limitations. Originals or reproductions were provided by manufacturers through a request. We make no warranty as to the correctness of information provided in this document and you assume all risk. By placing these manuals on line we are not declaring our corporation to be an manufacturer authorized dealer or provider, please check our web site for authorized manufacturers we represent.

OPERATING INSTRUCTIONS AND PARTS LIST
FOR
HM5728-B HOMEMASTER

Parker

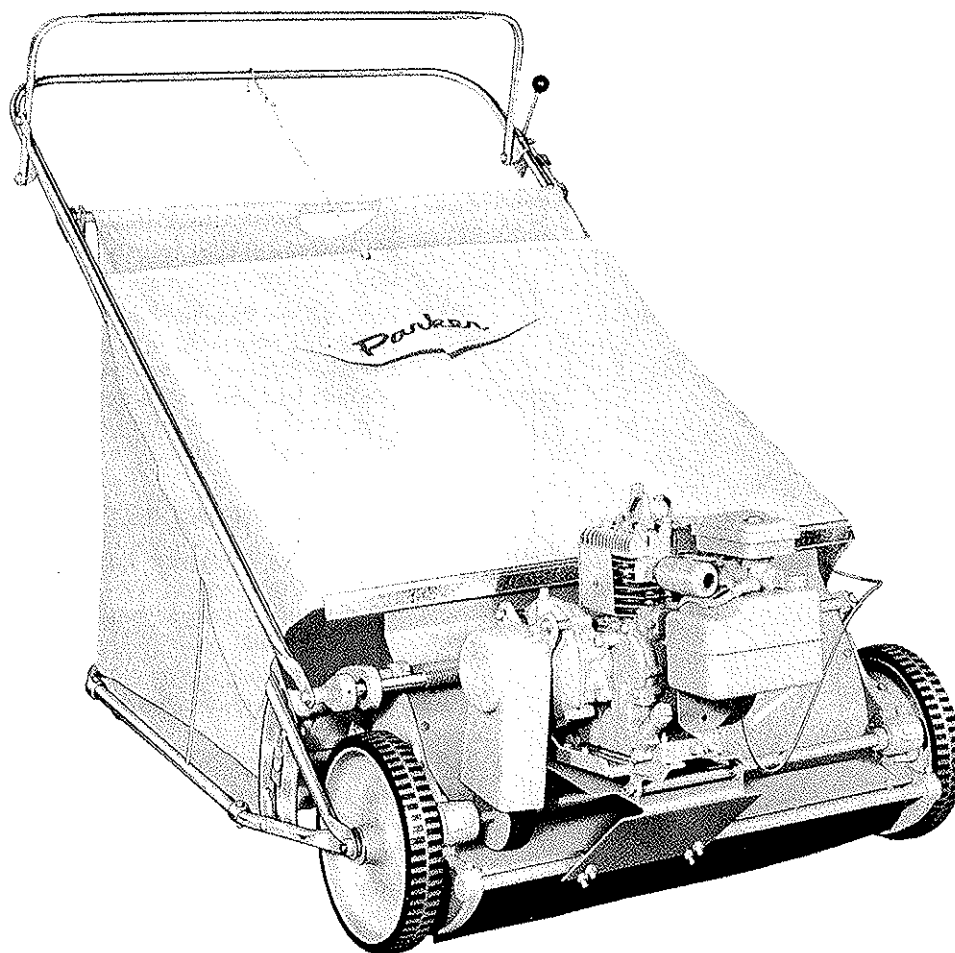
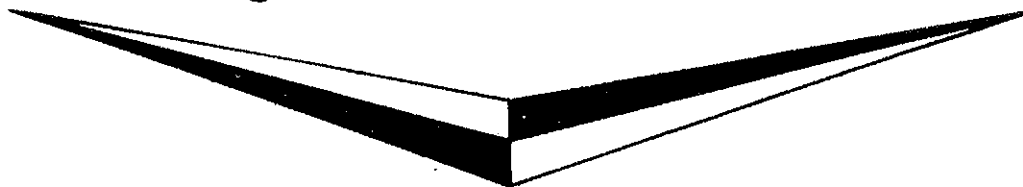

NOTICE: These instructions were written to assist you in assembling your Lawn Sweeper quickly and correctly. Read instructions thoroughly before attempting assembly so that you are familiar with the complete procedure.

PARKER SWEEPER COMPANY

BOX 720

SPRINGFIELD, OHIO

ASSEMBLY INSTRUCTIONS

Your new Parker Homemaster Power Lawn Sweeper comes to you complete in two cartons.

The largest carton contains the sweeper unit, clutch control rod, belt guard with hardware attached, upper handle assembly and a roll package.

The roll package contains the following:

- 1 Wind Apron Assembly ✓
- 1 Basket Assembly ✓
- 1 Spring for Holding Throttle Cable to Handle ✓
- 1 Cloth Bag Containing the following:
 - 1 Two-Groove Pulley with Set Screw ✓
 - 1 Pulley Key $\frac{3}{8} \times \frac{3}{8} \times 1$ ✓
 - 1 Allen Wrench $\frac{1}{8}$ ✓
 - 1 Allen Wrench $\frac{3}{32}$ ✓
 - 4 Engine Mounting Bolts $\frac{3}{8} \times 1\frac{1}{2}$ hex head ✓
 - 4 Lock Washers $\frac{3}{8}$ ✓
 - 4 Hex Nuts $\frac{3}{8}$ ✓

The small carton contains the following:

- 1 Engine
- 1 Engine Manual

To assemble this sweeper, first read the instructions through. After reading, proceed to assemble step-by-step as follows:

1. Remove the sweeper unit from the carton and untie the handle and roll package. Check the parts with the above list.
2. Pull the Handle Assembly back from the Sweeper into its relative position.

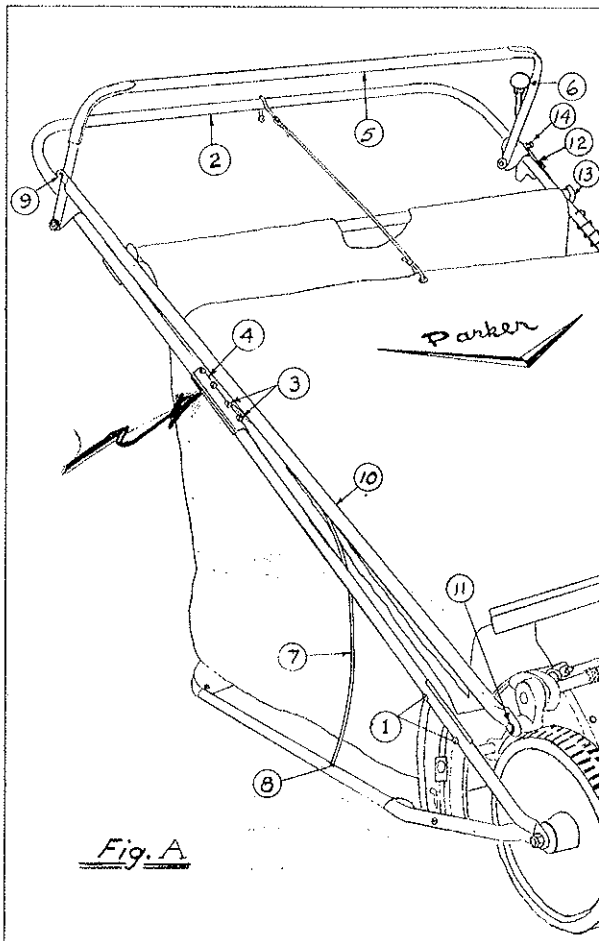

3. Remove the two round head screws which are located at Point 1, Figure A. Do this on each side of Sweeper. *BOLTS + CLAMPS*
4. With the Lower Handle sections in the raised position as shown in Figure A, replace the screws that were removed in Step 3 and tighten. *1/4 BOLTS*
5. Remove the two round head screws from each end of the Upper Handle at Point 4, Figure A, loosen but do not remove the other two screws at each of the Lower Handle clamps located at Point 3, Figure A. *BOLT*
6. Place the ends of the Upper Handle Assembly, Point 2, Figure A, into the Handle Clamps, Point 4, Figure A, being sure that the Clutch Control Bar, Point 5, Figure A, is upwards, and the Throttle Control, Point 6, Figure A, is to the left. Replace the screws that were removed in Step 5, and then tighten all four screws on each side. *1*
7. Place the Handle Support Springs, Point 7, Figure A, by inserting ends of springs into holes located at Point 8, Figure A.
8. Remove the hex head bolt from the Clutch Bar at Point 9, Figure A, the hardware on this bolt is in correct sequence. Place the Clutch Control Rod as shown at Point 10, Figure A, and replace the hex head bolt, spacer and washers on the Clutch Bar in the correct order which is as follows, reading from the handle out to the head of the bolt: first, lock washer; second, flat washer; third, spacer and clutch control rod; fourth, flat washer. Tighten this bolt.
9. Remove the hex head bolt from the Clutch Lever at Point 11, Figure A, and place other end of Clutch Control Rod as shown at Point 11, Figure A, and replace hex head bolt, spacer and washers less the lock washer in the same order as was done in Step 8, and tighten bolt.

ENGINE INSTALLATION

1. Loosen the wing nut which is located on the left side of the sweeper unit. This will loosen the unit so that the sweeper may be adjusted for correct brush height.
2. Adjust the sweeping unit so that the Engine Base Plate is level with the ground, retighten the wing nut.
3. Push the Clutch Control Bar, which is located at Point 5, Figure A, forward so as to raise the Engine Mounting Plate.
4. Insert two of the Engine Mounting Bolts up through the slots at the rear of the Engine Mounting Plate. Then lower the Engine Mounting Plate back to the former position.
5. Place the Engine over the two rear bolts; be sure that the Gas Tank is to the front.
6. Insert the front two Engine Mounting Bolts up through the Mounting Plate and through the hole in the Engine Base. Then place a lock washer over the four bolts and run the hex nuts onto the bolt. Do not tighten these nuts at this time.
7. Place the "V" Pulley on the Engine Shaft with the

Hub away from the Engine. The Pulley should be pushed on the shaft until it is in line with the bottom "V" Pulley and the Key must be back on the Shaft far enough so that the Pulley Set Screw sets down on the Key. Do not tighten the set screw.

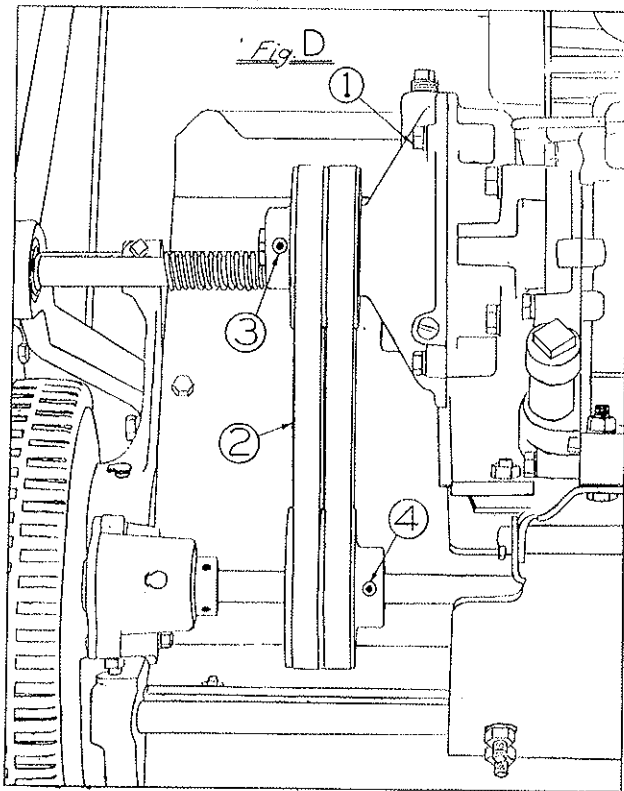

8. Place the Belts over the two "V" Pulleys as shown in Figure D, then raise the Engine as was done in Step 2.

9. Move the Engine forward on the Mounting Plate as far as needed to tighten the Belts. With the Engine forward and the Belts tightened correctly, turn the nuts on the Engine Mounting bolts down tight to hold Engine in place. Now line the Engine Pulley up so that the Belts are vertical from Lower Pulley as shown at Point 2, Figure D, and tighten set screw in Pulley at Point 3, Figure D.

10. Remove the two upper bolts in the Engine Gear Case which are located at Point 1, Figure D. Discard these bolts and with the bolts and spacers that are attached to the Belt Guard (discard the two nuts), mount the Belt Guard to the Gear Case as shown at Point 1, Figure E. Have a lock washer and flat washer between the Guard and the head of the bolts, then one flat washer between the Belt Guard and Spacer. Check at Point 2, Figure E, for equal spacing of Belt at each side of Belt Guard, then tighten the bolts. Now pull Clutch Control Bar, Point 5, Figure A, back to release tension on Belt.

11. Check at Point 12, Figure A, to see that end of Throttle Cable is even with edge of Throttle Clamp and that Clamp is tight.

12. Move the Throttle Handle which is located at Point 6, Figure A, forward as far as it will go. Loosen the Wing Nut and adjust the sweeper unit so that the brushes are as high as they will go.

13. Connect the Throttle to the Engine Carburetor Control and bring the cable down between the Gas Tank and the Fly Wheel Housing and fasten cable to the cable clamp provided. Place the cable retaining clamp over the extended ~~allen set screw~~ ³ which is located on the left side plate at the top Tie Rod junction. See front cover illustration. Place Hex Nut to retain the Cable onto the Set Screw but do not tighten.

14. Remove the Handle Support Spring on the throttle side from the lower hole position and let hang so that it is about 90 degrees to the handle.

15. Lay the spring, that is used for holding the Throttle Cable to the Handle, down beside the sweeper, so that it is straight and free. The spring should be about the same length as the distance is from the hub of the wheel back to within two or three inches of the Rear Caster, or about 30 inches in length.

16. With the spring laying free beside the sweeper measure off about 10 inches to the left from the end that is towards the Rear Caster and with your right hand pick the spring up at the 10-inch mark. Hold the spring in such a manner that the 10-inch end is upwards or about at a right angle to the Handle and Throttle Cable. With the left hand place the Cable along the Handle and into the space that is formed between the upper and lower Handle Clamps. Then at the point where the Handle Support Spring is located, press the spring coils open and over the Handle. Wind the upper or 10-inch section around and over the Handle and Cable; it will come to the end at or near the top Basket Rod Support. Then wind the spring downwards in the same manner; it should come to the end about 2 inches from the Adjusting Plate on the Lower Handle. Tighten the hex nut that retains the Cable Clamp to the side plate.

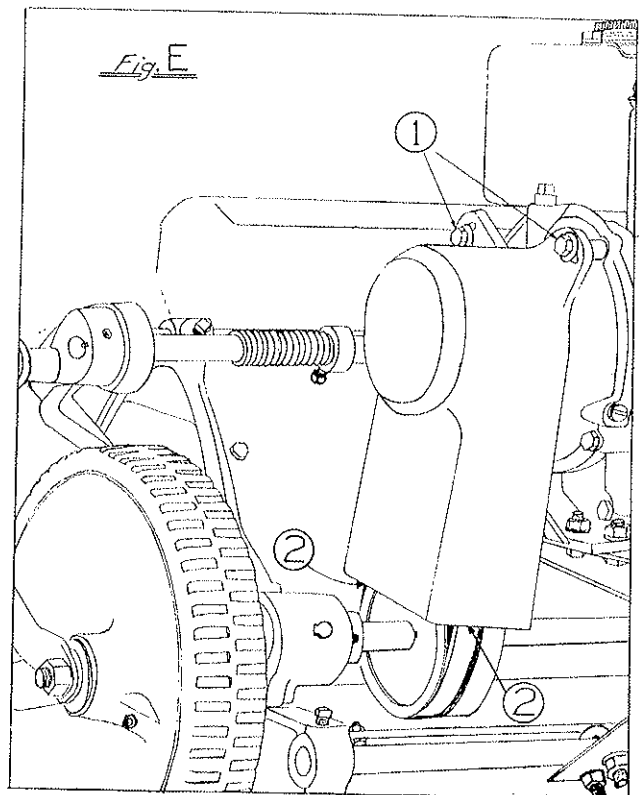

17. Service the Engine as instructed in the Engine Manual.
18. Place the Basket into position as shown illustrated on Front Cover Page, making sure that the Lower Basket Rod Anchor Pins are located into the recessed openings at the top of the Adjusting Plate.
19. Place the Wind Apron into position as shown on Front Cover Page, making sure that the front metal

edge is hooked onto the top of the Hood as shown on front cover, and also that the Wind Apron Hook at the top is fastened over the Sweeper Handle and not over the Clutch Control Bar. When the Basket is to be emptied remove the Wind Apron at the lower end and throw it up and to the rear, over the Handle and Clutch Control Bar rather than over the Engine, to avoid burning the Wind Apron on the hot Engine Exhaust Stack.

OPERATING INSTRUCTIONS

1. Before starting the Engine make sure that the proper grade and amount of oil is in the Engine Crankcase and Gear Case as instructed in the Engine Manual. Make sure that the Engine Stop Switch is not touching the Spark Plug.
2. Inspect the Sweeper to make sure that all the nuts, bolts and set screws are tight. Also that all moving parts are free and do not rub or malfunction.
3. The Sweeper has been lubricated at the factory and will not need any oil at this time. For Sweeper Lubrication refer to the Maintenance Instructions.
4. CAUTION — Pull the Clutch Control Bar which is located at Point 5, Figure A, backwards so that the Sweeper will not move forward when the Engine is started.
5. Start the Engine and adjust as instructed in the Engine Manual.
6. Your new Parker Homemaster Power Sweeper is now ready to sweep for you.

ADJUSTMENTS

BRUSH HEIGHT: To adjust the Sweeper for brush height, place the left hand on the Hood or at the lower part of the Engine and loosen the Wing Nut and raise or lower the machine to the desired height and then tighten the Wing Nut. Always keep the Brushes adjusted as high off of the ground as possible. Adjust them lower, only if good sweeping results require a lower adjustment. This will add to the life of both the brushes and the machine. The Hood is automatically adjusted and in direct relation with any adjustment of the brush height with the new type Hood Extension which permits you to sweep driveways, walks or lawns by simply changing the brush height to the desired need.

CAUTION. The basket fabric on your lawn sweeper is made of "Lumite," a polypropylene filament. This material is far superior to canvas and it won't fade or shrink, is resistant to mildew and rot. While "Lumite" is flame proof it is affected by excessive heat, therefore, to avoid deterioration of the fabric, we caution against unloading the basket over an open fire or allowing the sweeper to stand near fire.

ALWAYS GIVE THE FOLLOWING INFORMATION WHEN ORDERING REPAIR PARTS

If you are unable to obtain parts locally, write to the factory for name of nearest service dealer.

- | | |
|--|----------------------------|
| 1. Part Number and Quantity. | 3. Serial Number |
| 2. Model Number (found on Hood or Side Plate). | (found on Guarantee Card). |

Your unit is right hand (R.H.) or left hand (L.H.) as you stand behind it.

*Standard hardware items may be purchased locally.

BASKET AND WIND APRON: The Wind Apron can be quickly and easily removed when desired. The Basket may be emptied by either picking the sweepings up in the arms and dumping into a container or on a fire, or by removing from the machine and dumping. If dumping from the basket direct onto a fire, avoid getting the basket or yourself too near the flames.

MAINTENANCE

BRUSHES: If the brushes should become bent or deformed from continual use, wet thoroughly with water and comb out straight with the fingers. In severe cases, remove the brushes and reverse them by turning end-for-end. Remember to keep your brushes adjusted as high as good sweeping results will permit.

LUBRICATION: About every ten hours of operation all moving parts should be oiled with SAE 20 or 30 oil. The two places in each side plate and the one in each bearing housing on the jack shaft oils the pinion and wheel gears. In the opening at each end of the brush oil the reel shaft bearings. This will insure good service and maximum life for your machine.

STORAGE: Clean and oil the Sweeper before winter storage. Also drain the gasoline from the tank. If desired to conserve space, the Sweeper may be hung on a wall by removing the handle support springs from the holes in the lower frame, and collapsing the basket and facing the rollers to the wall. If this is done the oil must be drained from the crankcase and gear case also.

To make valid your guarantee, make certain you have returned your Serial Identification Card.

Contact your nearest Engine Dealer for Engine Service and Parts.

HOMEMASTER POWER LAWN SWEEPER	SIZE 28"	PRODUCTION YEAR 1958	MODEL No. HM-5728
--	---------------------	---------------------------------	------------------------------

**SA-1583-B Pinion Kit
(Contains 1 L.H. + 1 R.H. Pinions
& Pawls)*

REF. No.	PART No.	QTY. PER UNIT	DESCRIPTION
1	65-516-12	4	Hex Hd. Bolt 3/8-18 x 3/4
2	945-516	15	Plain Washer 3/8
3	54-227-A	2	Spacer
4	936-516	21	Internal Tooth Lock Washer 3/8
5	65-516-16	7	Hex Hd. Bolt 3/8-18 x 1"
6	53-209-A	2	Spacer
7	57-182-A	1	Clutch Bar Bracket
8	515-416-20	16	Round Hd. Screw 1/4-20 x 1 1/4
9	335-516	17	Hex Nut 3/8-18
10	936-416	25	Internal Tooth Lock Washer 1/4
11	335-416	40	Hex Nut 1/4-20
12	57-168-B	1	Clutch Rod
13	57-149-C	1	Clutch Bar Sub Assembly
14	340-516	2	Hex Jam Nut 3/8-18
15	57-147-B	1	Throttle Bracket Assembly
16	515-416-B	4	Round Hd. Screw 1/4-20 x 1 1/4
17	57-183-A	1	Clamp
18	55-156-A	2	Special Washer <i>R/W 82-138-B-2</i>
19	57-144-B	1	Handle Assembly
20	55-130-A	1	Bell Knob
21	335-8	1	Hex Nut No. 8-32
22	515-8-8	1	Round Head Screw No. 8-32 x 1/2
23	53-165-A	1	Cup Spring Washer
24	55-132-A	1	Throttle Spacer
25	30-82-054	1	Wire
26	20-78-6	1	Cable
27	54-209-A	1	Hook
28	49-295-A-6	1	Elastic Cord 26" Long
29	55-105-C	1	Canvas Wind Apron
30	53-09-B	1	Top Basket Rod
31	54-162-A	1	Spiral Cable Clip
32	55-162-C	1	Upper Handle
33	53-49-B	2	Handle Lower
34	53-40-B	1	L.H. Handle Support Spring
35	53-05-C	2	Adjusting Plate
36	515-416-16	4	Round Head Screw 1/4-20 x 1
37	53-38-D	1	Canvas Basket
38	53-45-B	1	Bottom Basket Rod
39	53-28-A	1	Adjusting Bolt
40	53-18-A	2	Spacer Nut
41	57-136-A	2	Stop Bracket
42	53-08-A	1	Spacer Adjusting Tube
43	351-516-10	1	Wing Nut (3/8-18 x 2 1/2)
44	57-173-A	1	Briggs & Stratton Engine 6.1
45	57-174-A	1	V Pulley
46	48-277-A	1	Key 3/8 x 3/8 x 1
47	564-C-516-4	1	Allen Head Set Screw 3/8-18 x 1/4
48	65-416-32	3	Hex Head Bolt 1/2-20 x 2
49	945-416	7	Plain Washer 1/2
50	57-150-D	1	Belt Guard
51	55-160-A	2	Belt Guard Spacer
52	49-98-A	1	V Belt
53	53-39-C	1	Aux. Basket Support
54	65-516-20	1	Hex Head Bolt 3/8-18 x 1 1/4
55	57-135-B	1	Lever
56	564-C-416-6	1	Allen Hd. Set Screw 1/4-20 x 3/8
57	280-9	2	Woodruff Key No. 9
58	65-416-20	1	Hex Head Bolt 1/2-20 x 1 1/4
59	57-130-C	1	Bearing Bracket
60	564-C-516-6	1	Allen Head Set Screw 3/8-18 x 3/8
61	55-118-A	4	Bearing
62	57-156-B	1	Spring
63	56-53-A	1	Collar
64	560-C-516-8	1	Square Hd. Set Screw 3/8-18 x 1/4
65	57-170-B	1	Cam Shaft
66	57-179-A	1	Roll Pin
67	57-152-A	1	Cam
68	55-161-A	2	Special Washer
69	57-97-A	1	Roll Pin

REF. No.	PART No.	QTY. PER UNIT	DESCRIPTION
70	51-12-A	1	Bearing
71	57-158-A	1	Spacer
72	70-516-20	2	Carriage Bolts 3/8-18 x 1 1/4
73	57-138-E	1	Engine Mounting Bracket
74	53-139-A	2	"U" Bolt
75	57-151-C	1	Clutch Bracket
76	57-184-A	1	Spring
77	57-137-C	1	Engine Mounting Plate
78	65-516-24	4	Hex Head Bolts 3/8-18 x 1 1/4
79	57-153-B	1	Top Tie Rod
80	53-65-A	1	Roll Pin <i>R/W 71-06-A</i>
81	57-157-A	1	Pivot Pin
82	380-332-12	1	Cotter Pin 1/2 x 3/4
83	57-19-B	1	Tubular Spacer
84	53-178-B	1	Tube Adjusting
85	505-416-8	8	Flat Head Screw 3/8-18 x 3/4
86	56-94-B	4	Pinion Cover <i>R/W 80-01-B</i>
87	946-1016-16	4	Fiber Washer
88	56-19-LG	2	Pinion Gear L.H. <i>see above</i>
89	45-25-A	4	Pawl <i>see above</i>
90	50-33-A	4	Special Washer
91	55-114-RD	2	Bearing Housing
92	57-123-A	1	Bearing
93	57-166-A	1	V Pulley
94	57-159-B	1	Jack Shaft
95	57-154-A	1	Front Tie Rod
96	56-18-RC	2	Pinion Gear R.H. <i>see above</i>
97	367-816	2	Hex Jam Nut 1/2-20 NF
98	57-162-A	2	Special Washer
99	57-23-C	2	Tire <i>R/W 78-124-C</i>
100	57-122-C	2	Wheel
101	57-155-A	2	Axle
102	57-162-A	2	Special Washer
103	560-C-516-10	5	Sq. Hd. Set Screws 3/8-18 x 3/8
104	57-138-LE	1	Side Plate L.H.
105	564-C-516-12	1	Allen Head Set Screw 3/8-18 x 3/4
106	47-229-A	1	Cable Clip
107	49-296-A	1	1/2 Allen Wrench
108	325-1016	2	Hex Nut 3/8-18 NF
109	53-176-D	2	Reel Guard
110	57-160-B	1	Reel Shaft
111	57-187-B	1	Brush Strip Assembly (Set of 2) <i>R/W BK-9</i>
112	49-17-A	4	Brush Brackets (Set of 2)
113	515-416-28	4	Round Head Screw 1/4-20 x 1 1/4
114	57-134-RE	1	Side Plate R.H.
115	57-190-B	1	Hood Extension Assembly
116	58-02-B	1	Metal Extension
117	57-139-D	1	Hood
118	65-416-12	4	Hex Head Bolts 1/2-20 x 3/8
119	45-70-A	2	Rubber Roller
120	45-71-A	2	Bushing
121	515-416-44	2	Round Head Screw 1/4-20 x 2 1/4
122	47-218-B	2	Caster Fork
123	47-215-A	2	Cone
124	45-22-A	2	Bearing and Retainer
125	47-214-A	2	Bearing Race
126	47-216-A	2	Retainer Swivel
127	53-02-B	2	Caster Mounting Plate
128	526-516-20	2	Truss Head Screw 3/8-18 x 1 1/4
129	53-44-B	4	Handle Clamp
130	53-43-B	1	R.H. Handle Support Spring
131	49-426-A	1	1/2 Hex Allen Wrench

WIND APRON

55-104-C	1	Wind Apron Complete
55-105-C	1	Canvas
54-209-A	1	Hook
49-295-A-4	1	Elastic Cord

HM-5728

PARKER SWEEPER COMPANY

PARTS LIST for

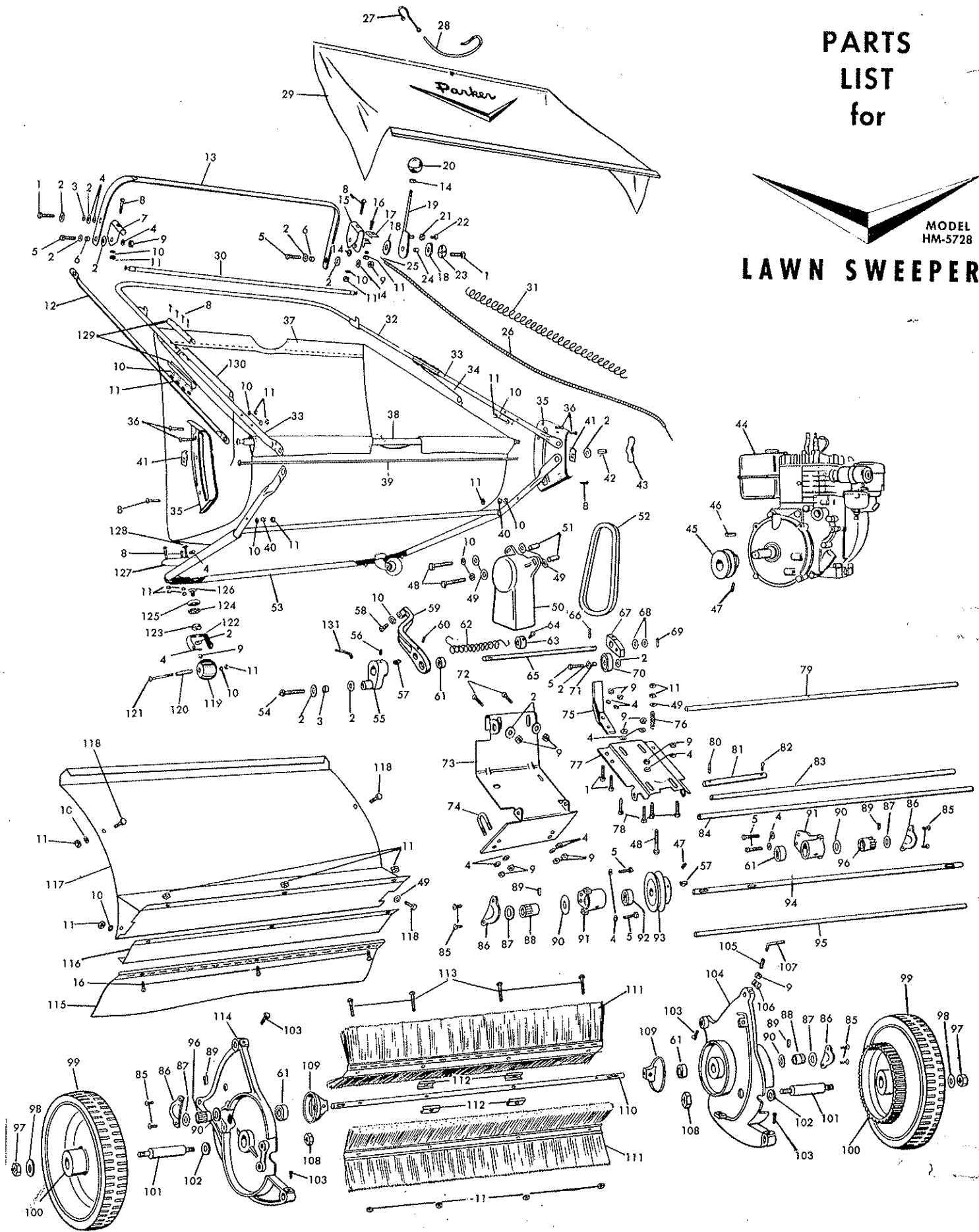

Parts with description are listed in numerical order on opposite page.



MODEL
HM-5728-B

LAWN SWEEPER

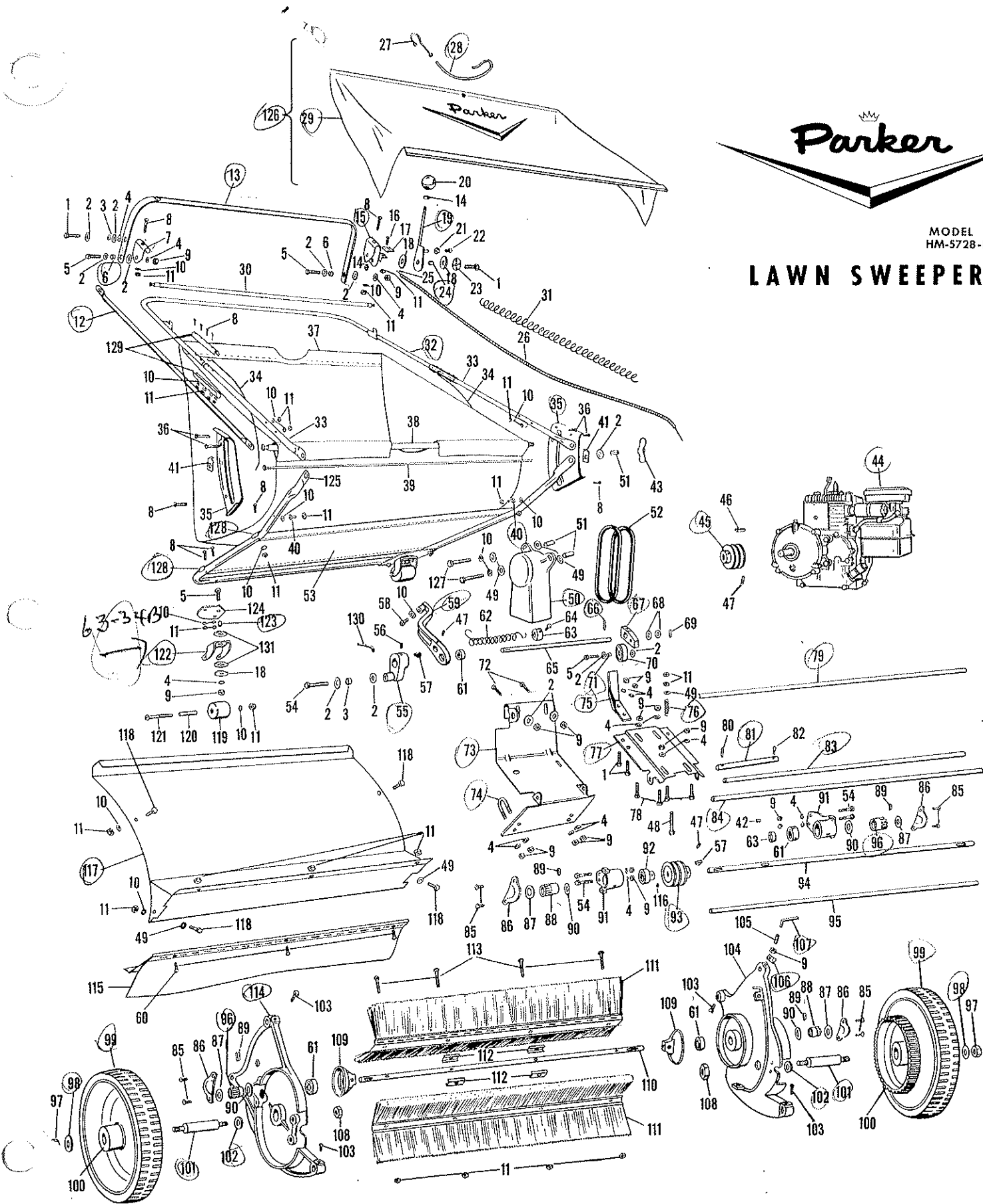

PARTS LIST

Ref. No.	Part No.	Description	Req. No.	Ref. No.	Part No.	Description	Req. No.
1	*65-516-12	Bolt — Hex Head $\frac{5}{16}$ - 18 x $\frac{3}{4}$	4	67	57-152-A	Cam	1
2	*945-516	SAE Flat Washer $\frac{5}{16}$	13	68	55-161-A	Washer — Special	2
3	54-227-A	Spacer	2	69	57-97-A	Roll Pin	1
4	*936-516	Lock Washer — Internal Tooth $\frac{5}{16}$	19	70	58-147-A	Bearing	1
5	*65-516-16	Bolt — Hex Head $\frac{5}{16}$ - 18 x 1	5	71	57-158-A	Spacer	1
6	53-209-A	Spacer	2	72	*70-516-20	Bolt — Carriage $\frac{5}{16}$ - 18 x $1\frac{1}{4}$	2
7	57-182-A	Bracket — Clutch Bar	1	73	57-138-E	Bracket — Engine Mounting	1
8	*515-416-20	Screw — Round Head $\frac{1}{4}$ - 20 x $1\frac{1}{4}$	18	74	53-139-A	"U" Bolt	2
9	*335-516	Nut — Hex $\frac{5}{16}$ - 18	21	75	57-151-C	Bracket — Clutch	1
10	*936-416	Lock Washer — Internal Tooth $\frac{1}{4}$	31	76	57-184-A	Spring	1
11	*335-416	Nut — Hex $\frac{1}{4}$ - 20	38	77	57-137-C	Plate — Engine Mounting	1
12	57-168-B	Clutch Rod	1	78	*65-516-24	Bolt — Hex Head $\frac{5}{16}$ - 18 x $1\frac{1}{2}$	4
13	57-149-C	Clutch Bar Sub Assembly	1	79	57-153-B	Rod — Top Tie	1
14	*340-516	Nut — Hex Jam $\frac{5}{16}$ - 18	2	80	53-65-A	Roll Pin	1
15	57-147-B	Bracket — Throttle Assembly	1	81	57-157-A	Pivot Pin	1
16	*515-416-8	Screw — Round Head $\frac{1}{4}$ - 20 x $\frac{1}{2}$	1	82	*380-332-16	Cotter Pin $\frac{3}{32}$ x 1	1
17	57-183-A	Clamp	1	83	57-19-B	Spacer — Tubular	1
18	55-156-A	Washer — Special	4	84	53-178-B	Tube — Adjusting	1
19	57-144-B	Handle — Throttle Assembly	1	85	*505-416-8	Screw — Flat Head $\frac{5}{16}$ - 18 x $\frac{1}{2}$	8
20	55-130-A	Ball Knob	1	86	56-94-B	Cover — Pinion	4
21	*335-8	Nut — Hex No. 8-32	1	87	946-1016-16	Washer — Fiber	4
22	*515-8-8	Screw — Round Head No. 8-32 x $\frac{1}{2}$	1	88	63-19-LC	Pinion Gear L.H.	2
23	53-165-A	Washer — Cup Spring	1	89	45-25-A	Pawl	4
24	55-132-A	Spacer — Throttle	1	90	50-33-A	Washer — Special	4
25	30-82-.054	Wire	1	91	55-114-D	Housing — Bearing	2
26	20-78-6	Cable	1	92	58-141-A	Bearing	1
27	54-209-A	Hook	1	93	60-17-A	"V" Pulley (Jack Shaft)	1
28	49-295-A-6	Elastic Cord 26" Long	1	94	57-159-B	Jack Shaft	1
29	55-105-C	Canvas — Wind Apron	1	95	57-154-A	Rod — Front Tie	1
30	53-09-B	Rod — Top Basket	1	96	63-18-RC	Pinion Gear R.H.	2
31	54-162-A	Spiral Cable Clip	1	97	367-816	Nut — Hex Jam $\frac{1}{2}$ - 20 N.F.	2
32	55-162-C	Handle — Upper	1	98	67-163-A	Washer — Special	2
33	53-49-B	Handle — Lower	2	99	57-23-C	Tire 78-124C	2
34	53-43-B	Spring — Handle Support	2	100	57-132-C	Wheel	2
35	53-05-C	Plate — Adjusting	2	101	57-155-A	Axle	2
36	*515-416-16	Screw — Round Head $\frac{1}{4}$ - 20 x 1	4	102	57-162-A	Washer — Special	2
37	53-38-D	Basket	1	103	560-C-516-10	Set Screw—Square Head $\frac{5}{16}$ - 18 x $\frac{5}{8}$	5
38	53-45-B	Rod — Bottom Basket	1	104	57-133-LE	Side Plate L.H.	1
39	53-28-A	Bolt — Adjusting	1	105	564-C-516-12	Set Screw — Allen Head $\frac{5}{16}$ - 18 x $\frac{3}{4}$	1
40	53-18-A	Spacer Nut	2	106	47-229-A	Cable Clip	1
41	57-136-A	Bracket — Stop	2	107	49-296-A	$\frac{5}{16}$ Hex Allen Wrench	1
42	564-C-516-4	Set Screw — Allen Head $\frac{5}{16}$ - 18 x $\frac{1}{4}$	1	108	*325-1016	Nut — Hex $\frac{5}{8}$ - 18 N.F.	2
43	351-516-40	Wing Nut $\frac{5}{16}$ - 18 x $2\frac{1}{2}$ Wing Span	1	109	53-176-D	Guard — Reel	2
44	57-173-A	Engine — Briggs & Stratton 6:1	1	110	57-160-B	Reel Shaft	1
45	60-16-A	"V" Pulley (Engine)	1	111	57-187-B	Brush Strip Assembly (Set of 2)	1
46	48-277-A	Key $\frac{3}{16}$ x $\frac{3}{8}$ x 1"	1	112	49-17-A	Bracket — Brush	4
47	564-C-516-6	Set Screw — Allen Head $\frac{5}{16}$ - 18 x $\frac{3}{8}$	3	113	*515-416-28	Screw — Round Head $\frac{1}{4}$ - 20 x $1\frac{3}{4}$	4
48	*65-416-32	Bolt — Hex Head $\frac{1}{4}$ - 20 x 2	1	114	57-134-RE	Side Plate R.H.	1
49	*945-416	SAE Flat Washer $\frac{1}{4}$	7	115	58-10-C	Hood Extension Assembly	1
50	57-150-D	Guard — Belt	1	116	563-C-1032-3	Set Screw—Allen Hd. No. 10-32 x $\frac{3}{16}$	2
51	59-14-A	Spacer	3	117	59-15-D	Hood	1
52	47-287-A	"V" Belt (Matched Sets)	2	118	*65-416-12	Bolt — Hex Head $\frac{1}{4}$ - 20 x $\frac{3}{4}$	4
53	63-50-D	Support — Aux. Basket	1	119	63-52-B	Roller — Rubber	2
54	*65-516-20	Bolt — Hex Head $\frac{5}{16}$ - 18 x $1\frac{1}{4}$	5	120	45-71-A	Bushing	2
55	57-135-B	Lever	1	121	*515-416-44	Screw — Round Head $\frac{1}{4}$ - 20 x $2\frac{3}{4}$	2
56	564-C-416-6	Set Screw — Allen Head $\frac{1}{4}$ - 20 x $\frac{3}{8}$	1	122	47-218-B	Fork — Caster	2
57	280-9	Woodruff Key No. 9	2	123	63-48-A	Spacer	2
58	*65-416-20	Bolt — Hex Head $\frac{1}{4}$ - 20 x $1\frac{1}{4}$	1	124	53-02-B	Plate — Caster Mounting	2
59	57-130-C	Bracket — Bearing	1	125	53-37-C	Frame — Basket Bottom	1
60	*515-416-6	Screw — Round Head $\frac{1}{4}$ - 20 x $\frac{3}{8}$	3	126	57-189-C	Wind Apron Complete	1
61	55-118-A	Bearing	4	127	*65-416-40	Bolt — Hex Head $\frac{1}{4}$ - 20 x $2\frac{1}{2}$	2
62	57-156-B	Spring	1	128	63-51-B	Cross Tube	2
63	56-53-A	Collar	2	129	53-44-B	Clamp — Handle	4
64	560-C-516-8	Set Screw—Square Head $\frac{5}{16}$ - 18 x $\frac{1}{2}$	1	130	49-426-A	$\frac{1}{8}$ Hex Allen Wrench	1
65	57-170-B	Cam Shaft	1	131	63-29-A	Washer — Special	4
66	57-179-A	Roll Pin	1				

HOMEMASTER POWER LAWN SWEEPER	SIZE 28"	PRODUCTION YEAR 1963	MODEL No. HM-5728-B
--	---------------------	---------------------------------	--------------------------------

PARTS LIST

Ref. No.	Part No.	Qty. Per Unit	Description	Ref. No.	Part No.	Qty. Per Unit	Description
1	*65-516-12	4	Bolt — Hex Head $\frac{5}{16}$ - 18 x $\frac{3}{4}$	67	57-152-A	1	Cam
2	*945-516	13	SAE Flat Washer $\frac{5}{16}$	68	55-161-A	2	Washer — Special
3	54-227-A	2	Spacer	69	57-97-A	1	Roll Pin
4	*936-516	19	Lock Washer — Internal Tooth $\frac{5}{16}$	70	58-147-A	1	Bearing
5	*65-516-16	5	Bolt — Hex Head $\frac{5}{16}$ - 18 x 1	71	57-158-A	1	Spacer
6	53-209-A	2	Spacer	72	*70-516-20	2	Bolt — Carriage $\frac{5}{16}$ - 18 x 1 $\frac{1}{4}$
7	57-182-A	1	Bracket — Clutch Bar	73	57-138-E	1	Bracket — Engine Mounting
8	*515-416-20	18	Screw — Round Head $\frac{1}{4}$ - 20 x 1 $\frac{1}{4}$	74	53-139-A	2	"U" Bolt
9	*335-516	21	Nut — Hex $\frac{5}{16}$ - 18	75	57-151-C	1	Bracket — Clutch
10	*936-416	31	Lock Washer — Internal Tooth $\frac{1}{4}$	76	57-184-A	1	Spring
11	*335-416	38	Nut — Hex $\frac{1}{4}$ - 20	77	57-137-C	1	Plate — Engine Mounting
12	57-168-B	1	Clutch Rod	78	*65-516-24	4	Bolt — Hex Head $\frac{5}{16}$ - 18 x 1 $\frac{1}{2}$
13	57-149-C	1	Clutch Bar Sub-Assembly	79	57-153-B	1	Rod — Top Tie
14	*340-516	2	Nut — Hex Jam $\frac{5}{16}$ - 18	80	53-65-A	1	Roll Pin <i>R/W 7606-A</i>
15	57-147-B	1	Bracket — Throttle Assembly	81	57-157-A	1	Pivot Pin
16	*515-416-8	1	Screw — Round Head $\frac{1}{4}$ - 20 x $\frac{1}{2}$	82	*380-332-16	1	Cotter Pin $\frac{3}{32}$ x 1
17	57-183-A	1	Clamp	83	57-19-B	1	Spacer — Tubular
18	55-156-A	4	Washer — Special	84	53-176-B	1	Tube — Adjusting
19	57-144-B	1	Handle — Throttle Assembly	85	*505-416-8	8	Screw — Flat Head $\frac{5}{16}$ - 18 x $\frac{1}{2}$
20	55-130-A	1	Ball Knob	86	56-94-B	4	Cover — Pinion <i>R/W 80-01-B</i>
21	*335-0	1	Nut — Hex No. 8-32	87	946-1016-16	4	Washer — Fiber
22	*515-8-8	1	Screw — Round Head No. 8-32 x $\frac{1}{2}$	88	63-19-C	2	Pinion Gear L.H. <i>R/W 45-19-LA</i>
23	53-165-A	1	Washer — Cup Spring	89	45-25-A	4	Pawl
24	55-132-A	1	Spacer — Throttle	90	50-33-A	4	Washer — Special
25	30-82-054	1	Wire	91	55-114-D	2	Housing — Bearing
26	20-78-6	1	Cable	92	58-141-A	1	Bearing
27	54-209-A	1	Hook	93	60-17-A	1	"V" Pulley (Jack Shaft)
28	49-295-A-6	1	Elastic Cord — 26" Long	94	57-159-B	1	Jack Shaft
29	55-105-C	1	Canvas — Wind Apron	95	57-154-A	1	Rod — Front Tie
30	53-09-B	1	Rod — Top Basket	96	63-18-RC	2	Pinion Gear R.H.
31	54-162-A	1	Spiral Cable Clip	97	367-016	2	Nut — Hex Jam $\frac{1}{2}$ - 20-N.F.
32	55-162-C	1	Handle — Upper	98	67-163-A	2	Washer — Special
33	53-49-B	2	Handle — Lower	99	57-23-C	2	Tire <i>78-124-C</i>
34	53-43-B	2	Spring — Handle Support	100	57-132-C	2	Wheel
35	53-05-C	2	Plate — Adjusting	101	57-155-A	2	Axle
36	*515-416-16	4	Screw — Round Head $\frac{1}{4}$ - 20 x 1	102	57-162-A	2	Washer — Special
37	53-38-D	1	Basket	103	560-C-516-10	5	Set Screw — Square Head $\frac{5}{16}$ - 18 x $\frac{5}{8}$
38	53-45-B	1	Rod — Bottom Basket	104	57-133-E	1	Side Plate L.H.
39	53-28-A	1	Bolt — Adjusting	105	564-C-516-12	1	Set Screw — Allen Head $\frac{5}{16}$ - 18 x $\frac{3}{4}$
40	53-18-A	2	Spacer — Nut	106	47-229-A	1	Cable Clip
41	57-136-A	2	Bracket — Stop	107	49-296-A	1	$\frac{1}{2}$ Hex Allen Wrench
42	564-C-516-4	1	Set Screw — Allen Head $\frac{5}{16}$ - 18 x $\frac{1}{4}$	108	*325-1016	2	Nut — Hex $\frac{3}{8}$ - 18-N.F.
43	351-516-40	1	Wing Nut $\frac{5}{16}$ - 18 x 2 $\frac{1}{2}$ Wing Span	109	53-176-D	2	Guard — Reel
44	57-173-A	1	Engine — Briggs & Stratton 6.1	110	57-160-B	1	Reel Shaft
45	60-16-A	1	"V" Pulley (Engine)	111	57-187-B <i>BR-9</i>	1	Brush Strip Assembly (Set of 2)
46	48-277-A	1	Key $\frac{3}{8}$ x $\frac{3}{16}$ x 1"	112	49-17-A	4	Bracket — Brush
47	564-C-516-6	3	Set Screw — Allen Head $\frac{5}{16}$ - 18 x $\frac{3}{8}$	113	*515-416-28	4	Screw — Round Head $\frac{1}{4}$ - 20 x 1 $\frac{3}{4}$
48	*65-416-32	1	Bolt — Hex Head $\frac{1}{4}$ - 20 x 2	114	57-134-RE	1	Side Plate R.H.
49	*945-416	7	SAE Flat Washer $\frac{1}{4}$	115	58-10-C	1	Hood Extension Assembly
50	57-150-D	1	Guard — Belt	116	563-C-1032-3	2	Set Screw — Allen Hd. No. 10-32 x $\frac{5}{16}$
51	59-14-A	3	Spacer	117	59-15-D	1	Head
52	47-287-A	2	"V" Belt (Matched Sets)	118	*65-416-12	4	Bolt — Hex Head $\frac{1}{4}$ - 20 x $\frac{3}{4}$
53	63-50-D	1	Support — Aux. Basket	119	63-52-B	2	Roller — Rubber
54	*65-516-20	5	Bolt — Hex Head $\frac{5}{16}$ - 18 x 1 $\frac{1}{4}$	120	45-71-A	2	Bushing
55	57-135-B	1	Lever	121	*515-416-44	2	Screw — Round Head $\frac{1}{4}$ - 20 x 2 $\frac{3}{4}$
56	564-C-416-6	1	Set Screw — Allen Head $\frac{1}{4}$ - 20 x $\frac{3}{8}$	122	47-218-B	2	Fork — Caster
57	280-9	2	Woodruff Key No. 9	123	63-48-A	2	Spacer
58	*65-416-20	1	Bolt — Hex Head $\frac{1}{4}$ - 20 x 1 $\frac{1}{4}$	124	53-02-B	2	Plate — Caster Mounting
59	57-130-C	1	Bracket — Bearing	125	53-37-C	1	Frame — Basket Bottom
60	*515-416-6	3	Screw — Round Head $\frac{1}{4}$ - 20 x $\frac{3}{8}$	126	57-189-C	1	Wind Apron Complete
61	55-118-A	4	Bearing	127	*65-416-40	2	Bolt — Hex Head $\frac{1}{4}$ - 20 x 2 $\frac{1}{2}$
62	57-156-B	1	Spring	128	63-51-B	2	Cross Tube
63	56-53-A	2	Collar	129	53-44-B	4	Clamp — Handle
64	560-C-516-8	1	Set Screw — Square Head $\frac{5}{16}$ - 18 x $\frac{1}{2}$	130	49-426-A	1	$\frac{1}{2}$ Hex Allen Wrench
65	57-170-B	1	Cam Shaft	131	63-29-A	4	Washer — Special
66	57-179-A	1	Roll Pin	132	63-53-B	2	Caster — Assembly

HOMEMASTER	SIZE	PRODUCTION YEAR	MODEL No.
POWER LAWN SWEEPER	28"	1960	HM-5728-A

REF. No.	PART No.	QTY. PER UNIT	DESCRIPTION	REF. No.	PART No.	QTY. PER UNIT	DESCRIPTION
1	65-516-12	4	Hex Hd. Bolt 3/8-18 x 3/4	20	58-147-A	1	Bearing
2	945-516	15	Plain Washer 3/8	21	57-158-A	1	Spacer
3	54-227-A	2	Spacer	72	70-516-20	2	Carriage Bolts 3/8-18 x 1 1/4
4	936-516	21	Internal Tooth Lock Washer 3/8	73	57-138-E	1	Engine Mounting Bracket
5	65-516-16	3	Hex Hd. Bolt 3/8-18 x 1"	74	53-139-A	2	"U" Bolt
6	53-209-A	2	Spacer	75	57-151-C	1	Clutch Bracket
7	57-182-A	1	Clutch Bar Bracket	76	57-184-A	1	Spring
8	515-416-20	12	Round Hd. Screw 1/4-20 x 1 1/4	77	57-137-C	1	Engine Mounting Plate
9	335-516	21	Hex Nut 3/8-18	78	65-516-24	4	Hex Head Bolts 3/8-18 x 1 1/2
10	936-416	24	Internal Tooth Lock Washer 1/4	79	57-153-B	1	Top Tie Rod
11	335-416	32	Hex Nut 1/4-20	80	53-65-A	1	Roll Pin R/W 71-06-A
12	57-149-B	1	Clutch Rod	81	57-157-A	1	Pivot Pin
13	57-149-C	1	Clutch Bar Sub. Assembly	82	380-332-16	1	Cotter Pin 3/8 x 1
14	340-516	2	Hex Jam Nut 3/8-18	83	57-19-B	1	Tubular Spacer
15	57-147-B	1	Throttle Bracket Assembly	84	53-178-B	1	Tube Adjusting
16	515-416-8	1	Round Hd. Screw 1/4-20 x 1/2	85	505-416-B	8	Flat Head Screw 3/8-18 x 1/2
17	57-183-A	1	Clamp	86	56-94-B	4	Pinion Cover R/W 80-01-B
18	50-230-A	2	Special Washer	87	946-1016-16	4	Fiber Washer
19	57-144-B	1	Handle Assembly	88	MS# 19-LC	2	Pinion Gear L.H.
20	55-130-A	1	Bolt Knob	89	45-25-A	4	Pawl
21	335-8	1	Hex Nut No. 8-32	90	50-33-A	4	Spacial Washer
22	515-8-8	1	Round Head Screw No. 8-32 x 1/2	91	55-114-D	2	Bearing Housing
23	53-165-A	1	Cup Spring Washer	92	58-141-A	1	Bearing
24	55-132-A	1	Throttle Spacer	93	60-17-A	1	"V" Pulley (Jack Shaft)
25	30-82-054	1	Wire	94	57-159-B	1	Jack Shaft
26	20-78-6	1	Cable	95	57-154-A	1	Front Tie Rod
27	54-209-A	1	Hook	96	MS# 18-RC	2	Pinion Gear R.H.
28	49-295-A-6	1	Elastic Cord 26" Long	97	367-816	2	Hex Jam Nut 1/2-20 NF
29	55-105-C	1	Canvas Wind Apron	98	57-162-A	2	Special Washer
30	59-09-B	1	Top Basket Rod	99	57-23-C	2	Tire 78-134-C
31	54-162-A	1	Spiral Cable Clip	100	57-192-C	2	Wheel
32	55-142-C	1	Upper Handle	101	57-155-A	2	Axle
33	53-49-B	2	Handle Lower	102	57-162-A	2	Special Washer
34	53-43-B	2	Handle Support Spring	103	560-C-516-10	5	Sq. Hd. Set Screws 3/8-18 x 3/8
35	53-05-C	2	Adjusting Plate	104	57-133-LE	1	Side Plate L.H.
36	515-416-16	4	Round Head Screw 1/4-20 x 1	105	564-C-516-12	1	Allen Head Set Screw 3/8-18 x 3/8
37	53-38-D	1	Canvas Basket	106	47-229-A	1	Cable Clip
38	53-45-B	1	Bottom Basket Rod	107	49-296-A	1	Allen Wrench
39	53-28-A	1	Adjusting Bolt	108	325-1016	2	Hex Nut 3/8-18 NF
40	53-18-A	2	Spacer Nut	109	53-176-D	2	Reel Guard
41	57-136-A	2	Stop Bracket	110	57-160-B	1	Reel Shaft
42	53-08-A	1	Spacer Adjusting Tube	111	57-187-B	1	Brush Strip Assembly (Set of 2) BK-9
43	351-516-40	1	Wing Nut (3/8-18 x 2 1/4)	112	49-17-A	4	Brush Brackets (Set of 2)
44	57-173-A	1	Briggs & Stratton Engine 6.1	113	515-416-28	4	Round Head Screw 1/4-20 x 1 1/4
45	60-16-A	1	"V" Pulley (Engine)	114	57-134-RE	1	Side Plate R.H.
46	48-277-A	1	Key 3/8 x 3/8 x 1	115	58-10-C	1	Hood Extension Assembly
47	564-C-516-6	3	Allen Head Set Screw 3/8-18 x 3/8	116			
48	65-416-32	1	Hex Head Bolt 1/4-20 x 2	117	59-15-D	1	Hood
49	945-416	7	Plain Washer 1/4	118	65-416-12	4	Hex Head Bolts 1/4-20 x 3/8
50	57-150-D	1	Bolt Guard	119	58-18-A	4	Rubber Roller
51	59-14-A	2	Bolt Guard Spacer	120	45-71-A	2	Bushing
52	47-287-A	2	"V" Belt	121	515-416-44	2	Round Head Screw 1/4-20 x 2 3/4
53	53-39-C	1	Aux. Basket Support	122	47-218-B	2	Caster Fork
54	65-516-20	5	Hex Head Bolt 3/8-18 x 1 1/4	123	47-215-A	2	Cone
55	57-135-B	1	Lever	124	45-22-A	2	Bearing and Retainer
56	564-C-416-6	1	Allen Hd. Set Screw 1/4-20 x 3/8	125	47-214-A	2	Bearing Race
57	280-9	2	Woodruff Key No. 9	126	47-216-A	2	Retainer Swivel
58	65-416-20	1	Hex Head Bolt 1/4-20 x 1 1/4	127	65-416-40	2	Hex Head Bolt 1/4-20 x 2 1/2
59	57-130-C	1	Bearing Bracket	128	526-516-20	2	Truss Head Screw 3/8-18 x 1 1/4
60	515-416-6	3	Round Head Screw 1/4-20 x 3/8	129	53-44-B	4	Handle Clamp
61	55-118-A	4	Bearing	130	945-716	6	Washer
62	57-156-B	1	Spring	131	49-426-A	1	1/2 Hex Allen Wrench
63	56-53-A	1	Collar				
64	560-C-516-8	1	Square Hd. Set Screw 3/8-18 x 1/2				
65	57-170-B	1	Cam Shaft				
66	57-179-A	1	Roll Pin				
67	57-152-A	1	Cam				
68	55-161-A	2	Special Washer				
69	57-97-A	1	Roll Pin				

WIND APRON

57-189-C	1	Wind Apron Complete
55-105-C	1	Canvas
54-209-A	1	Hook
49-295-A-4	1	Elastic Cord

HOMEMASTER POWER LAWN SWEEPER	SIZE 28"	PRODUCTION YEAR 1963	MODEL No. HM-5728-B
--	---------------------	---------------------------------	--------------------------------

PARTS LIST

Ref. No.	Part No.	Qty. Per Unit	Description	Ref. No.	Part No.	Qty. Per Unit	Description
1	*65-516-12	4	Bolt — Hex Head $\frac{5}{16}$ - 18 x $\frac{3}{4}$	67	57-152-A	1	Cam
2	*945-516	13	SAE Flat Washer $\frac{5}{16}$	68	55-161-A	2	Washer — Special
3	54-227-A	2	Spacer	69	57-97-A	1	Roll Pin
4	*936-516	19	Lock Washer — Internal Tooth $\frac{5}{16}$	70	58-147-A	1	Bearing
5	*65-516-16	5	Bolt — Hex Head $\frac{5}{16}$ - 18 x 1	71	57-158-A	1	Spacer
6	55-209-A	2	Spacer	72	*70-516-20	2	Bolt — Carriage $\frac{5}{16}$ - 18 x 1 $\frac{1}{4}$
7	57-182-A	1	Bracket — Clutch Bar	73	57-138-E	1	Bracket — Engine Mounting
8	*515-416-20	18	Screw — Round Head $\frac{1}{4}$ - 20 x 1 $\frac{1}{4}$	74	53-139-A	2	"U" Bolt
9	*335-516	21	Nut — Hex $\frac{5}{16}$ - 18	75	57-151-C	1	Bracket — Clutch
10	*936-416	31	Lock Washer — Internal Tooth $\frac{1}{4}$	76	57-184-A	1	Spring
11	*335-416	38	Nut — Hex $\frac{1}{4}$ - 20	77	57-137-C	1	Plate — Engine Mounting
12	57-168-B	1	Clutch Rod	78	*65-516-24	4	Bolt — Hex Head $\frac{5}{16}$ - 18 x 1 $\frac{1}{2}$
13	57-149-C	1	Clutch Bar Sub-Assembly	79	57-153-B	1	Rod — Top Tie
14	*340-516	2	Nut — Hex Jam $\frac{5}{16}$ - 18	80	53-65-A	1	Roll Pin <i>R/W 71-06-A</i>
15	57-147-B	1	Bracket — Throttle Assembly	81	57-157-A	1	Pivot Pin
16	*515-416-8	1	Screw — Round Head $\frac{1}{4}$ - 20 x $\frac{1}{4}$	82	*380-332-16	1	Cotter Pin $\frac{3}{32}$ x 1
17	57-183-A	1	Clamp	83	57-19-B	1	Spacer — Tubular
18	55-156-A	4	Washer — Special	84	53-178-B	1	Tube — Adjusting
19	57-144-B	1	Handle — Throttle Assembly	85	*505-416-8	8	Screw — Flat Head $\frac{5}{16}$ - 18 x $\frac{1}{2}$
20	55-130-A	1	Ball Knob	86	56-94-B	4	Cover — Pinion <i>R/W 80-01-B</i>
21	*935-8	1	Nut — Hex No. 8-32	87	946-1016-16	4	Washer — Fiber
22	*515-8-8	1	Screw — Round Head No. 8-32 x $\frac{1}{2}$	88	63-194-C	2	Pinion Gear L.H. <i>R/W 45-19 R.A.</i>
23	53-165-A	1	Washer — Cup Spring	89	45-25-A	4	Pawl
24	55-132-A	1	Spacer — Throttle	90	50-33-A	4	Washer — Special
25	30-82-054	1	Wire	91	55-114-D	2	Housing — Bearing
26	20-78-6	1	Cable	92	58-141-A	1	Bearing
27	54-209-A	1	Hook	93	60-17-A	1	"V" Pulley (Jack Shaft)
28	49-295-A-6	1	Elastic Cord 26" Long	94	57-159-B	1	Jack Shaft
29	55-105-C	1	Canvas — Wind Apron	95	57-154-A	1	Rod — Front Tie
30	53-09-B	1	Rod — Top Basket	96	63-18-RC	2	Pinion Gear R.H. <i>R/W 45-18-R.A.</i>
31	54-162-A	1	Spiral Cable Clip	97	387-816	2	Nut — Hex Jam $\frac{1}{2}$ - 20-N.F.
32	55-162-C	1	Handle — Upper	98	67-163-A	2	Washer — Special
33	53-49-B	2	Handle — Lower	99	57-236	2	Tire 78-124-C
34	53-49-B	2	Spring — Handle Support	100	57-132-C	2	Wheel
35	53-05-C	2	Plate — Adjusting	101	57-155-A	2	Axle
36	*515-416-16	4	Screw — Round Head $\frac{1}{4}$ - 20 x 1	102	57-162-A	2	Washer — Special
37	53-38-D	1	Basket	103	560-C-516-10	5	Set Screw — Square Head $\frac{5}{16}$ - 18 x $\frac{3}{4}$
38	53-45-B	1	Rod — Bottom Basket	104	57-133-LE	1	Side Plate L.H.
39	53-28-A	1	Bolt — Adjusting	105	564-C-516-12	1	Set Screw — Allen Head $\frac{5}{16}$ - 18 x $\frac{3}{4}$
40	53-18-A	2	Spacer Nut	106	47-229-A	1	Cable Clip
41	57-136-A	2	Bracket — Stop	107	49-296-A	1	$\frac{3}{32}$ Hex Allen Wrench
42	564-C-516-4	1	Set Screw — Allen Head $\frac{5}{16}$ - 18 x $\frac{1}{4}$	108	*325-1016	2	Nut — Hex $\frac{3}{8}$ - 18-N.F.
43	351-516-40	1	Wing Nut $\frac{3}{16}$ - 1.8 x 2 $\frac{1}{2}$ Wing Span	109	53-176-D	2	Guard — Reel
44	57-173-A	1	Engine — Briggs & Stratton 6.1	110	57-160-B	1	Reel Shaft
45	60-16-A	1	"V" Pulley (Engine)	111	57-187-B	1	Brush Strip Assembly (Set of 2) <i>R/W BK-9</i>
46	48-277-A	1	Key $\frac{3}{16}$ x $\frac{3}{16}$ x 1"	112	49-17-A	4	Bracket — Brush
47	564-C-516-6	3	Set Screw — Allen Head $\frac{5}{16}$ - 18 x $\frac{3}{4}$	113	*515-416-28	4	Screw — Round Head $\frac{1}{4}$ - 20 x 1 $\frac{1}{4}$
48	*65-416-32	1	Bolt — Hex Head $\frac{1}{4}$ - 20 x 2	114	57-134-RE	1	Side Plate R.H.
49	*945-416	7	SAE Flat Washer $\frac{1}{4}$	115	58-10-C	1	Head Extension Assembly
50	57-150-D	1	Guard — Belt	116	563-C-1032-3	2	Set Screw — Allen Hd. No. 10-32 x $\frac{3}{4}$
51	59-14-A	3	Spacer	117	59-15-D	1	Head
52	47-287-A	2	"V" Bolt (Matched Sets)	118	*65-416-12	4	Bolt — Hex Head $\frac{1}{4}$ - 20 x $\frac{3}{4}$
53	63-50-D	1	Support — Aux. Basket	119	63-52-B	2	Roller — Rubber
54	*65-516-20	5	Bolt — Hex Head $\frac{5}{16}$ - 18 x 1 $\frac{1}{4}$	120	45-71-A	2	Bushing
55	57-135-B	1	Lever	121	*515-416-44	2	Screw — Round Head $\frac{1}{4}$ - 20 x 2 $\frac{3}{4}$
56	564-C-416-6	1	Set Screw — Allen Head $\frac{1}{4}$ - 20 x $\frac{3}{8}$	122	47-218-B	2	Fork — Caster
57	280-9	2	Woodruff Key No. 9	123	63-48-A	2	Spacer
58	*65-416-20	1	Bolt — Hex Head $\frac{1}{4}$ - 20 x 1 $\frac{1}{4}$	124	53-02-B	2	Plate — Caster Mounting
59	57-130-C	1	Bracket — Bearing	125	53-37-C	1	Frame — Basket Bottom
60	*515-416-6	3	Screw — Round Head $\frac{1}{4}$ - 20 x $\frac{3}{8}$	126	57-189-C	1	Wind Apron Complete
61	55-110-A	4	Bearing	127	*65-416-40	2	Bolt — Hex Head $\frac{1}{4}$ - 20 x 2 $\frac{1}{2}$
62	57-156-B	1	Spring	128	63-51-B	2	Cross Tube
63	56-53-A	2	Collar	129	53-44-B	4	Clamp — Handle
64	560-C-516-8	1	Set Screw — Square Head $\frac{5}{16}$ - 18 x $\frac{1}{2}$	130	49-426-A	1	$\frac{1}{8}$ Hex Allen Wrench
65	57-170-B	1	Cam Shaft	131	63-29-A	4	Washer — Special
66	57-179-A	1	Roll Pin	132	63-53-B	2	Caster Assembly

HM-5728-B



MODEL
HM-5728-B

LAWN SWEEPER

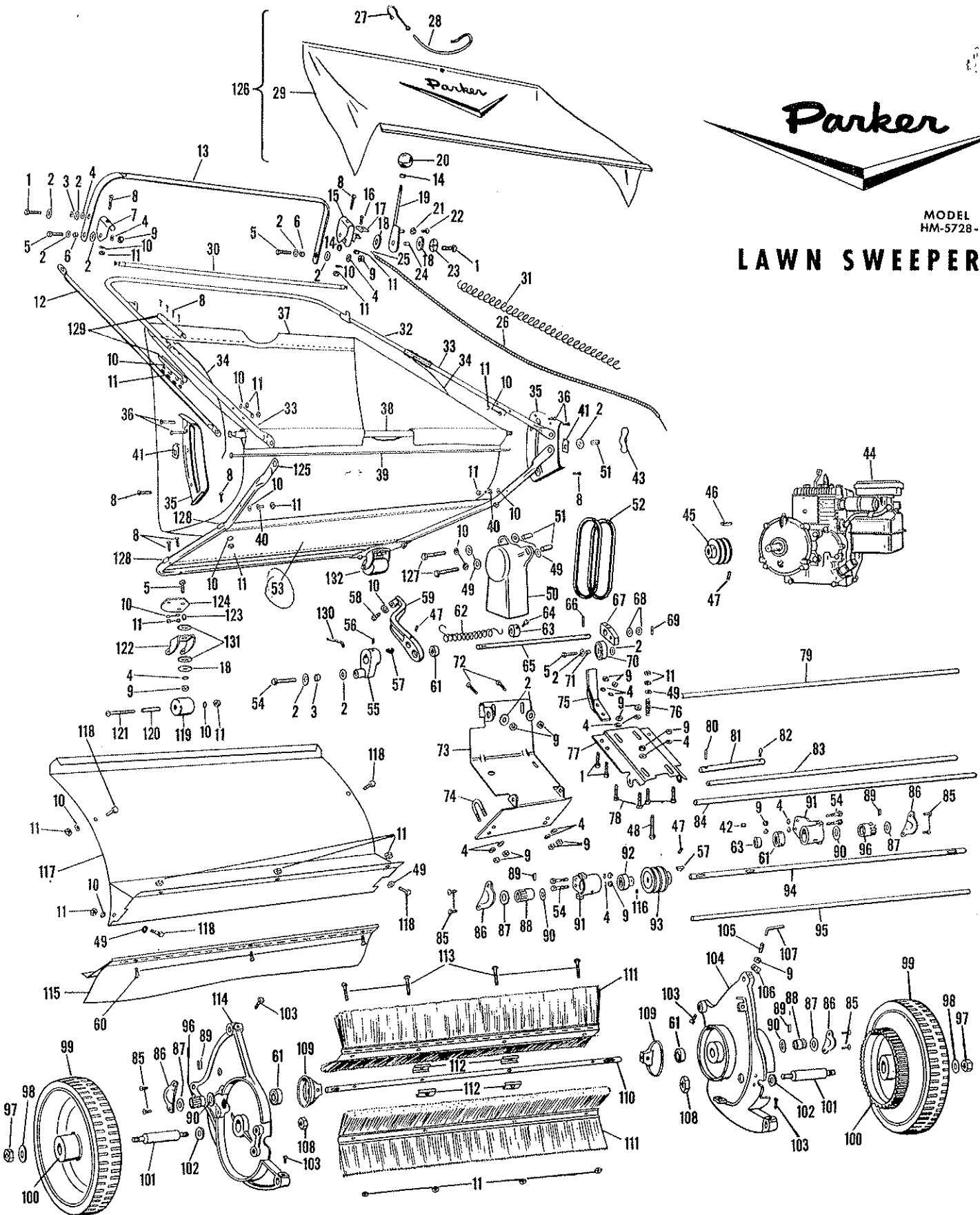

When ordering specify sweeper model number (found on side plate or hood) and length of brushes.
The words "right" and "left" refer to the sides of the sweeper when facing in the direction machine travels in use.

PARKER SWEEPER COMPANY

BOX 720

SPRINGFIELD, OHIO 45501

PARKER TINE-A-MATIC POWER RAKE ATTACHMENT	MODELS USED WITH HM-5728 & HM-5728A	1961
--	--	-------------

REF. NO.	PART NO.	DESCRIPTION	NO. REQ.	REF. NO.	PART NO.	DESCRIPTION	NO. REQ.
1	65-416-28	HEX. HD. BOLT 1/4 x 3/4	2	8	60-91RB	END HANGER R.H.	2
2	60-90LB	END HANGER L.H.	2	9	46-81A	SPECIAL WASHER	164
3	60-92B	SPRING TINE	136	10	335-416	HEX NUT 1/4-20	4
4	60-86B	CENTER HANGER	4	11	935-416	LOCK WASHER 1/4	4
5	65-416-24	HEX. HD. BOLT 1/4 x 1/2	2	12	945-516	PLAIN WASHER 5/16 SAE	16
6	60-93A	SPRING ROD RETAINER	4	13	53-65A	ROLL PIN	16
7	60-94A	SPRING ROD	4				

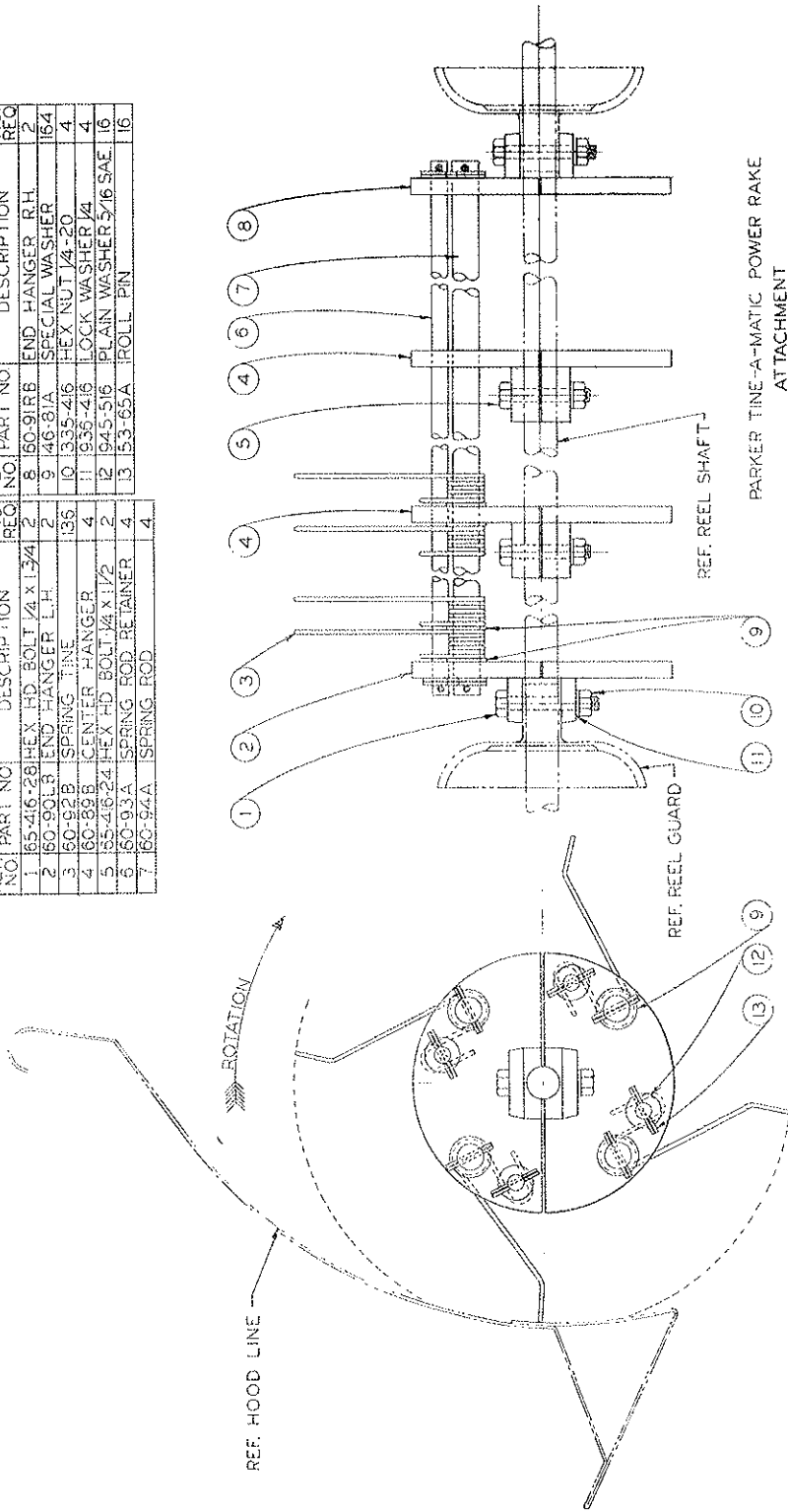

FOR HOMEMASTER MODELS HM5728 & 5728-A

ASSEMBLY INSTRUCTIONS

1. REMOVE FIBER BRUSHES FROM REEL SHAFT.
 2. ASSEMBLE IN THEIR PLACE THE SPRING TINE ASSEMBLY, MAKE SURE THAT THE SPRING TINES ARE LAYING AS SHOWN IN RELATION TO THE ROTATION AND SWEEPER HOOD.
- IT IS IMPORTANT THAT THIS ASSEMBLY IS NOT REVERSED OR SEVERE DAMAGE TO THE SPRING TINES WILL RESULT.

PARKER SWEEPER COMPANY

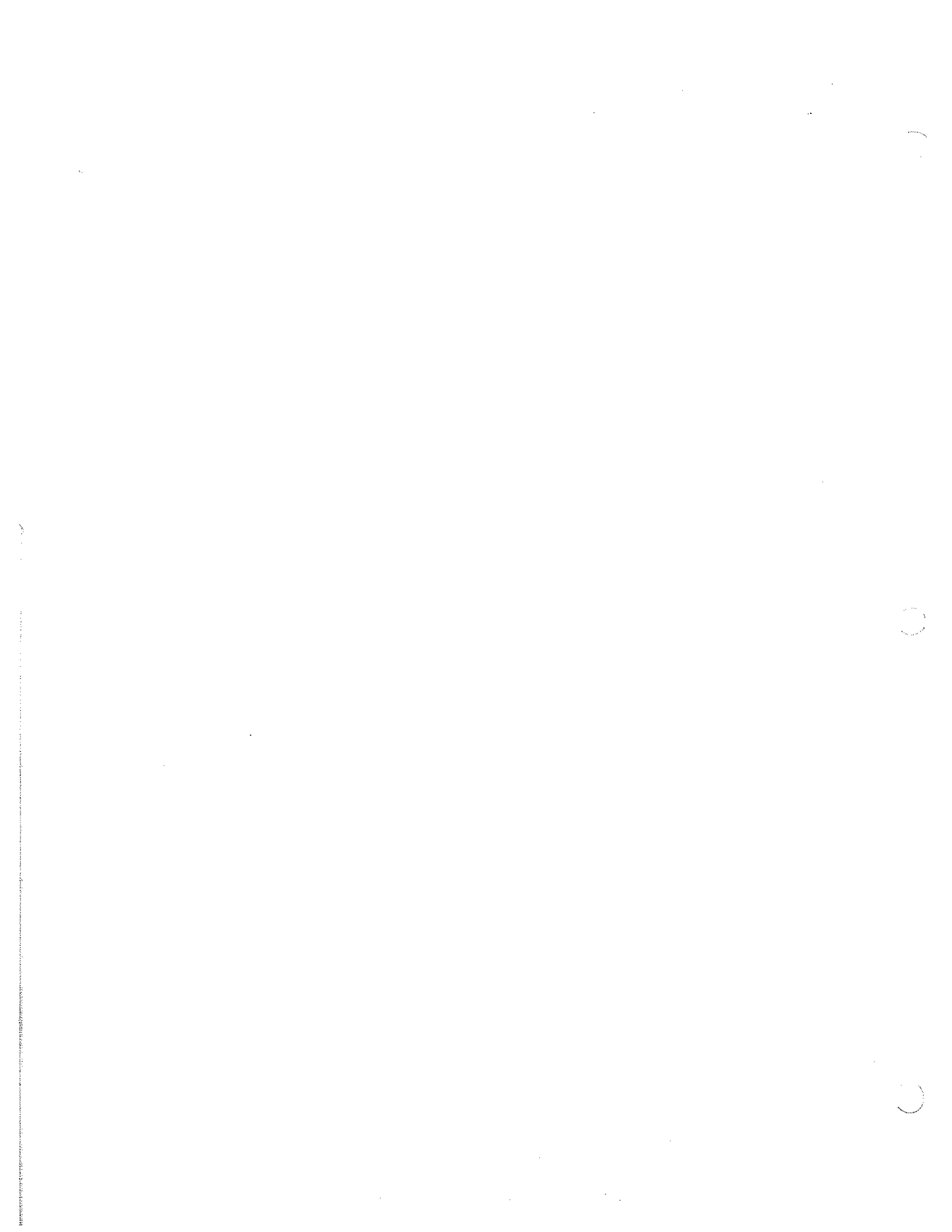

PARKER TINE-A-MATIC POWER RAKE ATTACHMENT	MODELS USED WITH HM-5728, HM-5728-A & HM-5728-B	PRODUCTION YEAR 1963

REF. NO.	PART NO.	DESCRIPTION	NO. REQ.	REF. NO.	PART NO.	DESCRIPTION	NO. REQ.
1	65-416-28	HEX HD. BOLT 1/4 X 1 3/4	2	8	160-91RB	END HANGER RH.	2
2	60-90LB	END HANGER L.H.	2	9	146-81A	SPECIAL WASHER	16
3	60-92B	SPRING TINE	136	10	1335-416	HEX NUT 1/4-20	4
4	60-89B	CENTER HANGER	4	11	1936-416	LOCK WASHER 1/4	4
5	65-416-24	HEX HD BOLT 1/4 X 1/2	2	12	1945-516	PLAIN WASHER 5/16 SAE	16
6	60-93A	SPRING ROD RETAINER	4	13	153-65A	ROLL PIN	16
7	60-94A	SPRING ROD	4	14	1946-816	FIBER WASHER	206
				15	162-236A	STRIKE PLATE	1

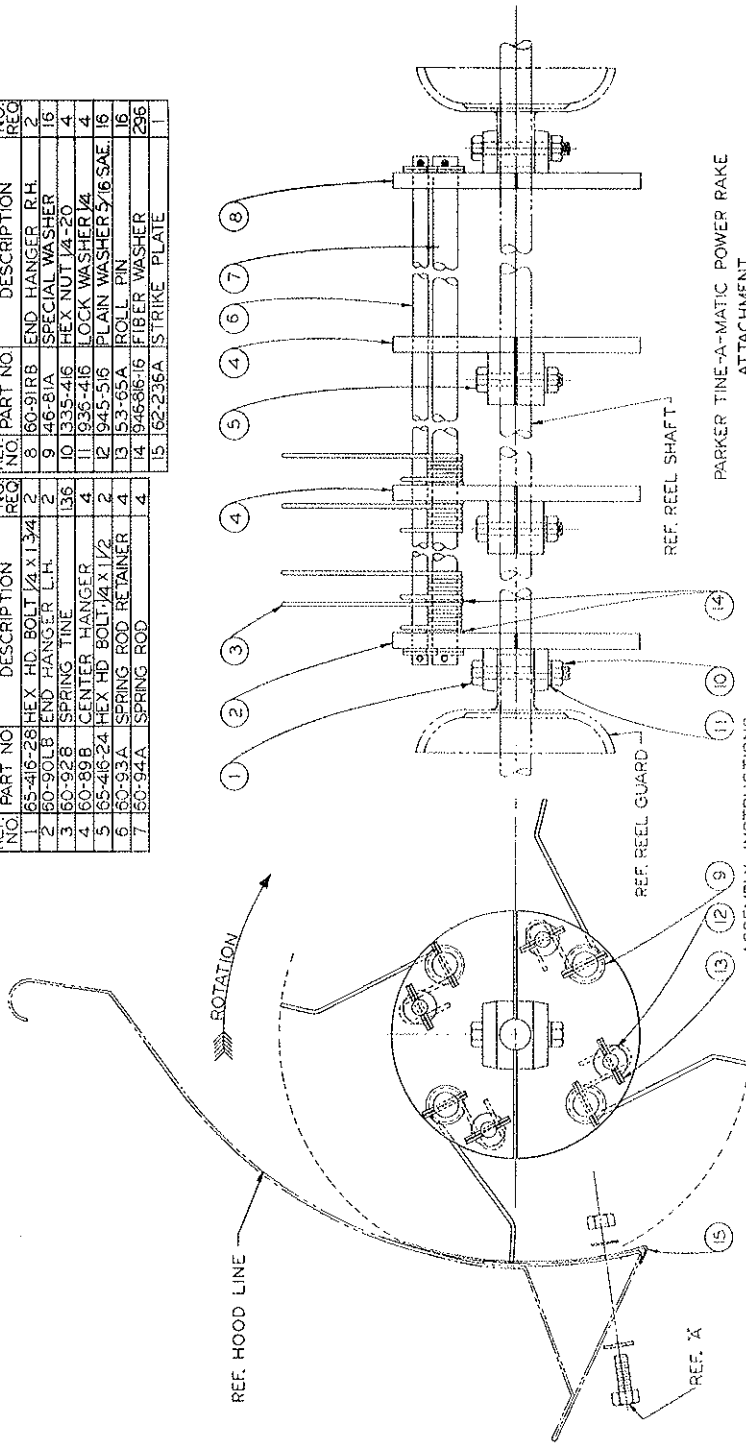

PARKER TINE-A-MATIC POWER RAKE
ATTACHMENT
FOR HOMEMASTER MODELS HM5728, 5728A, & 5728B

- ASSEMBLY INSTRUCTIONS
1. REMOVE FIBER BRUSHES FROM REEL SHAFT.
 2. ASSEMBLE IN THEIR PLACE THE SPRING TINE ASSEMBLY. MAKE SURE THAT THE SPRING TINES ARE LAYING AS SHOWN IN RELATION TO THE ROTATION AND SWEEPER HOOD.
 3. REMOVE HARDWARE AT REF 'A' AT LOWER CORNER OF HOOD AND PLACE STRIKE PLATE IN POSITION AS SHOWN. REPLACE HARDWARE IN SAME ORDER IT WAS REMOVED.

IT IS IMPORTANT THAT THIS ASSEMBLY IS NOT REVERSED OR SEVERE DAMAGE TO THE SPRING TINES WILL RESULT.

THE UNIVERSITY OF CHICAGO
LIBRARY

1

2

3

UNIVERSITY OF CHICAGO
LIBRARY