



Electronic Service Manuals

This electronic document is provided as a service to our customers. We do not create the contents of the information contained in this document. Should you have detailed questions pertaining to the information contained in this document, you may contact Michco, or the manufacturer which provided the original information in this electronic deliverable. Michco's only part in this electronic deliverable was the electronic assembly process. By providing this manual on line we are not guaranteeing parts availability.

You may contact Michco through the following methods:

Phone (517) 484-9312 or (800) 331-3339

2011 N. High St. -- Lansing, Michigan -- 48906

Fax: (517) 484-9836

Email: CustServe@Michco.com

Web site: www.Michco.Com

Parts Web site: www.FloorMachineParts.Com

Order Parts on Line at:

www.FloorMachineParts.Com

Directly to Parts & Service:

By Email: **Shop@Michco.com**

By Fax: (517) 702-2041

By Voice: Use numbers above.

Serving the Cleaning Industry Since 1922

Notice: All copyrighted material remains property of original owners, all trademarks are property of respective owners. Manuals are subject to Manufacturer's reproduction limitations. Originals or reproductions were provided by manufacturers through a request. We make no warranty as to the correctness of information provided in this document and you assume all risk. By placing these manuals on line we are not declaring our corporation to be an manufacturer authorized dealer or provider, please check our web site for authorized manufacturers we represent.

PARTS LIST
CHARGER 2717 AB

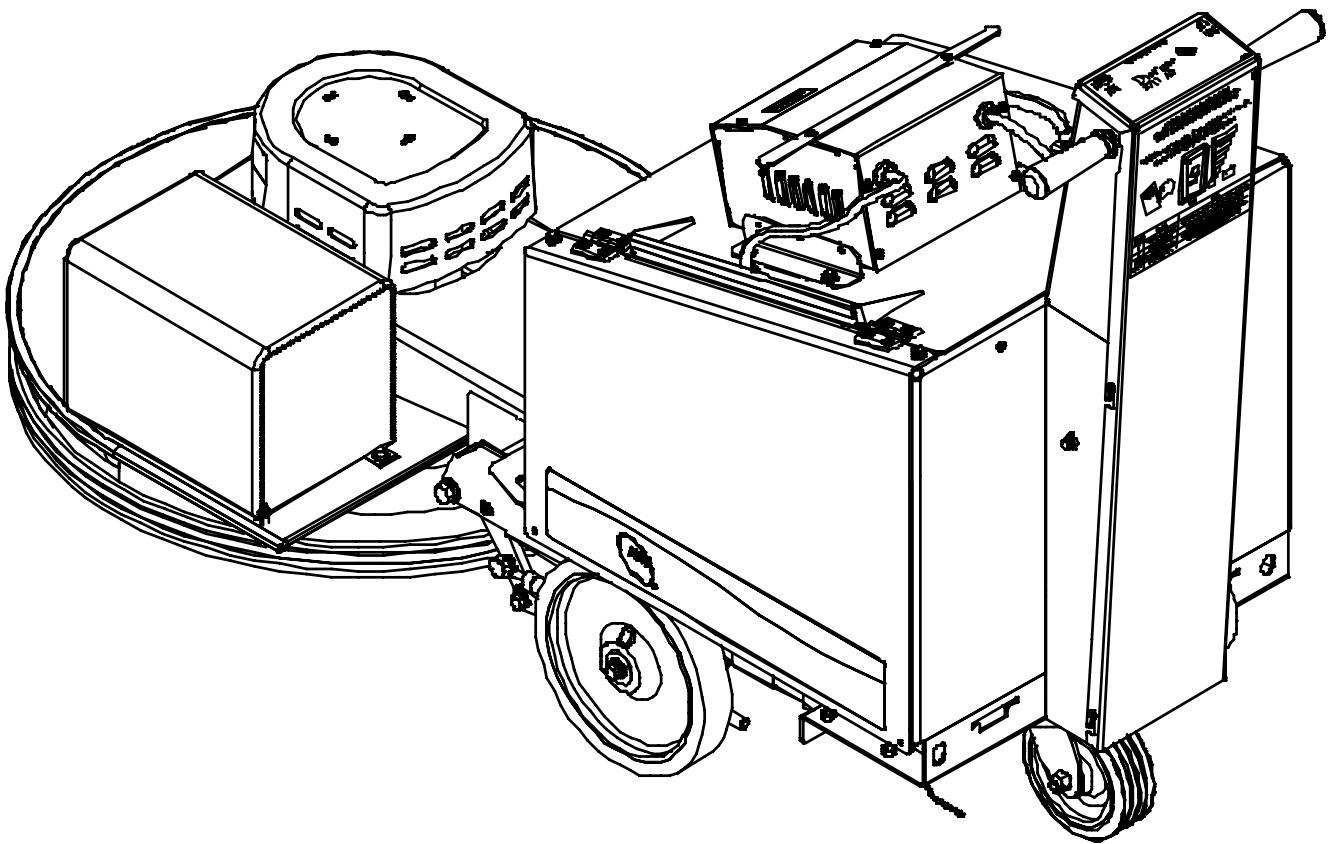

<u>ITEM</u>	<u>PART NO.</u>	<u>PART DESCRIPTION</u>	<u>QTY.</u>
101	6497261	AXLE / PIVOT MOUNT	2
102	6495891	PIVOT	2
103	2691181	PIVOT SPACER, STABILIZER BAR	4
104	9122180	13/32 X 13/16 X .051 THICK WASHER - PACK OF 10	4
105	9122100	3/8 SPLIT LOCK WASHER - PACK OF 10	4
106	9122260	3/8-16 X 1 HEX BOLT - PACK OF 5	4
107	9122260	3/8-16 X 1 HEX BOLT - PACK OF 2	2
108	9122100	3/8 SPLIT LOCK WASHER - PACK OF 10	2
109	9122180	13/32 X 13/16 X .051 THICK WASHER - PACK OF 10	2
110	6497211	CHASSIS / BODY	1
111	3394571	6" X 2" MAROON CASTER ASSEMBLY	1
112	9122180	13/32 X 13/16 X .051 THICK WASHER - PACK OF 10	4
113	9122100	3/8 SPLIT LOCK WASHER - PACK OF 10	4
114	9122260	3/8-16 X 1 HEX BOLT - PACK OF 5	4
115	9120380	10-24 X 3/8 ROUND HEAD PHILLIPS MACHINE SCREW - PACK OF 10	1
116	9120330	#10 EXTERNAL STAR LOCK WASHER - PACK OF 10	1
117	6491871	END COUPLING ROUND BEAD CHAIN	1
118	6491860	ROUND BEAD CHAIN - CUT TO 8"	.7
119	9121420	5/16-18 HEX NUT - PACK OF 10	1
120	6497201	GAS SPRING MOUNT	2
121	9121410	5/16 EXTERNAL STAR LOCK WASHER - PACK OF 10	1
122	6496541	BALL STUD - GAS SPRING MOUNT	1
123	6497371	10" WHEEL	2
124	6497301	AXLE	1
125	9122260	3/8-16 X 1 HEX BOLT - PACK OF 2	2
126	9122100	3/8 SPLIT LOCK WASHER - PACK OF 10	2
127	9122180	13/32 X 13/16 X .051 THICK WASHER - PACK OF 10	2
128	9122260	3/8-16 X 1 HEX BOLT - PACK OF 2	2
129	9122100	3/8 SPLIT LOCK WASHER - PACK OF 10	2
130	9122180	13/32 X 13/16 X .051 THICK WASHER - PACK OF 10	2

CHASSIS ASSEMBLY

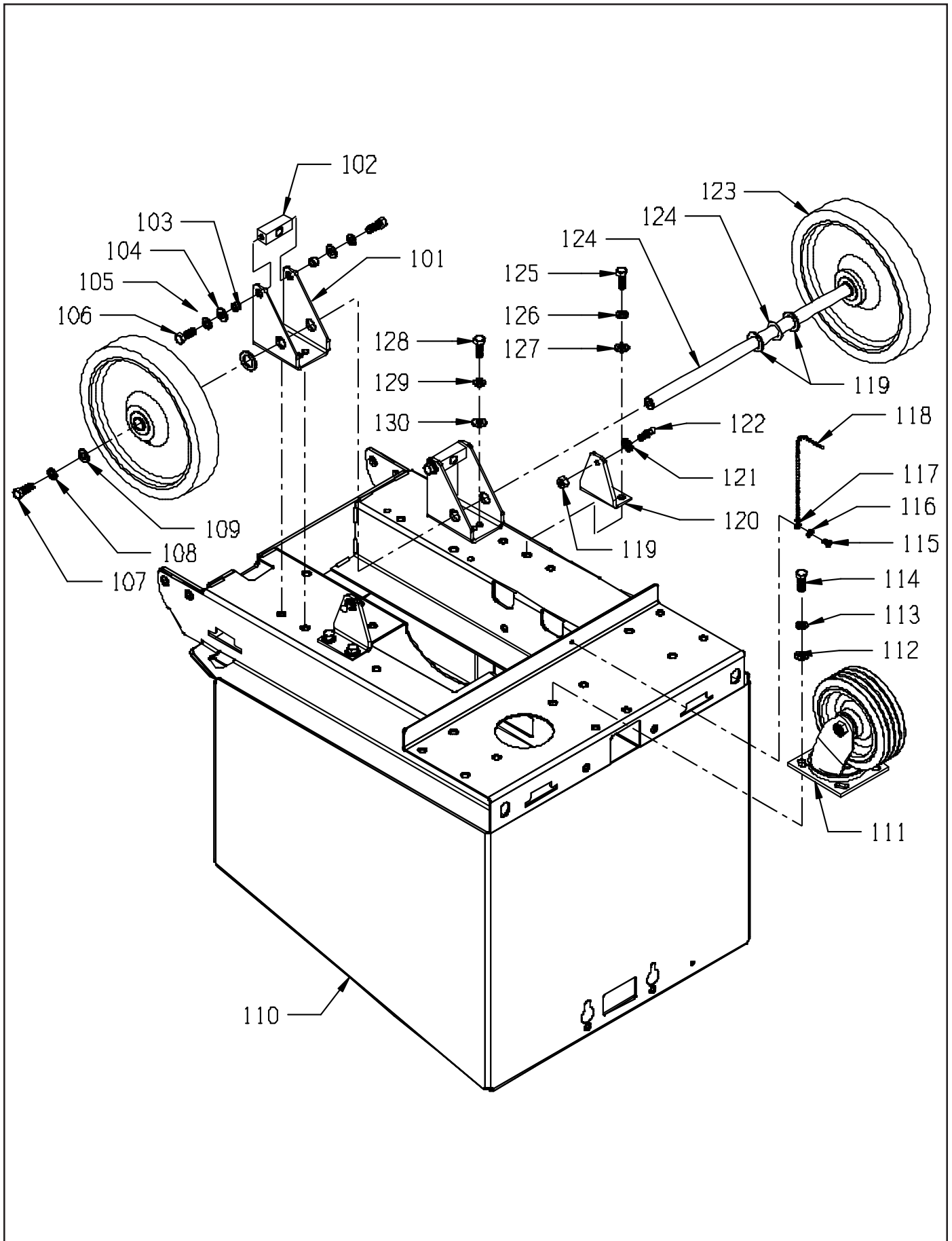

ITEM	PART NO.	PART DESCRIPTION	QTY.
201	5990731	SPRING CLIP PAD HOLDER SET - INCLUDES:	1
201A	9120205	8 X 1/2 PAN HEAD PHILLIPS SHEET METAL SCREW - PACK OF 3	3
202	9121490	5/16-24 X 7/8 HEX BOLT - PACK OF 2	1
203	9121520	5/16 SPLIT LOCK WASHER - PACK OF 10	1
204	9121985	13/32 I.D. X 1 O.D. X .12 THICK FLAT WASHER 11 GAGE - PACK OF 1	1
205	9120827	3/16 SQUARE X 1" LONG KEY - STEEL - PACK OF 2	1
206	6492571	DRIVER, PAD - 27"	1
207	9120980	1/4-20 X 1 SOCKET HEAD CAP SCREW - PACK OF 5	3
208	9120880	1/4 SPLIT LOCK WASHER - PACK OF 10	3
209	9120950	1/4 X 1 1/4 FENDER WASHER - PACK OF 10	3
210	6496519	FLEXIWALL SHIELD 27 ASSEMBLY - INCLUDES:	1
210A	6592531	BUMPER / BRUSH 27"	1
210B	6592552	BUMPER STRAP 27	1
210C	9120350	10-24 HEX NUT WITH NY-LOCK INSERT - PACK OF 10	1
210D	9120450	10-24 X 1 ROUND HEAD PHILLIPS MACHINE SCREW - PACK OF 10	1
211	9997590	METAL CORE QUICKEDGE TRIM - CUT TO 67"	5.6
212	6496721	MOTOR - 36 VOLT, 2100 RPM, 3.6HP	1
213	7692421	TERMINAL BOOT (RED)	1
214	9121410	5/16 EXTERNAL STAR LOCK WASHER - PACK OF 10	2
215	6496621	STEEL SKIRT - 27"	1
216	6496881	STUD WITH #10-32 X 3/8, FILTER BAG	1
217	9120660	10-32 X HEX NUT WITH NY-LOCK INSERT - PACK OF 10	1

HEAD ASSEMBLY

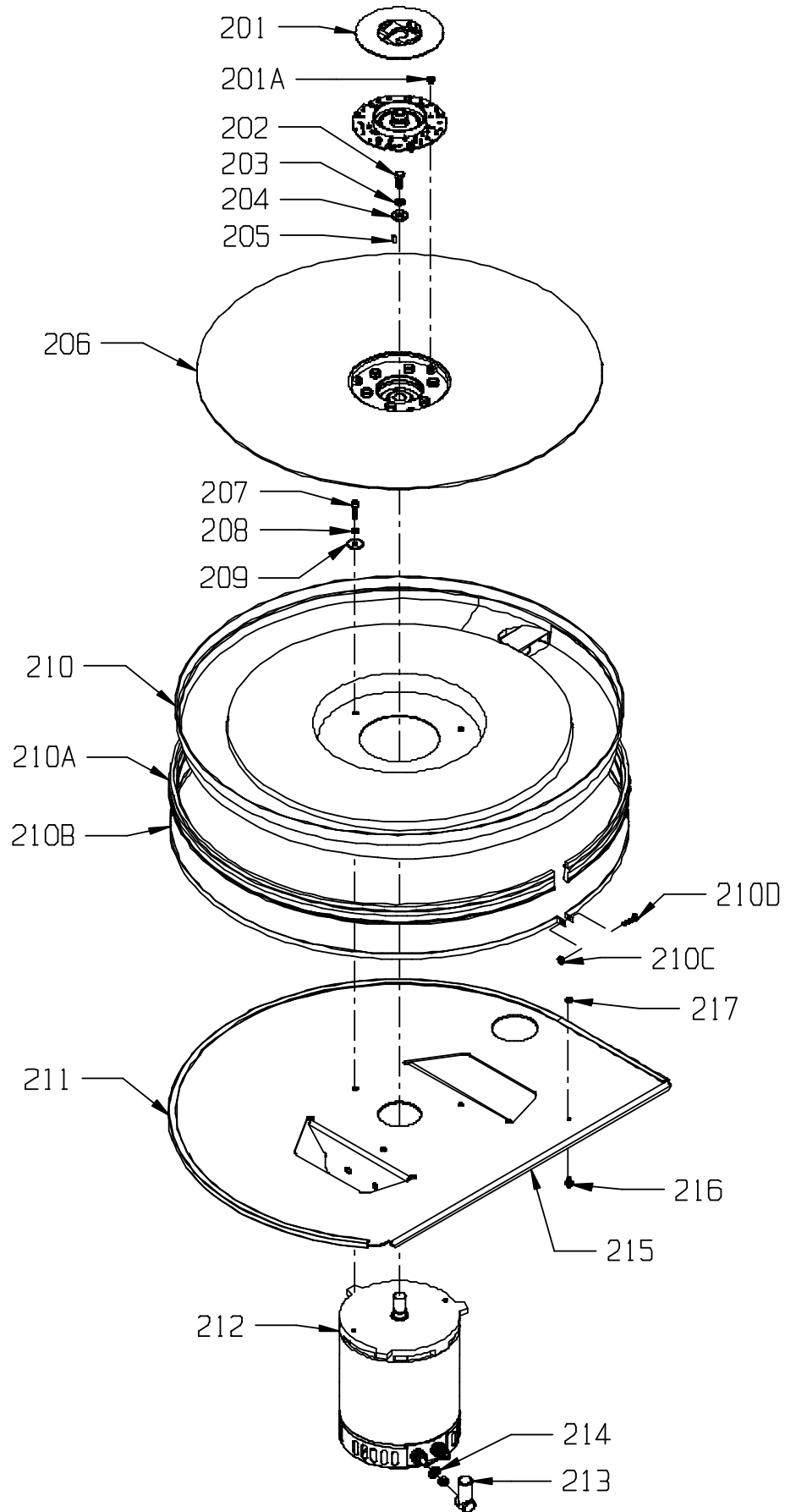

<u>ITEM</u>	<u>PART NO.</u>	<u>PART DESCRIPTION</u>	<u>QTY.</u>
301	9120600	10-24 X 1/2 PAN HEAD PHILLIPS THREAD CUTTING SCREW - PACK OF 10	4
302	9120370	7/32 I.D. X 1/2 O.D. X .032/.065 THICK FLAT WASHER (#10) - PACK OF 10	4
303	9120205	8 X 1/2 PAN HEAD PHILLIPS SHEET METAL SCREW - PACK OF 3	2
304	6793371	RUBBER FOOT	2
305	0393531	NSS LOGO DECAL - 3.5 X 4.0	1
306	6496641	MOTOR COVER	1
307	9122260	3/8-16 X 1 HEX BOLT - PACK OF 2	1
308	9122100	3/8 SPLIT LOCK WASHER - PACK OF 10	1
309	6497551	ARM 27 AB/DB BRUSH ASSEMBLY	1
310	6496651	GRIP BASE	1
311	3392901	HANDLE GRIP	1
312	9122020	3/8 X 3/8 SOCKET HEAD SHOULDER BOLT - PACK OF 1	4
313	9120530	10-24 X 7/8 TRUSS HEAD PHILLIPS MACHINE SCREW - PACK OF 5	2
314	2790751	BUSHING SPACER	2
315	9122450	17/32 I.D. X 1 1/16 O.D. X .074/.121 THICK FLAT WASHER (1/2) - PACK OF 5	2
316	9122420	1/2 SPLIT LOCK WASHER - PACK OF 5	2
317	9122550	1/2-13 X 1 1/2 HEX BOLT - PACK OF 1	2
318	6496711	BAG, FILTER MEDIA	1
319	9122300	3/8-16 X 1 1/4 HEX BOLT - PACK OF 2	2
320	9122100	3/8 SPLIT LOCK WASHER - PACK OF 10	2
321	9122180	13/32 I.D. X 13/16 O.D. X .051/.080 THICK FLAT WASHER (3/8) - PACK OF 10	2
322	2691181	PIVOT SPACER, STABILIZER BAR	2
323	6496671	COMPRESSION SPRING 1.75 X .935 O.D.	2
324	6496681	GUIDE, SPRING	2
325	3393891	COLLAR, SHAFT 1/2"	2
326	9122140	3/8-16 HEX NUT WITH NY-LOCK INSERT - PACK OF 5	2
327	9121450	5/16-18 HEX NUT WITH NY-LOCK INSERT - PACK OF 5	1
328	2395761	CLAMP, TUBE	1
329	9121410	5/16 EXTERNAL STAR LOCK WASHER - PACK OF 10	2
330	6496541	BALL STUD - GAS SPRING MOUNT	2
331	6496531	GAS SPRING (GGS 23-120 I) - INCLUDES:	2
	6496771	SPRING CLIP	2
332	9120350	10-24 HEX NUT WITH NY-LOCK INSERT - PACK OF 10	2
333	6496781	TILT SWITCH	1
334	4991371	FULLY INSULATED MALE TERMINAL 22-18 GAGE	2
335	9121600	5/16-18 X 5/8 HEX NUT - PACK OF 5	1

HEAD ARM ASSEMBLY

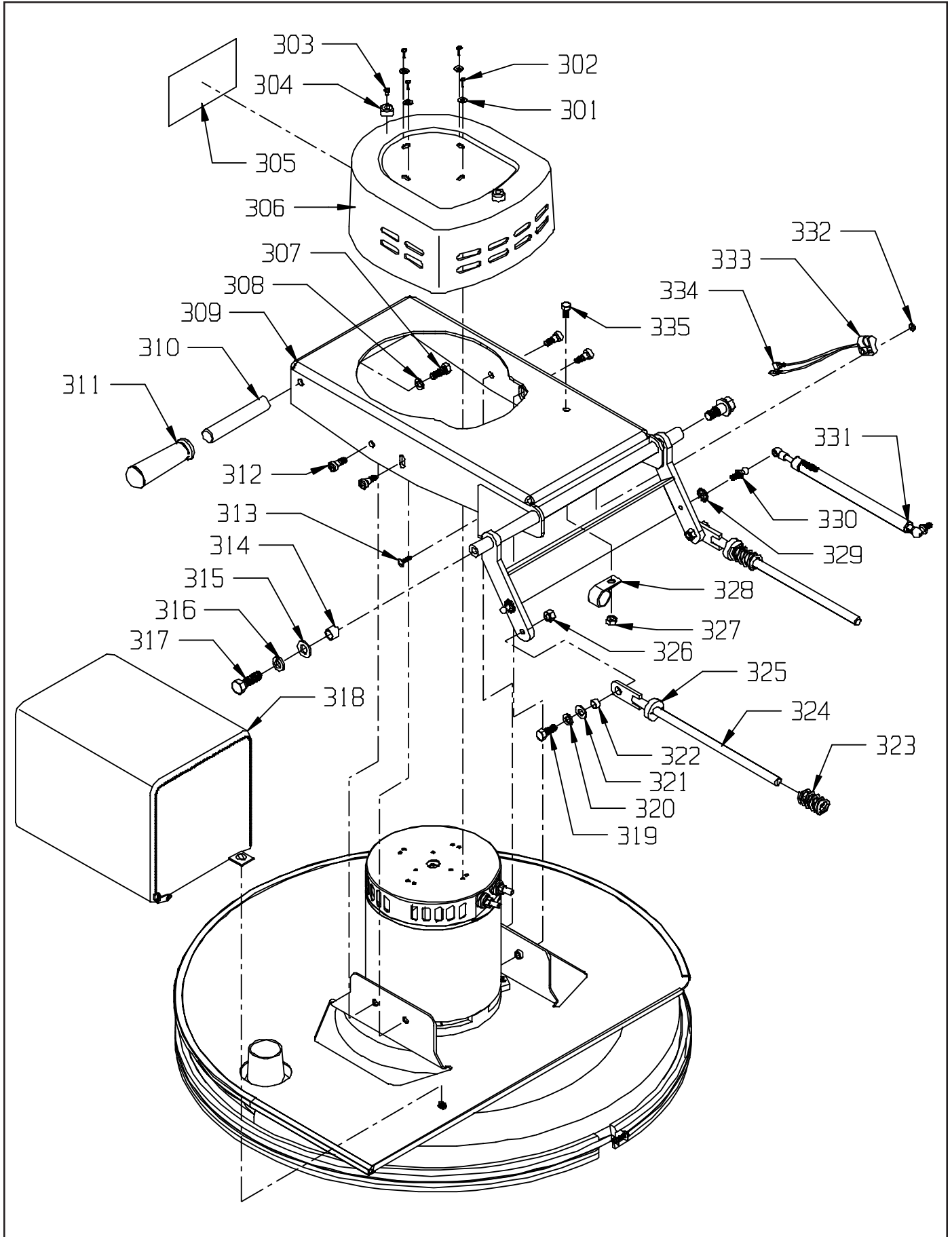

<u>ITEM</u>	<u>PART NO.</u>	<u>PART DESCRIPTION</u>	<u>QTY.</u>
401	3392901	HANDLE GRIP	2
402	2691871	HANDLE GRIP BASE	2
403	2391941	BALL JOINT	2
404	9120990	1/4-20 X 3/8 TRUSS HEAD PHILLIPS MACHINE SCREW - PACK OF 5	1
405	9121050	1/4-20 X 1-1/4 SOCKET HEAD CAP SCREW - PACK OF 5	1
406	9120100	6-32 X 1 ROUND HEAD PHILLIPS MACHINE SCREW - PACK OF 10	2
407	4491071	SNAP SWITCH	1
408	6496991	POTENTIOMETER BRACKET	1
409	9120020	6-32 HEX NUT WITH STAR LOCK WASHER - PACK OF 10	2
411	9122420	1/2 SPLIT LOCK WASHER - PACK OF 5	2
412	9122700	1/2-20 X 1 HEX BOLT - PACK OF 2	2
413	9120510	10-24 X 1/2 TRUSS HEAD PHILLIPS MACHINE SCREW - PACK OF 10	2
414	9120330	10 EXTERNAL STAR LOCK WASHER - PACK OF 10	2
415	9120370	7/32 I.D. X 1/2 O.D. X .032/.065 THICK FLAT WASHER (#10) - PACK OF 10	2
416	9120430	10-24 X 3/4 ROUND HEAD PHILLIPS MACHINE SCREW - PACK OF 10	4
417	9120370	7/32 I.D. X 1/2 O.D. X .032/.065 THICK FLAT WASHER (#10) - PACK OF 10	4
418	6496811	WIRE ASSEMBLY, ANDERSON - MACHINE - INCLUDES:	1
	6491841	175 AMP ANDERSON WITH CONTACTS GRAY 36 VOLT	1
419	9120900	1/4-20 HEX NUT WITH NY-LOCK INSERT - PACK OF 10	2
420	6491261	CIRCUIT BREAKER - 90 AMP	1
421	9120510	10-24 X 1/2 TRUSS HEAD PHILLIPS MACHINE SCREW - PACK OF 10	5
422	6496601	CONTROL FRAME	1
423	6497411	CONTROL FRAME COVER	1
424	6496971	BATTERY METER WITH HARNESS - INCLUDES:	1
	6496981	BATTERY METER DISPLAY	1
	6496961	WIRE HARNESS, BATTERY METER - 10 PIN	1
425	6497361	BATTERY METER/CODES DECAL AB	1
426	6497341	NAMING LABEL, CHARGER 2717 AB	1
427	6497039	KEY SWITCH KIT (OPTIONAL) - INCLUDES:	1
	7692511	KEY SWITCH & KEY	1
	6497021	WIRE ASSEMBLY, KEY SWITCH	1
428	2397361	HOUR METER	1
429	6496451	FAST-ACTING FUSE 2 AMP	1
430	4990321	FUSE HOLDER WITH NUT & WASHER	1
431	6497451	CONTROLLER 2717 AB (0105-0001)	1
	9120970	1/4 EXTERNAL STAR LOCK WASHER - PACK OF 10	5
	9120985	1/4-28 X 3/8 PAN HEAD PHILLIPS MACHINE SCREW	5
432	6497571	DECAL WIRING DIAGRAM CHARGER AB	1
433	9120350	10-24 HEX NUT WITH NY-LOCK INSERT - PACK OF 10	4
434	7692421	TERMINAL BOOT (RED)	1
435	4491011	SOLENOID, 36 VOLT	1
436	9120930	9/32 I.D. X 5/8 O.D. X .051/.080 THICK FLAT WASHER (1/4) - PACK OF 10	2
437	9120900	1/4-20 HEX NUT WITH NY-LOCK INSERT - PACK OF 10	2
438	9121210	1/4-20 X 5/8 HEX BOLT - PACK OF 10	1
439	9120970	1/4 EXTERNAL STAR LOCK WASHER - PACK OF 10	1
440	4490561	INSULATED STANDOFF	1
441	9120880	1/4 SPLIT LOCK WASHER - PACK OF 10	1
442	9121170	1/4-20 X 1/2 HEX BOLT - PACK OF 10	1
443	3394721	FUSE DECAL	1
444	9121060	1/4-20 X 1 1/4 HEX BOLT - PACK OF 5	2
445	9122465	.516 I.D. X .813 O.D. X .027/.030 THICK FLAT WASHER - PACK OF 2	2
446	0691851	1/2 INTERNAL STAR LOCK WASHER	2
447	0798821	5/8" HEX NUT (LARGE NUT)	2
448	4491101	TOGGLE SWITCH, MOTOR	2
449	6496191	HANDLE BAR 2716	1
450	6496081	BEARING PLAIN SLEEVE .5 X .75 X .75 LONG	1
451	6496091	SPRING TORSION .81 I.D. .067 WIRE	1
452	6496171	COLLAR, SHAFT 1/2" SET SCREW	2
453	3393891	COLLAR, SHAFT 1/2"	2
454	9120270	8-32 X 7/8 ROUND HEAD PHILLIPS MACHINE SCREW - PACK OF 10	2
455	9120200	8 SPLIT LOCK WASHER - PACK OF 10	2

CONTROL PANEL ASSEMBLY

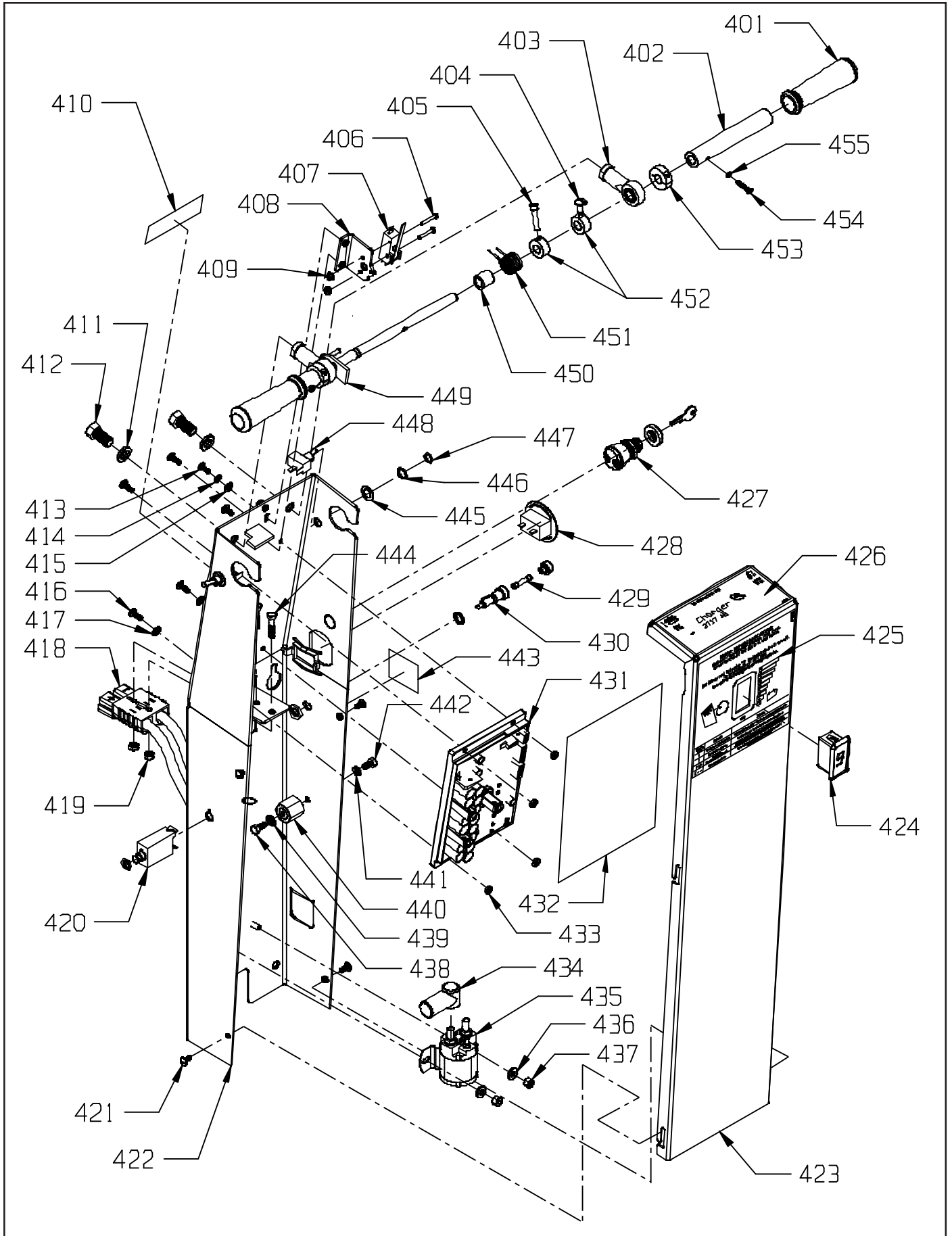

<u>ITEM</u>	<u>PART NO.</u>	<u>PART DESCRIPTION</u>	<u>QTY.</u>
501	9121270	1/4-20 X 1 HEX BOLT - PACK OF 10	1
502	9121210	1/4-20 X 5/8 HEX BOLT - PACK OF 10	3
503	9120880	1/4 SPLIT LOCK WASHER - PACK OF 10	4
504	9120930	9/32 I.D. X 5/8 O.D. X .051/.080 THICK FLAT WASHER (1/4) - PACK OF 10	3
505	6497531	36 VOLT ON-BOARD CHARGER 25A DP - 100/115/230 50/60HZ INPUT	1
505	6495701	120 VOLT ON-BOARD CHARGER CORD	1
505	6495711	240 VOLT ON-BOARD CHARGER CORD	1
505	2695841	BRACKET, MOUNTING CHARGER DP	2
505	2695861	CORD WRAP	1
506	4890451	BUSHING, SNAPIN, #SB87511 HEYCO	1
507	9121037	1/4-20 X 5/8 FLAT HEAD PHILLIPS MACHINE SCREW - PACK OF 10	8
508	6497811	HINGE, LID	2
509	6497221	LID, BODY	1
510	9120900	1/4-20 HEX NUT WITH NY-LOCK INSERT - PACK OF 10	8
511	9997590	METAL CORE QUICKEDGE TRIM - CUT TO 12"	1
512	4890851	CABLE CLAMP, #COV-090 KMC	1
513	9120900	1/4-20 HEX NUT WITH NY-LOCK INSERT - PACK OF 10	4
514	9120900	1/4-20 HEX NUT WITH NY-LOCK INSERT - PACK OF 10	1
515	9120930	9/32 I.D. X 5/8 O.D. X .051/.080 THICK FLAT WASHER (1/4) - PACK OF 10	1
516	9121010	1/4-20 X 3/4 TRUSS HEAD PHILLIPS MACHINE SCREW - PACK OF 5	1
517	6497051	BRUSH HEAD RETAINING STRAP	1
518	9121210	1/4-20 X 5/8 HEX BOLT - PACK OF 10	2
519	9120880	1/4 SPLIT LOCK WASHER - PACK OF 10	2
520	9120930	9/32 I.D. X 5/8 O.D. X .051/.080 THICK FLAT WASHER (1/4) - PACK OF 10	2
521	7691891	NSS LOGO DECAL - 3.5 X 20	1
522	6497231	SIDE PANEL	1
523	9120930	9/32 I.D. X 5/8 O.D. X .051/.080 THICK FLAT WASHER (1/4) - PACK OF 10	2
524	9120900	1/4-20 HEX NUT WITH NY-LOCK INSERT - PACK OF 10	2
525	9120520	10-24 X 5/8 TRUSS HEAD PHILLIPS MACHINE SCREW - PACK OF 10	1
526	9122260	3/8-16 X 1 HEX BOLT - PACK OF 2	2
527	9122100	3/8 SPLIT LOCK WASHER - PACK OF 10	2
528	9122180	13/32 I.D. X 13/16 O.D. X .051/.080 THICK WROUGHT WASHER (3/8) - PACK OF 10	2
529	9122260	3/8-16 X 1 HEX BOLT - PACK OF 2	2
530	9122100	3/8 SPLIT LOCK WASHER - PACK OF 10	2
531	9122260	3/8-16 X 1 HEX BOLT - PACK OF 2	2
532	9122180	13/32 I.D. X 13/16 O.D. X .051/.080 THICK WROUGHT WASHER (3/8) - PACK OF 10	2
533	9997560	VELCRO LOOP, PRESSURE SENSITIVE	4.5
534	9122100	3/8 SPLIT LOCK WASHER - PACK OF 10	2
535	9122000	3/8-16 HEX NUT - PACK OF 10	2
536	4894071	CLAMP, .437 DIAMETER CABLE, HEYCO	1
537	9120370	7/32 I.D. X 1/2 O.D. X .032/.065 THICK FLAT WASHER (#10) - PACK OF 10	1
538	9120350	10-24 HEX NUT WITH NY-LOCK INSERT - PACK OF 10	1
539	8791070	VINYL HOSE, 3/8" I.D. X 1/2" O.D.	1.3
540	3390661	TUBING CONTROL VALVE	1
541	2392481	HOSE CLAMP, 7/32" - 5/8" DIAMETER	1
542	2490601	FITTING, ELL 3/8 BARB X 1/4 NPT	1
543	6497271	BATTERY TRAY	1
544	9997550	VELCRO HOOK, PRESSURE SENSITIVE	.5
545	6497581	DECAL, BATTERY CHARGING AND WARNING	1
546	3394141	BATTERY / CHARGER WARNING DECAL	1
547	9120390	10-24 X 3/8 FLAT HEAD PHILLIPS MACHINE SCREW - PACK OF 10	4
548	7692271	LIFT HANDLE	1
549	3291111	CORD CLAMP	1

LID AND SIDE ASSEMBLY

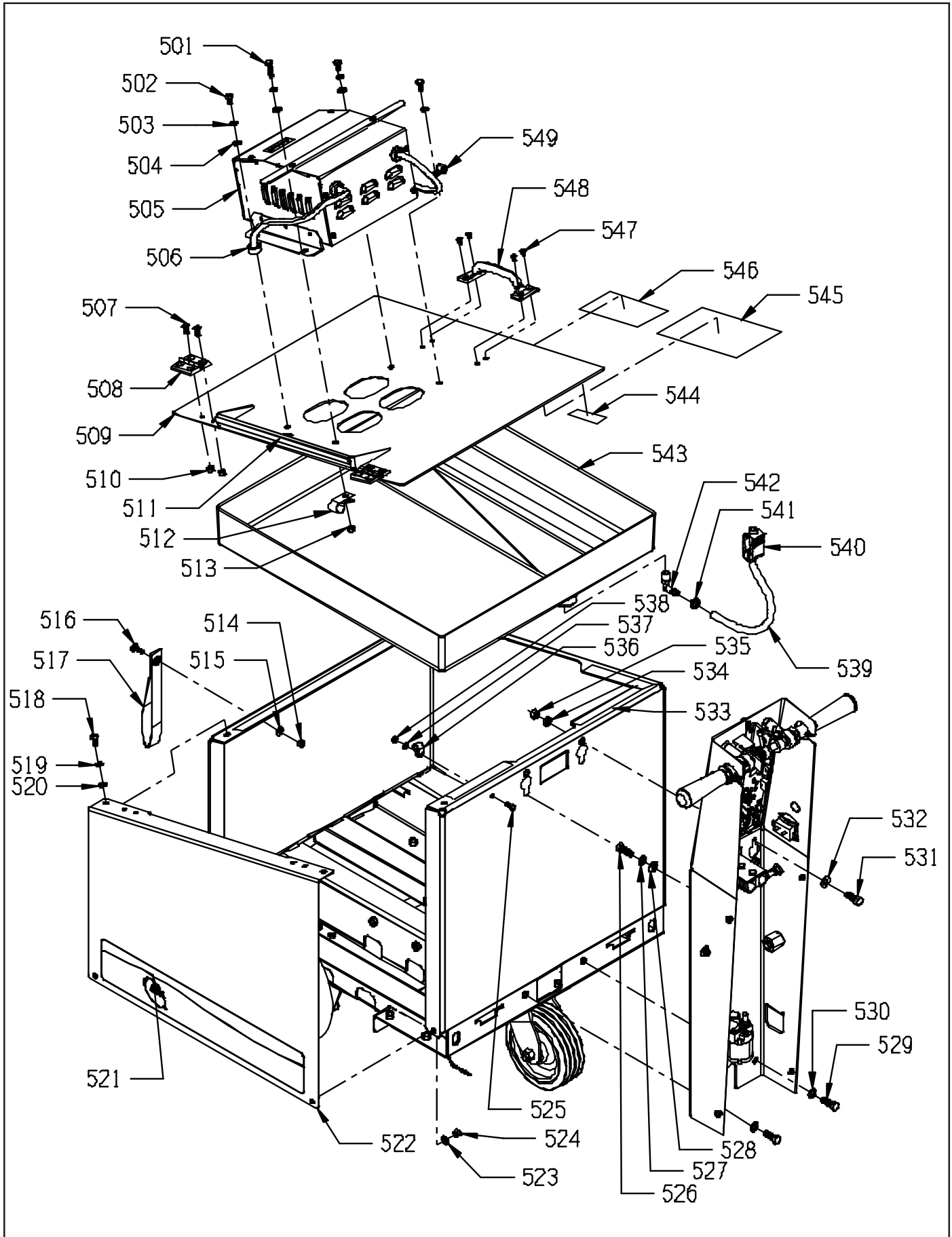

<u>ITEM</u>	<u>PART NO.</u>	<u>PART DESCRIPTION</u>	<u>QTY.</u>
44	6497441	WIRE, LIMIT SWITCH TO BRUSH SWITCH	1
66	7691661	WIRING ASSEMBLY ANDERSON TO BATTERY	1
80	6496801	WIRE HARNESS, BRUSH MOTOR	1
81	6496811	WIRE ASSEMBLY, ANDERSON - MACHINE	1
82	6496821	WIRE, BREAKER TO STANDOFF	1
83	6496831	WIRE, SOLENOID TO CONTROLLER	1
84	6496841	WIRE, CONROLLER TO STANDOFF	1
86	6497521	WIRE, SOLENOID TO AB CONTROL	1
87	6496871	WIRE, FUSE HOLDER - MASTER SWITCH	1
89	6497401	WIRE HARNESS, AB CONTROLLER - 12 PIN	1
94	6496941	WIRE, HOUR METER TO STANDOFF	1
95	6496951	WIRE, SPEED CONTROL - HOUR METER	1
98	2391981	BATTERY JUMPER 3/8" RING	5
--	4490561	INSULATED STANDOFF	1
--	4491011	SOLENOID, 36 VOLT	1
--	4491101	TOGGLE SWITCH, MOTOR	2
--	4990321	FUSE HOLDER WITH NUT & WASHER	1
--	4991371	FULLY INSULATED MALE TERMINAL 22-18	2
--	6491261	CIRCUIT BREAKER - 90 AMP	1
--	6497531	36 VOLT ON-BOARD CHARGER 25A DP - 100/115/230 50/60HZ INPUT	1
--	6495701	120 VOLT ON-BOARD CHARGER CORD	1
--	6495711	240 VOLT ON-BOARD CHARGER CORD	1
--	6496451	FAST-ACTING FUSE 2 AMP	1
--	6496721	MOTOR - 36 VOLT, 2100 RPM, 3.6HP	1
--	6497451	CONTROLLER 2717 AB (0105-0001)	1
--	6496781	TILT SWITCH	1
--	6496971	BATTERY METER WITH HARNESS	1
--	6496981	BATTERY METER DISPLAY	1
--	6496961	WIRE HARNESS, BATTERY METER - 10 PIN	1
--	6497039	KEY SWITCH KIT (OPTIONAL) - INCLUDES:	1
--	7692511	KEY SWITCH & KEY	1
02	6497021	WIRE ASSEMBLY, KEY SWITCH	1

HEAD MOTOR

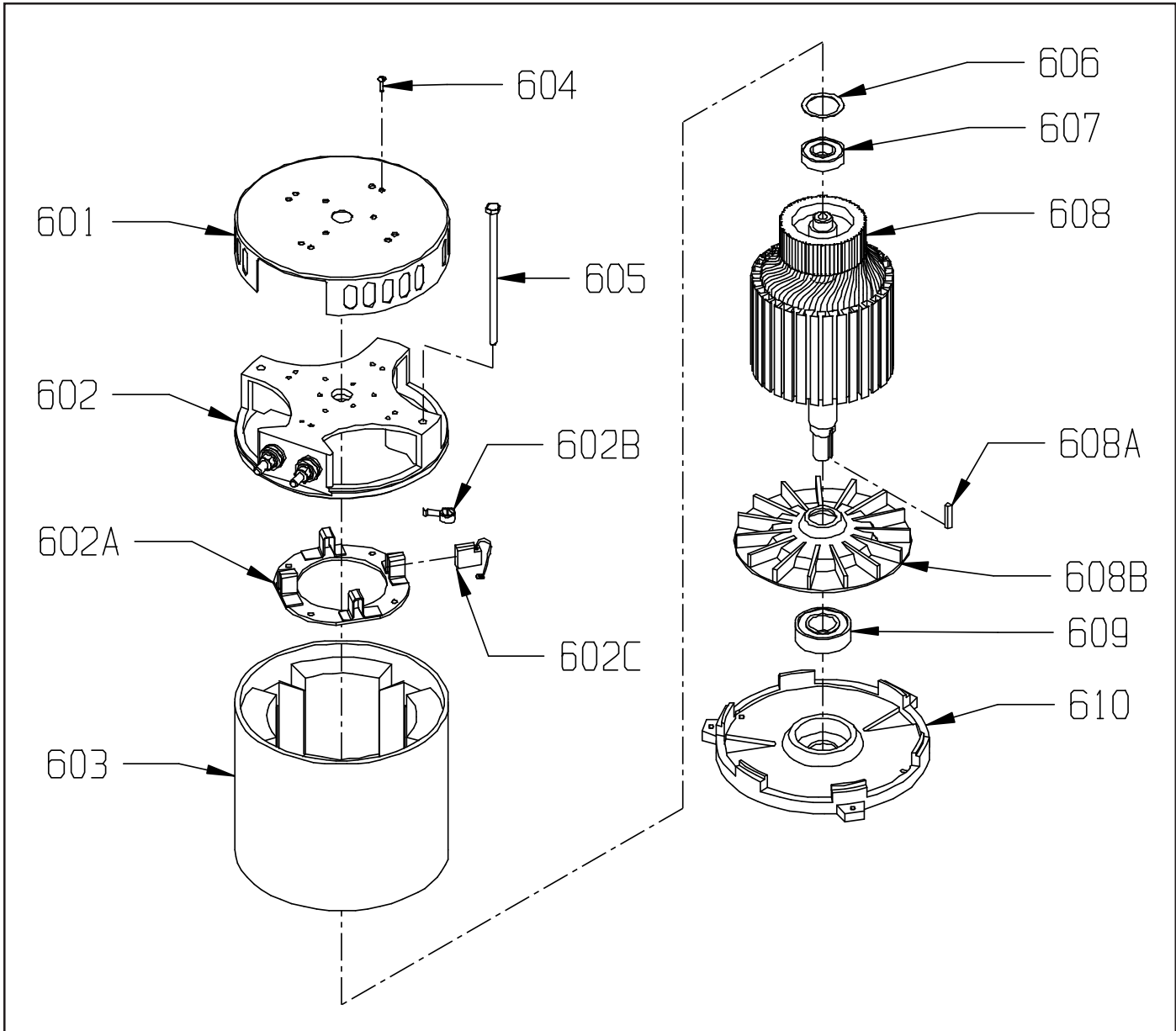

<u>ITEM</u>	<u>PART NO.</u>	<u>DESCRIPTION</u>	<u>QTY.</u>
	6496721	MOTOR 36 VOLT, 2100 RPM, 3.6 HP - INCLUDES:	1
601	5991731	COMMUTATOR BRACKET COVER	1
602	6493531	COMMUTATOR BRACKET ASSEMBLY - INCLUDES:	1
602	6493541	COMMUTATOR BRACKET	1
602A	6493601	BRUSH BOARD ASSEMBLY - INCLUDES:	1
602A1	6493591	SPRING	4
602A2	7692041	CARBON BRUSH	4
603	6493631	STATOR FRAME ASSEMBLY - WITH CLIPS AND MAGNETS - 3 HP	1
604	9120600	10-24 X 1/2 PAN HEAD PHILLIPS THREAD CUTTING SCREW - PK 10	4
605	6493621	1/4-20 X 9 HEX HEAD THRU BOLT - 3 HP	2
606	5991741	HELICAL WASHER - LARGE	1
607	5991551	BEARING - TOP END	1
608	6493651	ARMATURE - 2100 RPM - 3.6 HP - INCLUDES:	1
608A	9120827	3/16 SQUARE X 1 LONG KEY - STEEL - PACK OF 2	1
608B	6493571	ALUMINUM FAN	1
609	5991541	BEARING - BOTTOM END	1
610	6493551	END BRACKET - BOTTOM END	1

NOTES

ACCESSORIES



PART NO.

NOTE:

7992751
7992761
7992781
7992791
7992821

PART DESCRIPTION

ALL PADS COME 5 PADS PER CASE (EXCEPT TWISTER PADS)
27" LITE BLUE POLISH / BURNISH PAD - FOR SOFT FINISH
27" LITE HAIR BURNISH PAD - FOR ALL FINISHES
27" ULTRA HAIR HARD FINISH PAD - FOR HARD FINISH
27" ULTIMATE HAIR PAD - HARD FINISH AGGRESSIVE BURNISHING
27" BEIGE PLUS UHS SCRUB PAD - FOR SCUFF MARK REMOVAL

TWISTER PADS

7992701 27" TWISTER STARTER KIT
7992741 27" TWISTER RED PAD
7992731 27" TWISTER WHITE PAD
7992721 27" TWISTER YELLOW PAD
7992711 27" TWISTER GREEN PAD



NSS® Enterprises, Inc.

3115 Frenchmens Road, Toledo, Ohio 43607
PHONE (419) 531-3761 FAX (419) 531-3761
NSS® Enterprises, Inc. European Distribution Centre
Unit II, Pinfold Trading Estate * 55 Nottingham Road
STAPLEFORD, NOTTINGHAM NG9 8AD ENGLAND U.K.
PHONE: (44) 0115 939 1568 * FAX: (44) 0115 949 0615