



Electronic Service Manuals

This electronic document is provided as a service to our customers. We do not create the contents of the information contained in this document. Should you have detailed questions pertaining to the information contained in this document, you may contact Michco, or the manufacturer which provided the original information in this electronic deliverable. Michco's only part in this electronic deliverable was the electronic assembly process. By providing this manual on line we are not guaranteeing parts availability.

You may contact Michco through the following methods:

Phone (517) 484-9312 or (800) 331-3339

2011 N. High St. -- Lansing, Michigan -- 48906

Fax: (517) 484-9836

Email: CustServe@Michco.com

Web site: www.Michco.Com

Parts Web site: www.FloorMachineParts.Com

Order Parts on Line at:

www.FloorMachineParts.Com

Directly to Parts & Service:

By Email: **Shop@Michco.com**

By Fax: (517) 702-2041

By Voice: Use numbers above.

Serving the Cleaning Industry Since 1922

Notice: All copyrighted material remains property of original owners, all trademarks are property of respective owners. Manuals are subject to Manufacturer's reproduction limitations. Originals or reproductions were provided by manufacturers through a request. We make no warranty as to the correctness of information provided in this document and you assume all risk. By placing these manuals on line we are not declaring our corporation to be an manufacturer authorized dealer or provider, please check our web site for authorized manufacturers we represent.

PREDATOR CXH150

IMPORTANT SAFETY INSTRUCTIONS



**READ AND UNDERSTAND ALL INSTRUCTIONS
BEFORE OPERATING OR SERVICING MACHINE**



DANGER!

**Failure to Observe These Instructions Can Cause Personal Injury
to Machine Operator, By-standers or Possible Machine Damage.**

- **NEVER** attempt to service or perform maintenance functions while machine is plugged into an electrical outlet.
- **ALWAYS** unplug machine before attempting to service the motorized brush attachment.
- **NEVER** operate in standing water. **NEVER** expose to rain. **ALWAYS** store indoors.
- **NEVER** overfill recovery tank or allow water to enter vacuum standpipe. This will cause damage to the vacuum motor and possible electrocution.
- **NEVER** operate machine with a cut, abraded or taped cord.
- **NEVER** operate machine with a broken grounding blade on the plug.
- **ALWAYS** replace the entire cord when the cord or plug is damaged in any manner.
- **NEVER** handle the machine, cord or plug with wet hands.
- **NEVER** drop or insert any object into any machine opening.
- **ALWAYS** keep face, fingers, hair or any other body part, or loose clothing away from any machine opening or any moving part, particularly the revolving brush.
- **NEVER** leave the machine unattended when plugged in. Unplug the machine from the electrical outlet when not in use.
- **ALWAYS** turn the machine off before unplugging it from the electrical outlet.
- **NEVER** operate this machine in the presence of flammable or combustible liquids or fumes.
- When any electrical motor, switch, cord or plug service is required, maintenance should only be done by an authorized service station, an electrician or other qualified persons.
- **NEVER** operate this machine if it is not working properly, if it has been dropped, damaged, exposed to weather, or dropped into water. Return the machine to a service center for examination and repair.
- **NEVER** operate this machine with any air opening blocked. Keep all air openings free of dust, lint, hair, ect.
- **NEVER** operate this machine without solution tank filter screens or vacuum standpipe filter screen in place or if they are clogged. Clean all filter screens after every use.
- **ALWAYS** store this machine indoors. Protect it from rain or snow.
- **NEVER** spray the top of the machine with liquids.
- **DO NOT** pull or carry this machine by the electrical supply cord, use the cord as a handle, close a door on the cord, pull the cord around sharp edges or corners, or expose to heated surfaces.
- **NEVER** disconnect the plug by pulling on the cord. To disconnect the cord from the outlet grasp the plug, not the cord.
- **ALWAYS** unplug this machine before attempting to service.
- **ALWAYS** use a defoamer which will prevent a buildup of foam in the recovery tank. If a defoamer is not used, the motor can be damaged from shampoo being pulled into the vacuum motor.

SAVE THESE INSTRUCTIONS



INFORMATION & OPERATING INSTRUCTIONS

**DO NOT OPERATE MACHINE UNTIL YOU HAVE READ THIS SECTION
IMPROPER USE OF THE PREDATOR CHX150 WILL VOID THE WARRANTY**

1. Always use a rag to prevent burns when handling quick-disconnects.
2. Always use a defoamer when foaming occurs to prevent vacuum motor damage.
3. To keep fitting and lines from damage during freezing conditions, use an anti-freeze in the pump and heater or keep equipment inside heated areas.
4. Do not let pump run dry.
5. Use neutral pH, water-based products only - NO SOLVENTS!

INSPECTION:

Carefully unpack and inspect the PREDATOR CXH150 for shipping damage. Each unit is tested and inspected before shipment. Any damage incurred is the responsibility of the carrier, who should be notified immediately.

CLEANING SOLUTIONS:

We recommend liquid cleaning chemicals. Powders may be used, but unless mixed very thoroughly, they could cause build-up in the lines, pump, quick-disconnects, etc. A pH of 7-9 is strongly recommended to avoid premature pump wear, which would void the warranty.

MAINTENANCE:

For optimum performance, flush the machine with clear water at the end of each working day. Once a month, minimum, run a flushing compound through the machine to cut any alkaline build-up that may have formed.

Lubricate wheels, casters and hinges as needed. The pump and vacuum motors do not require any maintenance.

The body can be cleaned with a general all-purpose detergent and protected with a silicone type product like Armor All®. The quick-disconnects should be lubricated with silicone, also.

Prior to each job, inspect the holding tank filter and the recovery tank float filter for hair and dirt. The drain valve should also be inspected regularly and kept free of any debris or build-up.

SET-UP:

Fill the holding tank with clear water and the detergent of your choice. Mix well. Although this machine is designed to supply instant hot water, the addition of warm or hot water to the holding tank would be a plus factor.

1. Plug in cord #1, identified by the 4" long red band on the end of the cord. (This cord runs the pump and vacuums).
2. Turn on the pump and spray through the cleaning tool for a few seconds to fill the lines with solution.
3. Plug in cord #2. IF THE GREEN LIGHT ILLUMINATES, THE HEAT EXCHANGER WILL TURN ON AUTOMATICALLY (SEE NOTE BELOW). Wait 2 minutes for the heat exchanger to reach operating temperature. You may now begin cleaning. It will take about 10 seconds for the initial heat to reach the wand.

NOTE: If the green circuit indicator light does not illuminate when cord #2 is plugged in, then both cords are on the same circuit. Try other outlets until the light comes on. See bypass switch section (below) if you are unable to get a green light.

BYPASS SWITCH:

The bypass switch completely bypasses the circuit locator. Use this feature when you cannot get the green light to come on and you believe that the two cords are on separate circuit breakers.

CAUTION: If the bypass switch is on and the two cords are plugged into the same circuit breaker, the breaker will blow.

ELECTRIC CIRCUIT LOCATOR:

This unique, patented "smart system", operated by a solid state circuit, will inform the operator when the two cords are plugged into separate lines by illuminating the green indicator light. This helps prevent tripping circuit breakers.

BALL FLOAT VACUUM SHUTOFF:

When the recovery tank is full, the ball float system will shut off the incoming air flow and prevent water from entering the vac motor(s). The float will not work in heavy foam. Always use a defoamer to prevent overflow. Once the float is activated, the vac switches must be turned off and the recovery tank emptied.

CAUTION: To avoid vac motor damage, always make sure the filter is clean and the float travels freely before turning on the machine. Use a defoamer whenever foam is present. Water damage to the vac motors is not covered by the warranty.

SAFETY PRECAUTIONS:

All extension cords must have a rating of at least 12/3 (#12 cord). Extension cords should be no longer than 50 feet. Replace the plug immediately if the ground prong becomes damaged or is broken off. Not only is the ground necessary for safety, but the circuit locator system will not operate correctly without it.

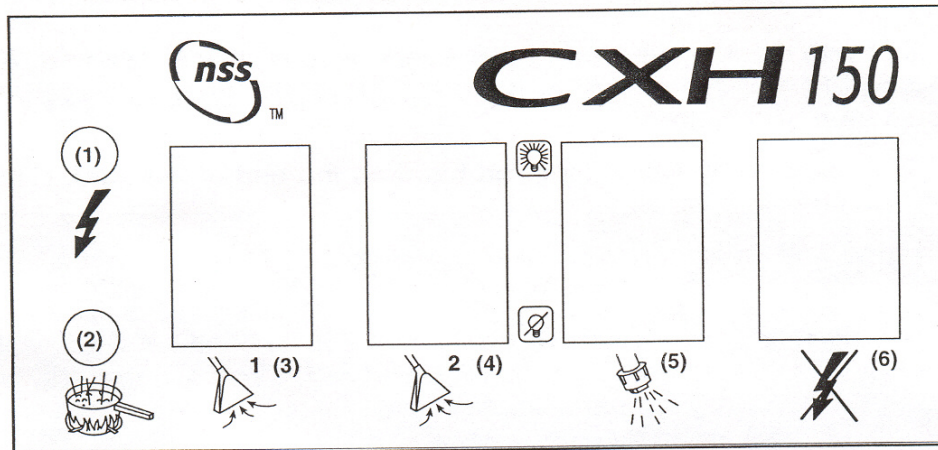

CIRCUIT LOCATOR (1): When this light is on, it indicates that cord #2 is on a separate line from cord #1. Cord #2 supplies voltage to the heater allowing it to heat to the proper temperature range.

HEAT MODE LIGHT (2): This light will only illuminate when the heater is heating and will turn off when it reaches operating temperature.

VACUUM SWITCH (3 & 4): Each switch turns on one vac motor. Turn both switches on for maximum lift. The vac switches illuminate when turned on.

PUMP SWITCH (5): This switch will illuminate when the pump is on.

BYPASS SWITCH (6): The bypass switch will illuminate when it is activated and will completely bypass the circuit locator. Use this feature only when the circuit locator light will not operate and you know each cord is on a separate circuit breaker.

CAUTION: WHEN THE BYPASS SWITCH IS ON, THE CIRCUIT BREAKER CAN BLOW IF BOTH CORDS ARE ON THE SAME CIRCUIT.

COMMON STAINS AND CLEANING TREATMENTS

TREATMENT METHODS

- First: Remove excess material by blotting to absorb liquids, or by scraping with a dull edge (butter knife) if a solid.
- Second: Clean the remaining stain as directed by the chart below. Always follow the direction on the container. Apply the cleaning material directly to the stain (avoid over wetting the carpet or upholstery), then remove the loosened stain material with a white absorbent cloth or tissue.
- Third: When the carpet is dry, gently brush the carpet pile to restore its appearance.
- Note: Treat unknown stains with a volatile solvent first and follow with other agents as required. If you are uncertain of the effect of the cleaning agent on the carpet fiber or dye, test on an inconspicuous area first.

STAIN TYPE

TREATMENT MATERIAL

Asphalt	Volatile solvent/detergent
Beer	Liquid detergent, White vinegar
Berry stain	Liquid detergent, Ammonia 3-6%, Water
Bleach	Liquid detergent, Water
Blood (dried)	Warm detergent, Ammonia 3-6%, Water
Blood (wet)	Liquid detergent, Water
Butter	Volatile solvent
Catsup or Mustard	Liquid detergent
Chewing gum	Volatile solvent
Chocolate	Liquid detergent, Ammonia water
Coffee	Detergent, White vinegar, Volatile solvent
Cola drink	Liquid detergent
Creme de Menthe (green)	Liquid detergent
Egg (raw)	Liquid detergent
Food dye	Liquid detergent, Water
Furniture dye or polish	Paint/Oil/Grease remover, Detergent
Gravy	Liquid detergent
Lipstick	Paint/Oil/Grease remover
Mascara	Paint remover, Volatile solvent, Detergent, Water
Milk	Liquid detergent
Orange drink	Liquid detergent, Water
Shoe polish	Heated iron into clean towel, Volatile solvent
Tea	Liquid detergent
Tomato Juice	Liquid detergent
Urine	Liquid detergent, Water
Vomit	Warm detergent, Water, White vinegar
Wine	Liquid detergent, Ammonia 3-6%, Water, Vinegar

PREDATOR CXH150

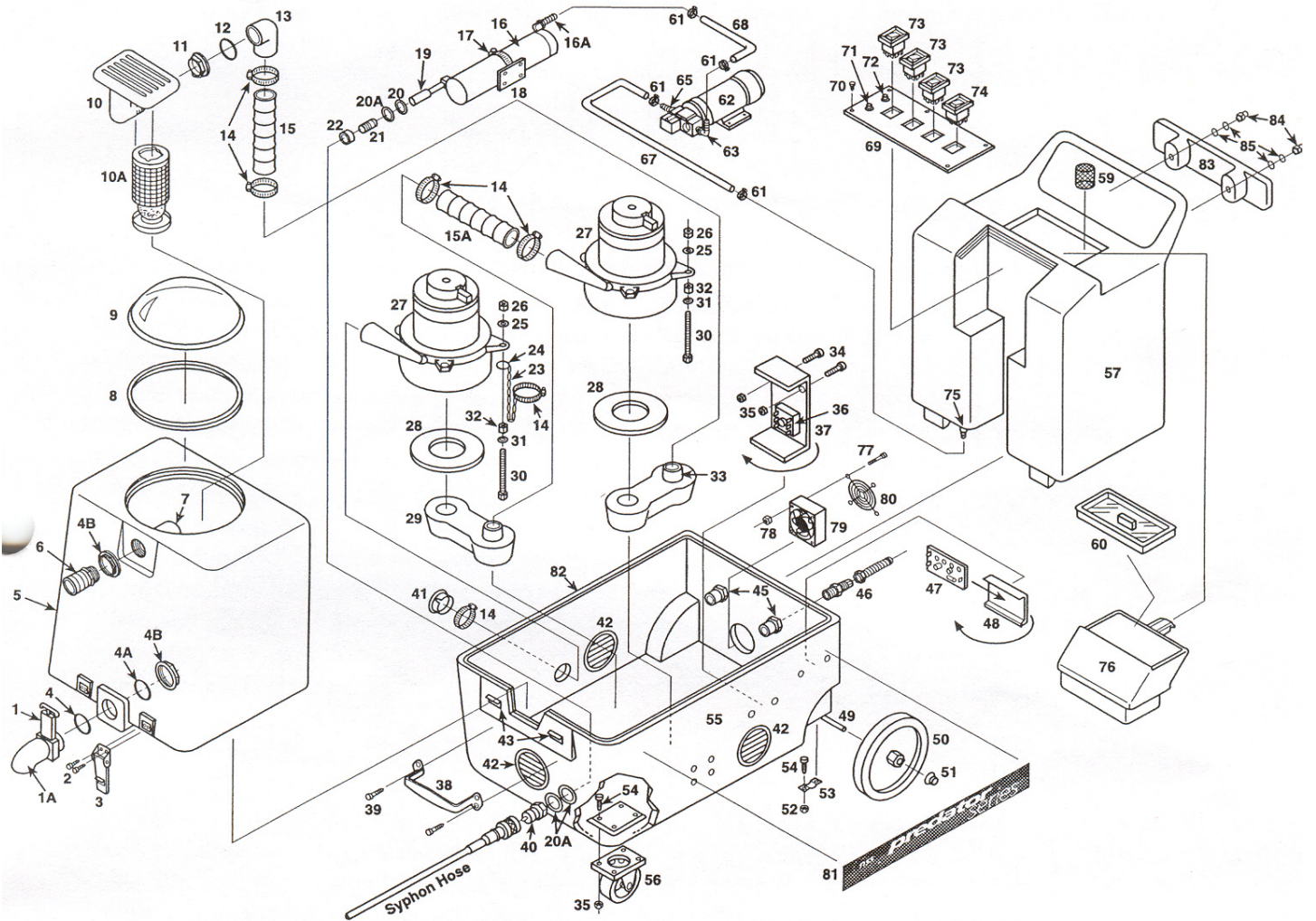

PREDATOR CXH150 WIRING DIAGRAM 120V

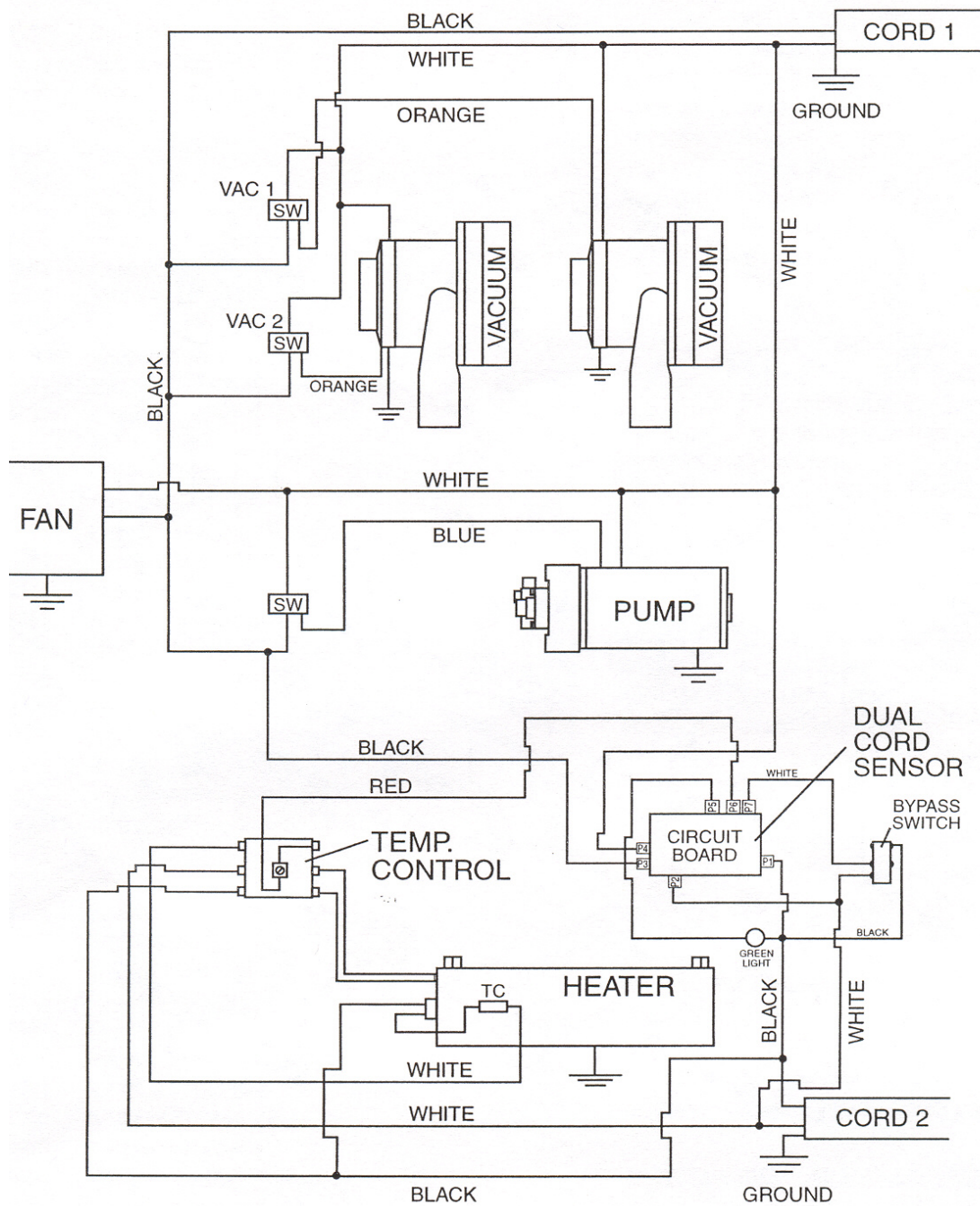

6/27/01



NSS ENTERPRISES, INC.

3115 Frenchmens Road, Toledo, Ohio 43607
PHONE: 419-531-3761 ■ FAX: 419-531-3761

TM

NSS® Enterprises, Inc. European Distribution Centre
Unit II, Pinfold Trading Estate 55 Nottingham Road
STAPLEFORD, NOTTINGHAM NG9 8AD ENGLAND U.K.