



## Electronic Service Manuals

This electronic document is provided as a service to our customers. We do not create the contents of the information contained in this document. Should you have detailed questions pertaining to the information contained in this document, you may contact Michco, or the manufacturer which provided the original information in this electronic deliverable. Michco's only part in this electronic deliverable was the electronic assembly process. By providing this manual on line we are not guaranteeing parts availability.

You may contact Michco through the following methods:

Phone (517) 484-9312 or (800) 331-3339

2011 N. High St. -- Lansing, Michigan -- 48906

Fax: (517) 484-9836

Email: [CustServe@Michco.com](mailto:CustServe@Michco.com)

Web site: [www.Michco.Com](http://www.Michco.Com)

Parts Web site: [www.FloorMachineParts.Com](http://www.FloorMachineParts.Com)

Order Parts on Line at:

**[www.FloorMachineParts.Com](http://www.FloorMachineParts.Com)**

Directly to Parts & Service:

By Email: **[Shop@Michco.com](mailto:Shop@Michco.com)**

By Fax: (517) 702-2041

By Voice: Use numbers above.

**Serving the Cleaning Industry Since 1922**

Notice: All copyrighted material remains property of original owners, all trademarks are property of respective owners. Manuals are subject to Manufacturer's reproduction limitations. Originals or reproductions were provided by manufacturers through a request. We make no warranty as to the correctness of information provided in this document and you assume all risk. By placing these manuals on line we are not declaring our corporation to be an manufacturer authorized dealer or provider, please check our web site for authorized manufacturers we represent.

# WRANGLER 20 E

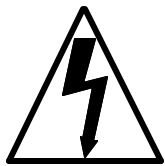

## IMPORTANT SAFETY INSTRUCTIONS

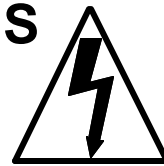

READ AND UNDERSTAND ALL INSTRUCTIONS  
BEFORE OPERATING OR SERVICING MACHINE

**DANGER!** Failure to Observe These Instructions Can Cause Personal Injury to Machine Operator, By-standers or Possible Machine Damage.

- \* **NEVER** attempt to operate this machine unless you have been trained in its operation.
- \* **NEVER** allow an untrained person to operate this machine.
- \* Use this machine **ONLY** as described in this manual.
- \* **NEVER** attempt to operate this machine if it is not working properly or has been damaged in any manner.
- \* **NEVER** disconnect or modify any switch or safety device (circuit breaker) on this machine.
- \* **ALWAYS** operate this machine from the rear control panel, not from the side.
- \* **NEVER** drop or insert any object into any machine opening.
- \* **ALWAYS** keep face, fingers, hair or any body part, or loose clothing away from any machine opening or moving part (revolving brush, pad driver, or vacuum motor).
- \* **NEVER** operate this machine with any air opening blocked. Keep all air openings free of dust, lint, hair etc.
- \* **NEVER** spray this machine with water or any liquids.
- \* **NEVER** allow the vacuum motor or battery charging plug to get wet. The vacuum motor and battery charging plug will short out if wet.
- \* **NEVER** operate this machine in an explosive atmosphere (grain dust, flammable liquids or fumes).
- \* **NEVER** use flammable liquids (gas, kerosene, solvents or thinners) to clean floor.
- \* **ALWAYS** turn the brush switch **OFF** when attaching pads or brushes.
- \* **NEVER** operate this machine with the splash skirt removed.
- \* **NEVER** leave this machine unattended.
- \* **ALWAYS** store this machine indoors in a dry, cool area.

**PERSONAL INJURY AND PROPERTY DAMAGE FROM THIS MACHINE OVERTURNING, BATTERIES FALLING OUT OF THE MACHINE OR BATTERIES LEAKING ACID CAN OCCUR IF YOU DO NOT FOLLOW THESE PRECAUTIONS:**

- \* **ALWAYS** be sure that the ramp is secured to the vehicle before attempting to load / unload.
- \* **ALWAYS** use extreme caution when operating this machine on a ramp or loading / unloading this machine into or out of a truck. Use extreme caution if the ramp is wet, oily or covered with cleaning chemicals.
- \* **NEVER** turn this machine on an ramp or incline.
- \* **NEVER** stop this machine on a ramp or incline.
- \* **NEVER** attempt to climb a grade or operate this machine on a ramp or incline of more than 20 degrees.
- \* **NEVER** park or store this machine near a dock, on ramps, near a furnace, boiler, open flame, or other high heat source.
- \* **NEVER** allow this machine to freeze.
- \* **NEVER** store any items on this machine.

**ALL** repair service must be performed by an NSS authorized distributor/service station. Use only NSS original equipment parts.

**SAVE THESE INSTRUCTIONS**



# **DANGER:** DO NOT ATTEMPT MAINTENANCE OR REPAIRS BEFORE DISCONNECTING CORD FROM ELECTRICAL POWER SOURCE. READ ALL INSTRUCTIONS AND FOLLOW ALL ILLUSTRATIONS CAREFULLY.

## **GROUNDING INSTRUCTIONS**

This machine must be grounded. If it should malfunction or break down, grounding provides a path of least resistance for electric current to reduce the risk of electric shock. This machine is equipped with a cord having an equipment-grounding conductor and grounding plug. The plug must be plugged into an appropriate outlet that is properly installed and grounded in accordance with all local codes and ordinances.

**DANGER** - Improper connection of the equipment-grounding conductor can result in a risk of electric shock. Check with a qualified electrician or service person if you are in doubt as to whether the outlet is properly grounded. Do not modify the plug provided with the machine - if it will not fit the outlet, have a proper outlet installed by a qualified electrician.

Follow grounding sequence of assembly as shown to ground machine and ensure safety to operator.

**FAILURE TO DO SO MAY CAUSE ELECTROCUTION** due to improper connection of ground.

Check nameplate on machine to be sure voltage and cycle stated on nameplate is the same as voltage and cycle of electrical outlet. DO NOT attempt to plug a 115 volt machine into a 240 volt outlet or a 240 volt machine into a 115 volt outlet.

The grounding blade on the plug must remain intact if the machine is to be properly grounded when plugged in and operated. An ungrounded machine can cause shock to the operator. See Figure A.

If connecting to an outlet that accepts only two blades use an adapter as in Figure B. **NEVER REMOVE THE GROUNDING BLADE.**

If it is necessary to use the adapter shown in Figure B, the machine is only properly grounded if the adapter's green colored clip is tied under a metal screw that holds electrical outlet cover to the wall.

Figure C. Machine used on 240 volt may or may not have the grounding (earthed) plug attached to the cord. For U.S.A. 240 volt 60 HZ, the plug is already supplied with cord. For use outside the U.S.A., it may be up to the purchaser to have a proper grounding (earthed) plug attached.

When grounding blade on plug is broken, it is preferable to replace the whole cord.

Replacement cords must be U.L. Listed/CSA approved and be of the identical electrical specifications as the original equipment cord.

If you choose to replace 3-wire plug for 115 Volt use only U.L. Listed/CSA approved plug with rating of 125 Volt 15 amps (for 240 Volt use a 3-wire plug with rating consistent with voltage and amps required). Be sure that the green wire of the cord is connected to the green screw, and the black wire to gold screw of the replacement plug.

**ALWAYS** remember when replacing plug, that if the grounding wire (green) is connected to a live terminal at the machine or plug, the machine will become electrically charged and will result in electrical shock or electrocution.

Always use a properly grounded 3-wire extension cord which has male and female plugs. Use only 14-3 ST or SO type extension cord for a total cord length up to 100 feet.

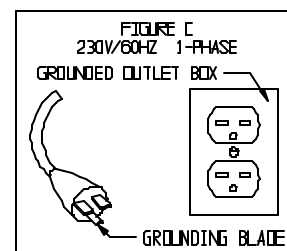
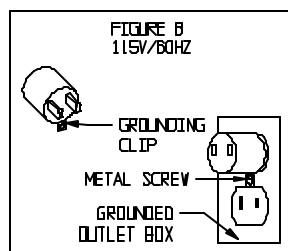
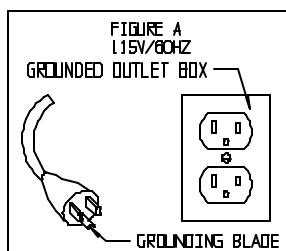

NOTE: IN CANADA, THE USE OF A TEMPORARY ADAPTOR IS NOT PERMITTED BY CANADIAN ELECTRICAL CODE.

# SOLUTION TANK ASSEMBLY

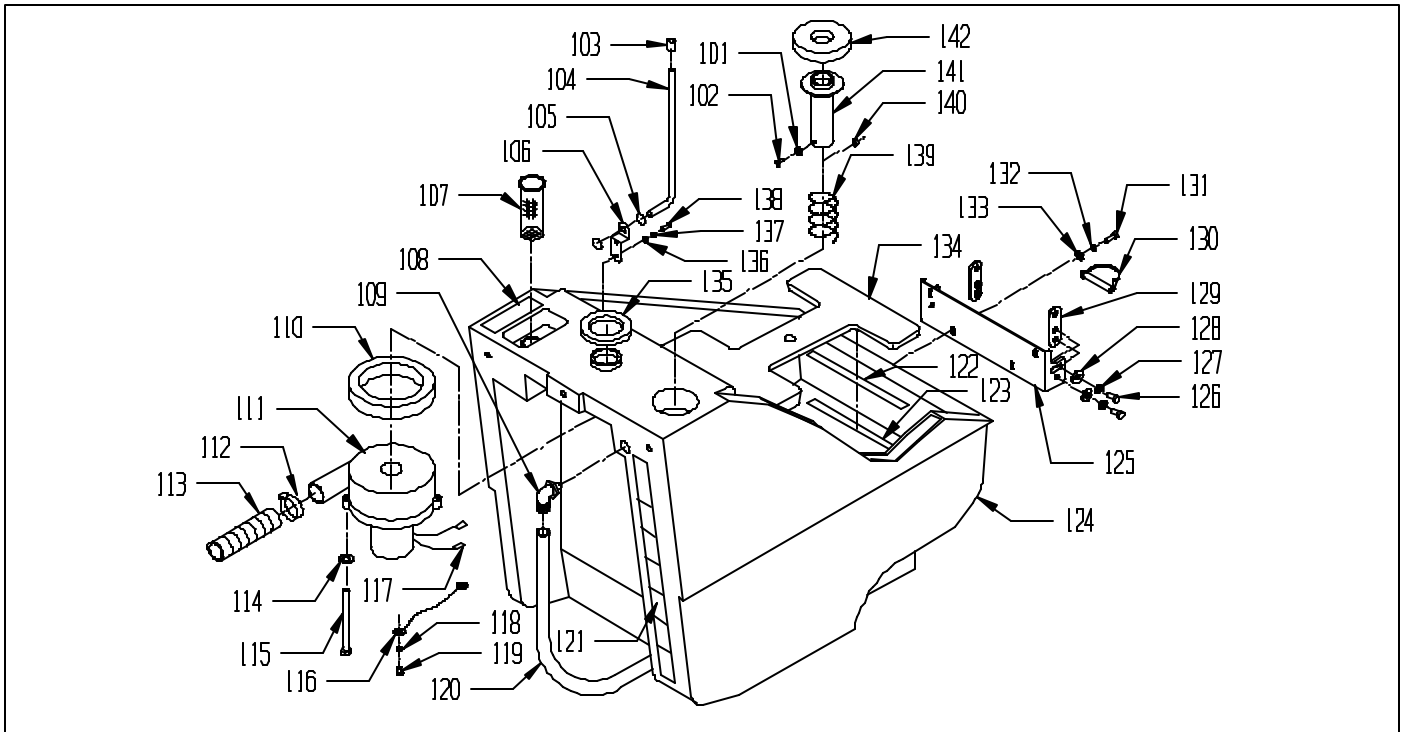

ITEM	PART NO.	DESCRIPTION	QTY
101	91-2-032-0	#10 SPLIT LOCK WASHER	1
102	91-2-038-0	10-24 X 3/8 ROUND HEAD PHILLIPS MACHINE SCREW	1
103	50-9-253-1	SOLUTION FEED TUBE CAP	1
104	23-9-163-6	HOOD ROD	1
105	23-9-256-1	CIRCLE COTTER PIN - #CC-7	2
106	23-9-164-6	ROD BRACKET	1
107	27-9-189-9	SOLUTION TANK, FILTER	1
	27-9-189-1	BAG, TANK SCREEN	1
	27-9-176-1	RING	1
108	23-9-217-1	CLEAN WATER TANK DECAL	1
109	23-9-177-1	90 DEGREE HOSE BARB	1
110	46-9-010-1	VACUUM MOTOR / FLOAT GASKET	1
111	23-9-107-1	VACUUM MOTOR 120 VOLT	1
	23-9-258-1	VACUUM MOTOR CARBON BRUSH 120 VOLT	2
	23-9-109-1	VACUUM MOTOR 240 VOLT	1
	23-9-259-1	VACUUM MOTOR CARBON BRUSH 240 VOLT	2
112	44-9-544-1	HOSE CLAMP 1 9/16" TO 2 1/2" DIAMETER	1
113	23-9-565-1	VACUUM MOTOR EXHAUST HOSE	1
114	91-2-088-0	1/4 SPLIT LOCK WASHER	3
115	49-9-119-1	1/4-20 X 3 HEX BOLT	3
116	32-9-069-1	GREEN WIRE GROUND TO MOTOR	1
117	54-9-017-1	1/4 MALE SPADE TERMINAL FULLY INSULATED	2
118	91-2-032-0	#10 SPLIT LOCK WASHER	1
119	91-2-059-0	10-24 X 3/8 PAN HEAD PHILLIPS THREAD CUTTING SCREW	1
120	23-9-599-7	VINYL HOSE 3/4" I.D. X 33" LONG	1
121	23-9-185-1	SOLUTION LABEL	1
122	99-9-755-0	VELCRO HOOK, P.S.	1'
123	99-9-756-0	VELCRO LOOP, P.S.	1'
124	23-9-101-1	SOLUTION TANK	1
125	23-9-594-3	LOWER HINGE BRACKET	1
	23-9-168-9	LOWER HINGE ASSEMBLY (INCL. ITEMS 125-129)	1
126	91-2-121-0	1/4-20 X 5/8 HEX BOLT	4
127	91-2-088-0	1/4 SPLIT LOCK WASHER	4
128	91-2-093-0	9/32 I.D. X 5/8 O.D. X .051/.080 THICK SAE FLAT WASHER (1/4)	4
129	23-9-593-3	ADJUSTMENT PLATE - HINGE BRACKET	2
130	23-9-165-1	3/8 X 1 5/8 CLEVIS PIN - STEEL, ZINC PLATE (W/RETAINER)	2
131	91-2-125-0	1/4-20 X 3/4 HEX BOLT WITH NYLON PATCH	4
132	91-2-088-0	1/4 SPLIT LOCK WASHER	4
133	91-2-093-0	9/32 I.D. X 5/8 O.D. X .051/.080 THICK SAE FLAT WASHER (1/4)	4
134	23-9-196-3	CAST IRON WEIGHT	1
135	02-9-434-1	TOP MOTOR SEAL - NEOPRENE	1
136	91-2-093-0	9/32 I.D. X 5/8 O.D. X .051/.080 THICK SAE FLAT WASHER (1/4)	2
137	91-2-088-0	1/4 SPLIT LOCK WASHER	2
138	91-2-117-0	1/4-20 X 1/2 HEX BOLT	2
139	23-9-158-1	SPRING, TUBE ADAPTOR	1
140	91-2-036-0	10-24 HEX NUT WITH STAR LOCK WASHER	1
141	23-9-157-3	TUBE ADAPTER	1
142	23-9-159-1	GASKET TUBE ADAPTER	1

## **WHEEL AND VALVE ASSEMBLY**

<u>ITEM</u>	<u>PART NO.</u>	<u>DESCRIPTION</u>	<u>QTY</u>
201	23-9-101-1	SOLUTION TANK	1
202	23-9-177-1	90 DEGREE HOSE BARB	1
203	23-9-599-7	VINYL HOSE 3/4" I.D. X 33" LONG	1
204	23-9-531-3	SOLUTION VALVE BRACKET	1
205	23-9-547-1	VALVE LEVER (SHORT)	1
206	91-2-153-1	5/16-24 HEX NUT	1
207	91-2-089-0	1/4-20 THIN HEX NUT WITH NY-LOK INSERT	1
208	91-2-152-0	5/16 SPLIT LOCK WASHER	2
209	91-2-164-0	5/16-18 X 3/4 HEX BOLT	2
210	23-9-118-1	VALVE LEVER GRIP	1
211	26-9-028-3	SOLUTION VALVE LEVER	1
212	23-9-574-3	SQUEEGEE MOUNT BRACKET	1
213	91-2-125-0	1/4-20 X 3/4 HEX BOLT WITH NYLON PATCH	1
214	91-2-088-0	1/4 SPLIT LOCK WASHER	1
215	91-2-093-0	9/32 I.D. X 5/8 O.D. X .051/.080 THICK SAE FLAT WASHER (1/4)	1
216	27-9-128-6	BUSHING SPACER	1
217	26-9-258-1	4" GRAY SOFT CASTER COMPLETE	1
	44-9-049-1	REPLACEMENT SOFT CASTER WHEEL ONLY	1
	44-9-050-1	RED WHEEL 4" CASTER COMPLETE	1
	44-9-039-1	REPLACEMENT RED CASTER WHEEL ONLY	1
218	91-2-210-0	3/8 SPLIT LOCK WASHER	4
219	91-2-235-0	3/8-16 X 3 HEX BOLT	4
220	91-2-226-0	3/8-16 X 1 HEX BOLT	2
221	91-2-210-0	3/8 SPLIT LOCK WASHER	2
222	91-2-140-0	13/32 I.D. X 13/16 O.D. X .051/.080 THICK WROUGHT WASHER (3/8)	2
223	23-9-193-1	WHEEL, 8" W/GROOVES	2
224	52-9-341-1	3/4 I.D. X 1 1/4 O.D. X .071/.082 THICK FLAT WASHER (14 GAGE)	1
225	91-2-245-0	17/32 I.D. X 1 1/16 O.D. X .074/.121 THICK SAE FLAT WASHER (1/2)	4
226	91-2-242-0	1/2 SPLIT LOCK WASHER	4
227	91-2-250-0	1/2-13 X 7/8 HEX BOLT	4
228	91-2-085-0	1/4-20 X 5/16 SET SCREW - KNURL POINT	2
229	23-9-569-3	RIGHT AXLE SUPPORT BRACKET	1
230	23-9-141-6	AXLE	1
232	91-2-198-0	7/16 I.D. X 1 O.D. X .075/.080 THICK SAE FLAT WASHER (3/8)	4
233	52-9-354-1	13/32 I.D. X 1 O.D. X .12 THICK FLAT WASHER (11 GAGE)	4
234	23-9-568-9	LIFT FORK ASSEMBLY (INCL, ITEMS 234, 235, 240)	1
	23-9-568-3	LIFT FORK	1
235	27-9-137-1	FLANGE BEARING FF-838-3	2
236	91-2-254-0	1/2-13 X 1 1/4 HEX BOLT	2
237	91-2-242-0	1/2 SPLIT LOCK WASHER	2
238	91-2-245-0	17/32 I.D. X 1 1/16 O.D. X .074/.121 THICK SAE FLAT WASHER (1/2)	2
239	27-9-075-6	BUSHING SPACER	2
240	27-9-076-1	FLANGE BEARING, FF-71	2
241	23-9-177-1	90 DEGREE HOSE BARB	1
242	23-9-214-1	HOSE CLAMP, 11/16" TO 1 1/4" DIAMETER	1
243	23-9-185-1	SOLUTION LABEL	1
244	23-9-576-1	CLAMP, TUBE	1
245	91-2-152-0	5/16 SPLIT LOCK WASHER	1
246	91-2-164-0	5/16-18 X 3/4 HEX BOLT	1
247	23-9-598-7	VINYL HOSE 3/8" I.D. X 23" LONG	1
248	38-9-066-1	HOSE BARB 1/4 MPT	1
249	13-9-153-1	SOLUTION VALVE	1
250	27-9-179-1	90 DEGREE HOSE BARB - 1/4 NPT	1
251	23-9-597-7	VINYL HOSE 3/8" I.D. X 14" LONG	1
252	91-2-250-0	1/2-13 X 7/8 HEX BOLT	1
253	91-2-242-0	1/2 SPLIT LOCK WASHER	1
254	91-2-245-0	17/32 I.D. X 1 1/16 O.D. X .074/.121 THICK SAE FLAT WASHER (1/2)	1
255	23-9-532-3	CHANNEL, DRIVE CASTER	1
256	23-9-248-1	HOSE CLAMP, 7/32" TO 5/8" DIAMETER	3
257	24-9-060-1	FITTING, ELL 3/8 BARB X 1/4 MNPT	1

# WHEEL AND VALVE ASSEMBLY

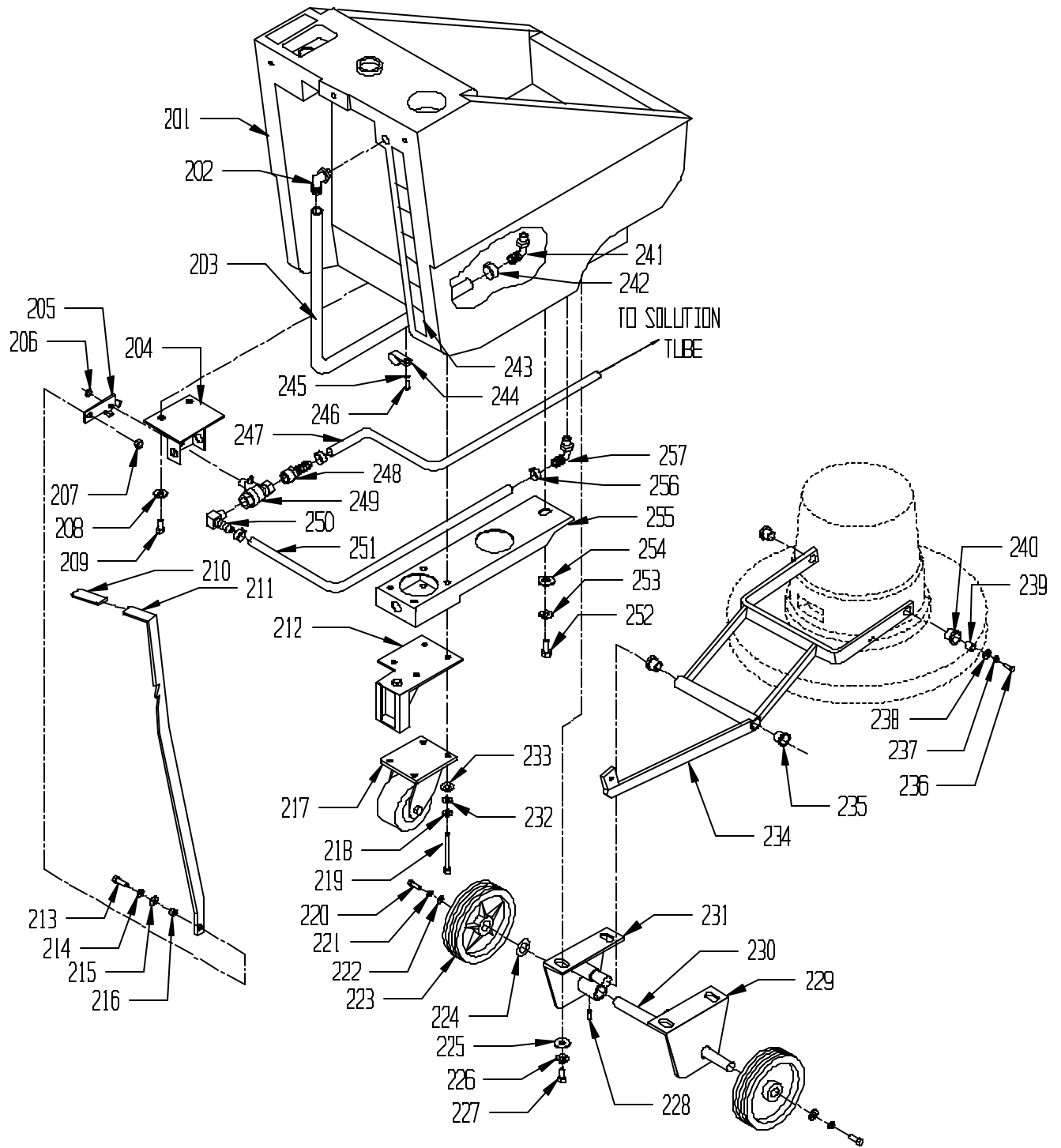

## **RECOVERY TANK ASSEMBLY**

<u>ITEM</u>	<u>PART NO.</u>	<u>DESCRIPTION</u>	<u>QTY</u>
301	22-9-121-1	5" ALUMINUM CONNECTOR	1
302	23-9-124-1	HOSE STRAP	1
303	57-9-701-1	TOOL - SQUEEGEE W/WHEELS, 15"	1
304	44-9-052-1	LOAD ADJUST KNOB	1
305	91-2-064-0	10-32 X 1/4 SET SCREW - CUP POINT	1
306	23-9-178-1	WARNING / OPERATE LABEL	1
307	23-9-566-1	TANK DRAIN LABEL	1
308	23-9-545-1	VACUUM TUBE	1
309	23-9-161-1	INLET TUBE GASKET	1
310	91-2-093-0	9/32 I.D. X 5/8 O.D. X .051/.080 THICK SAE FLAT WASHER (1/4)	3
311	91-2-097-1	1/4 EXTERNAL STAR LOCK WASHER	3
312	91-2-100-0	1/4-20 X 5/8 TRUSS HEAD PHILLIPS MACHINE SCREW	3
313	23-9-160-1	VACUUM TUBE GASKET	1
314	23-9-161-1	INLET TUBE GASKET	2
315	23-9-154-1	FLOAT SCREEN ASSEMBLY	1
316	23-9-156-3	INLET TUBE	1
317	48-9-267-1	HOSE CLAMP, 1 1/16" TO 2"	1
318	23-9-162-6	STUD, HOOD KNOB	1
319	91-2-097-1	1/4 EXTERNAL STAR LOCK WASHER	3
320	91-2-100-0	1/4-20 X 5/8 TRUSS HEAD PHILLIPS MACHINE SCREW	3
321	27-9-188-1	PLUG STRAP	1
322	27-9-562-1	DRAIN PLUG	1
323	23-9-166-6	HOSE TUBE	1
324	23-9-216-1	TUBE HOSE CLAMP, CRIMP-ON TYPE	1
325	23-9-175-1	1/8" X 5/8" DOME HEAD POP RIVET - STEEL	2
326	23-9-213-1	SPRING CLIP, HOSE	1
327	23-9-167-1	DRAIN HOSE, CRUSH PROOF	1
328	23-9-169-3	UPPER HINGE	1
329	91-2-088-0	1/4 SPLIT LOCK WASHER	4
330	91-2-121-0	1/4-20 X 5/8 HEX BOLT	4
331	44-9-544-1	HOSE CLAMP, 1 9/16 TO 2 1/2 DIA.	1
332	23-9-187-1	"E" LABEL	2
333	23-9-181-1	RIGHT SIDE LABEL	1
	23-9-180-1	LEFT SIDE LABEL	1
334	23-9-544-1	RECOVERY TANK	1
335	27-9-196-1	BATTERY COVER LABEL - NSS / HORSE	1
336	23-9-587-7	VELCRO HOOK, P.S. X 2"	2
337	91-2-036-0	10-24 HEX NUT WITH STAR LOCK WASHER	2
338	26-9-089-1	RECOVERY TANK LID GASKET	1
339	26-9-093-1	LID CHAIN RECOVERY TANK	1
340	26-9-092-1	LID MOUNTING RING	1
341	91-2-045-0	10-24 X 1 ROUND HEAD PHILLIPS MACHINE SCREW	1
342	91-2-079-0	10 X 5/8 PAN HEAD PHILLIPS SHEET METAL SCREW	5
343	26-9-088-1	RECOVERY TANK LID ASSEMBLY (INCL. ITEMS 339, 340, 344)	1
	26-9-088-9	RECOVERY TANK LID & GASKET ASSY. (INCL. ITEMS 338-340, 344)	1
344	26-9-091-1	CLEAR TANK LID	1
345	23-9-589-7	VELCRO LOOP, P.S. X 6"	2
346	23-9-123-1	VACUUM HOSE	1
347	57-9-033-1	WAND - 2PC. 1 1/2"	1

# RECOVERY TANK ASSEMBLY

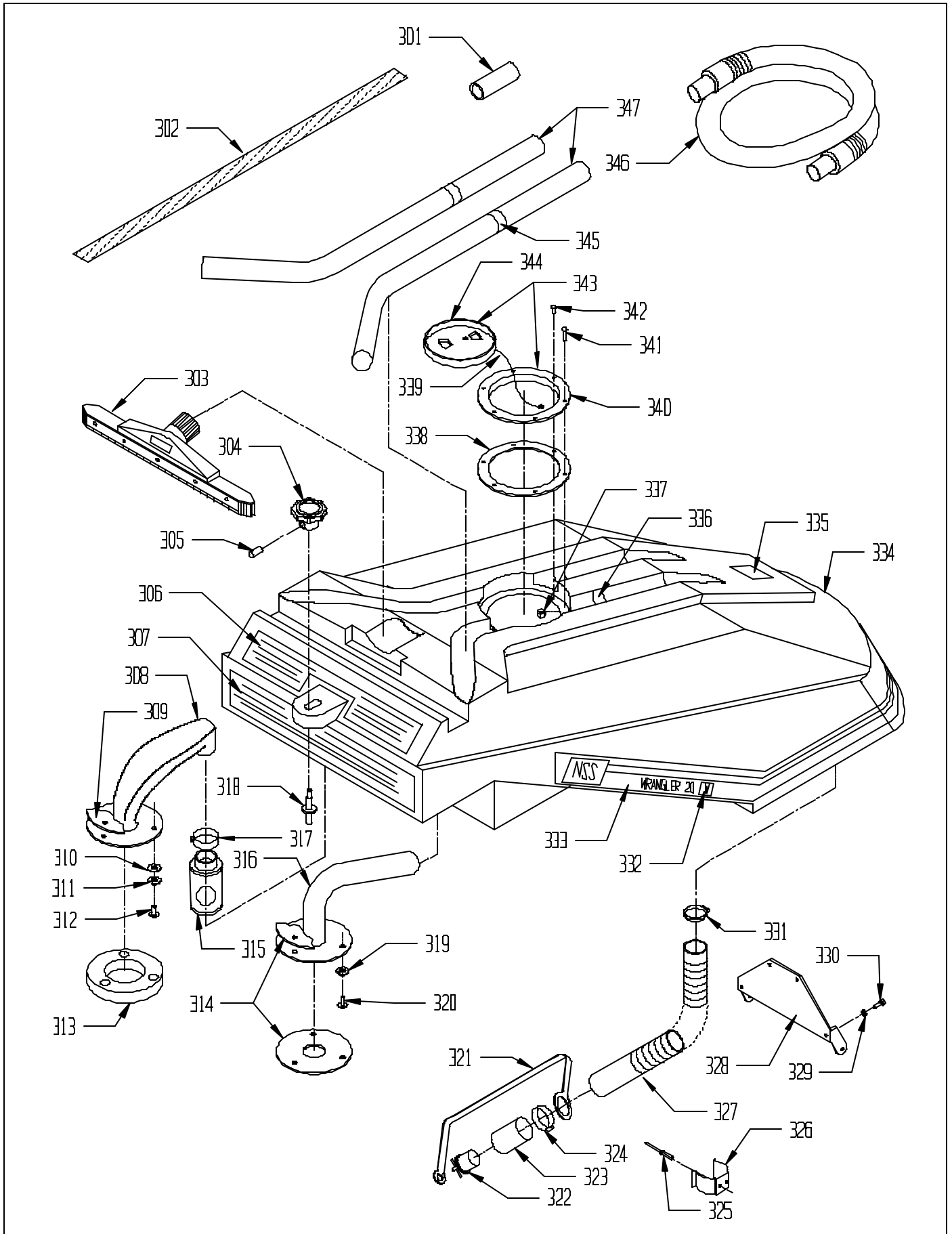

## CONTROL PANEL ASSEMBLY

ITEM	PART NO.	DESCRIPTION	QTY
401	23-9-573-1	CONTROL LABEL	1
402	23-9-138-1	PLUG STRAP	1
403	70-9-006-6	HOLE PLUG	1
404	91-2-027-0	8-24 X 7/8 ROUND HEAD PHILLIPS MACHINE SCREW	1
405	06-9-314-1	RUBBER SWITCH BOOT	2
406	06-9-185-1	LOCK WASHER	2
407	10-9-987-1	FLAT WASHER FOR M-1, STAINLESS	2
408	23-9-571-1	CONTROL PANEL	1
409	91-2-247-0	9/16 I.D. X 1 3/8 O.D. X .086/.132 THICK WROUGHT WASHER (1/2)	2
410	23-9-250-1	1/2-13 X 1 1/4 BUTTON HEAD SOCKET SCREW	2
411	23-9-197-3	BALANCE WEIGHT	2
412	52-9-379-1	CORD - 75 FEET, 14-3 ST, 120 VOLT	1
	02-9-967-1	SHUKO CORD 75 FEET, 16-3, 240 VOLT	1
	55-9-208-1	FEMALE TWIST LOCK 120 VOLT / 240 VOLT	1
413	02-9-966-1	STRAIN RELIEF CORD CLAMP	1
414	23-9-240-2	STRAIN RELIEF PLATE, TAPPED	1
415	23-9-241-3	STRAIN RELIEF PLATE, CLEARANCE	1
416	50-9-167-1	STRAIN RELIEF, 120 VOLT	1
	02-9-953-1	STRAIN RELIEF, 240 VOLT	1
417	91-2-069-0	10-32 HEX NUT WITH STAR LOCK WASHER	2
418	91-2-069-0	10-32 HEX NUT WITH STAR LOCK WASHER	1
419	52-9-334-1	RECTIFIER	1
420	23-9-242-1	STUB CORD, W/MALE TWIST LOCK 120 VOLT	1
	23-9-244-9	STUB CORD, W/MALE TWIST LOCK 240 VOLT	1
	55-9-206-1	MALE TWIST LOCK 120 VOLT / 240 VOLT	1
421	23-9-539-3	COVER PANEL	1
422	91-2-037-0	7/32 I.D. X 1/2 O.D. X .032/.065 THICK SAE FLAT WASHER (#10)	2
423	91-2-032-0	#10 SPLIT LOCK WASHER	2
424	91-2-072-0	10-32 X 3/8 ROUND HEAD PHILLIPS MACHINE SCREW	2
425	23-9-605-1	LABEL, VAC MOTOR ACCESS	1
426	91-2-037-0	7/32 I.D. X 1/2 O.D. X .032/.065 THICK SAE FLAT WASHER (#10)	3
427	91-2-043-0	10-24 X 3/4 ROUND HEAD PHILLIPS MACHINE SCREW	3
428	23-9-153-1	FILTER	1
429	04-9-355-1	"U" SHAPED GASKET	1
430	23-9-549-3	COVER BOX	1
431	23-9-543-1	BRUSH LABEL	1
432	23-9-592-1	SQUEEGEE LIFT HANDLE	1
433	13-9-079-3	SQUEEGEE LIFT BRACKET	1
434	91-2-099-0	1/4-20 X 3/8 TRUSS HEAD PHILLIPS MACHINE SCREW	2
435	13-9-094-1	5/16 E RING	2
436	24-9-530-1	Y SQUEEGEE LIFT CABLE 25" / 63.5cm	1
437	91-2-038-0	10-24 X 3/8 ROUND HEAD PHILLIPS MACHINE SCREW	1
438	91-2-032-0	#10 SPLIT LOCK WASHER	1
439	91-2-037-0	7/32 I.D. X 1/2 O.D. X .032/.065 THICK SAE FLAT WASHER (#10)	1
440	23-9-137-1	KNURLED KNOB	4
441	91-2-069-0	10-32 HEX NUT WITH STAR LOCK WASHER	4
442	91-2-037-0	7/32 I.D. X 1/2 O.D. X .032/.065 THICK SAE FLAT WASHER (#10)	4
443	23-9-223-1	WIRING DIAGRAM DECAL	1
444	23-9-249-1	10-32 X 1 3/4 SET SCREW	4
445	91-2-164-0	5/16-18 X 3/4 HEX BOLT	3
446	91-2-141-0	5/16 EXTERNAL STAR LOCK WASHER	4
447	91-2-139-0	11/32 I.D. X 11/16 O.D. X .051/.080 THICK SAE FLAT WASHER (5/16)	4
448	06-9-076-1	PLUG BUTTON	2
449	91-2-168-0	5/16-18 X 1 HEX BOLT	1
450	23-9-291-1	HOSE / WIRE TIE DOWN	1
451	91-2-091-0	1/4-20 HEX NUT WITH STAR LOCK WASHER	4
452	91-2-093-0	9/32 I.D. X 5/8 O.D. X .051/.080 THICK SAE FLAT WASHER (1/4)	4
453	26-9-098-1	LIFT HANDLE GRIP	1
454	91-2-230-0	3/8-16 X 1 1/4 HEX BOLT	1
455	91-2-210-0	3/8 SPLIT LOCK WASHER	1
456	91-2-198-0	7/16 I.D. X 1 O.D. X .075/.080 THICK SAE FLAT WASHER (3/8)	3
457	23-9-537-1	LOCK DOWN LIFT ROD	1
458	91-2-200-0	3/8-16 HEX NUT	1
459	26-9-182-1	HOUSING - SPRING, BRUSH	1
460	91-2-214-0	3/8-16 HEX NUT WITH NY-LOK INSERT	1
461	26-9-184-1	SPRING, BRUSH PRESSURE	1
462	26-9-183-1	HOUSING - SPRING RETAINER	1

# CONTROL PANEL ASSEMBLY

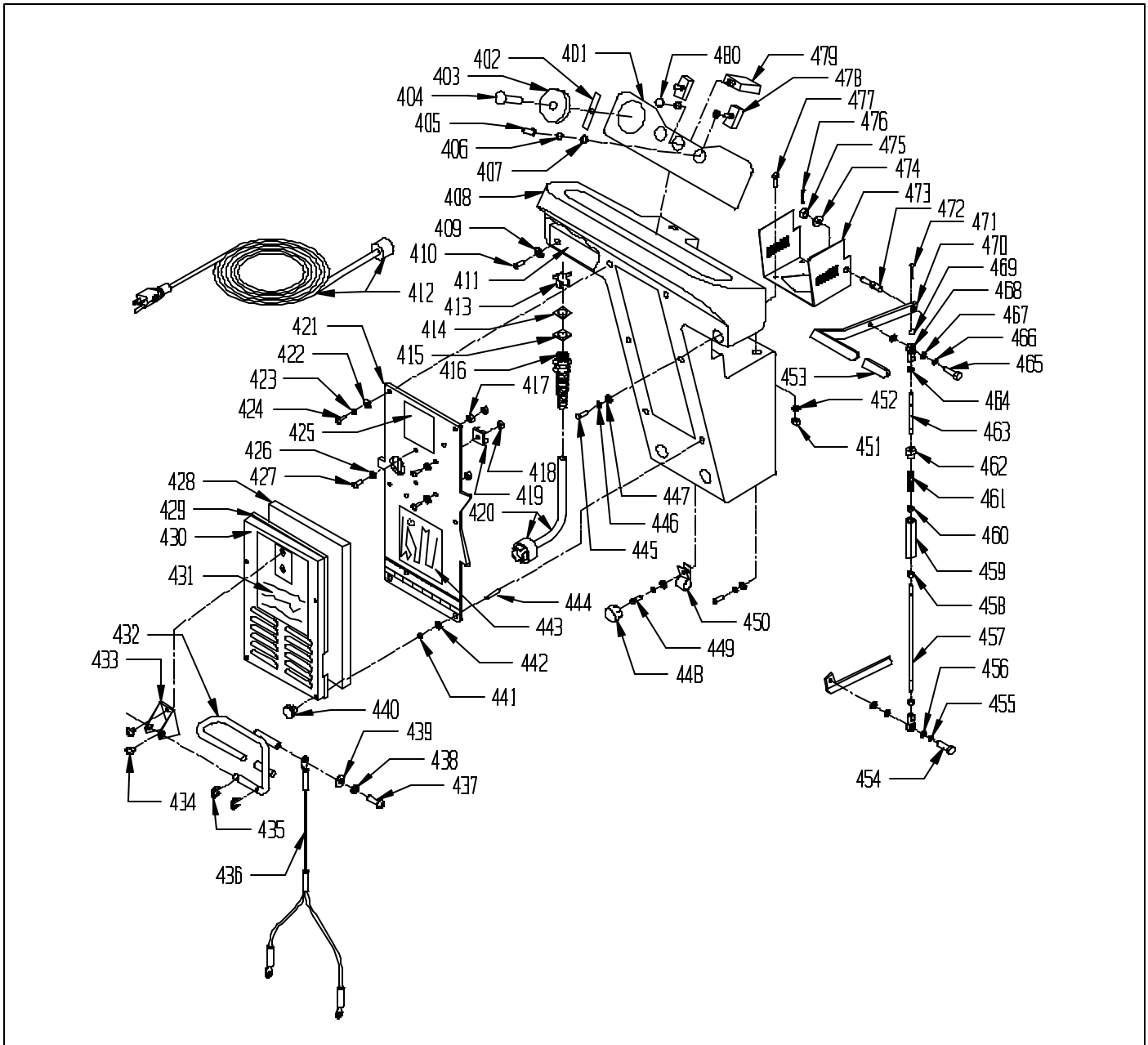

ITEM	PART NO.	DESCRIPTION	QTY
463	26-9-181-1	SHORT LIFT ROD, BRUSH	1
464	91-2-201-0	3/8-24 HEX NUT	2
465	91-2-198-0	7/16 I.D. X 1 O.D. X .075/.080 THICK SAE FLAT WASHER (3/8)	2
466	91-2-226-0	3/8-16 X 1 HEX BOLT	1
467	91-2-210-0	3/8 SPLIT LOCK WASHER	1
468	44-9-053-1	3/8 ROD END	2
469	23-9-256-1	CIRCLE COTTER - #CC-7	1
470	26-9-137-3	BRUSH LIFT HANDLE	1
471	23-9-195-1	PIN	1
472	24-9-060-1	PIVOT STUD	1
473	23-9-556-3	BRACKET, MOUNT LIFT ARM	1
474	91-2-245-0	17/32 I.D. X 1 1/16 O.D. X .074/.121 THICK SAE FLAT WASHER (1/2)	1
475	23-9-271-1	1/2-13 SLOTTED HEX NUT	1
476	52-9-652-1	HUMPED COTTER PIN	1
477	91-2-125-0	1/4-20 X 3/4 HEX BOLT WITH NYLON PATCH	4
478	07-9-204-1	SWITCH, TOGGLE VAC	2
479	23-9-220-1	CIRCUIT BREAKER, 115 VOLT 10 AMP	1
	23-9-270-1	CIRCUIT BREAKER, 240 VOLT 5 AMP	1
480	48-9-247-1	CIRCUIT BREAKER BUTTON SEAL	1

## **BRUSH HEAD ASSEMBLY**

<u>ITEM</u>	<u>PART NO.</u>	<u>DESCRIPTION</u>	<u>QTY</u>
501	23-9-303-1	MOTOR HOUSING (IMPERIAL)	1
502	54-9-017-1	1/4 MALE SPADE TERMINAL FULLY INSULATED	2
503	23-9-301-1	GEAR MOTOR IMPERIAL 3/4 HP 120 VOLT AC	1
	23-9-301-9	IMPERIAL MOTOR W/ COVER & SKIRT	1
	23-9-302-1	GEAR MOTOR IMPERIAL 3/4 HP 240 VOLT AC	1
	23-9-302-9	IMPERIAL MOTOR W/ COVER & SKIRT	1
504	27-9-268-1	1/4" SQUARE X 1" LONG KEY - STEEL	1
505	91-2-024-0	8-32 X 1/2 ROUND HEAD PHILLIPS MACHINE SCREW	2
506	91-2-018-0	#8 INTERNAL STAR LOCK WASHER	2
507	23-9-113-6	WATER FEED TUBE	1
508	23-9-248-1	HOSE CLAMP, 7/32" TO 5/8" DIAMETER	1
509	23-9-598-7	VINYL HOSE, 3/8 I.D. X 23" LONG	1
510	23-9-304-3	SKIRT (IMPERIAL)	1
511	91-2-152-0	5/16 SPLIT LOCK WASHER	8
512	91-2-164-0	5/16-18 X 3/4 HEX BOLT	8
513	91-2-019-0	8-32 HEX NUT WITH STAR LOCK WASHER	2
514	23-9-306-1	SPACER FOR IMPERIAL MOTOR	1
515	23-9-305-2	CLUTCH CASTING	1
516	52-9-354-1	13/32 I.D. X 1 1/4 O.D. X .12 THICK FLAT WASHER (11 GAGE).	1
517	91-2-152-0	5/16 SPLIT LOCK WASHER	1
518	23-9-112-1	BUMPER GUARD	1
519	23-9-170-2	SKIRT BAND	1
520	91-2-045-0	10-24 X 1 ROUND HEAD PHILLIPS MACHINE SCREW	1
521	26-9-260-1	PAD DRIVER	1
522	52-9-769-1	PAD HOLDER BASE (YELLOW)	1
523	44-9-548-1	LOCK RING DEEP (YELLOW)	1
	59-9-072-1	SPRING CLIP PAD HOLDER SET (WHITE)	1
524	91-2-079-0	10 X 5/8 PAN HEAD PHILLIPS SHEET METAL SCREW	3
525	28-9-010-1	CLUTCH PLATE, PLASTIC 5" DIAMETER, 6 HOLES	1
	28-9-097-1	6 HOLE PLASTIC CLUTCH PLATE - BROWN, TRU FIT	1
526	—————10	X 1 FLAT HEAD SCREW	6
527	91-2-035-0	10-24 HEX NUT WITH NY-LOK INSERT	1
528	91-2-164-0	5/16-18 X 3/4 HEX BOLT	1
529	91-2-152-0	5/16 SPLIT LOCK WASHER	1
530	91-2-156-0	5/16-18 X 1/2 HEX BOLT	1
531	91-2-141-0	5/16 EXTERNAL STAR LOCK WASHER	1
532	91-2-222-0	3/8-16 X 3/4 HEX BOLT	4
533	91-2-210-0	3/8 SPLIT LOCK WASHER	4
534	23-9-227-6	BUMPER WHEEL AXLE	1
535	27-9-028-1	3" BUMPER WHEEL	1
536	91-2-139-0	11/32 I.D. X 11/16 O.D. X .051/.080 THICK SAE FLAT WASHER (5/16)	1
537	91-2-141-0	5/16 EXTERNAL STAR LOCK WASHER	1
538	91-2-156-0	5/16-18 X 1/2 HEX BOLT	1
539	23-9-309-1	3/8 I.D. X 1 O.D. X .031 THICK FLAT WASHER (SHIM)	2
540	23-9-184-1	MOTOR STRIPE LABEL	1

# BRUSH HEAD ASSEMBLY

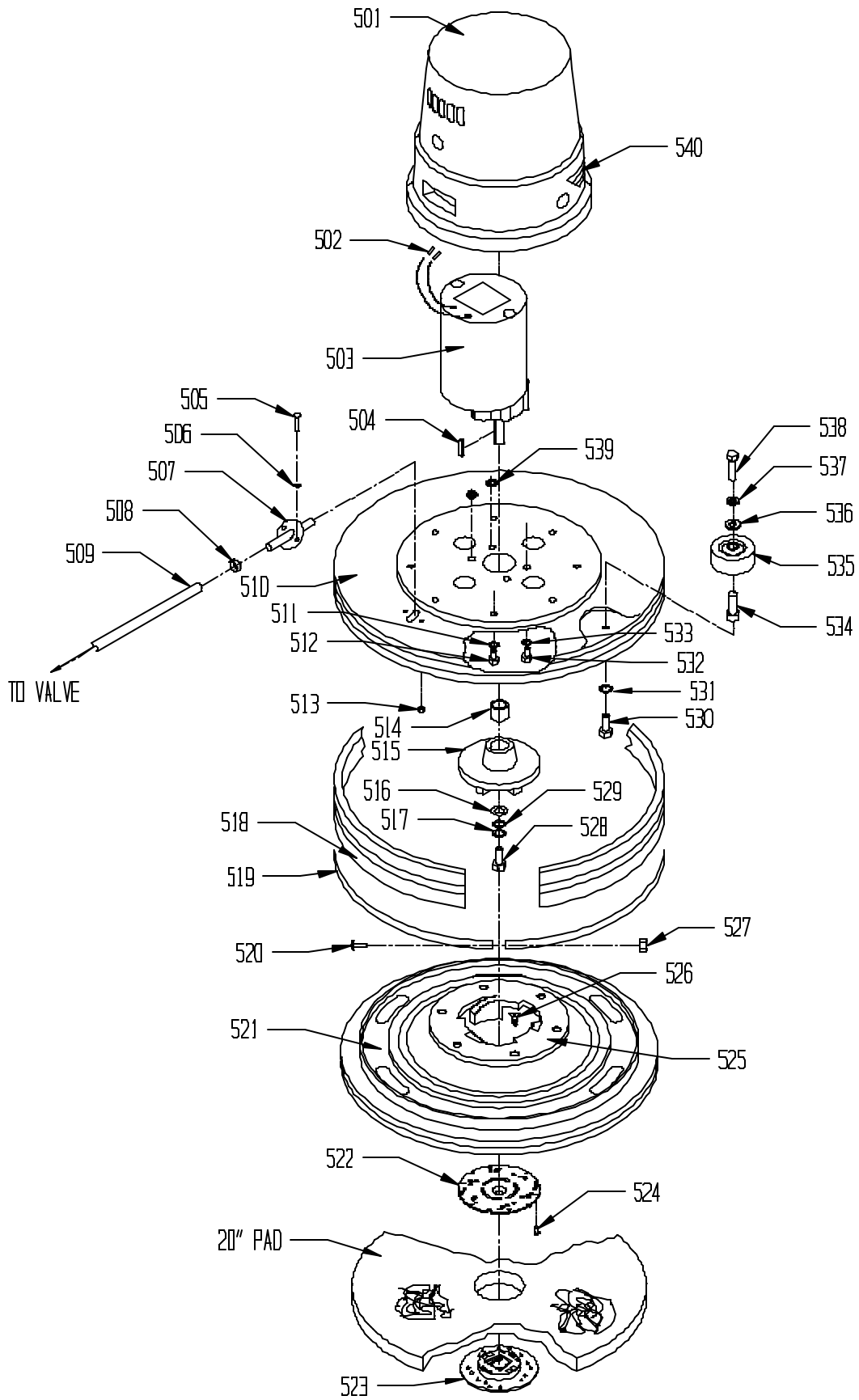

## SQUEEGEE ASSEMBLY

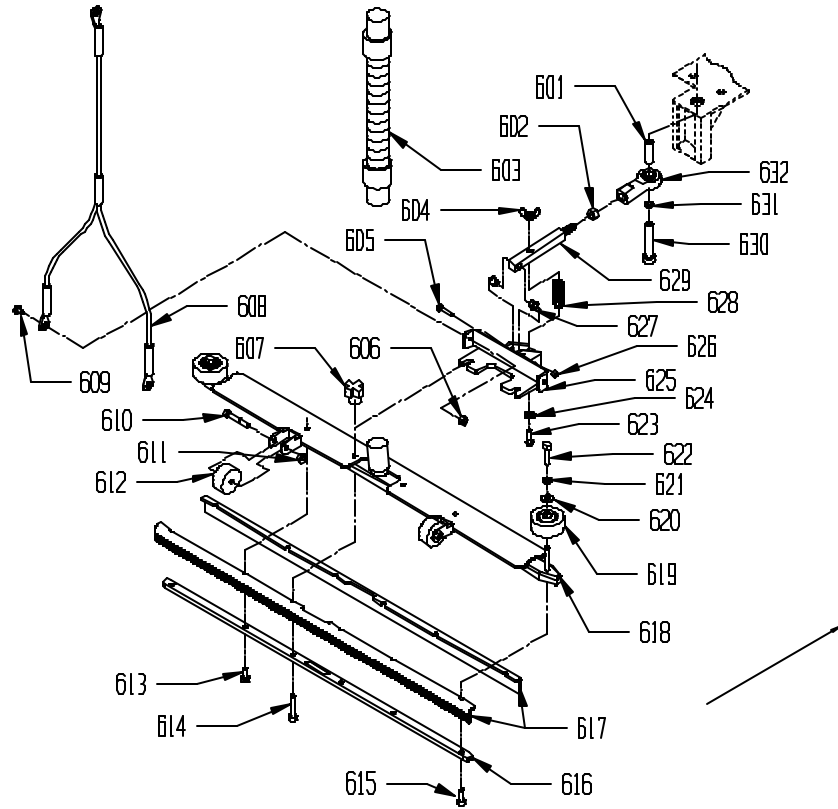

ITEM	PART NO.	DESCRIPTION	QTY
601	24-9-059-1	SPACER, SQUEEGEE PIVOT	1
602	91-2-267-0	1/2-20 HEX JAM NUT	1
603	26-9-059-1	SQUEEGEE VAC HOSE W/CUFFS	1
604	91-2-144-0	5/16-18 WING NUT	1
605	91-2-234-0	3/8-16 X 2 HEX BOLT	1
606	91-2-090-0	1/4-20 HEX NUT WITH NY-LOK INSERT	2
607	27-9-100-2	SQUEEGEE KNOB, MACHINED	2
608	24-9-530-1	Y SQUEEGEE LIFT CABLE 25"/63.5cm	1
609	91-2-101-0	1/4-20 X 3/4 TRUSS HEAD PHILLIPS MACHINE SCREW	2
610	91-2-176-0	5/16-18 X 1 3/4 HEX BOLT	2
611	91-2-145-0	5/16-18 HEX NUT WITH NY-LOK INSERT	2
612	30-9-674-1	WHEEL, BUMPER - SMALL GRAY	2
613	91-2-188-0	5/16-18 X 3/4 SOCKET HEAD CAP SCREW	2
614	91-2-192-0	5/16-18 X 1 1/2 SOCKET HEAD CAP SCREW	2
615	91-2-188-0	5/16-18 X 3/4 SOCKET HEAD CAP SCREW	2
616	26-9-253-3	INNER CHANNEL, SQUEEGEE - NARROW MOUNT	1
617	27-9-106-1	32" REPLACEMENT SQUEEGEE BLADES, SET OF 2	1
618	26-9-252-3	NARROW MOUNT SQUEEGEE HOUSING	1
	26-9-253-9	NARROW MOUNT SQUEEGEE ASSEMBLY (INCL. ITEMS 610-622)	1
619	27-9-028-1	3" BUMPER WHEEL	2
620	91-2-139-0	11/32 I.D. X 11/16 O.D. X .051/.080 THICK SAE FLAT WASHER (5/16)	2
621	91-2-141-0	5/16 EXTERNAL STAR LOCK WASHER	2
622	91-2-156-0	5/16-18 X 1/2 HEX BOLT	2
623	91-2-213-0	5/16-18 X 2 1/4 HEX BOLT	1
624	91-2-152-0	5/16 SPLIT LOCK WASHER	1
625	13-9-017-1	SQUEEGEE BRACKET	1
626	91-2-214-0	3/8-16 HEX NUT WITH NY-LOK INSERT	1
627	13-9-117-1	BUSHING, SQUEEGEE SHAFT	2
628	36-9-558-1	HEIGHT ADJUSTING SPRING	1
629	13-9-015-6	3/8" FLANGE NYLINER	1
630	91-2-266-0	1/2-13 X 3 HEX BOLT WITH NYLON PATCH	1
631	10-9-098-1	SPACER	1
632	23-9-194-1	BALL JOINT	1

## CURVED SQUEEGEE ASSEMBLY 24-9-249-9

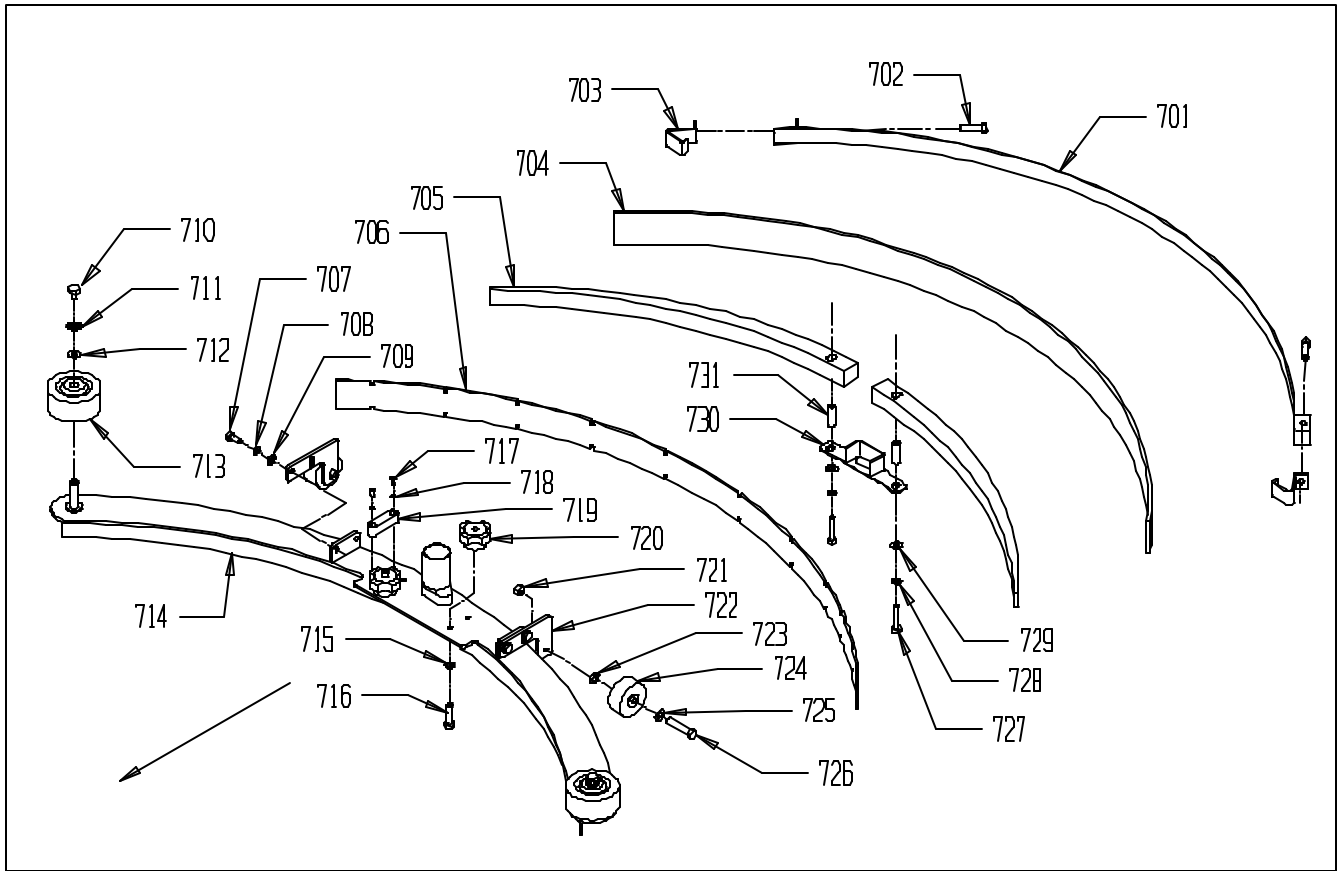

ITEM	PART NO.	DESCRIPTION	QTY
701	24-9-255-1	REAR SECURING STRAP	1
702	91-2-172-0	5/16-18 X 1 1/4 FULL THREADED HEX HEAD BOLT	2
703	24-9-256-1	HOOKED END	2
704	24-9-253-1	REAR BLADE	1
705	24-9-251-1	CENTER WEDGE	2
706	24-9-252-1	FRONT BLADE	1
707	91-2-121-0	1/4-20 X 5/8 HEX BOLT	4
708	91-2-088-0	1/4 SPLIT LOCK WASHER	4
709	91-2-093-0	9/32 I.D. X 5/8 O.D. X .051/.080 THICK SAE FLAT WASHER (1/4)	4
710	91-2-156-0	5/16-18 X 1/2 HEX BOLT	2
711	91-2-141-0	5/16 EXTERNAL STAR LOCK WASHER	2
712	91-2-139-0	11/32 I.D. X 11/16 O.D. X .051/.080 THICK SAE FLAT WASHER (5/16)	2
713	27-9-028-1	BUMPER WHEEL	2
714	24-9-250-3	MAIN HOUSING	1
	24-9-249-9	CURVED SQUEEGEE ASSEMBLY	1
715	91-2-152-0	5/16 SPLIT LOCK WASHER	2
716	91-2-172-0	5/16-18 X 1 1/4 FULL THREADED HEX HEAD BOLT	2
717	91-2-007-0	6-32 X 3/8 ROUND HEAD PHILLIPS MACHINE SCREW	2
718	91-2-003-0	#6 SPLIT LOCK WASHER	2
719	24-9-258-1	SQUEEGEE LEVEL	1
720	27-9-100-2	SQUEEGEE KNOB	2
721	91-2-145-0	5/16-18 HEX NUT WITH NY-LOK INSERT	2
722	24-9-257-1	DOLLY WHEEL MOUNTING BRACKET	2
723	91-2-139-0	11/32 I.D. X 11/16 O.D. X .051/.080 THICK SAE FLAT WASHER (5/16)	2
724	30-9-674-1	ROLLER WHEEL	2
725	91-2-139-0	11/32 I.D. X 11/16 O.D. X .051/.080 THICK SAE FLAT WASHER (5/16)	2
726	91-2-176-0	5/16-18 X 1 3/4 HEX BOLT	2
727	91-2-128-0	1/4-20 X 1 1/2 HEX BOLT	2
728	91-2-088-0	1/4 SPLIT LOCK WASHER	2
729	91-2-093-0	9/32 I.D. X 5/8 O.D. X .051/.080 THICK SAE FLAT WASHER (1/4)	2
730	24-9-254-1	CENTER HOLD DOWN	1
731	24-9-259-1	CENTER HOLD DOWN SPACER	2

## BRUSH GEAR MOTOR

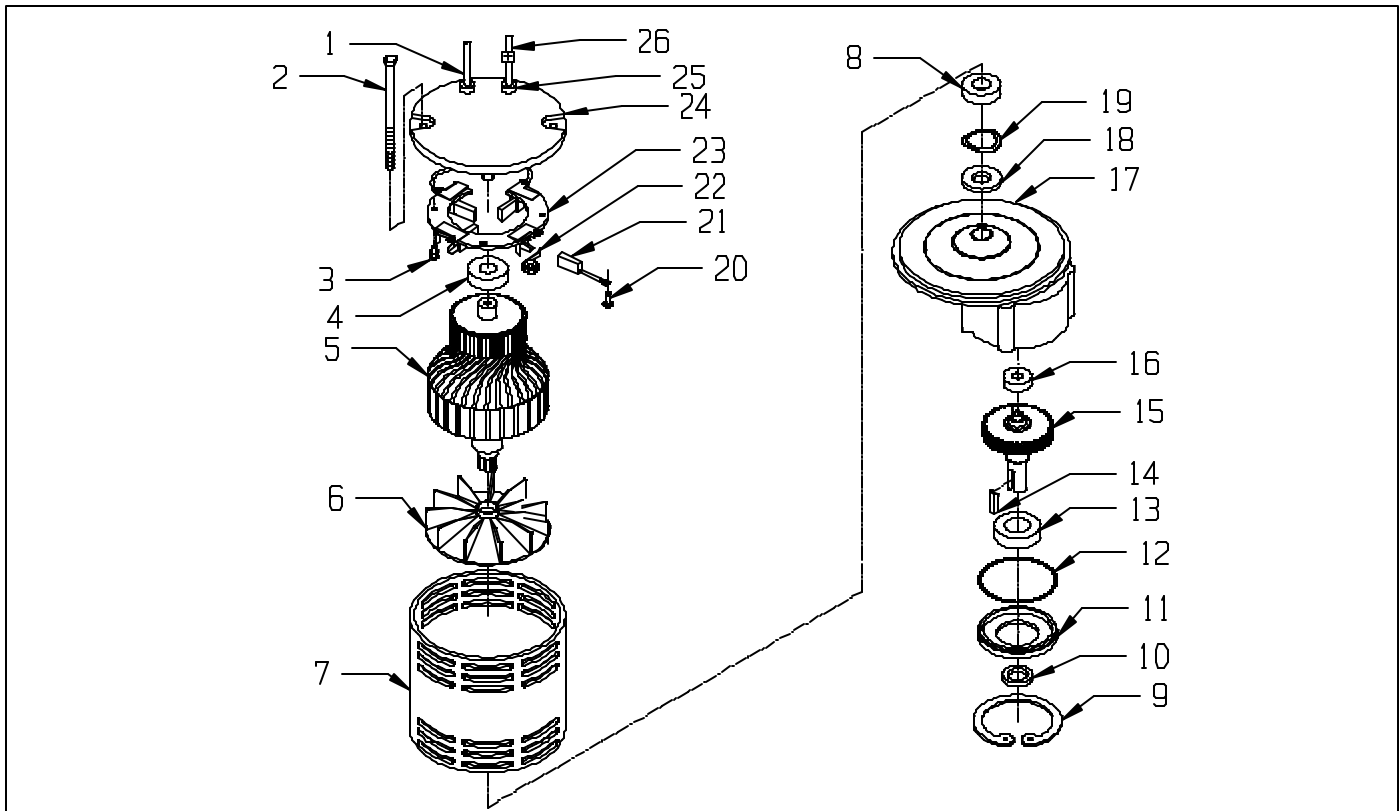

ITEM	PART NO.	DESCRIPTION	QTY.
	23-9-300-1	COMPLETE MOTOR ASSEMBLY - 120 VOLT	1
	23-9-302-1	COMPLETE MOTOR ASSEMBLY - 24- VOLT	1
1	23-9-327-1	NEGATIVE LEAD	1
2	33-9-120-1	THRU BOLT 1/4-20 X 7 3/4	2
3	—————	10-24 X 1/2 SELF TAP ROUND HEAD SLOTTED SCREW	2
4	50-9-204-1	TOP END BEARING	1
5	23-9-316-1	ARMATURE ASSEMBLY, INCLUDES VENT FAN AND BEARINGS - 120 VOLT	1
	23-9-321-1	ARMATURE ASSEMBLY, INCLUDES VENT FAN AND BEARINGS - 240 VOLT	1
6	33-9-119-1	ARMATURE VENT FAN	1
7	23-9-315-1	STATOR FRAME ASSEMBLY WITH MAGNETS	1
8	33-9-105-1	BOTTOM END BEARING	1
9	33-9-117-1	SNAP RING	1
10	33-9-116-1	OIL SEAL, SMALL	1
11	33-9-115-1	END CAP	1
12	33-9-114-1	"O" RING	1
13	33-9-113-1	BOTTOM BEARING, LARGE	1
14	27-9-268-1	MOTOR KEY, 1/4 X 1/4 X 1	1
15	33-9-112-1	GEAR SHAFT	1
16	33-9-111-1	TOP BEARING, SMALL	1
17	33-9-110-1	GEAR BOX - HOUSING ONLY	1
	33-9-118-1	GEAR BOX ASSEMBLY, (INCLUDES ITEMS 9 TO 18)	1
18	33-9-109-1	OIL SEAL, LARGE	1
19	27-9-759-1	HELICAL WASHER	1
20	—————	10-32 X 1/2 PAN HEAD SLOTTED SCREW, BRASS	4
21	23-9-319-1	CARBON BRUSH - 120 VOLT	4
	23-9-324-1	CARBON BRUSH - 240 VOLT	4
22	27-9-757-1	CARBON BRUSH SPRING	4
23	23-9-317-1	BRUSH BOARD ASSEMBLY, INCL. CARBON BRUSHES & SPRINGS - 120 VOLT	1
	23-9-322-1	BRUSH BOARD ASSEMBLY, INCL. CARBON BRUSHES & SPRINGS - 240 VOLT	1
24	33-9-100-1	TOP END BRACKET ONLY	1
	23-9-318-1	TOP END BRACKET WITH BRUSH BOARD ASSEMBLY - 120 VOLT	1
	23-9-323-1	TOP END BRACKET WITH BRUSH BOARD ASSEMBLY - 240 VOLT	1
25	23-9-320-1	STRAIN RELIEF	2
26	23-9-326-1	POSITIVE LEAD	1

# ELECTRICAL WIRING DIAGRAM

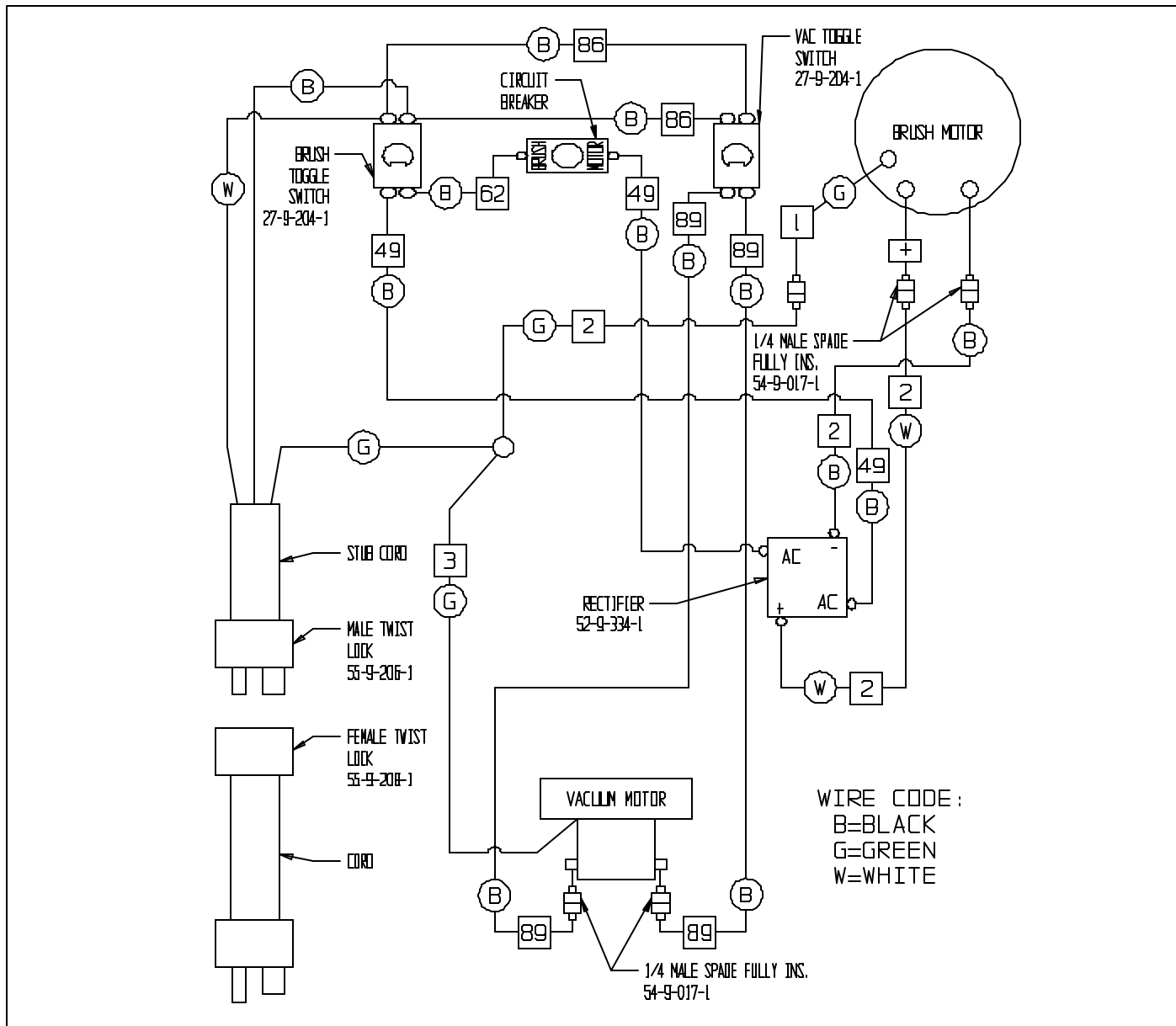

ITEM	PART NO.	DESCRIPTION	QTY
1	23-9-287-1	GROUND WIRE 115 VOLT / 240 VOLT	1
2	23-9-308-1	MOTOR CORD, 115 VOLT & 240 VOLT	1
3	32-9-069-1	GREEN WIRE GROUND TO MOTOR	1
49	27-9-216-1	WIRE ASSEMBLY, #14 X 12", 49	2
62	27-9-237-1	WIRE #14 X 6", #62	1
86	33-9-073-1	WIRE #18 X 10", #86	2
89	23-9-202-1	WIRE LEAD VACUUM - SWITCH	2
—	02-9-967-1	SHUKO CORD 75' 16-3 240 VOLT	1
—	23-9-107-1	VACUUM MOTOR 120 VOLT	1
—	23-9-109-1	VACUUM MOTOR 240 VOLT	1
—	23-9-220-1	CIRCUIT BREAKER, 115 VOLT 10 AMP	1
—	23-9-242-1	STUB CORD, WITH MALE TWIST LOCK 120 VOLT	1
—	23-9-244-9	STUB CORD, WITH MALE TWIST LOCK 240 VOLT	1
—	23-9-270-1	CIRCUIT BREAKER, 240 VOLT 5 AMP	1
—	23-9-301-1	GEAR MOTOR (IMPERIAL) 3/4 HP 120 VOLT	1
—	23-9-302-1	GEAR MOTOR (IMPERIAL) 3/4 HP 240 VOLT	1
—	23-9-379-1	CORD - 75 FEET, 14-3 ST, 120 VOLT	1
—	27-9-204-1	TOGGLE SWITCH - VAC	1
—	52-9-334-1	RECTIFIER, OHIO, VK - 447	1
—	54-9-017-1	1/4 MALE SPADE TERMINAL FULLY INSULATED	4
—	55-9-206-1	MALE TWIST LOCK 120/240 VOLT	1
—	55-9-208-1	FEMALE TWIST LOCK 120/240 VOLT	1

## **TROUBLE SHOOTING**

<b>PROBLEM</b>	<b>CAUSE</b>	<b>SOLUTION</b>
No Solution Flow	The solution valve is closed. Obstruction in the solution hose. Solution valve or linkage damaged. Solution tank is empty.	Open the solution valve. Remove the obstruction. Repair/replace the valve linkage. Fill the tank.
Solution Flow Does Not Stop	The solution valve is open Solution valve or linkage damage. Solution valve is dirty. Damaged seat and washer in valve. The valve stem is dirty.	Close the solution valve. Repair/replace the valve linkage. Clean the solution valve. Replace valve. Clean and lubricate valve stem.
Will Not Pick Up Any Water From Floor	Squeegee is up. Vac motor switch is "off". Recovery tank is full. Vacuum shut-off float is stuck. Obstruction/damage in the squeegee, squeegee hose or standpipe. Leaking cover gasket. Vac motor is not running	Lower squeegee. Turn vac motor switch "on". Empty tank. Open float valve/remove obstruction. Remove obstruction/repair damage.  Remove old gasket/replace. Have an authorized serviceman Repair.
Will Not Pick Up All Water From Floor	Squeegee blade is worn/damaged. Obstruction/damage in the squeegee, squeegee hose or standpipe. Squeegee pressure needs adjustment. Vacuum motor worn out.	Reverse/replace squeegee blade. Remove obstruction/repair damage.  Adjust pressure. Repair/replace vac motor.
Batteries Do Not Seem To Run Long Enough	Tops of batteries are dirty/wet Battery terminals are dirty/damaged.  Electrolyte level is too low. Batteries are not fully charged. Charger is damaged. Battery is defective.	Clean/dry charge batteries. Clean terminals and connectors, replace damaged cables. Charge. Add distilled water and charge. Charge batteries for 8 hours. Have an authorized serviceman repair. Check cell voltage while discharging.
Cleaning Is Not Even	Brush/pads are worn. Damage to brush assembly, casters, or solution valve. Motor is not running.	Replace. Have authorized serviceman repair.  Repair wiring, replace switch, replace carbon brushes. Reset circuit breaker button.

NOTE: If problems remain after taking the above steps, contact your local authorized service station for further evaluation and repair.



### **NSS ® Enterprises, Inc.**

3115 Frenchmens Road, Toledo, Ohio 43607  
 PHONE (419) 531-2121 FAX (419) 531-3761  
**NSS® Enterprises, Inc. European Distribution Centre**  
 Unit II, Pinfold Trading Estate \* 55 Nottingham Road  
 STAPLEFORD, NOTTINGHAM NG9 8AD ENGLAND U.K.  
 PHONE: (44) 0115 939 1568 \* FAX: (44) 0115 949 0615