



Electronic Service Manuals

This electronic document is provided as a service to our customers. We do not create the contents of the information contained in this document. Should you have detailed questions pertaining to the information contained in this document, you may contact Michco, or the manufacturer which provided the original information in this electronic deliverable. Michco's only part in this electronic deliverable was the electronic assembly process. By providing this manual on line we are not guaranteeing parts availability.

You may contact Michco through the following methods:

Phone (517) 484-9312 or (800) 331-3339

2011 N. High St. -- Lansing, Michigan -- 48906

Fax: (517) 484-9836

Email: CustServe@Michco.com

Web site: www.Michco.Com

Parts Web site: www.FloorMachineParts.Com

Order Parts on Line at:

www.FloorMachineParts.Com

Directly to Parts & Service:

By Email: **Shop@Michco.com**

By Fax: (517) 702-2041

By Voice: Use numbers above.

Serving the Cleaning Industry Since 1922

Notice: All copyrighted material remains property of original owners, all trademarks are property of respective owners. Manuals are subject to Manufacturer's reproduction limitations. Originals or reproductions were provided by manufacturers through a request. We make no warranty as to the correctness of information provided in this document and you assume all risk. By placing these manuals on line we are not declaring our corporation to be an manufacturer authorized dealer or provider, please check our web site for authorized manufacturers we represent.

USER AND MAINTENANCE MANUAL

E Ride 21



Warning:
read the instructions
before using the
machine

Original instructions

Minuteman International

14N845 U.S. Route 20,
Pingree Grove, IL 60140

Phone: (847) 264-5400

Fax: (847) 683-5207

Web: www.minutemanintl.com

TABLE OF CONTENTS

CHAPTER 1	INTRODUCTION	1-1
1.1	PURPOSE AND CONTENT OF THE MANUAL	1-1
1.2	TARGET	1-1
1.3	HOW TO KEEP THIS MANUAL	1-1
1.4	IDENTIFICATION DATA	1-2
1.5	OTHER REFERENCE MANUALS	1-2
1.6	SPARE PARTS AND MAINTENANCE	1-2
1.7	MODIFICATIONS AND IMPROVEMENTS	1-2
CHAPTER 2	SAFETY - ACCIDENT PREVENTION	2-1
2.1	SYMBOLS	2-1
2.2	GENERAL INSTRUCTIONS	2-1
2.3	UNPACKING	2-4
CHAPTER 3	MACHINE DESCRIPTION	3-1
3.1	SCRUBBER-DRYER OPERATION	3-1
3.2	AGREEMENTS	3-1
3.3	DESCRIPTION	3-2
3.4	TECHNICAL CHARACTERISTICS	3-7
3.5	ELECTRICAL DIAGRAM	3-9
3.6	ELECTRICAL PROTECTIONS	3-9
3.7	WASH-AND-DRY MACHINE EQUIPMENT	3-9
3.8	OPTIONAL ACCESSORIES	3-9
CHAPTER 4	USE	4-1
4.1	BATTERIES CONTROL / INSTALLATION ON A NEW WASH-AND-DRY MACHINE	4-1
4.2	BEFORE STARTING THE WASH-AND-DRY MACHINE	4-2
4.3	START UP AND STOPPING OF MACHINE	4-4
4.4	WASH-AND-DRY MACHINE IN OPERATION	4-6

4.5	AFTER MACHINE USE	4-6
4.6	EMPTYING THE TANKS	4-6
4.7	WASH-AND-DRY MACHINE PUSH/DRAWING MOVEMENT	4-8
4.8	LONG INACTIVITY OF THE WASH-AND-DRY MACHINE	4-8
4.9	FIRST PERIOD OF USE	4-8
CHAPTER 5	MAINTENANCE	5-1
5.1	SCHEDULED MAINTENANCE TABLE	5-1
5.2	SQUEEGEE CLEANING	5-2
5.3	CHECKING/SUBSTITUTION OF THE SQUEEGEE RUBBERS	5-3
5.4	HEIGHT ADJUSTMENT OF SQUEEGEE	5-4
5.5	BRUSH CLEANING	5-4
5.6	CYLINDRICAL BRUSH CLEANING	5-5
5.7	CLEANING THE DETERGENT SOLUTION (OR WATER FOR WASHING) FILTER	5-6
5.8	CLEANING THE NOZZLE AND FILTER DETERGENT SOLUTION SUPPLY TO THE DISC BRUSH	5-8
5.9	CLEANING THE NOZZLE AND FILTER DETERGENT SOLUTION SUPPLY TO THE CYLINDRICAL BRUSHES	5-9
5.10	CLEANING THE DETERGENT FEEDING SYSTEM (OPTIONAL)	5-9
5.11	BATTERY CHARGE	5-10
5.12	CHECKING/REPLACING THE FUSES	5-14
5.13	ASSEMBLY-DISASSEMBLY OF THE SUEEGEE	5-14
5.14	ASSEMBLY-DISASSEMBLY OF THE DISC BRUSH	5-16
5.15	CYLINDRICAL BRUSHES ASSEMBLY-DISASSEMBLY	5-17
CHAPTER 6	SAFETY FUNCTIONS	6-1
6.1	EMERGENCY STOP BUTTON	6-1
6.2	MICROSWITCH OF DRIVER'S SEAT	6-1
CHAPTER 7	TROUBLESHOOTING	7-1
CHAPTER 8	SCRAPPING	8-1

CHAPTER 1 INTRODUCTION

1.1 PURPOSE AND CONTENT OF THE MANUAL

The purpose of this manual is to provide the User with all necessary information to use the machine properly in a safe and autonomous way. It contains information about technical characteristics, operation, machine inactivity, maintenance, spare parts and safety conditions.

Before carrying out any procedure on the machine, the Operators and Technicians in charge of the maintenance must read this manual carefully. Contact Minuteman in case of doubts regarding the interpretation of the instructions and for any further information.

1.2 TARGET

This manual is intended for the Operator and the Technicians qualified for the machine maintenance. The operators must not carry out operations assigned to qualified technicians. Minuteman declines liability for any damage arising from not observing this prohibition.

1.3 HOW TO KEEP THIS MANUAL

The User and Maintenance Manual must be kept near the machine, inside an adequate case, far from liquids and other substances that can cause damage to it.

1.4 IDENTIFICATION DATA

The Machine Model and Serial Number are marked on the plate on the frame (battery side) and can be read from the outside (1, **Figure 1-1**).

This information is useful when requiring machine replacement parts. Use the following table to write down the machine identification data for any further reference.

MACHINE model:
MACHINE serial number:

1.5 OTHER REFERENCE MANUALS

Moreover, the following manuals are available:

- Service Manual (that can be consulted at any Minuteman Service Center)
- Spare Part List, supplied with the machine

1.6 SPARE PARTS AND MAINTENANCE

All necessary use, maintenance and repair procedures must be carried out by qualified personnel or by Minuteman SERVICE. Only original spare parts and accessories must be used.

Call Minuteman for service or to order spare parts and accessories, specifying the machine Model and Serial Number.

1.7 MODIFICATIONS AND IMPROVEMENTS

Minuteman constantly improves its products and reserves the right to make changes and improvements at its discretion without being obliged to apply such benefits to the machines previously sold.

Any modifications and/or accessory addition must be approved and performed by Minuteman.

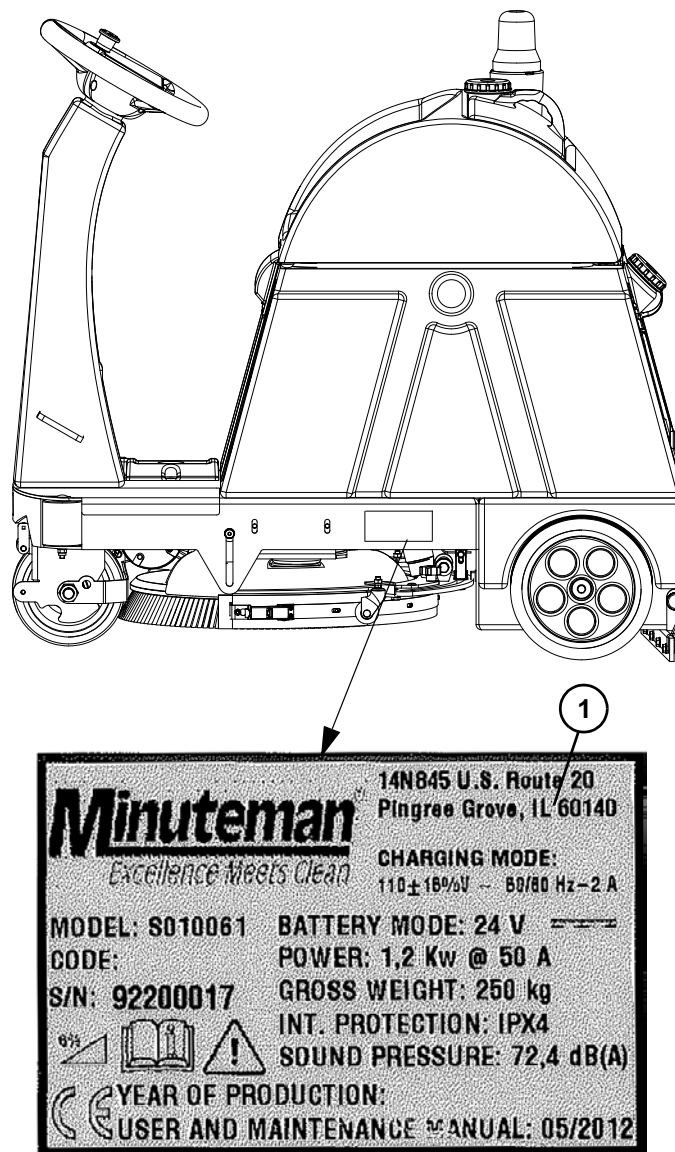

Figure 1-1

CHAPTER 2

SAFETY - ACCIDENT PREVENTION

The following symbols indicate potentially dangerous situations. Always read carefully this information and take the necessary precautions to protect people and objects. Cooperation between the Operator and the machine is critical. No accident prevention program is effective without the total cooperation of the person responsible for the machine operation. Most of the accidents that may occur in a factory, while working or transferring, are caused by the failure to comply with the simplest prudence rules. A careful and prudent user is the best guarantee against accidents and is the prerequisite to carry out the prevention program.

2.1 SYMBOLS



DANGER!

Indicates a dangerous situation (risk of death) for the User.



WARNING!

Indicates the risk for people of being injured and for objects of being damaged.



CAUTION!

Indicates a caution or a remark related to important or useful functions. Take care of the paragraphs marked by this symbol.



READING

Consult the instruction booklet before performing a determined operation.

2.2 GENERAL INSTRUCTIONS

Specific warnings and cautions to inform about potential damages to people and machine are shown below.



DANGER!

- Disconnect the battery by means of the appropriate connector before carrying out any maintenance or repair operation.
- This machine must be used by qualified and authorized personnel only. Children or infirm people cannot use this machine.
- Keep the battery far from sparks, flames and incandescent material. During the normal operation explosive gases are delivered.
- Do not wear jewelry when working near electrical components.
- Do not work under the lifted machine if it is not securely fixed.
- Do not operate the machine near dangerous, inflammable and/or explosive powders, liquids or vapours.
- Battery charging produces explosive hydrogen gas. Keep the tank assembly open during battery charging and perform the operation only in well-ventilated areas and far from open flames.



WARNING!

- Do not use the machine for purposes other than those listed in this manual. Use only accessories recommended by the manufacturer Minuteman.
- While using this machine take care not to cause injury or harm to yourself or others.
- Do not let the machine be used as a toy. Pay special attention when used near children.
- Always protect the machine against the sun, rain and bad weather, both under operation and in inactivity condition.
- Do not use the machine as a transport vehicle.
- Do not leave the machine unattended without being sure that the machine cannot move independently.
- Do not leave the machine unattended without removing the key from its housing.
- Do not use the machine in very dusty areas.
- Do not use the machine on surfaces with a gradient greater than 6%.
- Do not bump into shelves or scaffoldings, in particular where there is a risk of falling objects.
- Do not let any objects obstruct the air pathways. Do not use the machine if the pathways are blocked; always keep the air pathways free from dust, debris, and other materials which could reduce the air flow.
- To avoid the risk of electric shock, do not expose the machine to rain. Store the machine indoors.
- Do not remove or modify the plates affixed on the machine.
- The machine working temperature must be within 0°C - +40°C.
- Storage temperature must be within 0°C - +40°C.
- Humidity range should be within 30% and 95%.
- In case of machine malfunctions, review Chapter 5 (Maintenance) and 7 (Troubleshooting). Otherwise, request assistance from an authorized Minuteman service Dealer.
- Carefully read all maintenance/repair instructions before carrying out any maintenance/repair procedure.
- Do not tamper with the machine safety guards; For your safety, only follow the recommended maintenance instructions.
- Do not wash the machine with pressurized water, or with corrosive substances.
- Before using the battery charger, be sure that frequency and voltage values indicated in the specific Manual correspond to the system values.
- Do not recharge the batteries if the power cord or plug is damaged.
- Do not smoke during battery charging.
- To reduce the risk of fire, electric shock or injury, do not leave the machine charging for long periods of time. Unplug when connected to the machine from the wall outlet when not in use and before maintenance.

- Do not use the battery charger cable for hauling or transporting the machine. Do not let the power cord being crushed by a door, pull it over surfaces or sharp corners. Do not run with the machine over the power cord. Keep the cord away from hot surfaces.
- If the machine is not working properly, damaged, left outdoors or dropped into the water, ask for the intervention of a service center Minuteman.
- Take all necessary precautions to prevent hair, jewels and loose dresses from being caught by the machine moving and suction parts.
- If parts must be replaced, require ORIGINAL spare parts from a Dealer or Authorized Retailer.
- To ensure the machine proper operation and safety conditions, the authorized personnel or the Service Center must carry out the Scheduled Maintenance detailed in the related chapter of this Manual.
- If the machine is used according to the instructions, the vibrations do not cause dangerous situations. The machine vibration level is under 2.5 m/s².
- This machine cannot be used on roads or public streets.
- Pay attention to the machine transfers when temperature is under freezing point. The water in the recovery tank or in the pipes could freeze and damage the machine.
- Use the brushes and the disks supplied with the machine and those specified in the Instruction Manuals. Using other brushes or disks could reduce safety.
- If lead-acid batteries (WET) are installed in the machine, do not tilt the machine over 30 ° to the horizontal plane, to avoid the highly corrosive liquid escapes from the battery. When you need to tilt the machine for maintenance, remove the battery beforehand.
- The machine must be not abandoned, at the end of its useful life, because of the presence of toxic-harmful materials (battery acid, oil, etc.), which are subject to standards that require disposal in special centers (see chapter "Scrapping").

2.3 UNPACKING

To unpack the Machine carefully follow the instructions on the packing.

When the machine is delivered, check that the packing and the machine were not damaged during transportation. If the damage is evident, keep the packing and have it checked by the Parcel Service that delivered it. Call the Parcel Service immediately to fill in a request for a compensation for damages.

Please check that the following items have been supplied with the machine:

1. Technical documents:
 - Scrubber-dryer Use and Maintenance Manual
 - Spare Part List
2.

CHAPTER 3 MACHINE DESCRIPTION

3.1 SCRUBBER-DRYER OPERATION

The scrubber-dryer is used to clean (washing and drying) smooth and solid floor, in civil or industrial environment, under safe operation conditions by a qualified Operator. The scrubber-dryer cannot be used for fitted carpet and carpet cleaning.

3.2 AGREEMENTS

Forward, backward, front, rear, left or right are intended with reference to the operator's position with the operator's hands on the handlebar (12, **Figure 3-2**).

3.3 DESCRIPTION

Control panel and controls (See Figure 3-1)

1. Control panel and controls
2. Emergency stop button
3. Display, indicating:
 - 3a. "READY": wash-and-dry machine ready, or "SIT DOWN": sit on the seat
 - 3b. Total hours of work
 - 3c. Battery state of charge in %
 - 3d. Battery state of charge in graphic scale
4. Adjustment buttons (+ and -) of the detergent solution flow (or of the water for washing) (*)
5. Light indication of the detergent solution flow (or water for washing)
6. Adjustment buttons (+ and -) of the detergent percentage according to washing water (optional) (*)
7. Light indication of the detergent percentage (optional).
8. 30-second turbo button for activating the maximum detergent solution and detergent flow (or water for washing).
9. 30-second light indication.
10. Adjustment button of the maximum wash-and-dry machine speed (*)
11. Wash-and-dry machine instantaneous speed light indication
12. Button for activating the lowering and rotation of the disc brush (or cylindrical brushes)
13. Activated disc brush (or cylindrical brushes) light indication; the light indication blinks during the passage from de-activated to activated and vice versa
14. Button for activating the lowering of the squeegee and water recovery suction.
15. Activated squeegee and suction light indication; the light indication blinks during passing from de-activated to activated and vice versa
16. Simultaneous activation button for both the squeegee and suction and the disc brush (or cylindrical brushes).
17. Activated squeegee, suction and disc brush (or cylindrical brushes) light indication; the light indication blinks during passing from de-activated to activated and vice versa
18. Button for activating the reverse motion.
Speed is halved compared to the forward motion
An attention sound signal is activated for the activation time of the reverse motion
19. Reverse motion activated light indication
20. Button for activating the sound attention sound signal.
21. Button for releasing the disc brush.

(*): On starting the wash-and-dry machine through the key, these adjustments are set on previous values.

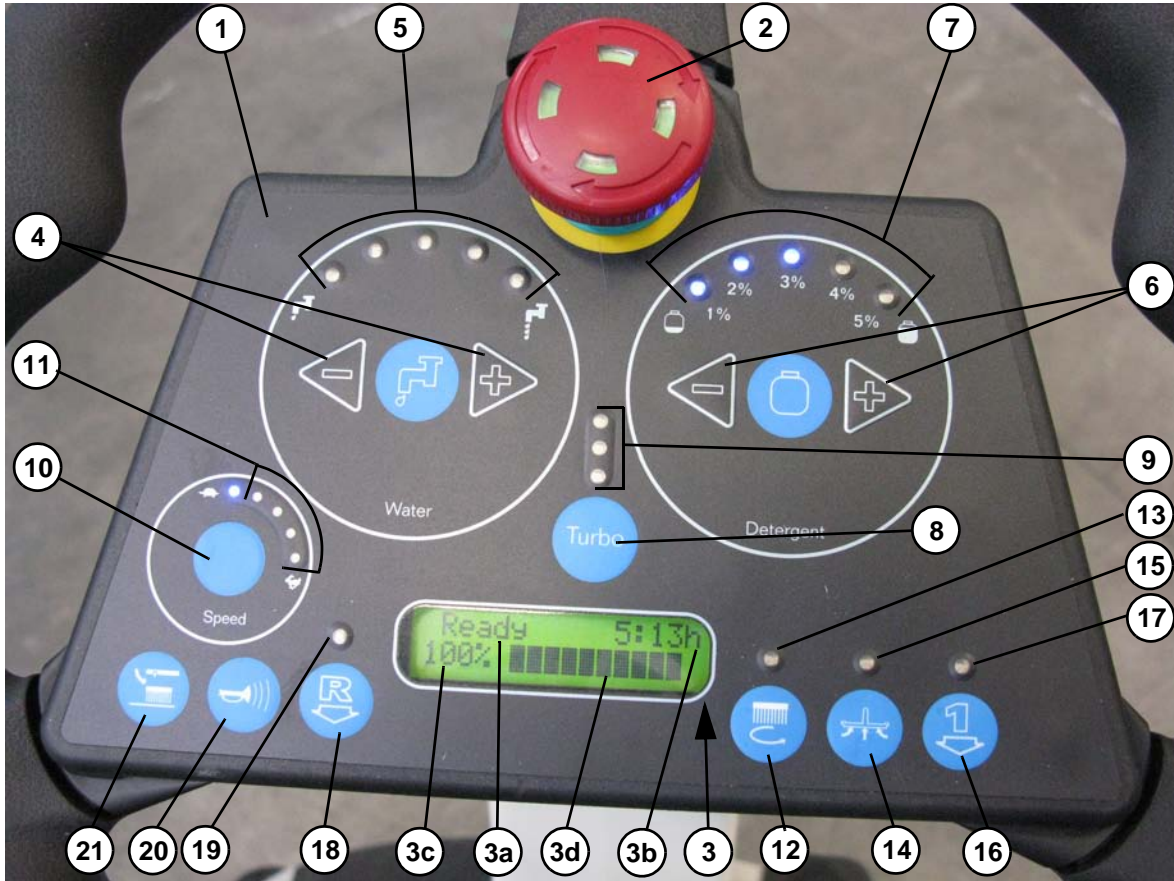

Figure 3-1

External views

(See Figure 3-2 and Figure 3-3)

1. Steering-wheel
2. Ignition key:
0: off
I: on
3. Pedal for starting motion and acceleration
4. Detergent solution (or water for washing) level indicator
5. Front drive and steering wheel
6. Rear wheels
7. Disc brush
8. Cylindrical brushes
9. Squeegee
- 10a. Detergent solution (or water for washing) tank
- 10b. Water recovery tank
11. Tank covers
12. Operator's seat
13. Detergent tank with handle (optional)
14. Detergent tank stopper
15. Detergent solution (or water for washing) tank stopper
16. Water recovery waste pipe
17. Detergent solution (or water for washing) waste pipe
18. Battery-holder case
19. Blinking light (optional)
20. Drinks-holding container (usable only if the blinking light is not installed)
21. Object-holding container (usable only if the detergent tank is not installed)
22. Protection panel of the electric-electronic compartment
23. Detergent solution (or water for washing) filter
24. Identification plate / technical data / CE marking

25. Tanks cover lifting handle
26. Heel cushion
27. Rear wheel cover
28. Rear wheel mudguard
29. Emergency and parking brake

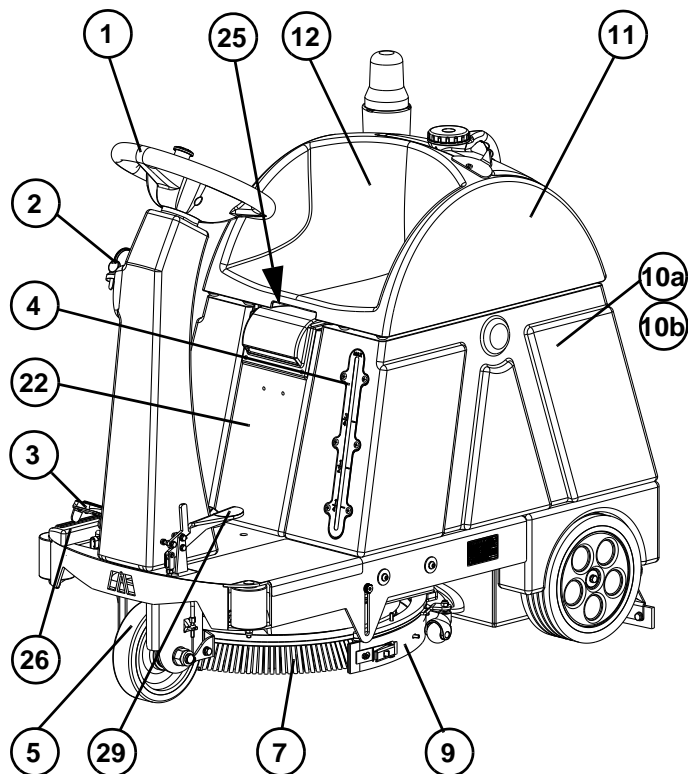

Figure 3-2

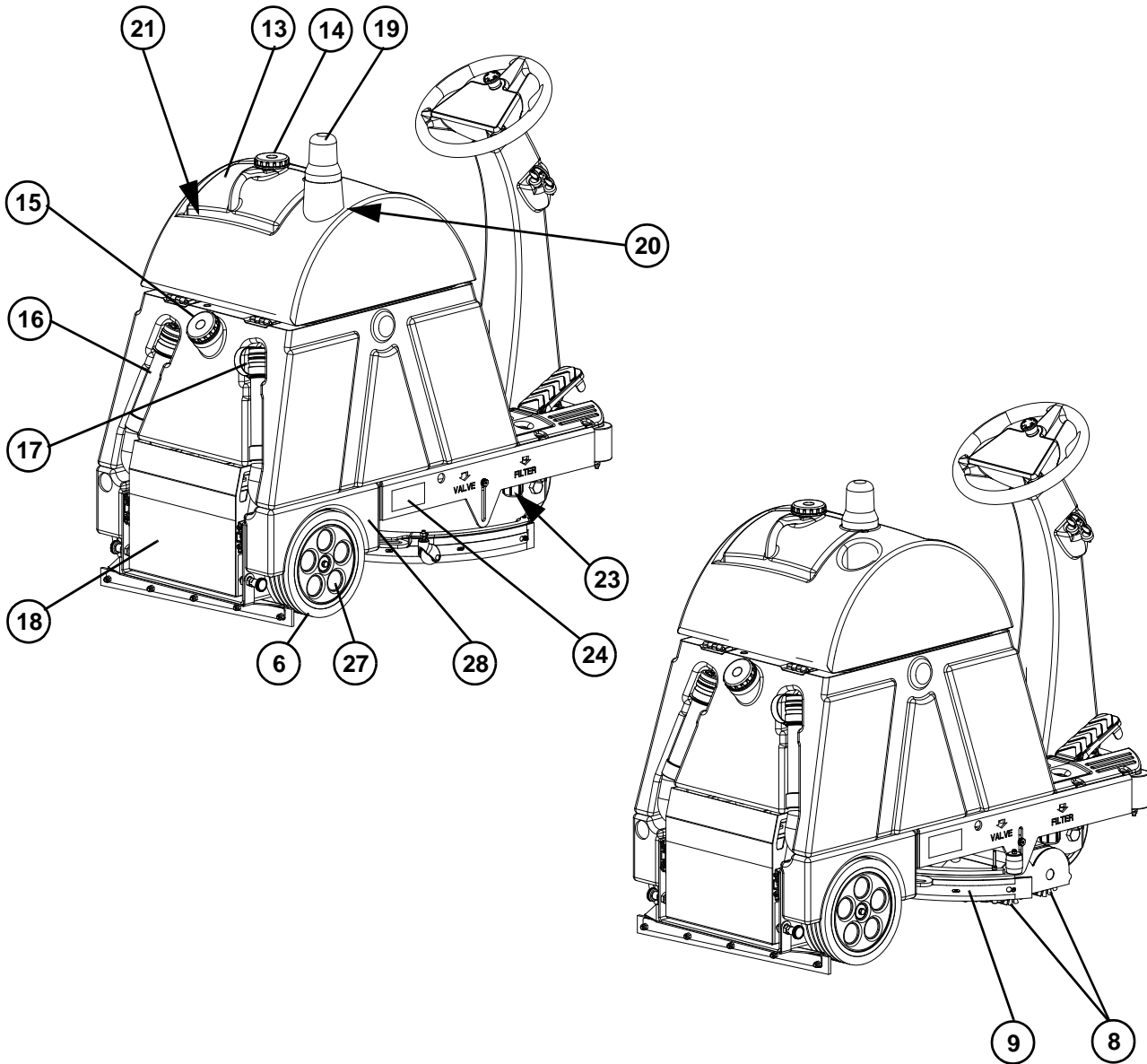

Figure 3-3

Internal parts view
(See Figure 3-4)

1. Tank covers (in uplifted position)
2. Handle for cover opening
3. Water recovery tank
4. Float for full water recovery tank
5. Batteries
6. Batteries connector
7. Battery charger connector of wash-and-dry machine for connection to the electric network (optional)

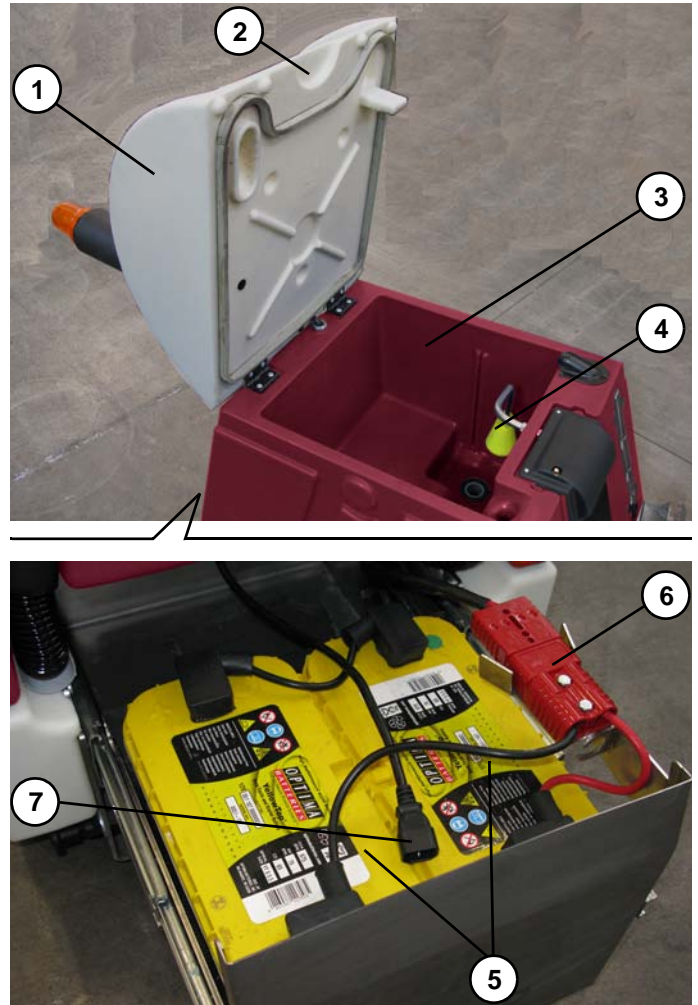

Figure 3-4

3.4 TECHNICAL CHARACTERISTICS

Description	E Ride 21 (with one disc brush)	E Ride 21 (with two cylindrical brushes)
Voltage	24V	24V
Washed path	53 cm	51 cm
Suction	1168 mm H ² O	1168 mm H ² O
Detergent solution tank (or water for washing), capacity	55 L	55 L
Water recovery tank, capacity	55 L	55 L
Disc brush revolutions	175 rpm	-
Cylindrical brush revolutions	-	830 rpm
Number of disc brushes	1	-
Number of cylindrical brushes	-	2
Disc brush pressure	23 Kg	-
Cylindrical brushes pressure	-	25 Kg
Washing speed	3-5 Km/h	3-5 Km/h
Maximum speed	5 Km/h	5 Km/h
Maximum floor inclination for using the wash-and-dry machine	6 %	6 %
Maximum overcoming inclination of the wash-and-dry machine drive during transfers	25 %	25 %
No. Batteries	2 – 110 Ah	2 – 110 Ah
Inbuilt battery charger	Yes (optional)	Yes (optional)
Theoretical hour yield	2120 mq/h	2040 mq/h
Estimated hour yield	1270 mq/h	1220 mq/h
Endurance	2.30 h	2.30 h
MIT (Minuteman Injection Tecnology)	Yes	Yes
MIT, flow	0,4-3,8 L/min	0,4-3,8 L/min
MCS (Minuteman Chemical System)	Optional	Optional
MCS, ratio	1-5 %	1-5 %
Wash-and-dry machine passage width	65 cm	65 cm

Description	E Ride 21 (with one disc brush)	E Ride 21 (with two cylindrical brushes)
Wash-and-dry machine body dimensions, with squeegee and brush (length x height x width)	1200 x 1130 x 600 mm	1200 x 1130 x 600 mm
Wash-and-dry machine net weight (without batteries, with empty tanks, without driver)	148 Kg	145 Kg
Wash-and-dry machine gross weight (with batteries, with one full tank, without driver)	~ 250 Kg	~ 247 Kg
Drive motor	400 W	400 W
Disc brush motor	400 W	-
Motor cylindrical brushes	-	600 W
Motor suction	400 W, 3 stages	400 W, 3 stages
Manufacturing Regulations	CE	CE
Protection class	IPX 4	IPX 4
Level of acoustic pressure A at working position	72.4 dB (A)	72.4 dB (A)
Level of acoustic power A	87.6 dB (A)	87.6 dB (A)

3.5 ELECTRICAL DIAGRAM

Refer to the Service manual.

3.6 ELECTRICAL PROTECTIONS

Fuses

- The following fuse (22, **Figure 3-2**) is placed under the panel:
 - Fuse (F3) for protecting auxiliary services (10 A): (2, **Figure 4-2**)

For the other fuses present on the wash-and-dry machine, refer to the Service manual

3.7 WASH-AND-DRY MACHINE EQUIPMENT

The wash-and-dry machine is supplied with the following equipment versions:

STD Version:

- with squeegee
- without disc brush (or cylindrical brushes)
- without batteries
- without electronic battery charger onboard

B Version:

- with squeegee
- without disc brush (or cylindrical brushes)
- with batteries
- without electronic battery charger onboard

OBC Version:

- with squeegee
- with disc brush (or cylindrical brushes)
- without batteries
- with electronic battery charger onboard

COMPLETE Version:

- with squeegee
- with disc brush (or cylindrical brushes)
- with batteries
- with electronic battery charger onboard

DELUXE Version:

- with squeegee
- without disc brush (or cylindrical brushes)
- without batteries
- without electronic battery charger onboard
- with heel cushion (26, **Figure 3-2**)
- with wheel covers for rear wheels (27, **Figure 3-3**)
- with wings for rear wheels (28, **Figure 3-3**)

in addition:

The batteries can be of the following types:

- lead (WET)
- GEL
- AGM

3.8 OPTIONAL ACCESSORIES

Cylindrical brushes of different materials compared to the standard ones.

Oil-proof squeegee rubber blades.

Front and rear wheels of different materials

Washing detergent feeding system (MCS)

Blinking light.

Filling the detergent solution (or water for washing) tank extractable hose.

Filling the detergent solution (or water for washing) tank quick connection.

For further information on the wash-and-dry machine equipment and the above optional accessories, refer to your trusted Dealer.

CHAPTER 4 USE



WARNING!

On some points of the machine there are some adhesives indicating:

- DANGER
- WARNING
- CAUTION
- CONSULTATION

By means of this Manual, the operator must learn the meaning of these symbols.

Do not cover these plates for any reason, in case of damage replace them immediately.

4.1 BATTERIES CONTROL / INSTALLATION ON A NEW WASH- AND-DRY MACHINE



ATTENTION

The electric components of this machine can be seriously damaged if batteries are either installed or connected improperly. Batteries can be installed by qualified personnel only. Set the machine electronic board and the integrated battery charger according to the type of batteries used (WET, GEL, AGM batteries).

Check the batteries for damage before installation.

Disconnect the battery connector or the battery charger plug.

Move the batteries with great care.

Install the battery terminal protection caps supplied with the machine.

Alternatively, the wash-and-dry machine requires:

- 2 12V, 110 Ah (WET) batteries
- 2 12V, 110 Ah (GEL) batteries
- 2 12V, 110 Ah (AGM) batteries

The machine can be supplied as follow:

- a) **WET or GEL or AGM batteries supplied and already installed on the machine and ready to be used**
- b) **Without batteries**

According to these conditions, operate as described below.

- a) **WET or GEL or AGM batteries supplied and already installed on the machine and ready to be used**
 1. The machine is ready to be used.
- b) **Without batteries**
 2. Buy appropriate batteries (See paragraph "Technical Characteristics" Apply to battery qualified retailers to choose and install the battery.
 3. Install and set the machine batteries Service Manual according to the type of battery, as described in the following paragraph.

4.2 BEFORE STARTING THE WASH-AND-DRY MACHINE

General control

1. Visually check that the wash-and-dry machine is in good conditions; check that the disc brush (1, **Figure 4-1**) (or the cylindrical brushes) and the squeegee (2) are present and in good conditions.

Control of water recovery tank

2. Raise the cover (3, **Figure 4-1**) with its handle and check that the water recovery tank is empty, otherwise proceed with the emptying by acting as described in the related paragraph “tanks emptying”.

Water filling of the detergent solution (or water for washing) tank

- The tank can be filled in one of the following ways, according to the version of the nozzle present on the wash-and-dry machine.
3. (Basic version)
Unscrew the stopper (4, **Figure 4-1**), then introduce water through its nozzle (5).
Once the filling is completed, screw the stopper (4).
 4. (Version with extractable hose)
Unscrew the stopper (4, **Figure 4-1**), then extract the extractable hose (6) and position its opening (7) under a water tap and fill the tank. Once the filling is completed, insert the extractable hose in its place (6, **Figure 4-1**) and screw the stopper (4).
 5. (Version with quick connect stopper) Connect the water pipe equipped with a proper quick connection to the stopper (9) quick connection (8, **Figure 4-1**), then open the pipe tap, and let the water flow into the tank. Upon reaching the full tank, the water flow will

be stopped automatically by the quick connection (8).
Remove the water pipe from the quick connection (8).



ATTENTION!

The water temperature in the tank must not exceed 40 °C (100°F)

Addition of detergent in the water for washing tank (Only for the version without automatic detergent feeding system (MCS))

6. If present, remove the stopper (4, **Figure 4-1**) and add the detergent to the clean water present in the tank; follow the dilution instructions indicated on the label of the detergent container itself.
If the tank is too full, let enough water to flow out so to add the detergent.



ATTENTION!

Use a proper detergent for the type of cleaning to be carried out. Use exclusively low foaming and non-inflammable liquid detergents; suitable for the wash-and-dry machine to be used.

Filling of the detergent tank (Only for the version with automatic detergent feeding system (MCS))

7. If necessary, it is possible to remove the detergent tank from the wash-and-dry machine (10, **Figure 4-1**), by seizing its handle (11) and raising it.
8. Unscrew the stopper (12).
9. Introduce the washing detergent into the tank (10, **Figure 4-1**), then screw the stopper (12).
10. If removed, reinsert the tank (10, **Figure 4-1**) to its place in the wash-and-dry machine.



ATTENTION!

Use a proper detergent for the type of cleaning to be carried out. Use exclusively liquid detergents with low foamingness and non-inflammable; suitable for the wash-and-dry machine to be used.

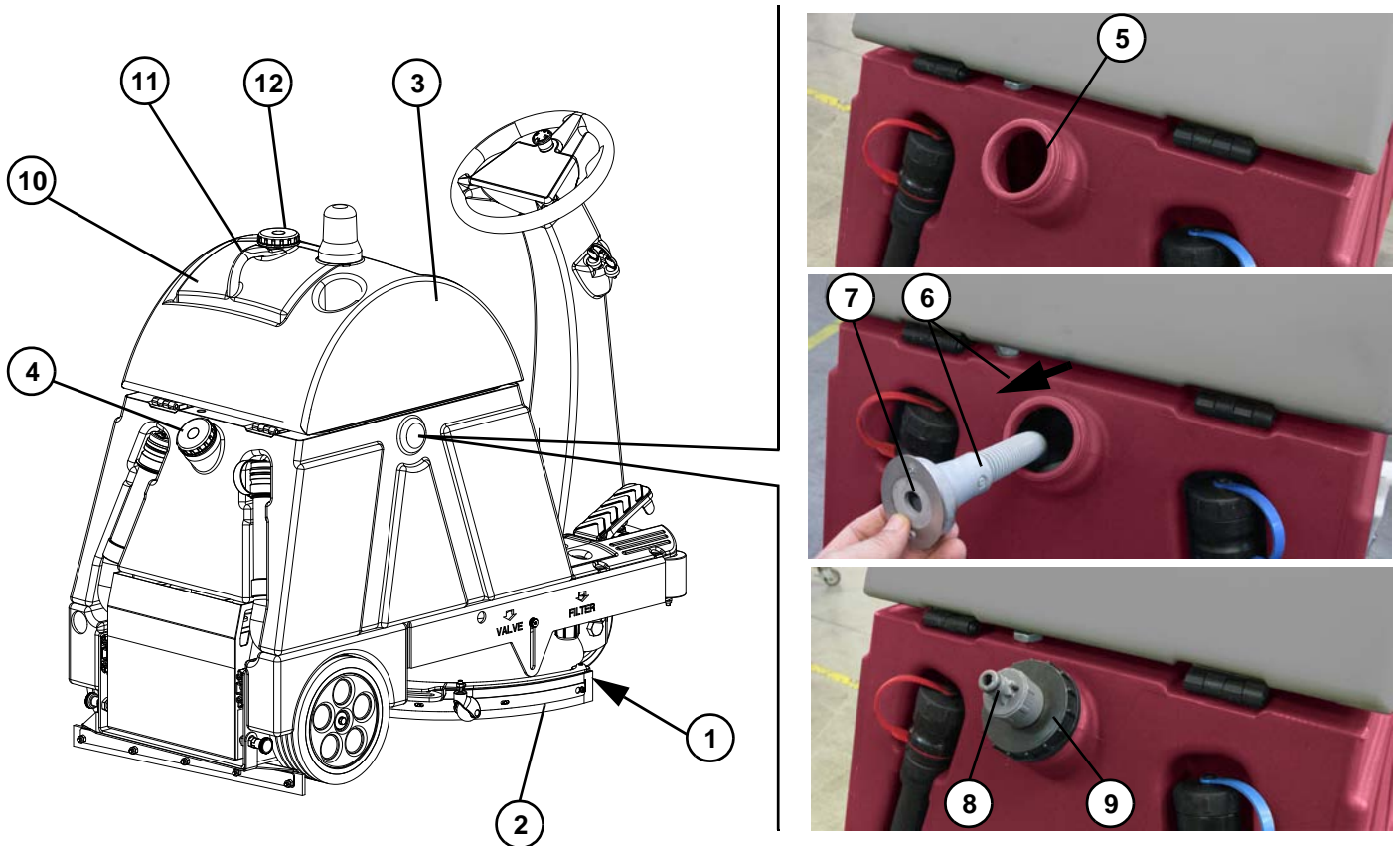

Figure 4-1

4.3 START UP AND STOPPING OF MACHINE

Start up

1. Prepare the machine as envisaged in the previous paragraph.
2. Seat up on the machine seat (7, **Figure 4-2**).
3. Turn the start up key (1, **Figure 4-2**) on "I"; wait a few seconds until on the display (3) appears the machine-is-ready caption (4) "READY".



ATTENTION!

Do not turn the start up key (1) without first seating on the seat (7), since a safety system consents use of the machine only when the operator is seated on the machine seat (7). It is absolutely forbidden to try to mishandle the above-mentioned seat safety system, or simulate in any way seating of the operator on the seat.

In the event that the start up key is turned (1, **Figure 4-2**) without being seated on the seat, in the display area (4) appears caption "SIT DOWN" and no function of the machine is available.

When the display shows indications other than those described, it is necessary to request action by the Minuteman Assistance Service.

4. Check the state of the battery charges by observing the percent indication (5, **Figure 4-2**) and the graphic indication (6).
If necessary proceed in charging the batteries; see specific paragraph of chapter Maintenance.



ATTENTION!

The machine is not suitable to be used on ruined, uneven floors.

5. Go to the workplace, by starting up the machine with the hands on the steering wheel and by pressing the pedal (2, **Figure 4-2**).

The speed of moving is adjustable from zero to its maximum set value, depending on the pressure exerted on the pedal (2, **Figure 4-2**)

6. If necessary, through the buttons (8, **Figure 4-2**) adjust the capacity of the detergent solution (or water for washing).
7. (Optional) If necessary, through the buttons (9, **Figure 4-2**) adjust the percentage of the detergent for washing.
8. If necessary, through the button (10, **Figure 4-2**) adjust the maximum speed of the machine.
9. To start washing the pavement, activate the disc brush (or cylindrical brushes) through the button (11, **Figure 4-2**).
10. To start drying of the pavement, activate suction through the button (12, **Figure 4-2**).
11. To start both washing and drying of the pavement, activate the button (13, **Figure 4-2**).
12. Start cleaning work by handling through the hands the steering wheel (14, **Figure 4-2**) and by driving forward the machine by pressing appropriately the pedal (2).

Stopping the machine

13. Release the pedal (2, **Figure 4-2**).
14. Press the buttons (11, **Figure 4-2**) or (12) or (13,) to deactivate and lift the respective active operations. Suction stops a few seconds after activation of the related button, for sucking all the water present in the piping.
15. Turn the start up key (1, **Figure 4-2**) on "0", and then extract it.
16. If necessary, proceed with emptying the tanks, operating as described in the specific paragraph.



ATTENTION!

Do not leave the machine unattended without ascertaining that it does not move autonomously.

Do not leave the machine unattended without removing the start up key.

17. To stop immediately the machine in the event of an emergency, press the button (15, **Figure 4-2**).
To cut out the emergency button (15), turn it clockwise until unhooking it from the lower position.

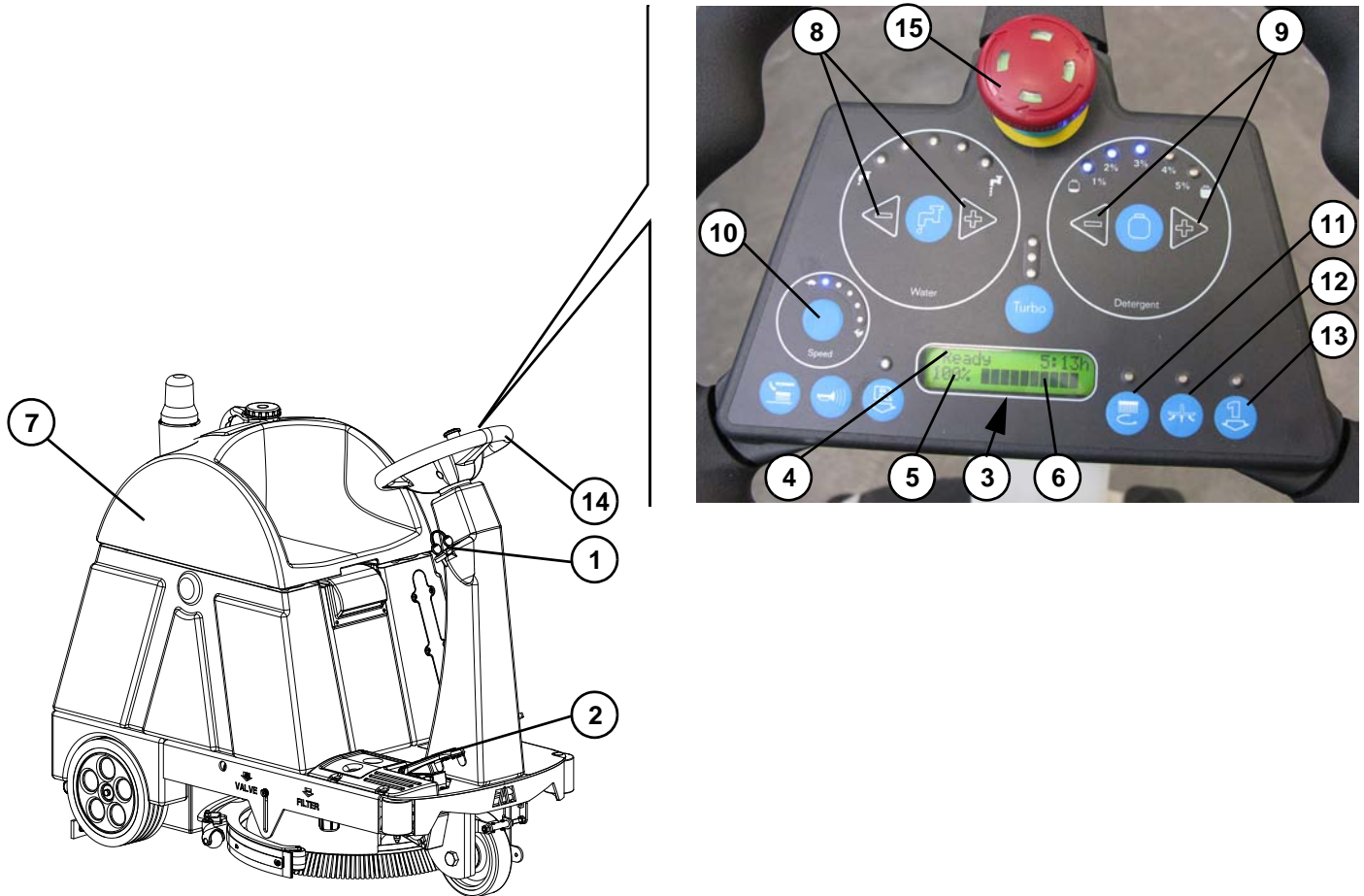

Figure 4-2

4.4 WASH-AND-DRY MACHINE IN OPERATION

1. During operation, check the state of the batteries charge to avoid flat batteries in inaccessible battery recharge points.
2. Check also periodically the residual quantity of detergent solution (or water for washing), through its level indicator.
3. If the water recovery tank fills during use of the wash-and-dry machine, suction is automatically stopped. To start suction again, it is necessary to empty the water recovery tank (see related paragraph).
4. If necessary, at the end of the operation, proceed with emptying the tanks (see related paragraph).

4.5 AFTER MACHINE USE

At the end of the work, before leaving the machine: Disconnect the brush in the following way:

1. Empty the tank of water recovery, as listed in the following paragraph.
2. Clean the disc brush (or cylindrical brushes) and the squeegee, as listed in the Maintenance Chapter.
3. If necessary, recharge the battery as listed in the Maintenance Chapter.
4. Leave the machine in a dry and clean place, with brush and squeegee lifted.

4.6 EMPTYING THE TANKS

Emptying the tank from water recovery

1. Take the wash-and-dry machine to the suitable area for draining the water recovery, in full compliance of the anti-pollution regulations in force.
2. Disengage the hose (1, **Figure 4-3**) from its seat and raise it beyond the upper edge of the tank until its area (2) is water free; then, by keeping it in this position, unscrew the stopper (3).

3. Bend manually the hose in the area (2) until obtaining a watertight fold (17); then, by keeping it bent, lower it on the drain area.
4. Release gradually (in order to avoid undesired squirts) the fold (17) by letting the dirty water flow out from the tank into the drain area.
5. With the handle (4, **Figure 4-3**), raise the cover of the tanks (5) and, if necessary, wash the water recovery tank (6); wash also the related lower side (7) of the cover and perimeter gasket (8).
Check that the perimeter gasket (8) is whole: if damaged, it can jeopardise the good functioning of the dirty water suction.



WARNING!

Do not damage the float (9, Figure 4-3)

6. Let all the water for washing flow out of the hose (1, **Figure 4-3**), then screw the stopper (3) and engage the hose (1) on its seat in the wash-and-dry machine.

Detergent solution (or water for washing) tank emptying

7. Take the wash-and-dry machine to the suitable area for draining the detergent solution (or water for washing), in full compliance of the anti-pollution regulations in force.
8. Disengage the hose (10, **Figure 4-3**) from its seat and raise it beyond the upper edge of the tank until its area (11) is free from water; then, by keeping it in this position, unscrew the stopper (12).
9. (Only for optional hose that can be pressed in the area (11)): Bend manually the hose in the area (11) until obtaining a watertight fold (17); then, by keeping it bent, lower it on the drain area.
Release gradually (in order to avoid undesired squirts) the fold (17) by letting the detergent solution (or water) flow out from the tank into the drain area.

(Only for the hose that cannot be pressed in the area (11)). Lower gradually (in order to avoid undesired squirts) the hose (10) above the drain area, by letting the detergent solution (or water) flow out from the tank into the drain area.

10. If necessary, wash the detergent solution (or water for washing) tank after unscrewing the stopper (13).
11. Let all the water for washing flow out of the hose (10, **Figure 4-3**), then screw the stopper (12) and engage the hose (10) on its seat in the wash-and-dry machine.

Emptying of the washing detergent tank (Optional)

12. Remove the detergent tank from the wash-and-dry machine (14, **Figure 4-3**), by seizing its handle (15) and raising it.
13. Unscrew the stopper (16) and let the washing detergent flow out of the tank in the suitable area for draining the washing detergent.
14. If necessary, wash the washing detergent tank.
15. Screw the stopper (16, **Figure 4-3**) and place the tank (14) in its seat in the wash-and-dry machine.

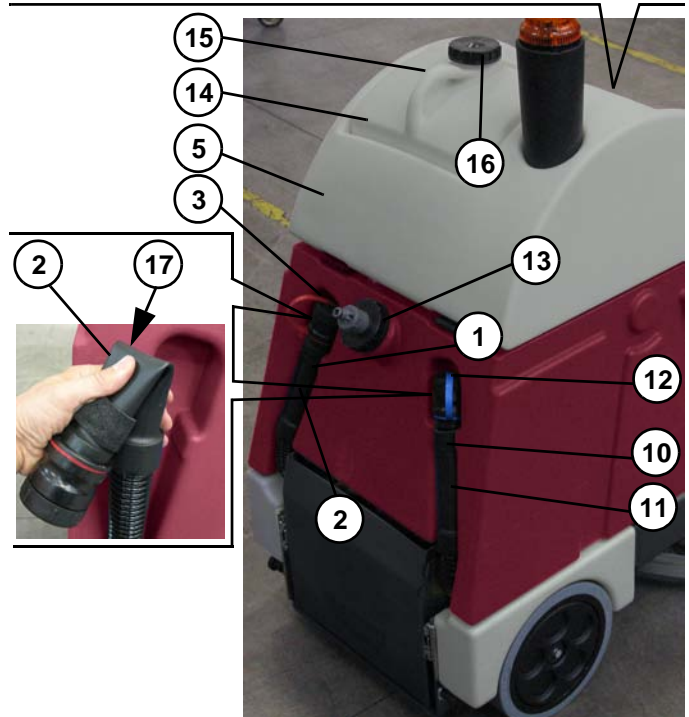
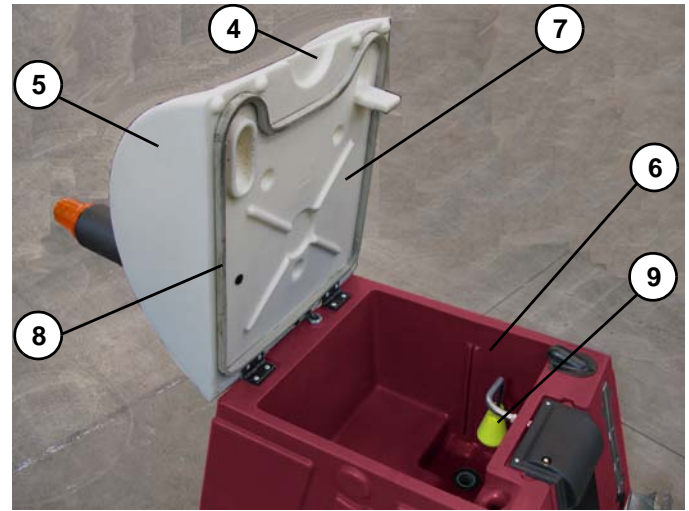

Figure 4-3

4.7 WASH-AND-DRY MACHINE PUSH/ DRAWING MOVEMENT

When it is not possible to use the wash-and-dry machine drive, it is possible to move it by pushing it manually.



ATTENTION!

The wash-and-dry machine is not suitable to be pushed on floors with excessive slopes; precautions must be taken in advance in relation to the wash-and-dry machine (gross weight with 50 liters of water in tanks: about 250 Kg)

4.8 LONG INACTIVITY OF THE WASH- AND-DRY MACHINE

If it is intended not to use the wash-and-dry machine for a period longer than 30 days, it is appropriate to perform the following operations:

1. Carry out what is indicated in paragraph "After Use of the Wash-and-dry Machine".
2. Empty the detergent solution (or water for washing) tank by acting as described in the related paragraph.
3. Empty the washing detergent tank (optional) by acting as described in the related paragraph.
4. Disconnect the connector of the batteries, by acting as described further down.

Remove the left pin (1, **Figure 4-4**), then rotate it by half turn, and block it in the removed position.

Remove the right pin (2, **Figure 4-4**), then remove the battery holder case (3) by the handles (4). Disconnect the connector (5) of the batteries. Insert again the battery holder case in its seat (3, **Figure 4-4**) and let it engage to the retainer (2) and retainer (1) after unblocking it.

5. Clean the detergent feeding system (optional), by acting as described in chapter "Maintenance".

4.9 FIRST PERIOD OF USE

After the first period of use (first 8 hours) it is necessary to check that the fixing and connecting elements are correctly fixed, that the visible parts are integral and that there are no leakages.

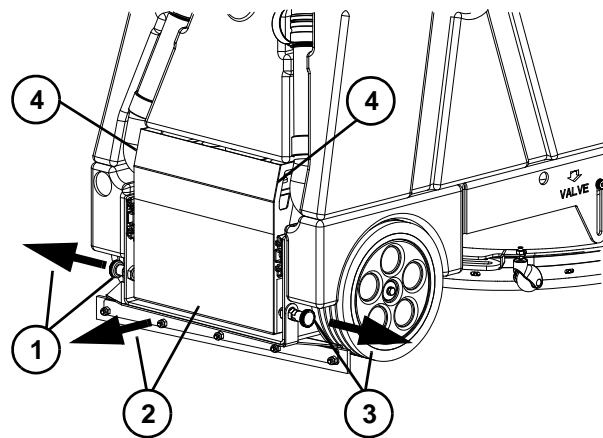

Figure 4-4

CHAPTER 5 MAINTENANCE

The machine proper and safe operation is guaranteed by a careful and constant maintenance.

The following table sums up the scheduled maintenance. The indicated periods can be subjected to variations according to working conditions. These must be defined by the person in charge for the maintenance.



WARNING!

The operations must be carried out with the machine off and the battery disconnected. Moreover, read carefully the instructions in the Safety chapter before performing any maintenance operation.

All periodic or extraordinary maintenance operations must be performed by skilled personnel, or by an authorized Service Center.

This Manual contains the Scheduled Maintenance Table and describes only the easiest and most common maintenance procedures.



REMARK:

For other maintenance procedures contained in the Scheduled Maintenance Table see the specific “Service Manual” that can be consulted at any Service Center.

5.1 SCHEDULED MAINTENANCE TABLE

Operation	Daily, after using the wash-and-dry machine	Monthly or every 100 hours	Half-yearly or every 400 hours	Yearly or every 800 hours
Squeegee cleaning	●			
Disc brush cleaning (or cylindrical brushes)	●			
Battery charge	●			
Squeegee rubber blades check/replacement		●		
Cleaning of the detergent solution (or water for washing) filter		●		
Cleaning of nozzles and filters		●		
Screws and nuts tightening check			● (1)(2)	
Check of HEPA suction filter			● (2)	
Brushes rotation belt check/replacement				●(2)
Drive chain check/replacement				●(2)

(1): and after the first 8 working hours

(2): maintenance, falling within the competence of a Minuteman Authorized Service Center

5.2 SQUEEGEE CLEANING



NOTE

To obtain a good floor drying, the squeegee must be cleaned and the rubber blades must be in good conditions.



ATTENTION!

The use of work gloves is recommended during the squeegee cleaning due to the possible presence of sharp debris.

1. If necessary, remove the squeegee (See procedure in the related paragraph).
2. Wash and clean the squeegee (1, Figure 5-1); in particular, clean the dirt and debris in the spaces (2) and hole (3). Check that the front rubber blade (4) and the rear rubber blade (5) are whole and do not show cuts or tears, otherwise replace them (see procedure in the related paragraph).
3. If removed, replace the squeegee (See procedure in the related paragraph).

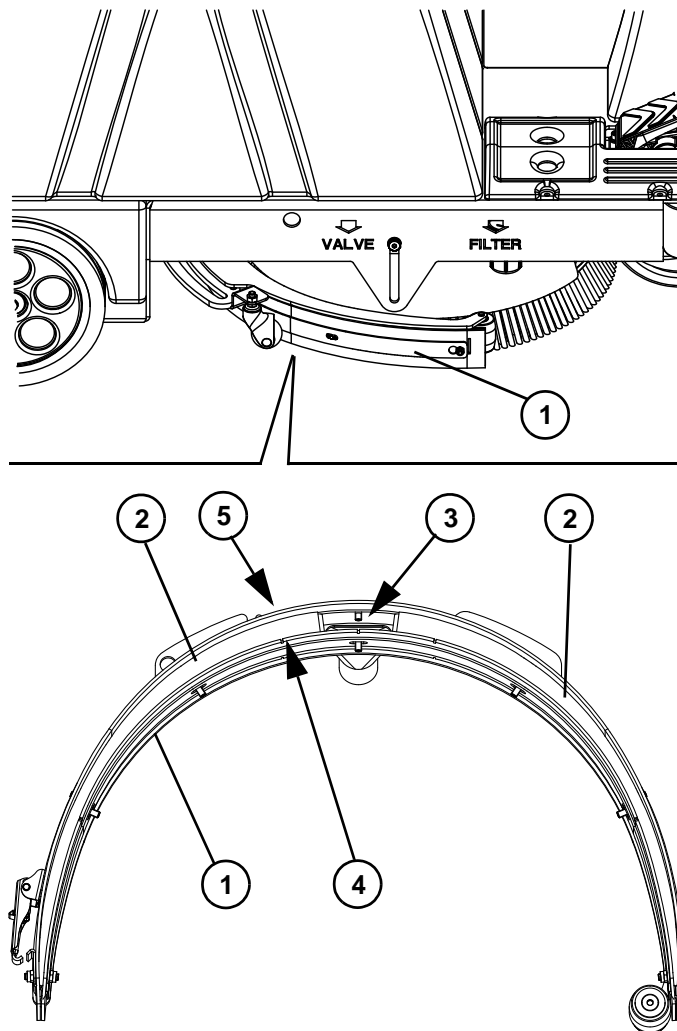

Figure 5-1

5.3 CHECKING/SUBSTITUTION OF THE SQUEEGEE RUBBERS

1. Disassemble and clean the squeegee, by operating as described in the specific paragraph.
2. Check that the front rubber (1, **Figure 5-2**) and the rear rubber (2), are whole and are without cuts and tears, otherwise substitute them, as described below. Check also that the front edge (3) of the rear rubber (2) is not worn out; otherwise turn upside-down this rubber, by bringing in its place one of the other three edges, if still whole. Should also the other three edges be worn out, substitute the rubber, by operating as described below:
 - Substitute (or turn upside-down) the rear rubber (2, **Figure 5-2**) after having released the stop (4), unhooked the eccentric (5), and removed the stop band (7) by releasing them from the dowels with nut (6); finally, refit the rubber by operating in reverse order with respect to the removal.
 - Substitute the front rubber (1, **Figure 5-2**) after having unscrewed the nuts (8) and removed the stop band (9); finally, refit the rubber by operating in reverse order with respect to the removal.
3. Refit the squeegee by operating as described in the specific paragraph.
4. If necessary, carry out the height Adjustment of the squeegee by operating as described in the following paragraph.

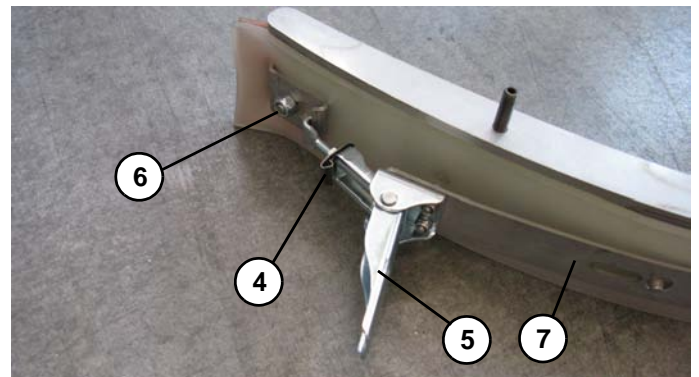
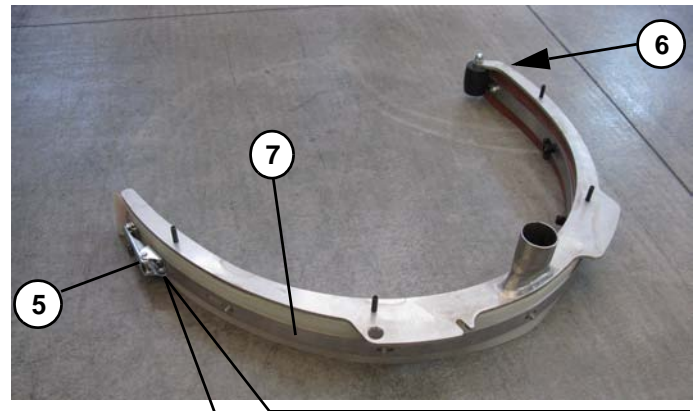
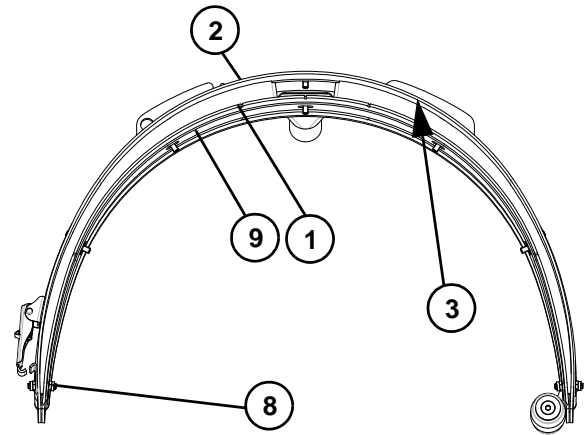

Figure 5-2

5.4 HEIGHT ADJUSTMENT OF SQUEEGEE

- The adjustment of the squeegee height is necessary when the wash-and-dry machine does not provide correct drying, leaving trails of water in the central or external parts.
1. To adjust the squeegee height, loosen the nuts (1, Figure 5-3) and adjust the left and right wheel height (2).
 2. At the end of the adjustment, tighten the nuts.

5.5 BRUSH CLEANING



CAUTION!

It is advisable to use protective gloves when cleaning the disc brush because there can be cutting debris.

1. If necessary, remove the disc brush (See procedure in the related paragraph).
2. Wash and clean the disc brush (1, Figure 5-4) from dirt and debris
3. If removed, replace the disc brush (See procedure in the related paragraph).
4. The disc brush must be replaced for excessive wear and tear, when in the lowered brush condition, the lateral pins (2, Figure 5-4) lean on the lower ends (3) of the slots.

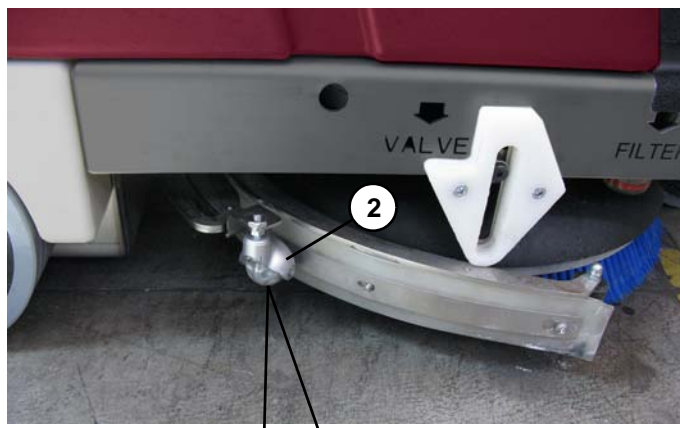

Figure 5-3

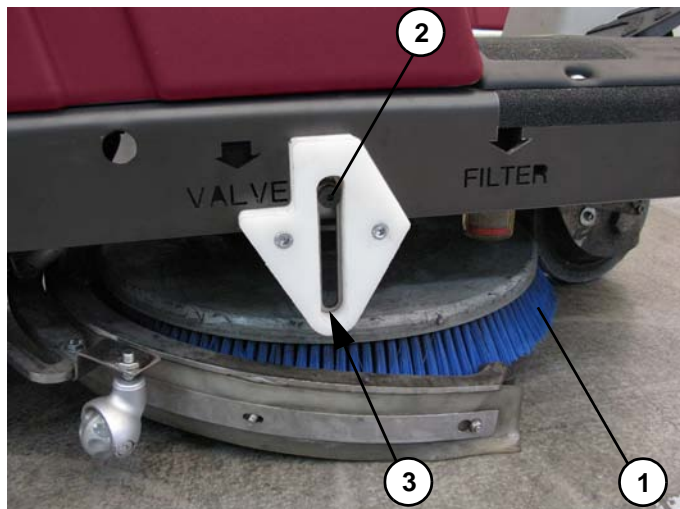

Figure 5-4

5.6 CYLINDRICAL BRUSH CLEANING



CAUTION!

It is advisable to use protective gloves when cleaning the cylindrical brush because there can be cutting debris.

1. Remove the cylindrical brushes (See procedure in the related paragraph).
2. Wash and clean the cylindrical brushes from dirt and debris.
3. Wash and clean the cylindrical brushes cases too (1, **Figure 5-5**). Check that the drive hubs (2) of the cylindrical brushes are free from dirt debris or twisted objects (ropes, etc.).
4. Replace the cylindrical brushes (See procedure in the related paragraph).
5. The cylindrical brushes must be replaced for excessive wear and tear, when in the lowered brush condition, the lateral pins (1, **Figure 5-5**) lean on the lower ends (2) of the slots.

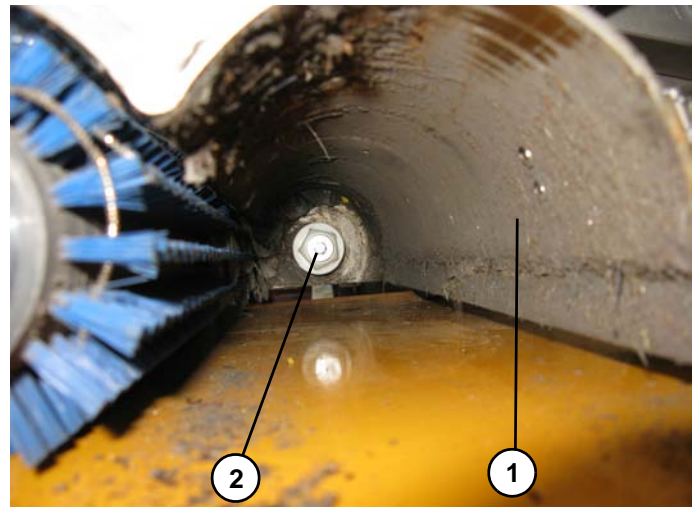

Figure 5-5

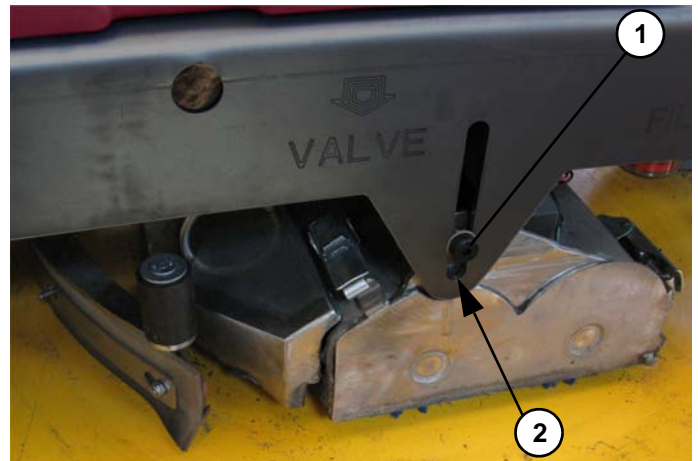

Figure 5-6

5.7 CLEANING THE DETERGENT SOLUTION (OR WATER FOR WASHING) FILTER

1. Ascertain that the wash-and-dry machine cannot move autonomously.
2. By acting on the wash-and-dry machine controls, lower the squeegee and the disc brush (or cylindrical brushes), then rotate the ignition key on "0" and extract it (see chapter Use).
3. Close the water/detergent solution flow tap (1, **Figure 5-7**) by acting on the right side of the wash-and-dry machine.
4. Unscrew and remove the filter transparent cover (2).
5. Remove the filter (3) from the transparent cover (4).
6. Clean the filter (3) and the transparent cover (4).
7. Replace the filter (3) in its transparent cover case (4).
8. Screw the filter transparent cover to its seat (2).
9. Open the tap (1).
10. Rotate the ignition key on "1" and wait for the squeegee and disc brush (or cylindrical brushes) lifting, then rotate the ignition key on "0" and extract it.

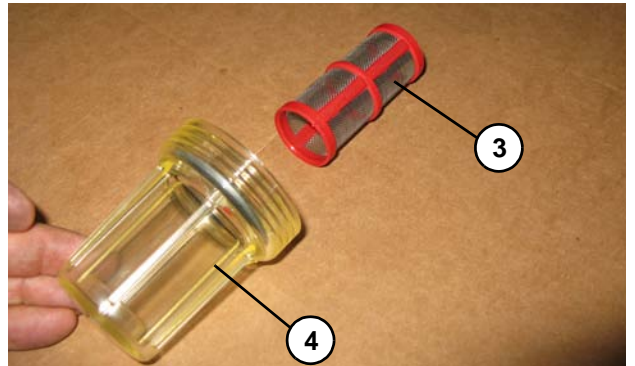
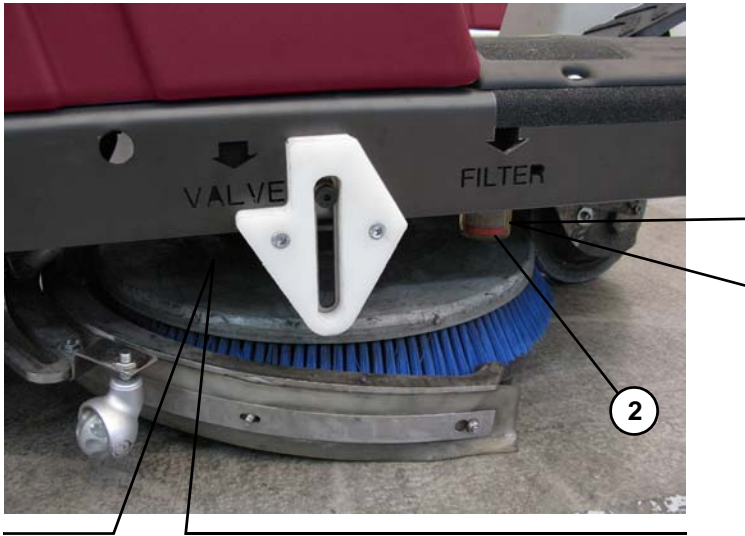

Figure 5-7

5.8 CLEANING THE NOZZLE AND FILTER DETERGENT SOLUTION SUPPLY TO THE DISC BRUSH

1. Ascertain that the wash-and-dry machine cannot move autonomously.
2. Remove the brush (See procedure in the related paragraph).
3. By acting on the coupling hub (1, **Figure 5-8**) of the brush, unscrew the ring nut (2) and recover the nozzle (3) and the gasket (4).
4. Remove the filter from its seat (5).
5. Clean the nozzle (3) and the filter (5).
6. Replace the filter correctly (5) in its case.
7. Place the nozzle (3) and the gasket (4) in their seat and then screw the ring nut (2).
8. Replace the brush (See the procedure in the related paragraph).

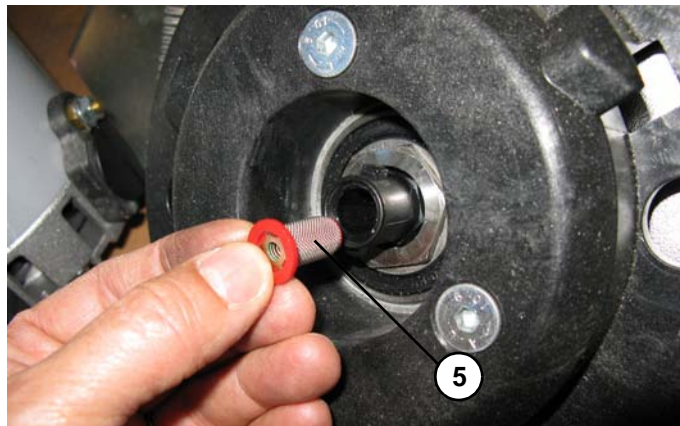
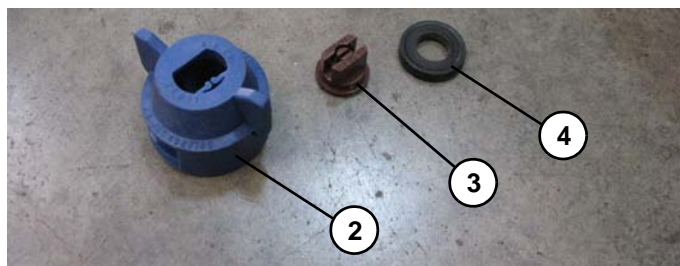
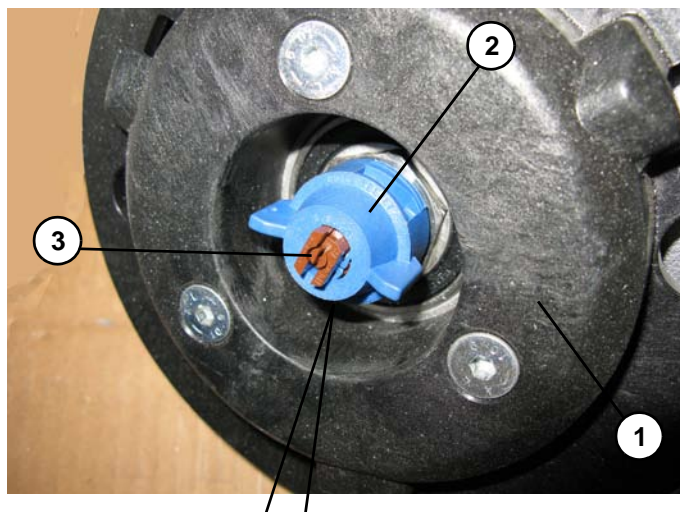

Figure 5-8

5.9 CLEANING THE NOZZLE AND FILTER DETERGENT SOLUTION SUPPLY TO THE CYLINDRICAL BRUSHES

1. Ascertain that the wash-and-dry machine cannot move autonomously.
2. By acting on the wash-and-dry machine controls, lower the cylindrical brushes, then rotate the ignition key on "0" and extract it (see chapter Use).
3. By acting on the front part of the cylindrical brush-holder head, unscrew the ring nut (1, **Figure 5-9**) and recover the nozzle (2) and the gasket (3).
4. Remove the filter from its seat (4).
5. Clean the nozzle (2) and the filter (4).
6. Replace the filter correctly (4) in its case.
7. Place the nozzle (2) and the gasket (3) in their seat and then screw the ring nut (1).
8. Rotate the ignition key on "I" and wait for the lifting of the cylindrical brushes, then rotate the ignition key on "0" and extract it.

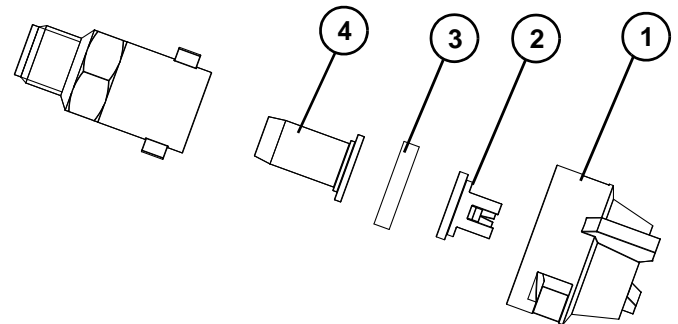
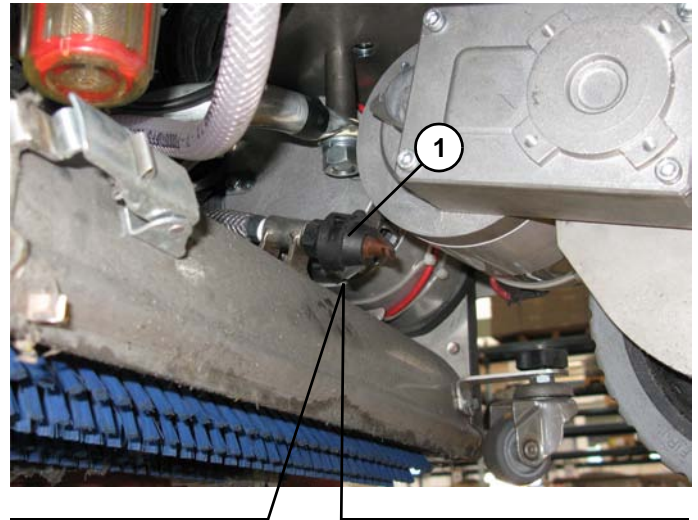

Figure 5-9

5.10 CLEANING THE DETERGENT FEEDING SYSTEM (OPTIONAL)

1. Empty and clean the washing detergent tank, by acting as described in the related paragraph.
2. Put about one litre of clean water into the washing detergent tank.
3. Use the wash-and-dry machine by simulating the washing activity, for the time necessary to clean the detergent feeding system (15-30 minutes), by adjusting the clean water and "detergent" flows to the maximum values.
4. Finally, remove the residual water from the washing detergent tank.
5. If necessary, perform the other intended procedures "After use of the wash-and-dry machine" (See the related paragraph).

5.11 BATTERY CHARGE



CAUTION!

Keep the batteries charged make their life last longer.



CAUTION!

When the batteries are discharged, recharge them as soon as possible, as that condition makes their life shorter.

Check for battery charge at least once a week.



CAUTION!

For machines not equipped with on board battery charger, the battery charger must be appropriate for the battery installed on the machine.



WARNING!

Battery charging of WET batteries produces explosive hydrogen gas. Charge the batteries only in well-ventilated areas and far from naked flames.

Do not smoke during battery charging.

Keep the tank assembly open while recharging the battery.



WARNING!

Pay attention during battery recharging because there can be battery liquid leakages. The battery liquid is corrosive. If it comes in contact with the skin or eyes, rinse thoroughly with water and consult a physician.

Battery charge for wash-and-dry machines without on board battery charger

1. Take the wash-and-dry machine to the area suited for recharging the batteries.
2. Ascertain that the wash-and-dry machine cannot move autonomously.
Rotate the ignition key on "0" and extract it.
3. By acting of the rear side of the wash-and-dry machine, remove the left pin (1, **Figure 5-10**), then rotate it by half turn, and block it in the removed position.
4. Remove the right pin (2, **Figure 5-10**) and, carefully, remove completely the battery holder case (3) by the handles (4), then engage the pin (2) on the related locking hole of the extracted case.
5. Only for lead batteries (WET):
 - check the correct electrolyte level in the batteries (7, **Figure 5-10**); if necessary, restore it through the stoppers (8).
 - let all the stoppers (8) open for the next recharge.
 - clean (if necessary) the upper surface of the batteries.
6. Check the suitability of the battery charger to be used by referring to the instructions of the battery charger itself. The nominal voltage of the battery charger must be equal to 24V.
7. Disconnect the connector of the batteries (5, **Figure 5-10**).
8. Connect the connector (6, **Figure 5-10**) to the external battery charger.
9. Connect the battery charger to the electrical network. The charge of the batteries has started.
10. At the end of the recharge, disconnect the battery charger from the electric network and the battery connector (6, **Figure 5-10**).
11. (only for lead batteries (WET)) Check the correct electrolyte level in the batteries, then close all the stoppers (8, **Figure 5-10**).

12. Connect again the connector (5, **Figure 5-10**) to the connector (6).
13. Extract the pin (2) and place the battery case into its seat, then engage the pin (2) to the battery case itself.

14. Unblock and engage the pin (1) to the battery case.
15. The charge has ended.

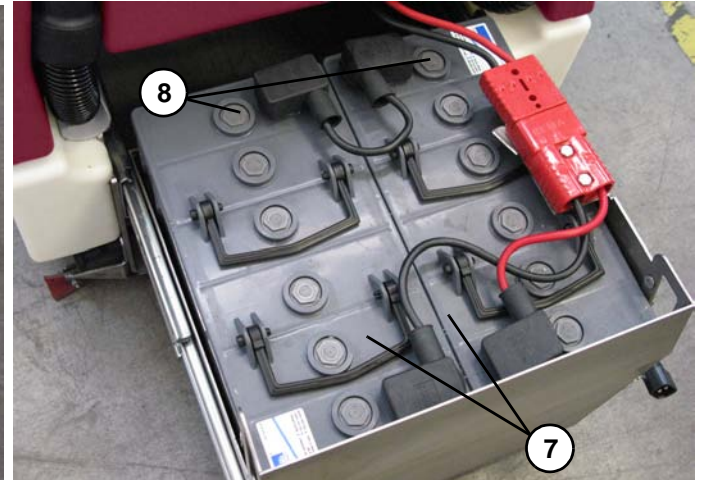
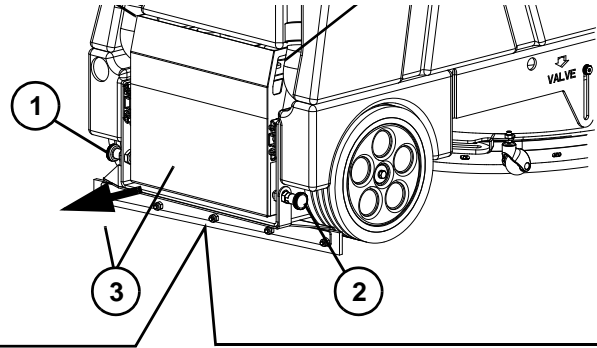

Figure 5-10

Battery charge for wash-and-dry machines with on board battery charger (optional)

1. Take the wash-and-dry machine to the area suited for recharging the batteries.
2. Ascertain that the wash-and-dry machine cannot move autonomously.
3. By acting on the rear side of the wash-and-dry machine, remove the left pin (1, **Figure 5-12**), then rotate it by half turn, and block it in the removed position.
4. Remove the right pin (2, **Figure 5-12**) and, carefully, remove completely the battery holder case (3) by the handles (4), then engage the pin (2) on the related locking hole of the removed case.
5. Only for lead batteries (WET):
 - check the correct electrolyte level in the batteries (7, **Figure 5-12**); if necessary, restore it through the stoppers (8).
 - let all the stoppers (8) open for the next recharge.
 - clean (if necessary) the upper surface of the batteries.
6. Connect the connector (5) to the electrical network, after checking that the nominal voltage of the network is that envisaged for the charge of the wash-and-dry machine (Refer to the technical data plate of the letter).

The charge of the batteries has started.



NOTE

When the battery charger is connected to the network, all the functions of the wash-and-dry machine are automatically excluded.

7. The charge has ended when on the display (1, **Figure 5-11**) appears “100 %” and all the bars are full (2).
8. Disconnect the electrical connection (5, **Figure 5-12**) from the network.

9. (only for lead batteries (WET)) Check the correct electrolyte level in the batteries, then close all the stoppers (8, **Figure 5-12**).
10. Extract the pin (2, **Figure 5-12**) and place the battery case into its seat; then engage the pin (2) to the battery case itself.
11. Unblock and engage the pin (1, **Figure 5-12**) to the battery case.
12. The charge has ended.

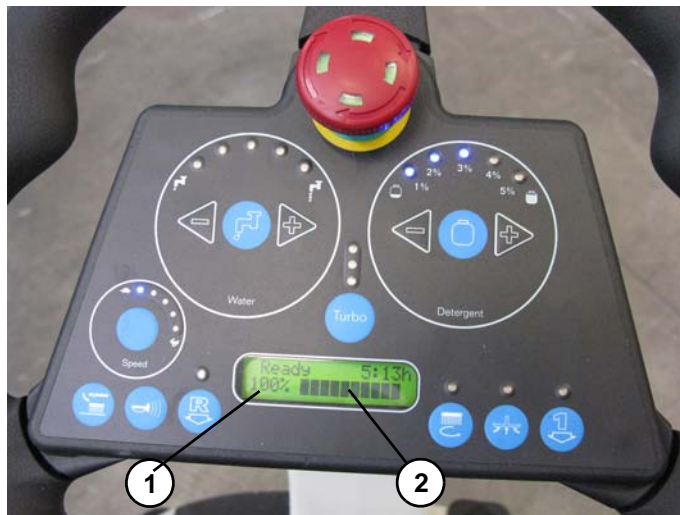

Figure 5-11

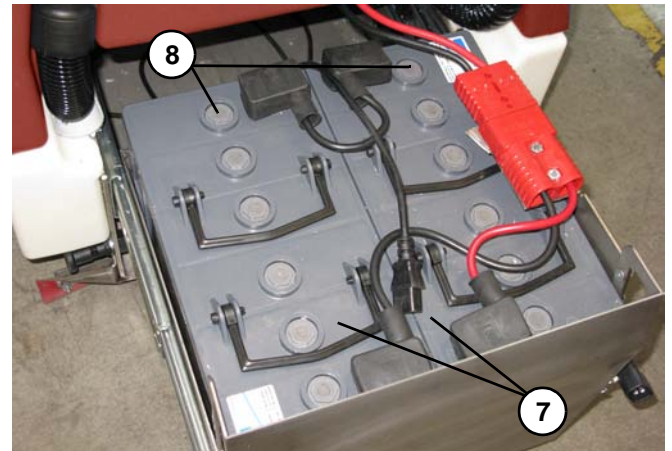
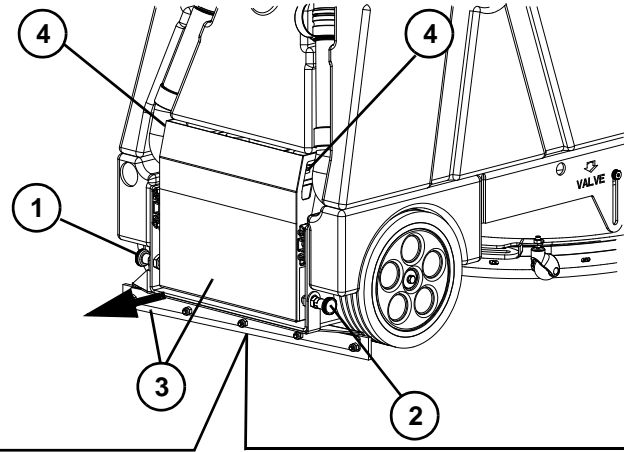

Figure 5-12

5.12 CHECKING/REPLACING THE FUSES

1. Ascertain that the wash-and-dry machine cannot move autonomously.
2. Rotate the ignition key on "0" and extract it.
3. Disconnect the connector from the batteries, by acting as described further down.
Remove the left pin (1, **Figure 5-14**), then rotate it by half turn, and block it in the removed position.
Remove the right pin (2, **Figure 5-14**), then remove the battery holder case (3) by using the handles (4).
Disconnect the connector of the batteries (5).
4. Raise the cover (5, **Figure 5-15**), remove the panel (1) by seizing it on the hold (3) and raising it to disengage it from the retainers (4). Close the cover (5).
5. Check / replace the fuses:
 - 10A Fuse for protecting auxiliary services (2, **Figure 5-15**)
6. Place the panel into its seat (1, **Figure 5-15**) and engage the retainers (4).
7. Connect the connector of the batteries (5, **Figure 5-14**).
8. Replace the batteries case to its seat (3, **Figure 5-14**) and engage it to the retainer (2) and retainer (1) after unblocking it.

5.13 ASSEMBLY-DISASSEMBLY OF THE SQUEEGEE

Disassembly

1. Ascertain that the wash-and-dry machine cannot move autonomously.
2. Rotate the ignition key on "0" and extract it.
3. By acting of the left side of the wash-and-dry machine, with the squeegee in raised position, move slightly the squeegee outwards (1, **Figure 5-13**), then loosen its fastening knob (2).
4. Disconnect the suction pipe (3, **Figure 5-13**) from the squeegee.

5. Remove the squeegee (1).

Assembly

6. Assemble in the reverse order with respect to disassembly

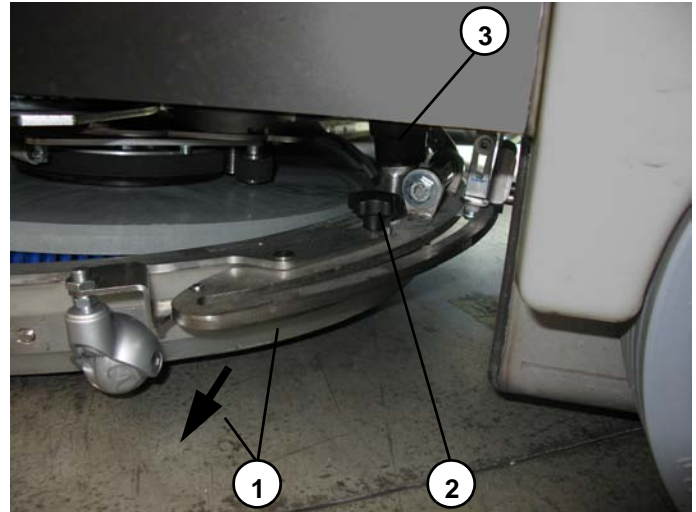

Figure 5-13

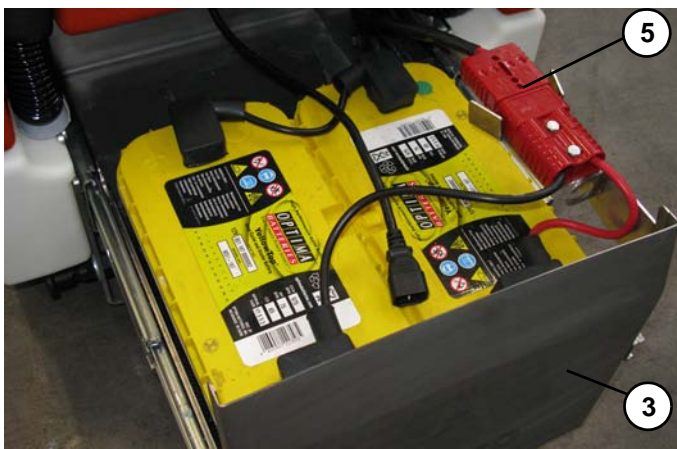
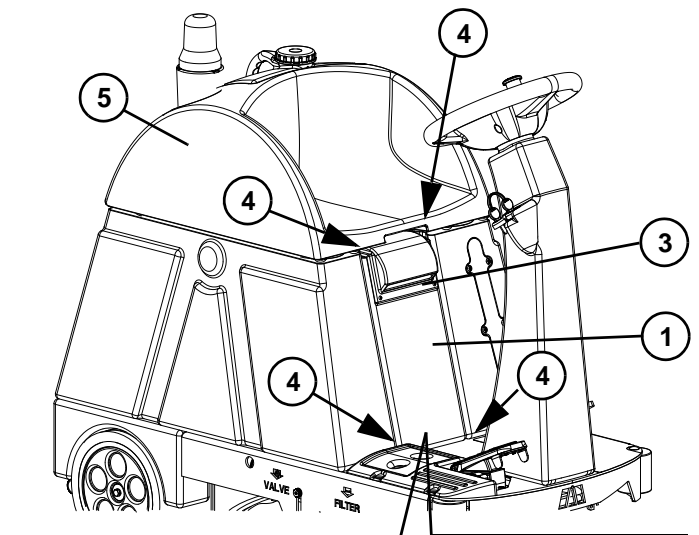
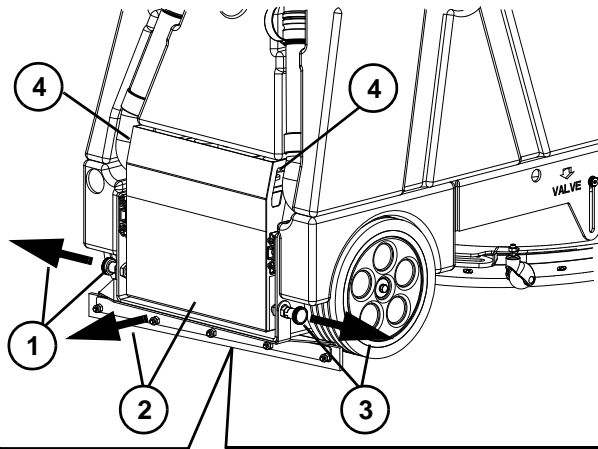

Figure 5-14

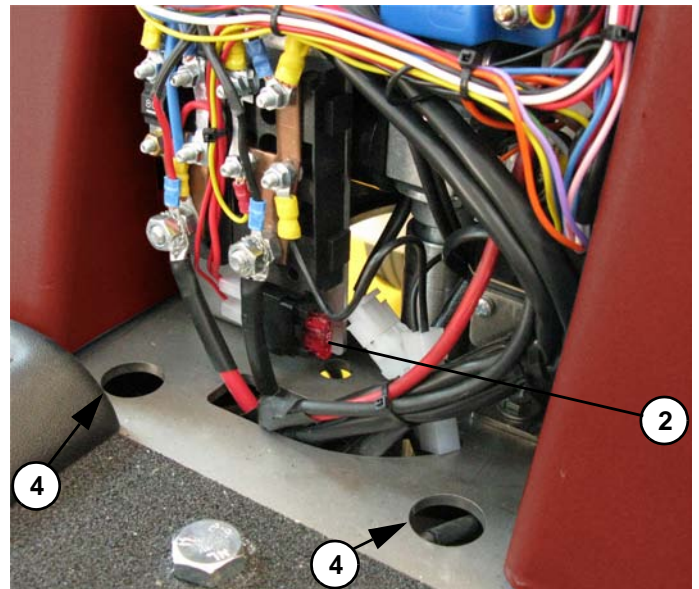

Figure 5-15

5.14 ASSEMBLY-DISASSEMBLY OF THE DISC BRUSH

Disassembly

1. Ascertain that the wash-and-dry machine cannot move autonomously.
2. Sit on the wash-and-dry machine seat and rotate the ignition key (1, **Figure 5-16**) on "I", then wait for a few seconds so that on the display (3) appears caption (4) "READY" indicating that the wash-and-dry machine is ready for use.
3. Press the button (5, **Figure 5-16**) to release the brush and wait for a few seconds that the wash-and-dry machine releases the brush after activating it.
4. Rotate the ignition key (1, **Figure 5-16**) on "0" and then extract it.
5. Move slightly the squeegee (6, **Figure 5-16**) and recover the disc brush (7).

Assembly

6. Ascertain that ignition key (1, **Figure 5-16**) is on "0".
7. Ascertain that the coupling hub of the disc brush is in the raised position.
8. Place the disc brush (7, **Figure 5-16**) below the wash-and-dry machine, by centring it on the coupling hub.
9. Sit on the seat and rotate the ignition key (1, **Figure 5-16**) on "I", and wait for a few seconds so that on the display (3) appears caption (4) "READY" indicating that the wash-and-dry machine is ready for use.
10. Press the brush lowering and rotation (8, **Figure 5-16**) activation button.
11. Press slightly and only for an instant the pedal (2, Fig. R), by determining the lowering of the hub that will couple the brush.

In case of non-coupling of the brush, get out of the wash-and-dry machine and reposition the brush on the coupling hub which will have remained lowered (therefore, the alignment operation will be facilitated).

12. Repeat the operations described in the previous points 9, 10 and 11.
13. Rotate the ignition key (1, **Figure 5-16**) on "0" and then extract it.

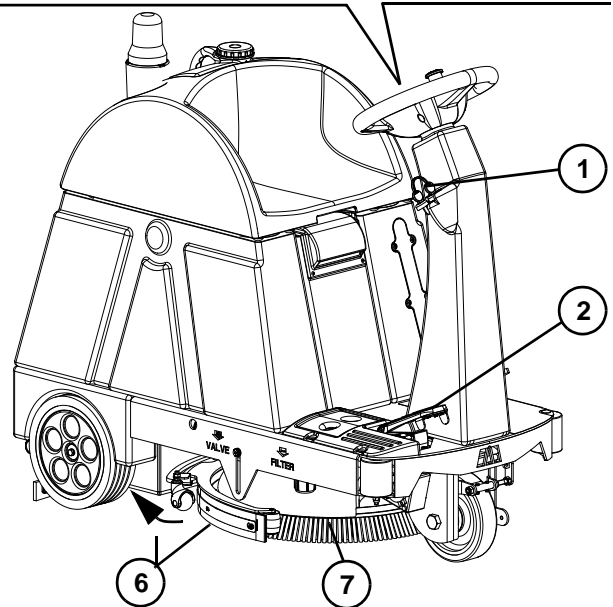
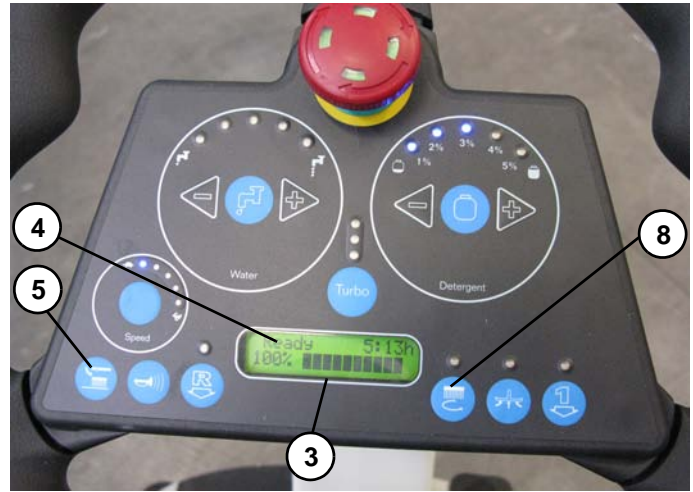

Figure 5-16

5.15 CYLINDRICAL BRUSHES ASSEMBLY-DISASSEMBLY

Disassembly

1. Ascertain that the wash-and-dry machine cannot move autonomously.
2. By operating on the wash-and-dry machine controls, lower the cylindrical brushes then rotate the ignition key on "0" and extract it (see the chapter Use).
3. By operating on the right side of the wash-and-dry machine, release the retainers and cam (1, **Figure 5-17**).
4. Remove the cover (1, **Figure 5-18**) by disengaging the supports (2) from the cylindrical brushes (3).
5. Extract the cylindrical brushes (3, **Figure 5-19**).

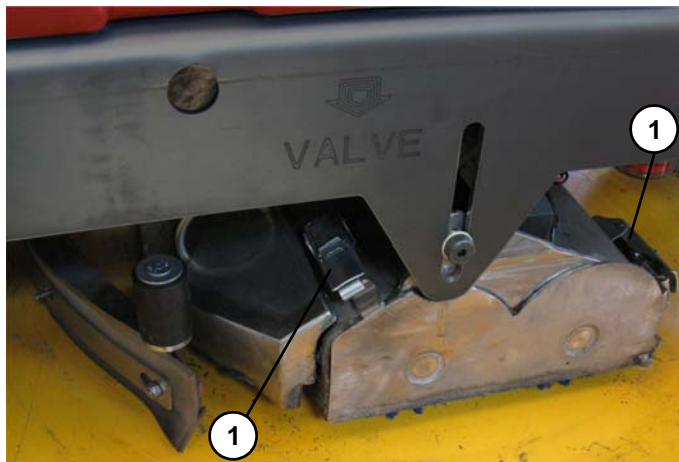

Figure 5-17

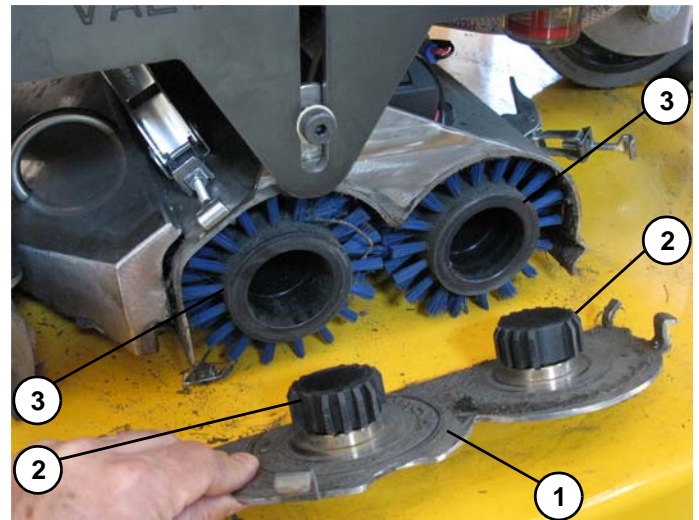

Figure 5-18

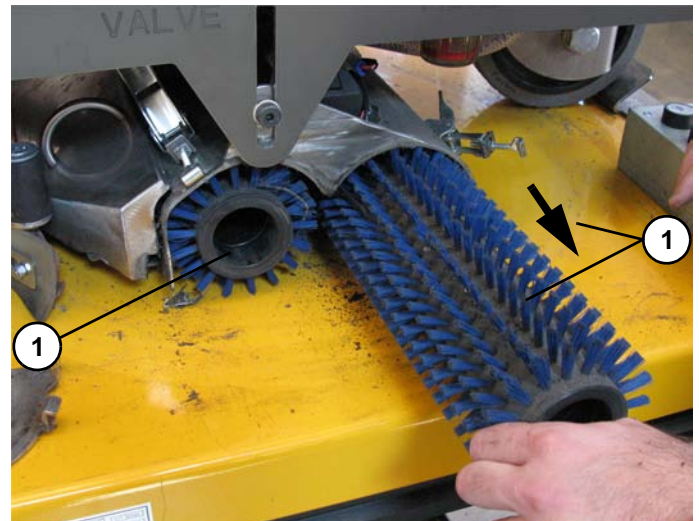

Figure 5-19

Assembly

6. Place the cylindrical brushes in their seat (1, **Figure 5-20**) by ensuring to engage their pentagonal seat (2) in the related hubs (3).
7. Proceed with the assembly by operating in the reverse order with respect to disassembly.

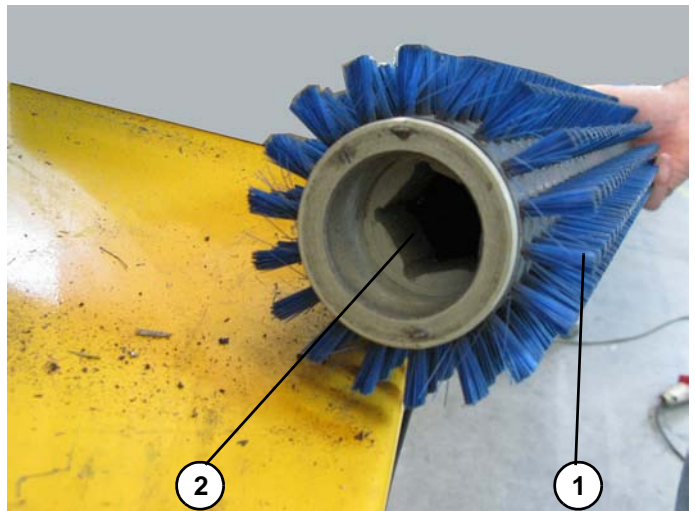
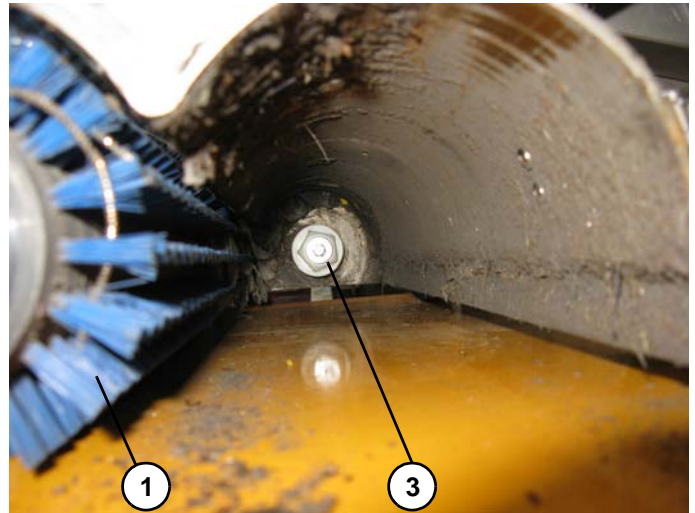

Figure 5-20

CHAPTER 6 SAFETY FUNCTIONS

The wash-and-dry machine is equipped with safety functions described below.

6.1 EMERGENCY STOP BUTTON

It is placed on the control panel and controls, in position (2, **Figure 3-1**); it can be easily accessed by the operator; it must be pressed in situations of immediate necessity to stop every function of the wash-and-dry machine. It is disabled by rotating it clockwise.

6.2 MICROSWITCH OF DRIVER'S SEAT

It is located inside the driver's seat and does not allow any function of the wash-and-dry machine if the operator is not seating on his seat.

CHAPTER 7 TROUBLESHOOTING

PROBLEM	PROBABLE CAUSE	SOLUTION
No light indicators light up on the panel; the motors do not work	Battery connector (5, Figure 3-4) disconnected	Connect it
	Batteries completely flat	Charge them
	The emergency stop button (2, Figure 3-1) remains depressed	Press it
The water recovery drain is insufficient	Dirty squeegee (9, Figure 3-2) or worn out or damaged squeegee rubber blades	Clean the squeegee or turn/replace the rubber blades
	Tank cover not correctly closed or inefficient gasket (8, Figure 4-3)	Close the cover correctly. Clean/replace the gasket
The water recovery drain is inexistent	The water recovery tank is full. Empty it.	Empty it
	Flexible hose (3, Figure 5-13) disconnected from the squeegee.	Connect it
Insufficient flow of the detergent solution (or water for washing) to the disc brush (or cylindrical brushes)	Dirty detergent solution (or water for washing) filter (24, Figure 3-2)	Clean it
	Dirty detergent solution (or water for washing) outlet nozzle	Clean it
	Dirty detergent solution (or water for washing) tanks	Clean it

PROBLEM	PROBABLE CAUSE	SOLUTION
Lack of detergent solution (or water for washing) flow to the disc brush (or cylindrical brushes)	Empty detergent solution (or water for washing) tank	Fill it
	Obstructed detergent solution (or water for washing) (2, Figure 5-7) filter	Clean it
	Obstructed detergent solution (or water for washing) outlet nozzle	Clean it
Deficiency/lack of the washing detergent flow to the disc brush (or cylindrical brushes) (For wash-and-dry machine with MCS optional detergent feeding system)	Too low percentage (%) of detergent flow set	Increase it
	Obstructed detergent feeding system	Clean it
The squeegee leaves trails of dirt on the floor	Debris present below the squeegee rubber blades	Clean the squeegee
	Squeegee rubber blades worn out, chipped, or torn	Turn them/replace them
	The squeegee does not contact correctly	Adjust the height of the squeegee contact wheels
The disc brush (or cylindrical brushes) does not clean	Excessively worn out brushes and do not touch the floor: check. Check the pins (2, Figure 5-4) or the pins (1, Figure 5-6)	Replace the brushes

For further information, contact Minuteman Service Centers, where the Service Manual is available.

CHAPTER 8 SCRAPPING



ATTENTION!

This wash-and-dry machine must not be disposed of with other household waste at the end of its lifecycle.

To avoid possible environmental or health damages caused by an inappropriate waste disposal, the user is advised to separate this product from other types of disposals and recycle it in a responsible manner in order to favour the sustainable reuse of the material resources.

Have the machine scrapped by a qualified dismantler.
Before scrapping the machine, remove the following components:

- Battery
- Brush
- Hoses and plastic parts
- Electric and electronic components

(*): In particular, for scrapping electrical and electronic parts, refer to the local Minuteman Head Office.

