



Electronic Service Manuals

This electronic document is provided as a service to our customers. We do not create the contents of the information contained in this document. Should you have detailed questions pertaining to the information contained in this document, you may contact Michco, or the manufacturer which provided the original information in this electronic deliverable. Michco's only part in this electronic deliverable was the electronic assembly process. By providing this manual on line we are not guaranteeing parts availability.

You may contact Michco through the following methods:

Phone (517) 484-9312 or (800) 331-3339

2011 N. High St. -- Lansing, Michigan -- 48906

Fax: (517) 484-9836

Email: CustServe@Michco.com

Web site: www.Michco.Com

Parts Web site: www.FloorMachineParts.Com

Order Parts on Line at:

www.FloorMachineParts.Com

Directly to Parts & Service:

By Email: **Shop@Michco.com**

By Fax: (517) 702-2041

By Voice: Use numbers above.

Serving the Cleaning Industry Since 1922

Notice: All copyrighted material remains property of original owners, all trademarks are property of respective owners. Manuals are subject to Manufacturer's reproduction limitations. Originals or reproductions were provided by manufacturers through a request. We make no warranty as to the correctness of information provided in this document and you assume all risk. By placing these manuals on line we are not declaring our corporation to be an manufacturer authorized dealer or provider, please check our web site for authorized manufacturers we represent.

Minuteman[®]

SCV 28/32 RIDER SCRUBBER

OPERATION ■

SERVICE ■

PARTS ■

CARE



Minuteman[®]

This manual is furnished with each new **MINUTEMAN SCV™ 28/32**. This provides the necessary operating and preventive maintenance instructions. Operators must read and understand this manual before operating or servicing this machine.

This machine was designed to give you excellent performance and efficiency. For best results and minimal cost, please follow the general guidelines below:

- Operate the machine with reasonable care.
- Follow the manufacturers suggested maintenance instructions as provided in this booklet.
- Use original Minuteman supplied parts.

TECHNICAL SPECIFICATIONS

Model	SCV™ 28/32
Model No.	SCV32C - SBG
Current	60 Amps
Voltage, Batteries	36 volts, 6-6volt
Battery Capacity	312 Ah
Sound Level	75 dB
Dimensions (LxWxH)	67" x 36.25" x 52" (170.18cm x 92.1 cm x 132.1cm)
Gross Weight	1886 lbs (856 kg) with batteries, the operator, and full tank of water.
Working Grade Transport	10% (7°)
Wheel to Floor Pressure	< 55 PSI Front, < 65 PSI Rear

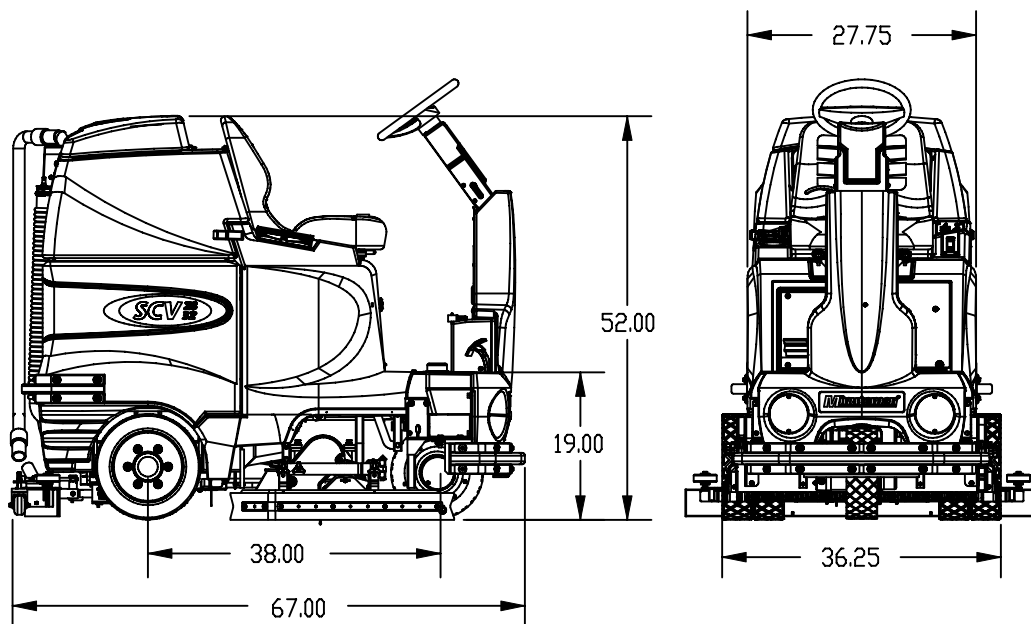

EC Declaration of Conformity

according to Directives 98/37/EC, 89/336/EEC, and 72/23/EEC

We, Minuteman International Incorporated, of 111 South Rohlwing Road Addison Illinois 60101 USA, declare under our sole responsibility that the product SCV 28/32, SC280000CE, SC280001CE, SC320000CE, SC320001CE, SCV28C, SCV28D, SCV32C, SCV32D, SCV28CPLUS, SCV28DPLUS, SCV32CPLUS, SCV32DPLUS to which this declaration relates corresponds to the relevant requirements of the EC Directives 72/23/EEC, 98/37/EC and 89/336/EEC. The following standards were used to determine compliance with the Directives: EN 292, EN 953, EN 55022, EN 60335-1 and EN 60335-2-72.

SOUND		VIBRATION
75 dB Operator	72 dB At 3m	.4 m/s² At Operators Handle
Tests were conducted on 7/15/02 with calibrated sound and vibration equipment under the conditions noted below:		
General Condition: Indoors	Wind: 0 km/hr	
Temperature: 23 ⁰ C	Humidity: 70%	
Barometric Pressure: 29.1		

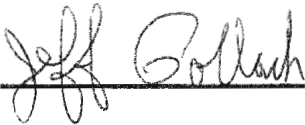

Jeff Pollack, Standards Engineer

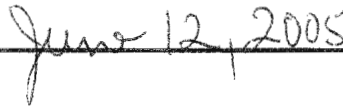

Date

TABLE OF CONTENTS

IMPORTANT SAFETY INSTRUCTIONS	1
FOR SAFETY DURING OPERATION:.....	1
FOR SAFETY WHEN SERVICING or MAINTAINING MACHINE:.....	1
INSPECTION	2
ELECTRICAL	2
BATTERIES	2
OPERATOR RESPONSIBILITY	2
MACHINE OVERVIEW, FRONT	3
MACHINE OVERVIEW, REAR	4
OPERATOR COMPARTMENT	5
CONTROL CONSOLE	6
KEY SWITCH	6
OFF AISLE WAND SWITCH (OPTIONAL).....	6
HEADLIGHT SWITCH (OPTIONAL).....	6
BATTERY GAUGE	6
SOLUTION CONTROL KNOB.....	6
MODE SELECTOR KNOB	6
HORN BUTTON	6
DIRECTIONAL SWITCH	6
OPERATION MODES	7
1. REGULAR SCRUB MODE	7
2. HEAVY SCRUB MODE	7
3. DOUBLE SCRUB MODE.....	7
4. VACUUM ONLY MODE.....	8
5. TRANSPORT MODE	8
6. SOLUTION CONTROL KNOB.....	8
7. BATTERY GAUGE	8
FAULT / DIAGNOSTIC CODES	9
FAULT / DIAGNOSTIC CODES DECAL	9
EMPTY SOLUTION TANK INDICATOR.....	10
LOW BATTERY INDICATOR	10
POWER SAVE MODE	10
OPERATION OF CONTROLS	11
STEERING WHEEL.....	11
ACCELERATOR PEDAL	11
SEAT	11
DIRECTIONAL SWITCH	11
PARKING BRAKE	11
EMERGENCY DISCONNECT BUTTON	12
CIRCUIT BREAKERS.....	12
BATTERY COMPARTMENT	12
BATTERY CONNECTION DIAGRAM.....	13
BATTERIES INSTALLED WITH SPACERS	13
SCRUB DECKS	14
CYLINDRICAL SCRUB DECK	14
DISK SCRUB DECK.....	15

SCRUB DECK INSTALLATION	16
INSTALLATION INSTRUCTIONS	16
IMPORTANT NOTE WHEN INTERCHANGING SCRUB DECKS	17
SIDE SQUEEGEES	18
DISK DECK SIDE SQUEEGEE COMPONENTS	18
CYLINDRICAL DECK SIDE SQUEEGEE COMPONENTS	19
BRUSH CHANGES ON THE CYLINDRICAL DECK	19
REAR SQUEEGEE	20
REAR SQUEEGEE COMPONENTS	20
REAR SQUEEGEE ADJUSTMENT	21
THE SCV RIDER	22
MACHINE OPERATION	23
AFTER USE:	24
MAINTENANCE SCHEDULE	25
LUBRICATING THE MACHINE	25
GENERAL MACHINE TROUBLESHOOTING	26
EXPLODED VIEWS	28
MAIN ASSEMBLY I	28
MAIN ASSEMBLY I BOM	29
MAIN ASSEMBLY II	30
MAIN ASSEMBLY II BOM	31
MAINFRAME ASSEMBLY I.....	32
MAINFRAME ASSEMBLY II.....	33
MAINFRAME ASSEMBLY II BOM.....	34
FRONT DRIVE ASSEMBLY	35
FRONT DRIVE ASSEMBLY BOM	36
STEERING ASSEMBLY	37
STEERING ASSEMBLY BOM.....	38
SOLUTION TANK ASSEMBLY / SEAT ASSEMBLY	39
SOLUTION TANK ASSEMBLY / SEAT ASSEMBLY BOM's	40
ELECTRICAL PANEL.....	41
CONSOLE	42
RECOVERY TANK I	43
RECOVERY TANK I BOM.....	44
RECOVERY TANK II	45
BATTERY BOX ASSEMBLY	46
PUMP ASSEMBLY	47
PUMP ASSEMBLY BOM.....	48
REAR AXLE ASSEMBLY	49
SQUEEGEE MECHANISM ASSEMBLY	50
28" REAR SQUEEGEE ASSEMBLY	51
28" REAR SQUEEGEE ASSEMBLY BOM	52
32" REAR SQUEEGEE ASSEMBLY	53
32" REAR SQUEEGEE ASSEMBLY BOM	54
REAR SQUEEGEE MECHANISM ASSEMBLY.....	55
28" CYLINDRICAL SCRUBDECK	56
28" CYLINDRICAL SCRUBDECK BOM	57

32" CYLINDRICAL SCRUBDECK	58
32" CYLINDRICAL SCRUBDECK BOM	59
28" DISK SCRUBDECK.....	60
28" DISK SCRUBDECK BOM	61
32" DISK SCRUBDECK.....	62
32" DISK SCRUBDECK BOM	63
CYLINDRICAL SCRUBDECK SIDE SQUEEGEE (LEFT SIDE).....	64
CYLINDRICAL SCRUBDECK SIDE SQUEEGEE (RIGHT SIDE)	65
DISK SCRUBDECK SIDE SQUEEGEE (LEFT SIDE).....	66
DISK SCRUBDECK SIDE SQUEEGEE (RIGHT SIDE).....	67
CYLINDRICAL SCRUBDECK AND ROLLER BUMPER MOUNTING	68
SCV28CQP & SCV32CQP BOM's	69
DISK SCRUBDECK AND ROLLER BUMPER MOUNTING	70
SCV28DQP & SCV32DQP BOM's	71
FRONT BUMPER ASSEMBLY.....	72
PLUMBING DIAGRAM	73
WIRING DIAGRAMS	72
TRIO CONNECTIONS.....	74
P3 TRIO CONNECTIONS	75
P2 TRIO CONNECTIONS	76
WIRE COLORS / CODES	77
Minuteman International Made Simple Commercial Limited Warranty	78

IMPORTANT SAFETY INSTRUCTIONS

Operators must read and understand this manual before operating or maintaining this machine. Do not operate this machine in flammable or explosive areas.

This machine is designed solely for scrubbing dirt and dust in an indoor environment. Minuteman does not recommend using this machine in any other capacity.

The following information below may cause a potential hazard to the operator and equipment. Read this manual carefully and be aware when these conditions can exist. Take necessary steps to locate all safety devices on the machine and train the personnel operating the machine. Report any machine damage or faulty operation immediately. **Do not use machine if it is not in proper operating condition.**

FOR SAFETY DURING OPERATION:

Keep hands and feet clear of moving parts while machine is in operation.

Make sure all safety devices are in place and operate properly. All covers, doors and latches must be closed and fastened before use.

During operation, attention should be paid to other persons in the work area and especially if small children are present.

Electric motors and components can cause an explosion when operated near explosive materials or vapor. Do not operate this machine near flammable materials such as solvents, thinners, fuels, grain dust, etc.

Store or park this machine on a level surface only, with the key switch in the off position. To prevent unauthorized use, machine should be stored or parked with the key removed.

This machine is designed for level operation only. **Do not operate on ramps or inclines.**

This machine is not suitable for picking up hazardous dusts.

Use caution when moving this machine into areas that are below freezing temperatures. Any water in the tanks or hoses can cause damage to the machine.

FOR SAFETY WHEN SERVICING or MAINTAINING MACHINE:

Stop on level surface and turn off machine.

Disconnect the power to the machine by pressing the Red Emergency Disconnect Button when charging batteries or during installation or removal of brushes.

Avoid moving parts. Do not wear loose jackets, shirts, or sleeves when working on machine.

Avoid contact with battery acid. Battery acid can cause burns. When working on or around batteries, wear protective clothing and safety glasses. Remove metal jewelry. Do not lay tools or metal objects on top of batteries.

Charging batteries generates explosive gasses. **Do not charge batteries when open flames or sparks are present. Do not smoke.** Make sure the charger is turned off before disconnecting it from the machine. Charge the batteries in a well-ventilated area with the battery cover removed completely.

Do not clean machine with a pressure washer.

Authorized personnel must perform repairs and maintenance. Use Minuteman supplied replacement parts.

SAVE THESE INSTRUCTIONS

INSPECTION

Carefully unpack and inspect your SCV Rider Scrubber for shipping damage. Follow unpacking instructions on shipping pallet. Each unit has been tested and thoroughly inspected before shipment. Any damage is the responsibility of the delivery carrier who should be notified immediately.

ELECTRICAL

This machine is battery operated and designed to operate on 36 Volts DC (6) 6-volt batteries.

BATTERIES

The recommended batteries are rated 312Ah (Minuteman P.N. 956745).

We do not recommend mixing Amp Hour capacities. Any alternate battery sets can be used if they are of equal physical size and capacity. See "Battery Compartment" for service and installation.

OPERATOR RESPONSIBILITY

Read this manual carefully before operating this machine.

The operator is responsible for taking care of the daily maintenance and check ups of the machine to keep it in good working condition. The operator must inform the service mechanic or supervisor when scheduled maintenance is required as stated in the *MAINTENANCE* section of this manual.

Before starting, familiarize yourself with the machine and its controls (see "Machine Overview, Front", "Machine Overview, Rear", "Operator Compartment", & "Control Console" diagrams).

MACHINE OVERVIEW, FRONT

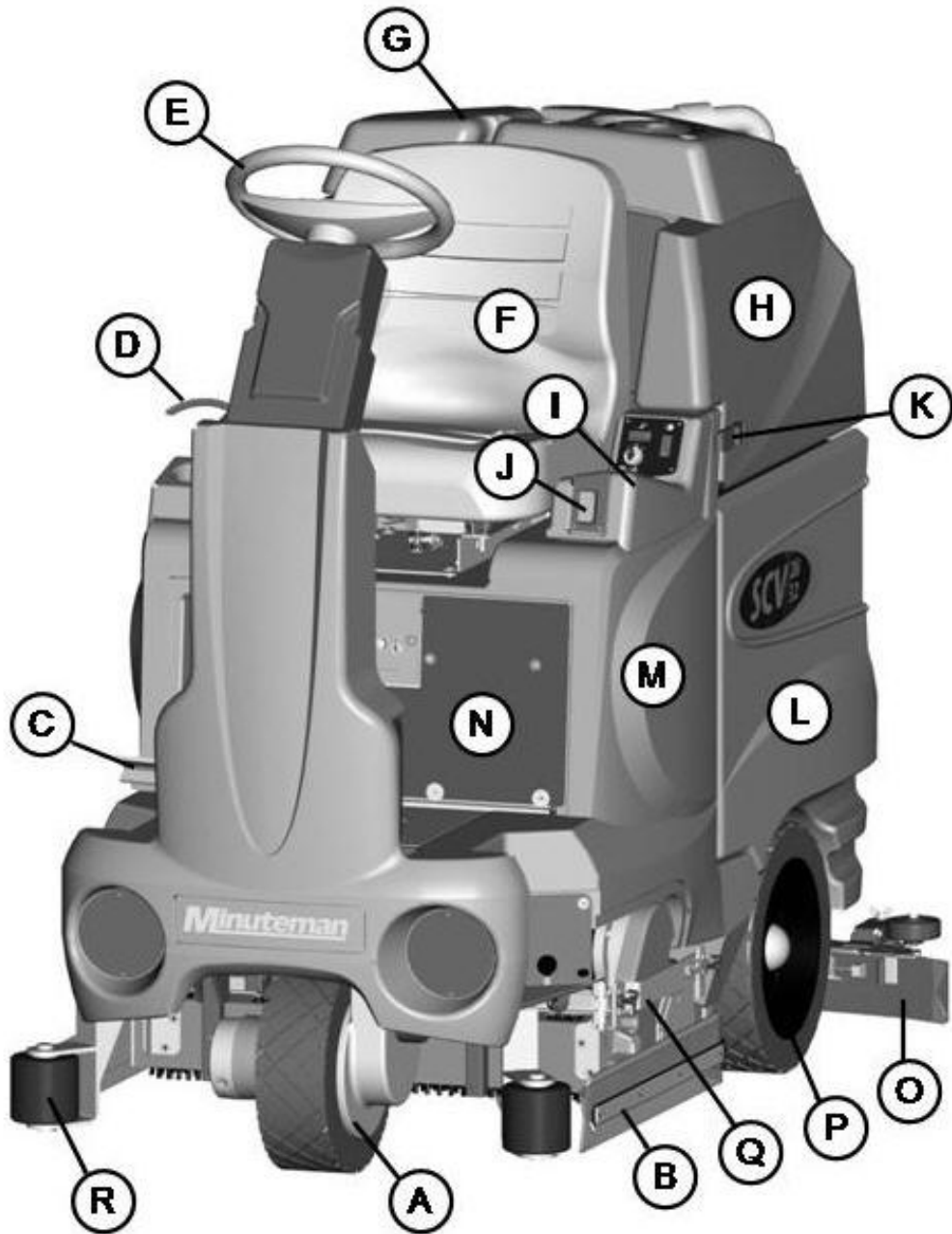

A	Front Drive Wheel	J	Directional Switch
B	Side Squeegee	K	Safety Latch
C	Accelerator Pedal	L	Battery Compartment
D	Steering Tilt Lever	M	Solution Tank
E	Steering Wheel	N	Electrical Panel
F	Operator's Seat	O	Rear Squeegee
G	Recovery Tank Lid	P	Rear Wheel
H	Recovery Tank	Q	Scrubdeck
I	Control Console	R	Roller Bumper

MACHINE OVERVIEW, REAR

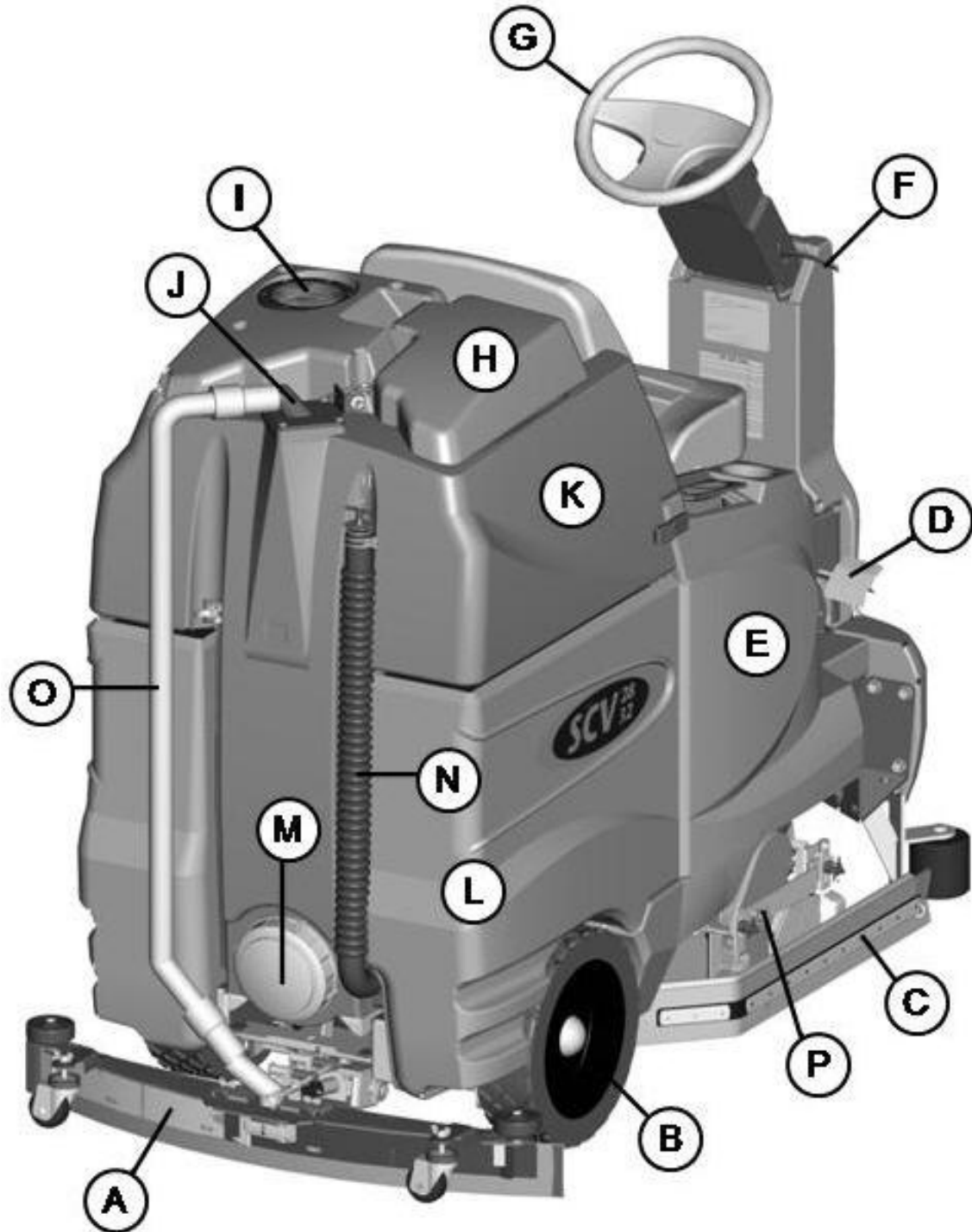

A	Rear Squeegee	I	Vacuum Filter Access
B	Rear Wheel	J	Vac Inlet Assembly
C	Side Squeegee	K	Recovery Tank
D	Accelerator Pedal	L	Battery Compartment
E	Solution Tank	M	Clean-Out Cap
F	Steering Tilt Lever	N	Recovery Drain Hose
G	Steering Wheel	O	Recovery Hose
H	Recovery Tank Lid	P	Scrubdeck

OPERATOR COMPARTMENT

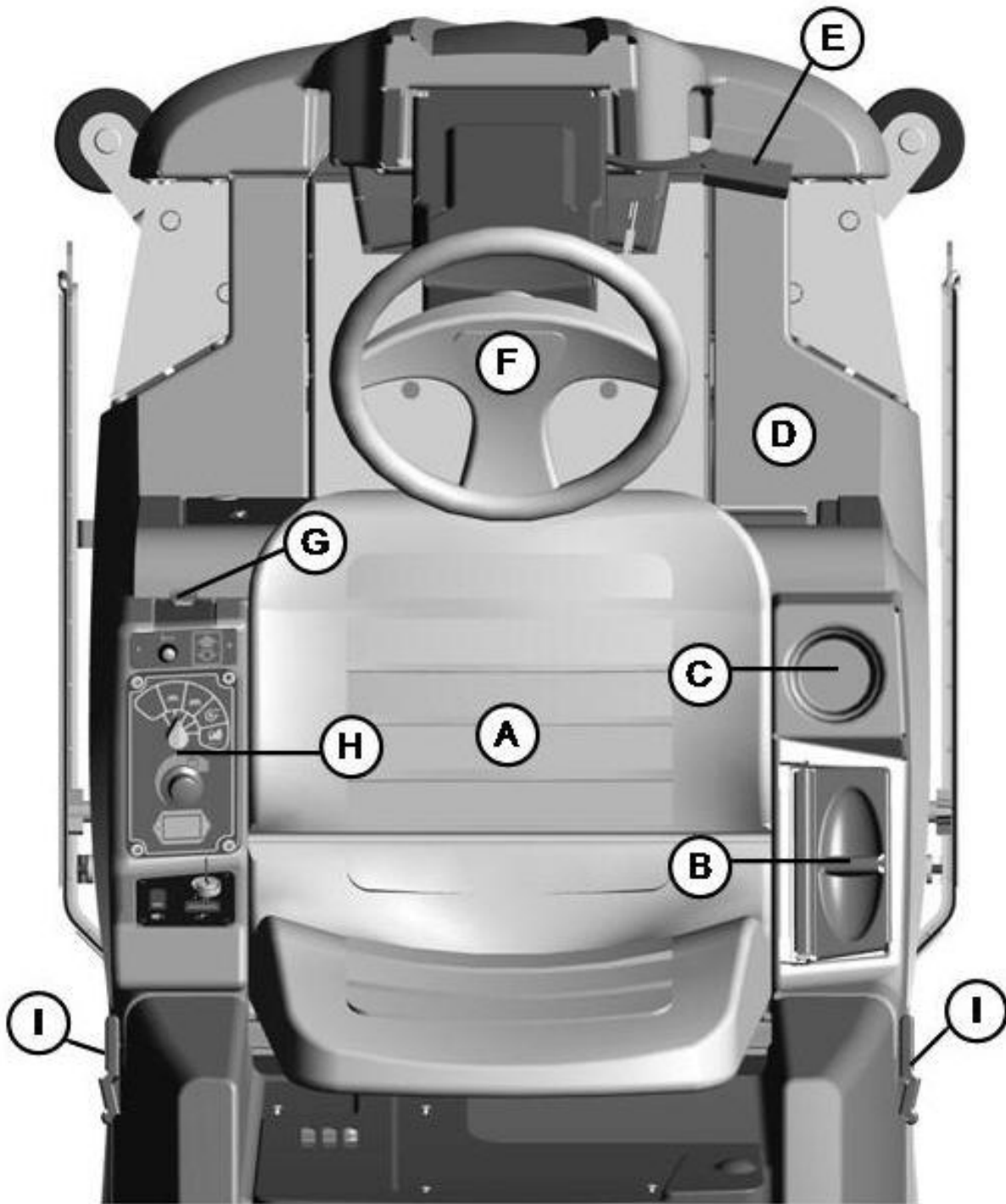

A	Operator's Seat	F	Steering Wheel
B	Solution Tank Lid	G	Directional Switch
C	Cup Holder	H	Control Panel
D	Solution Tank	I	Safety Latch
E	Accelerator Pedal		

CONTROL CONSOLE

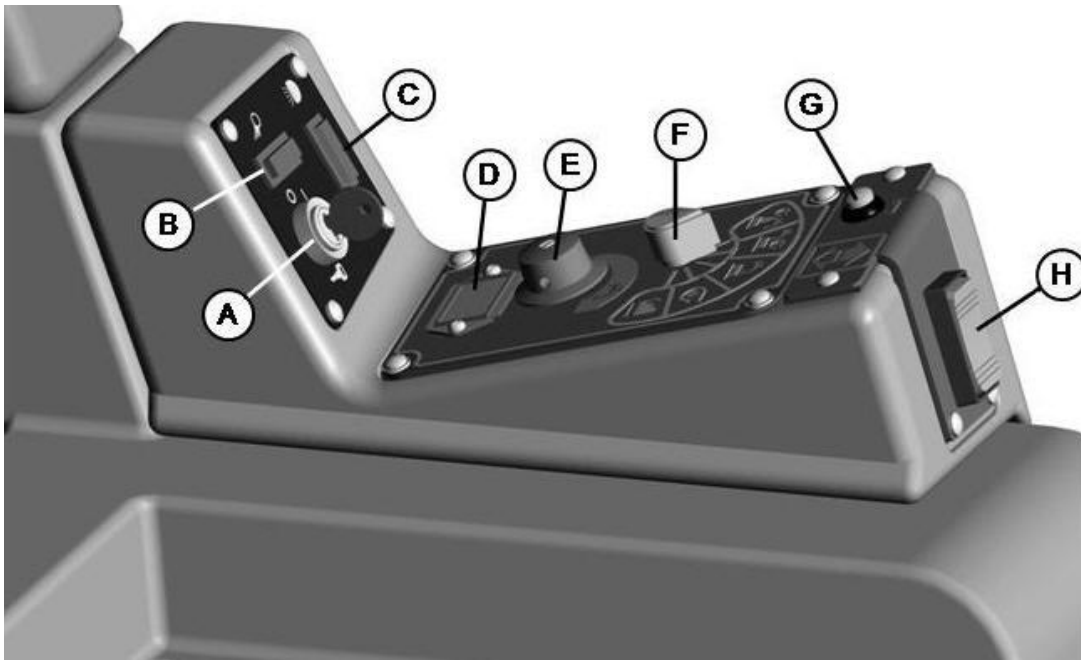

For operator ergonomics, the control console houses all the primary function controls in a central area. The key switch and optional headlight and off-aisle wand switches are clustered in the back portion of the console. The directional switch (forward/reverse) is located at the front of the console for easy fingertip operation. The horn button, function selectors, and battery gauge are located in the central part of the console.

KEY SWITCH (A) – Controls the machine’s power (ON/OFF) with a key for safety. All operational settings are retained even when the power is turned off and on. This also serves as a reset switch when errors or faults occur.

OFF AISLE WAND SWITCH (OPTIONAL) (B) – ON/OFF control for the water supply to the wand and vacuum motor for the optional Off-Aisle Wand.

HEADLIGHT SWITCH (OPTIONAL) (C) – ON/OFF control for the optional headlights.

BATTERY GAUGE (D) - Displays the level of charge remaining in the machine’s batteries. The gauge consists of 10 LEDs. (3 Green, 4 Amber, 3 Red) If the battery life is low, the battery gauge bar icon will be flashing to inform the operator that the machine is almost out of power. Once this signal is displayed, all functions will shut off, including transport mode. The operator must then *turn the key switch OFF and then ON* to reset the machine. The machine will then have only a few minutes left of reserve power to briefly use *Vacuum Only mode* to pick up any remaining solution on the floor and *Transport mode* to return to the charging station. This gauge will also display a fault code if the system has an error. This code is represented by a specific number of flashing LEDs. See *Fault/Diagnostic Codes for specific code information*.

SOLUTION CONTROL KNOB (E) – Adjusts the amount of solution being dispensed to the floor while in one of the scrub modes. Turn the knob clockwise to increase the amount of solution being dispensed. The amount of solution applied is variable to a maximum of 1 GPM.

MODE SELECTOR KNOB (F) – This knob is used to select the desired operation mode of the machine. See *Operation Modes for information about each mode*.

HORN BUTTON (G) – Depressing this button will activate the machine’s horn.

DIRECTIONAL SWITCH (H) – Flipping this switch to the down position will set the machine to move forward. Flipping it to the up position sets the machine to move in reverse.

OPERATION MODES

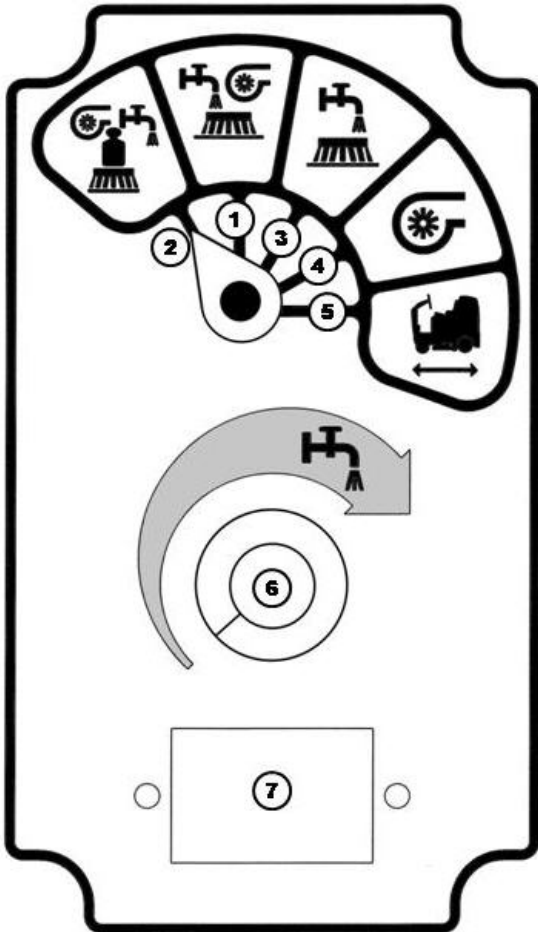

1. REGULAR SCRUB MODE

When the machine is running in this mode, the machine will perform all operations. This mode can be used for day-to-day tasks under normal conditions. When the operator sets the *directional switch* to *forward* and activates the *accelerator pedal*, the solution pump will turn on, the brushes will turn on and be lowered to the floor, as well as the rear squeegee. While operating in this mode, the solution will be dispersed into the brushes, which will scrub the floor allowing the chemical in the solution to break down the dirt on the floor. As the machine continues to move forward, the rear squeegee and vacuum system will recover the dirt and dispensed solution. If the operator stops moving, the machine will automatically raise the scrub deck and turn off the brushes. If the *directional switch* is changed to reverse the machine will continue to operate normally, only the rear squeegee will raise up.

2. HEAVY SCRUB MODE

This mode is similar to *Regular Scrub*. The machine will continue to operate the same as if it was in *Regular Scrub Mode*, only this mode applies more solution and brush pressure is increased. This mode is used for high traffic areas and areas that have been heavily soiled, but do not require time for the solution to soak.

3. DOUBLE SCRUB MODE

When the machine is running in this mode, the machine will perform all operations except dirty solution recovery. This mode can be used if the floor is heavily soiled and the chemical will need additional time to emulsify grease and oils that are on the floor. When the operator sets the *directional switch* to either the *forward* or *reverse* position and activates the *accelerator pedal*, the solution pump will turn on, the brushes will turn on and be lowered to the floor. While operating in this mode, the solution will be dispersed into the brushes, which will scrub the floor allowing the chemical in the solution to break down the dirt on the floor. As the machine continues to move forward or back, the rear squeegee and vacuum system are not on, which allows the solution to stay on the floor emulsifying the grease and oil. If the operator stops moving in either direction, the machine will automatically raise the scrub deck and turn off the brushes.

After double scrubbing, the operator should use *the vacuum only mode* to recover the dirty solution water from the floor.

4. VACUUM ONLY MODE

When the machine is running in this mode, the machine will only lower the rear squeegee and turn on the vacuum system to recover the dirty solution from the floor. This mode is usually chosen after double scrubbing to recover the dirty solution but it can also be used to pick up spills. When the operator sets the *directional switch* to *forward*, the rear squeegee will be lowered to the floor as the vacuum turns on, pulling the dirty solution water from the rear squeegee into the recovery tank. If the operator stops moving forward and sets the directional switch to *reverse*, the rear squeegee will retract (protecting it from damage) and the vacuum motor will turn off after a few seconds. If the operator quits moving in either direction, the machine will automatically raise the squeegee and turn off the vacuum motor after a few seconds.

5. TRANSPORT MODE

When the machine is set in this mode, none of the cleaning functions of the machine will operate. This mode is only used to transport the machine from one location to another at a faster rate of speed.

6. SOLUTION CONTROL KNOB

This control will adjust the amount of solution that is being dispersed to the floor while in one of the scrub modes. Adjust the control clockwise to increase the amount of solution being dispersed. The amount of solution applied is variable to a maximum of 1 GPM.

7. BATTERY GAUGE

This gauge displays the level of charge remaining in the machine's batteries. The gauge consists of 10 LEDs. (3 Green, 4 Amber, 3 Red) If the battery life is low, the battery gauge bar icon will be flashing to inform the operator that the machine is almost out of power. Once this signal is displayed, all functions will shut off, including transport mode. The operator must then *turn the key switch OFF and then ON* to reset the machine. The machine will then have only a few minutes left of reserve power to briefly use *Vacuum Only mode* to pick up any remaining solution on the floor and *Transport mode* to return to the charging station. This gauge will also display a fault code if the system has an error. This code is represented by a specific number of flashing LEDs. See *Fault/Diagnostic Codes for specific code information*.

FAULT / DIAGNOSTIC CODES

When an error or fault occurs within the machine, a fault code will appear on the battery gauge represented by a specific number of flashing LEDs. The figure below shows a listing of the different codes.

FAULT / DIAGNOSTIC CODES DECAL

Diagnostic Codes	
<i>The number of flashing bars on the battery gauge represent fault codes as indicated below:</i>	
Low battery voltage <i>Check condition of battery and connections</i>	1
Traction Motor fault <i>Check all connections between the motor and control system</i>	2
Brush Motor fault <i>Check all connections between the motor and control system</i>	3
Actuator Fault <i>Reset Key</i>	4
Vacuum Motor fault <i>Check all connections between the motor and the control system</i>	5
Off-Aisle Wand Activated <i>Check Off-aisle wand switch position</i>	6
Throttle fault <i>May indicate incorrectly wired or faulty potentiometer</i>	7
Control system fault <i>Check all connections are secure</i>	8
Solution Tank Empty <i>Tank Needs To Be Filled</i>	9
High battery voltage <i>Check condition of battery and connections</i>	10
Throttle Displaced on start up <i>Restart keyswitch-throttle was activated prior to ignition</i>	Ripple
Please refer to manual for detailed trouble shooting information	
715908	

EMPTY SOLUTION TANK INDICATOR

Once the solution tank has become empty, the battery gauge will blink a solid 9 LEDs at a constant interval to alert the operator that the solution tank needs to be filled.



LOW BATTERY INDICATOR

If the battery life is low, the battery gauge bar icon will be flashing to inform the operator that the machine is almost out of power. Once this signal is displayed, all functions will shut off, including transport mode. The operator must then *turn the key switch OFF and then ON* to reset the machine. The machine will then have only a few minutes left of reserve power to briefly use *Vacuum Only mode* to pick up any remaining solution on the floor and *Transport mode* to return to the charging station.

POWER SAVE MODE

The SCV is equipped with a power save feature to conserve battery power. If the key switch power is left ON and none of the controls are activated for a period of fifteen minutes, the SCV automatically goes into "power down mode" and turns OFF the power to conserve your batteries in case the operator forgets to turn the key switch off or leaves the machine unattended.

OPERATION OF CONTROLS

STEERING WHEEL

The steering wheel is adjustable for operator comfort by pulling the *tilt-steering lever* up and positioning the steering wheel up or down (there are three possible positions). Pulling on the *tilt-steering lever* and positioning the steering column in an upright position provides the operator with more room when climbing up and down the machine.



ACCELERATOR PEDAL

Located on the right side of the operator compartment on the floor is the accelerator pedal. This pedal controls the propelling speed of the machine. The farther the pedal is pushed down the faster the machine will travel. As discussed earlier, the directional switch governs the direction of travel the machine will take. Switching the directional switch with the pedal depressed will make your machine change directions (a very slight delay may occur before the direction of travel changes when switching directions on the fly). The accelerator pedal is interlocked with the seat switch, making machine propulsion not possible without the operator sitting on the seat. The accelerator pedal is also linked to the machine's *dynamic braking system*. During operation, when the accelerator pedal is released, the dynamic braking system will automatically halt the movement of the machine without need for an additional brake pedal.

SEAT

The ergonomically designed seat is located on top of the solution tank. There is a lever under the seat that allows the operator to adjust the seat forward or backward for operator comfort. There is an interlock switch located inside the seat. This makes it impossible to engage the traction drive circuitry without the operator on the seat. If the operator were to fall off the machine, the traction drive circuitry would turn off.

DIRECTIONAL SWITCH

Located on the lower front of the control console, this switch controls the direction in which the SCV will move when the *accelerator pedal* is activated. Flipping this switch to the down position will set the machine to move forward. Flipping it to the up position sets the machine to move in reverse.

PARKING BRAKE

This machine is equipped with an *Electro-magnetic brake* built-in on the traction drive motor. When the machine's power is turned off (using either the key or the emergency button), the *E-mag* brake is activated and the traction motor is prevented from moving.

EMERGENCY DISCONNECT BUTTON

This button is located in the middle of the electrical panel that is directly underneath the operator's seat. When the *red* emergency button is pressed, power will be turned off. Use this button in case of a machine emergency. The red knob needs to be raised in order to run the machine. To reactivate, turn the knob as shown by the arrows on the switch and the button will pop up. *All operational settings are retained even when the power is turned off and on.*



CIRCUIT BREAKERS

The circuit breakers are located next to the emergency disconnect button. The **6-amp breaker** (indicated by black arrow) protects all auxiliary circuits on the machine. The **100-amp breaker** (indicated by white arrow) protects the main system circuit (TRIO controller). Each main component is individually protected with an internal breaker built-in the controller. (See fault code table) and can be reset by turning the key switch off a few seconds and then on again. The 100 amp circuit breaker can also be used as a main power disconnect, this should be used only in case of emergency. When tripped the breaker removes power from the main controller and all auxiliary power circuits.

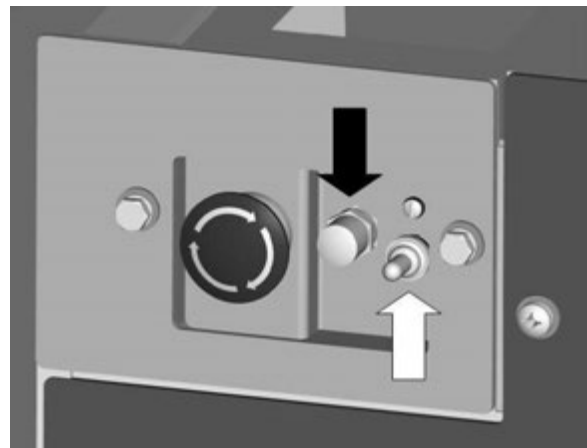

BATTERY COMPARTMENT

The battery compartment is located on the rear of the machine under the recovery tank. Unlatching the two safety latches on the side of the machine enables the operator to tilt the recovery tank and access the batteries for servicing and maintenance (make sure recovery tank has been drained before tilting). The battery compartment contains six, 6-volt batteries connected in series. Connect the batteries according to the battery connection diagram (*see diagram*). The recommended batteries are 275Ah (Minuteman P.N. 956740). The two batteries positioned in the center are offset and held in position by two steel spacers. These spacers keep the batteries from sliding inside the battery compartment during machine use and prevent undesired stresses in the battery cables. Be sure to replace these spacers whenever reinstalling batteries.

BATTERY CONNECTION DIAGRAM - SBG

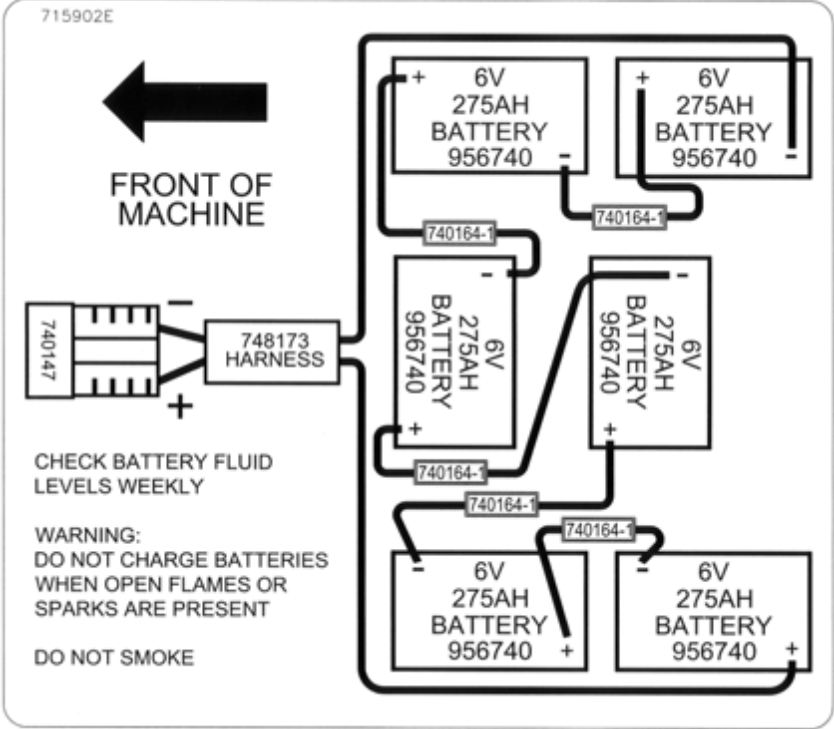

BATTERIES INSTALLED WITH SPACERS

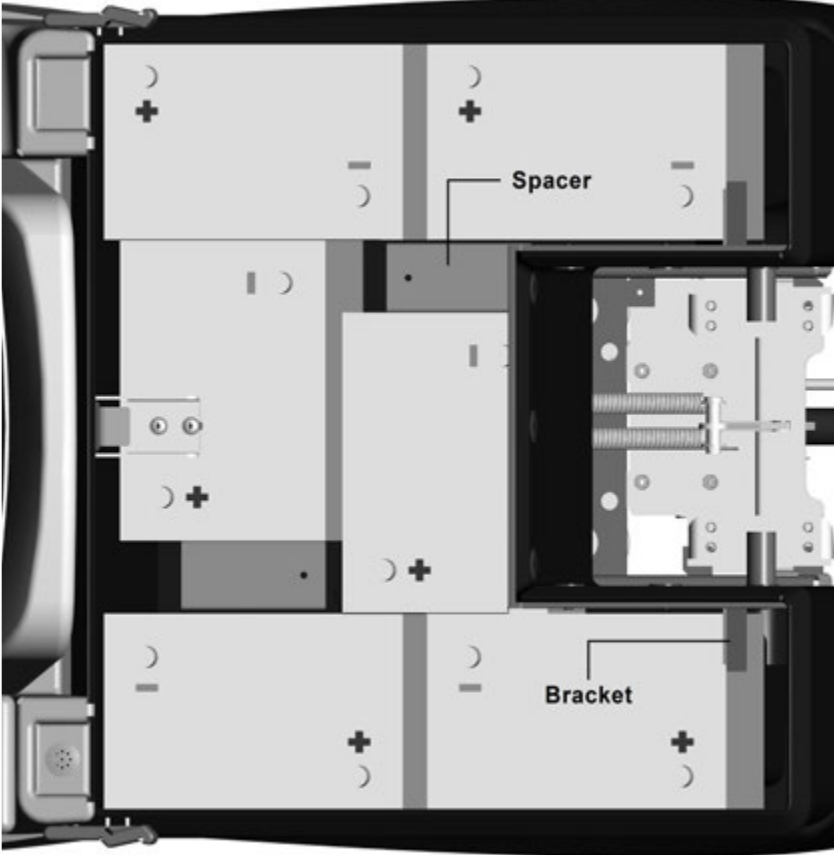

SCRUB DECKS

Minuteman offers two deck types (*Cylindrical and Disc*) to fit your specific needs. The SCV design is very dynamic wherein the decks are interchangeable in a matter of minutes whenever necessary (removal of four bolts, one hose, and one electrical connection). The *cylindrical brush deck* has five built-in spray jets to uniformly dispense cleaning solution on the floor and a wet sweeping debris tray to collect loose objects on the floor. The *disc brush deck* dispenses cleaning solution through the two center hubs and the solution is contained within the bristle area for efficient agitation of cleaning solution to the floor and channeled to the rear of the machine. The disc brushes are also easily removed and installed by easily removing the side deck covers and releasing the quick release clamp. Another nice feature that these scrub decks have is the ability to have uniform brush pressure applied to the floor at all times. Since the scrub deck brush pressure is computer controlled, it will automatically adjust and compensate to uneven contours on the floor while maintaining brush pressure.

CYLINDRICAL SCRUB DECK

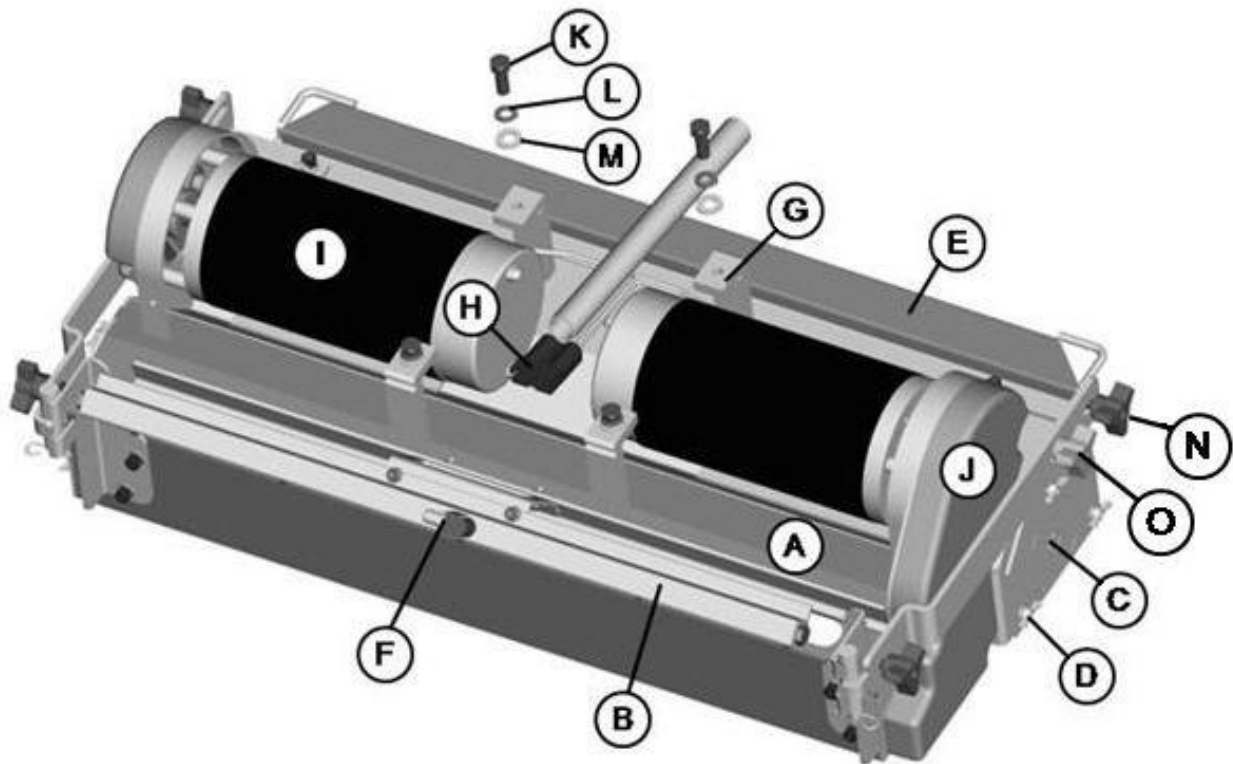

A	Main Housing	I	Brush Motor (2)
B	Spray Bar w/ Sprayjets	J	Pulley Cover (2)
C	Access Door (2)	K	Bolt (4)
D	Access Door Wingnut (6)	L	Helical Lock Washer (4)
E	Debris Box	M	Flat Washer (4)
F	Water Supply Hose Connection	N	Black Squeegee Adj. Knob (4)
G	Mounting Bracket	O	Yellow Brush Access Knob (2)
H	Power Connector		

DISK SCRUB DECK

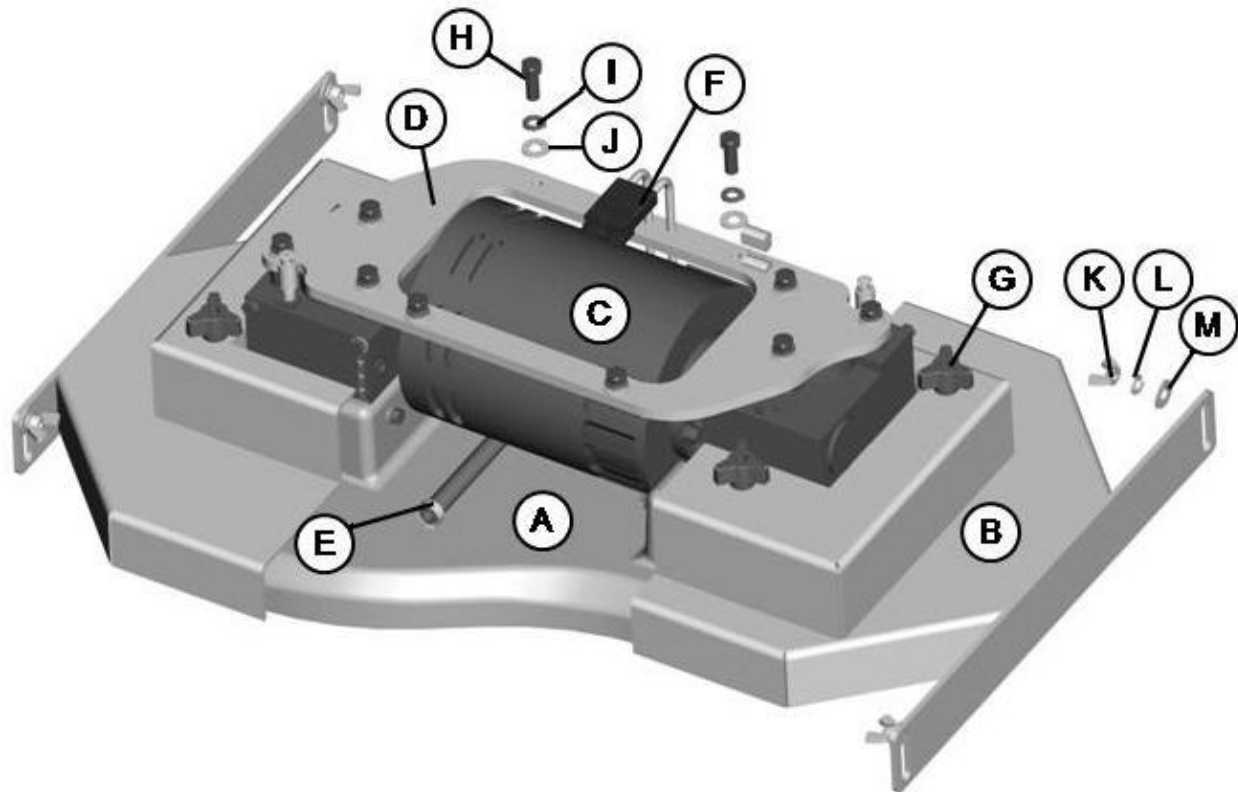

A	Center Deck Cover	H	Bolt (4)
B	Side Deck Cover (2)	I	Helical Lock Washer (4)
C	Brush Motor	J	Flat Washer (4)
D	Mounting Plate	K	Wing Nut for Squeegee Adj. (4)
E	Solution Feed Hose	L	Helical Lock Washer for Squeegee Adj. (4)
F	Power Connector	M	Flat Washer for Squeegee Adj. (4)
G	Three Sided Knob (4)		

SCRUB DECK INSTALLATION

When installing a cylindrical deck to a machine:

1. Install brushes **after** the deck has been mounted to avoid flat spots on the brushes.
2. Use a piece of cardboard underneath the deck to prevent scratches to the painted surface when sliding the deck under the machine.
3. Make sure the scrub deck is oriented correctly with the spray jets towards the front of the machine.

When installing a disc scrub deck to a machine:

1. Install brushes on the scrub deck; this aids the installer in sliding the deck assembly into position.
2. Make sure the scrub deck is oriented correctly with the solution hose tee fitting towards the front of the machine.

INSTALLATION INSTRUCTIONS

1. Park the machine on a flat or level surface.
2. Turn the key switch to the ON position and select the transport mode with mode selector knob.
3. Slide the scrub deck assembly underneath the machine (follow instructions as described above)
4. Position the scrub deck to align the mounting brackets with the mounting lugs on the lift linkage.
5. Lower the lift linkage to the floor by pressing the manual override switch for five seconds. (see figure)
6. Lower the lift linkage mounting lugs until they barely touch the scrub deck mounting brackets.
7. Fasten with the four (4) 711242 bolts, 711515 flat washer and 711546 lock washer.
8. **For cylindrical scrub deck only:**
 - a. Remove the Yellow 3 sided knob on the side squeegee assembly and swing out the side squeegee to reveal the access door.
 - b. Remove the two access doors (one on each end) by removing the three wing nuts on each door.
 - c. Install the brushes by sliding them through the access opening. (see figure for correct orientation.)

Manual Override Switch, located behind electrical panel.

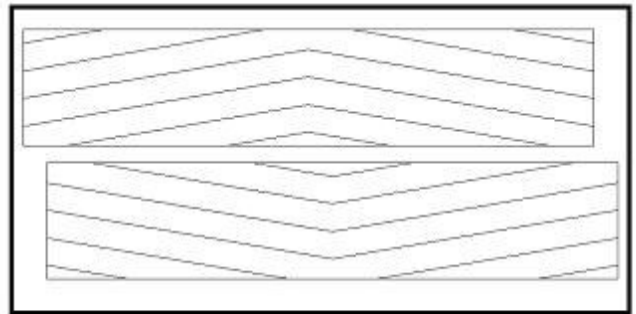

Cylindrical scrub brushes must be installed with the chevron pattern pointing away from each other for best water and debris pick up.

- d. Align the notches on the brush with the drive pins on the hub.
- e. Push the brush all the way in until it bottoms out.
- f. Insert the access door hub into the other end of the brush.
- g. Reinstall the wing nuts and yellow 3 sided knobs and tighten.

IMPORTANT NOTE WHEN INTERCHANGING SCRUB DECKS

As previously mentioned, the scrub deck brush pressure is computer controlled. However, when interchanging the two types of decks, an additional step must be taken to ensure that the controller correctly compensates the pressure for the type of deck that is currently installed.

Inside the main electrical box, beneath the seat there is an Orange/Violet jumper wire (shown disconnected in Figure 1) that may or may not be connected to the terminal block, depending on the type of scrub deck that was originally ordered with the machine. When using the **Disk Scrub Deck**, the wire is **disconnected**. When using the **Cylindrical Scrub Deck**, the wire is connected to the terminal block located in the electrical box, beneath the TRIO Controller. This terminal block is divided into five sections, each separated by a divider. The four leftmost sections contain one column each of spade terminals. The section on the right contains two columns of spade terminals (**this section also contains four Red/Black wires, not shown in Figure 2 for clarity**). The Orange/Violet wire must be connected to a spade terminal in the section with two columns when using the Cylindrical Scrub Deck **ONLY!**

When switching from the Cylindrical Scrub Deck to the Disk Scrub Deck, **be sure to disconnect** the Orange/Violet wire. When switching from the Disk Scrub Deck to the Cylindrical Scrub Deck, **connect** the Orange/Violet wire to any available spade terminal in the section that contains two columns (shown in Figure 2) and the Red/Black wires.



Figure 1
Jumper wire disconnected

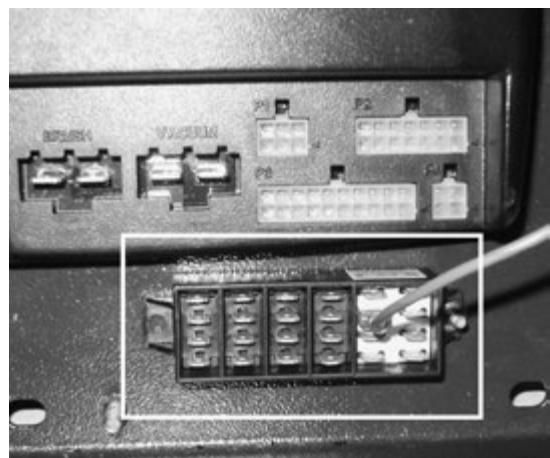

Figure 2
Jumper wire connected to terminal block

SIDE SQUEEGEES

The side squeegees (left and right) are attached to the scrub decks. These items channel the dirty solution to the rear squeegee, helping contain the water within the machine's cleaning path. These squeegees are raised when the scrub deck is in the raised position.

The side squeegees are pre-adjusted at the factory. Adjustments may be required when replacing worn blades or to achieve optimum performance for different floors and conditions.

To adjust the side squeegees, simply loosen the mounting hardware (Two wing nuts for Disk Scrub Deck, two black three-sided knobs for Cylindrical Scrub Deck). Lower the scrub deck by switching to a scrubbing mode and when the brushes start up, turn off the key switch. At this point the side squeegees should be resting vertically (no deflection) on the floor. Press down on the side squeegee bracket assembly from each end while making sure that the blade is uniformly deflected in a 45 degree angle along its whole length. Tighten the wing nuts (item A). Turn the steering wheel all the way to the left or right and start pushing the machine to the side to inspect the blade deflection and wiping action. Repeat the steps above until a satisfactory result is obtained.

DISK DECK SIDE SQUEEGEE COMPONENTS

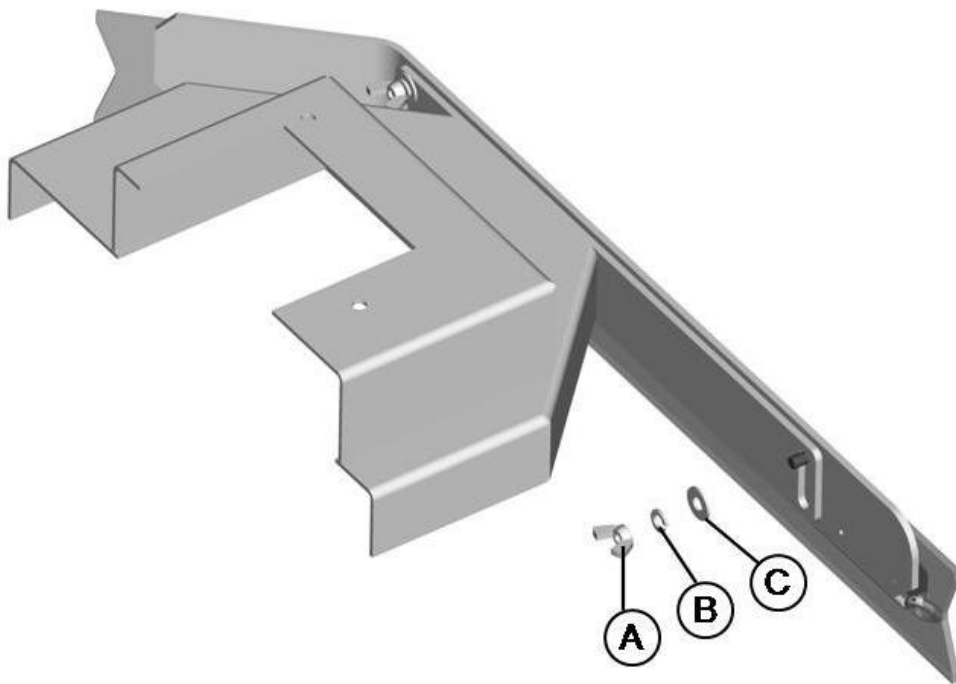

A	Wing Nut for Squeegee Adjustment (2)
B	Helical Lock Washer for Squeegee Adjustment (2)
C	Flat Washer for Squeegee Adjustment (2)

CYLINDRICAL DECK SIDE SQUEEGEE COMPONENTS

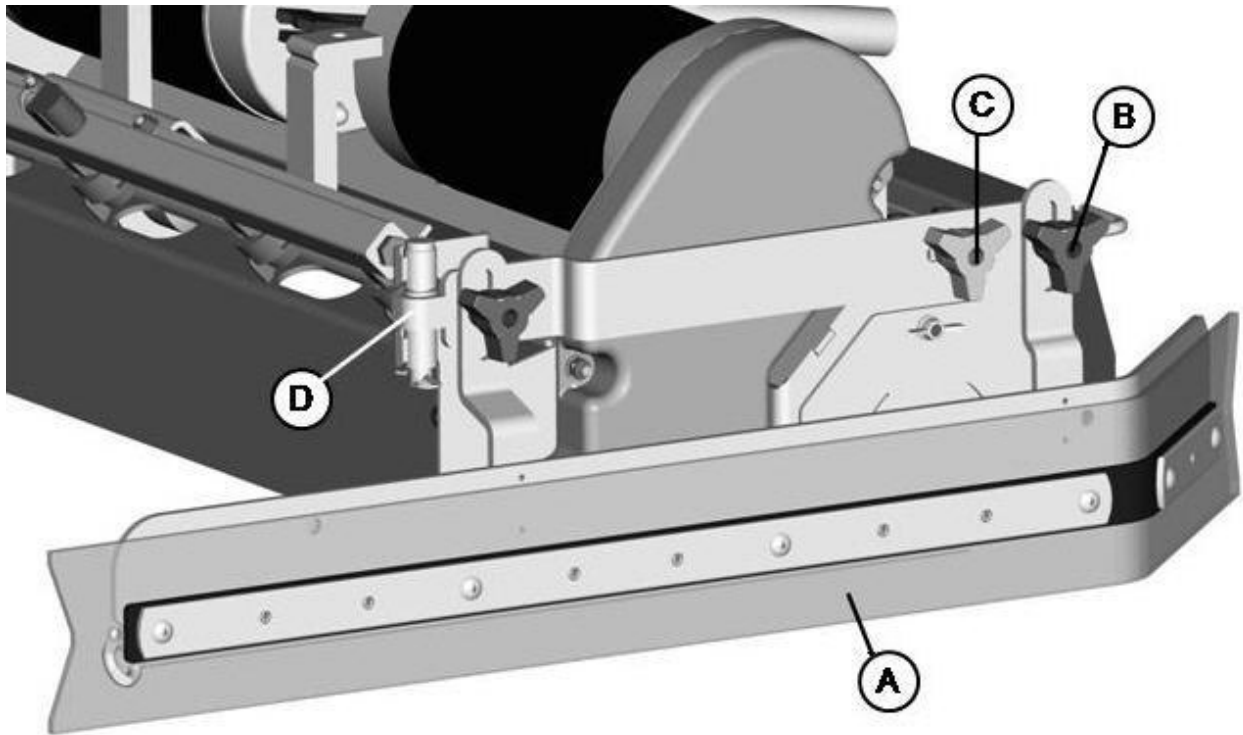

A	Side Squeegee Blade
B	Black Squeegee Adjustment Knob (2)
C	Yellow Brush Access Knob
D	Side Squeegee Hinge

BRUSH CHANGES ON THE CYLINDRICAL DECK

In order to change the brushes on the cylindrical deck the side squeegee must be moved in order to access the brush doors. The cylindrical deck was designed so one can change the brushes without having to realign the side squeegees. This is accomplished by removing the yellow three-sided knob (Item C) and swinging the squeegee along the hinge bracket (Item D) located at the front of the deck, gaining access to the brushes. Once completed inserting new brushes, replace the brush doors and swing the squeegee back into place, tightening down the knob (Item C).

In order to remove or adjust the alignment of the side squeegees on the cylindrical deck, remove the black three-sided knobs (Item B) and follow the instructions on the previous page.

REAR SQUEEGEE

The rear squeegee is the main element that acts as the conduit that transfers the spent solution into the recovery tank. A daily maintenance check of this component is essential to have optimum machine performance. The rear squeegee assembly is equipped with a universal front blade that allows the operator the option to use a slotted and a non-slotted side for specific applications. Each blade configuration has two usable edges. The rear blade however has four usable edges.

The squeegee is pre-adjusted at the factory. Adjustments may be required to get optimum performance for different floors and conditions.

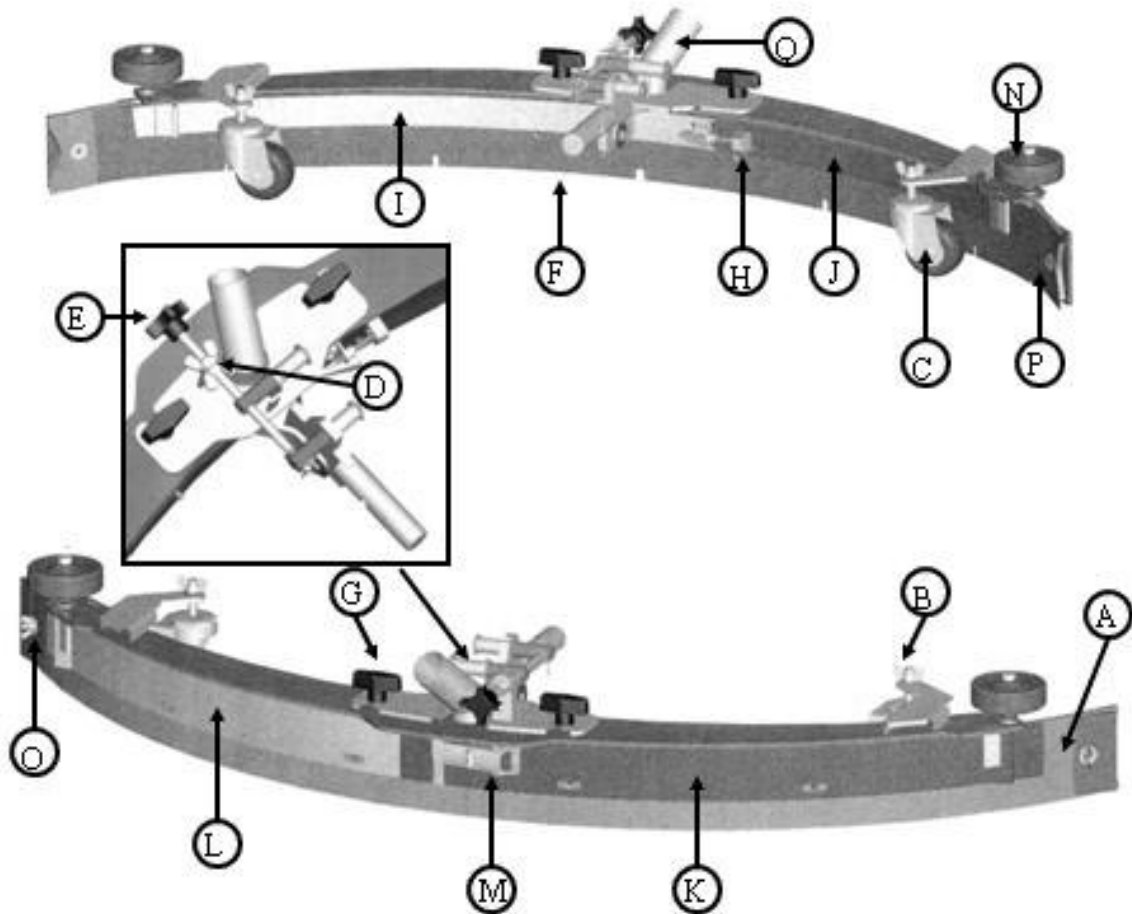

REAR SQUEEGEE COMPONENTS

- | | |
|-------------------------------|----------------------------|
| A. Rear squeegee blade | J. Front strap (short) |
| B. Wing jam nut (2) | K. Rear strap (latch side) |
| C. Swivel Caster (2) | L. Rear strap (catch side) |
| D. Wing Jam Nut | M. Latch |
| E. Turnbuckle Adjustment Knob | N. Guide wheels (2) |
| F. Front squeegee blade | O. Nylon wing bolt (2) |
| G. Wing bolt (2) | P. Nylon bolt (2) |
| H. Toggle clamp | Q. Recovery hose intake |
| I. Front strap (long) | |

REAR SQUEEGEE ADJUSTMENT

1. Ensure that the scrubber is on a relatively flat surface. Turn on the key switch and select the **Vacuum only** mode. This lowers the squeegee to the floor and turns the vacuum motor on.
2. Move the scrubber one or two feet forward slowly while someone behind the machine checks the rear squeegee blade (item **A**) for uniform deflection to the floor.
3. If uneven deflection or lay is evident, minor adjustments may be necessary to avoid streaking and uneven wear on the blade.
4. To correct this, loosen the wing jam nut (item **B**) in order to adjust the caster height. If the squeegee blade is deflecting too much, the casters (item **D**) need to be lowered to control the down pressure. Lower the caster by turning the exposed threaded stem (item **C**) on the caster clockwise. Make the adjustment a few turns at a time. **Repeat step 2.**
5. If the blades are not deflecting enough, raise the caster by turning the stem counter-clockwise to adjust the caster height to allow more down pressure on the squeegee. **Repeat step 2.**
6. Make sure there is even deflection on the entire length of the rear blade. Adjust the casters and retighten the wing jam nuts to lock the caster setting in place.
7. Pitch adjustment is necessary if the outer ends on the squeegee blade do not contact the floor and there is too much deflection in the middle area or if the outer ends are over deflected and there is no contact in the middle.
8. To adjust the pitch, Repeat step 2.
9. Loosen the two wing jam nuts (item **E**) that lock the pitch angle. Turning the knob (item **F**) clockwise or counter-clockwise controls the forward and backward pitch of the squeegee. Having the rear blades deflected uniformly along its entire length is the desired set-up.
10. Repeat step 2 until desired set-up is achieved.
11. In certain applications where a non-slotted front wiper blade (item **G**) is needed, detach the rear squeegee assembly by loosening the two wing bolts (item **H**). Unlock the toggle clamp (item **I**) on the front squeegee to release the front long strap (item **J**) and slide the front short strap (item **K**). Flip the blade over to the non-slotted side. Reattach the straps and lock the clamp back in place.
12. You can also easily replace the rear blade by unlatching the latch (item **N**) and removing the two rear straps (items **L & M**) by sliding them off the assembly. You can then flip the blade over in order to use a new edge for better wiping action.

THE SCV RIDER

This machine was designed with total operator comfort and ease of use in mind. All machine components have been designed as a total system to efficiently clean dirty floors. The SCV has four available scrub head types and sizes to fit specific applications. *Please contact your Minuteman representative for specific recommendations for the correct scrub head type, size, and brush type and chemical applications.*

Before using the machine, always perform the following steps to ensure proper machine operation.

- Check under the machine for leaks.
- Check the rear and side squeegees for wear and damage.
- Check the steering for proper operation.
- Check the solution and recovery tanks.

After using the machine, always perform the following steps:

- Check the battery charge level. Charge batteries if necessary. When charging batteries, extra precaution is required:
 - Battery acid can cause burns. When working on or around batteries, always wear protective clothing and safety glasses. Remove metal jewelry. Do not lay tools or metal objects on top of the batteries.
 - Charging batteries generate explosive gasses. **DO NOT CHARGE BATTERIES WHEN OPEN FLAMES OR SPARKS ARE PRESENT. DO NOT SMOKE.** Make sure the charger is turned off before disconnecting it from the batteries. Charge the batteries in a well-ventilated area. Fluid levels should be checked before and after charging and maintained at the proper levels. If low, add water until the metal plates are covered. If the machine is not used for an extended period of time, batteries should be kept fully charged with a boost charge once a week.
- Check for wire, string, or twine wrapped around the scrub brushes.
- Check the squeegees for wear and damage.
- Check the rear squeegee suction hose and off-aisle wand hose for obstructions.
- Empty and clean the debris box (cylindrical systems only).
- Drain and clean the recovery tank.
- Check under the machine for leaks.
- Check the service records to determine maintenance requirements.

WARNING!

- **Be sure you understand the machine controls and their functions.**
- **While on ramps or inclines, avoid sudden stops when tanks are filled.**
- **Avoid abrupt sharp turns. Slow down driving speed when going downhill.**
- **Always drive up when cleaning ramps.**

MACHINE OPERATION

Follow the instructions in preparing the machine for use as described in this manual.

1. While seated on the machine, adjust the steering wheel to desired position using the tilt lever.
2. Turn the **Key switch ON** (I). The Battery Gauge will light up and display the *Remaining Battery Life*.
3. Select one of the five available **Modes** on the **Control Console** for the required task. Refer to the *Operation Modes section* of this manual for a complete description of the functions.
4. Determine the direction you need to travel by selecting **forward** or **reverse** on the **Directional Switch**. Vary the pressure exerted on the accelerator pedal to propel the machine at the desired speed.
5. Stepping on the **Accelerator Pedal** turns on the *Transport, Brushes, Water Flow, Vacuum* and lowers the *Rear Squeegee* accordingly to the Mode selected. If the operator steps on the accelerator pedal before, or turns the key switch "ON" at the same time, the machine will not move as a safety precaution. Simply remove your foot off the pedal and step on the pedal again to drive the machine. Please refer to the *Main Operation Modes section* of this manual for a complete description of the functions.
6. When **Reverse** is selected on the Directional Switch, the Rear Squeegee is automatically raised when you step on the accelerator pedal. However, the scrub brushes will continue to rotate and solution will continue to flow.
7. Start scrubbing by driving the machine forward in a straight line at $\frac{3}{4}$ speed and overlap each pass by 2 to 3 inches. Adjust your speed, brush pressure, and solution flow according to the condition of the floor.

CAUTION!

To avoid any damage to the floor, keep the machine moving when the brushes are turned on.

8. When scrubbing, check behind the machine occasionally to see that all the dirty water is being picked up. If streaking occurs, your **Recovery Tank** may be *full*, the **Squeegee hose** may be *clogged*, or the **Rear Squeegee** may require some *adjustment*.
9. Make the necessary adjustments on the **Rear and Side Squeegees** if streaking occurs both in straight paths and in turns. Please refer to the *Rear Squeegee and Side Squeegee* section of this manual before making any adjustments.
10. In cases where the floors are extremely soiled and dirty, the **Double Scrub** mode may be needed. As described in the *Operation Modes section* of this manual, this mode allows the operator to be able to scrub an area without recovering the cleaning solution with the rear squeegee in the raised position (no vacuum) to allow the cleaning solution a longer time to loosen dirt. A final pass on the same area is made with the mode switched over to either **Full Function** or **Vacuum Only** mode to recover the dirty water.
11. The recovery tank has a safeguard for overflow protection to guard against water from entering the vacuum system when the recovery tank is full. The vacuum will stay ON for 15 seconds and then shut-off automatically. A ball float shut-off system has also been integrated into the Recovery Tank. When the dirty water reaches a certain level, the ball gets suctioned into the vacuum manifold and blocks the airflow thus, preventing the machine from picking up more liquid. When this happens, the operator is then required to stop scrubbing and empty the recovery tank.

12. To stop scrubbing, select the **Transport mode**. This will automatically stop the **Solution Flow**, raise the **Scrub deck**, and raise the **Rear squeegee** (there is a 15 second delay for the vacuum motor).
13. Drive the SCV to a designated dirty water disposal area and empty the Recovery tank. To empty, remove the **Drain hose** from its storage hanger. Unscrew the plug and hold the hose end above the water level in the tank to avoid sudden, uncontrolled flow of dirty water. With the plug completely off, carefully direct the water flow to the desired drain. Reinsert the plug and tighten and return to its storage hanger.
14. The recovery tank should be rinsed out to remove solids in the tank. Open the **Cleanout cap** to remove the **Stopper plug**. Tilt the recovery tank (similar to accessing the batteries) and clean the sludge that has settled in the sump area by either back flushing or by scraping it out. Be sure to tightly secure the **Stopper plug** and cleanout cap before continuing to operate the scrubber.
15. Refill the solution tank and continue scrubbing until the job is done or when the machine runs out of power.
16. The **battery gauge LEDs** will flash to signal the operator that the machine is almost out of power. Once this signal is displayed to the operator, *all functions will shut off* (brush will turn off and the scrub deck will raise up, water flow will cease, the rear squeegee will raise up and the vacuum motor will turn off) including the transport mode. The operator has to turn the **key switch OFF and then, ON to reset** the machine. The machine will then have only a few minutes left of reserve power to briefly use *Vacuum Only mode* to pick up any remaining solution on the floor and *Transport mode* to return to the charging station.

AFTER USE:

1. When finished scrubbing, select the **Transport mode**, *all functions will shut off* (brush will turn off and the scrub deck will raise up, water flow will cease, the rear squeegee will raise up and the vacuum motor will turn off). Drive the machine to a service area for daily maintenance and review items that may need service.
2. Empty the solution tank, by directly opening the **Garden hose valve** underneath the machine into a drain on the floor or use a garden hose and attach it to the fitting to remotely drain the solution tank. Rinse the tank with clean water to prevent any build-up of dried up chemicals that could cause clogging in the plumbing.
3. Empty the recovery tank as described on line **15** and **16**.
4. Remove the **brushes** or pad holders and rinse them in warm water and hang to dry.
5. Remove the **rear squeegee**, rinse with warm water and reinstall after cleaning.
6. Remove the **side squeegees**, rinse with warm water and remove the **debris box** (cylindrical system only) and clean thoroughly. The debris box can be removed from either side of the machine by tilting the box up and away from the housing and then pulling it out. Reinstall the debris box and side squeegees after cleaning.
7. Check the **maintenance schedule** on the next page and perform any required maintenance before storing the machine.
8. Store the machine indoors in a clean dry place. Keep from freezing. Leave solution and recovery tank lids open for ventilation to prevent odor build-up.
9. Turn **Key switch OFF (O)** and remove key.

MAINTENANCE SCHEDULE

Daily	Weekly	Monthly	Yearly
Charge Batteries	Check Each Battery Cell(s) Water Level	Lubrication – Grease Fittings, chains, etc.	Check Carbon Brushes
Check/Clean Tanks & Hoses	Inspect Scrub Housing Skirts		
Check/Clean/Rotate the Brushes/Pads	Inspect and Clean Solution Filter		
Check/Clean the Squeegee	Check Foot/Parking Brake for Wear & Adjustment		
Check/Clean Vacuum Shut-Off Float	Clean Spray jets on Cylindrical System		
Check/Clean the Vacuum Motor Foam Filter			
Clean Hopper on Cylindrical System			

- Have Minuteman check the vacuum motor carbon motor brushes once a year or after 300 operating hours. The brush motor carbon brushes should be checked every 500 hours or once a year.

NOTE: Refer to the Service Manual for more detail on maintenance and service repairs.

LUBRICATING THE MACHINE

Regularly scheduled lubrication of certain machine parts should be performed to insure trouble-free operation of the machine. *Apply a generous amount of grease into the fittings on the machine until grease seeps out around the bearings.*

The grease points are listed below:

- *Rear squeegee caster wheel axle (2)*
- *Rear squeegee caster wheel stem (2)*
- *Side squeegee caster wheel axle (2)*
- *Side squeegee caster wheel stem (2)*
- *Steering wheel chain sprockets and idlers*

Apply lubricant or light machine oil to lubricate the:

- *Rear squeegee general pivot points*
- *Side squeegee general pivot points*
- *Scrub deck linkages*
- *Drive wheel assembly seals.*

GENERAL MACHINE TROUBLESHOOTING

Problem	Possible Cause	Remedy
Poor water pick-up	Worn or torn squeegee blades	Rotate or replace blades
	Squeegee out of adjustment	Adjust so blades touch floor evenly across entire width
	Recovery tank full	Empty recovery tank
	Recovery tank drain hose leak	Secure drain hose cap or replace
	Recovery tank lid gasket leak	Replace gasket lid cover properly
	Debris caught in squeegee	Clean squeegee
	Vacuum hose clogged	Remove debris and flush hose
	Using too much solution	Adjust solution control valves
	Vacuum hose to squeegee or recovery tank disconnected to squeegee or damaged	Reconnect or replace squeegee hose
Poor scrubbing performance	Worn brushes	Rotate or replace brushes
	Wrong brush or cleaning chemical	Consult Minuteman
	Debris caught on scrub brushes	Remove debris
	Moving machine too fast	Slow down
	Low battery charge	Recharge batteries
Inadequate solution flow or no solution to the floor	Solution tank empty	Fill solution tank
	Recovery tank full	Empty recovery tank
	Solution lines, valves, filter or spray jets clogged	Flush lines, and clean solution filter and spray jets.
	Solution solenoid valve	Clean or replace valve
Machine does not run	Emergency stop switch tripped	Activate switch by turning as indicated by arrows.
	Operator seat safety switch	Operator has to be seated. Check for open circuit and replace
	Main system controller	Check error fault codes (See page 15)
	Tripped 100 amp circuit breaker	Check for electrical short circuit Reset machine: Rest breaker and turn key switch off and restart.

No FWD/REV drive	Drive system speed controller.	Check error fault codes (See page 15) Reset machine: Turn key switch off and restart.
	Emergency stop switch tripped	Activate switch by turning as indicated by arrows.
Vacuum motor does not turn on	Recovery tank full	Empty recovery tank
	Excessive foaming in recovery tank.	Empty recovery tank. Use less or change chemical. Use defoaming agent.
	Five LEDs flashing on Battery Gauge	Check for motor overload. Reset machine: Turn key switch off and restart.
Poor sweeping performance (Cylindrical System)	Debris box full	Empty and clean debris box
	Brushes worn	Replace brushes
	Bristles have taken a set	Rotate brushes
Solution tank empty indicator light on	Solution tank empty	Refill solution tank
	Faulty float switch	Replace float switch

EXPLODED VIEWS MAIN ASSEMBLY I

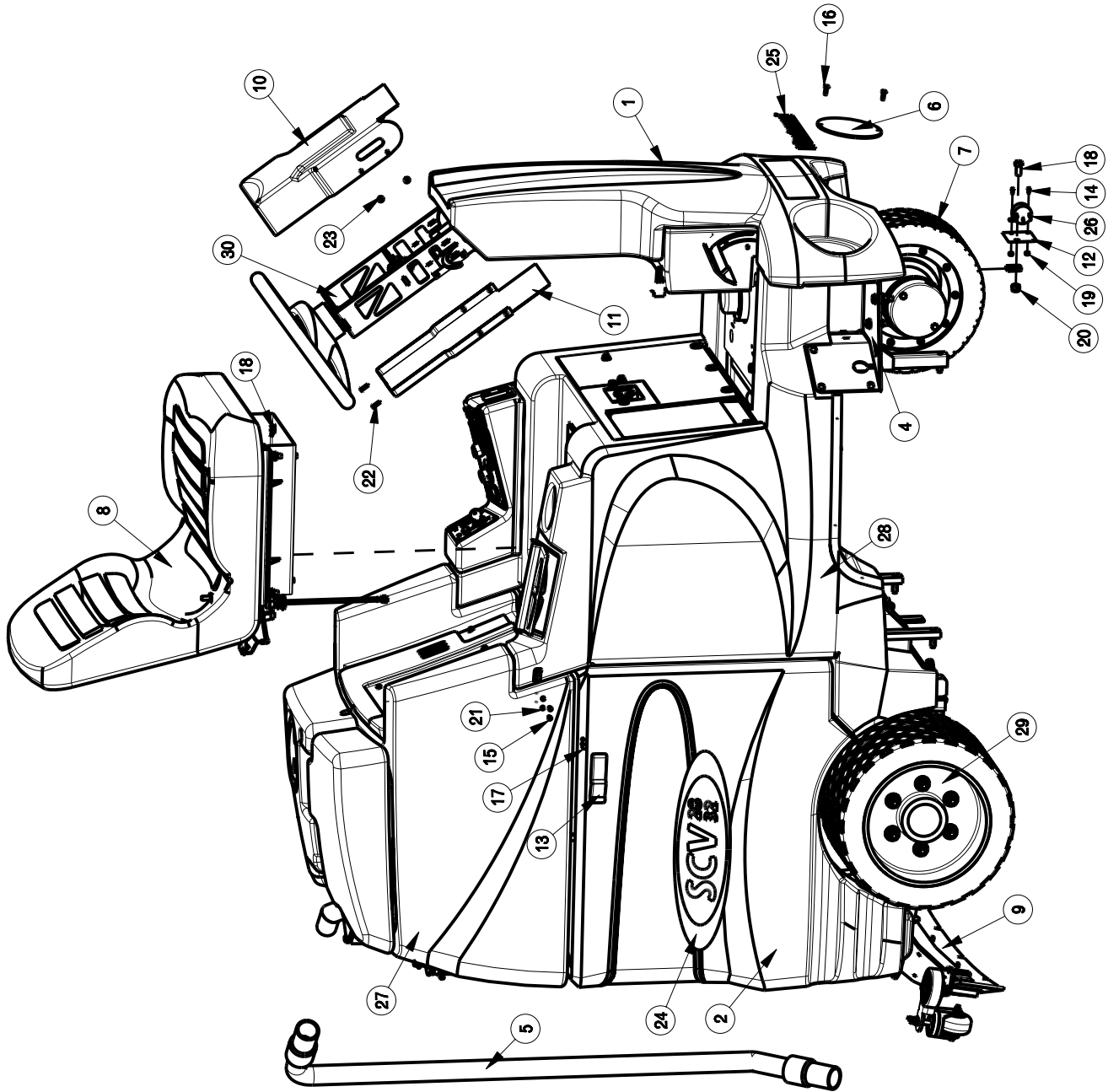

MAIN ASSEMBLY I BOM

BILL OF MATERIAL			
ITEM	PART NO.	REQ'D	DESCRIPTION
1	281001	1	BUMPER FRONT
2	281014	1	BATTERY TRAY ASSY
3	281066	1	ANTISKID STEP, LH
4	281067	1	ANTISKID STEP, RH
5	281078	1	HOSE ASSY - SQUEEGEE, SCV 28/32
6	281139	2	COVER, HEADLIGHT BLANK 5", SCV2832
7	281251	1	FRONT DRIVE ASSY
8	281365	1	SEAT SUB-ASS'Y
9	281579-SBG	1	SCV SQUEEGEE BLADE ASSY 32" SBG
10	281991	1	STEERING COVER, TOP
11	281992	1	STEERING COVER, BOTTOM
12	281996	1	BKT, FOR HORN, SCV2832
13	450207	2	LATCH, SOFT #C7-10
14	710203	2	SCR-MC 6-32 X .37 ST PL PAN HD
15	710328	4	SCR-MC 8-32 X .37 ST PL - ROUND HEAD
16	711160	4	#10 X 5/8 HI-LO
17	711161	4	SCR-HI/LO 10 X 3/4 STL BLK ZINC
18	711241	5	SCR-HEX 3/8 -16X .75" ZP
19	711371	2	NUT-NYLOC 6-32 STL ZINC
20	711380	5	NUT-NYLOC 3/8-16 NUT
21	711542	4	WSR-HELICAL #8
22	712812	2	SCR-MC 10-24 X .62 PPH ST PL
23	712816	4	SCR-MC 10-24 X .37 STPL
24	715298	2	DECAL, SCV 28/32
25	715385	1	MINUTEMAN LOGO 1.4 X 9.6
26	748200	1	HORN / BACK UP ALARM, SCV 24/26
27	281010E	1	RECOVERY TANK / LID SUB-ASSEMBLY
28	281012E	1	SOLUTION TANK ASS'Y - SCV 28/32
29	281201E-SBG	1	REAR AXLE ASSY - SHAIBA
30	282301E	1	STEERING ASSEMBLY, SCV2832

MAIN ASSEMBLY II

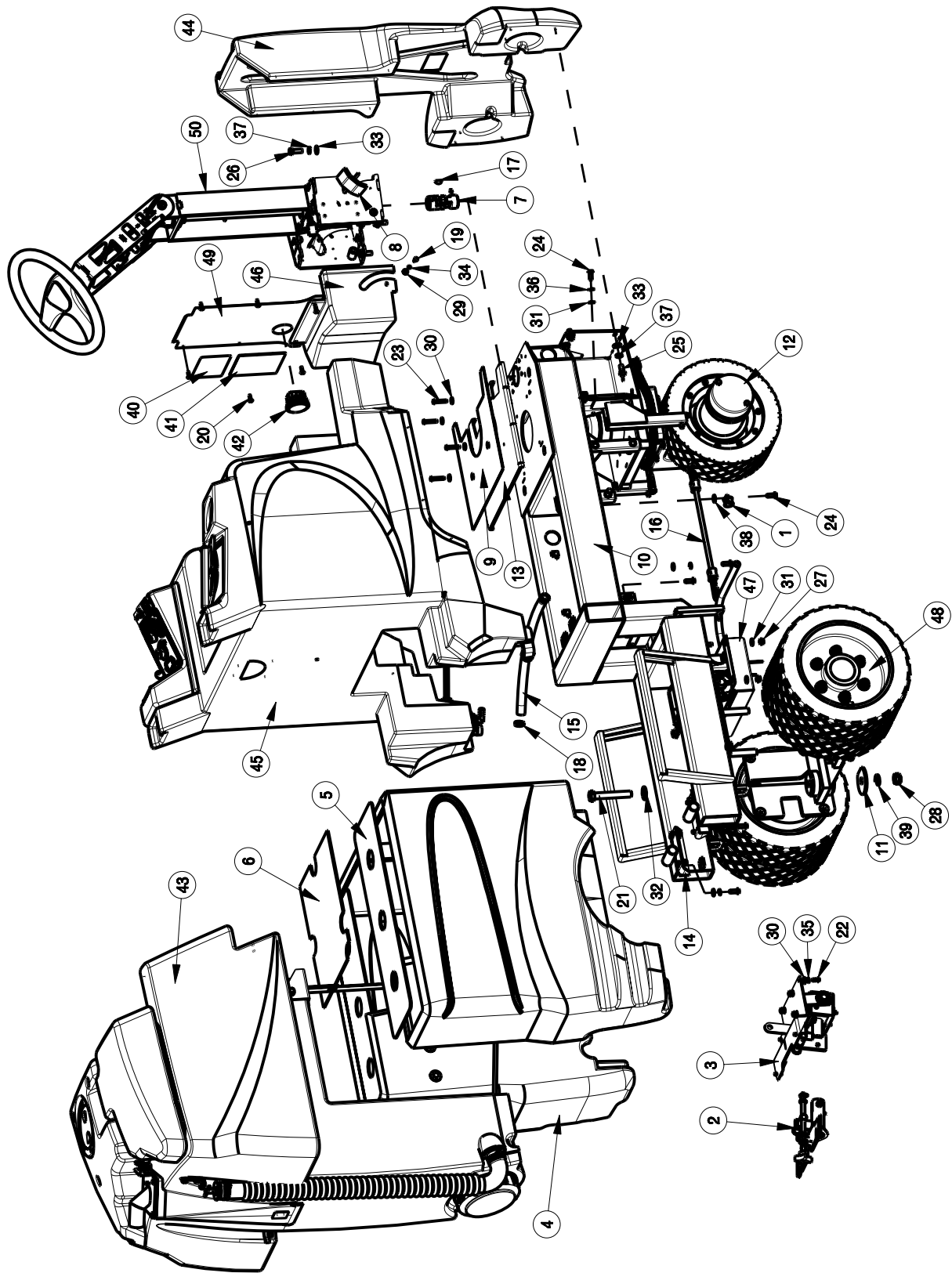

MAIN ASSEMBLY II BOM

BILL OF MATERIAL			
ITEM	PART NO.	REQ'D	DESCRIPTION
1	82-54-A	1	CLAMP, MS21333-114
2	241730-1	1	REAR SQUEEGEE ASSY TOP, SCV 24/26
3	241735	1	REAR SQUEEGEE MECH ASSY
4	281014	1	BATTERY TRAY ASSY
5	281026	2	2800 BATTERY COVER SIDE
6	281027	1	2800 BATTERY COVER CENTER
7	281051	1	SPIDER COUPLING, 3/4"
8	281065	1	ANTISKID PEDAL
9	281068	1	ANTISKID FLOOR
10	281101	1	MAINFRAME WMT, 28" SCRUBBER
11	281211	4	SNUBBING WSR
12	281251	1	FRONT DRIVE ASSY
13	281351	1	FLOOR PANEL WELDMENT
14	281360	2	FIXED SLIDER WELDT
15	281428	1	SOLUTION BALANCE HOSE
16	281445	1	BUNGEE CORD - 16"
17	383277	2	KEY WOODRUFF 3/16 X 3/4
18	383347	2	CRIMP CLAMP 1/2 HOSE SS 185R
19	710356	1	SCR-MC 10-32X.62 STPL
20	711160	6	#10 X 5/8 HI-LO
21	711173	4	BLT-HH 5/8-11 X 4 (GR 5)
22	711202	4	BLT-HH 1/4-20 X 0.50 STPL
23	711210	4	BLT-HH 1/4-20 X 1.25 STPL
24	711228	17	BLT-HH 5/16-18 X .75 ST PL
25	711241	6	SCR-HEX 3/8 -16X .75" ZP
26	711242	6	BLT-HEX 3/8 -16X1.00 ZP
27	711374	4	NUT-NYLOC 5/16-18
28	711445	4	NUT HEX 5/8 X 11 PLATED
29	711503	1	WSR, FLAT#10
30	711505	8	WSR-FLAT 1/4
31	711506	20	WSR-FLT .344 X .690 X .062 STL ZINC
32	711511	4	WSR-FLAT .62 X 1.31 X .09
33	711515	12	WSR-FLAT .406 X .812 X .0625
34	711534	1	WSR-EXTERNAL LOCK #10
35	711544	4	WSR-HELICAL 1/4
36	711545	16	WSR-HELICAL 5/16
37	711546	12	WSR-HELICAL 3/8
38	711575	1	WSR-FLT .31x.75x.06ST
39	712315	4	WSR-HELI .64 X 1.26 X .06 PL
40	715901	1	WARNING DECAL, TANK LATCH
41	715908	1	DECAL, DIAGNOSTIC CODES SCVS
42	740539	1	HOUR METER 10 - 80 VDC
43	281010E	1	RECOVERY TANK / LID SUB-ASSEMBLY
44	281011E	1	FRONT BUMPER ASM
45	281012E	1	SOLUTION TANK ASS'Y - SCV 28/32
46	281024E	1	STEERING COLUMN COVER - BOTTOM
47	281098E	1	PUMP SUB-ASSEMBLY
48	281201E-SBG	1	REAR AXLE ASSY - SHAIBA
49	281429E	1	STEERING COLUMN REAR COVER - TOP
50	282301E	1	STEERING ASSEMBLY, SCV2832

MAINFRAME ASSEMBLY I - SBG

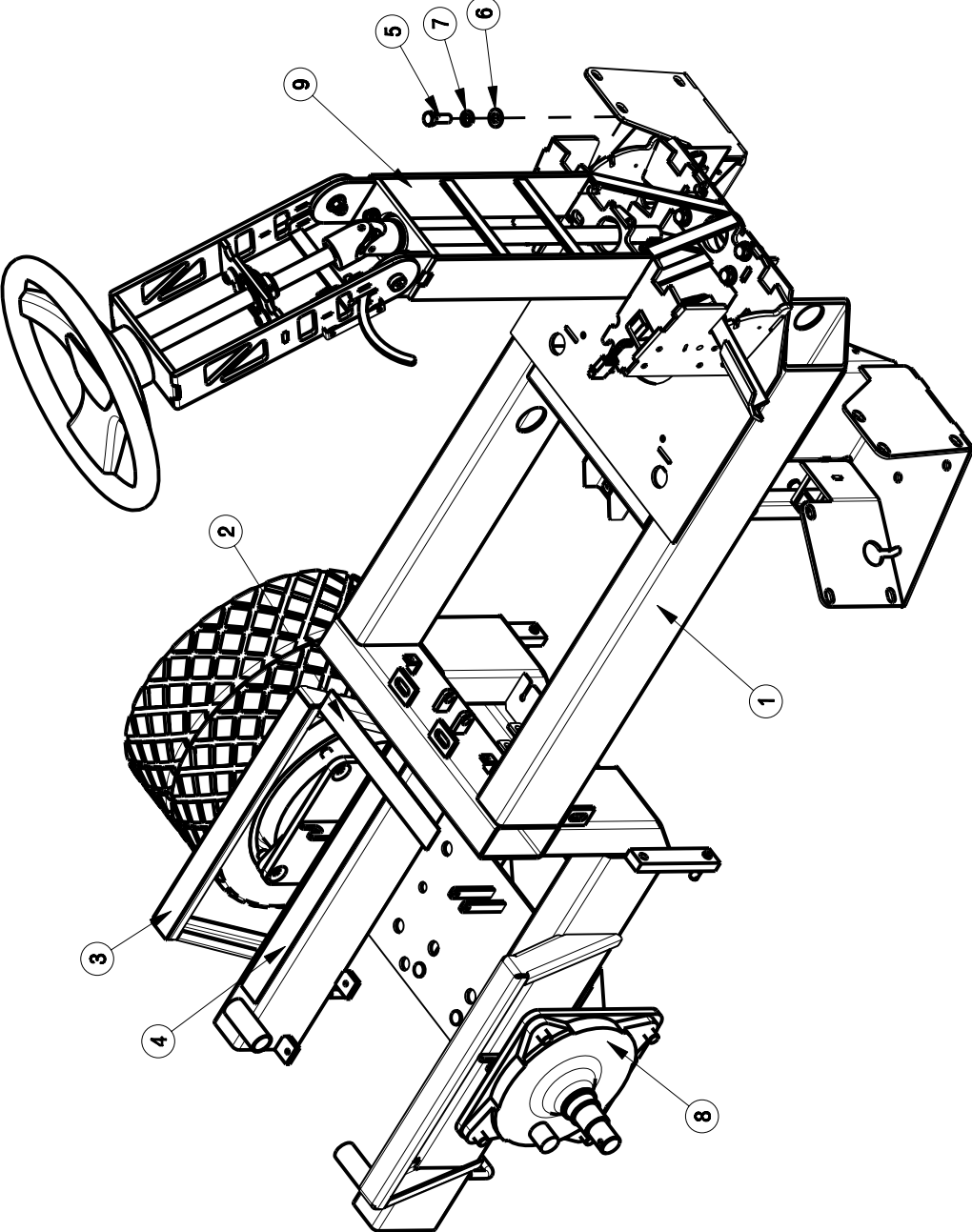

MAINFRAME ASSEMBLY II

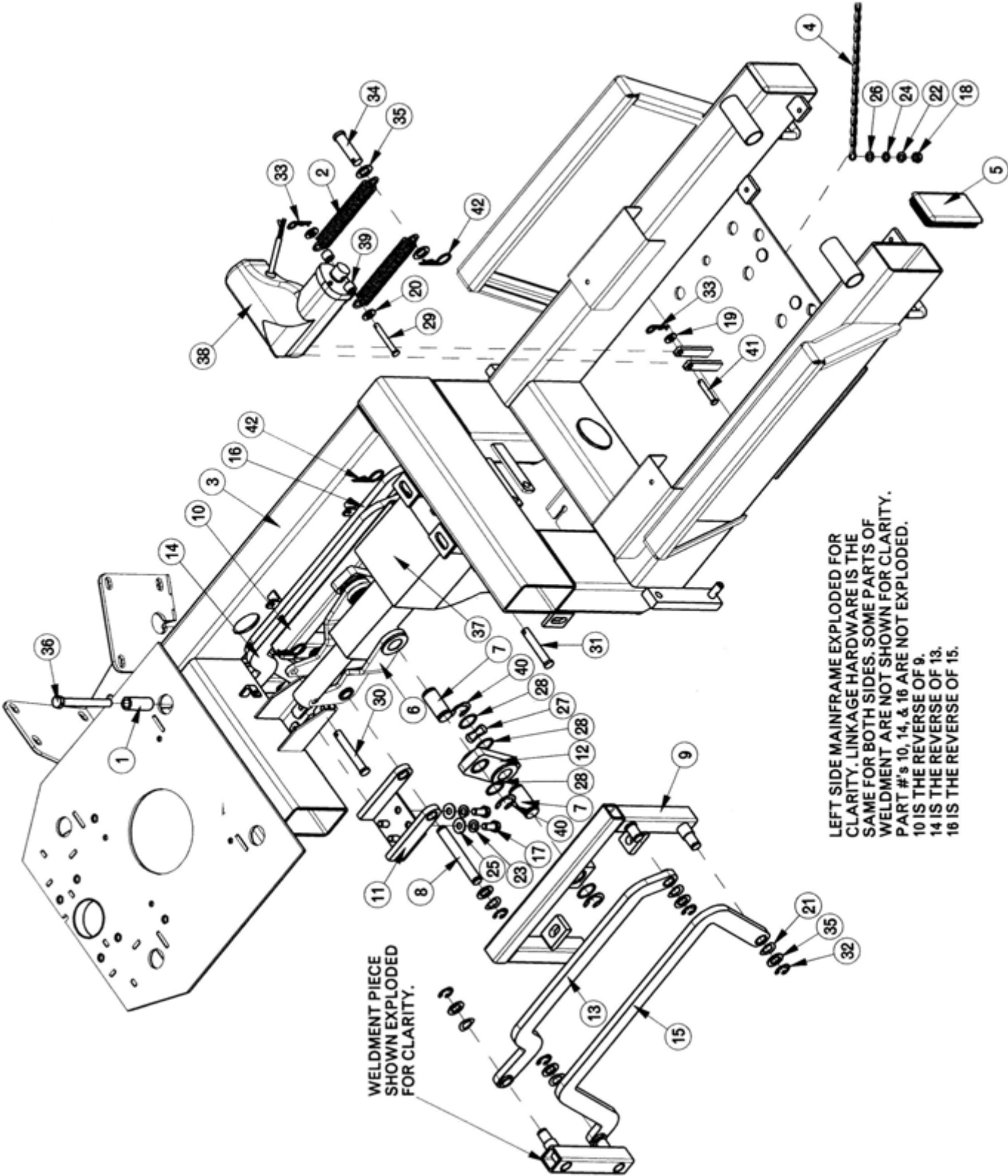

MAINFRAME ASSEMBLY II BOM

BILL OF MATERIAL			
ITEM	PART NO.	REQ'D	DESCRIPTION
1	260125	1	BUSHING YOKE, .407 X 1.687 STL
2	281046	2	SPRING, EXTENSION - 4.50"
3	281101	1	MAINFRAME WMT, 28" SCRUBBER
4	281200	1	DRAG CHAIN ASSY, FRAME
5	281446	2	ENDCAP, TUBING 2" X 4"
6	281451	1	CRANK WMT W/ BUSHING ASS'Y
7	281458	4	LINK ATTACHMENT SHAFT
8	281459	1	CRANK PIVOT SHAFT
9	281461	1	LIFT WMT LH W/ BUSHING ASS'Y
10	281463	1	LIFT WMT RH W/ BUSHING ASS'Y
11	281471	1	ACTUATOR ATM'T WMT W/ BUSHING ASS'Y
12	281475	2	LIFT LINK ASS'Y
13	281477	1	UPPER LINK ASS'Y, LEFT
14	281478	1	UPPER LINK ASS'Y, RIGHT
15	281479	1	LOWER LINK ASS'Y, LEFT
16	281480	1	LOWER LINK ASS'Y, RIGHT
17	711228	4	BLT-HH 5/16-18 X .75 ST PL
18	711316	2	NUT-HEX 1/4-20 ST PL
19	711505	1	WSR-FLAT 1/4
20	711506	2	WSR-FLT .344 X .690 X .062 STL ZINC
21	711524	10	WSR-WAVE .52 X .87 X .01
22	711544	2	WSR-HELICAL 1/4
23	711545	4	WSR-HELICAL 5/16
24	711564	1	WSR-EXTERNAL LOCK 1/4
25	711575	4	WSR-FLT .31x.75x.06ST
26	711577	2	WSR-FLAT 260 X .50 X .020THK
27	711583	4	WSR-WAVE .78 X 1.00 X .02
28	711588	12	WSR-FLAT .75X1.00X.025
29	711675	1	CLEVIS PIN 1/4 X 1-7/8
30	711677	1	CLEVIS PIN 3/8 X 2-5/8
31	711678	1	CLEVIS PIN 3/8 X 2-1/4
32	711713	10	RETAINING RING - "E" TYPE EXT .500
33	711808	2	COTTER PIN-HAIR #13
34	712109	1	CLEVIS PIN, 1/2 x 1-3/4
35	712310	12	WSR- FLAT .52 X .87 X .06 PL
36	713051	1	BLT-HH 3/8-16 X 3.75 #5
37	742712-2	1	ACTUATOR BRUSH, W/WEATHER PACK
38	748009-1	1	ACTUATOR, W/WEATHER PACK SCV SQUEEGEE
39	762371	2	BUSHING .260X.50X.37
40	809148	8	RETAINING RING - "E" TYPE EXT .75
41	832974	1	CLEVIS PIN, 1/4 x 1-3/8
42	833374	3	HAIRPIN COTTER 3/8

FRONT DRIVE ASSEMBLY

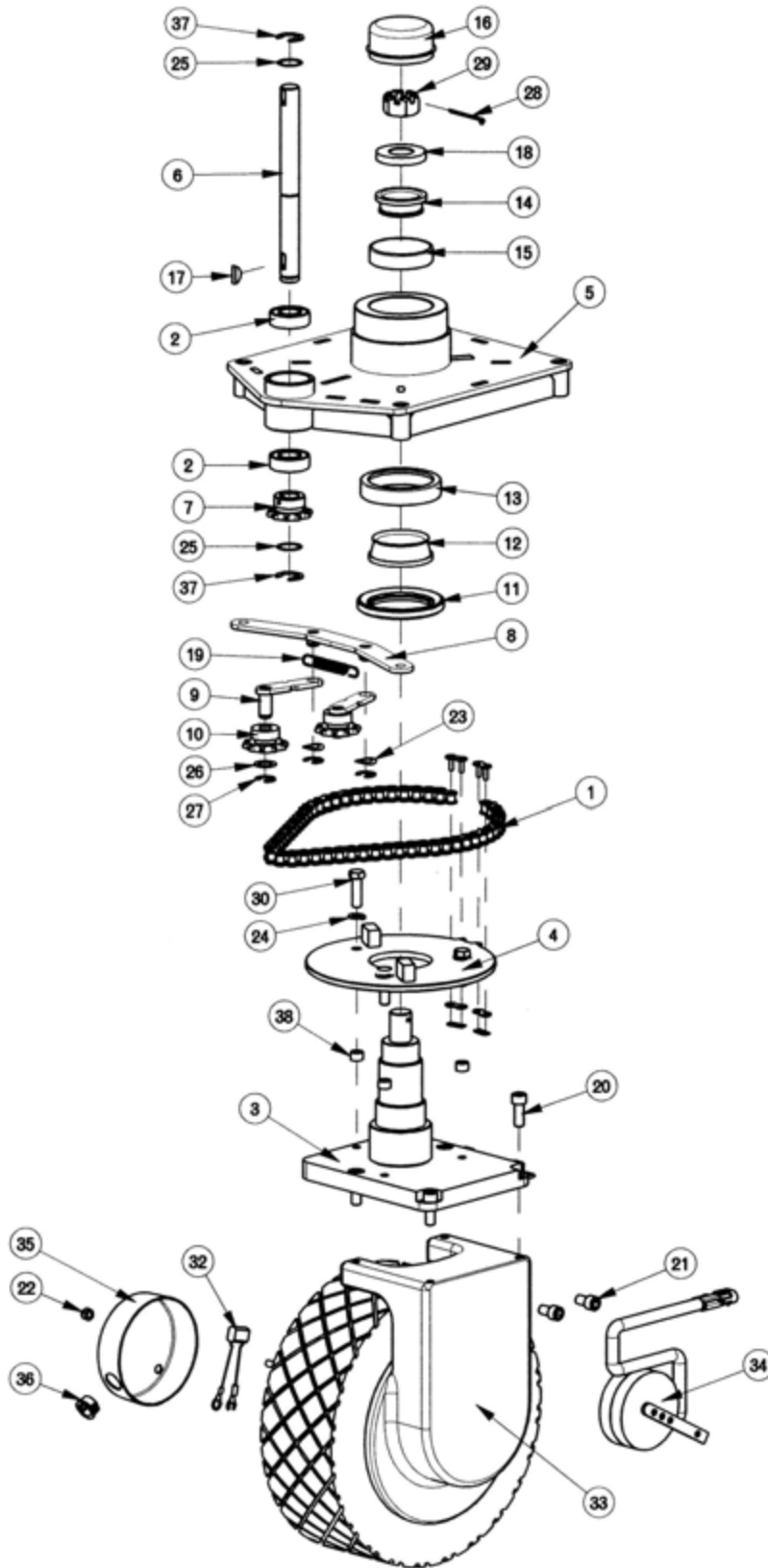

FRONT DRIVE ASSEMBLY BOM

BILL OF MATERIAL 281251			
ITEM	PART NO.	REQ'D	DESCRIPTION
1	281054	1	CHAIN, STEERING No. 40, 27.5"
2	281057	2	BEARING 3/4" RADIAL
3	281252	1	SPINDLE WMT
4	281254	1	STEERING DISC WMT
5	281260	1	MOUNT WMT, FRONT DRIVE
6	281267	1	STEERING SPROCKET SHAFT
7	281268	1	SPROCKET-RC #40, 10 TEETH, 3/4" BORE
8	281276	1	IDLER BASE WMT, FRONT DRIVE
9	281279	2	IDLER ARM WMT, FRONT DRIVE
10	281282	2	IDLER SPROCKET-RC #40, 10 TEETH
11	383074	1	SPINDLE SEAL
12	383075	1	BEARING CONE (LM104949)
13	383076	1	BEARING CUP (LM104911)
14	383077	1	BEARING CONE (LM104949)
15	383078	1	BEARING CUP (LM104911)
16	383250	1	GREASE CAP
17	383277	1	KEY WOODRUFF 3/16 X 3/4
18	383364	1	THRUST WASHER
19	430051	1	RETURN SPRING-3.00"
20	710858	4	SCR-SC 3/8-16 X 1.00
21	710991	2	SCR-SC 3/8-24 X 5/8 ST PL
22	711352	2	NUT-ACORN 1/4-20 ST N1
23	711524	2	WSR-WAVE .52 X .87 X .01
24	711546	3	WSR-HELICAL 3/8
25	711588	2	WSR-FLAT .75X1.00X.025
26	711594	2	WSR-FLAT .56 X .88 X .03
27	711713	4	RETAINING RING - "E" TYPE EXT .500
28	711807	1	COTTER PIN .12 X 1.75
29	712113	1	CASTLE NUT
30	713043	3	BLT-HH 3/8-16 X 1 1/4 #5
31	740099	5	CABLE TIE - SMALL
32	744016-1	2	CAP .15 MICROFARAD 5/16R-1/4FORK
33	748010	1	IMPERIAL ELEC CHASSISDRIVE 12"
34	748010-3	1	E MAG BRAKE ASSY
35	748049	1	VAC FRMED DRIVE MOTOR COVER
36	748122	1	BUSHING, HEYCO 2103 I.D .625.
37	809148	2	RETAINING RING - "E" TYPE EXT .75
38	809247	3	STEERING PLATE SPACER

STEERING ASSEMBLY

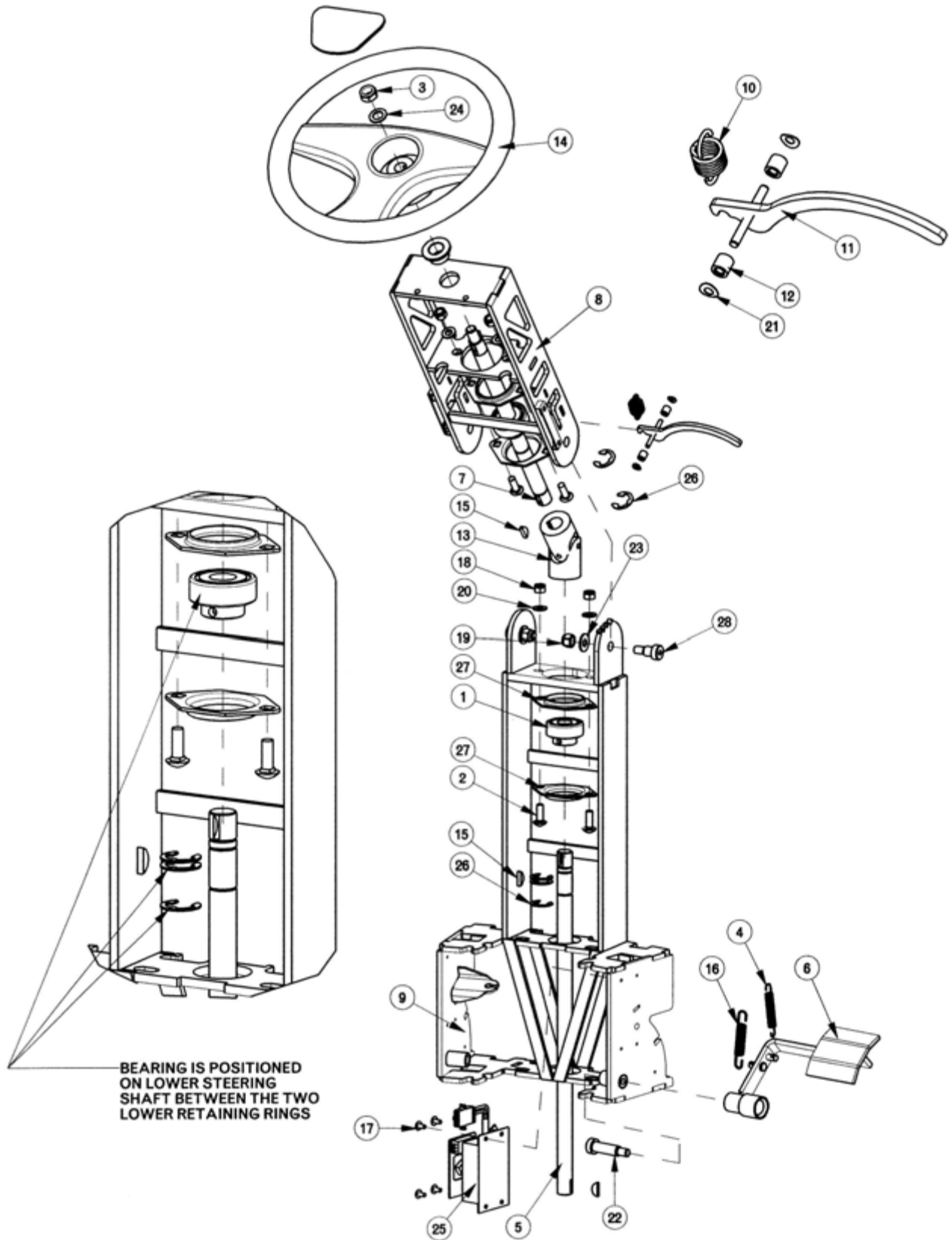

STEERING ASSEMBLY BOM

BILL OF MATERIAL - 282301E			
ITEM	PART NO.	REQ'D	DESCRIPTION
1	66-138-A	2	BEARING, 3/4"
2	70-516-16	4	BLT-CAR 5/16-18 X 1.00
3	363-816	1	NUT NYLOC 1/2-20
4	281047	1	SPRING, EXTENSION - 2.75"
5	281328	1	SHAFT,LOWER STEERING
6	281331	1	ACCEL PEDAL WMT
7	281484	1	SHAFT,UPPER STEERING
8	281989	1	STEERING ASSY, TOP, SCV2832
9	282302	1	STEERING WELDMENT, LOWER
10	282303	1	SPRING - EXTENSION 1.375" F.L.
11	282309	1	ADJUSTMENT LEVER AND PIVOT PIN ASSY
12	282310	2	BUSHING - ADJ. LEVER AND PIVOT PIN ASSY
13	383098	1	UNIVERSAL JOINT
14	383152	1	STEERING WHEEL
15	383277	4	KEY WOODRUFF 3/16 X 3/4
16	430051	1	RETURN SPRING-3.00"
17	710153	4	SCR-MC 10-32X.63 TH ZINC
18	711374	4	NUT-NYLOC 5/16-18
19	711380	2	NUT-NYLOC 3/8-16 NUT
20	711506	4	WSR-FLT .344 X .690 X .062 STL ZINC
21	711521	2	WSR-WAVE .21 X .44 X .02
22	712102	1	BLT- SHLDR 1/2 X 1-1/2
23	712301	2	WSR-FLAT .87 X .38 X .06
24	712310	1	WSR- FLAT .52 X .87 X .06 PL
25	748013-1	1	POTENTIOMETER BOX ASSEMBLY
26	809148	5	RETAINING RING - "E" TYPE EXT .75
27	340742MCH	4	BEARING FLANGE, SHEARED
28	712099PLT	2	BLT- SHLDR 1/2 X 5/8

SOLUTION TANK ASSEMBLY / SEAT ASSEMBLY

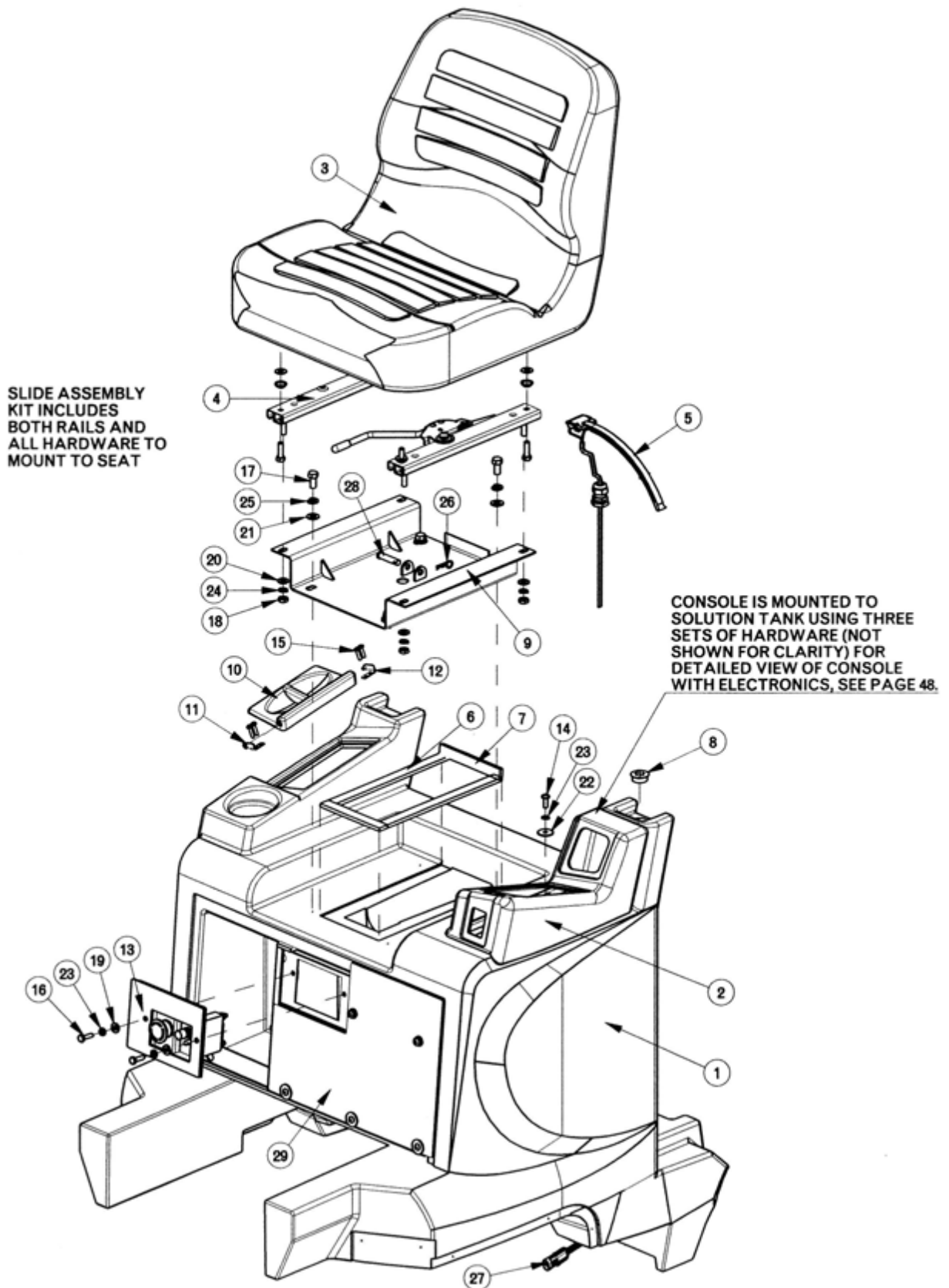

SOLUTION TANK ASSEMBLY / SEAT ASSEMBLY BOM's

BILL OF MATERIAL - 281012E, 281365			
ITEM	PART NO.	REQ'D	DESCRIPTION
1	281002	1	SOLUTION TANK - 2800
2	281005	1	SCV 28/32 CONSOLE
3	281085	1	ASS'Y SEAT, SUPER SUBURBAN
4	281086	1	SLIDE ASS'Y KIT
5	281087-1	1	SWITCH, SEAT
6	281363	2	SEAT GASKET - LONG
7	281364	2	SEAT GASKET - SHORT
8	281371	1	VENT PLUG
9	281376	1	28 SEAT BRACKET WMT
10	281380	1	SOLUTION TANK PLASTIC COVER
11	281381	1	SOLN TANK HINGE SUB-ASSY - RIGHT
12	281382	1	SOLN TANK HINGE SUB-ASSY -LEFT
13	281401	1	E-STOP ASS'Y
14	710380	13	SCR-MC 1/4-20 X .75 ST PL
15	711161	4	SCR-HI/LO 10 X 3/4 STL BLK ZINC
16	711206	2	BLT-HH 1/4-20 X .87 ST PL
17	711241	4	SCR-HEX 3/8 -16X .75" ZP
18	711319	4	5/16-18 HEX NUT
19	711505	12	WSR-FLAT 1/4
20	711506	4	WSR-FLT .344 X .690 X .062 STL ZINC
21	711515	4	WSR-FLAT .406 X .812 X .0625
22	711519	3	WSR- FLAT .25 X 1.01 X .06
23	711544	15	WSR-HELICAL 1/4
24	711545	4	WSR-HELICAL 5/16
25	711546	4	WSR-HELICAL 3/8
26	711808	1	COTTER PIN-HAIR #13
27	742708-4	1	FLOAT SWITCH W/WEATHER PACK
28	831965	1	3/8 x 1.63" CLEVIS PIN
29	281407E	1	ELECTRICAL PANEL ASS'Y SCV 28/32

ELECTRICAL PANEL

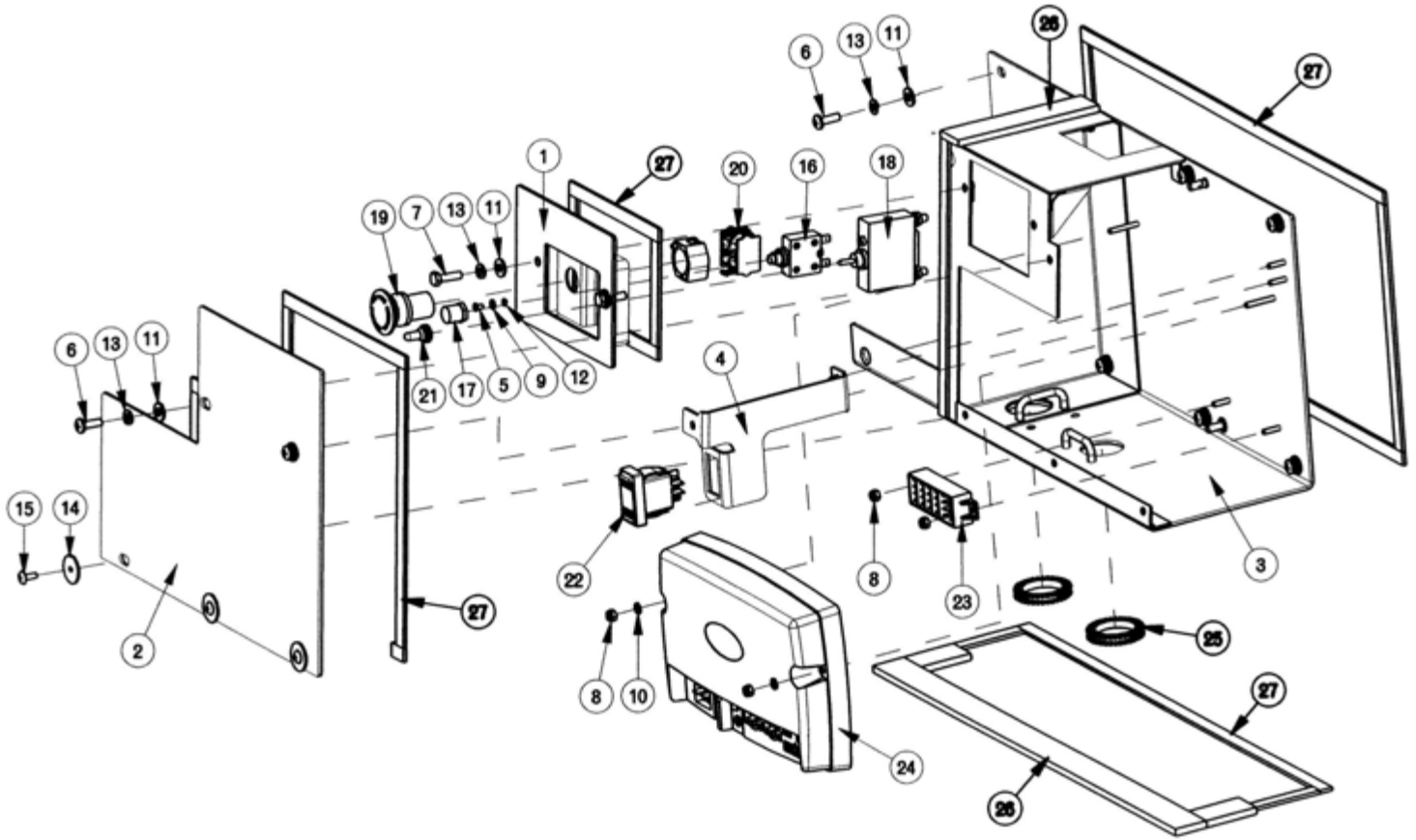

BILL OF MATERIAL			
ITEM	PART NO.	REQ'D	DESCRIPTION
1	281402	1	E-STOP WELDMENT
2	281412	1	ELECTRICAL COVER PANEL
3	281910	1	ELECTRICAL PANEL WMT, 2800
4	281982	1	ELECTRICAL CVR PNL SUPPORT BRKT
5	710202	1	SCR-MC 6-32 X .25 ST PL PAN HD
6	710380	10	SCR-MC 1/4-20 X .75 ST PL
7	711206	2	BLT-HH 1/4-20 X .87 ST PL
8	711372	6	NUT-NYLOC 8-32 STL ZINC
9	711501	1	WSR-FLAT # 6
10	711502	4	WSR-FLT .170 x.38 x.032 STL ZINC
11	711505	12	WSR-FLAT 1/4
12	711541	1	WSR-HELICAL #6 ST PL
13	711544	12	WSR-HELICAL 1/4
14	711599	3	WSR-FLT .187 X 1.00 X .06
15	712822	3	SCR-MC TR HD 10-24 X .50 SS
16	742350	1	CIRCUIT BREAKER 6 AMP
17	742748	1	CIRCUIT BREAKER BOOT
18	748012	1	CIRCUIT BREAKER 100A
19	748014	1	EMBERGENCY PUSHBUTTON ACTUATOR, 2800
20	748015	1	CONTACT BLOCK, 2800
21	748032	1	CIRCUIT BREAKER, BOOT FOR 748012
22	748152	1	SWITCH, ON-OFF-ON, SCV2832
23	748153	1	TERMINAL BLOCK EAGLE 3
24	748174	1	CONTROLLER,TRIO PLUS SCV2832E
25	281449	2	SERRATED GROMMET STRIP - .187IN
26	806006	3'	GASKET
27	830557	11.25'	DORTITE 1/2 INCH RM 1 F

CONSOLE

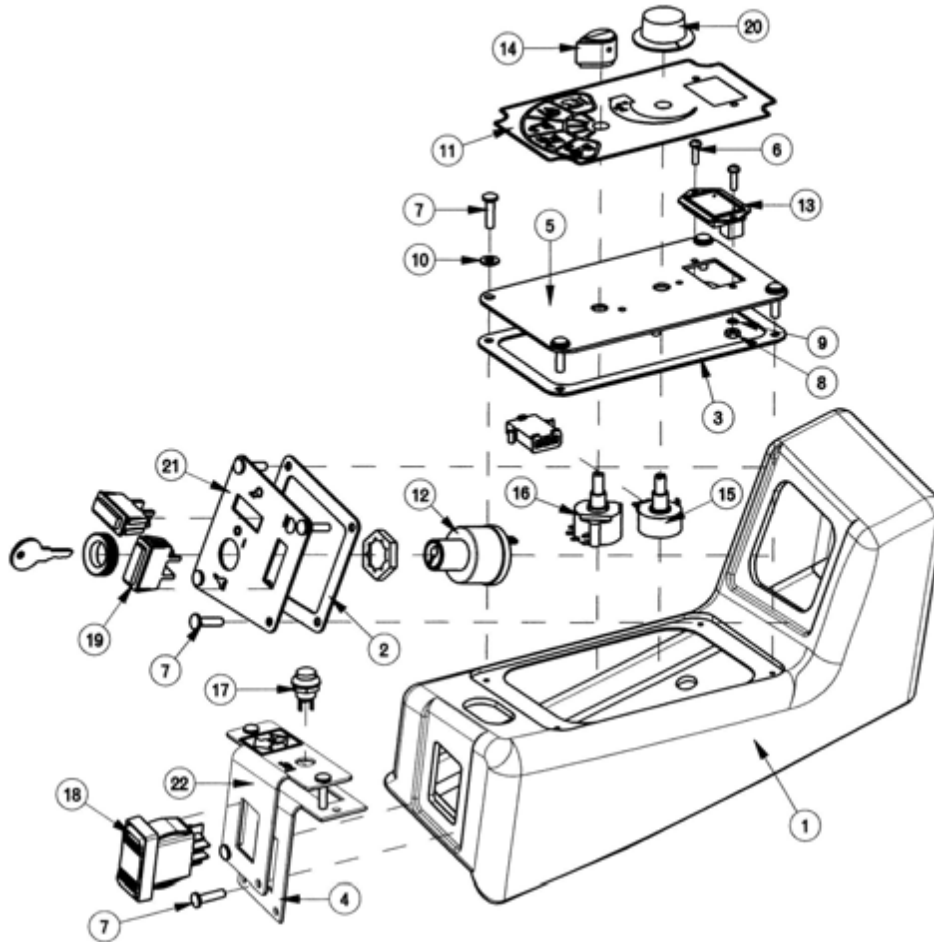

BILL OF MATERIAL			
ITEM	PART NO.	REQ'D	DESCRIPTION
1	281005	1	SCV 28/32 CONSOLE
2	281372	1	GASKET - IGNITION SWITCH PANEL
3	281373	1	GASKET - MEMBRANE SWITCH
4	281375	1	GASKET - DIRECTION SWITCH
5	281499	1	BKT, CONTROLS, SCV2832
6	710204	2	SCR-MC 6-32 X .50 ST PL PAN HD
7	711161	12	SCR-HI/LO 10 X 3/4 STL BLK ZINC
8	711301	2	NUT-HEX 6-32 ST PL
9	711541	2	WSR-HELICAL #6 ST PL
10	712320	4	WSR-NYLON .22 X .45 X .04
11	715455	1	DECAL, SCV CONTROLS, 28/32
12	742927	1	SWITCH, KEY 2 POLE
13	747011-1	1	BATT GAUGE ASSY TRUE CHARGE 36V
14	747020	1	KNOB-MODE SELECTOR
15	747025	1	POTENTIOMETER ASSY WATER FLOW
16	747027	1	SWITCH ASSY, MODE SELECTOR
17	748047	1	HORN SWITCH, SCV 36V
18	748151	1	SWITCH, ON-ON, DPDT
19	748154	2	SWITCH, BLANK, 742716
20	809874	1	KNOB, SPEED CONTROL
21	281378SP	1	IGNITION SWITCH PANEL
22	281497SP	1	DIRECTION CONTROL PANEL

RECOVERY TANK I

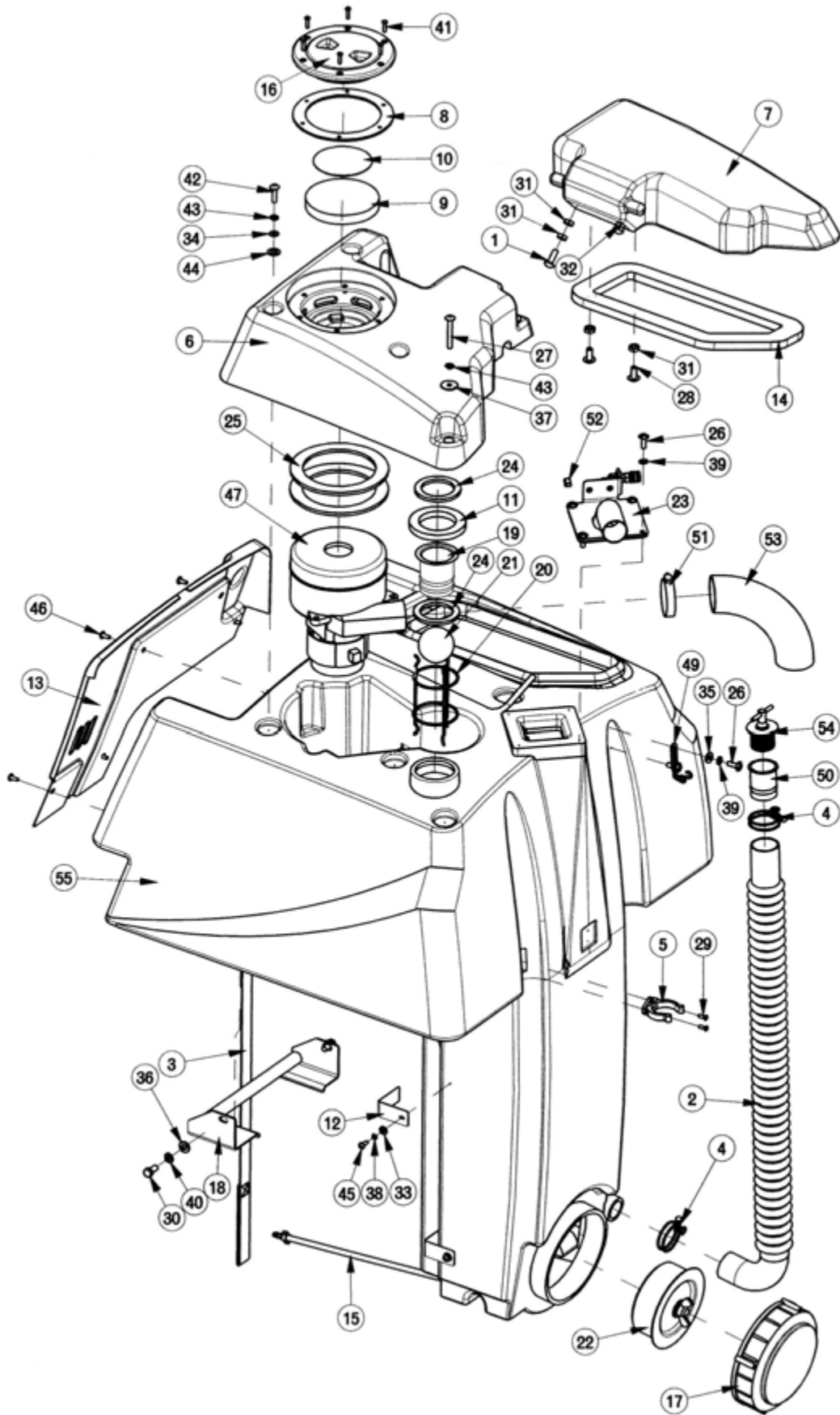

RECOVERY TANK I BOM

BILL OF MATERIAL - 281010E			
ITEM	PART NO.	REQ'D	DESCRIPTION
1	70-516-16	2	BLT-CAR 5/16-18 X 1.00
2	200198	1	DUMP HOSE
3	241433	1	RECOVERY TANK SAFETY STRAP, SCV 24/26
4	260203	2	WIRE GRIP HOSE CLAMP
5	260579	1	TOOL CLIP, 1.5" HOSE
6	281006	1	LID - FIXED 2800 RECOVERY TANK
7	281007	1	LID-MOVABLE 2800 RECOVERY TANK
8	281018	1	GASKET, NEO 6.00 X 4.50 X .125
9	281055	1	VAC MOTOR FILTER
10	281056	1	VAC MOTOR INLET SCREEN
11	281073	1	INLET GASKET
12	281076	3	2800 REC TANK BRACKET
13	281099	1	WIRE COVER
14	281358	1	GASKET, MOVABLE LID - SCV
15	281391	1	SOL. FEED HOSE,OFF AISLE SUB-ASY
16	281423	1	FILL CAP W/CHAIN ASSY 4.00
17	281432	1	CAP 6", CLEAN OUT SCV
18	281437	1	STRAP HOLDER WMT
19	281439	1	SHUTOFF FLANGE TUBE
20	281440	1	FLOAT CAGE, SCV
21	281442	1	FLOAT BALL, SCV
22	281444-1	1	STOPPER PLUG ASSY
23	281496	1	VAC INLET ASSY, SCV2832
24	281950	2	FLOAT CAGE GASKET
25	380035	2	MOTOR GASKET
26	710180	6	SCR-MC TR HD 1/4-20x.75 STL ZINC
27	710190	2	SCR-MC 1/4-20 X 2.00 TRUSS PL SS
28	710197	2	SCREW TRUSS HEAD 5/16-18 X .75 PH ZP
29	710530	2	SCR-MC FL HD 8-32 X .50 BRS
30	711227	2	BLT-HH 5/16-18 X .62 ST PL
31	711319	5	5/16-18 HEX NUT
32	711420	1	NUT- HEX JAM 5/16-18 ST PL
33	711503	3	WSR, FLAT#10
34	711504	3	WSR-FLAT 1/4 ID SS
35	711505	2	WSR-FLAT 1/4
36	711506	2	WSR-FLT .344 X .690 X .062 STL ZINC
37	711519	2	WSR- FLAT .25 X 1.01 X .06
38	711543	3	WSR - HELICAL #10
39	711544	6	WSR-HELICAL 1/4
40	711545	2	WSR-HELICAL 5/16
41	712516	6	SCR-BHCS #8-32 x .62 SS
42	712541	3	SCR-MC 1/4-20 X 1.00 TH SS
43	712758	5	WSR-HELICAL 1/4 SS
44	712767	3	FLAT WASHER .406 ID X .75 OD X .
45	712811	3	SCR-MC RD HD 10-24 X .50 ST PL
46	712822	5	SCR-MC TR HD 10-24 X .50 SS
47	742772-1	1	VACUUM ASSEMBLY, SCV
48	748199	1	WIRE ASSY, RECOVERY TANK-VAC
49	760286	1	HOOK, WIRE FORMED
50	760343	1	TUBE, HOSE - 24/32B
51	760859	1	CLAMP, HOSE
52	830082	1	HOSE CLAMP 3/8
53	833191	1	HOSE RUBBER FLEX 2 X 9
54	833316	1	DRAIN PLUG
55	281003E	1	RECOVERY TANK - 2800

RECOVERY TANK II

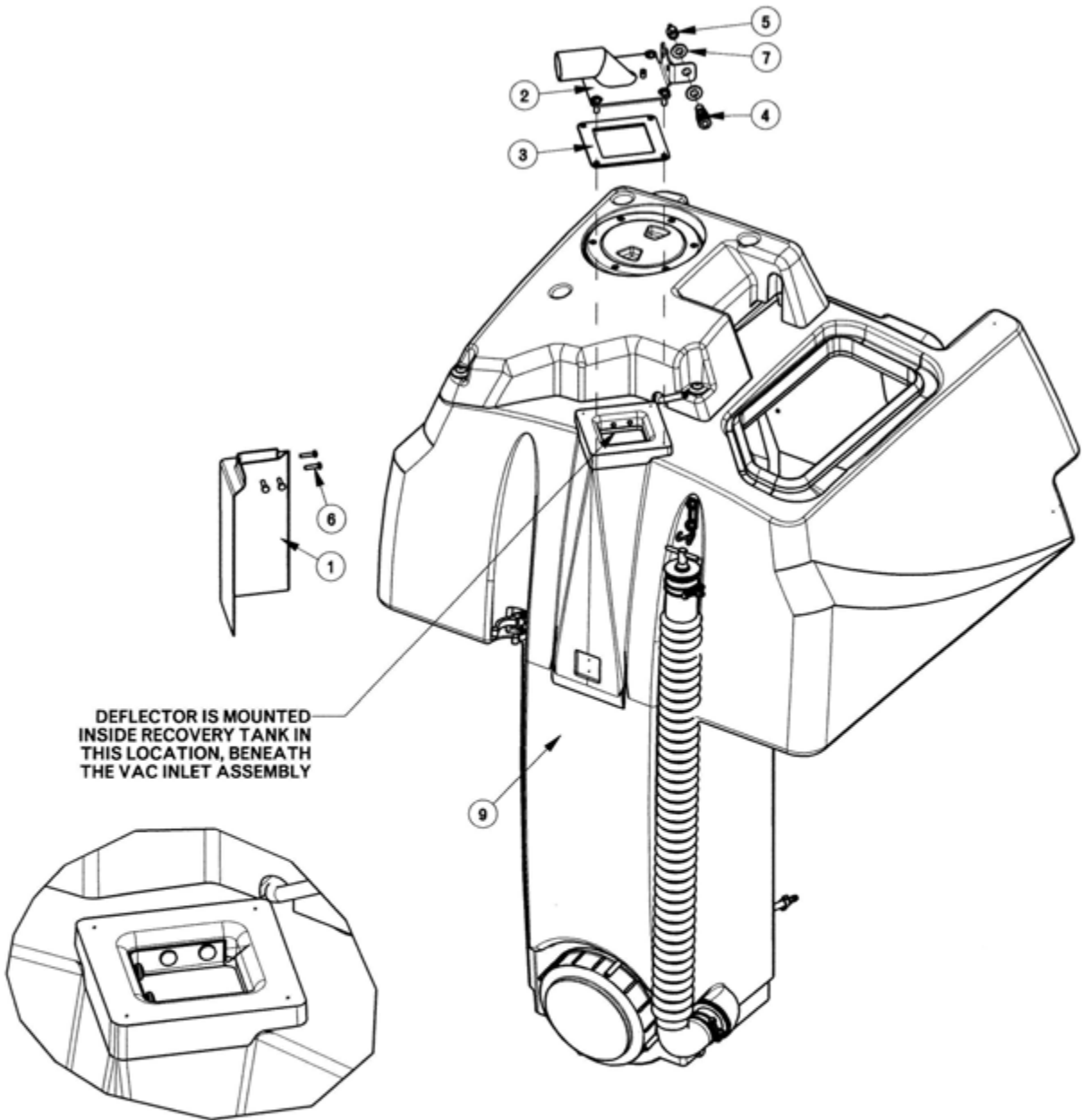

BILL OF MATERIAL - 281010E			
ITEM	PART NO.	REQ'D	DESCRIPTION
1	281019	1	DEFLECTOR
2	281490	1	VAC INLET WMT, SCV2832
3	281951	1	VAC INLET GASKET
4	450221	1	Q.C. COUPLING (FEMALE)
5	450223	1	FITTING BRASS 1/8 FPT - 1/8 BARB
6	711161	4	SCR-HI/LO 10 X 3/4 STL BLK ZINC
7	711515	2	WSR-FLAT .406 X .812 X .0625
8	748199	1	WIRE ASSY, RECOVERY TANK-VAC
9	281003E	1	RECOVERY TANK - 2800

BATTERY BOX ASSEMBLY W/ REAR BUMPER - SBG

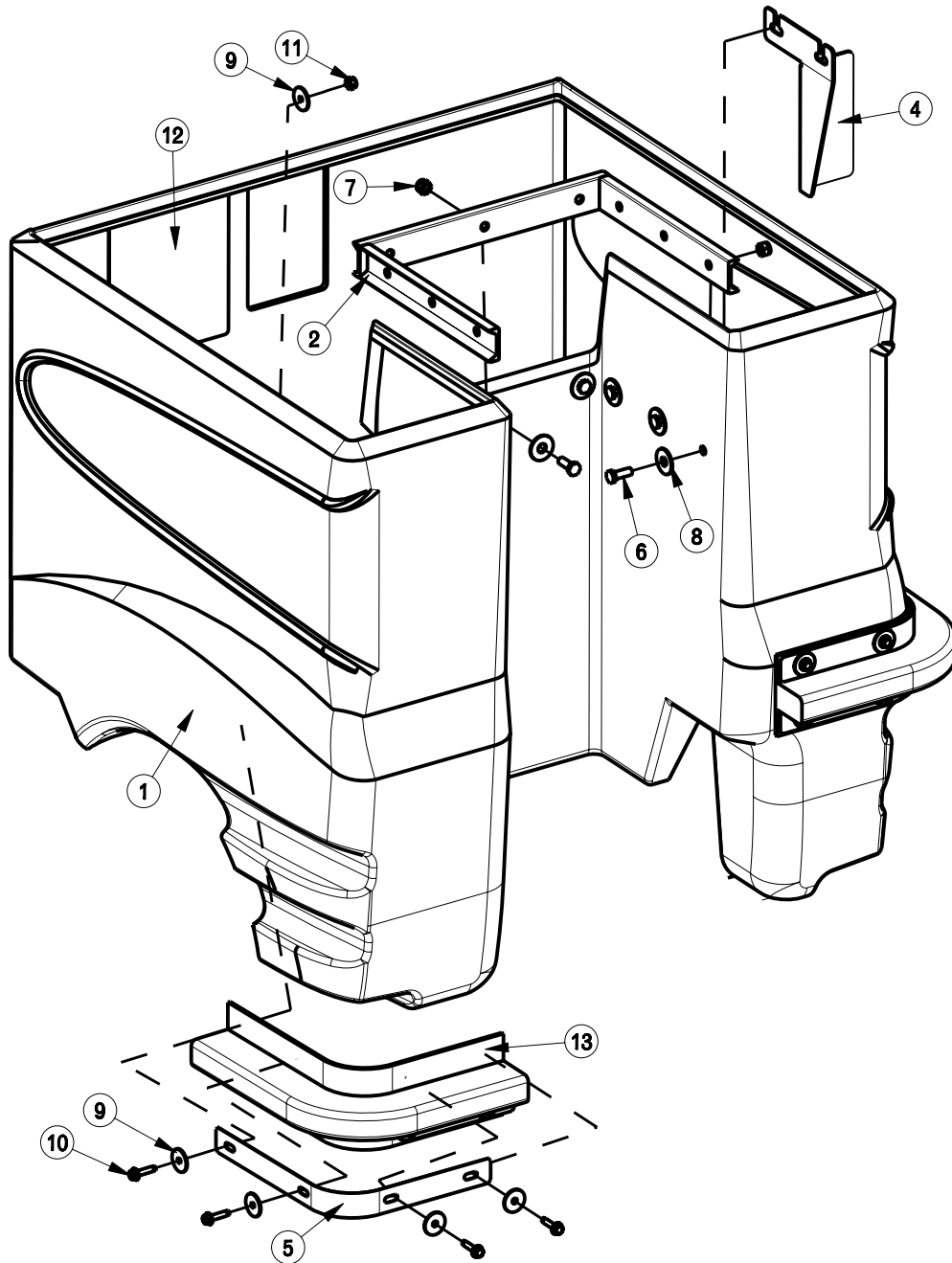

BILL OF MATERIALS - 281014 W/ REAR BUMPER			
ITEM	PART NO.	REQ'D	DESCRIPTION
1	281004	1	BATTERY TRAY - 2800
2	281059	1	BATTERY BOX STIFFENER WMT
3	281671	2	BRACKET, U CHANNEL SPACER
4	281672	2	BKT, BATTERY STOP, SCV2832
5	281773	4	STRAP - BUMPER, REAR, SCV 28/32
6	711229	9	BLT-HH 5/16-18 x .875
7	711374	9	NUT-NYLOC 5/16-18
8	711507	9	WSR-FLAT .37 X 1.12 X .06
9	711519	32	WSR- FLAT .25 X 1.01 X .06
10	712129	16	SCR-TR 1/4-20X 1.00 HWH
11	712667	16	NUT, HEX 1/4-20 NYLOC SS
12	715902E	1	DECAL, SCV ECO BATTERY
13	281796	2	RUBBER BUMPER - REAR, SCV 32, W/HCLAS

PUMP ASSEMBLY

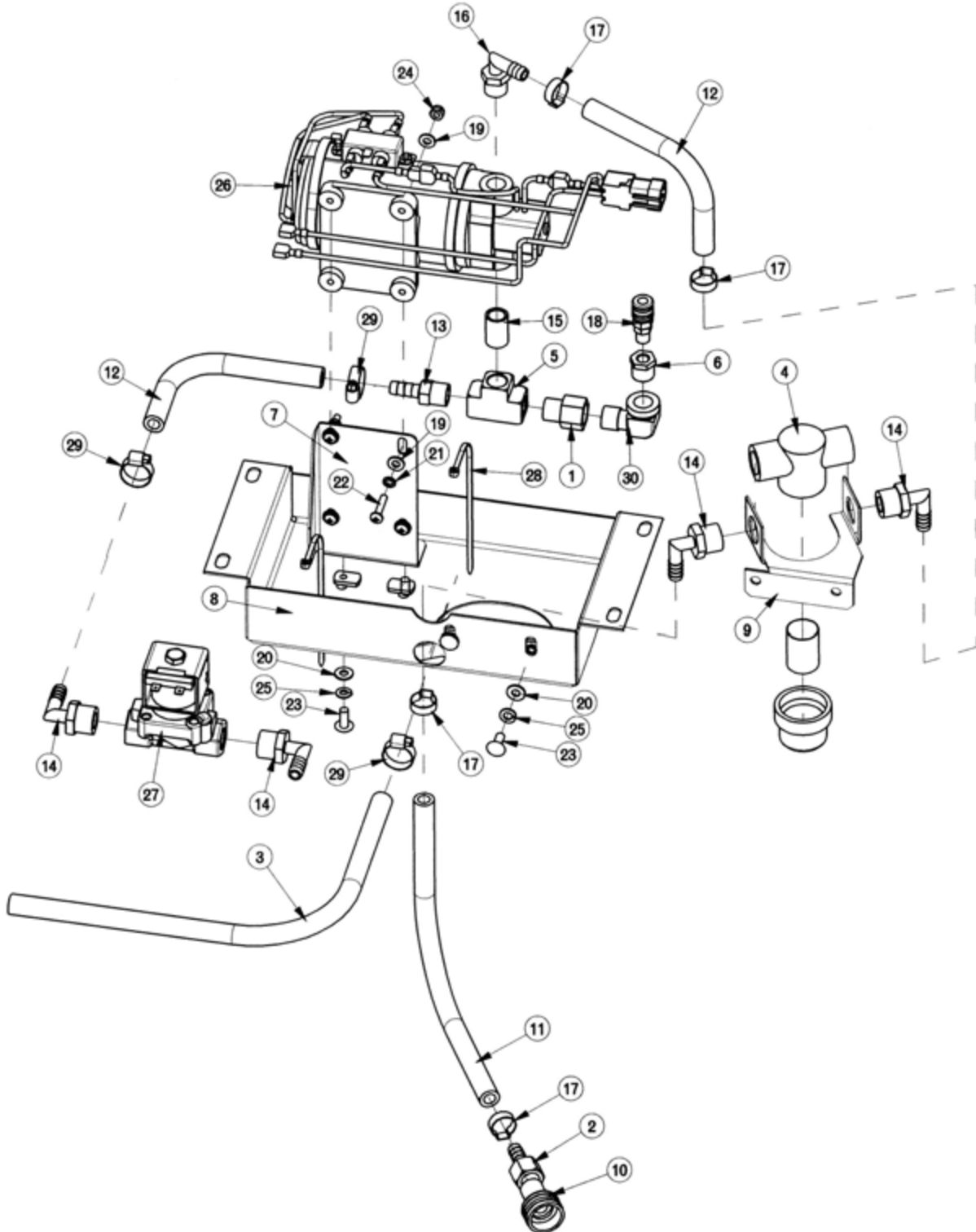

PUMP ASSEMBLY BOM

BILL OF MATERIAL - 281098E			
ITEM	PART NO.	REQ'D	DESCRIPTION
1	210409	1	FITTING ADAPTOR 3/8MPTx38/FPT BR
2	210410	1	FITTING BRASS 3/8" FPT X 3/8" BARB
3	241097	1	HOSE 3/8 x 31 WIRE REINFORCED, SCV 24/26
4	281089	1	FILTER, IN-LINE
5	281090	1	FITTING BRASS 3/8" FPT TEE
6	281091	1	FITTING 3/8MPTx1/8 FPT REDUCER
7	281368	1	PUMP MOUNT PLATE
8	281369	1	PUMP SUPPORT PLATE
9	281388	1	PUMP MTG PLATE
10	281425	1	SWIVEL CONNECTOR - 3/4" GHT X 3/8" MPT
11	320251	1	HOSE 3/8 x 12 WIRE REINFORCED
12	320254	2	HOSE 3/8 x 9.00" WIRE REINFORCED
13	342430	1	FITTING BRASS 3/8BARB 3/8 HOSE
14	383327	4	ELBOW 1/2 MPT X 3/8 BARB
15	383332	1	FITTING BRASS 3/8 NIPPLE
16	450040	1	FITTING 90 3/8 MPT X 3/8 BARB
17	450076	4	CRIMP CLAMP SS 185R
18	450221	1	Q.C. COUPLING (FEMALE)
19	711503	8	WSR, FLAT#10
20	711504	4	WSR-FLAT 1/4 ID SS
21	711553	4	WSR- INTERNAL LOCK #10
22	712531	4	SCR-MC 10-24 X 1.00 SS
23	712565	4	SCR-MC 1/4-20X.63 SS TR HD
24	712638	4	NUT, HEX 10-24 SS NYLOC
25	712758	4	WSR-HELICAL 1/4 SS
26	742709-2	1	PUMP ASSEMBLY-SCV
27	742718-1	1	SOLENOID VALVE 36V
28	828062	2	CABLE TIE .05 x .14 x 8"
29	829129	3	HOSE CLAMP MICRO-SEAL
30	830062	1	FITTING 90 STREET ELBOW 3/8x3/8

REAR AXLE ASSEMBLY - SBG

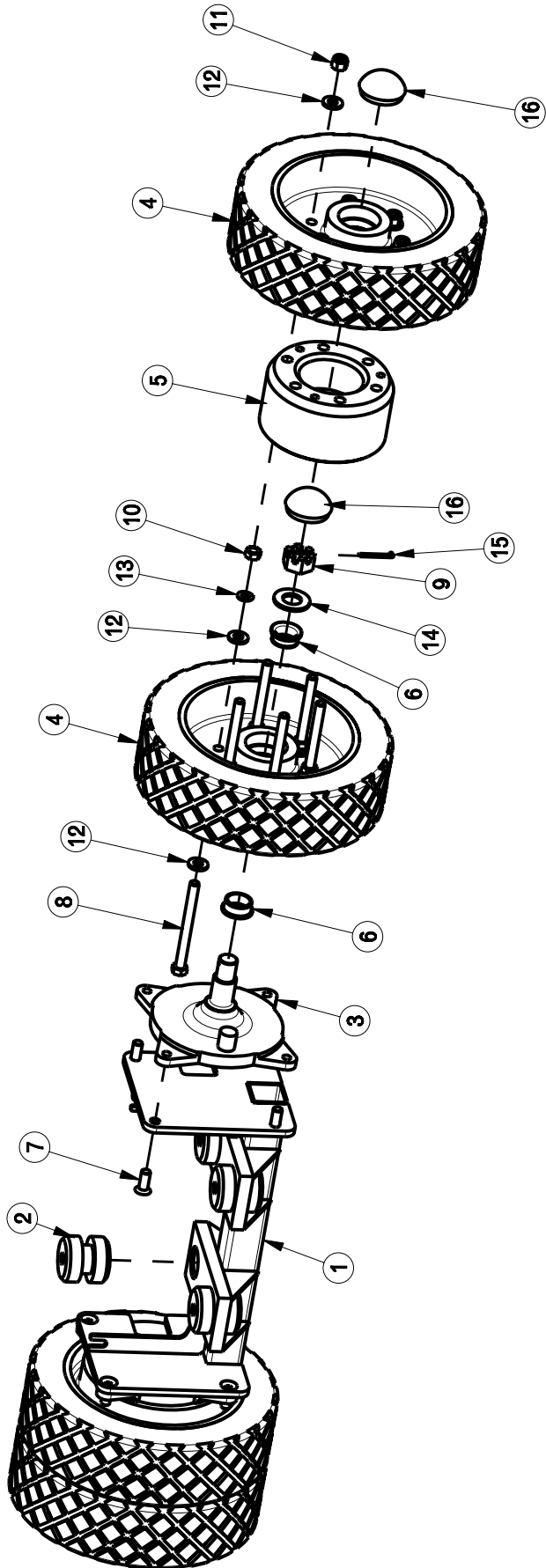

SQUEEGEE MECHANISM ASSEMBLY

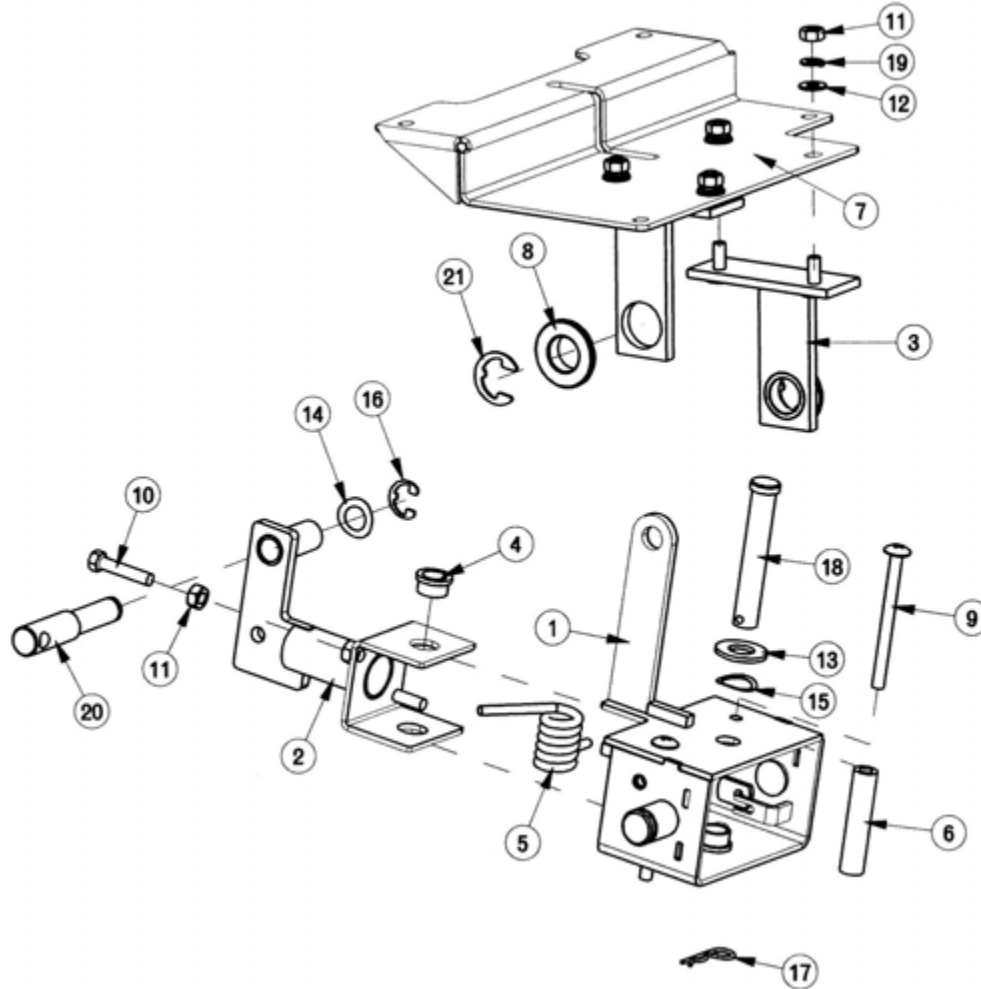

BILL OF MATERIAL - 241735			
ITEM	PART NO.	REQ'D	DESCRIPTION
1	241729	1	SQ YOKE BRKT WMNT SUB-ASSY
2	241731	1	REAR SQUEEGEE YOKE
3	241736	2	SQUEEGEE MECH ATTACHM'T WMNT
4	260041	2	OILITE FLANGE BUSHING
5	281064	1	TORSION SPRING
6	281715	2	MECHANISM STOP TUBE
7	281717	1	SQUEEGEE MECHANISM ATTACHMENT PLATE
8	320209	2	OILITE FLANGED BEARING
9	710592	2	SCR-MC 1/4-20 X 3.00 SS TH
10	711210	2	BLT-HH 1/4-20 X 1.25 STPL
11	711316	6	NUT-HEX 1/4-20 ST PL
12	711504	4	WSR-FLAT 1/4 ID SS
13	711509	1	WSR-FLAT 1/2 (.54X1.082X.087)
14	711524	1	WSR-WAVE .52 X .87 X .01
15	711525	1	WSR WAVE .65 x .86 x .01
16	711713	1	RETAINING RING - "E" TYPE EXT .500
17	711808	1	COTTER PIN-HAIR #13
18	712134	1	CLEVIS PIN, 1/2 x 3.00
19	712758	4	WSR-HELICAL 1/4 SS
20	762004	1	PIN, ADJUSTING
21	809148	2	RETAINING RING - "E" TYPE EXT .75

28" REAR SQUEEGEE ASSEMBLY

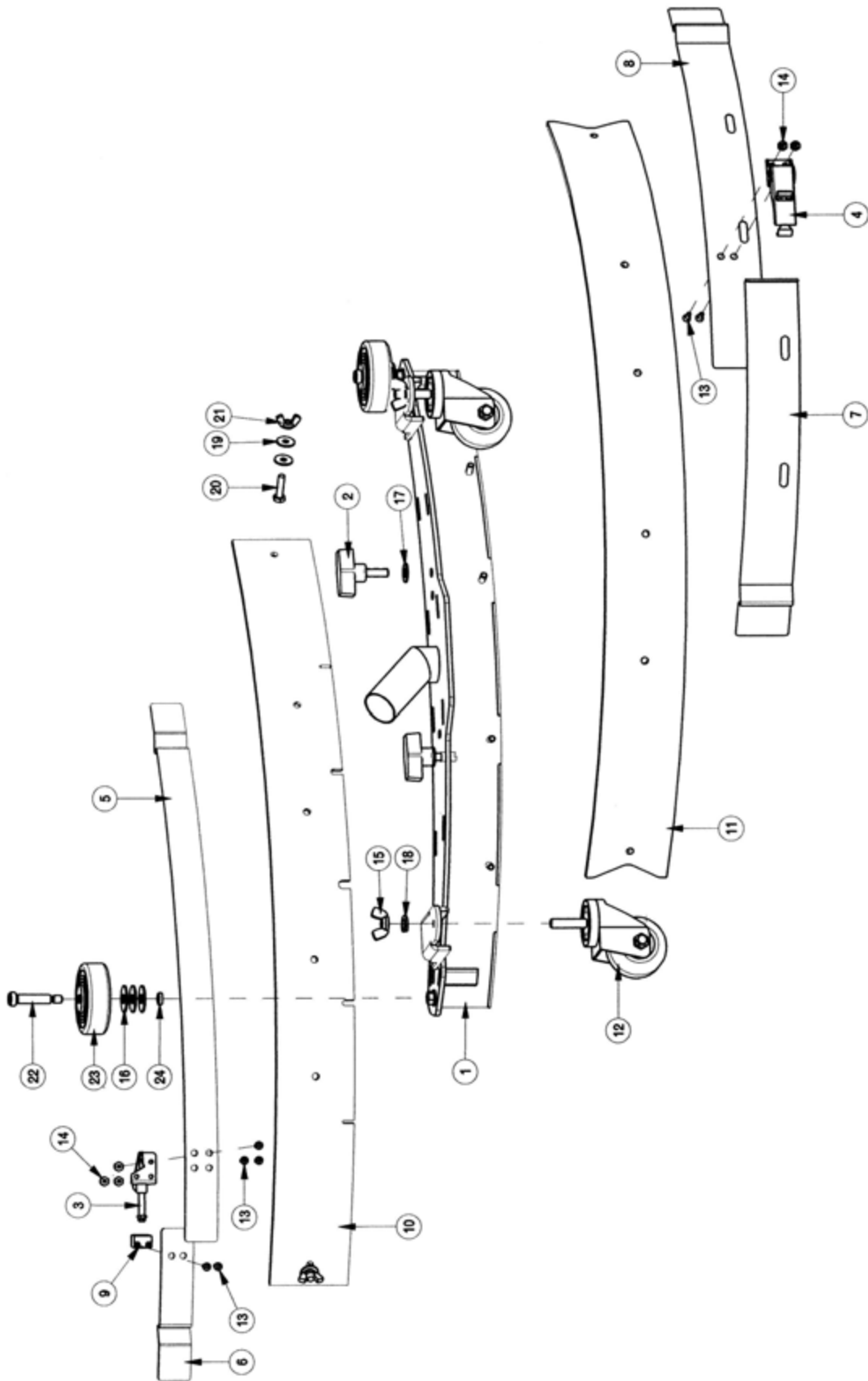

28" REAR SQUEEGEE ASSEMBLY BOM

BILL OF MATERIAL - 241740			
ITEM	PART NO.	REQ'D	DESCRIPTION
1	241721	1	SQUEEGEE WMT ASS'Y, SCV 24/26
2	241745	2	WING BOLT 3/8-16 X 1.00
3	281074	1	SQUEEGEE TOGGLE CLAMP, 2800
4	281075	1	SQUEEGEE LATCH, 2800
5	281732	1	STRAP - FRONT CLAMP
6	281734	1	STRAP - FRONT STOP
7	281736	1	STRAP - REAR CATCH
8	281738	1	STRAP - REAR LATCH
9	281740	1	STOP BAR
10	281763	1	PB FRONT BLADE,SQUEE GUM RUBBER
11	281764	1	PB REAR BLADE, SQUEEGEE GUM RUBBER
12	430325	2	CASTER 3/8"-16 X 1.50"
13	710530	7	SCR-MC FL HD 8-32 X .50 BRS
14	711026	5	NUT, HEX 8-32 NYLOC SS
15	711367	2	NUT- WING 3/8-16 ST PL
16	711507	6	WSR-FLAT .37 X 1.12 X .06
17	711515	2	WSR-FLAT .406 X .812 X .0625
18	711546	2	WSR-HELICAL 3/8
19	711550	4	WSR NYLON .25 ID X .75 OD
20	711560	2	SCREW-HH 1/4-20X1.00 NYLON
21	711563	2	NUT- WING 1/4-20 NYLON
22	712091	2	SHOULDER BLT 3/8 X 1.50
23	808829	2	WHEEL,TRUCK
24	832015	2	SPACER .38 X .50 X .140

32" REAR SQUEEGEE ASSEMBLY - SBG

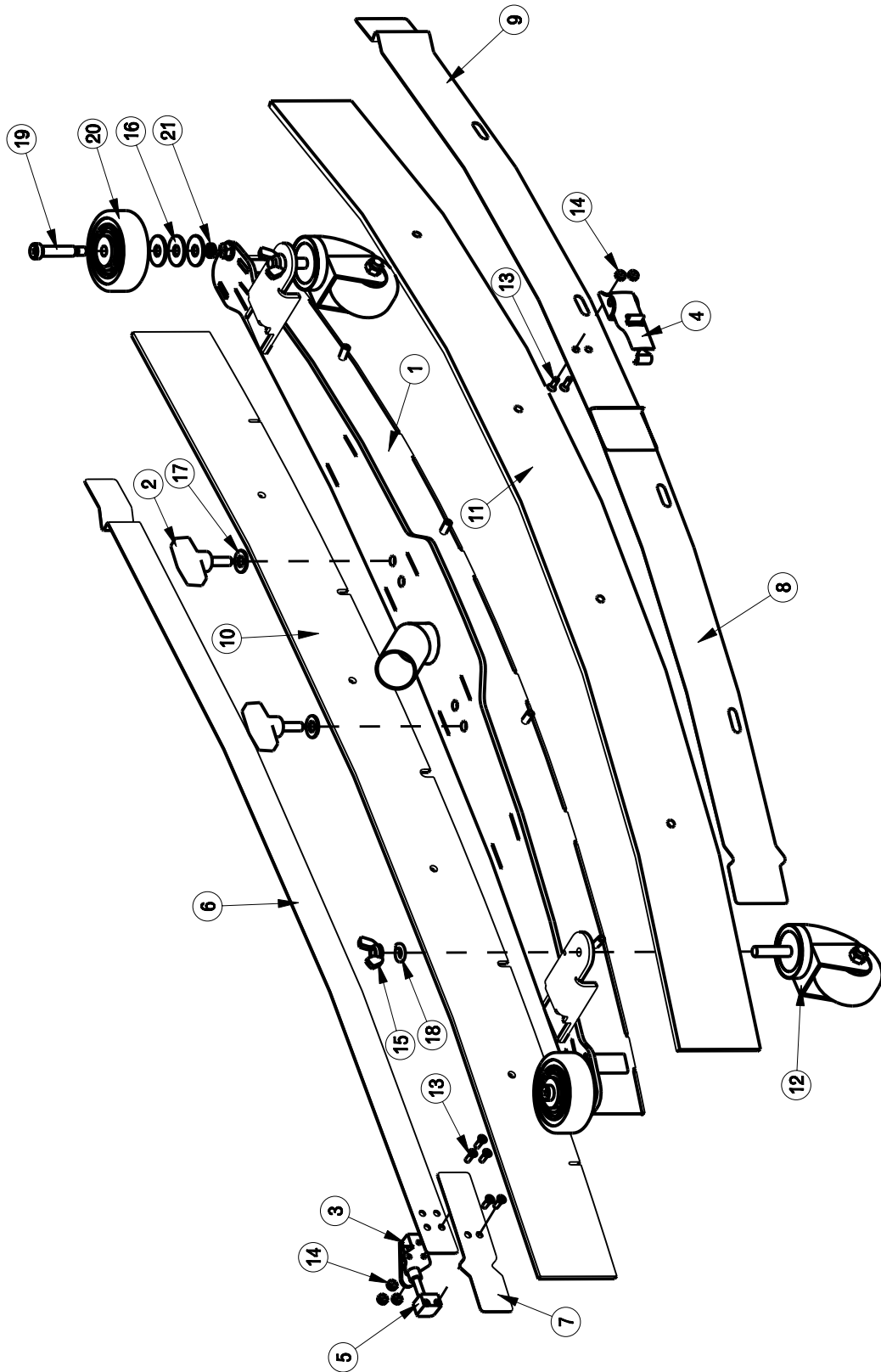

SBG 32" REAR SQUEEGEE BOM

BILL OF MATERIAL - 281579 - SBG			
ITEM	PART NO.	REQ'D	DESCRIPTION
1	241743-SBG	1	SQUEEGEE WMT ASSY, 32" SBG
2	241745	2	WING BOLT 3/8-16 X 1.00
3	281074	1	SQUEEGEE TOGGLE CLAMP, 2800
4	281075	1	SQUEEGEE LATCH, 2800
5	281740	1	STOP BAR
6	281781-SBG	1	STRAP - FRONT CLAMP, 32" SBG
7	281782	1	STRAP - FRONT STOP, 32"
8	281783-SBG	1	STRAP - REAR CATCH, 32" SBG
9	281784-SBG	1	STRAP - REAR LATCH, 32" SBG
10	281785-SBG	1	FRONT BLADE, SQUEEGEE LINATEX, 32" SBG
11	281786-SBG	1	REAR BLADE, SQUEEGEE LINATEX, 32" SBG
12	430325	2	CASTER 3/8"-16 X 1.50"
13	710530	7	SCR-MC FL HD 8-32 X .50 BRS
14	711026	5	NUT, HEX 8-32 NYLOC SS
15	711367	2	NUT- WING 3/8-16 ST PL
16	711507	6	WSR-FLAT .37 X 1.12 X .06
17	711515	2	WSR-FLAT .406 X .812 X .0625
18	711546	2	WSR-HELICAL 3/8
19	712091	2	SHOULDER BLT 3/8 X 1.50
20	808829	2	WHEEL, TRUCK
21	832015	2	SPACER .38 X .50 X .140

SQUEEGEE LIFT MECHANISM

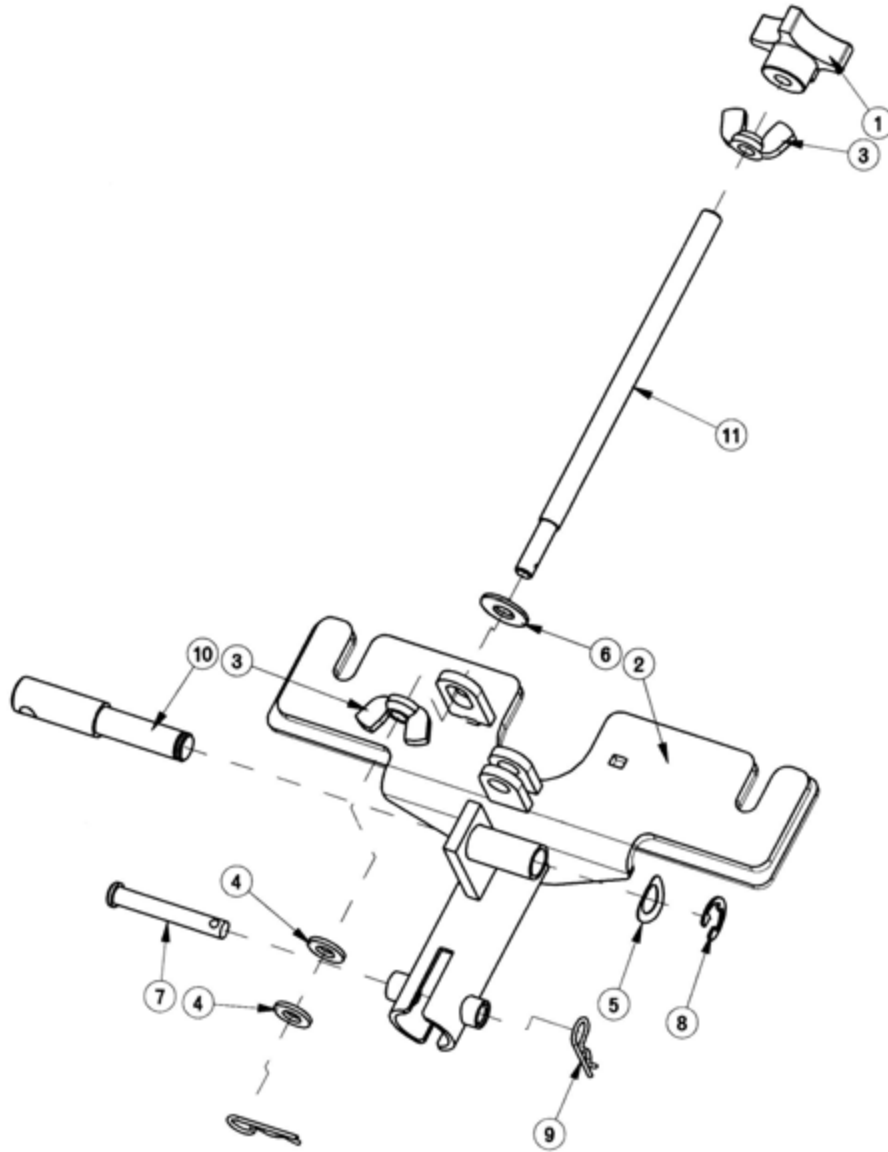

BILL OF MATERIAL			
ITEM	PART NO.	REQ'D	DESCRIPTION
1	241057	1	KNOB, 3/8-16 X 1-3/4 FOUR PRONG.
2	241751-1	1	REAR SQUEEGEE MOUNT PLATE WMNT, SCV 24/26
3	711367	2	NUT- WING 3/8-16 ST PL
4	711506	2	WSR-FLT .344 X .690 X .062 STL ZINC
5	711524	1	WSR-WAVE .52 X .87 X .01
6	711569	1	WSR-FLT .390 X .880 X .062 NYL
7	711671	1	CLEVIS PIN .31X2.13 11-10
8	711713	1	RETAINING RING - "E" TYPE EXT .500
9	711808	2	COTTER PIN-HAIR #13
10	762005	1	ADJUSTING PIN, THREADED
11	762006	1	THREADED ROD, 3/8-16 X 7.5" LG

28" CYLINDRICAL SCRUBDECK

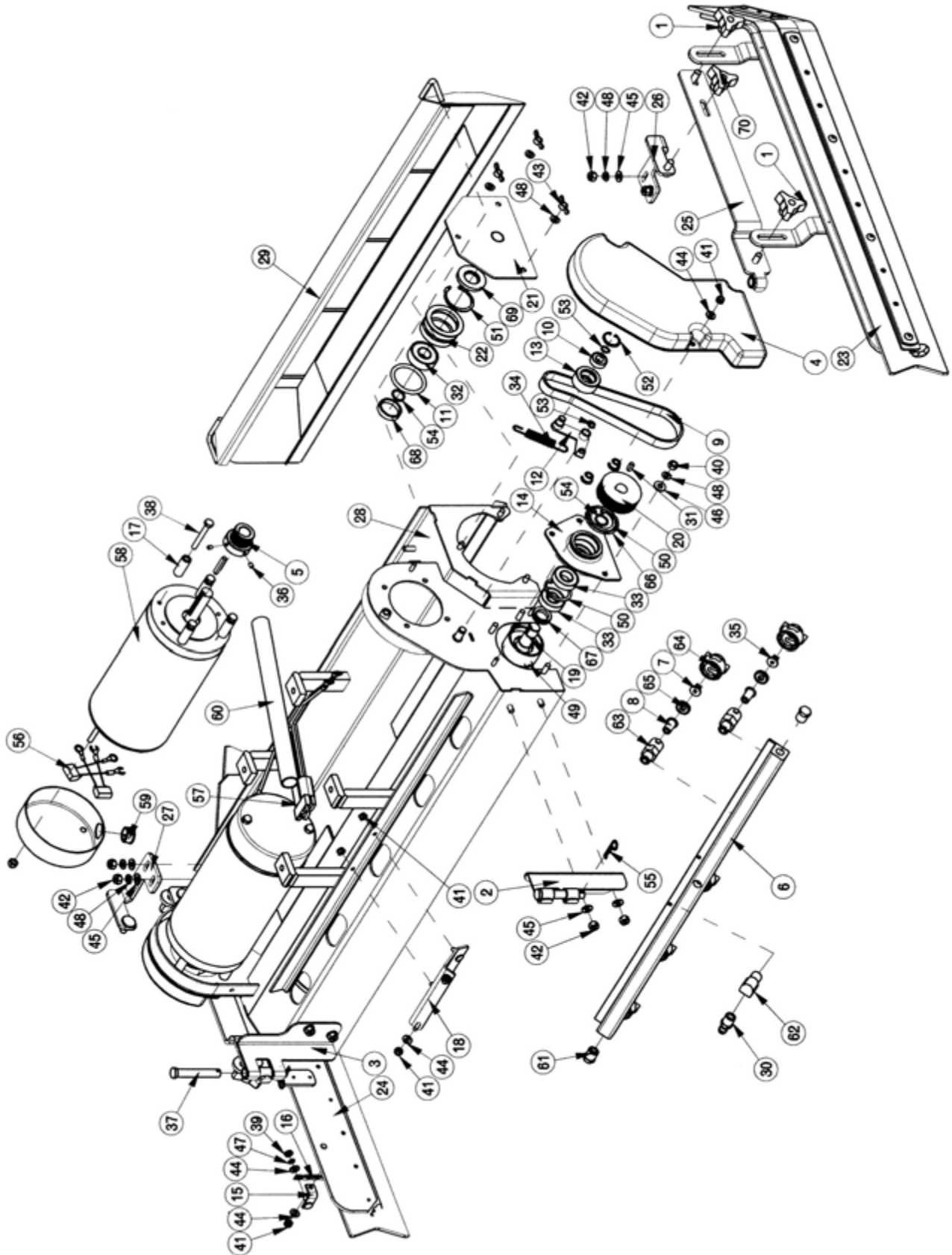

28" CYLINDRICAL SCRUBDECK BOM

BILL OF MATERIAL				BILL OF MATERIAL			
ITEM	PART NO.	REQ'D	DESCRIPTION	ITEM	PART NO.	REQ'D	DESCRIPTION
1	210118	4	KNOB-3 SIDED 5/16 NYLOC	36	711003	8	SCR-SK 10-32 x .25
2	241544	1	HINGE BRKT WLDMNT RH, SCV2426	37	711119	2	CLEVIS PIN 7/16 X 2-5/8
3	241546	1	HINGE BRKT WLDMNT LH, SCV2426	38	711214	8	BLT-HH 1/4-20 X 2.00
4	281023	2	BELT COVER, CYLINDRICAL SCRUBDECK	39	711310	1	NUT, HEX 10-32 ST PL
5	281036	2	OFFSET PULLEY POLY V	40	711316	8	NUT-HEX 1/4-20 ST PL
6	281038	1	SPRAY BAR	41	711350	10	NUT-NYLOC 10-32
7	281040	3	SPRAY TIP 11005	42	711373	8	NUT-NYLOC 1/4-20
8	281041	5	CHECK VALVE	43	711389	6	NUT-WING 1/4-20 STL ZINC
9	281053	2	J BELT (POLY V) 18"	44	711503	9	WSR, FLAT#10
10	281058	2	BEARING 3/8" RADIAL	45	711504	8	WSR-FLAT 1/4 ID SS
11	281519	2	O-RING 1.62 X 2.00 X .188	46	711505	6	WSR-FLAT 1/4
12	281544	2	TENSIONER ARM WELDMT	47	711543	1	WSR - HELICAL #10
13	281548	2	BELT IDLER	48	711544	16	WSR-HELICAL 1/4
14	281550	2	BEARING HOUSING, CYL SCRUBDECK	49	711676	4	ROLL PIN, 3/8 x 3/4
15	281557	1	DRAG CHAIN BRKT, CYL. SCRUBDECK	50	711701	4	RETAINING RING, INT 1.37
16	281558	1	DRAG CHAIN, CYL. SCRUBDECK	51	711702	2	RETAINING RING, INT 1.62
17	281598	8	MOTOR STANDOFF - CYL SCRUB DECK	52	711704	2	INT RETAINING RING N5000-86 .875 DIA.
18	281606	1	SPRAY HEAD MTG BRKT	53	711724	4	3/8" RETAINING RING, EXTERNAL
19	281675	2	DRIVE HUB, CYL SCRUBDECK	54	711725	4	5/8" RETAINING RING, EXTERNAL
20	281676	2	DRIVEN PULLEY, CYL SCRUBDECK	55	711808	2	COTTER PIN-HAIR #13
21	281681	2	IDLE SHAFT WMT, CYL DECK	56	744016-1	4	CAP .15 MICROFARAD 5/16R-1/4FORK
22	281684	2	IDLE HUB, CYL SCRUBDECK	57	748046	1	WIRE ASSY, BRUSH DECK CYLINDER
23	281851	1	SIDE SQUEEGEE WIPE ASSY LH, SCV 28/32	58	748048	2	MOTOR 1 HP, 36V, 1800RPM
24	281857	1	SIDE SQUEEGEE WIPE ASSY RH, SCV 28/32	59	748122	2	BUSHING, HEYCO 2103 I.D. .625.
25	281866	2	UPPER SQUEEE BRKT WMT, SCV 28/32	60	748141	1	CABLE WRAP, 1"
26	281868	1	CYL. DECK SIDE SQUEE SUPPORT LH	61	829619	2	END PLUG
27	281869	1	CYL. DECK SIDE SQUEE SUPPORT RH	62	831306	1	FITTING 90 STREET BRASS 1/4x1/4
28	281832	1	28" CYLINDRICAL SCRUBDECK WELDMNT	63	833140	5	BODY INLET CONNECTOR
29	281901	1	DEBRIS BOX WMT, CYL SCRUBDECK 28"	64	833141	5	CAP
30	320264	1	FITTING BRASS - 3/8 DBL BARB X 1/4MPT	65	833142	5	GASKET CAP
31	361252	2	KEY, WOODRUFF, 3/16 SQ X .5	66	833603	2	O RING, 1 11/16 x 1 7/8, AS568A-131
32	383551	2	BEARING, RADIAL 5/8" 6203	67	833605	2	V-RING SEAL
33	383558	4	BEARING, RADIAL 5/8" R10	68	833611	2	END CAP
34	430051	2	RETURN SPRING-3.00"	69	833612	2	RADIAL SHAFT SEAL
35	450122	2	UNIJET SPRAY TIP 6503	70	210118Y	2	KNOB-3 SIDED 5/16 NYLOC YELLOW

32" CYLINDRICAL SCRUBDECK

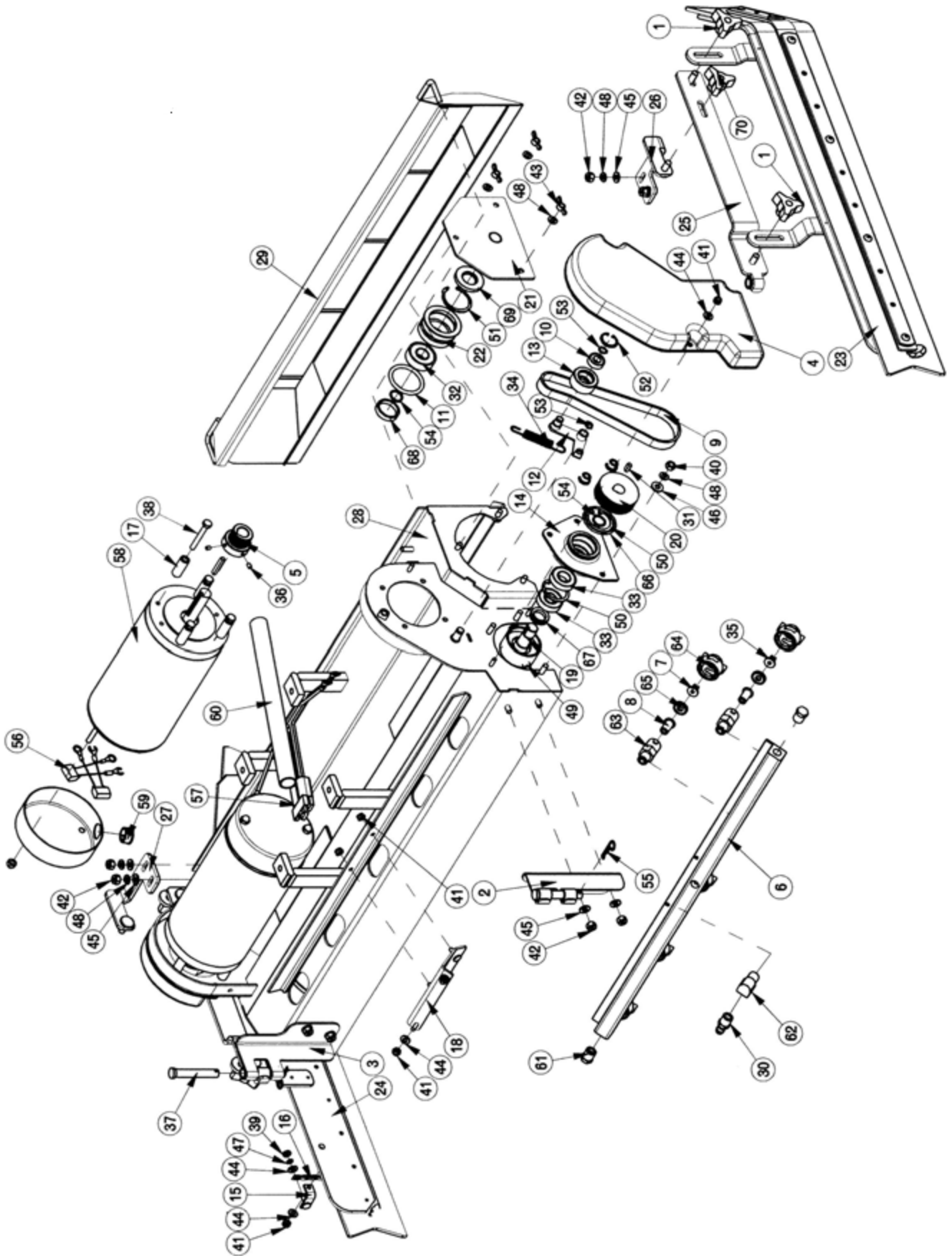

32" CYLINDRICAL SCRUBDECK BOM

BILL OF MATERIAL				BILL OF MATERIAL			
ITEM	PART NO.	REQ'D	DESCRIPTION	ITEM	PART NO.	REQ'D	DESCRIPTION
1	210118	4	KNOB-3 SIDED 5/16 NYLOC	36	711003	8	SCR-SK 10-32 x .25
2	241544	1	HINGE BRKT WLDMNT RH, SCV2426	37	711119	2	CLEVIS PIN 7/16 X 2-5/8
3	241546	1	HINGE BRKT WLDMNT LH, SCV2426	38	711214	8	BLT-HH 1/4-20 X 2.00
4	281023	2	BELT COVER, CYLINDRICAL SCRUBDECK	39	711310	1	NUT, HEX 10-32 ST PL
5	281036	2	OFFSET PULLEY POLY V	40	711316	8	NUT-HEX 1/4-20 ST PL
6	281038	1	SPRAY BAR	41	711350	10	NUT-NYLOC 10-32
7	281040	3	SPRAY TIP 11005	42	711373	8	NUT-NYLOC 1/4-20
8	281041	5	CHECK VALVE	43	711389	6	NUT-WING 1/4-20 STL ZINC
9	281053	2	J BELT (POLY V) 18"	44	711503	9	WSR, FLAT#10
10	281058	2	BEARING 3/8" RADIAL	45	711504	8	WSR-FLAT 1/4 ID SS
11	281519	2	O-RING 1.62 X 2.00 X .188	46	711505	6	WSR-FLAT 1/4
12	281544	2	TENSIONER ARM WELDMT	47	711543	1	WSR - HELICAL #10
13	281548	2	BELT IDLER	48	711544	16	WSR-HELICAL 1/4
14	281550	2	BEARING HOUSING, CYL SCRUBDECK	49	711676	4	ROLL PIN, 3/8 x 3/4
15	281557	1	DRAG CHAIN BRKT, CYL. SCRUBDECK	50	711701	4	RETAINING RING, INT 1.37
16	281558	1	DRAG CHAIN, CYL. SCRUBDECK	51	711702	2	RETAINING RING, INT 1.62
17	281598	8	MOTOR STANDOFF - CYL SCRUB DECK	52	711704	2	INT RETAINING RING N5000-86 .875 DIA.
18	281606	1	SPRAY HEAD MTG BRKT	53	711724	4	3/8" RETAINING RING, EXTERNAL
19	281675	2	DRIVE HUB, CYL SCRUBDECK	54	711725	4	5/8" RETAINING RING, EXTERNAL
20	281676	2	DRIVEN PULLEY, CYL SCRUBDECK	55	711808	2	COTTER PIN-HAIR #13
21	281681	2	IDLE SHAFT WMT, CYL DECK	56	744016-1	4	CAP .15 MICROFARAD 5/16R-1/4FORK
22	281684	2	IDLE HUB, CYL SCRUBDECK	57	748046	1	WIRE ASSY, BRUSH DECK CYLINDER
23	281851	1	SIDE SQUEEGEE WIPE ASSY LH, SCV 28/32	58	748048	2	MOTOR 1 HP, 36V, 1800RPM
24	281857	1	SIDE SQUEEGEE WIPE ASSY RH, SCV 28/32	59	748122	2	BUSHING, HEYCO 2103 I.D. .625.
25	281866	2	UPPER SQUEEE BRKT WMT, SCV 28/32	60	748141	1	CABLE WRAP, 1"
26	281868	1	CYL. DECK SIDE SQUEE SUPPORT LH	61	829619	2	END PLUG
27	281869	1	CYL. DECK SIDE SQUEE SUPPORT RH	62	831306	1	FITTING 90 STREET BRASS 1/4x1/4
28	281892	1	32" CYLINDRICAL SCRUBDECK WELDMNT	63	833140	5	BODY INLET CONNECTOR
29	281906	1	DEBRIS BOX WMT, CYL SCRUBDECK 32"	64	833141	5	CAP
30	320264	1	FITTING BRASS - 3/8 DBL BARB X 1/4MPT	65	833142	5	GASKET CAP
31	361252	2	KEY, WOODRUFF, 3/16 SQ X .5	66	833603	2	O RING, 1 11/16 x 1 7/8, AS568A-131
32	383551	2	BEARING, RADIAL 5/8" 6203	67	833605	2	V RING SEAL
33	383558	4	BEARING, RADIAL 5/8" R10	68	833611	2	END CAP
34	430051	2	RETURN SPRING-3.00"	69	833612	2	RADIAL SHAFT SEAL
35	450122	2	UNIJET SPRAY TIP 6503	70	210118Y	2	KNOB-3 SIDED 5/16 NYLOC YELLOW

28" DISK SCRUBDECK

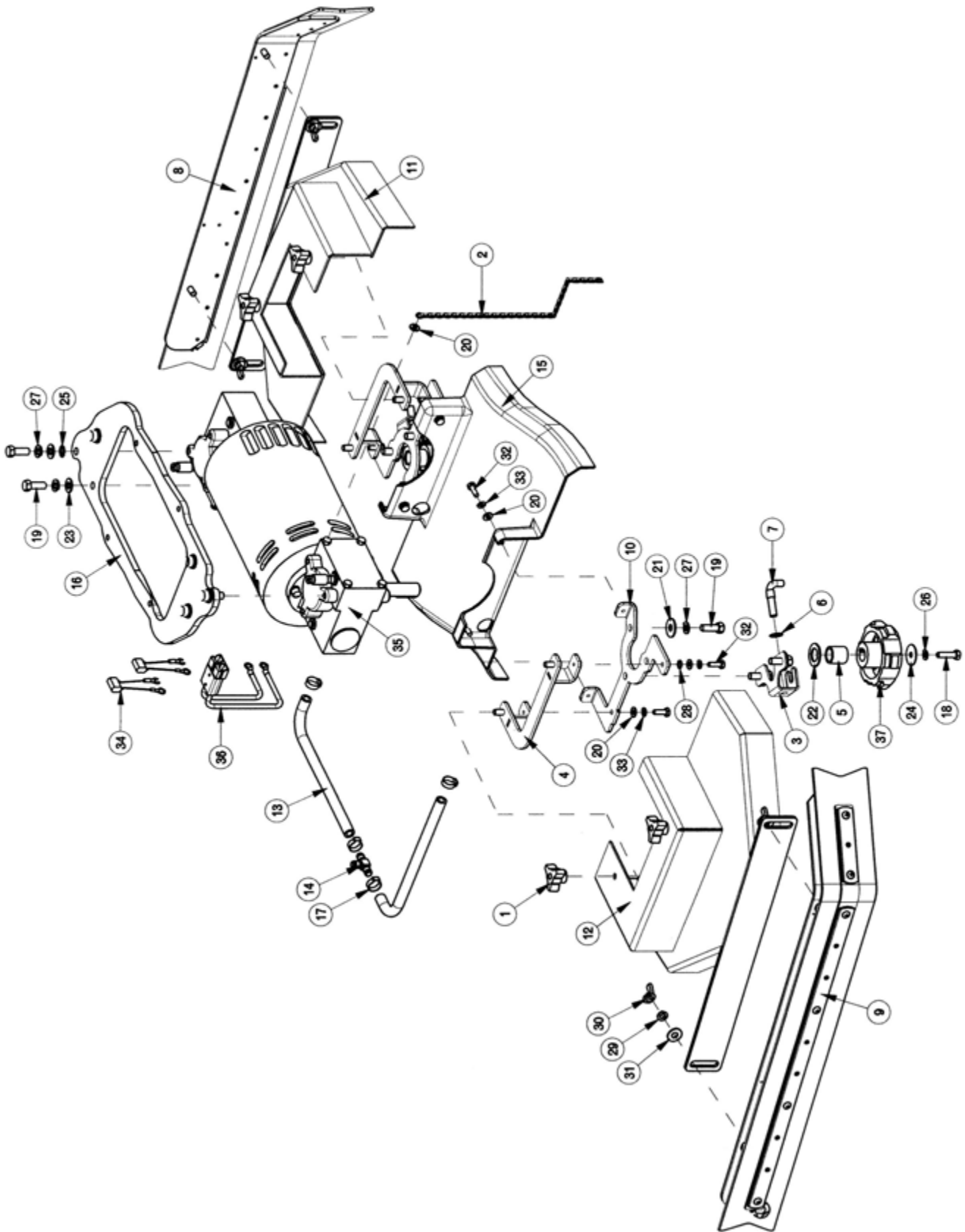

32" DISK SCRUBDECK BOM

BILL OF MATERIAL - 281884			
ITEM	PART NO.	REQ'D	DESCRIPTION
1	210118	4	KNOB-3 SIDED 5/16 NYLOC
2	241628	1	DRAG CHAIN ASSY, DISK SCRUBDECK SCV24/26
3	241653	2	WATER FEED BRKT, DISK, SCV24/26
4	241662	2	COVER MNT BRK'T, SCV 24/26 ASSY
5	281611	2	HUB-SCRUB SPACER TUBE
6	281633	2	SPEED NUT - 3/8"
7	281634	2	DISK SOLUTION FEED ASSY
8	281875	1	SIDE SQUEEGEE WIPE ASSY RH, SCV 24/26
9	281878	1	SIDE SQUEEGEE WIPE ASSY LH, SCV 24/26
10	281883	2	MOUNTING BRACKET, MOTOR COVER
11	281885	1	DISK DECK COVER RH 32", SCV 28/32
12	281887	1	DISK DECK COVER LH 32", SCV 28/32
13	320253	2	HOSE-WIRE REINF 3/8 X 14"
14	320266	1	FITTING BRASS TEE DBL 3/8 BARB
15	320857	1	DECK COVER, 32" DISK
16	320859	1	DISK SCRUBDECK MNTG PLATE, 32"
17	450076	4	CRIMP CLAMP SS 185R
18	711231	2	BLT-HH 5/16-18X1.25 ST PL
19	711242	12	BLT-HEX 3/8 -16X1.00 ZP
20	711504	9	WSR-FLAT 1/4 ID SS
21	711507	6	WSR-FLAT .37 X 1.12 X .06
22	711512	2	WSR-FLAT .75X1.37X.08
23	711515	6	WSR-FLAT .406 X .812 X .0625
24	711516	2	WSR- FLAT .31 X 1.25 X .05
25	711539	2	WSR-EXTERNAL LOCK 3/8
26	711545	2	WSR-HELICAL 5/16
27	711546	12	WSR-HELICAL 3/8
28	711554	2	WSR-INTERNAL LOCK 1/4 ID
29	712140	4	WSR-HELICAL 5/16 SS
30	712157	4	NUT- WING 5/16-18 SS
31	712301	4	WSR-FLAT .87 X .38 X .06
32	712562	8	BOLT-HH 1/4-20X3/4 SS
33	712758	8	WSR-HELICAL 1/4 SS
34	744016-1	2	CAP .15 MICROFARAD 5/16R-1/4FORK
35	748033	1	MOTOR, 32" DUAL RIGHT ANGLE
36	748077	1	WIRE ASSY, BRUSH DECK DISK
37	3312402	2	HUB-SCRUB BRUSH DRIVE

28" DISK SCRUBDECK BOM

BILL OF MATERIAL - 281870			
ITEM	PART NO.	REQ'D	DESCRIPTION
1	210118	4	KNOB-3 SIDED 5/16 NYLOC
2	241628	1	DRAG CHAIN ASSY, DISK SCRUBDECK SCV24/26
3	241653	2	WATER FEED BRKT, DISK, SCV24/26
4	241662	2	COVER MNT BRK'T, SCV 24/26 ASSY
5	281611	2	HUB-SCRUB SPACER TUBE
6	281633	2	SPEED NUT - 3/8"
7	281634	2	DISK SOLUTION FEED ASSY
8	281875	1	SIDE SQUEEGEE WIPE ASSY RH, SCV 24/26
9	281878	1	SIDE SQUEEGEE WIPE ASSY LH, SCV 24/26
10	281883	2	MOUNTING BRACKET, MOTOR COVER
11	281874	1	DISK DECK COVER RH, SCV 24/26
12	281871	1	DISK DECK COVER LH, SCV 24/26
13	320253	2	HOSE-WIRE REINF 3/8 X 14"
14	320266	1	FITTING BRASS TEE DBL 3/8 BARB
15	320928	1	DECK COVER, 28" DISK
16	320929	1	DISK SCRUBDECK MNTG PLATE, 28'
17	450076	4	CRIMP CLAMP SS 185R
18	711231	2	BLT-HH 5/16-18X1.25 ST PL
19	711242	12	BLT-HEX 3/8 -16X1.00 ZP
20	711504	5	WSR-FLAT 1/4 ID SS
21	711507	6	WSR-FLAT .37 X 1.12 X .06
22	711512	2	WSR-FLAT .75X1.37X.08
23	711515	6	WSR-FLAT .406 X .812 X .0625
24	711516	2	WSR- FLAT .31 X 1.25 X .05
25	711539	2	WSR-EXTERNAL LOCK 3/8
26	711545	2	WSR-HELICAL 5/16
27	711546	12	WSR-HELICAL 3/8
28	711554	2	WSR-INTERNAL LOCK 1/4 ID
29	712140	4	WSR-HELICAL 5/16 SS
30	712157	4	NUT- WING 5/16-18 SS
31	712301	4	WSR-FLAT .87 X .38 X .06
32	712562	4	BOLT-HH 1/4-20X3/4 SS
33	712758	4	WSR-HELICAL 1/4 SS
34	744016-1	2	CAP .15 MICROFARAD 5/16R-1/4FORK
35	748003	1	MOTOR, 28" DUAL RIGHT ANGLE DRIVE
36	748077	1	WIRE ASSY, BRUSH DECK DISK
37	3312402	2	HUB-SCRUB BRUSH DRIVE

32" DISK SCRUBDECK

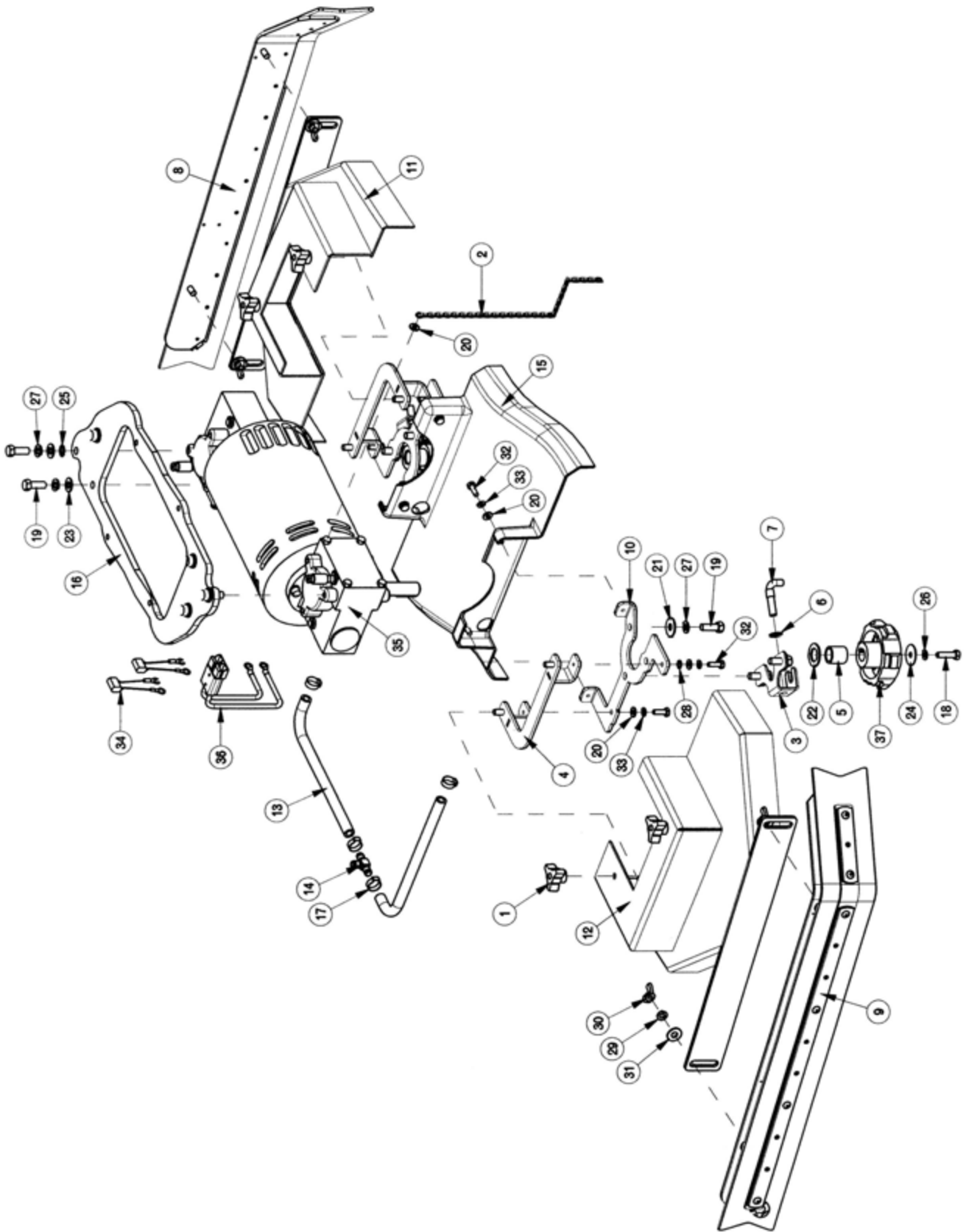

CYLINDRICAL SCRUBDECK SIDE SQUEEGEE (LEFT SIDE)

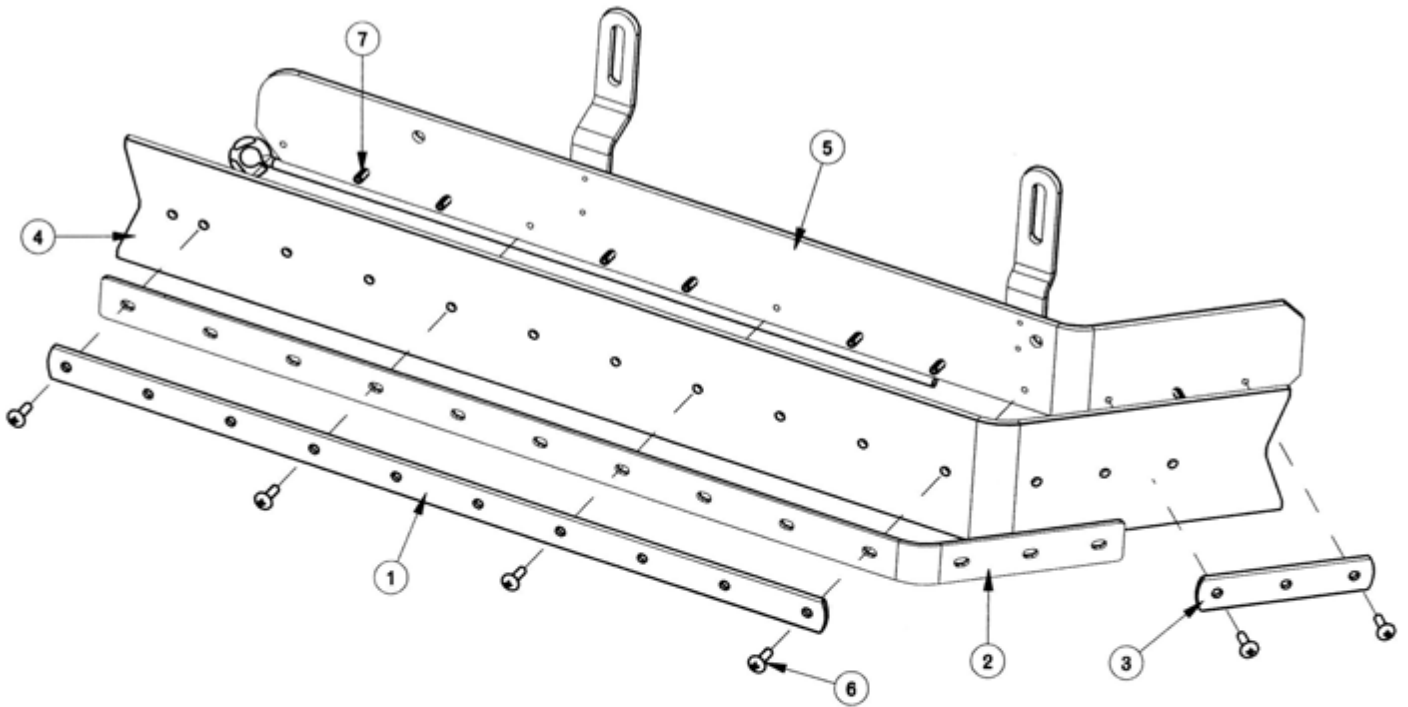

BILL OF MATERIAL - 281851			
ITEM	PART NO.	REQ'D	DESCRIPTION
1	241679	1	LONG RETAINER, SIDE SQ SCV2426
2	281855	1	BACKER BLADE, LONG SCV 2832
3	281856	1	SHORT RETAINER, SIDE SQ SCV2426
4	281859	1	SIDE SQUEEGEE BLADE LINATEX, SCV 2832
5	281860	1	DISK SQUEEGEE BRKT WMT LH, SCV 28/32
6	710154	6	SCR-MC TR HD 10-32 X .625 SS
7	711622	7	ROLL PIN 3/16" X 5/8"

CYLINDRICAL SCRUBDECK SIDE SQUEEGEE (RIGHT SIDE)

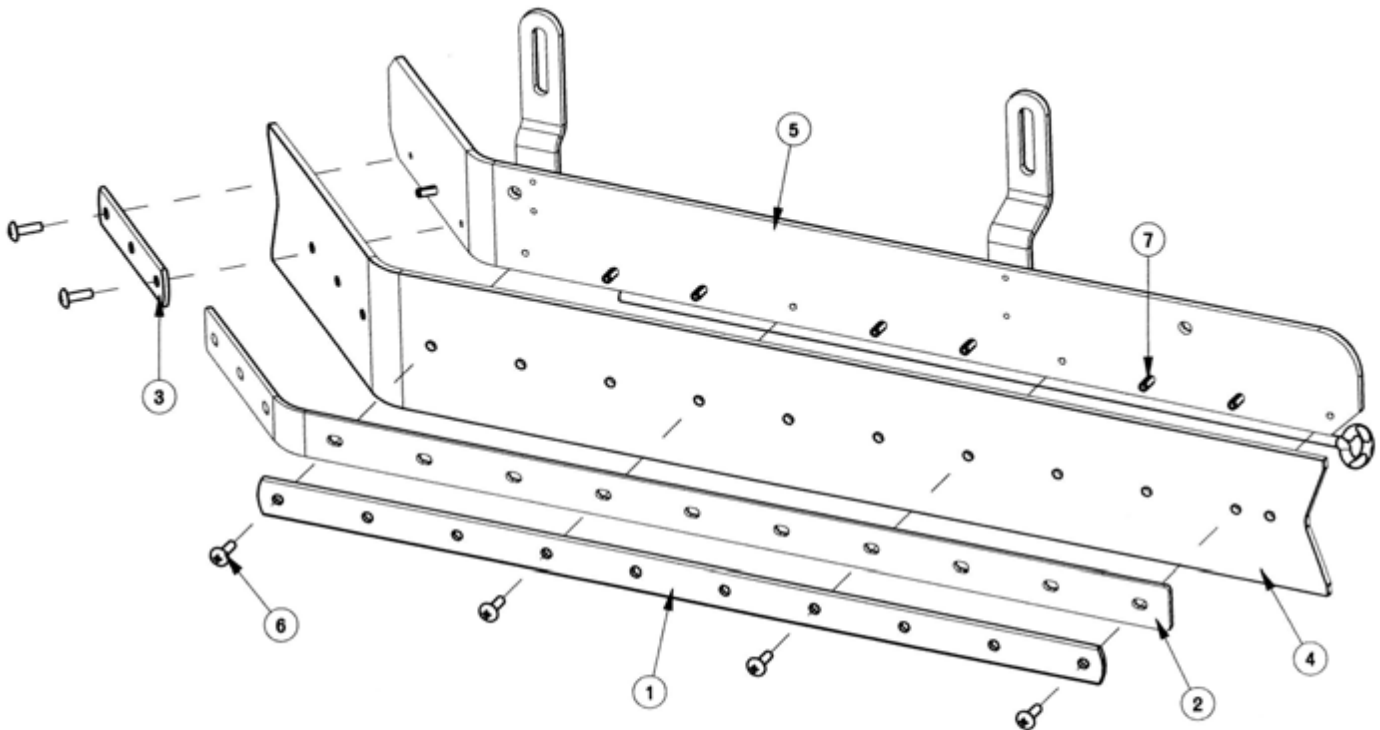

BILL OF MATERIAL - 281857			
ITEM	PART NO.	REQ'D	DESCRIPTION
1	241679	1	LONG RETAINER, SIDE SQ SCV2426
2	281855	1	BACKER BLADE, LONG SCV 2832
3	281856	1	SHORT RETAINER, SIDE SQ SCV2426
4	281859	1	SIDE SQUEEGEE BLADE LINATEX, SCV 2832
5	281864	1	SQUEEGEE BRK'T WMNT RH, SCV 28/32
6	710154	6	SCR-MC TR HD 10-32 X .625 SS
7	711622	7	ROLL PIN 3/16" X 5/8"

DISK SCRUBDECK SIDE SQUEEGEE (LEFT SIDE)

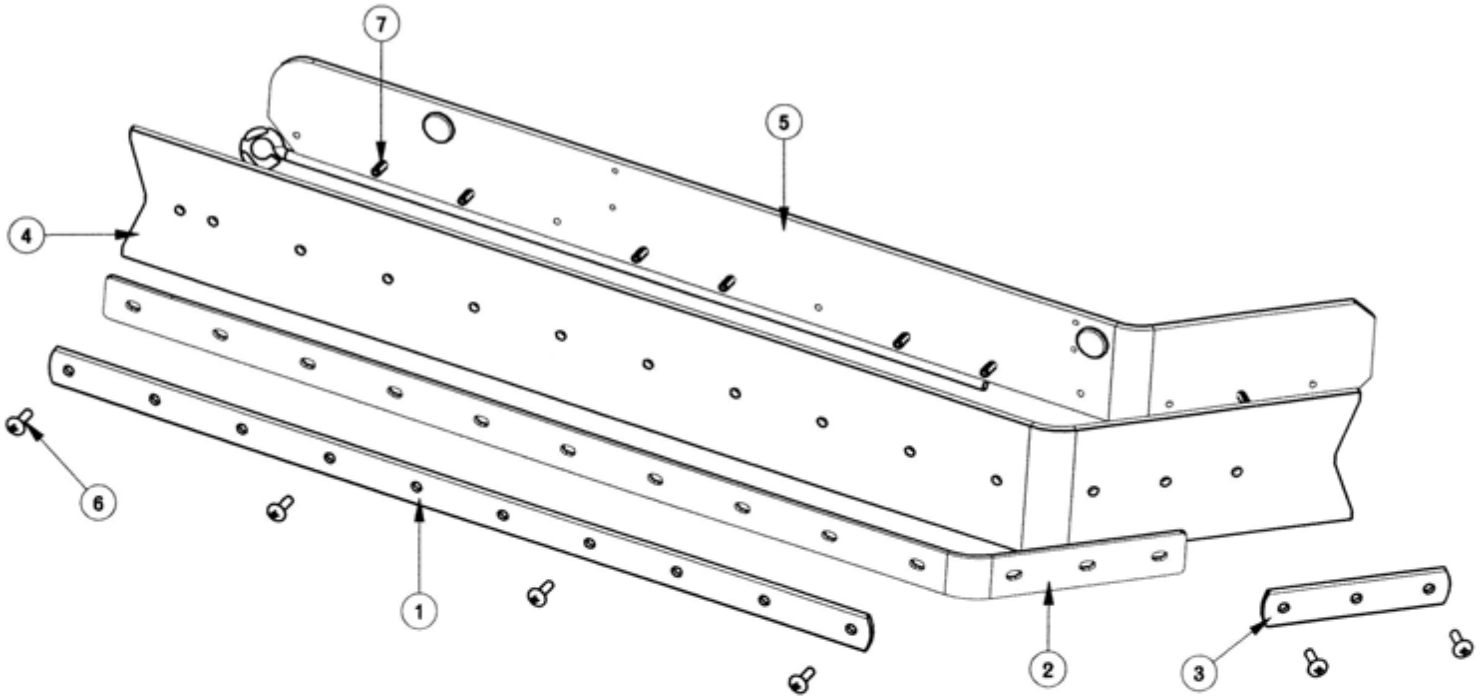

BILL OF MATERIAL - 281878			
ITEM	PART NO.	REQ'D	DESCRIPTION
1	241679	1	LONG RETAINER, SIDE SQ SCV2426
2	281855	1	BACKER BLADE, LONG SCV 2832
3	281856	1	SHORT RETAINER, SIDE SQ SCV2426
4	281859	1	SIDE SQUEEGEE BLADE LINATEX, SCV 2832
5	281880	1	DISK SQUEEGEE BRKT WMT LH,SCV2426
6	710154	6	SCR-MC TR HD 10-32 X .625 SS
7	711622	7	ROLL PIN 3/16"X 5/8"

DISK SCRUBDECK SIDE SQUEEGEE (RIGHT SIDE)

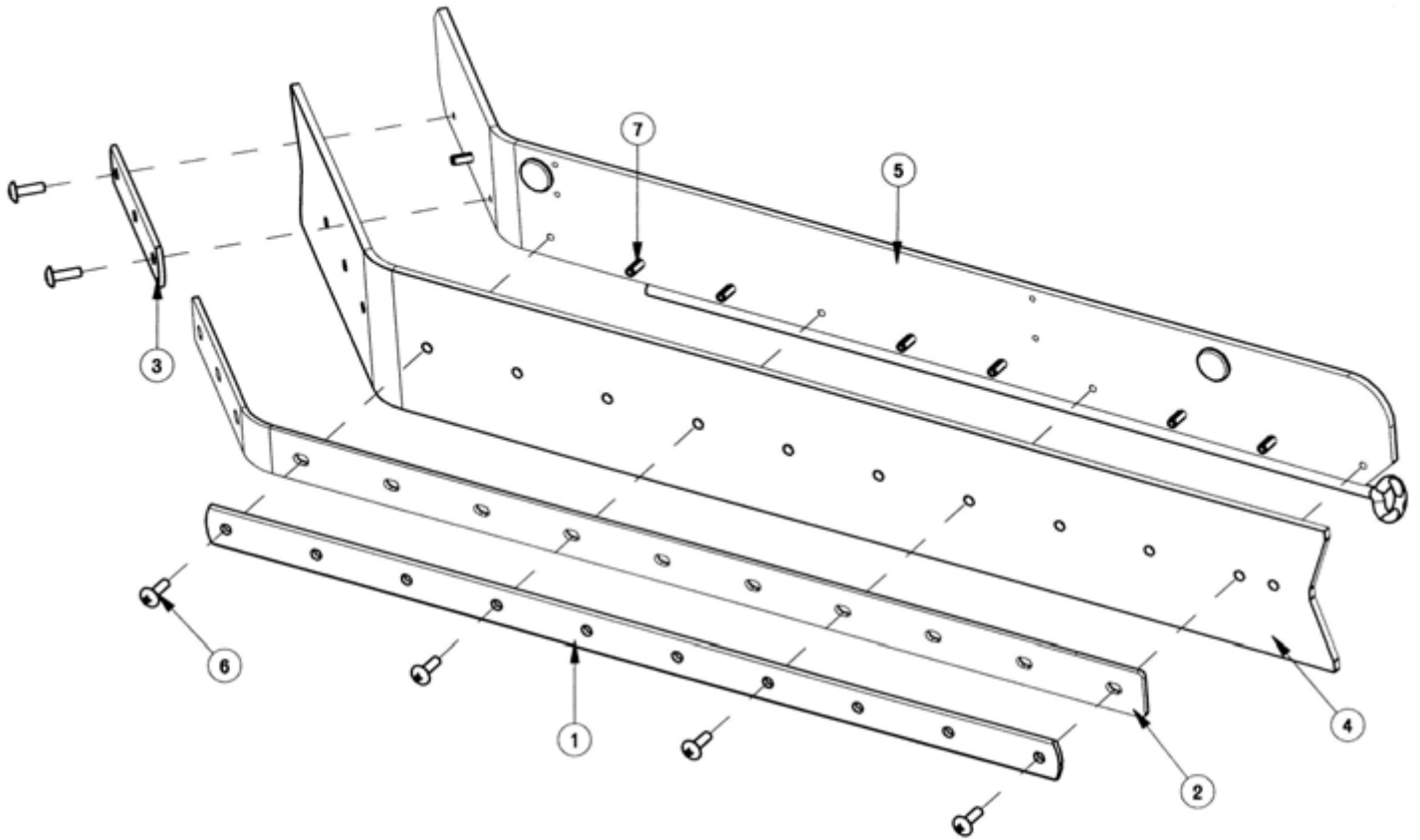

BILL OF MATERIAL - 281875			
ITEM	PART NO.	REQ'D	DESCRIPTION
1	241679	1	LONG RETAINER, SIDE SQ SCV2426
2	281855	1	BACKER BLADE, LONG SCV 2832
3	281856	1	SHORT RETAINER, SIDE SQ SCV2426
4	281859	1	SIDE SQUEEGEE BLADE LINATEX, SCV 2832
5	281877	1	SQUEEGEE BRK'T WMNT RH, SCV 2426
6	710154	6	SCR-MC TR HD 10-32 X .625 SS
7	711622	7	ROLL PIN 3/16" X 5/8"

CYLINDRICAL SCRUBDECK AND FRONT BUMPER MOUNTING - SBG

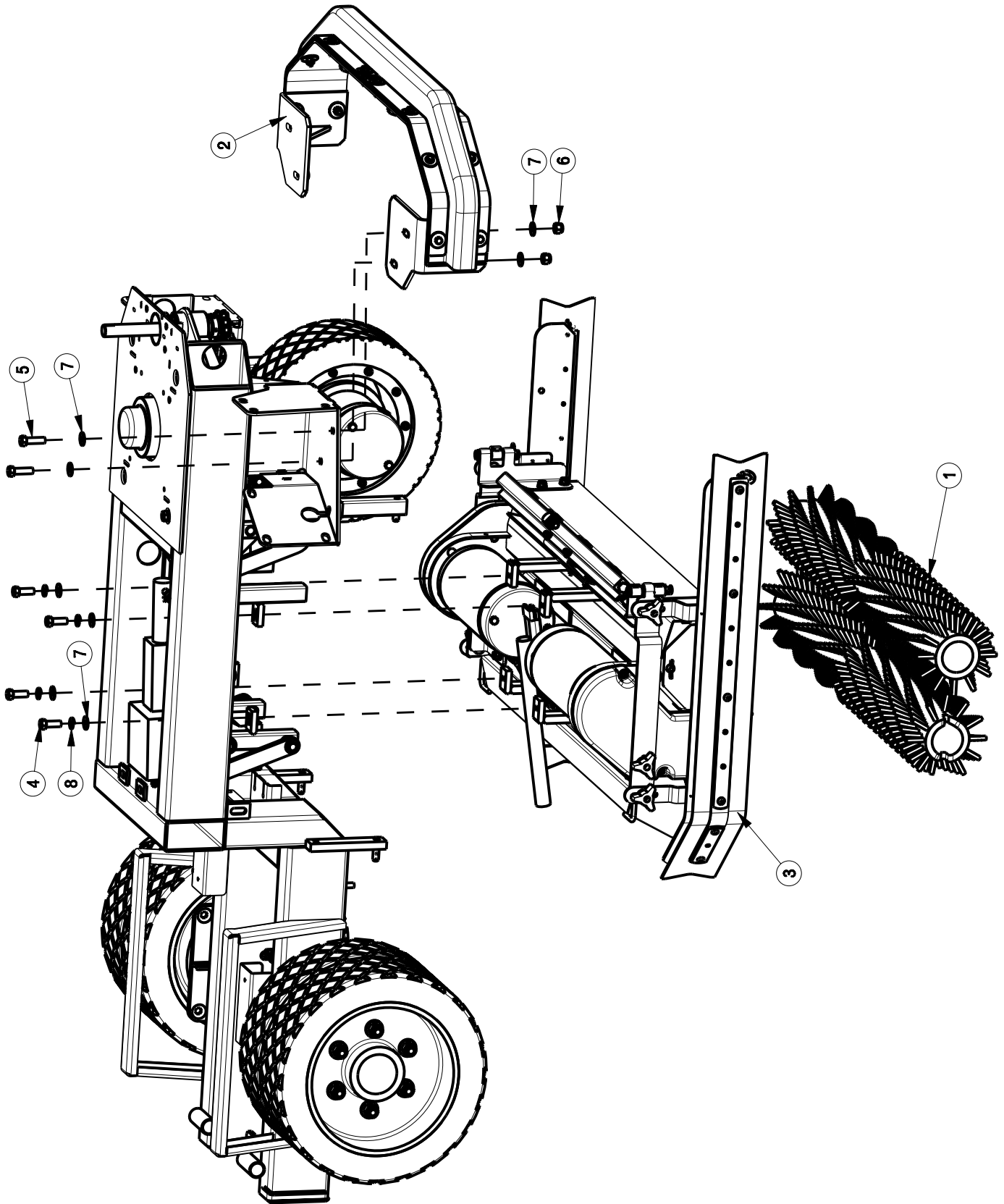

CYLINDRICAL SCRUBDECK AND FRONT BUMPER MOUNTING BOM

BILL OF MATERIAL			
ITEM	PART NO.	REQ'D	DESCRIPTION
1	281530	2	BRUSH, CYL 32" .022 NYLON
1A	281531	2	BRUSH, CYL 32" .028 NYLON
1B	281532	2	BRUSH, CYL 32" .026 PP
1C	281535	2	BRUSH, CYL 32" SCRUBGRIT II 120
1D	281536	2	BRUSH, CYL 32" NYLOGRIT 80GR
1E	281537	2	BRUSH, CYL 32" STRATAGRIT 46G
1F	281539	2	BRUSH, CYL 32" SCRUBGRIT 180GR
2	281799	1	BUMPER ASSY FRONT, SCV
3	281891	1	CYLINDRICAL SCRUBDECK ASSY, 32" NO BRUSHES
4	711242	4	BLT-HEX 3/8 -16X1.00 ZP
5	711250	4	SCR-HEX 3/8 -16X1.25 ZP
6	711380	4	NUT-NYLOC 3/8-16 NUT
7	711515	12	WSR-FLAT .406 X .812 X .0625
8	711546	4	WSR-HELICAL 3/8

DISK SCRUBDECK AND ROLLER BUMPER MOUNTING

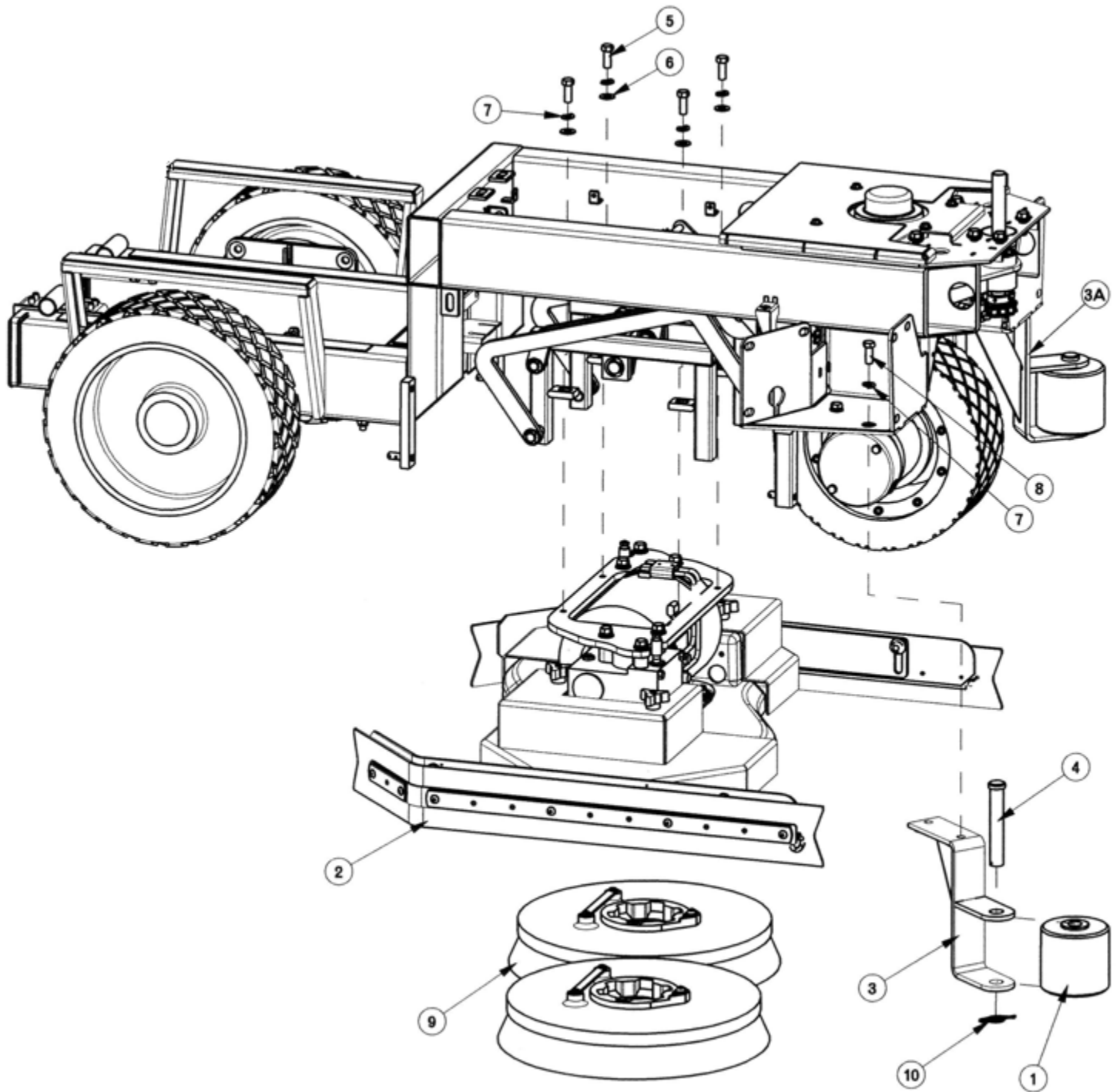

SCV28DQP & SCV32DQP BOM's

BILL OF MATERIAL - SCV28DQP			
ITEM	PART NO.	REQ'D	DESCRIPTION
1	66-436-A	2	RUBBER ROLLER
2	281870	1	DISK SCRUBDECK ASSEMBLY, 28" NO BRUSHES
3	281955	2	FRONT ROLLER MOUNT BRKT WMT
4	360017	2	3/4" X 4.50 CLEVIS PIN
5	711242	10	BLT-HEX 3/8 -16X1.00 ZP
6	711515	13	WSR-FLAT .406 X .812 X .0625
7	711546	14	WSR-HELICAL 3/8
8	713042	4	BLT-HH 3/8-16 X 1 #5
9	3313135	2	BRUSH SCRUB 14" PLASTIC NYLON
9A	3313125	2	POWER DRIVE 14" POWERGRIT 80S/S
9B	3313127	2	POWER DRIVE 14" POWERGRIT 46HDS
9C	3313131	2	BRUSH SCRUB 14" PLAS WIRE
9D	3313133	2	BRUSH SCRUB 14" PLAS BUTCHWIRE
9E	3315494	2	BRUSH 14" PWR DRIVE W/PAD HLDR
9F	3315386	2	POWER DRIVE 14" POWERGRIT 120AGS
10	3400661	2	PIN-COTTER 5/8 RUE-RING

BILL OF MATERIAL - SCV32DQP			
ITEM	PART NO.	REQ'D	DESCRIPTION
1	66-436-A	2	RUBBER ROLLER
2	281884	1	DISK SCRUBDECK ASSEMBLY, 32" NO BRUSHES
3	281976	1	FRONT ROLLER MNT BRKT WMT, RH (32" ONLY)
3A	281971	1	FRONT ROLLER MNT BRKT WMT, LH (32" ONLY)
4	360017	2	3/4" X 4.50 CLEVIS PIN
5	711242	10	BLT-HEX 3/8 -16X1.00 ZP
6	711515	13	WSR-FLAT .406 X .812 X .0625
7	711546	14	WSR-HELICAL 3/8
8	713042	4	BLT-HH 3/8-16 X 1 #5
9	3313136	2	BRUSH SCRUB 16" PLASTIC NYLON
9A	3313126	2	POWER DRIVE 16" POWERGRIT 80S/S
9B	3313128	2	POWER DRIVE 16" POWERGRIT 46HDS
9C	3313132	2	BRUSH SCRUB 16" PLAS WIRE
9D	3313134	2	BRUSH SCRUB 16" PLAS BUTCHWIRE
9E	3315495	2	BRUSH 16" PWR DRIVE W/PAD HLDR
9F	3315385	2	POWER DRIVE 16" POWERGRIT 120AGS
10	3400661	2	PIN-COTTER 5/8 RUE-RING

PLUMBING DIAGRAM

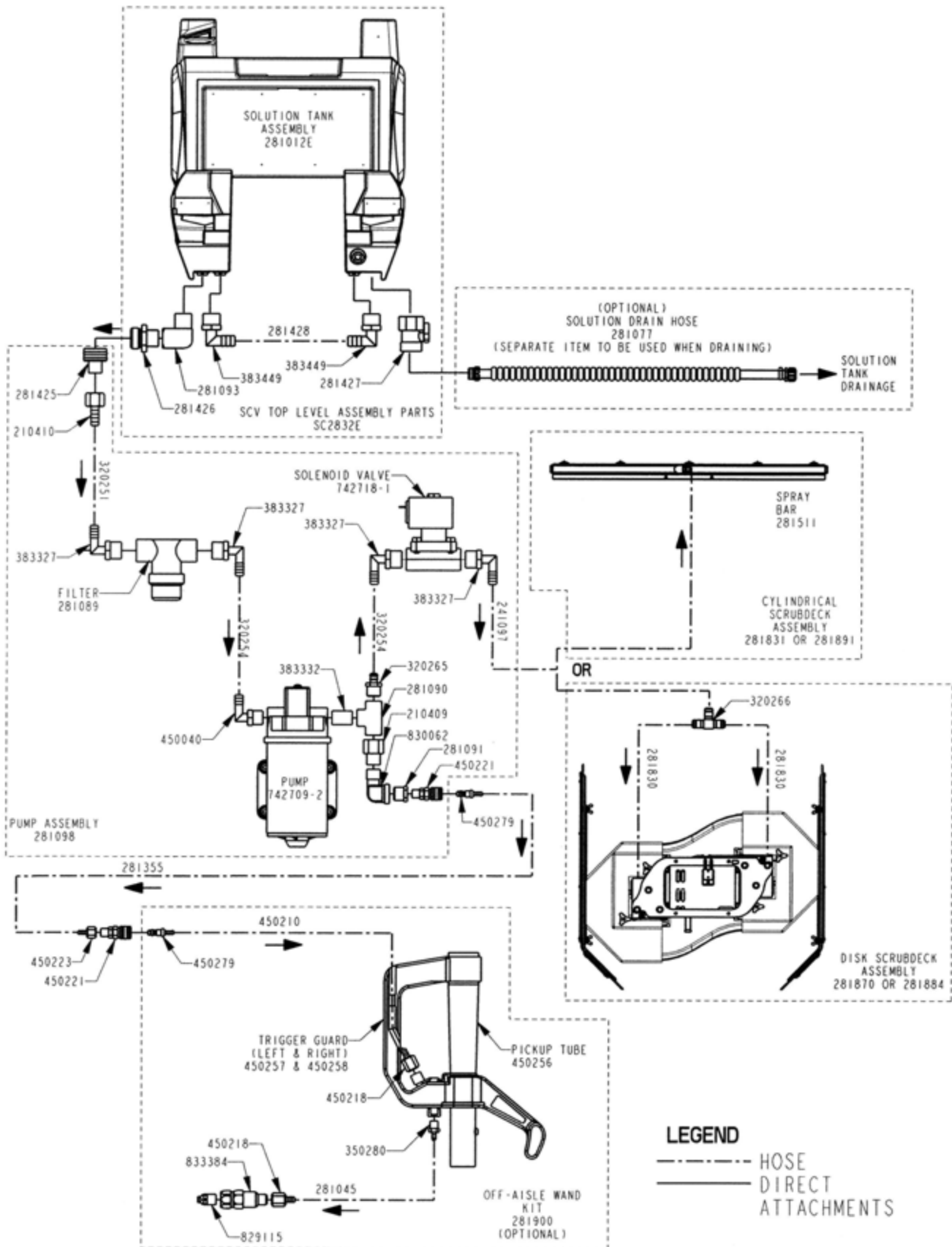

715908: DIAGNOSTIC CODE DECAL

- DIAGNOSTIC CODES : BATTERY GAUGE (747011)
- 10 BARS FLASHING : HIGH BATTERY VOLTAGE
- 9 BARS FLASHING : SOLENOID BRAKE FAULT
- 8 BARS FLASHING : CONTROL SYSTEM FAULT
- 7 BARS FLASHING : THROTTLE FAULT
- 6 BARS FLASHING : OFF AISLE WAND SWITCH ON
- 5 BARS FLASHING : VACUUM MOTOR FAULT
- 4 BARS FLASHING : FREEWHEEL ACTIVE
- 3 BARS FLASHING : BRUSH MOTOR FAULT
- 2 BARS FLASHING : TRACTION MOTOR FAULT
- 1 BAR FLASHING : LOW BATTERY VOLTAGE
- 10 BARS RIPPLING UP AND DOWN: THROTTLE IS DISPLACED

ON START UP

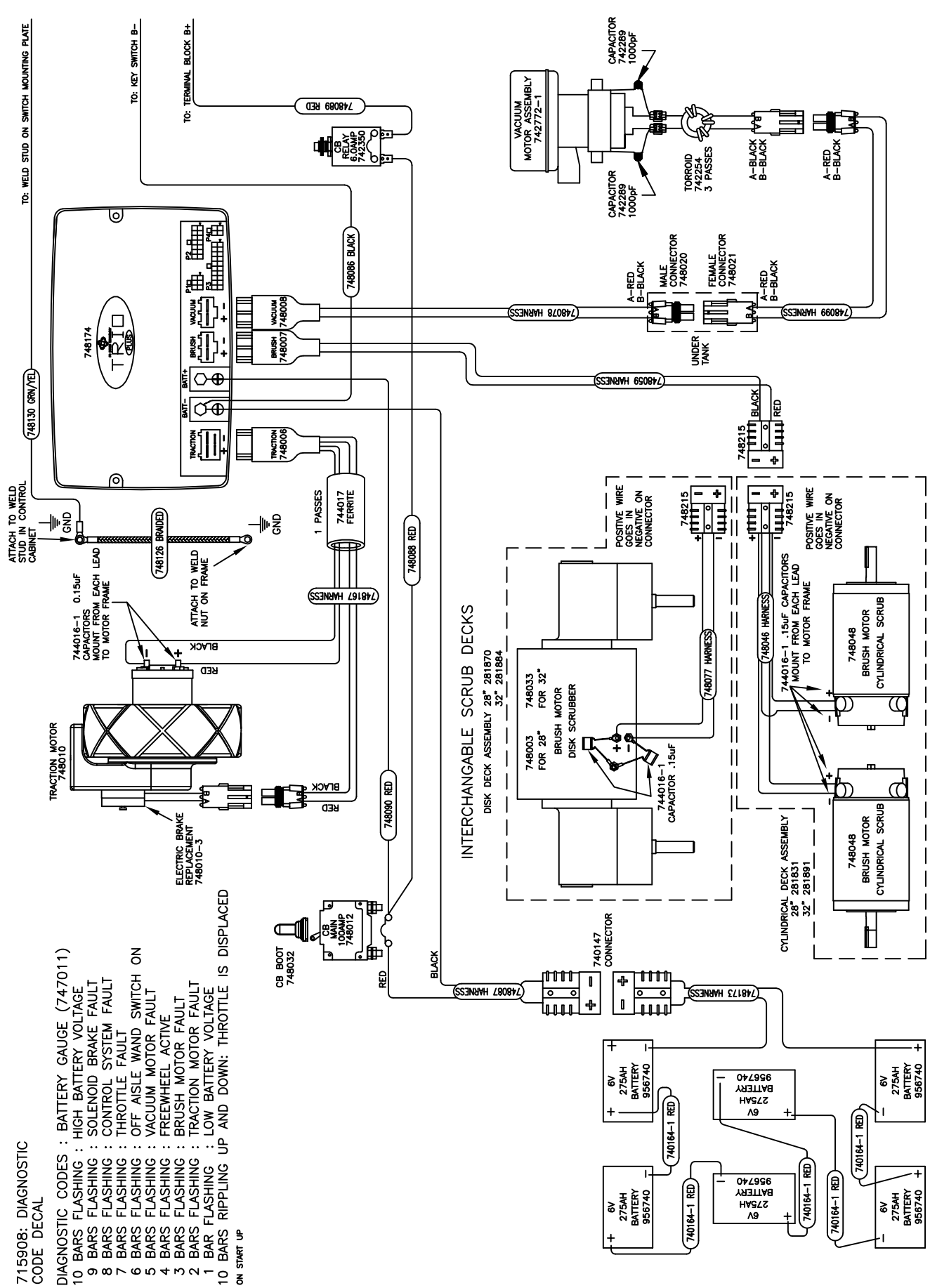

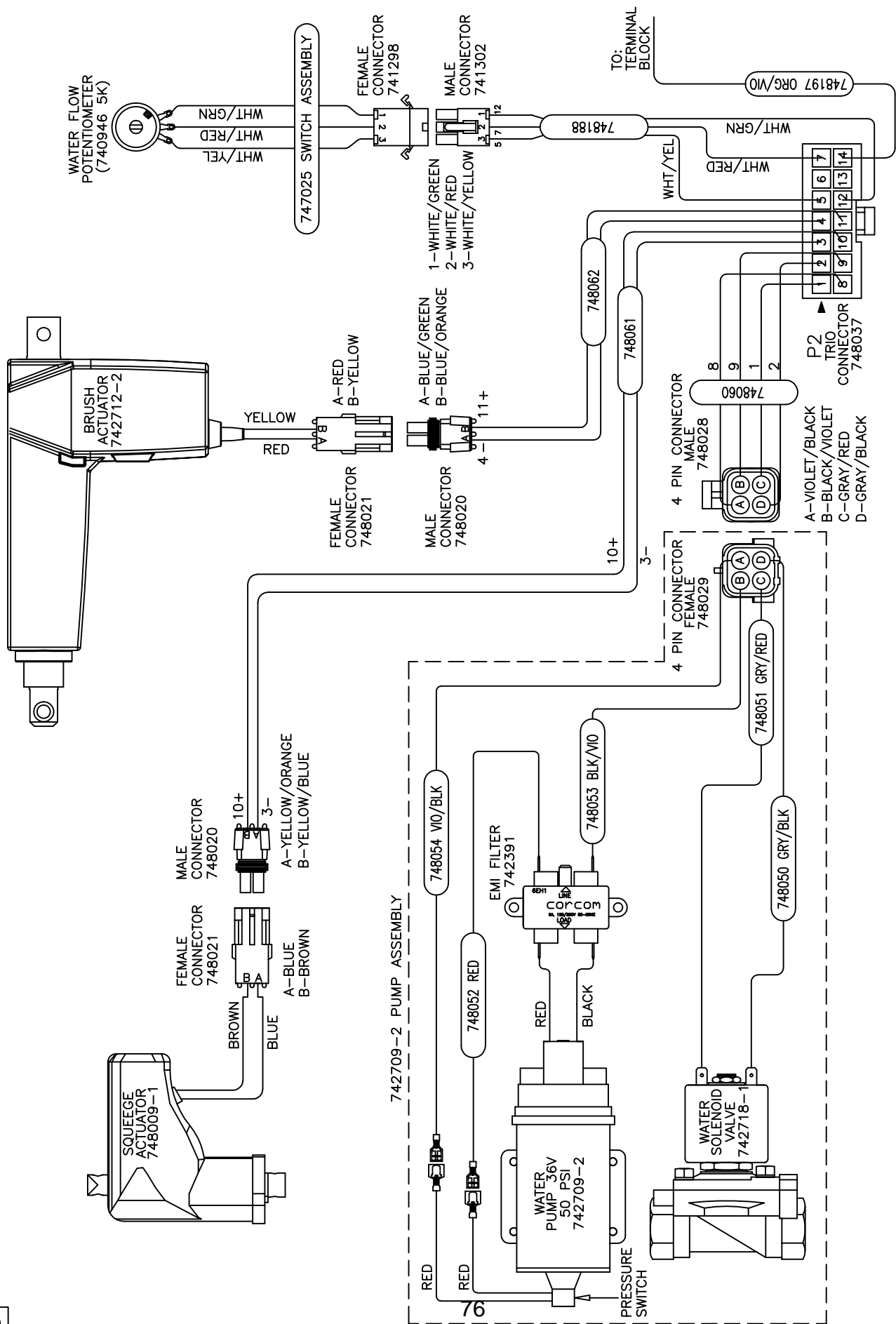

KEY SWITCH

PIN #	HARNES COLOR	FUNCTION
1	RED/VIOLET	POSITIVE TO LEDS
2	RED/VIOLET	E-STOP-TRIO KSI P3:18
3	RED/WHITE	+V FROM TRIO P3:8
4	EMPTY	-

MODE SELECTOR SWITCH

SWT #	PIN #	COLOR	FUNCTION
1	1	YELLOW/BLACK	HEAVY SCRUB
2	2	YELLOW/RED	LIGHT SCRUB
3	3	YELLOW/GRAY	DOUBLE SCRUB
4	4	YELLOW/WHITE	VACUUM ONLY
5	5	YELLOW	TRANSPORT
C	6	RED/BLACK	SWITCH REF 5V

BATTERY GAUGE

PIN #	COLOR	FUNCTION
1	RED/VIOLET	SWITCHED 36VDC:P3-18
2	RED/YELLOW	SIGNAL: P3-6
3	BLACK/RED	SIGNAL REF 0V
4	GREEN/YELLOW	ESD DISCHARGE

REVERSE SWITCH

PIN #	COLOR	FUNCTION
1	YELLOW/VIOLET	REVERSE
2	RED/BLACK	HIGH SWITCH REF 5VDC
3	EMPTY	-
4	RED/VIOLET	REVERSE LED
5	RED/VIOLET	KEY SWITCH ON
6	RED/VIOLET	FORWARD LED

SIDE TO SIDE SWITCH

PIN #	COLOR	FUNCTION
1	BROWN/GRAY	SIDE ACTUATOR
2	RED	BATTERY 36VDC
3	BROWN/YELLOW	SIDE ACTUATOR
4	BROWN/YELLOW	SIDE ACTUATOR
5	BLACK	BATTERY 0VDC
6	BROWN/GRAY	SIDE ACTUATOR

P2: TRIO CONNECTOR

PIN #	COLOR	FUNCTION
1	GRAY/RED	WATER SOLENOID VALVE
2	GRAY/BLACK	WATER SOLENOID VALVE
3	YELLOW/ORANGE	SQUEEGE ACTUATOR
4	BLUE/GREEN	BRUSH ACTUATOR
5	WHITE/YELLOW	WATER FLOW POTENTIOMETER (SLOW)
6	-	-
7	WHITE/RED	WATER FLOW POTENTIOMETER (WIPER)
8	VIOLET/BLACK	WATER PUMP
9	BLACK/VIOLET	WATER PUMP
10	YELLOW/BLUE	SQUEEGE ACTUATOR
11	BLUE/ORANGE	BRUSH ACTUATOR
12	WHITE/GREEN	WATER FLOW POTENTIOMETER (FAST)
13	-	-
14	ORANGE/VIOLET	BRUSH DECK PRESSURE SETTING

P3: TRIO CONNECTOR

PIN #	COLOR	FUNCTION
1	YELLOW/RED	5 MODE SWITCH: LIGHT SCRUB
2	YELLOW/BLACK	5 MODE SWITCH: HEAVY SCRUB
3	YELLOW	5 MODE SWITCH: TRANSPORT
4	-	-
5	BLUE/WHITE	DECK RAISE/LOWER SWITCH
6	RED/YELLOW	BATTERY GAUGE SIGNAL
7	GRAY/YELLOW	HOUR METER
8	RED/WHITE	ON/OFF REF (B+)
9	BLACK/ORANGE	SPEED POTENTIOMETER (SLOW)
10	BLACK/PINK	SPEED POT./SEAT SAFETY SWITCH
11	YELLOW/WHITE	5 MODE SWITCH: VACUUM ONLY
12	YELLOW/GRAY	5 MODE SWITCH: DOUBLE SCRUB
13	YELLOW/VIOLET	REVERSE SWITCH
14	BROWN/GREEN	SOLUTION TANK EMPTY FLOAT SWITCH
15	WHITE/BLUE	OFF AISLE WAND
16	RED/BLACK	HIGH SWITCH REF 5VDC
17	BROWN/BLACK	BACK UP ALARM
18	RED/VIOLET	ON/OFF INPUT-KEY SWITCH
19	BLACK/RED	LOW SWITCH REF 0VDC
20	BLACK/WHITE	SPEED POTENTIOMETER (FAST)

MISCELLANEOUS

COLOR	FUNCTION
RED	BATTERY 36VDC
BLACK	BATTERY 0VDC
RED/BLACK	HIGH SWITCH REF 5VDC
BLACK/RED	LOW SWITCH REF 0V
BLUE/YELLOW	HORN



Minuteman International Made Simple Commercial Limited Warranty

Minuteman International, Inc. warrants to the original purchaser/user that the product is free from defects in workmanship and materials under normal use. Minuteman will, at its option, repair or replace without charge, parts that fail under normal use and service when operated and maintained in accordance with the applicable operation and instruction manuals. All warranty claims must be submitted through and approved by factory authorized repair stations.

This warranty does not apply to normal wear, or to items whose life is dependent on their use and care, such as belts, cords, switches, hoses, rubber parts, electrical motor components or adjustments. Parts not manufactured by Minuteman are covered by and subject to the warranties and/or guarantees of their manufacturers. Please contact Minuteman for procedures in warranty claims against these manufacturers.

Special warning to purchaser -- Use of replacement filters and/or prefilters not manufactured by Minuteman or its designated licensees, will void all warranties expressed or implied. A potential health hazard exists without original equipment replacement.

All warranted items become the sole property of Minuteman or its original manufacturer, whichever the case may be.

Minuteman disclaims any implied warranty, including the warranty of merchantability and the warranty of fitness for a particular purpose. Minuteman assumes no responsibility for any special, incidental or consequential damages.

This limited warranty is applicable only in the U.S.A. and Canada, and is extended only to the original user/purchaser of this product. Customers outside the U.S.A. and Canada should contact their local distributor for export warranty policies. Minuteman is not responsible for costs or repairs performed by persons other than those specifically authorized by Minuteman. This warranty does not apply to damage from transportation, alterations by unauthorized persons, misuse or abuse of the equipment, use of non-compatible chemicals, or damage to property, or loss of income due to malfunctions of the product.

If a difficulty develops with this machine, you should contact the dealer from whom it was purchased.

This warranty gives you specific legal rights, and you may have other rights which vary from state to state. Some states do not allow the exclusion or limitation of special, incidental or consequential damages, or limitations on how long an implied warranty lasts, so the above exclusions and limitations may not apply to you.

Cord Electric Group..... Three years parts, two years labor, ninety days travel (Not to exceed two hours)

Exceptions..... Port-A-Scrub, one year parts, six months labor

MPV 13, one year parts

MPV 14 and 18, two years parts, one year labor

RapidAir blower, one year parts, one year labor

Explosion-Proof Vacuum, one year parts, one year labor

Pneumatic Vacuums, three years parts, one year labor

Battery Operated Group..... Three years parts, two years labor, ninety days travel

(Not to exceed two hours)

Exceptions..... Sweepers, one year parts, one year labor, ninety days travel

(Not to exceed two hours)

Internal Combustion Group.... One year parts, one year labor, ninety day travel

(Not to exceed two hours)

Replacement Parts.....Ninety days

Batteries.....0-3 months replacement, 4-12 months pro-rate

Polypropylene Plastic Tanks... Ten years, no additional labor

A Member of the Hako Group of Companies

111 South Rohlwing Road · Addison, Illinois 60101 USA

Phone 630- 627-6900 · Fax 630- 627-1130

E-Mail, www.minutemanintl.com

987616

Rev * 12/06

Printed in USA