



Electronic Service Manuals

This electronic document is provided as a service to our customers. We do not create the contents of the information contained in this document. Should you have detailed questions pertaining to the information contained in this document, you may contact Michco, or the manufacturer which provided the original information in this electronic deliverable. Michco's only part in this electronic deliverable was the electronic assembly process. By providing this manual online we are not guaranteeing parts availability.

You may contact Michco through the following methods:

Phone (517) 484-9312

2011 N. High St. -- Lansing, Michigan -- 48906

Fax: (517) 484-9836

Email: CustomerService@Michco.com

Website: www.Michco.Com

Order Parts online at:

www.Michco.Com

Directly to Parts & Service:

By Email: **CustomerService@Michco.com**

By Fax: (517) 484-9836

By Voice: (517) 484-9312

Serving the Cleaning Industry Since 1922

Notice: All copyrighted material remains property of original owners, all trademarks are property of respective owners. Manuals are subject to Manufacturer's reproduction limitations. Originals or reproductions were provided by manufacturers through a request. We make no warranty as to the correctness of information provided in this document and you assume all risk. By placing these manuals on line we are not declaring our corporation to be an manufacturer authorized dealer or provider, please check our web site for authorized manufacturers we represent.



**Parts and Instruction Manual
R100C Rush Carpet Extractor**

Model R100C

Model	Rush 100 Cold
Solution Tank	12 gallon
Recovery Tank	11 gallon
Vacuum Motors	Dual 2-stage
Solution Pressure	100 psi
Water Lift	150"
Tank Construction	Polyethylene
Baseplate	¼" aluminum
Rear Wheels	10" non-marking
Casters	4" locking
Power Cord	50 ft. detachable
Dimensions	35"H x 31"L x 18"W
Weight	78 lbs.
Shipping Weight	94 lbs.
Shipping Dimensions	36.5"H x 31.5"L x 19"W
Electrical Draw	13.5 amps
Heater	No Heat
Vacuum/Solution Hose	15'
Carpet Wand	Single Jet – Stainless Steel

Table of Contents

TECHNICAL SPECIFICATIONS	2
INSPECTION.....	4
SAFETY INSTRUCTIONS.....	5
GROUNDING	7
MAINTENANCE	8
MACHINE OVERVIEW.....	10
CLEANING CARPET	11
CLEANING UPHOLSTERY.....	12
WIRING	13
UPPER ASSEMBLY	14
UPPER ASSEMBLY BOM	15
LOWER ASSEMBLY	16
LOWER ASSEMBLY BOM	17
WARRANTY	20

UNPACKING YOUR NEW R100C: When your package is delivered, check the carton carefully for signs of rough handling. If your R100C is damaged, notify the carrier immediately and request an inspection. Be sure to keep the carton, packing inserts, packing lists and carrier's receipt until the inspector has verified your claim.

MINUTEMAN's liability ceases when the carrier picks up the shipment. However, our customer service staff will be happy to furnish any information needed in connection with the claim and will attempt to expedite a resolution.



PLEASE READ BEFORE OPERATING YOUR NEW R100C:

Read the manual carefully and completely before attempting to operate the unit. This manual has important information for the use and safe operation of the machine. Keep this manual handy at all times.

This equipment has been engineered and manufactured to provide excellent performance and service. To ensure that your equipment will continue to perform as intended:

- Maintain equipment regularly- following the suggested maintenance schedule provided.
- Use only original MINUTEMAN parts when servicing.
- Operate equipment with care.

If additional information is needed, please contact:
MINUTEMAN INTERNATIONAL 630- 627-6900

All information and specifications printed in the manual are current at the time of printing; however because of MINUTEMAN's policy of continual product development, we reserve the right to make changes at any time without notice.

FAILURE TO COMPLY WITH THE FOLLOWING WARNINGS AND INSTRUCTIONS WILL VOID THE WARRANTY.

WARNING!

- The machine was designed for use on carpet cleaning applications as per instructions and recommendations written in this manual. Any deviation from its proper use or purpose and the consequential damage that may occur is the sole responsibility of the end user.
- Disconnect the power cord from the outlet before servicing. Do not leave machine connected to an electrical outlet when unattended.
- Do not immerse or use this machine in standing water. Such use may cause electric shock.
- When using an extension cord, use only a 3-prong conductor grounding cord-12 gauge wire or heavier.
- To avoid electric shock, do not expose the unit to rain or snow. Store it indoors in a heated location only.
- Do not use the machine for dry vacuuming.
- Use defoamer at all times to prevent damage to the vacuum motor.
- Do not use water in excess of 130°F (54°C) in the solution tank
- To prevent seal damage and chemical build-up to the pump system, run clean water through the solution lines after each day's use.
- Use only commercially available carpet cleaning solutions and defoamer intended for use with machines of this type. Do not use dyes, bleaches, ammonia, or other additives.
- The use of powdered cleaning solution, if not diluted properly, may result in damage to the pump. Powdered chemical is not recommended. If powdered chemicals are used, premix in a separate container before placing in the solution tank.
- Always read and understand your chemical's MSDS (Material Safety Data Sheet) before use.
- This equipment is not designed to handle or use combustible/volatile substances such as gasoline or kerosene, in, on, or near the machine. The use of such materials will cause extreme hazardous condition.
- Do not expose machine to freezing temperatures.

- All repairs must be done by an authorized MINUTEMAN repair station.
- Do not use replacement parts other than original MINUTEMAN parts.
- Do not allow your spray stream to remain in one fixed location as surface damage may occur.
- Check that all spray nozzles are securely fastened. Loose nozzles could be ejected from equipment at high speeds.
- This is not a toy. Keep away from children.
- Do not pull by the power or use power cord as a handle. Always unplug by grabbing the plug and pulling, do not unplug by pulling the power cord.
- Inspect cord for damage. Do not use damaged cords. Connect only to properly grounded outlets.
- Keep hair, fingers, loose clothing, and body parts away from moving parts and openings.
- Turn off all controls before disconnecting machine
- Use caution with ejected liquid or chemicals. High pressures and temperatures could be hazardous to nearby people or surroundings.



ELECTRICAL - 115 Volt

Model: R100C

This machine is designed to operate on a standard 15 amp, 120 volt, 60 Hz, AC circuit. Voltages below 105 volt AC or above 125 volts AC could cause serious damage to the motor.

GROUNDING INSTRUCTIONS:

This piece of equipment must be grounded. Should an electrical malfunction occur, grounding provides a path of least resistance for electrical current- reducing the risk of electric shock. This piece of equipment is furnished with a cord that has a grounding conductor and grounding plug. The grounded plug must only be plugged into an appropriate outlet that is properly installed and grounded in accordance with all local codes and ordinances.

WARNING:

Connecting the equipment to an improperly grounded outlet can result in an increased risk of electric shock. A qualified electrician should be consulted if you are unsure that the outlet is properly grounded. Do not modify the plug provided with the equipment. If it will not fit the outlet, have a proper outlet installed by a qualified electrician.

This appliance is designed for use on a 120-volt circuit. The grounding plug provided looks like the plug illustrated in Figure 1. Replace the power cord if the grounding pin is damaged or broken.

Extension cords connected to this machine should be 12 gauge, three-wire cords with three-prong plugs and outlets. DO NOT use extension cords more than 25 feet (7.6 m) long

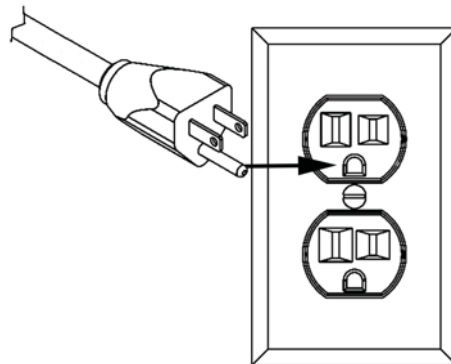

Figure 1

MAINTENANCE:

This R100C has been engineered and built to require minimum maintenance. But like any machine, it does require some care to keep it in optimum working condition. Careful attention to these maintenance instructions will give you maximum operating performance and life expectancy of the machine.

CAUTION: Disconnect the power cord from the outlet before doing any clean up or maintenance on the machine

- Keep the machine clean. Do not allow dust to accumulate on external surfaces or near any moving parts.
- After every job, wipe down the surface of the machine with a clean damp cloth.
- Inspect cord for damage. Do not use machine with a damaged cord.

PERIODIC MAINTENANCE

- Use only chemicals safe for extractors
- Adhere to the appropriate mix ratios for all chemicals
- For optimal performance, it is suggested that the operator flush the system after every job or at the end of the day.
- Pump seals and valves may need to be replaced at the 1000 hour mark if a loss in pressure is noted

Daily:

1. Always keep the machine clean inside and out.
2. Pour 2 gallons of clean hot water in the solution tank. Turn the pump on and flush the entire system through the wand nozzles for about a minute to prevent alkaline build-up.
3. Remove dirt and lint build-up inside the filter screen in the recovery tank. Lint should be cleaned off so that air flow is not impeded.
4. Check the solution tank strainer in the solution tank. If lint has accumulated in the screen, remove and rinse it in clear running water.

Weekly:

1. Check and clean solution filter
2. Check for obstructions in vacuum pathway

Quarterly:

1. Check pump, plumbing and fittings for leaks
2. Check power cords and hoses for tears

CORD STORAGE:

While not in use, storage can be accomplished by winding cord around handle assy. Cord should be completely unwound during operation.

CORD SAFETY

- Do not leave appliance when plugged in. Unplug from outlet when not in use and before servicing
- Do not use with damaged cord or plug. If appliance is not working as it should, has been dropped, damaged, left outdoors, or dropped into water, return to service center for inspection and repair.
- Do not pull or carry by cord, use cord as handle, close a door on cord, or pull cord around sharp edges or corners. Do not run this R100C over cord. Keep cord away from heated surfaces.
- Do not unplug by pulling cord. To unplug, grasp the plug, not the cord.
- Do not handle plug or appliance with wet hands.
- This equipment should be stored indoors and not exposed to rain.

MACHINE OVERVIEW

1. Handle- Used to maneuver and position the R100C.
2. Contains switch box (For switchbox, see #10)
3. Recovery tank and lid- Tank collects recovered waste water. Lid allows access to recovery tank and creates a seal to ensure suction.
4. Solution tank and lid- Tank used to store clean water or solution for your job. Lid allows access to the solution tank and prevents external contamination of solution tank.
5. Non-marking front 4" locking casters and rear 10" wheels
6. Recovery/vacuum hose inlet barb- connect your recovery vacuum hose to this barb
7. Solution line Q.D.- Pressurized connection for solution line
8. Twist lock pigtail- connects to 50ft power cord
9. Cool air intake for vacuum
10. Recovery tank dump valve- Pull up to open
11. Switch box- Two switches marked "VACUUM" and one switch marked "PUMP". Switches light up when powered on.

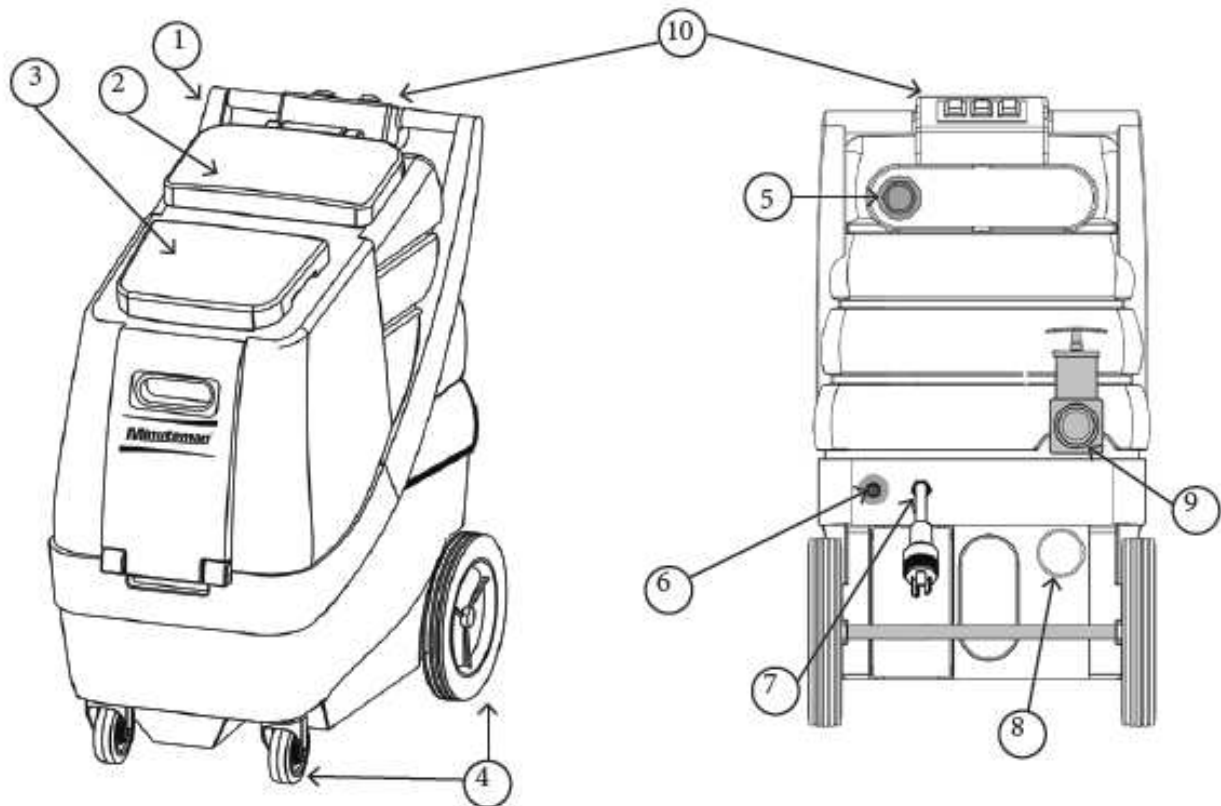

CLEANING CARPET

- Using a dedicated dry vacuum, pre-vacuum the space to be cleaned to remove as much dirt as possible. Do not use the extractor to dry vacuum as it does not have a dry filter.
- Pre-spray the carpet
- Pour clean water or solution into the solution tank. Do not use water over 130 degrees F.
- Slide vacuum hose on to the black hose adapter (located at the back of machine) and the wand or upholstery tool. (see #5 on page 10)
- Connect the female on your solution hose to the male Q.D. on the machine (#6 on page 10).
- Connect the male end of the solution hose to the wand.
- Make sure the drain valve (#9 on page 10) is closed by pushing the T-handle all the way in.
- Always use de-foamer. Previously shampooed carpets usually have a heavy build-up of old shampoo residue which can cause the vacuum system to ingest foam and result in damage to the vacuum motor.
- Turn on the vacuum and solution switches. Slowly pull the tool towards you with the solution valve trigger engaged. Then make a pass forward and backward with only the vacuum motor on (no spray) over the cleaned area to remove as much dirt and solution as possible. Do not over wet carpet! Make overlapping passes to prevent streaking.
- If the carpet is heavily soiled, squeeze solution valve lever on the forward pass as well as backwards, allowing cleaning solution a few seconds longer to work prior to vacuuming. Another method is to raise the wand 8" above the carpet and pre-spray lightly prior to cleaning passes. On extremely soiled carpets, we recommend using a pre-spray solution.
- When you are close to running out of solution, turn off the pump. Attach the drain elbow on the drain valve. Place a pail under the downspout and pull up the drain valve T-handle. Dirty solution will pour out until the tank is empty. Close the drain valve. Use a clean bucket when you refill the solution tank.
- When the job is completed, turn the switches off, disconnect the vacuum and solution hoses from the carpet tool and the machine. Drain the recovery tank through the drain valve as before.

CLEANING UPHOLSTERY:

Cleaning upholstery with success requires a good knowledge of the type of fabric to be worked on. Look for the cleaning instruction label sewn on the underside of the furniture for the recommended method of cleaning the fabric. If it calls for dry cleaning, do not attempt to clean with the wet extraction method. Otherwise, damage to the fabric could occur. Extraction works perfectly on most synthetic fabrics including synthetic velvets.

Before proceeding, test the fabric for colorfastness. Apply a small amount of ready-to-use cleaning solution on the fabric in an inconspicuous spot. Wait for 2 to 3 minutes and rub the area with a white terry cloth towel. If no color comes off the towel, the fabric should be safe to clean. If a little color comes off, there is some risk of colors running when you clean. It may be possible to stabilize colors by cleaning with an acidic rinse.

- Prepare the machine in the same manner as for carpet cleaning (see CLEANING CARPET), except attach the upholstery tool to the vacuum and the solution hose.
- Pour hot water into the solution tank. Add recommended amount of cleaning concentrate into the solution tank. Do not use water over 130 degrees F.
- Turn on the vacuum and pump switches.
- Clean with the upholstery tool using as little solution as possible. Make overlapping passes to prevent streaking. Go over the area you just cleaned without depressing the lever (vacuum only) and gauge the amount of moisture extracted through the view window for dryness. On heavily soiled areas like arm rests, pre-treat with a recommended pre-spray and / or hold the upholstery tool a few inches above the fabric and press lever to spray on the solution before making a pass.

R100C WIRING

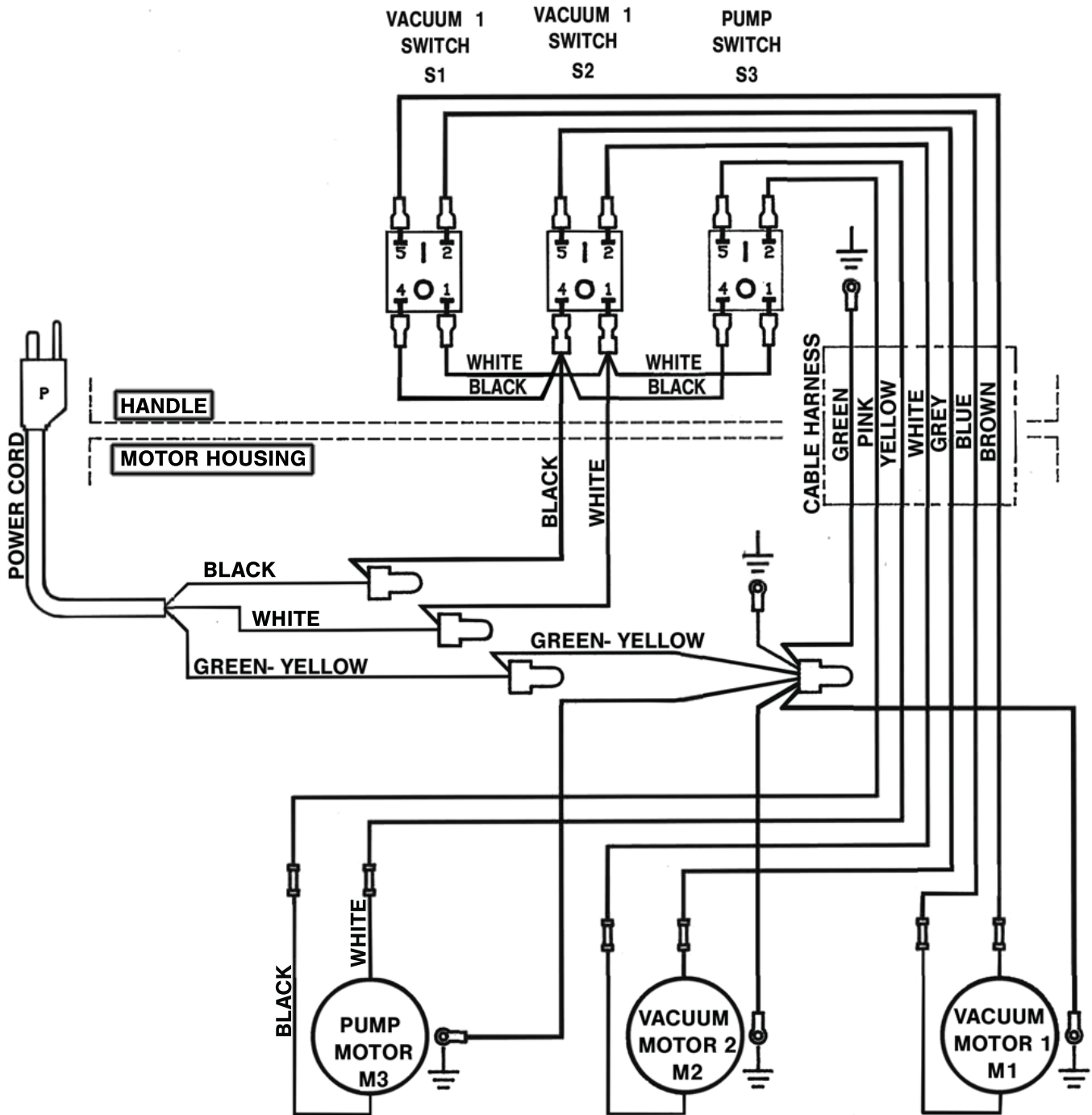

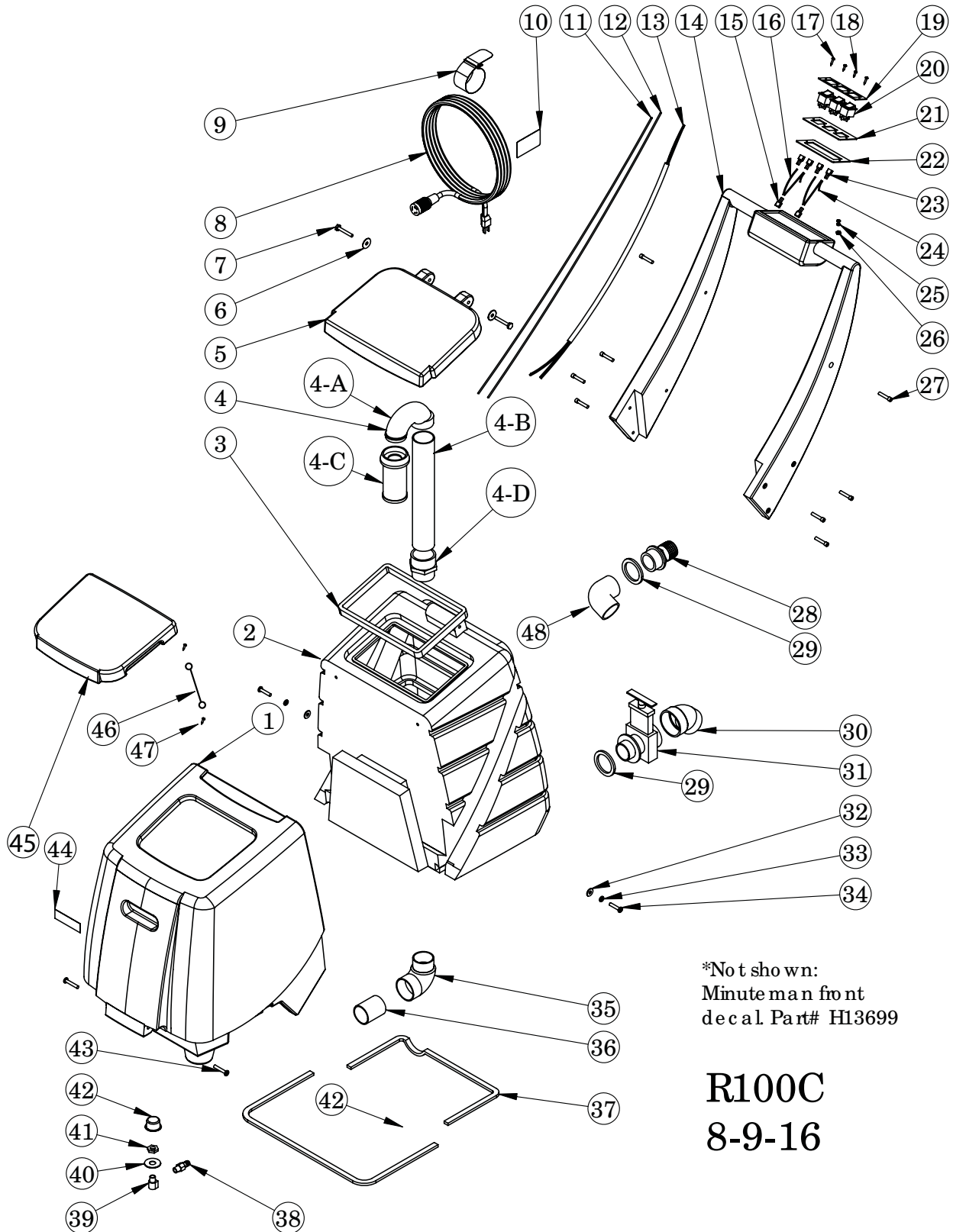

*Not shown:
Minute man front
decal Part# H13699

R100C
8-9-16

UPPER ASSEMBLY BOM

BILL OF MATERIAL							
ITEM	PART NO.	QTY	DESCRIPTION	ITEM	PART NO.	QTY	DESCRIPTION
1	F11787-MM	1	SOLUTION TANK	23	B00177-1	4	TERMINAL LUG, FEMALE, QD, 0.25 X 0.032
2	F11788-MM	1	RECOVERY TANK	24	B00185-30	1	WIRE, 14 GA WHITE, UL1015, 10 IN
3	E11124	1	GASKET, RECOVERY TANK	25	C02315	2	LOCKWASHER, #10 INT. STR, SS
4	12904A	1	STAND PIPE ASSEMBLY	26	C00264	1	NUT, 10-32
4-A	K11965	1	ELBOW, 180 DEG. FLOAT BALL	27	C11141	8	SCREW, ALLEN HEAD, 10-24 X 1.25 IN
4-B	K00672	1	PVC PIPE, 1.5 X 12 IN, SCH 40 WHT	28	K00665-1	1	HOSE ADAPTER, 1.5IN, BLACK
4-C	10989-2A	1	FLOAT BALL SCREEN	29	E11128	2	GASKET, DRAIN VALVE
4-D	K00741	1	ADAPTER	30	K00710	1	ELBOW, DRAIN VALVE, BLACK
5	F11785-MM	1	LID, RECOVERY TANK	31	K00711	1	DRAIN VALVE, BLACK
6	C12039	2	WASHER, 1/4 X 1, SS	32	C00233	2	WASHER, FLAT, .25 IN
7	C02322	2	1/4 X 20 BOLT	33	C00254	2	LOCK WASHER, 1/4IN SPLIT
8	B11769	1	EXTENSION CORD, 12-3 SJTW	34	C02294	2	SCREW, 1/4 - 20 X 1.25
9	B12915	1	VELCRO STRAP	35	K11185	1	ELBOW, 90, 1.5 IN, MT-MS, PVC
10	H02548-2	1	LABEL, IMPORTANT, CORD	36	K00672-1	1	PVC PIPE, 1.5 X 2.25 IN,
11	B00185-30	1	WIRES, 73 IN	37	E11129	1	GASKET, BASE
12	B00185-40	1	WIRES, 73 IN	38	A00060	1	3/8 BARB X 1/4MP, BRASS
13	B010314	1	WIRE HARNESS	39	A00052	1	.25 X .375 M-F 90 DEG
14	F11786-MM	1	HANDLE	40	C11244	1	WASHER, .56 X 1.5 X 0.05
15	B00177	2	TERMINAL LUG, FEMALE, QD, 0.25 X .032, 16-14 AWG, FULLY	41	A00124	1	HEX NUT, .25 NPT BRASS
16	B00185-40	1	WIRE, 14 GA BLACK, UL1015, 10 IN	42	D00373	1	INLET FILTER, .25 NPT
17	C00295-1	2	#10 X .75IN PAN, BLACK SMS, PHILLIPS	43	C11143	2	SCREW, 1/4 - 20 X 1.5 IN, SS
18	C00293	2	#8 X .5IN PAN, BLACK SMS, PHILLIPS	44	S11179	1	NON-SKID TAPE, 1 IN. ROLL
19	D11168	1	COVER, SWITCHPLATE	45	F11791-MM	1	LID, SOLUTION TANK
20	B02211-1	3	SWITCH, ROCKER, GREEN LIGHT	46	D13153	1	STAINLESS STEEL LANYARD
21	D010284	1	SWITCHPLATE	47	C00311	2	SCREW, 8-32 X 3/8
22	E010453	1	GASKET, SWITCHPLATE	48	K00666	1	90 ELBOW, SCHD 40, 1.5"

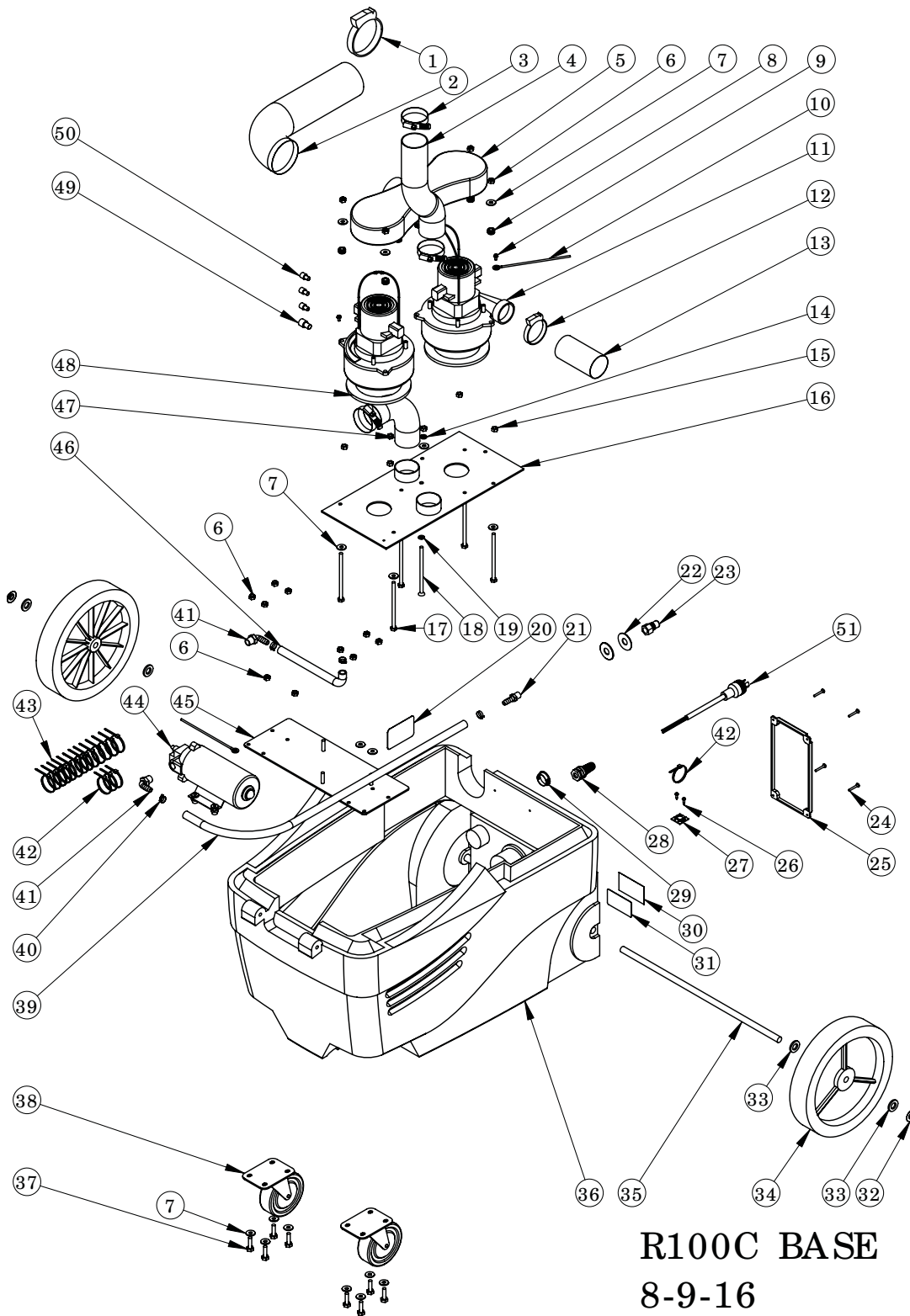

R100C BASE
8-9-16

BILL OF MATERIAL							
ITEM	PART NO.	QTY	DESCRIPTION	ITEM	PART NO.	QTY	DESCRIPTION
1	J13152	1	DOUBLE GRIP HOSE CLAMP	27	B00192	1	MOUNT, NYLON TIE
2	J11863	1	HOSE, 3 IN	28	B11606	1	STRAIN RELIEF, PIGTAIL
3	J00639	3	SCREW CLAMP, 1.63 - 2.43IN.	29	K10510	1	PLUG, 1.25 IN, BLACK
4	J00618	1	VACUUM HOSE, 2IN GREY, WIRE, 22 IN LG	30	H03545	1	COVER, SERIAL # LABEL
5	F11178-BLK	1	INTERCOOLER, , BLACK	31	H00565-5	1	LABEL, SERIAL NUMBER
6	C00273	16	LOCKNUT, 1/4 X 20, NYLON, SS	32	C02305	2	CAP NUT, .5IN PUSH-ON
7	C00233	22	WASHER, FLAT, .25 IN	33	C00240	4	WASHER, SHOULDER, NYLON
8	E00449	6	GROMMET	34	G11767	2	WHEEL, 10 IN
9	C00284	2	SCREW, 10-32 X .375	35	D11170	1	AXLE
10	B11150	2	GROUND WIRE,	36	F11789-MM	1	BASE
11	G00537	2	VACUUM MOTOR, 82 IN, 115 V	37	C00314-1	8	HEX BOLT, 1-4 X 20 X 1IN
12	J00657	1	HOSE CLAMP, 2 INSLDPRT	38	G03518-L	2	LOCKING CASTER, 4 IN
13	J00618	1	VACUUM HOSE, 2 IN GREY, WIRE, 4 IN LG	39	J00613B	1	SOLUTION HOSE, BLACK, 33 IN
14	C00254	1	LOCK WASHER, 1/4IN SPLIT	40	J11508	4	SCREW CLAMP #6, .43 TO
15	C00261	6	NUT, .25-20, HEX	41	A00054	2	ELBOW, 90, .375MP X .375B,
16	D11134-1	1	VAC PLATE	42	B00191	4	NYLON TIE, 11IN BLACK
17	C11189	5	SCREW, 1-4 X 20 X 4.5 IN,	43	B00190	13	NYLON TIE, 4IN
18	C11516	1	SCREW, 1-4 X 20 X 4.5 IN,	44	G13761	1	PUMP, 120 PSI, 115 V
19	C02312	1	LOCKWASHER, .25 IN., INTERNAL STAR	45	D11194	1	PUMP PLATE
20	H02564-2	1	LABEL, CAUTION, MOTOR HOUSING	46	J11154	1	SOLUTION HOSE, .375 X 14 IN, WIRE REINFORCED
21	A00060	1	.25 MALE X .375 BARB, BRASS	47	J00618	1	VACUUM HOSE, 2 IN GREY, WIRE, 7 IN LG
22	C11244	2	WASHER, .5 ID X 1,5 OD	48	E11169	2	GASKET, VAC MOTOR
23	A00104	1	QD, 1-4 M X 1-4 FP, BRASS	49	B00179-2	1	CLOSED END CNTR, 16-3
24	C11165,	4	SCREW, #8 X 1 IN, PAN, BLACK	50	B00179-1	3	CLOSED END CNTR, 16-3
25	F11790-MM	1	HEATER, TUNNEL COVER	51	B11779	1	12/3 TWIST LOCK PIGTAIL
26	C00293	2	#8 X .5IN PAN, BLACK SMS, PHILLIPS				

ELECTRICAL SYSTEM

PROBLEM	SOLUTION
NO ELECTRICAL POWER	<ol style="list-style-type: none"> 1. Defective power cord. 2. House or building circuit breaker tripped
POWER IS INTERMITTENT TO ONE OR ALL MOTORS	<ol style="list-style-type: none"> 1. Faulty electrical cable. 2. Defective switches. 3. Loose terminal or discolored terminal connections.

VACUUM SYSTEM

PROBLEM	SOLUTION
NO VACUUM SUCTION	<ol style="list-style-type: none"> 1. Drain Valve open. 2. Vacuum lid is not sealed against tank. 3. Loose vacuum hose, vacuum connection
LOW VACUUM SUCTION	<ol style="list-style-type: none"> 1. Accumulated dirt on lid screen. 2. Worn out vacuum lid gasket. 3. Lint & dirt build-up on wand head. 4. Defective vacuum hose. 5. Loose connection in the vacuum motor(s).

SOLUTION SYSTEM

PROBLEM	SOLUTION
PUMP MOTOR RUNS BUT NO SPRAY THROUGH SPRAY TIPS	<ol style="list-style-type: none"> 1. Clogged spray tips. 2. Clogged solution intake filter screen. 3. Clogged female quick disconnect coupler. 4. Quick disconnects not fully connected 5. Dirty or damaged pump head valves. 6. Defective pump check valve. 7. Crack in pump housing. 8. Lost Prime.
UNEVEN OR WEAK SPRAY FOR SPRAY TIPS	<ol style="list-style-type: none"> 1. Clogged or dirty spray tips. 2. Accumulated dirt on solution intake filter screen. 3. Accumulation of debris inside pump and plumbing. 4. Worn pump bearing (excessive noise). 5. Punctured pump diaphragm. 6. Defective rectifier or motor. 7. Worn nozzles.
ERRATIC PRESSURE	<ol style="list-style-type: none"> 1. Pump check valves defective or dirty 2. Lost prime.



Minuteman International Made Simple Commercial Limited Warranty

REVISION O EFFECTIVE 4/1/2016

Minuteman International, Inc. warrants to the original purchaser/user that the product is free from defects in workmanship and materials under normal use. Minuteman will, at its option, repair or replace without charge, parts that fail under normal use and service when operated and maintained in accordance with the applicable operation and instruction manuals. All warranty claims must be submitted through and approved by factory authorized repair stations.

This warranty does not apply to normal wear, or to items whose life is dependent on their use and care, such as belts, cords, switches, hoses, rubber parts, electrical motor components or adjustments. Parts manufactured by Minuteman are covered by and subject to the warranties and/or guarantees of their manufacturers. Please contact Minuteman for procedures in warranty claims against these manufacturers.

Special warning to purchaser -- Use of replacement filters and/or pre-filters not manufactured by Minuteman or its designated licensees, will void all warranties expressed or implied. A potential health hazard exists without original equipment replacement.

All warranted items become the sole property of Minuteman or its original manufacturer, whichever the case may be.

Minuteman disclaims any implied warranty, including the warranty of merchantability and the warranty of fitness for a particular purpose. Minuteman assumes no responsibility for any special, incidental or consequential damages.

This limited warranty is applicable only in the U.S.A. and Canada, and is extended only to the original user/purchaser of this product. Customers outside the U.S.A. and Canada should contact their local distributor for export warranty policies. Minuteman is not responsible for costs or repairs performed by persons other than those specifically authorized by Minuteman. This warranty does not apply to damage from transportation, alterations by unauthorized persons, misuse or abuse of the equipment, use of non-compatible chemicals, or damage to property, or loss of income due to malfunctions of the product.

If a difficulty develops with this machine, you should contact the dealer from whom it was purchased.

This warranty gives you specific legal rights, and you may have other rights which vary from state to state. Some states do not allow the exclusion or limitation of special, incidental or consequential damages, or limitations on how long an implied warranty lasts, so the above exclusions and limitations may not apply to you.

Model	Parts	Labor	Poly	Travel**
Cord Electric Group	5yrs	3yrs	12yrs	90 days
Battery Operated Group	5yrs	3yrs	12yrs	90 days

Exceptions.....

Model	Parts	Labor	Poly	Travel**
Port A Scrub, all models	1yr	6months	12yrs	90 days
A3S Blower	1yr	1yr	0	0
Phenom Dual Motor Upright Vacuums	2yrs	2yrs	0	0
Explosion Proof Vacuum	1yr	1yr	0	0
Propane Burnisher	1yr	1yr	0	90 days
**Travel, 2 hours max				

<i>Stand-alone Battery Chargers:</i>	One year
<i>Replacement Parts:</i>	Ninety days
<i>Batteries:</i>	0-3 months full replacement, 4-12 months pro-rate
<i>Polypropylene Plastic Tanks:</i>	12yr warranty, no additional labor

“Excellence Meets Clean”

**Minuteman is a Full Line Manufacturer of Sweepers and Scrubbers,
for Industrial Facilities.**

14N845 U.S. Route 20, Pingree Grove, IL 60140 USA
Phone (800) 323-9420 - www.minutemanintl.com
A Member of the Hako Group