



Electronic Service Manuals

This electronic document is provided as a service to our customers. We do not create the contents of the information contained in this document. Should you have detailed questions pertaining to the information contained in this document, you may contact Michco, or the manufacturer which provided the original information in this electronic deliverable. Michco's only part in this electronic deliverable was the electronic assembly process. By providing this manual on line we are not guaranteeing parts availability.

You may contact Michco through the following methods:

Phone (517) 484-9312 or (800) 331-3339

2011 N. High St. -- Lansing, Michigan -- 48906

Fax: (517) 484-9836

Email: CustServe@Michco.com

Web site: www.Michco.Com

Parts Web site: www.FloorMachineParts.Com

Order Parts on Line at:

www.FloorMachineParts.Com

Directly to Parts & Service:

By Email: **Shop@Michco.com**

By Fax: (517) 702-2041

By Voice: Use numbers above.

Serving the Cleaning Industry Since 1922

Notice: All copyrighted material remains property of original owners, all trademarks are property of respective owners. Manuals are subject to Manufacturer's reproduction limitations. Originals or reproductions were provided by manufacturers through a request. We make no warranty as to the correctness of information provided in this document and you assume all risk. By placing these manuals on line we are not declaring our corporation to be an manufacturer authorized dealer or provider, please check our web site for authorized manufacturers we represent.



Parts & Instruction Manual
C-Box 100, H-Box 200 & H-Box 500

Table of Contents

Technical specifications	3
Safety precautions	4
Grounding instructions	4
Machine components.....	5-6
Electrical requirements	6
Machine set-up	7
Operation	7
Draining recovery tank	7
Machine maintenance	8
Daily maintenance	8
Weekly maintenance	8
Storing the machine	8
Troubleshooting	9
Exploded views and part lists.....	10
Warranty	11

Your machine is furnished with this manual. This provides the necessary operation and preventative maintenance instructions. Operators must read and understand this manual before operating or servicing this machine.

Your machine was designed to give you excellent performance and efficiency. For best results and minimal cost, please follow the general guidelines below.

- Operate the machine with reasonable care.
- Follow the manufacturers suggested maintenance instructions as provided in this booklet.
- Use original Minuteman supplied parts.

TECHNICAL SPECIFICATIONS

Model	C100	H200	H500
Name	C-Box 100	H-Box 200	H-Box 500
Pump	100 psi on demand	200 psi on demand	500 psi on demand
Vac Motor	5.7" 3-stage vacuum	5.7" 3-stage vacuum	(2) 5.7" 2-stage vacuums
Vac Shut-off	Ball Float	Ball Float	Ball Float
Drain Valve	24" Hose	24" Hose	24" Hose
Vac Lift	137"	137"	140"
Heater	N/A	2,000 watt, in -line	2,000 watt, in -line
Capacity	15g Solution & 11g Recovery	15g Solution & 11g Recovery	15g Solution & 11g Recovery
Cord(s)	1, 12/3, 25 ft	2, 12/3, 25 ft	2, 12/3, 25 ft
Wheels	12"	12"	12"
Casters	4"	4"	4"
Weight	89 lbs.	98 lbs	116 lbs
Dimensions	36.75" H x 23.5" W x 32" L	36.75" H x 23.5" W x 32" L	36.75" H x 23.5" W x 32" L

Safety Precautions

This machine is intended for commercial use. It is designed to clean carpet and upholstery in an indoor environment, and it is not constructed for any other use. Use only recommended cleaning solutions and accessory tools.

All machine operators must read understand, and practice the following safety precautions.

The following safety alert symbols are used throughout this manual as indicated in their descriptions.

⚠ WARNING: to warn of hazards or unsafe practices that could result in severe personal injury or death.

FOR SAFETY: To identify actions that must be followed for safe operation of the equipment.

The following information signals potentially dangerous conditions to the operator or equipment.

FOR SAFETY

1. Do not operate the machine:
 - Unless trained and authorized
 - Unless this operator's manual has been read and understood
 - In flammable or explosive areas
 - Unless the power cords are properly grounded
 - If the machine is not in good operating condition
 - Outdoors
 - Where water is puddled
 - With an extension cord less than 12 GA
2. Before operating the machine:
 - Make sure all safety devices (floats, shut-offs, etc.) are in place and operating correctly
3. When using the machine:
 - Do not run the machine over the power cord(s)
 - Do not pull the machine by the cord
 - Do not pull the cord around sharp edges/corners
 - Do not unplug the machine by pulling on the cord
 - Do not stretch the cord
 - Keep the machine and the cord(s) away from hot surfaces
 - Do not handle the cord with wet hands
 - Report machine damage and/or faulty operation to your distributor

- follow mixing and handling instructions on chemical containers
4. Before leaving the machine or before servicing the machine:
 - Turn off all switches
 - Unplug the power cord(s)
 5. When servicing the machine:
 - Unplug the cord(s) from wall outlet(s)
 - Avoid all moving parts
 - Do not wear loose clothing
 - Use only manufacture's approved replacement parts.

⚡ WARNING: Hazardous voltage. Shock or electrocution can result. Always unplug the machine before servicing.

⚠ WARNING: Flammable materials and /or reactive metals can cause an explosion or fire. Do not pick up hot or flammable material.

Grounding Instructions

This machine must be grounded. If any part of the machine should malfunction or breakdown, electrical grounding provides a path of least resistance for electrical current. The power cord(s) on this machine have a grounding conductor and a ground prong on the cord end. The plug must be plugged into an appropriately grounded outlet that meets all local codes and ordinances. Do NOT remove the ground prong on the cord end; if the ground prong becomes damaged or broken, replace the power cord or cord end before use.

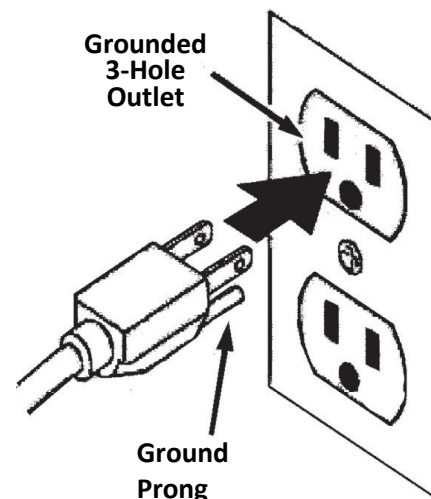

Machine Components

- A Recovery tank
- B Vacuum hose connection
- C Solution hose connection
- D Solution tank
- E Motor housing/base
- F Recovery Tank Lid
- G Switches
- H Power Cord Hanger

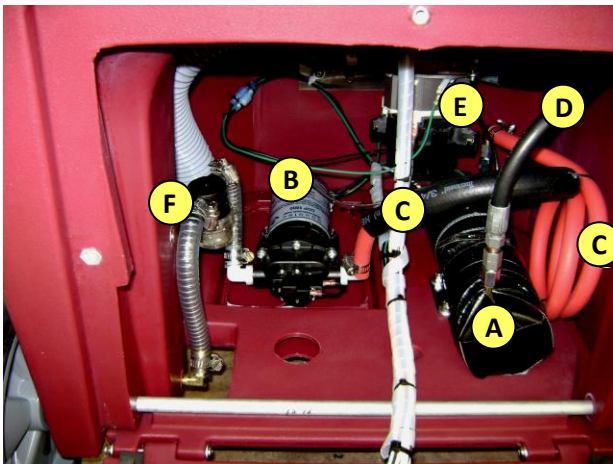
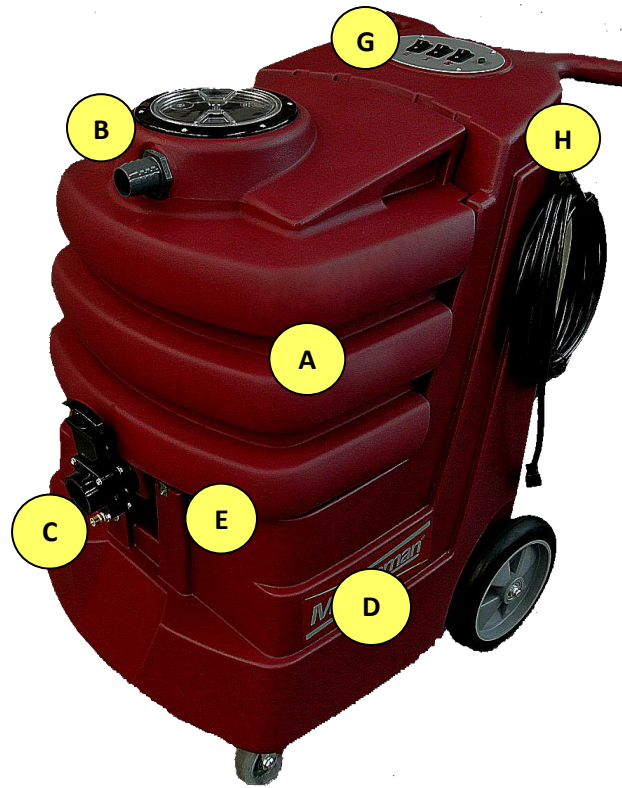

- A Heater (heated models only)
- B Pump, on demand
- C Pump outlet hose
- D Solution outlet hose
- E Vacuum motor
- F In-line filter

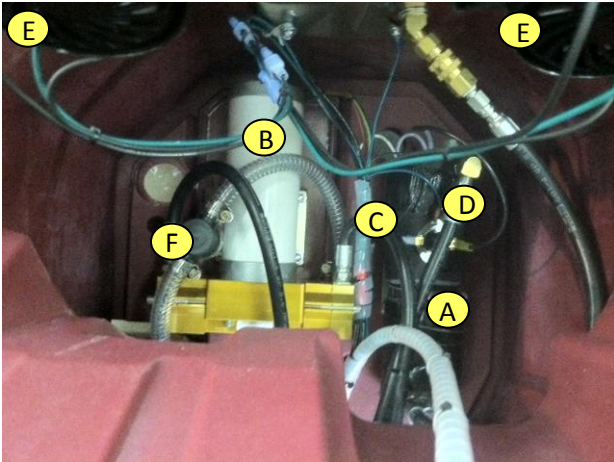

500 Model

- A Heater
- B Pump, on demand
- C Pump outlet hose
- D Solution outlet hose
- E Vacuum motors (2)
- F In-line filter



Electrical Requirements

Model C100 requires one 15 Amp -115Vac grounded outlet

Model H200 requires two – 115Vac grounded outlets

Model H500 requires two – 115Vac grounded outlets

Machine Set-Up

Pre-Operation

1. Carefully check the shipping carton for signs of damage. Report damage at once to the freight carrier.
2. The machine is shipped fully assembled and is ready for use.
3. Perform the machine Set-up Procedures.

Set-Up

1. Vacuum the carpet with a carpet cleaner and remove all other debris from the area.
CAUTION: do not use the carpet extractor as a vacuum cleaner.
2. Inspect the power cord(s) for damage.
3. Open the solution tank lid.
4. Fill the solution tank with premixed cleaning solution. Powdered chemicals are not recommended.

 **WARNING: Flammable materials can cause an explosion or fire. Never use flammable solutions or materials.**

FOR SAFETY: When using this machine, follow mixing and handling instructions on chemical containers.

5. Pull the trigger on the wand to release back pressure and attach the solution hose to the quick disconnect on the wand.
Note: ensure the quick disconnects snap together firmly. Do not use a damaged hose.
6. Attach the vacuum hose to the recovery tank.
7. Turn off all the machine switches.
8. Plug the machine's power cord(s) into a properly grounded wall outlet.

FOR SAFETY: Do Not operate the machine unless the cord is properly grounded and do not operate the machine with an extension cord less than 12 gauge and 3-wire and over 25 feet.
9. Connect the solution hose to the machine, and ensure that the quick disconnects snap together.
10. Turn on the pump switch.

11. Spray through the wand into a bucket or back into the solution tank until the spray is full and steady.
12. Turn on the heater (on machines with a built-in heater) and wait two minutes for the solution in the heater to get hot.
13. Turn on the vacuum(s) and begin cleaning.
NOTE: follow industry standards for spray and vacuum stroking.

Operation

1. Use pre-spray on heavily soiled areas.
2. Work away from the outlet and power cord(s) to prevent cord damage.
3. Use a recommended foam control solution in the recovery tank or on the carpet to prevent damage to the vacuum motor(s). Check for excessive foam in the recovery tank.
4. When the recovery tank is full of water, the ball float will stop the suction. When this happens, turn off the vacuum(s). **NOTE:** foam will not lift the ball float to shut off the suction when the tank is full, which can result in overflowing
5. Empty the recovery tank and fill the solution tank.

NOTE: when cleaning upholstery, always check the manufacturer's cleaning instructions.

Draining the Recovery Tank

1. Place a bucket under the drain valve on the front of the machine, or place the machine's drain valve over a drain.
2. Open the drain valve and allow the recovered water to flow out.

Removing Unused Solution

1. Rinse the recovery tank with clean water.
2. Close the drain valve and secure the recovery tank lid.
3. Remove the lid on the solution tank and place the vacuum hose into the tank.
4. Turn on the vacuum and suck the remaining solution into the recovery tank.
5. Drain the recovery tank into a clean bucket.

Machine Maintenance

Follow the maintenance schedule to keep the machine in good working condition.

FOR SAFETY: When servicing the machine, unplug the power cord(s) from wall outlet(s).

Daily

1. Empty and thoroughly rinse out both the solution and recovery tanks.
2. Wipe off the power cord(s) and inspect for damage. Repair or replace as necessary.
3. Coil the cord(s) neatly after use.
4. Clean the exterior of the machine with an all-purpose cleaner and a damp cloth. Protect the exterior with an automobile interior polish.

Weekly (or after approximately 20 hours of use)

1. Flush the solution system with a diluted descaler to dissolve normal chemical build-up:
 - a. Pour 2 gallons of warm water (less than 120 °F/ 49 °C) into the solution tank and add diluted descaler (dilute according to mixing instructions on the chemical package).
 - b. Turn on the heater (on machines with a built-in heater).
 - c. Turn on the pump and spray through the cleaning tool for 1 minute.
NOTE: hard water or chemical deposits that break up during descaling may become trapped at the spray tips. It is best to remove the spray tips from the tool and let them soak in the diluted descaler.
 - d. Turn off the heater and turn off the pump. Allow the chemical to sit in the machine for 2 hours.
2. Inspect the vacuum hose for holes and loose hose cuffs.

3. Inspect the spray pattern for clogged spray tips. If the tips are clogged, remove them and soak them in white vinegar for a few hours. Wash them out, but never push anything into the orifice in the spray tip to unblock it; the hole can become enlarged which would require replacement.
4. Inspect the solution hose and quick disconnects for leaks or damage. Lubricate the QDs with an all-purpose, water-resistant lubricant.
5. Lubricate the wheels and casters with an all-purpose, water-resistant oil.
6. Inspect the machine for water leaks and loose hardware. Repair/replace as necessary.
7. Remove the ball float and clean the screen.
8. Clean the in-line solution filter (refer to the exploded view of the machine for the location).

Machine Storage

1. Drain the machine completely of all liquid in the tanks.
2. Turn the pump on and spray until all the liquid is pumped out and air is evident.
3. Drain and dry the vacuum hose.
4. Leave the lid off the recovery tank.
5. Store the machine upright in a heated location.

Troubleshooting



Always unplug the machine before disconnecting or connecting any wires or components. Clean water spills immediately.

SYMPTOM	POSSIBLE CAUSE
Machine will not turn on	Power cord(s) not plugged in; Circuit breaker in the wall has tripped; Damaged power cord
No spraying pressure	Solution tank is empty; Spray tip is clogged; Pump is not running (see below); Clogged in-line solution filter; Disconnected, dirty or damaged quick disconnect
Pump not running	No power to pump – no power in cord, bad on/off switch; Bad pump motor; NOTE: the 100 and 200 psi pumps only run while spraying; Tripped circuit breaker
Low vacuum suction	Recovery tank lid not on tight; Drain valve is open or seals are worn; Dirty vacuum inlet screen around ball float; Vacuum hose is loose or cracked; Internal vacuum hose is loose or cracked; Only one vacuum motor (on machines with two motors) is running
No vacuum suction	Recovery tank is full and ball float has risen to shut off the vacuum; Vacuum is not running – bad on/off switch, bad vac motor, tripped circuit;
Low heat <i>(heated models only)</i>	Spraying too long and exhausting the heated water; Machine needs to be descaled
No heat <i>(heated models only)</i>	No power to heating element – thermal cutout is blown; Bimetallic switch is not closing; Heat on/off switch is bad; Circuit breaker has tripped

Contact your distributor for additional information or to arrange for service.
Always use original equipment replacement parts.

C-Box 100, H-Box 200 & H-Box 500

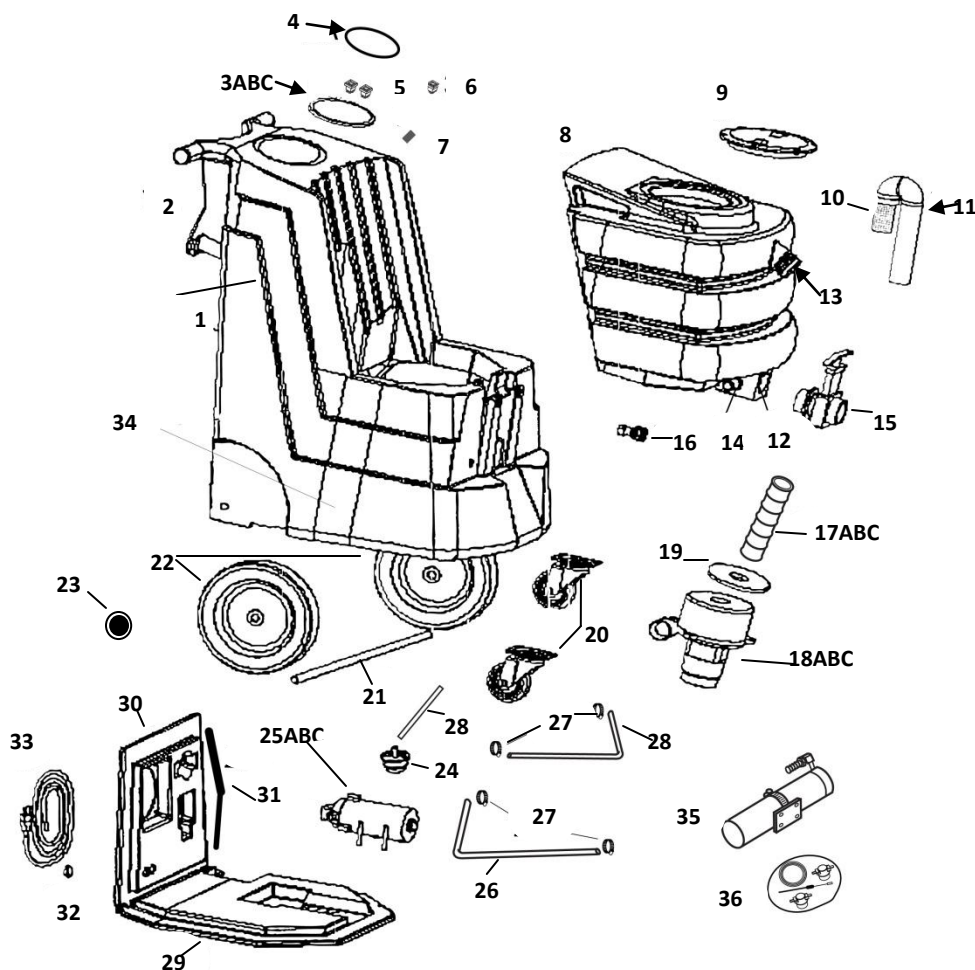

Item	Part No.	Qty	Description
1	121317	1	Holding tank/Base
2	121300	2	Power cord hanger
3A-B	121318	1	Switch plate
3C	121336	1	Switch plate (500 Model)
4	121319	1	Gasket, switch plate
5	121301	1	Plug on no-heat (Not 500 Model)
6	121320	1	Switch 2 HP
7	121340	1	Indicator, neon green
8	121321	1	Recovery tank
9	121302	1	Lid and ring, recovery tank
10	121322	1	Ball float holder
11	121303	1	Ball float
12	121323	1	Access plate
13	121324	1	Hose barb for vac hose
14	121325	2	Bracket, recovery tank
15	121326	1	Drain valve, recovery tank
16	121304	1	Quick disconnect, male
17A-B	121327	1	Hose, wire reinforced, 24"
17C	121341	1	Hose, wire reinforced 34.5" (500 Model)
18A-B	121305	1	Vacuum motor, 3-stage (100 & 200 Models)
18C	121338	2	Vacuum motor, 2 stage (500 Model)

Item	Part No.	Qty	Description
19	121306	1-2	Gasket, Vacuum
20	121307	2	Caster
21	121328	1	Axle
22	121308	2	Wheel, 10"
23	121309	2	Axle cap
24	121310	1	Filter, in-line
25A	121311	1	Pump, 100 psi
25B	121312	1	Pump, 200 psi
25C	121339	1	Pump, 500 psi
26	121329	1	Hose, pump outlet, 48"
27	121330	6	Hose clamp
28	121331	2	Hose, pump inlet, 8"
29	121332	1	Pallet, bottom
30	121333	1	Pallet back
31	121334	1	Gasket, 40"
32	121313	1-2	Retainer, cord
33	121314	1-2	Power cord
34	121335	2	Decals
35	121315	1	Heater, complete
36	121316	1	Heater repair kit
37	121337	1	Pressure Gauge (500 model), not shown

**REVISION G
EFFECTIVE 12/1/2011**

Minuteman International, Inc. warrants to the original purchaser/user that the product is free from defects in workmanship and materials under normal use. Minuteman will, at its option, repair or replace without charge, parts that fail under normal use and service when operated and maintained in accordance with the applicable operation and instruction manuals. All warranty claims must be submitted through and approved by factory authorized repair stations.

This warranty does not apply to normal wear, or to items whose life is dependent on their use and care, such as belts, cords, switches, hoses, rubber parts, electrical motor components or adjustments. Parts manufactured by Minuteman are covered by and subject to the warranties and/or guarantees of their manufacturers. Please contact Minuteman for procedures in warranty claims against these manufacturers.

Special warning to purchaser — Use of replacement filters and/or prefilters not manufactured by Minuteman or its designated licensees, will void all warranties expressed or implied. A potential health hazard exists without original equipment replacement.

All warranted items become the sole property of Minuteman or its original manufacturer, whichever the case may be.

Minuteman disclaims any implied warranty, including the warranty of merchantability and the warranty of fitness for a particular purpose. Minuteman assumes no responsibility for any special, incidental or consequential damages.

This limited warranty is applicable only in the U.S.A. and Canada, and is extended only to the original user/purchaser of this product. Customers outside the U.S.A. and Canada should contact their local distributor for export warranty policies. Minuteman is not responsible for costs or repairs performed by persons other than those specifically authorized by Minuteman. This warranty does not apply to damage from transportation, alterations by unauthorized persons, misuse or abuse of the equipment, use of non-compatible chemicals, or damage to property, or loss of income due to malfunctions of the product.

If a difficulty develops with this machine, you should contact the dealer from whom it was purchased.

This warranty gives you specific legal rights, and you may have other rights which vary from state to state. Some states do not allow the exclusion or limitation of special, incidental or consequential damages, or limitations on how long an implied warranty lasts, so the above exclusions and limitations may not apply to you.

Cord Electric Group: Three years parts, two years labor, ninety days travel (Not to exceed two hours)

Exceptions.....

Model	Parts	Labor	Poly	Travel
Port A Scrub	1 yr	6 months	10 yrs	0
MPV 13	1 yr	0	0	0
MPV 14 & 18	2 yrs	1 yr	0	0
Phenom Upright Vacuums	1 yr	1yr	0	0
Rapid Air Blower	1 yr	1 yr	10 yrs	0
Explosion Proof Vacuum	1 yr	1 yr	0	0
X12, X12H & TRS 14	1 yr	1 yr	10 yrs	0
E17 & E20 Electric Scrubbers	1 yr	6 months	10 yrs	0
Pneumatic Vacuums	3 yr	1 yr	0	0
Description	Parts	Labor	Poly	Travel
Battery Operated Group	3 yrs	2 yrs	10	90 days
Sweepers	1 yr	1 yr	10	90 days
Internal Combustion Group	1 yr	1 yr	10	90 days
Exception: PAS 14B	1 yr	1 yr	10 yr	0

Battery Chargers: One year replacement
 Replacement Parts: Ninety days
 Batteries: 0-3 month replacement, 4-12 month pro-rate
 Polyethylene Plastic Tanks: Tanks have 10yr warranty, no additional labor