



Electronic Service Manuals

This electronic document is provided as a service to our customers. We do not create the contents of the information contained in this document. Should you have detailed questions pertaining to the information contained in this document, you may contact Michco, or the manufacturer which provided the original information in this electronic deliverable. Michco's only part in this electronic deliverable was the electronic assembly process. By providing this manual on line we are not guaranteeing parts availability.

You may contact Michco through the following methods:

Phone (517) 484-9312 or (800) 331-3339

2011 N. High St. -- Lansing, Michigan -- 48906

Fax: (517) 484-9836

Email: CustServe@Michco.com

Web site: www.Michco.Com

Parts Web site: www.FloorMachineParts.Com

Order Parts on Line at:

www.FloorMachineParts.Com

Directly to Parts & Service:

By Email: **Shop@Michco.com**

By Fax: (517) 702-2041

By Voice: Use numbers above.

Serving the Cleaning Industry Since 1922

Notice: All copyrighted material remains property of original owners, all trademarks are property of respective owners. Manuals are subject to Manufacturer's reproduction limitations. Originals or reproductions were provided by manufacturers through a request. We make no warranty as to the correctness of information provided in this document and you assume all risk. By placing these manuals on line we are not declaring our corporation to be an manufacturer authorized dealer or provider, please check our web site for authorized manufacturers we represent.



Parts Manual
H20 Floor Scrubber
Disc Brush Drive

Technical Specifications

Model **H20**

Model No. H20BD / H20BDCE / H20BDQP / H20BDQPG

	H20
Current (Max)	32 amps
Battery Capacity (Lead Acid)	105Ah @20 hr
Battery Capacity (Gel)	95Ah @20 hr
Sound Level	65.5 dBA
Cleaning path width	20 in (51 cm)
Squeegee width	33 in (84 cm)
Theoretical productivity (Brush Drive)	15,000 ft ² /hr (1,394 m ²)
Working speed (Brush Drive)	1.7 mph (2.7 km per hr)
Rated voltage	24 volts
Vacuum flow	65 cfm (110 m3/hr)
Vacuum waterlift	46 inches (112mbar)
Vacuum power	.60 HP (450 W)
Brush type	Disc
Brush motor(s) power	3/4 HP (560W)
Number of brushes	1
Brush RPM	180 RPM
Aqua-Stop equipped	Coming Soon
Solution capacity	12 Gal (45 liters)
Recovery capacity	13 Gal (49 liters)
Working Grade	2%
Weight with batteries	313 lbs (142 kg)
Weight without batteries	203lbs (92 kg)
Dimensions (LxWxH)	47.4 x 21.3 x 42.3 (120.4 x 54.1 107.4 cm)

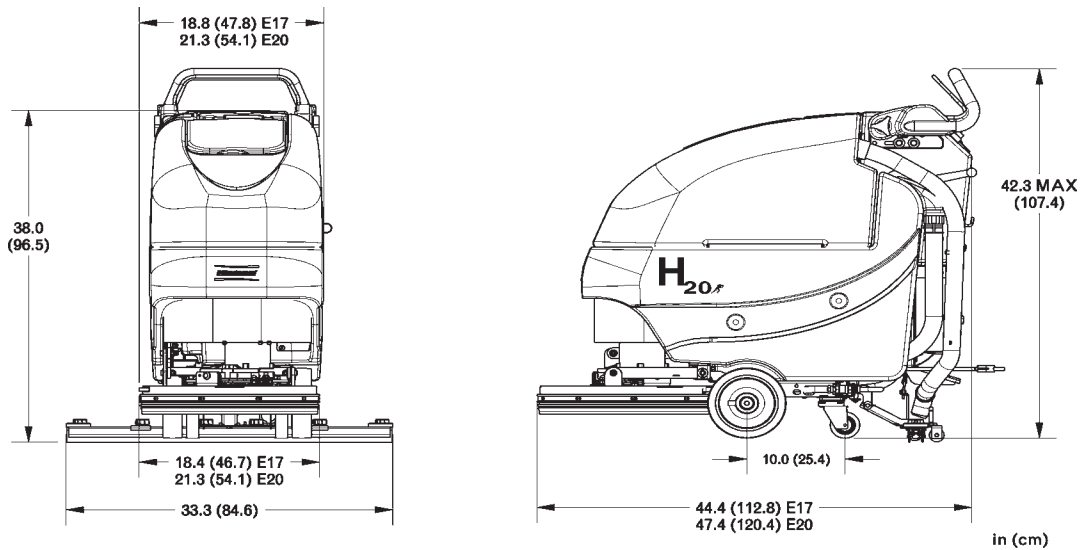

For Safety When Servicing or Maintaining Machine

- Stop on level surface.
- Disconnect the power to the machine by pulling the red Battery Connector located under the recovery tank near the batteries.
- Avoid moving parts. Do not wear loose jackets, shirts, or sleeves when working on machine.
- Avoid contact with battery acid. Battery acid can cause burns. When working on or around batteries, wear protective clothing and safety glasses. Remove metal jewelry. Do not lay tools or metal objects on top of batteries.
- Do not clean machine with a pressure washer.
- Authorized personnel must perform repairs and maintenance. Use Minuteman supplied replacement parts.

Table of Contents

Main Assembly	1
Main Assembly BOM	2
Brush Drive Base Assembly	3
Brush Drive Base Assembly BOM	4
Base Assembly	5
Chassis Assembly	6
Chassis Assembly BOM	7
Solution Valve Assembly	8
Solution Tank Assembly	9
Lift Pedal Stop Assembly	10
Recovery Tank Assembly	11
Recovery Tank Assembly BOM	12
Handle Assembly	13
Battery Tray Assembly	14
Electrical Box Assembly	15
Electrical Box Assembly BOM	16
Electrical Box Cover Assembly	17
Vacuum Motor Assembly	18
20" Brush Deck Assembly	19
20" Brush Deck Assembly BOM	20
Brush Hub Assembly	21
Rear Squeegee Assembly	22
Squeegee Mechanism Assembly	23
Wiring Diagrams	24
WARRANTY	27

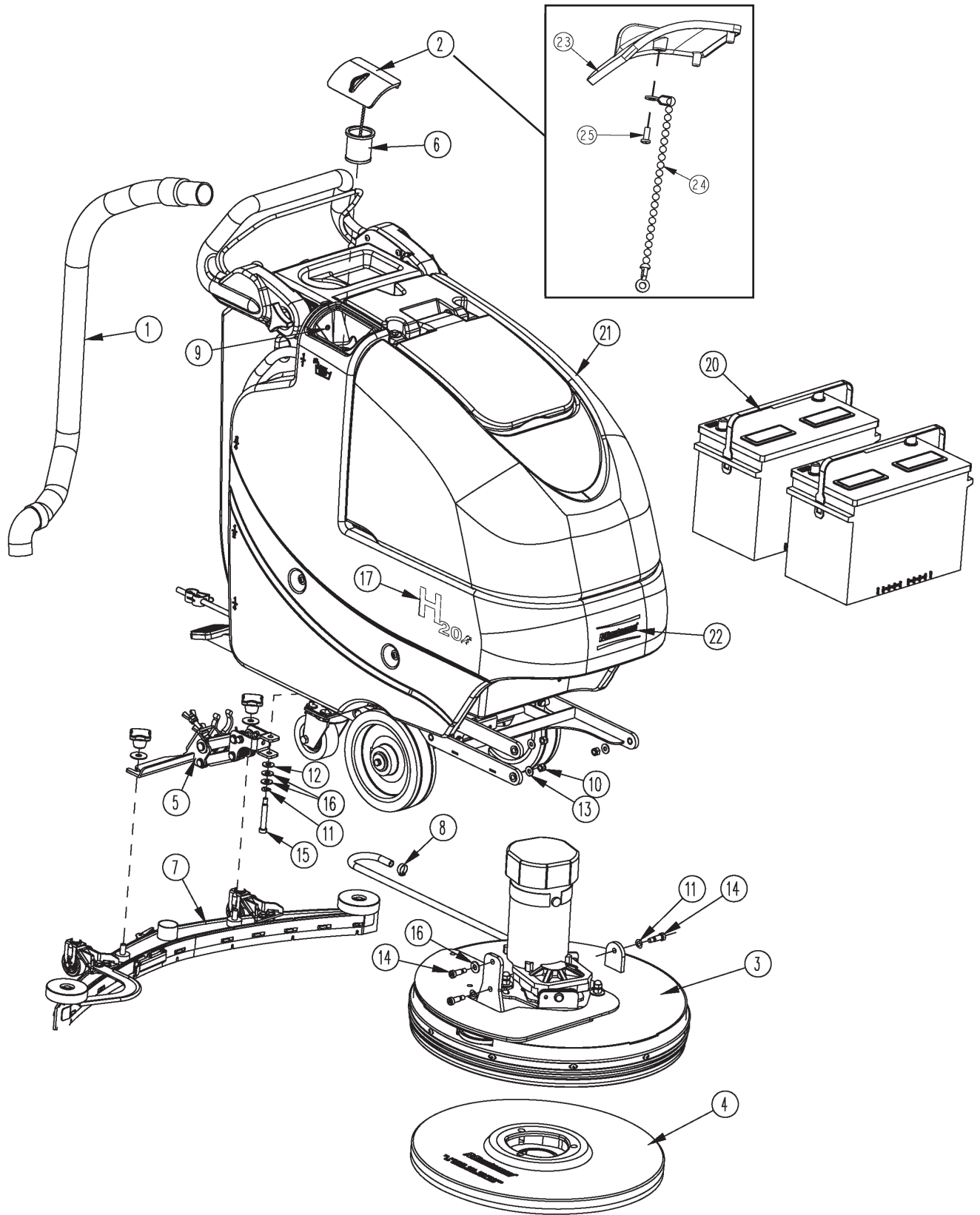

BILL OF MATERIAL - 120/230			
ITEM	PART NO.	REQ'D	DESCRIPTION
1	172010	1	HOSE, CLEAR VAC W/ 45 CUFF
2	172018	1	SOLUTION TANK LID ASSY
3	172100	1	BRUSH DECK ASSY 20"
4	172120-2	1	20" PAD DRIVER - 120V
4CE	172520-2	1	20" PAD DRIVER - 230V
5	172150	1	SQUEEGEE LIFT MECH ASSY
6	172159	1	FILTER, FILL PORT, ES1720
7	172270	1	SQUEEGEE, 34" (860)
8	450076	1	CLAMP-CRIMP 185R SS
9	711118	1	SCR-ST-A 10 X .75 SS
10	711374	3	NUT-NYLOC 5/16-18
11	711523	3	WSR-WAVE .37X .68 X .08
12	711569	1	WSR-FLT .390 X .880 X .062 NYL
13	711575	3	WSR-FLT .31x.75x.06ST
14	712081	3	SHOULDER BLT 5/16-18 X 3/8 X .75
15	712143	1	BLT-SHLD 3/8 X 2.0, 5/16-18
16	712301	3	WSR-FLAT .37 X .87 X .06
17	715684	2	DECAL, H2O
18	740164-1	1	JUMPER CABLE ASSY, RED 4G 12"
19	747649	1	CABLE ASSY, BATTERY E17
20	956712	2	BATTERY, 12V 115AH
20G	956100	2	GEL BATTERY 12V 100AH
21	172001BD-120	1	E20 BRUSH DRV MAIN ASSY-120V CHARGER
21CE	172001BD-230	1	E20BRUSH DRV BASE ASSY-230V CHARGER
22	715914W	1	DECAL, MINUTEMAN W/SWOOSHES, WHITE
23	172008	1	SOLUTION TANK LID
24	172123	1	CHAIN, BEADED SS W/ EYELETS
25	712145	1	SCR-MC 6-32 X .37 PPH SS

OPTIONAL BRUSHES		
ITEM	PART NO.	DESCRIPTION
4.1	172520-1	BRUSH, 20" NYLON
4.2	172520-3	BRUSH, 20" POLY GRIT
4.3	172520-6	DISC BRUSH 20", SCRUB GRIT 2, 120GR RED

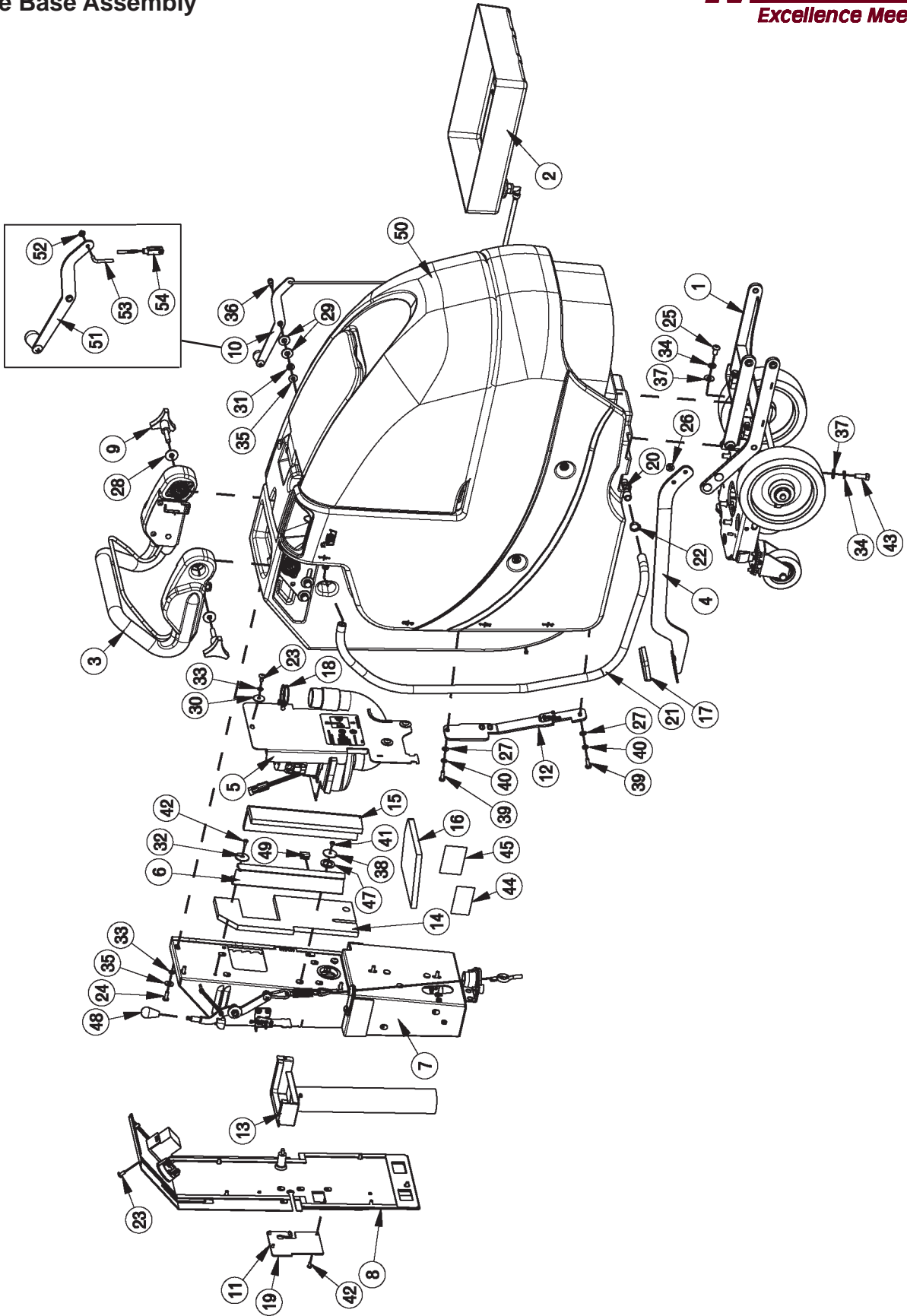

Brush Drive Base Assembly BOM



BILL OF MATERIAL - 172001BD-120/230

ITEM	PART NO.	REQ'D	DESCRIPTION	ITEM	PART NO.	REQ'D	DESCRIPTION
1	172002	1	E17 BD CHASSIS ASSY	29	711508	2	WSR-FLAT .44X 1.0X .08
1A	172002-1	1	E20 BD CHASSIS ASSY	30	711519	3	WSR- FLAT .25 X 1.01 X .06
2	172012	1	BATTERY TRAY ASSY	31	711523	1	WSR-WAVE .37X .68 X .08
3	172016	1	E1720 BD HANDLE ASSY	32	711543	1	WSR-HELICAL #10
4	172032	1	LIFT PEDAL WMT	33	711544	9	WSR-HELICAL 1/4
5	172050	1	VAC MOTOR ASSY	34	711546	6	WSR-HELICAL 3/8
6	172055	1	BKT, VAC AREA INSIDE COVER	35	711575	6	WSR-FLT .31x.75x.06ST
7	172070-120	1	ELEC BOX BD ASSY 120V	36	711803	1	COTTER PIN
7CE	172070-230	1	ELEC BOX BD ASSY 230V	37	712041	1	BLT- SHLDR .31 X .375 X 1/4-20
8	172073	1	BD ELEC BOX COVER ASSY	38	712117	1	CLEVIS PIN 3/16
9	172085	2	KNOB, 3/8-16 STUD, 3 LOBE	39	712301	6	WSR-FLAT .37 X .87 X .06
10	172112	1	SOL CONTROL ASSY	40	712312	2	WSR-FLAT .187 X 1.25
11	172129	1	BKT, PWR CORD MOUNT	41	712562	2	BOLT-HH 1/4-20X3/4 SS
12	172157	1	LIFT PEDAL STOP ASSY	42	712683	2	NUT, HEX 5/16-18 NYLOC SS
13	172179	1	CHARGER INLET ASSEMBLY	43	712758	2	WSR-HELICAL 1/4 SS
14	172184	1	FOAM COVER, REAR 1	44	712772	2	WSR-FLAT .344 x .75 x .06 SS
15	172185	1	FOAM COVER, REAR 2	45	712800	1	SCR-MC 10-24 X .25 ST PL
16	172187	1	FOAM COVER, FRONT 2	46	712810	5	SCR-MC 10-24 X .37 ST PL
17	210142	1	PEDAL PAD	47	713042	4	BLT-HH 3/8-16 X 1 #5
18	260203	1	WIRE GRIP HOSE CLAMP	48	715029	1	DECAL-NAME PLATE SERIAL
19	293080	1	STRAIN RELIEF-HEYCO 1207	49	715047	1	DECAL-CLEAR LAMINATE 2X3
20	342440	1	FITTING, TEE 3/4MPT 1/2BARB	50	715950	1	LABEL, PATENT NUMBERS
21	430156	1	HOSE, 1/2 X 42 CLEAR	51	717025	1	WSR-FLAT 13/16ID X 1.25 X .08
22	450093	2	CRIMP CLAMP 3/4" STEPLESS	52	760592	1	KNOB, OVAL TAPERED
23	710177	1	SCR-MC 1/4-20 X .37 ST PL	52A	172299	1	KNOB, 5/16-18 X 1-1/2 X 3" B.I
24	710178	10	SCR-MC 1/4-20 X .50 TRUSS STPL	53	809443	1	CLIP-WIRE & CORD
25	710380	5	SCR-MC RD HD 1/4-20 X .75 STL PL	54	172001BASE	1	E1720 BASE ASSY
26	710985	2	SCR-SC 3/8-16 X .62 ST PL	55	172115	1	SOL CNTRL LEVER ASSY
27	711504	2	WSR-FLAT 1/4 ID SS	56	172122	1	NUT, PUSH-ON WSR CAP, 3/16
28	711507	2	WSR-FLAT .37 X 1.12 X .06	57	172069	1	ROD, SOL. CTRL, ES1720
				58	172062	1	YOKE, 3/16 CLEVIS, 10-32, LONG

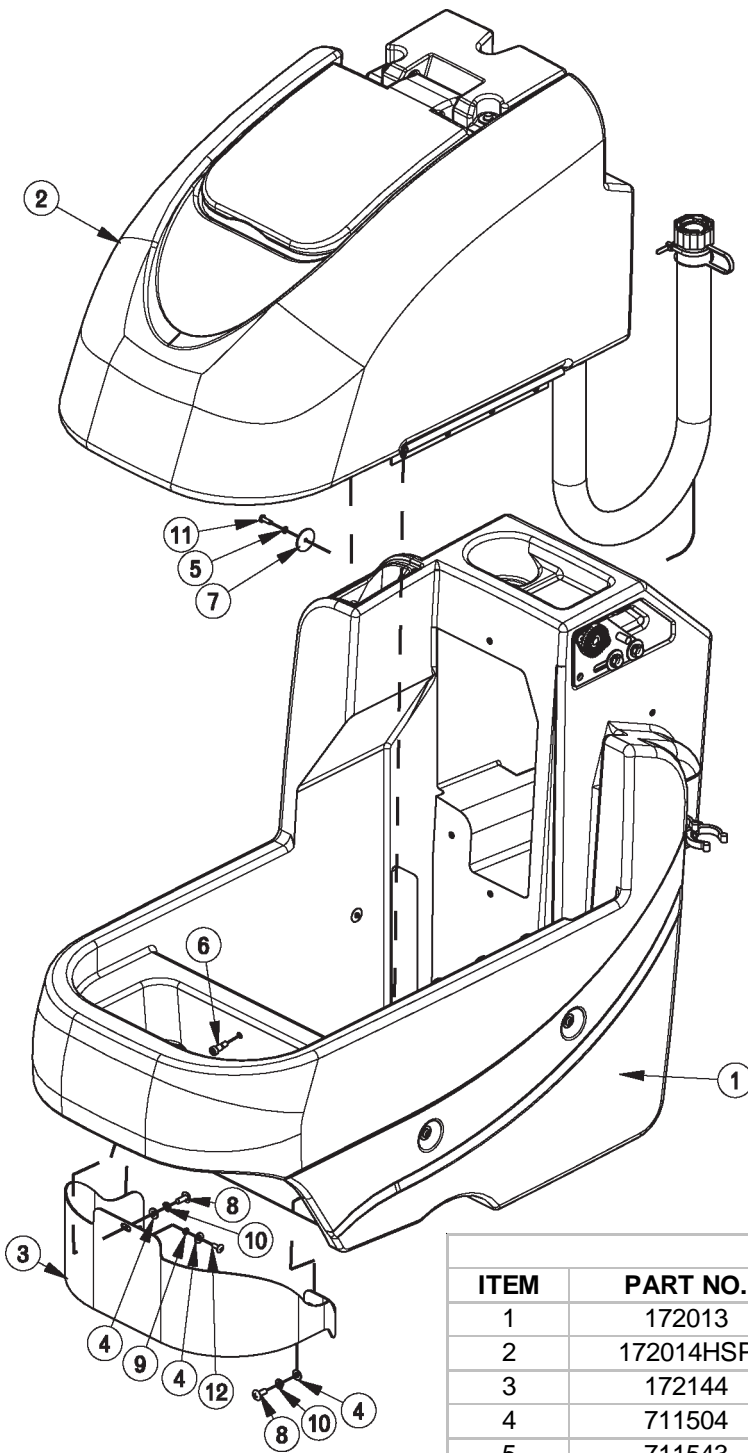

BILL OF MATERIAL - 172001BASE			
ITEM	PART NO.	REQ'D	DESCRIPTION
1	172013	1	SOL TANK ASSY, E1720
2	172014HSP	1	REC TANK ASSY
3	172144	1	PANEL, FRONT 1720
4	711504	3	WSR-FLAT 1/4 ID SS
5	711543	4	WSR-HELICAL #10
6	712041	1	BLT- SHLDR 1/4-20 X .44 X .37
7	712312	4	WSR-FLAT .187 X 1.25
8	712565	2	SCR-MC 1/4-20X.63 SS TR HD
9	712757	1	WSR - HELICAL #10 SS
10	712758	2	WSR-HELICAL 1/4 SS
11	712812	4	SCR-MC 10-24 X .62 PPH ST PL
12	712822	1	SCR-MC TR HD 10-24 X .50 SS

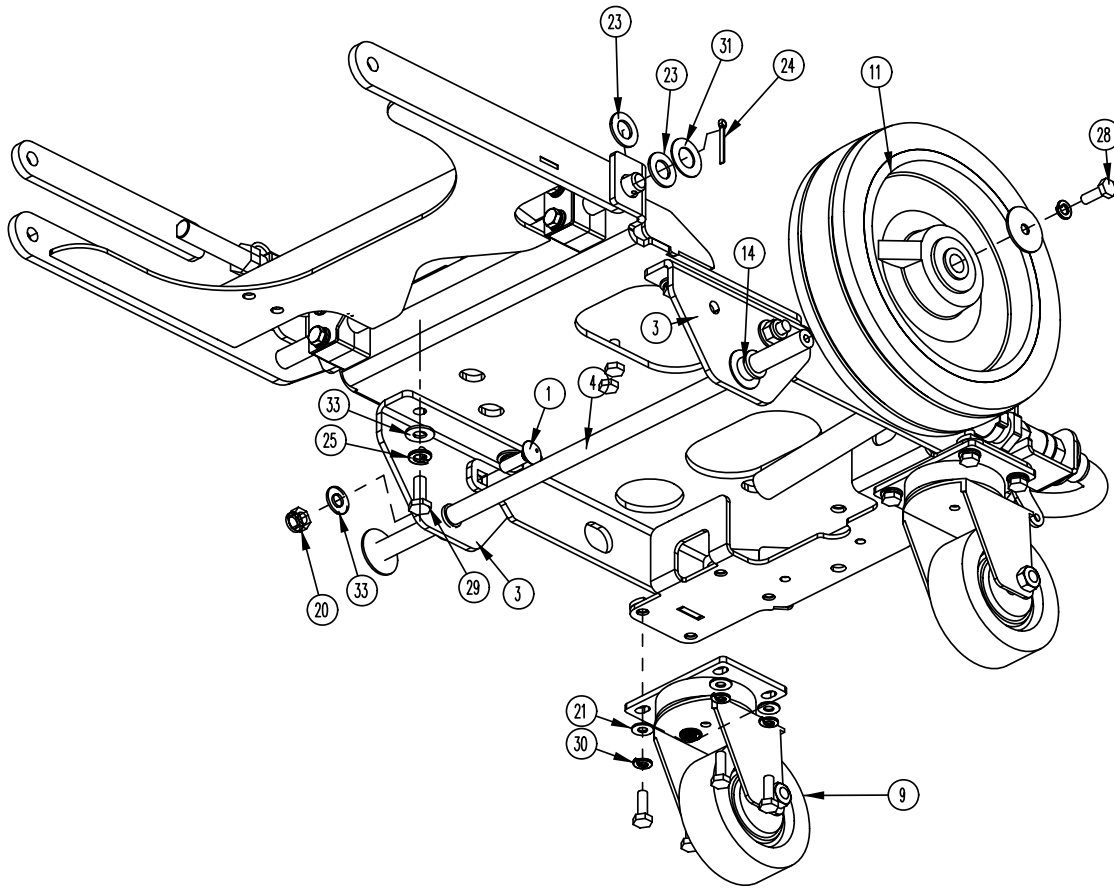
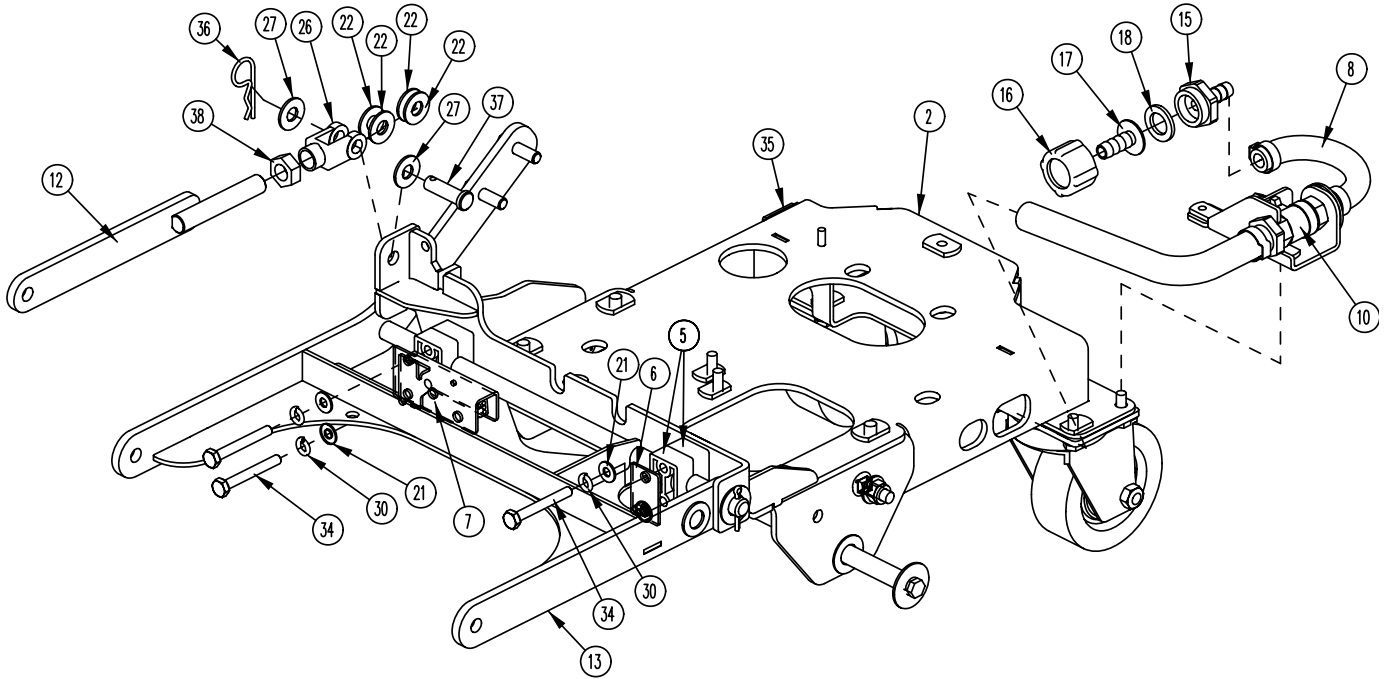

BILL OF MATERIAL - 172002-1			
ITEM	PART NO.	REQ'D	DESCRIPTION
1	70-516-16	2	BLT-CAR 5/16-18 X 1.00 ZP
2	172020	1	MAIN FRAME WMT
3	172024	2	WHEEL BRACKET
4	172035	1	WHEEL ROD
5	172038	4	BEARING BLOCK
6	172039	1	BEARING BLOCK PLATE
7	172110	1	DECK SWIT CH ASSY
8	172164	1	HOSE-WIRE REINF 3/8 X 5.5"
9	172167	2	CASTER, 3-1/2 POLYURETHANE
10	172264	1	SOLUTION VALVE ASSY
11	172265	2	WHEEL, 8 X 2 X .5, 75A
12	172368	1	UPPER LIFT ARM
13	172370	1	DISC DECK LIFT WMT
14	260041	2	OILITE FLANGE BUSHING
15	342441	1	FITTING, MGHT X 3/8HB PP
16	342442	1	FITTING, FGHT NUT PP
17	342443	1	FITTING 3/8HB INSERT PP
18	342444	1	WSR-FILTER, GARDEN HOSE SIZE
19	450076	2	CLAMP-CRIMP 185R SS
20	711374	2	NUT -NYLOC 5/16-18
21	711504	12	WSR-FLAT 1/4 ID SS
22	711569	4	WSR-FLT .390 X .880 X .062 NYL
23	711592	2	WSR-FLAT .506 X .9 X .064 NYL
24	711809	1	COTTER PIN, 1/8 X 1.0
25	712140	4	WSR-HELICAL 5/16 SS
26	712265	1	CLEVIS-YOKE, 1/2-20 W/ .375 PIN
27	712301	2	WSR-FLAT .37 X .87 X .06
28	712562	12	BOLT-HH 1/4-20X3/4 SS
29	712575	4	BLT-HH 5/16-18 X .75 SS
30	712758	14	WSR-HELICAL 1/4 SS
31	712760	3	WSR-FLAT .56X1.06X.04 SS
32	712761	2	WSR-FLAT .28 X 1.25 X .059SS
33	712772	6	WSR-FLAT .344 x .75 x .06 SS
34	713007	4	BLT-HH 1/4-20 X 2 #5
35	809444	1	CLIP-CORD
36	833374	1	PIN, HAIRPIN COTTER 3/8
37	833833	1	PIN-CLEVIS 3/8 X 1.25
38	3400449	1	NUT -HEX JAM 1/2-20 ZP

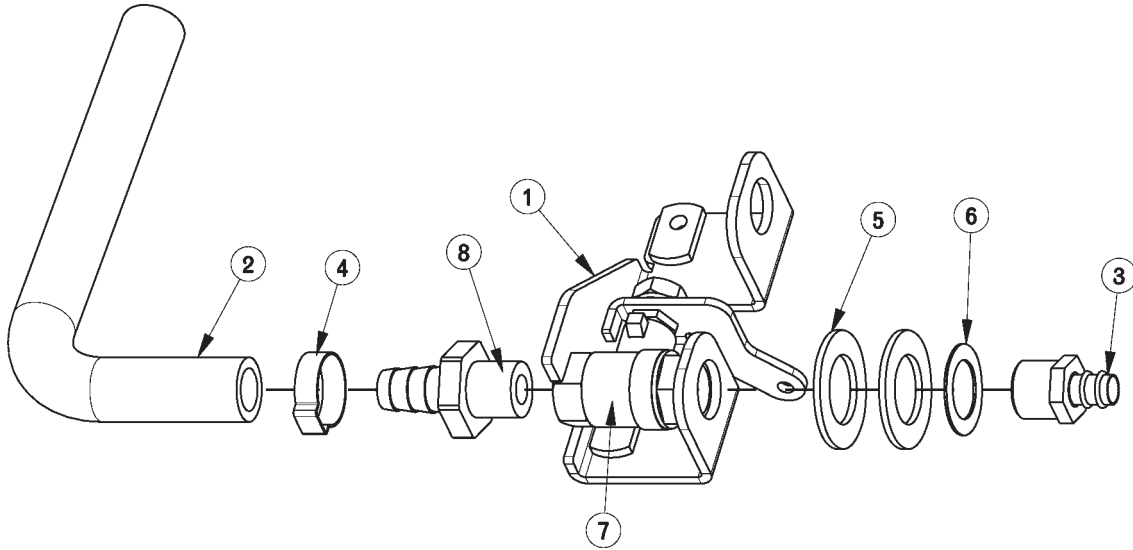

BILL OF MATERIAL - 172064			
ITEM	PART NO.	REQ'D	DESCRIPTION
1	172063	1	BKT, SOL VALVE MOUNT
2	172158	1	HOSE, 1/2"ID X 7.5" NYLOBRAID
3	320265	1	FITTING DUBL 3/8HBx3/8MPT
4	383347	1	CRIMP CLAMP 1/2 HOSE SS 185R
5	711512	2	WSR-FLAT .75X1.37X.08
6	711513	1	WSR-FLAT .69 X 1.06 X .03 SS
7	809415	1	VALVE, 3/8 FPT, 45 OPEN/CLOSE
8	827008	1	FITTING, 3/8 MPT 1/2 HOSE

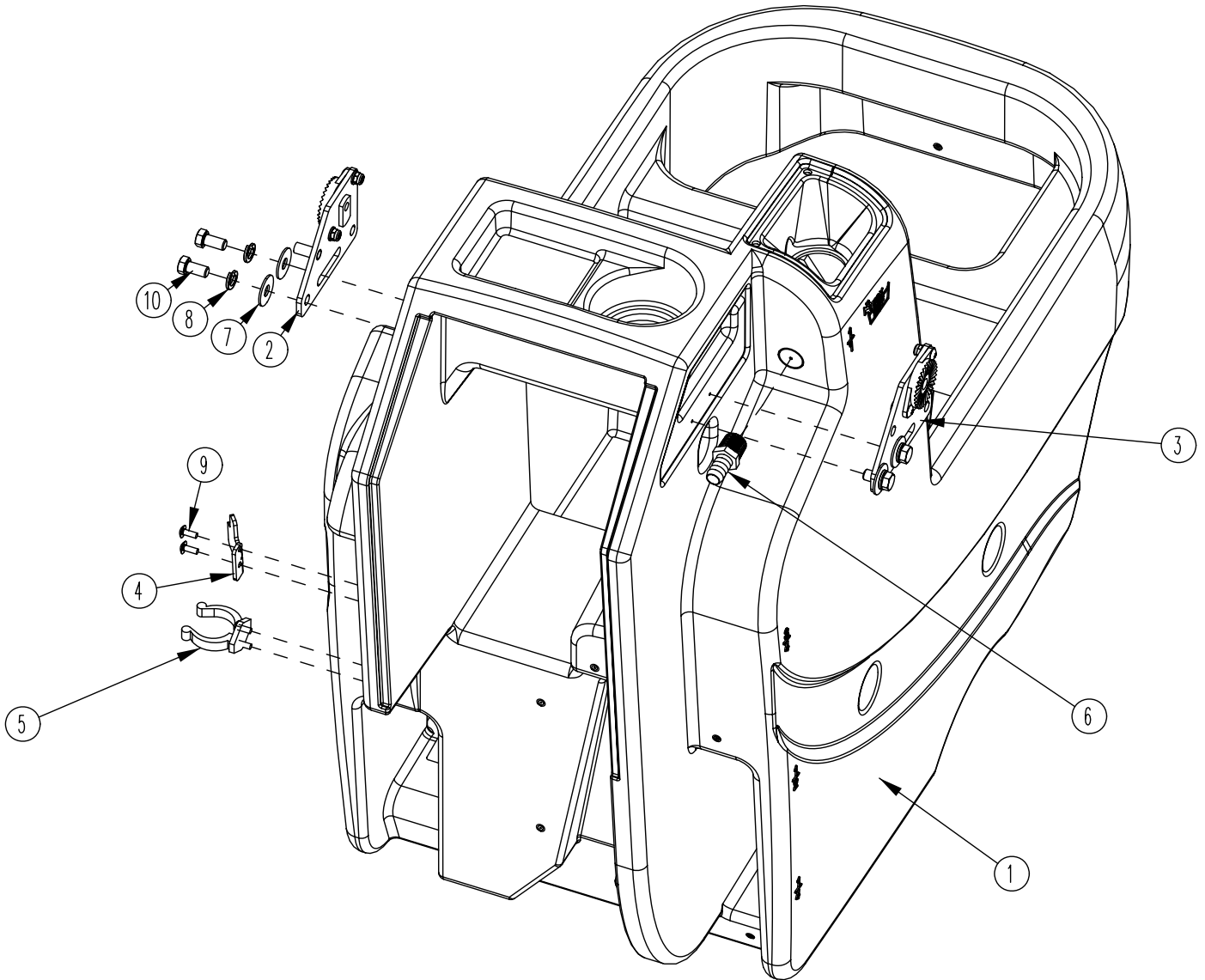

BILL OF MATERIAL - 172013			
ITEM	PART NO.	REQ'D	DESCRIPTION
1	172003	1	SOLUTION TANK, E1720
2	172080	1	HANDLE MOUNT ASSY, LEFT
3	172082	1	HANDLE MOUNT ASSY, RIGHT
4	172341	1	HOOK, DRAIN HOSE WITH TWIST VALVE
5	260579	1	TOOL CLIP, 1.5" HOSE
6	342438	1	FITTING, 1/2 MPT 1/2 HB BRASS
7	711507	4	WSR-FLAT .37 X 1.12 X .06
8	711546	4	WSR-HELICAL 3/8
9	712822	4	SCR-MC TR HD 10-24 X .50 SS
10	713041	4	BLT-HH 3/8-16 X 3/4 #5

Lift Pedal Stop Assembly

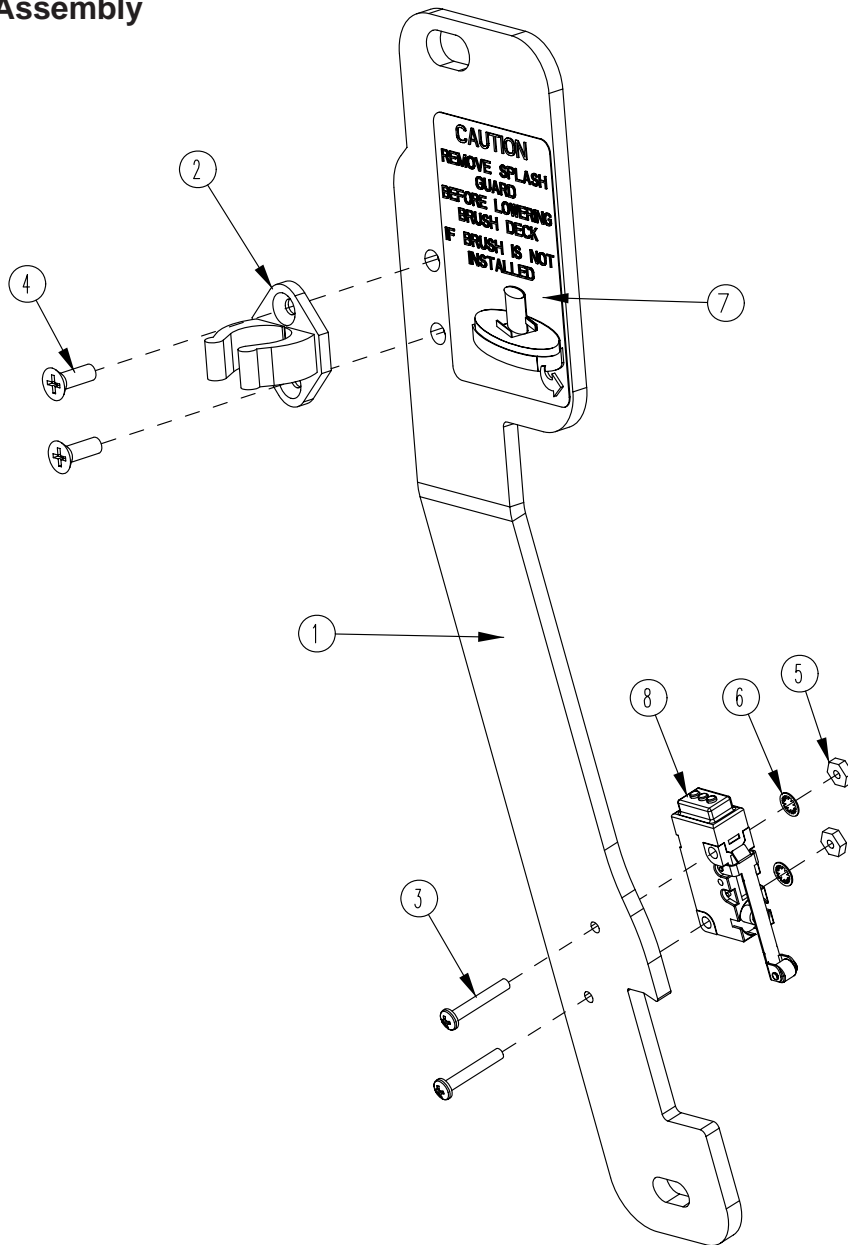

BILL OF MATERIAL - 172157			
ITEM	PART NO.	REQ'D	DESCRIPTION
1	172036	1	BKT , PEDAL STOP
2	172065	1	CLIP, FOR 1/2" ID HOSE
3	710493	2	SCR-MC 4-40 X .75 PAN HD
4	710530	2	SCR-MC FL HD 8-32 X .50 BRS
5	711428	2	NUT-HEX 4-40
6	712326	2	WSR-INT LOCK #4
7	715685	1	DECAL, REMOVE SPLASH GUARD
8	747603-2	1	SWIT CH ASY, MICRO ROLLER W/PACK/CONDUIT

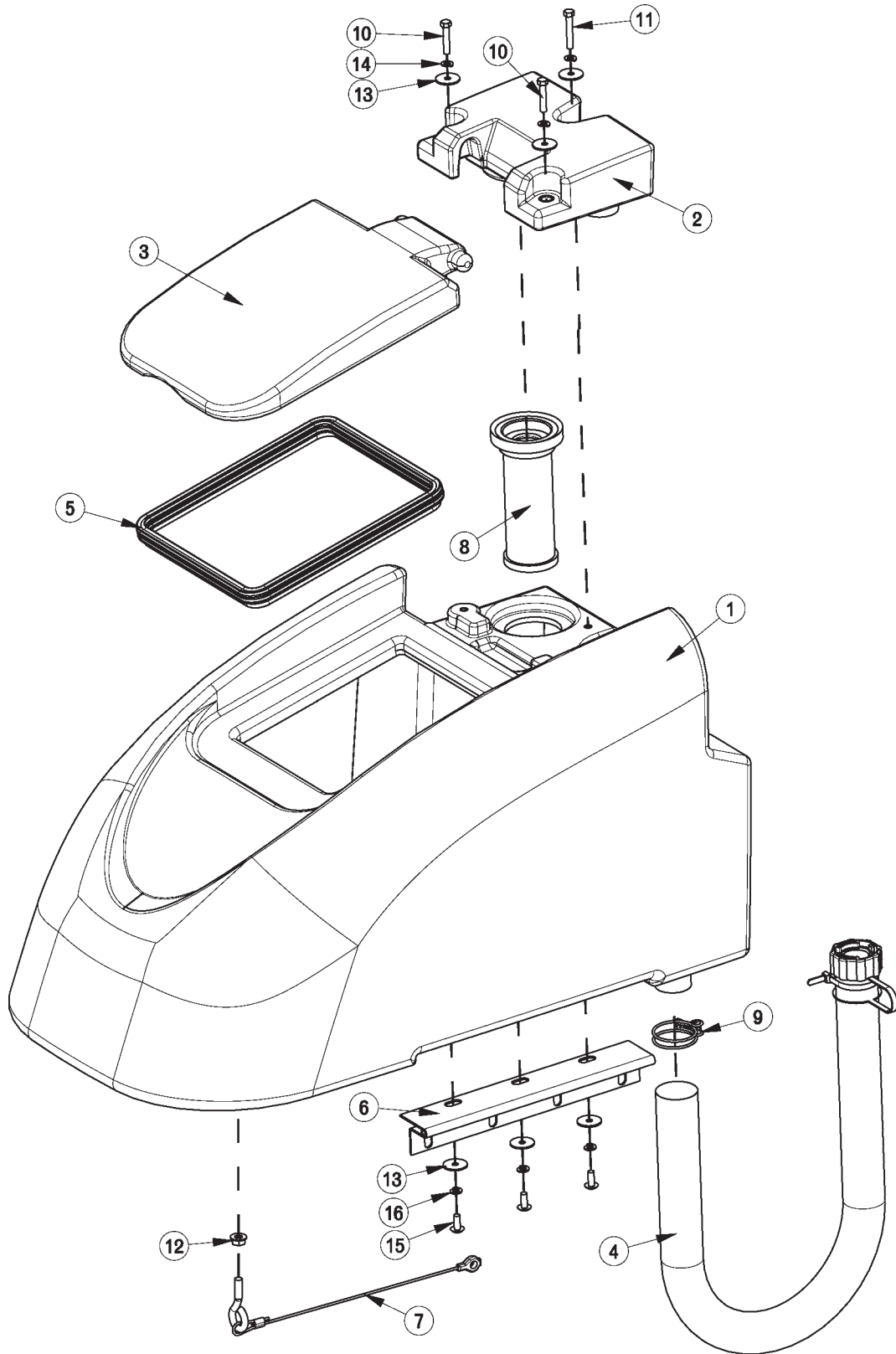

BILL OF MATERIAL - 172014HSP			
ITEM	PART NO.	REQ'D	DESCRIPTION
1	172004HSP	1	ES1720 RECOVERY TANK
2	172005HSP	1	ES1720 VACUUM MANIFOLD
3	172007	1	ES1720 LID
4	97090096	1	DRAIN HOSE ASSY, RECOVERY TANK
5	172017	1	GASKET, LID
6	172049	1	HINGE, RECOVERY TANK
7	172394	1	REC TANK CABLE ASSY 11.625
8	172132	1	SCREENED FLOAT
9	172329	1	CLAMP-HOSE 1.56" 102122 MURRAY
10	711210	2	BLT-HH 1/4-20 X 1.25 STPL
11	711212	1	BLT-HH 1/4-20 X 1.50 STPL
12	711379	1	NUT, FLANGED WIZZ 5/16-18
13	711519	6	WSR- FLAT .25 X 1.01 X .06
14	711544	3	WSR-HELICAL 1/4
15	712565	3	SCR-MC 1/4-20X.63 SS TR HD
16	712758	3	WSR-HELICAL 1/4 SS

Handle Assembly

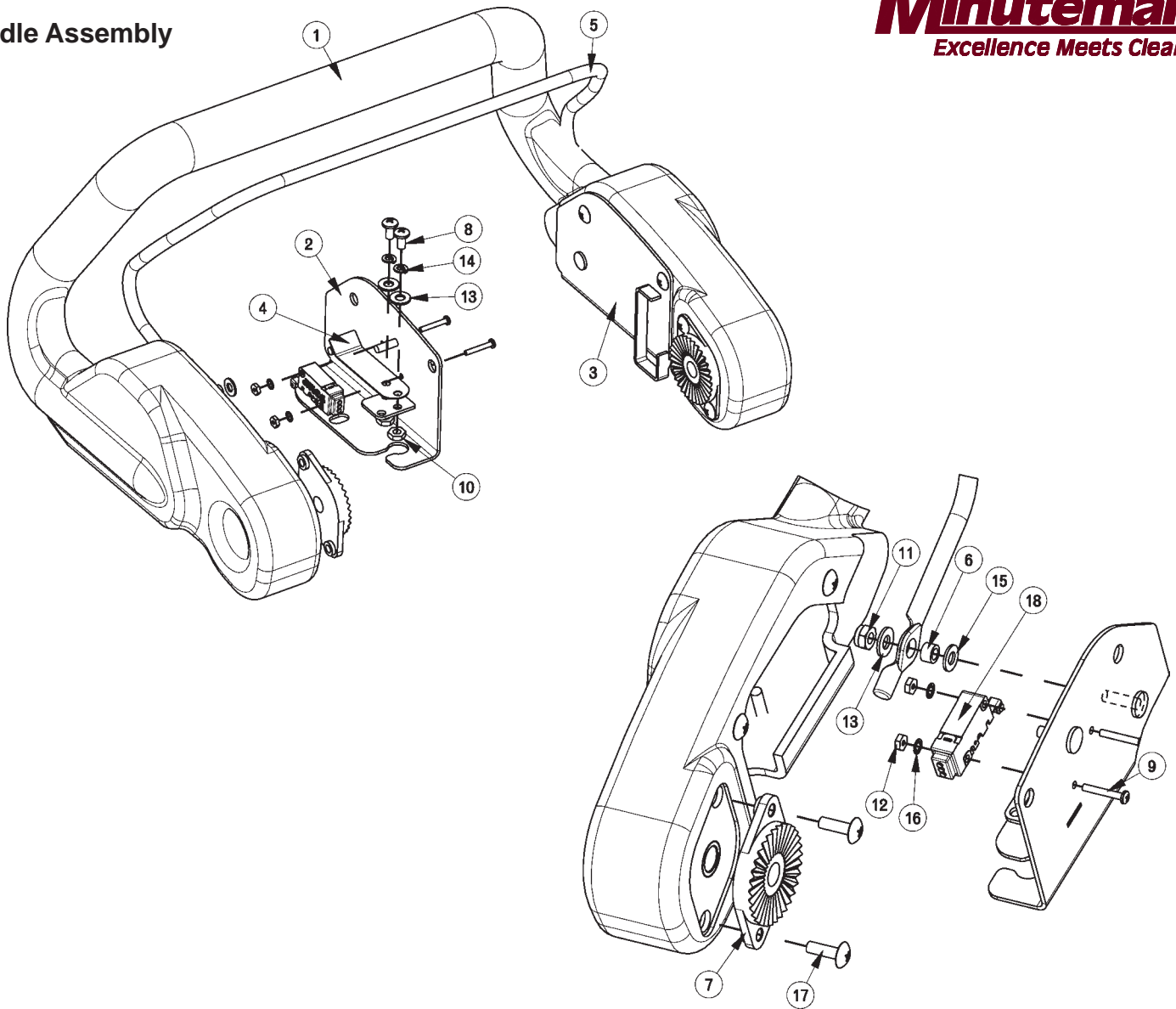

BILL OF MATERIAL - 172016

ITEM	PART NO.	REQ'D	DESCRIPTION
1	172006	1	ES1720 HANDLE
2	172053	1	BAIL PLATE WMT RH
3	172054	1	BAIL PLATE WMT LH
4	172057	2	ES1720 LEAF SPRING
5	172059	1	ES1720 BAIL, HANDLE
6	172074	2	SPACER, 5/16OD X 17GA, ALUM
7	270143	2	HANDLE PIVOT JAW
8	710353	4	SCR-MC RD HD 10-32 X .37 STL
9	710493	2	SCR-MC 4-40 X .75 PAN HD
10	711310	4	NUT, HEX 10-32 ST PL
11	711350	2	NUT-NYLOC 10-32
12	711428	2	NUT-HEX 4-40
13	711503	6	WSR, FLAT#10
14	711543	4	WSR-HELICAL #10
15	712320	2	WSR-NYLON .22 X .45 X .04
16	712326	2	WSR-INT LOCK #4
17	712830	10	SCR-MC 10-24 X .62 STLZ TR HD
18	747603-1	1	SWITCH ASY, MICRO ROLLER W/PACK/CONDUIT
19	747632	1	CABLE ASY, 5 COND 18G CONSOLE

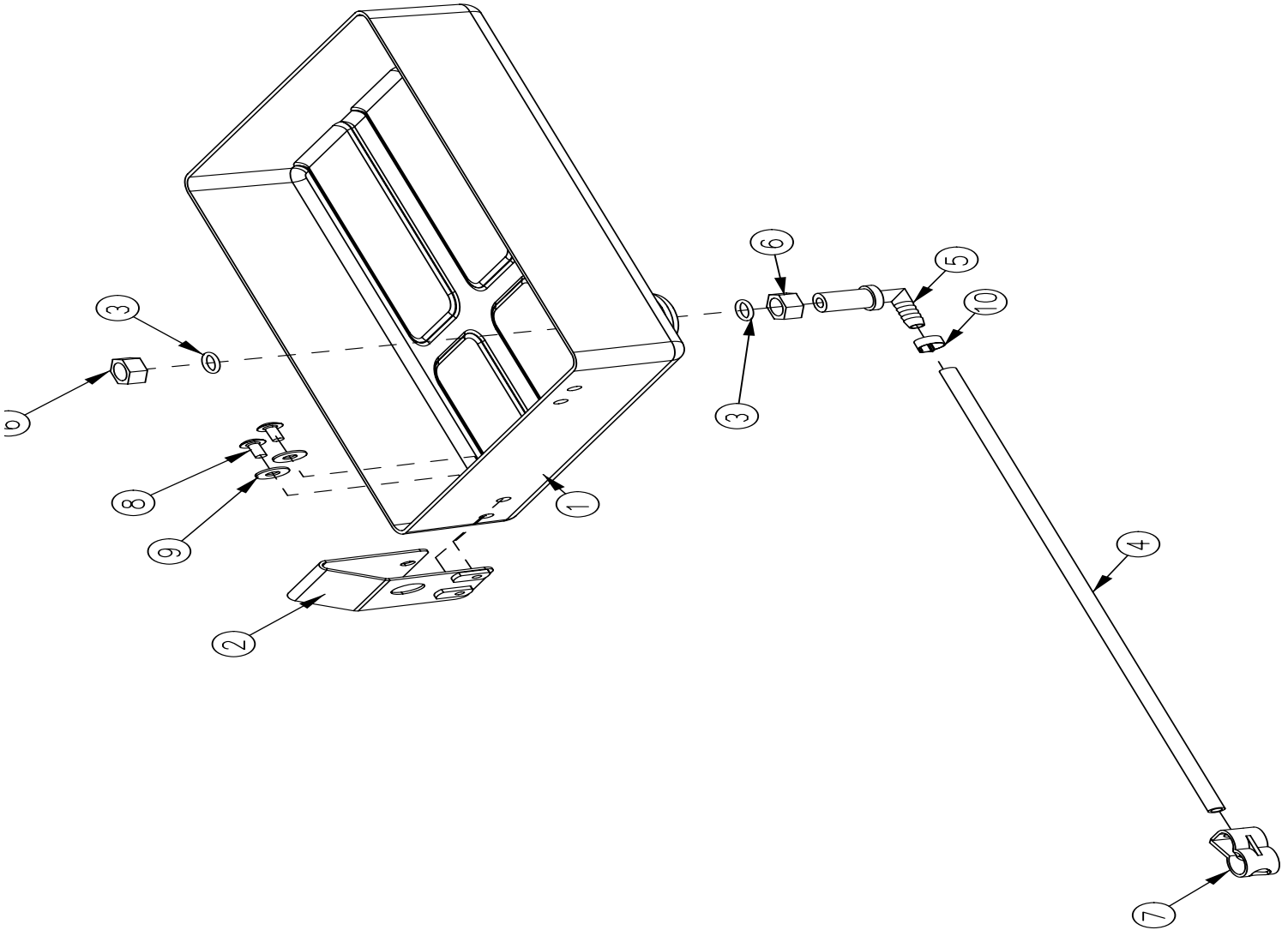

BILL OF MATERIAL - 172012			
ITEM	PART NO.	REQ'D	DESCRIPTION
1	172116	1	ES1720 BATTERY BOX
2	172213	1	BKT, SPACER FOR BATTERIES
3	210414	2	O RING 2-113
4	260224	1	18" HOSE
5	320271	1	NOZZLE BODY-ELBOW
6	320272	2	NOZZLE BODY LOCKNUT
7	320273	1	HOSE SHUT-OFF CLAMP
8	710178	2	SCR-MC 1/4-20 X .50 TRUSS STPL
9	711575	2	WSR-FLT .31x.75x.06ST
10	828490	1	CRIMP CLAMP 140R

Electrical Box Assembly

For machines with curved Squeegee

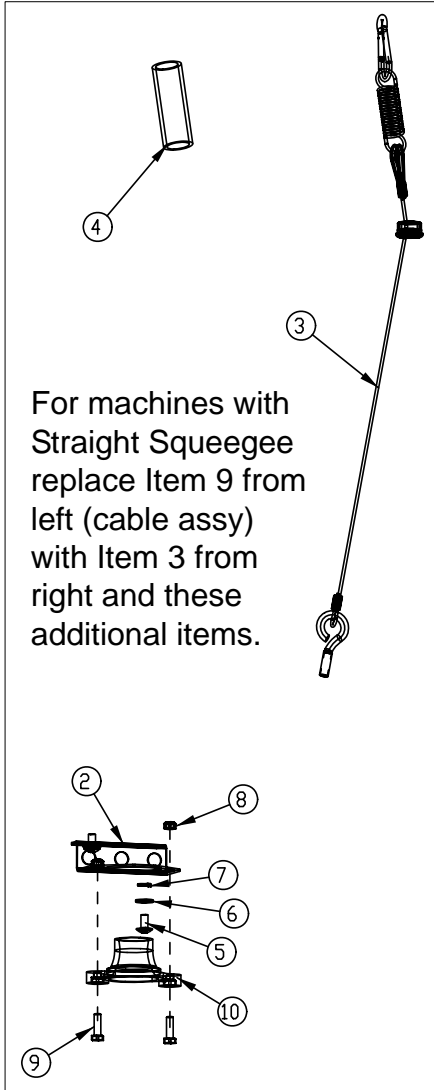
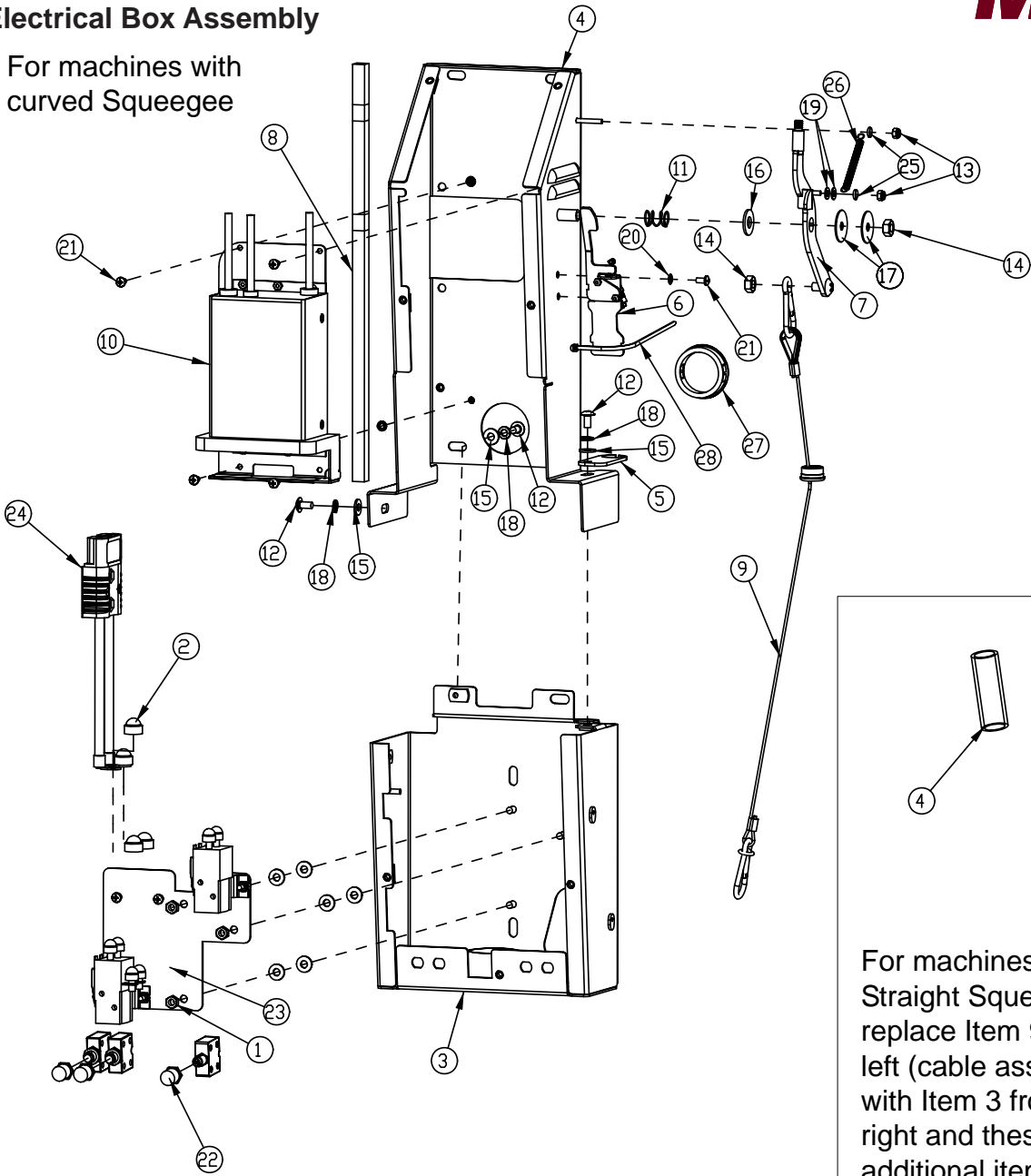

BILL OF MATERIAL - 172070-120/230-C				
ITEM	PART NO.	REQ'D	DESCRIPTION	NOTES
1	369-416	3	NUT-HEX 1/4-20 NYLOC SERATED	
2	15592033_CAP	2	CAP, SAFETY NUT COVER M8	
3	172077	1	ELEC BOX-BOT HALF WMT	
4	172088	1	ELEC BOX-TOP HALF WMT	
5	172107	1	BKT , UPPER BUSHING MOUNT	
6	172141	1	VAC SWIT CH ASSY	
7	172152	1	VAC LEVER WMT	
8	172188_	1	FOAM TAPE, 1/2" SQ X 16.5"	
9	172381	1	CABLE ASSY, SQUEEGEE LIFT	
10	172385	1	E1720 120V CHARGER ASSEMBLY	
10CE	957753	1	E1720 230V CHARGER ASSEMBLY	USED UNTIL 04/2010
10CE	172360	1	E1720 230V CHARGER ASSEMBLY	USED AFTER 04/2010
11	670093	1	SPRING, COMPRESSION	
12	710178	3	SCR-MC 1/4-20 X .50 TRUSS STPL	
13	711372	2	NUT-NYLOC 8-32 STL ZINC	
14	711383	2	NUT-HEX CLR LOC 5/16-18	
15	711505	9	1/4 FLAT WASHER, STEEL	
16	711508	1	WSR-FLAT .44X 1.0X.08	
17	711516	2	WSR- FLAT .31 X 1.25 X .05	
18	711544	3	WSR-HELICAL 1/4	
19	712320	2	WSR-NYLON .22 X .45 X .04	
20	712770	6	WSR INT LOCK #10A SS	
21	712810	6	SCR-MC 10-24 X .37 ST PL	
22	742748	3	CIRCUIT BREAKER BOOT	
23	747630	1	ELEC PANEL ASSY, E1720BD	
24	747637	1	WIRE ASY, MACHINE-BAT TERYE1720	
25	760134	2	MOUNT RING	
26	762084	1	SPRING-EXT .25OD X 2" F.L. MUSIC	
27	762400	1	HEYCO BUSHING 2.00"	
28	828062	1	CABLE TIE LARGE	

For machines with **Straight Squeegee**
 Replace Cable Assembly and reference these additional parts

BILL OF MATERIAL				
ITEM	PART NO.	REQ'D	DESCRIPTION	
1	000719	1	PACER-ISL 90	
2	172128	1	BKT , LOWER BUSHING MOUNT	
3	172149	1	CABLE ASSY, SQUEEGEE LIFT	
4	172331	1	PIPE, 3/4 X 3.0 SCHD 40 PVC	
5	710178	2	SCR-MC 1/4-20 X .50 TRUSS STPL	
6	711505	2	1/4 FLAT WASHER, STEEL	
7	711544	2	WSR-HELICAL 1/4	
8	717018	2	NUT-NYLOC M6 X 1.0	
9	717022	2	BOLT-HH M6X1.0 X 20	
10	90508391	1	BUSHING, CABLE GUIDE, HAKO	

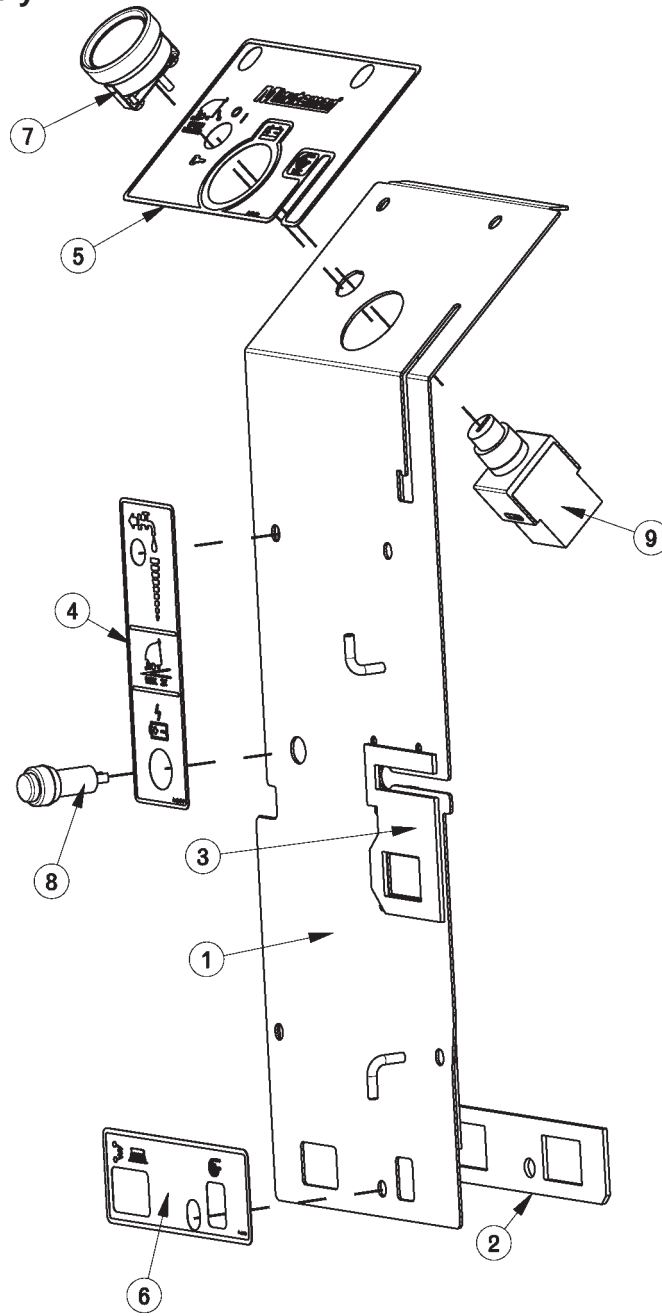

BILL OF MATERIAL - 172073			
ITEM	PART NO.	REQ'D	DESCRIPTION
1	172181	1	ELEC BOX, COVER, WMT
2	172193	1	GASKET, CB OUTLINE
3	172194	1	GASKET, CHARGER CORD PLATE
4	715672	1	DECAL, 1720 BD ELEC BOX
5	715673	1	DECAL, 1720 BD DASHBOARD
6	715675	1	DECAL, BD CIRC BKRS
7	740216	1	VOLT METER
8	747614	1	CHARGE STATUS INDICATOR
9	747617-1	1	KEYSWITCH ASY, KEYSWITCH + WIR

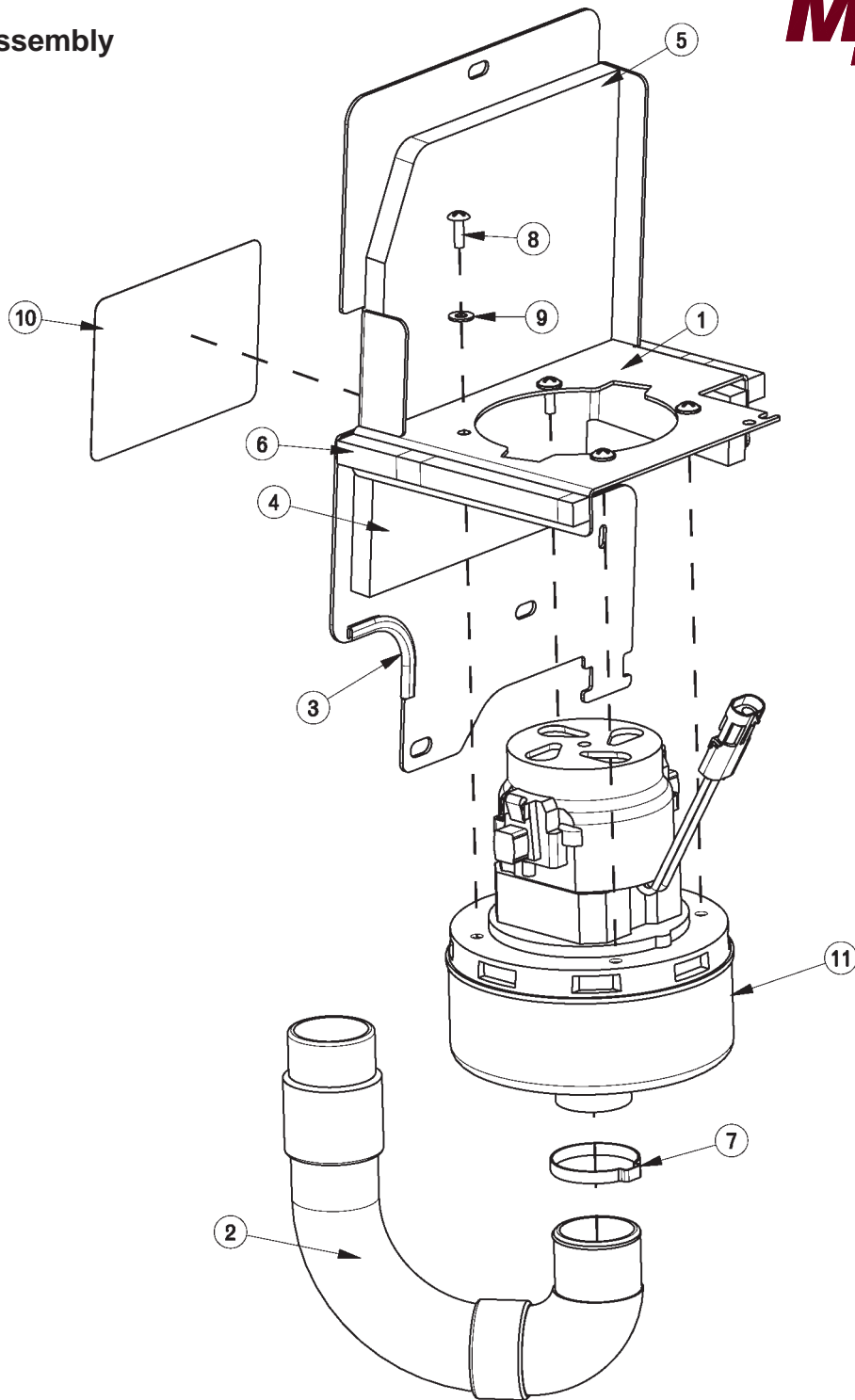

BILL OF MATERIAL - 172050HSP

ITEM	PART NO.	REQ'D	DESCRIPTION	ITEM	PART NO.	REQ'D	DESCRIPTION
1	172045	1	VAC MOUNT WMT, ES1720	7	450095	1	CRIMP CLAMP, 1.75"
2	172048	1	HOSE, STRETCH 13"	8	711160	4	#10 X 5/8 HI-LO
3	172124	1	EDGE TRIM, .063 X 3.0, BLACK	9	711503	4	WSR, FLAT#10
4	172186	1	FOAM COVER, FRONT 1	10	715676	1	DECAL, BATT CABLE ROUTE, E1720
5	172187	1	FOAM COVER, FRONT 2	11	747665-1	1	VAC MOTOR ASY, E1720
6	172188	2	FOAM TAPE, 1/2" SQ X 16.5"				

20" Brush Deck Assembly

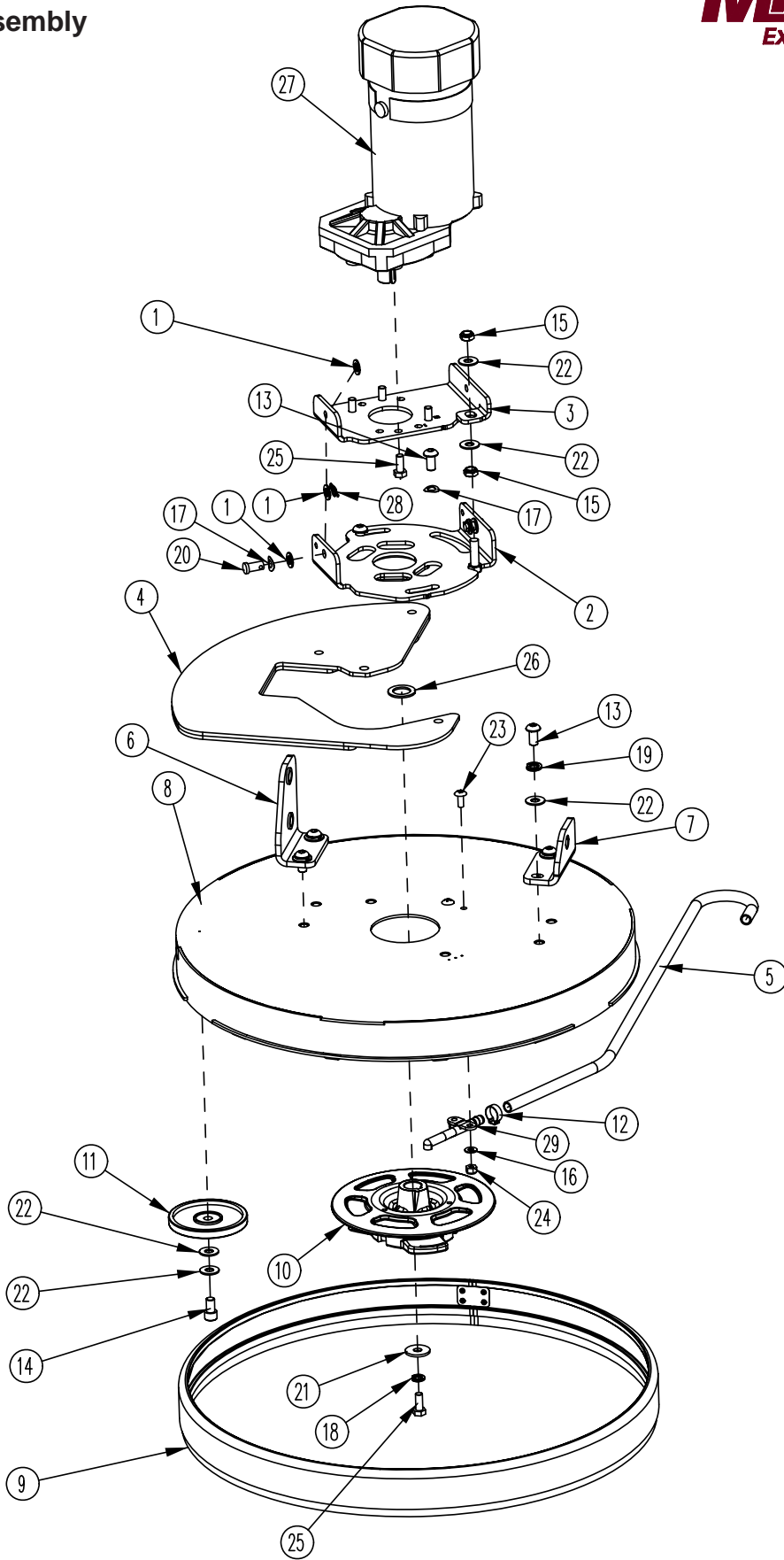

BILL OF MATERIAL - 172100			
ITEM	PART NO.	REQ'D	DESCRIPTION
1	81-166-A	6	SPECIAL WASHER
2	172040	1	DECK ANGLE ADJUST WMT
3	172044	1	PLATE, MOTOR MOUNT
4	172208	1	E20 BRUSH DECK PLATE
5	172216	1	HOSE-WIRE REINF 3/8 X 29"
6	172296	1	BKT, DECK MOUNT RH
7	172297	1	BKT, DECK MOUNT LH
8	172375	1	DECK COVER WMT 20"
9	172384	1	E20 FLOATING BRUSH DECK SKIRT
10	172510	1	HUB ASSEMBLY, DISC DECK
11	210153	1	ROLLER WHEEL
12	450076	1	CLAMP-CRIMP 185R SS
13	710990	6	SCR-SC 3/8-24 X .75 BHEAD ST PL
14	710991	1	SCR-SC 3/8-24 X 5/8 ST PL
15	711375	2	NUT-NYLOC 3/8-16 X 1/2 NUT
16	711504	2	WSR-FLAT 1/4 ID SS
17	711523	4	WSR-WAVE .37X .68 X .08
18	711545	1	WSR-HELICAL 5/16
19	711546	4	WSR-HELICAL 3/8
20	711679	2	CLEVIS PIN 3/8 X 3/4
21	711855	1	WSR-FLT .37X1.12X.10 STL Z HARD
22	712301	8	WSR-FLAT .37 X .87 X .06
23	712565	2	SCR-MC 1/4-20X.63 SS TR HD
24	712667	2	NUT, HEX 1/4-20 NYLOC SS
25	717024	5	BOLT-HH M8X1.25 X 20
26	717025	1	WSR-FLAT 13/16ID X 1.25 X .08
27	747600	1	MOTOR, OFFSET PM GEAR, 550W
28	3400125	2	PIN-COTTER 3/8 RUE RING
29	90311663	1	HAKO SOL FEED NOZZLE

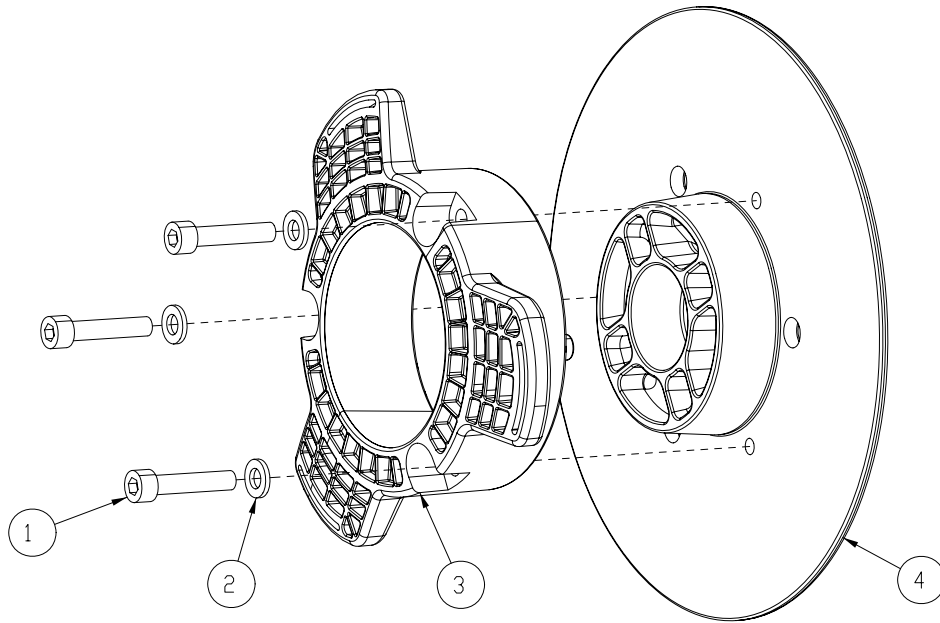

BILL OF MATERIAL - 172510

ITEM	PART NO.	REQ'D	DESCRIPTION
1	11127000	3	SCR-SHCS M6X30 SS, ISO4762
2	12310256	3	WSR-FLT 6.4X12X1.6, SS DIN125
3	90541814	1	DRIVE HUB, PLASTIC 3 LOBE
4	172096MCH	1	BASE, DRIVE HUB WITH KEYWAY

Rear Squeegee Assembly

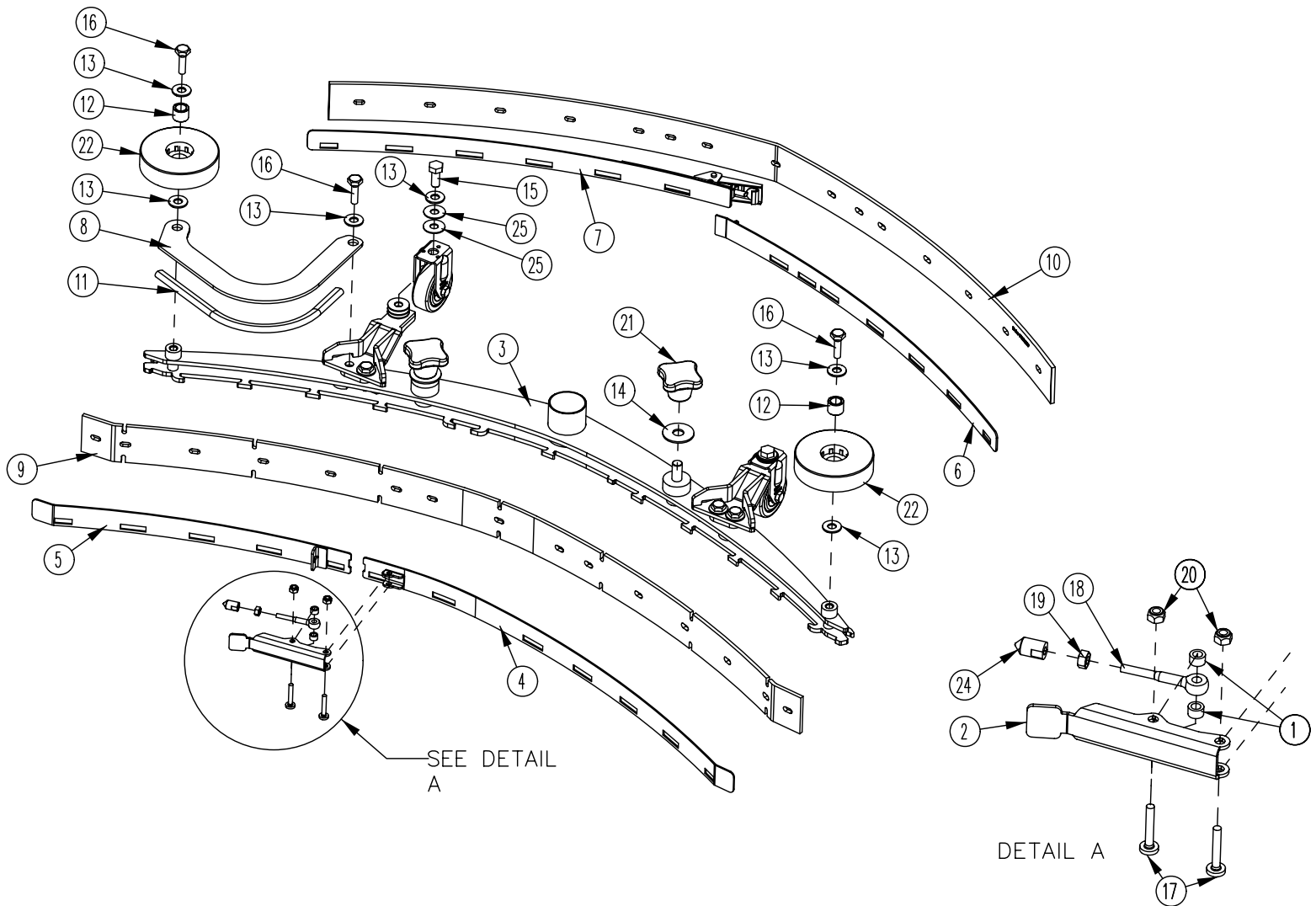

BILL OF MATERIAL - 172270

ITEM	PART NO.	REQ'D	DESCRIPTION	ITEM	PART NO.	REQ'D	DESCRIPTION
1	172074	2	SPACER, 5/16OD X 17GA, ALUM	14	712773	2	WSR FLAT .438 X 1.25 X .07 SS
2	172234	1	LEVER, 90535758	15	717030	2	BOLT-HH M8X1.25 X 20 SS
3	172235	1	SQUEEGEE WMT, 34" (860)	16	11039567	6	BLT-HH M8 X 25 SS DIN933
4	172240	1	STRAP WMT, FRONT LEFT	17	11175494	2	SCR-MC M5 X 25 SS DIN7985
5	172241	1	STRAP WMT, FRONT	18	11518313	1	BLT-EYE M5 X 40 SS
6	172245	1	STRAP WMT, REAR	19	12022430	1	NUT-HEX M5 SS DIN934
7	172246	1	STRAP WMT, REAR	20	12040283	2	NUT-HEX M5 NYLOC SS DIN985
8	172271	1	BUMPER, 34" SQG	21	17133026	2	KNOB, M10 STAR HANDLE
9	172272	1	FRNT SQG BLADE 34", 1/8 PU	22	90336637	2	WHEEL, 3.15OD
10	172273	1	REAR SQG BLADE 34", 1/8 PU	23	90513094	2	FIXED CASTOR
11	172274	1	EDGE TRIM 5/16 X 10" BLACK	24	90513631	1	PIN, THD 90513631
12	430322	2	BUSHING .435 X .625 X .50	25	90531112	10	WSR-FLT 8.3 X 22 X 1MM SS
13	712772	10	WSR-FLAT .344 x .75 x .06 SS	26	96116389	2	SQG CASTER WMT

Squeegee Mechanism Assembly

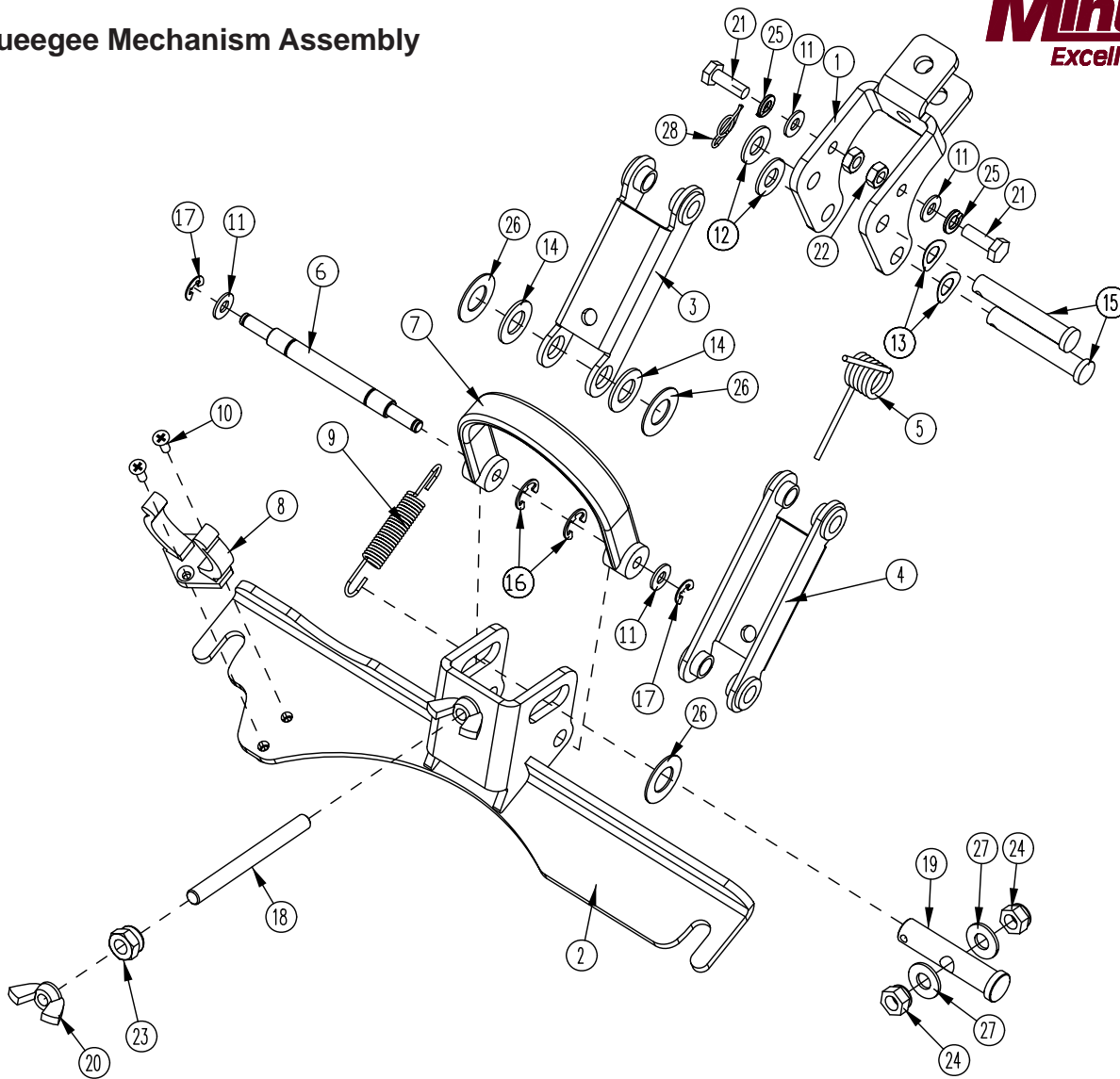

BILL OF MATERIAL - 172150

ITEM	PART NO.	REQ'D	DESCRIPTION	ITEM	PART NO.	REQ'D	DESCRIPTION
1	172134	1	BKT, MAIN SQUEEGEE HINGE	15	711678	2	CLEVIS PIN 3/8 X 2-1/4
2	172155	1	SQUEEGEE MOUNT WMT	16	711717	2	RETAINING RING- E TYPE .37
3	172196	1	SQ TOP LINK W/ BUSHING	17	711720	2	.250 DIA RETAINING RING- E TYPE
4	172197	1	SQ BOT LINK W/ BUSH	18	712147	1	ROD-THD 5/16-18 X 3.5 SS
5	172261	1	TORSION SPRING	19	712148	1	CLEVIS PIN, 1/2 x 2.25 W/ HOLE
6	172352	1	PIN, 3/8 X 3.0, SQG STRAP	20	712157	2	NUT- WING 5/16-18 SS
7	172357	1	STRAP, 9" PU, BLACK	21	712562	2	BOLT-HH 1/4-20X3/4 SS
8	260579	1	TOOL CLIP, 1.5" HOSE	22	712665	2	NUT-HEX 1/4-20 SS
9	430051	1	RETURN SPRING-3.00"	23	712680	1	NUT-HEX 5/16-18 SS
10	710530	2	SCR-MC FL HD 8-32 X .50 BRS	24	712683	2	NUT, HEX 5/16-18 NYLOC SS
11	711504	4	WSR-FLAT 1/4 ID SS	25	712758	2	WSR-HELICAL 1/4 SS
12	711515	2	WSR-FLAT .406 X .812 X .0625	26	712760	3	WSR-FLAT .56X1.06X.04 SS
13	711523	2	WSR-WAVE .37X .68 X .08	27	712772	2	WSR-FLAT .344 x .75 x .06 SS
14	711592	2	WSR-FLAT .506 X .9 X .064 NYL	28	3400125	1	PIN-COTTER 3/8 RUE RING

2

ELECTRICAL BOX ASSEMBLY
172070-120
172070-230

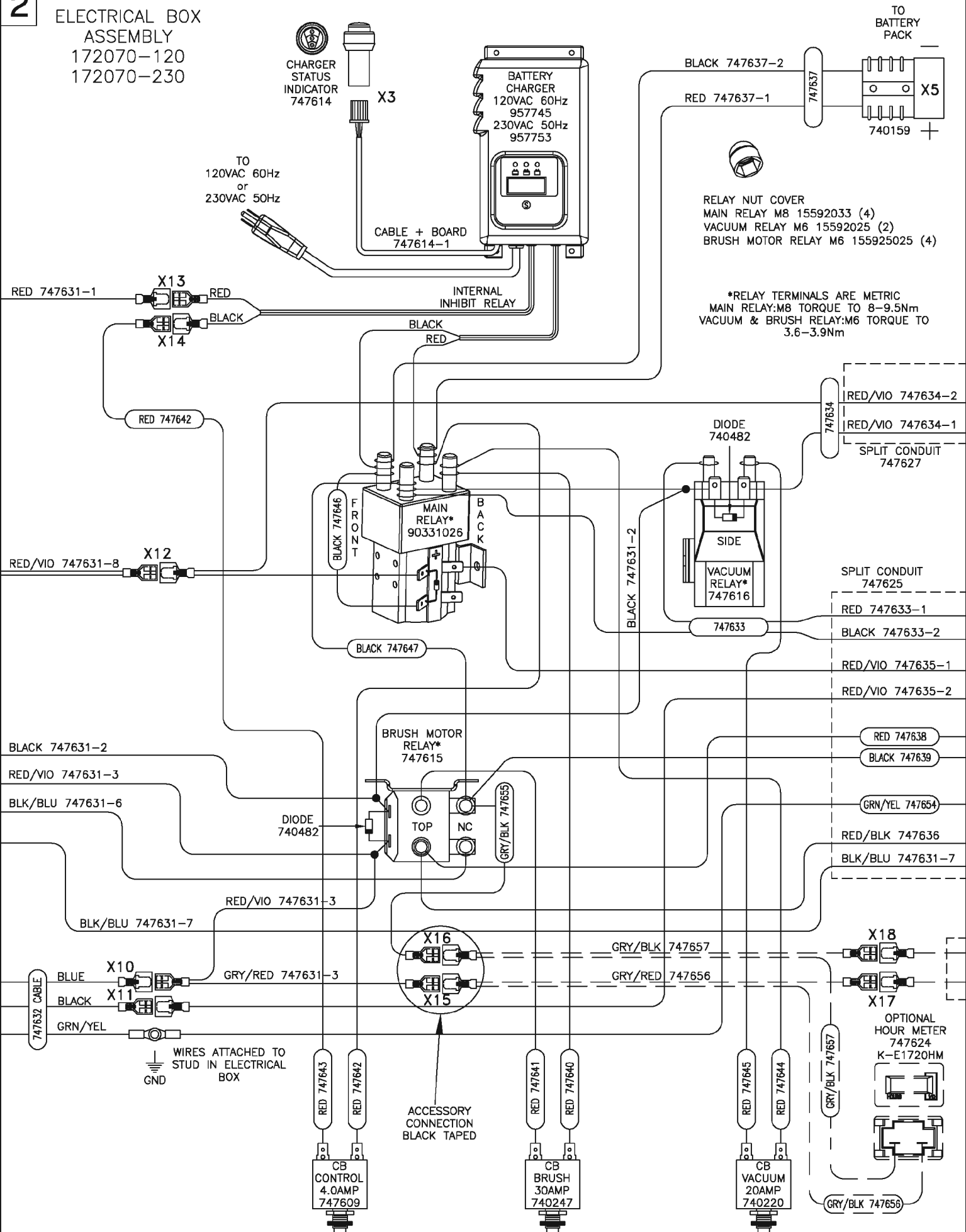

3

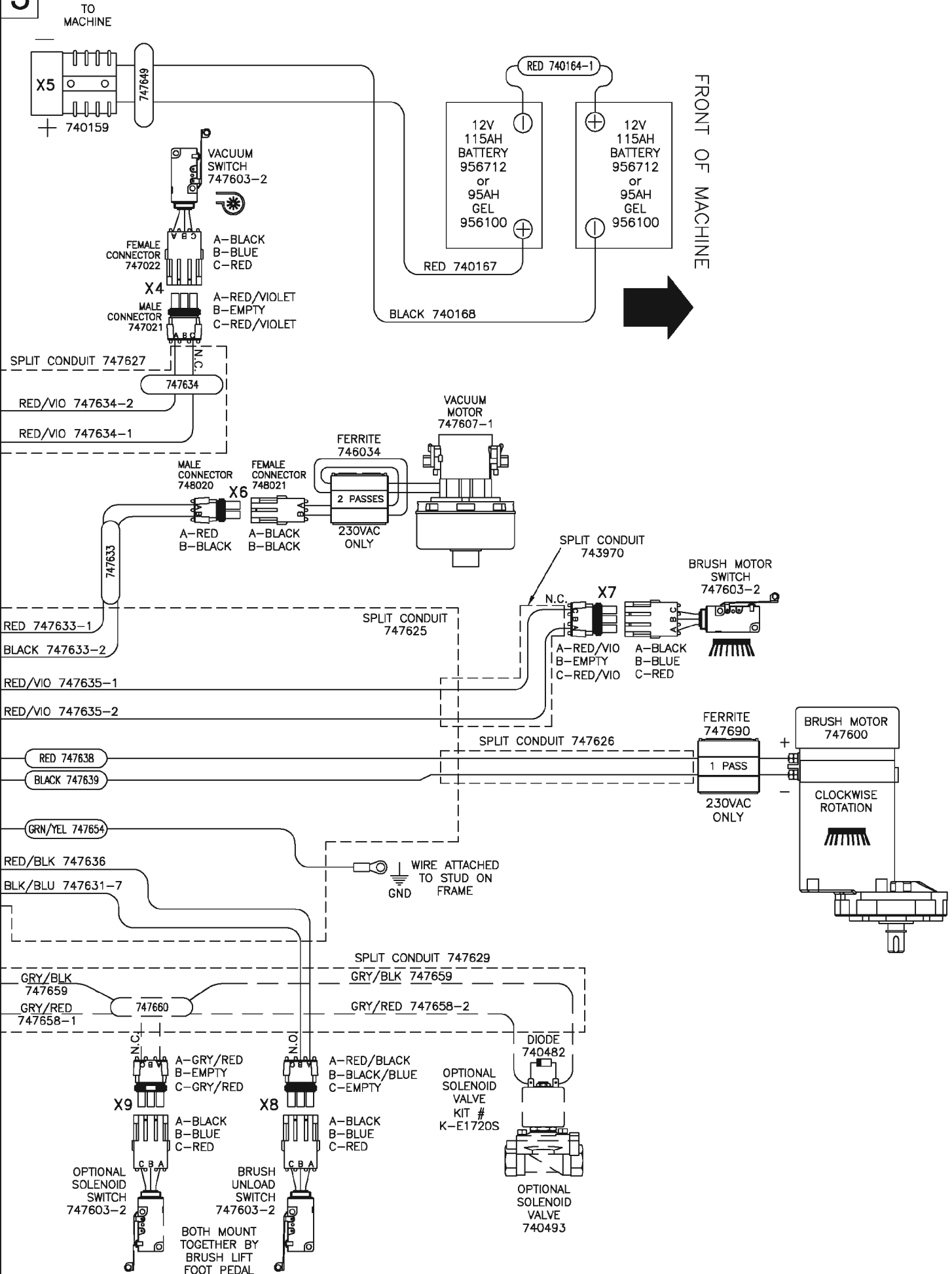

Minuteman International Made Simple Commercial Limited Warranty



REVISION F
EFFECTIVE 6/1/2009

Minuteman International, Inc. warrants to the original purchaser/user that the product is free from defects in workmanship and materials under normal use. Minuteman will, at its option, repair or replace without charge, parts that fail under normal use and service when operated and maintained in accordance with the applicable operation and instruction manuals. All warranty claims must be submitted through and approved by factory authorized repair stations.

This warranty does not apply to normal wear, or to items whose life is dependent on their use and care, such as belts, cords, switches, hoses, rubber parts, electrical motor components or adjustments. Parts manufactured by Minuteman are covered by and subject to the warranties and/or guarantees of their manufacturers. Please contact Minuteman for procedures in warranty claims against these manufacturers.

Special warning to purchaser — Use of replacement filters and/or prefilters not manufactured by Minuteman or its designated licensees, will void all warranties expressed or implied. A potential health hazard exists without original equipment replacement.

All warranted items become the sole property of Minuteman or its original manufacturer, whichever the case may be.

Minuteman disclaims any implied warranty, including the warranty of merchantability and the warranty of fitness for a particular purpose. Minuteman assumes no responsibility for any special, incidental or consequential damages.

This limited warranty is applicable only in the U.S.A. and Canada, and is extended only to the original user/purchaser of this product. Customers outside the U.S.A. and Canada should contact their local distributor for export warranty policies. Minuteman is not responsible for costs or repairs performed by persons other than those specifically authorized by Minuteman. This warranty does not apply to damage from transportation, alterations by unauthorized persons, misuse or abuse of the equipment, use of non-compatible chemicals, or damage to property, or loss of income due to malfunctions of the product.

If a difficulty develops with this machine, you should contact the dealer from whom it was purchased.

This warranty gives you specific legal rights, and you may have other rights which vary from state to state. Some states do not allow the exclusion or limitation of special, incidental or consequential damages, or limitations on how long an implied warranty lasts, so the above exclusions and limitations may not apply to you.

Cord Electric Group: Three years parts, two years labor, ninety days travel (Not to exceed two hours)

Exceptions.....

Model	Parts	Labor	Poly	Travel
Port A Scrub	1yr	6months	10yrs	0
MPV 13	1yr	0	0	0
MPV 14 & 18	2yrs	1yr	0	0
V Series Upright Vacuums	1yr	1yr	0	0
Rapid Air Blower	1yr	1yr	10yrs	0
Explosion Proof Vacuum	1yr	1yr	0	0
X12, X12H & TRS 14	1yr	1yr	10yrs	0
E17 & E20 Electric Scrubbers	1yr	6month	10yrs	0
Pneumatic Vacuums	3yr	1yr	0	0

Description	Parts	Labor	Poly	Travel
Battery Operated Group	3yrs	2yrs	10	90 days
Sweepers	1yr	1yr	10	90 days
Internal Combustion Group	1yr	1yr	10	90 days

Not to exceed two hours

Exception: PAS 14B **1yr** **1yr** **10yr** **0**

Battery Chargers:

Replacement Parts:

Batteries:

Polyethylene Plastic Tanks:

One year replacement

Ninety days

0-3 months replacement, 4-12 months pro-rate

Tanks have 10yr warranty, no additional labor