



Electronic Service Manuals

This electronic document is provided as a service to our customers. We do not create the contents of the information contained in this document. Should you have detailed questions pertaining to the information contained in this document, you may contact Michco, or the manufacturer which provided the original information in this electronic deliverable. Michco's only part in this electronic deliverable was the electronic assembly process. By providing this manual on line we are not guaranteeing parts availability.

You may contact Michco through the following methods:

Phone (517) 484-9312 or (800) 331-3339

2011 N. High St. -- Lansing, Michigan -- 48906

Fax: (517) 484-9836

Email: CustServe@Michco.com

Web site: www.Michco.Com

Parts Web site: www.FloorMachineParts.Com

Order Parts on Line at:

www.FloorMachineParts.Com

Directly to Parts & Service:

By Email: **Shop@Michco.com**

By Fax: (517) 702-2041

By Voice: Use numbers above.

Serving the Cleaning Industry Since 1922

Notice: All copyrighted material remains property of original owners, all trademarks are property of respective owners. Manuals are subject to Manufacturer's reproduction limitations. Originals or reproductions were provided by manufacturers through a request. We make no warranty as to the correctness of information provided in this document and you assume all risk. By placing these manuals on line we are not declaring our corporation to be an manufacturer authorized dealer or provider, please check our web site for authorized manufacturers we represent.

Razor™ 20 / 20T

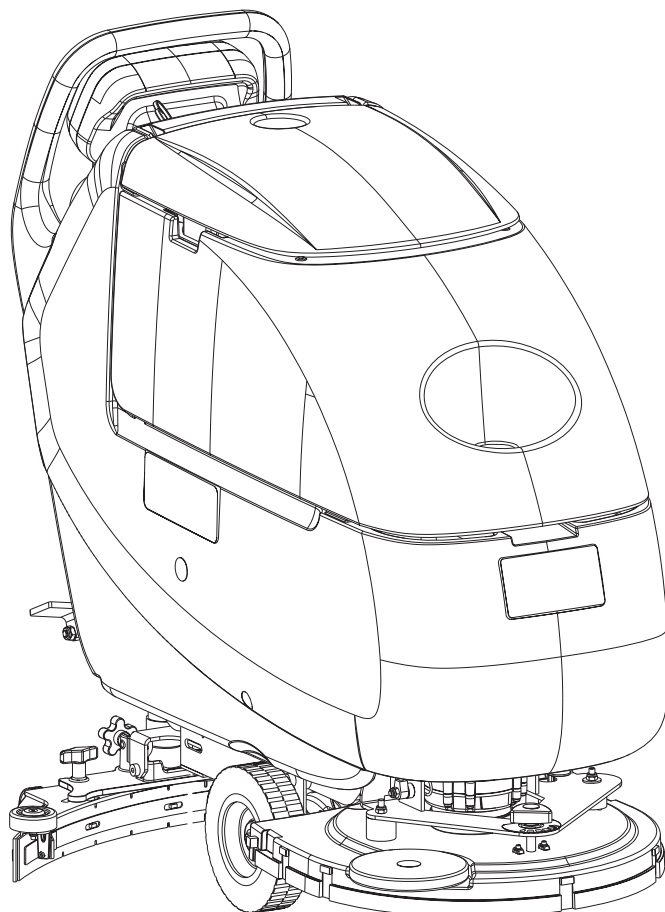

PARTS LIST

Kent models: 9087200020
9087201020

KENT

Simple. Clean.

9097064000(4)2011-11

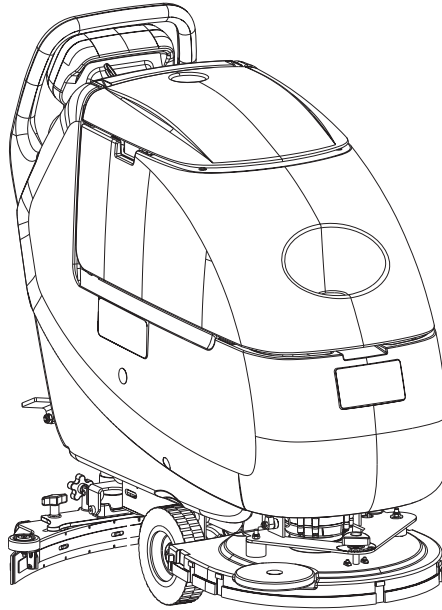

DESCRIPTION

PLAN

GENERAL VIEW	2 - 3
SOLUTION TANK	4 - 5
RECOVERY TANK	6 - 7
CHASSIS SYSTEM	8 - 9
WHEEL SYSTEMS	10 - 11
HANDLE ASSEMBLY	12 - 13
SOLUTION SYSTEM	14 - 15
SQUEEGEE SYSTEM	16 - 17
BRUSH SYSTEM Razor™ 20	18 - 19
BRUSH SYSTEM Razor™ 20T	20 - 21
ACCESSORIES	22 - 23
CONTROL PANEL SYSTEM Razor™ 20	24 - 25
CONTROL PANEL SYSTEM Razor™ 20T	26 - 27
ELECTRICAL COMPONENTS Razor™ 20	28 - 29
ELECTRICAL COMPONENTS Razor™ 20T	30 - 31
WIRING DIAGRAMS	32 - 33
RECOMMENDED SPARE PARTS	34 - 35

WHEN ORDERING PARTS

- * Use the 8, 9 or 10 digit numbers from the "Ref. No." columns in this parts list.
- * Specify the model and serial number of the machine.
- * Use the space below to record the model and serial number for future reference.

Model _____ Serial No. _____

*** = Optional**

= Modified item No. or New item No.

[] = Not shown

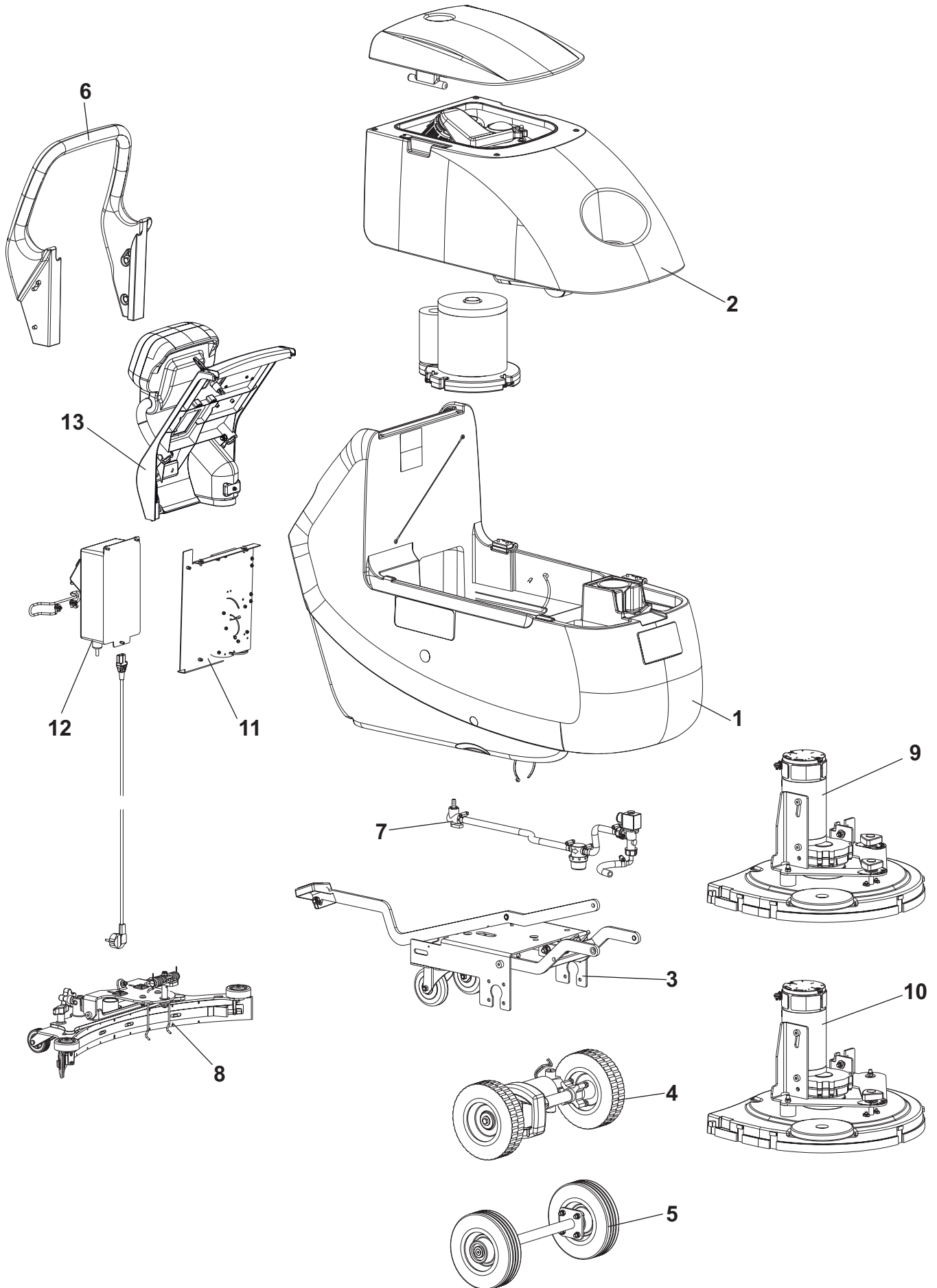

2007-06	GENERAL VIEW			
2009-06	Razor™ 20 - 20T			3

Item No.	Ref. No.	Qty	Description
1		1	SOLUTION TANK
2		1	RECOVERY TANK
3		1	CHASSIS SYSTEM
4		1	WHEELS TRACTION SYSTEM
5		1	WHEELS SYSTEM
6		1	HANDLE SYSTEM
7		1	SOLUTION SYSTEM
8		1	SQUEEGEE SYSTEM
9		1	BRUSH SYSTEM Razor™ 20
10		1	BRUSH SYSTEM Razor™ 20T
11		1	ELECTRICAL COMPONENTS
12		1	BATTERY CHARGER ASSEMBLY
13		1	CONTROL PANEL SYSTEM

2007-06	SOLUTION TANK			
2011-11	Razor™ 20 - 20T			5

Item No.	Ref. No.	Qty	Description
1	9098265000	1	SOLUTION TANK HARDWARE KIT
2	145 8479 000	1	DOWEL M6
3	909 6493 000	1	PEDAL SUPPORT
4	9098350000	1	DECALS KIT
5	909 6596 000	1	GASKET
6	909 6597 000	1	GASKET
7	909 6892 000	2	GASKET
8	9097630000	1	HARDWARE SQUEEGEE LEVER FIXING KIT
9	909 6874 000	1	CABLE TANK BLOCK KIT
10#	9098936000	1	BRACKET CONNECTOR SUPPORT
11#	9098033000	1	GASKET HANDLE BAR
12#	9098673000	1	SQUEEGEE LIFTING CABLE KIT - TSB IT 2010-053
	9098861000	1	INSTALLATION INSTRUCCIONES
13	909 6673 000	1	CAP
15	9097296000	1	FRESH WATER HOSE
19	9097019000	1	HANDLE BAR
20	L08812457	2	TANK LOCKING CAP
21#	9099374000	1	FITTING PIPE
37	909 6236 000	1	BLACK CAP
38	9097020000	1	SOLUTION TANK 35 LT
48	9097192000	1	FILTER WATER INLET
49	9098329000	1	HINGES KIT
50	33005445	4	SCRE HEX HD M8X25
51	L08300000	6	WASHER FLAT XL
52	145 8412 000	2	SCREW GRUB M8X30 UNI5929
53	146 1567 000	2	NUT HEX M8

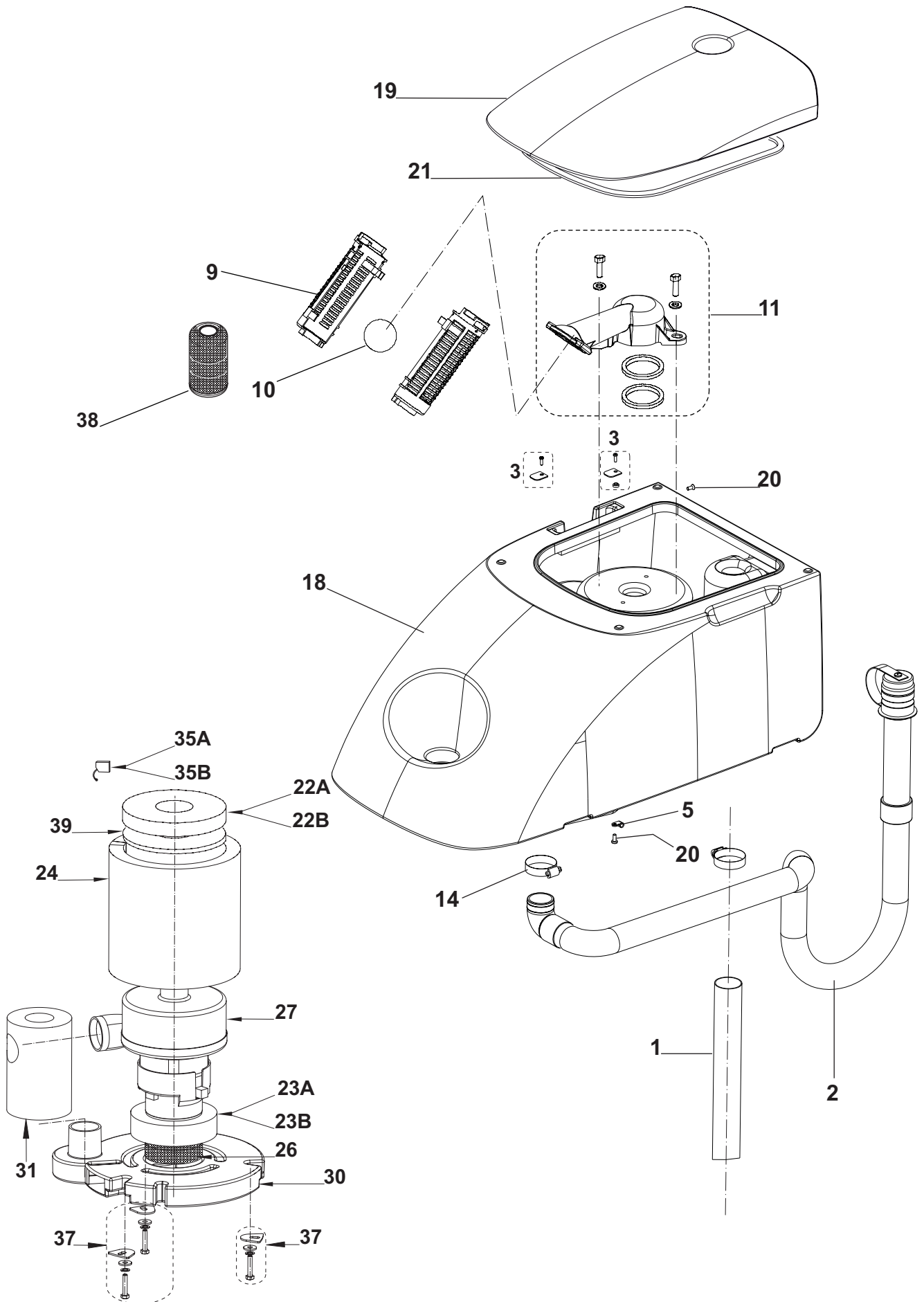

2007-06	RECOVERY TANK			
2011-11	Razor™ 20 - 20T			7

Item No.	Ref. No.	Qty	Description
1	909 6230 000	1	VACUUM HOSE
2#	9099166000	1	DRAIN HOSE
3	9097654000	1	TANK FIXING KIT
5	L08239900	1	CLAMP
9	L08812259	2	CAGE FLOAT COMPLETE
10	L08812373	1	FLOATING BALL
11	9097726000	1	CAGE FLOAT HOLDER KIT
	9097727000	1	INSTALLATION INSTRUCTIONS FOR CAGE FLOAT HOLDER KIT
14	145 0543 000	2	CLAMP
18	9097016000	1	RECOVERY TANK 35L
19	9097017000	1	TANK COVER 35L
20	33005124	2	SCREW M5X12 UNI7688
21	909 6268 000	1	COVER TANK GASKET
22A	9096918000	1	GASKET SUCTION MOTOR
22B	9098057000	1	GASKET SUCTION MOTOR
23A	909 6490 000	1	GASKET SUCTION MOTOR
23B	9098056000	1	GASKET SUCTION MOTOR
24	909 6491 000	1	ACOUSTIC INSULATION PANEL
26	909 6672 000	1	FILTER
27#	9099401000	1	MOTOR VACUUM KIT
30	909 6051 000	1	VACUUM MOTOR COVER
31	909 6442 000	1	ACOUSTIC INSULATION PIPE
35A	909 5371 000	2	CARBON BRUSH (AMETEK)
35B	9098231000	1	CARBON BRUSH KIT (VIPER)
37	909 6877 000	1	VACUUM MOTOR HARDWARE KIT
38*	909 5065 000	1	FILTER ANTIFOAMING - TSB IT 2008-002
39	9097169000	1	GASKET VACUUM MOTOR
[40]	909 6876 000	1	HARDWARE OLD TYPE CAGE SUP.FIXING KIT
[41]*#	9098854000	1	ELBOW 90. SUCT. HOSE KIT BLACK

A: FOR MOTOR 9099401000 (AMETEK)

B: FOR MOTOR 9098062000 (VIPER)

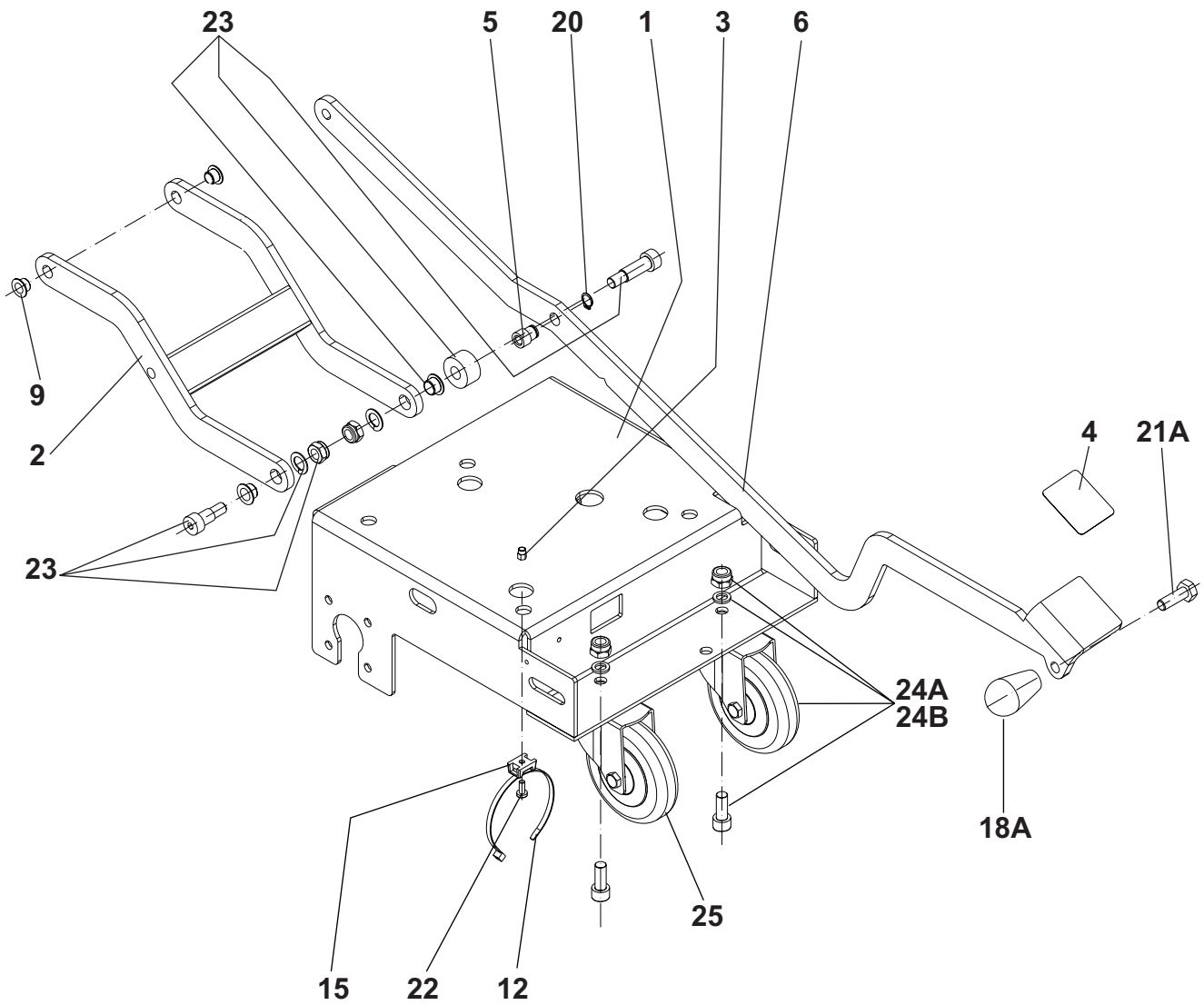
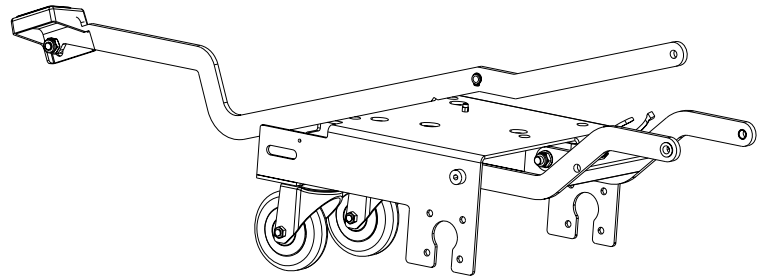

2007-06	CHASSIS SYSTEM			
2011-11	Razor™ 20 - 20T			9

Item No.	Ref. No.	Qty	Description
1	909 6482 000	1	CHASSIS
2	909 6486 000	1	LEVER BRUSH LIFTING
3	145 6132 000	1	INSERT M5
4	909 6539 000	1	ANTISKID MAT
5	909 6540 000	1	BUSHING FLANGED
6	9097024000	1	PEDAL BRUSH LIFTING
9	909 6594 000	3	BUSHING FLANGED
12	145 0524 000	3	PASSRING
15	909 6595 000	1	FLAT TIE HOLDER
18A	909 6621 000	1	KNOB
20	33006051	1	RETAINING RING
21A	33004010	1	SCREW HEX HD M10X30
22	909 6337 000	1	SCREW CYL HD M5X12
23	909 6878 000	1	CHASSIS SYSTEM HARDWARE KIT
24#	9099028000	2	WHEEL CASTOR WITH HARDWARE KIT - TSB IT 2011-071
	9099245000	1	INSTALLATION INSTRUCTIONS
25#	9099014000	2	WHEEL CASTOR CHROMATE

A: FOR SCRUBBER WITH DRIVE

WITHOUT TRACTION
(Razor™ 20)

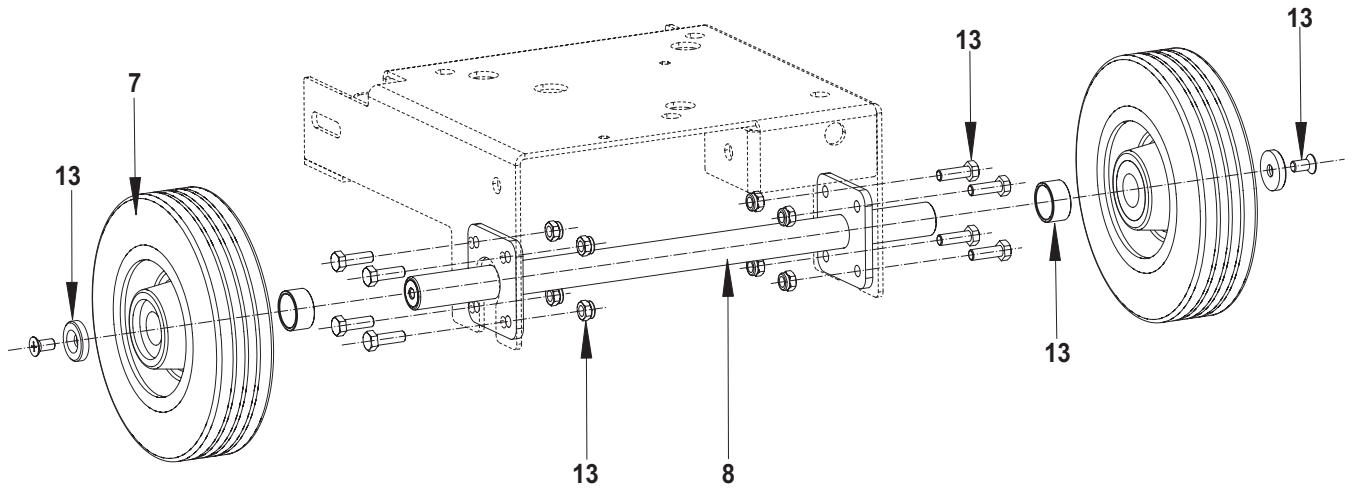

WITH TRACTION
(Razor™ 20T)

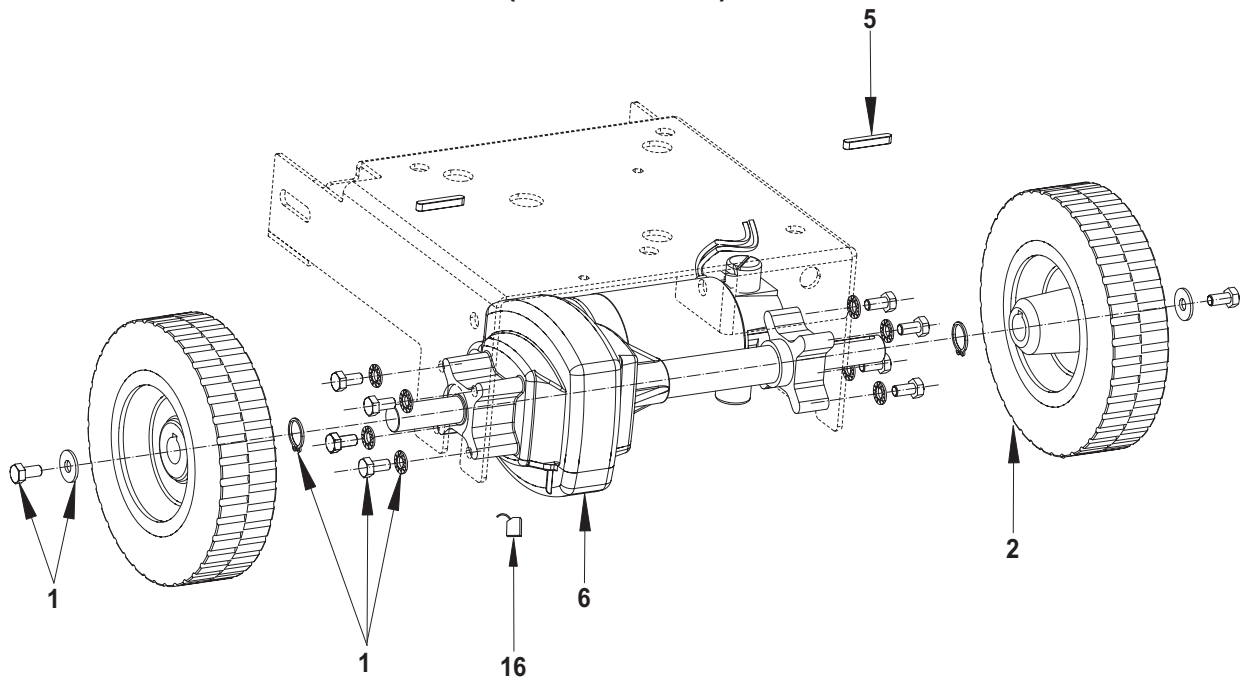

2007-06	WHEEL SYSTEMS		
2011-11	Razor™ 20 - 20T		11

Item No.	Ref. No.	Qty	Description
1	9098298000	1	HARDWARE DRIVE WHEELS KIT
2#	9099204000	2	WHEEL FRONT DRIVE
2*	9097032000	2	WHEEL FRONT DRIVE D.200 65SH
5	146 0769 000	2	KEY
6	909 6548 000	1	MOTODIFFERENTIAL
7	909 6507 000	2	WHEEL
7*	9097167000	2	WHEEL FRONT D.200 65SH
8	909 6508 000	1	WHEELS SHAFT
13	9098299000	1	HARDWARE WHEELS KIT
16	145 5124 000	2	CARBON BRUSH

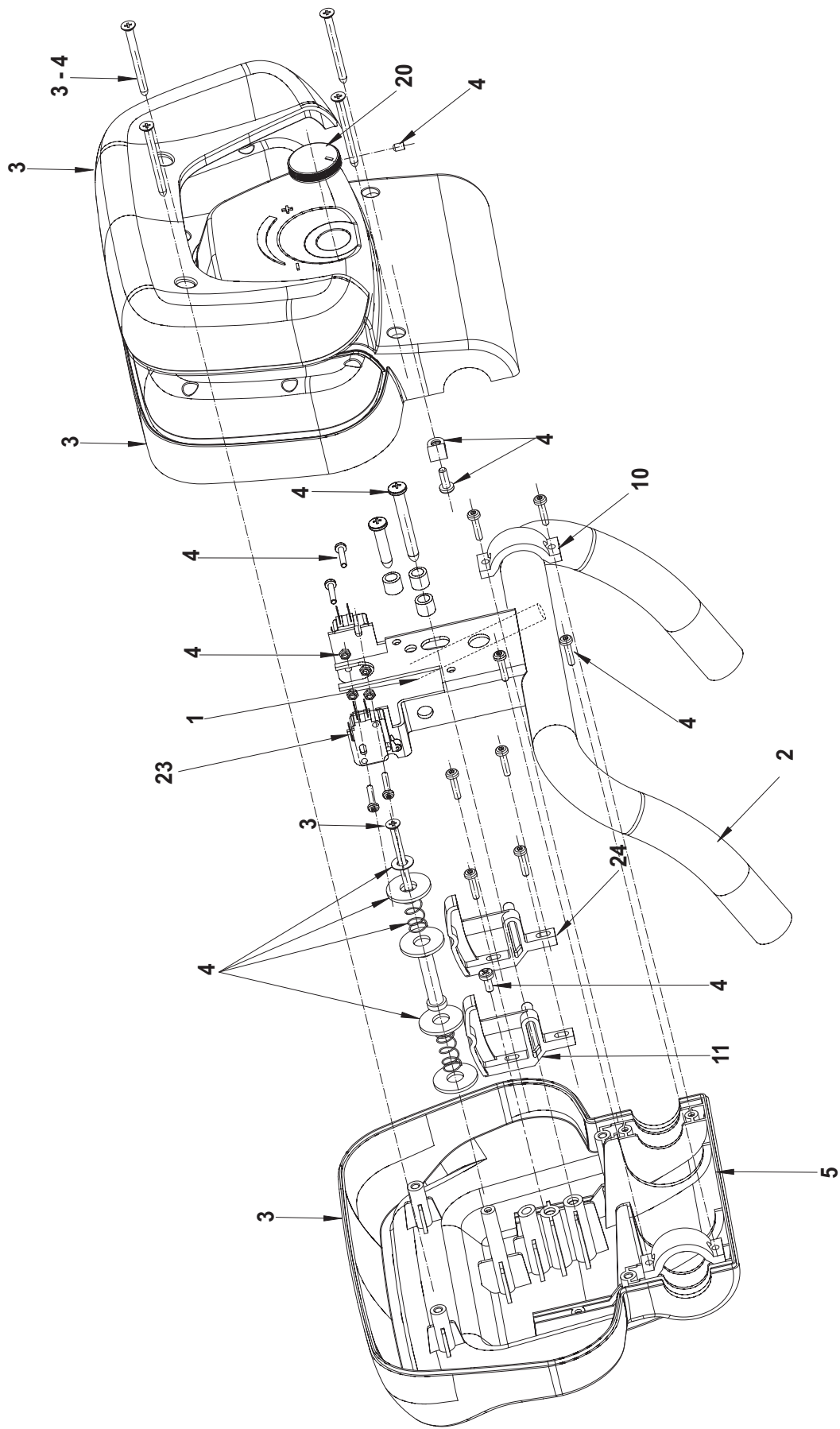

2007-06	HANDLE ASSEMBLY			
2011-11	Razor™ 20T			13

Item No.	Ref. No.	Qty	Description
1	9096907000	1	HANDLE HARNESS
2	909 6653 000	1	HANDLE BAR
3	9097622000	1	SWITCH HOUSINGS UPPER/LOWER KIT
4	9098300000	1	HARDWARE HANDLE AS. KIT
5A#	9098792000	1	HOUSING SWITCH LOWER KIT
10	L08812279	2	CLAMP
11	L08812282	2	MICRO SWITCH CAM
20	909 6471 000	1	POTENTIOMETRE KNOB
23	909 6677 000	1	MICROSWITCH
24	9096923000	1	CAM MICROSWITCH HANDLE
[25]	909 6544 000	1	POTENTIOMETER HARNESS

A: TSB IT 2010-060

INTO THE TANK

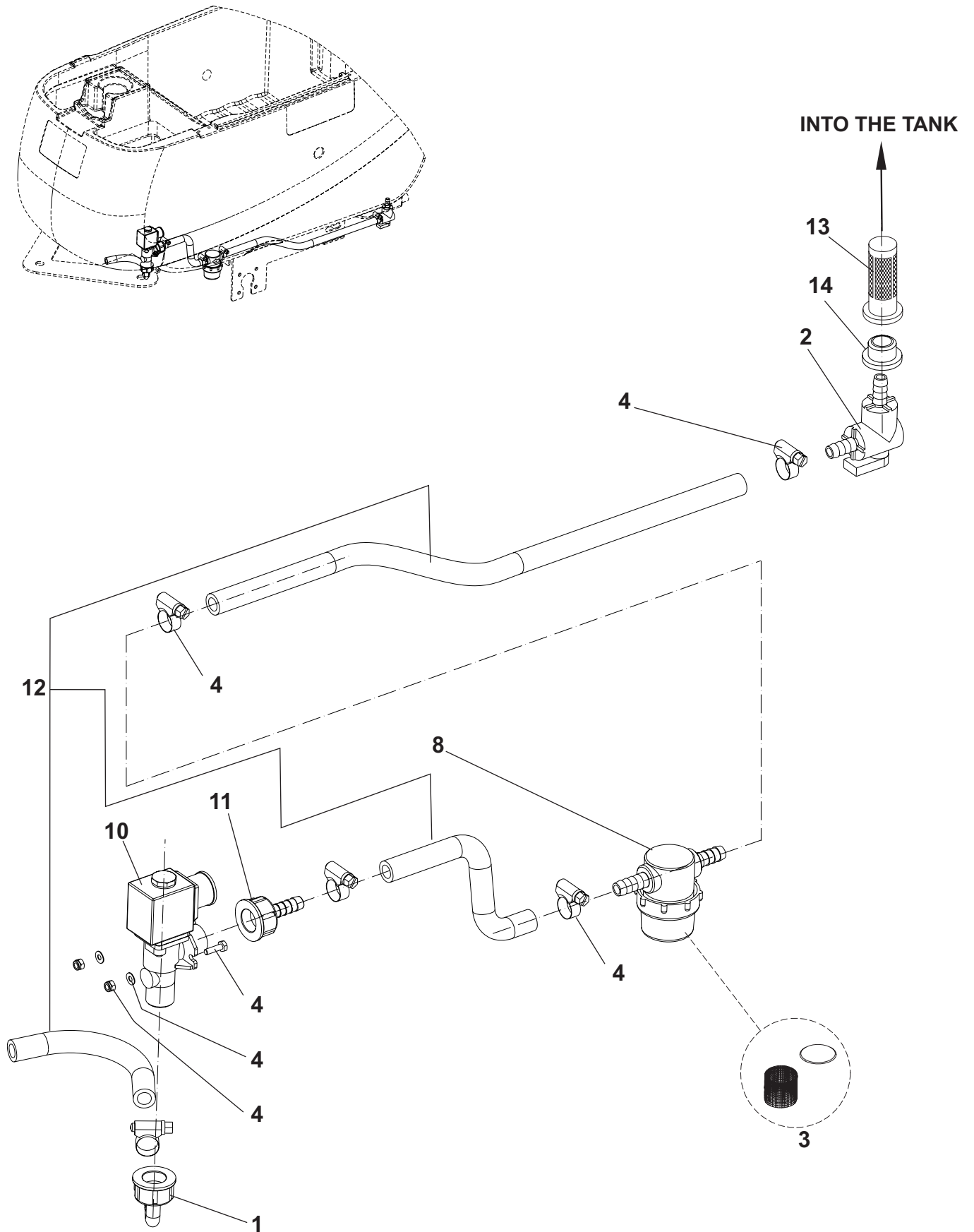

2007-06	SOLUTION SYSTEM			
2009-06	Razor™ 20 - 20T			15

Item No.	Ref. No.	Qty	Description
1	909 6637 000	1	RUBBER HOLDER
2	9096994000	1	VALVE 3/8 PVC F
3	L08603893	1	KIT NET FILTER WITH GASKET
4	9098301000	1	HARDWARE SOLUTION SYSTEM KIT
8	9097166000	1	FILTER KIT CPL
10	909 6555 000	1	SOLENOID VALVE 24V
11	909 6636 000	1	HOLDER RUBBER 1/2 FEMALE
12	9097170000	1	VALVE ELBOW W/PIPES KIT
13*	9096916000	1	FILTER
14	909 5286 000	1	GASKET

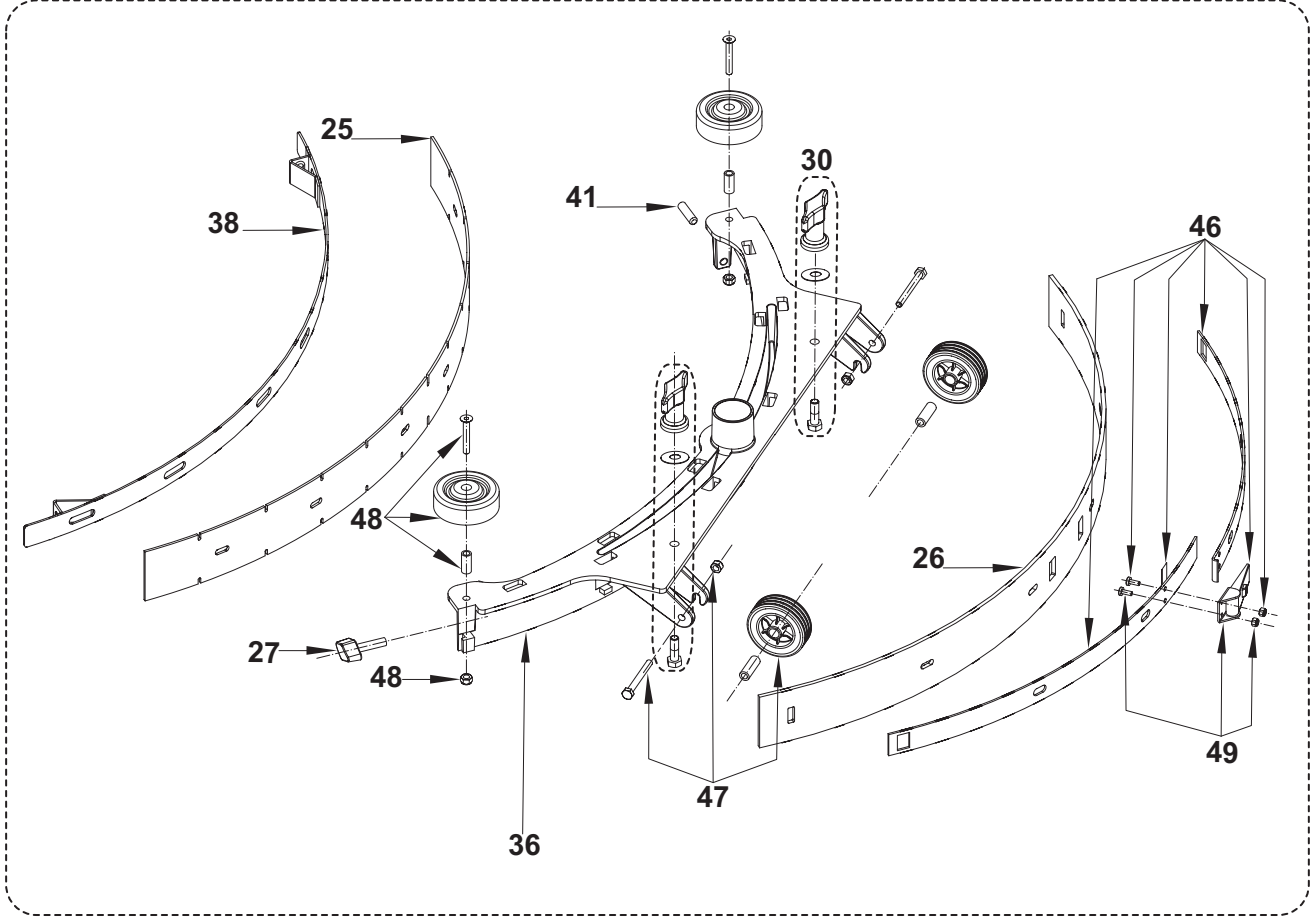
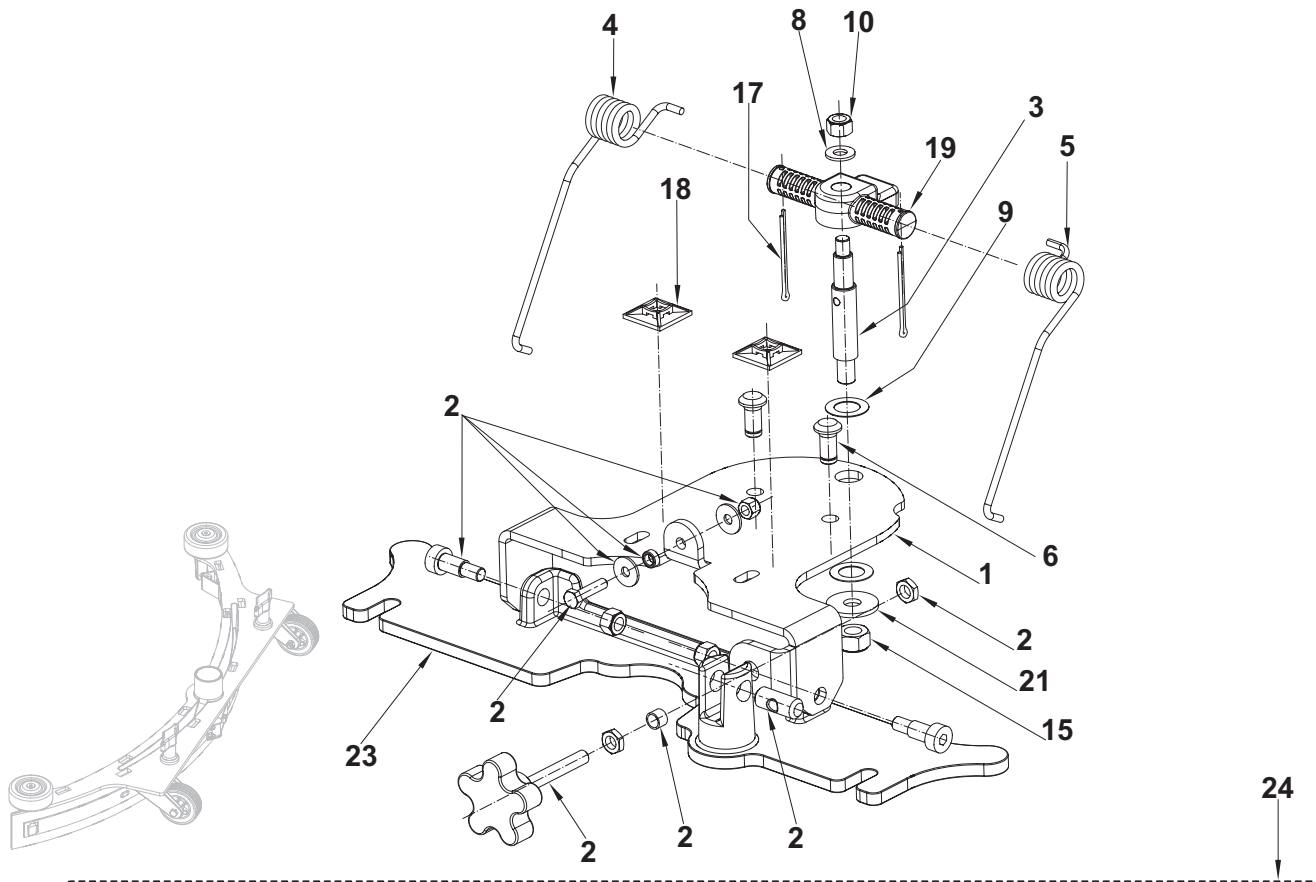

2007-06	SQUEEGEE SYSTEM		
2009-06	Razor™ 20 - 20T		17

Item No.	Ref. No.	Qty	Description
1	909 6494 000	1	SQUEEGEE BRACKET
2	909 6885 000	1	HARDWARE SQUEEGEE FIXING KIT
3	909 6497 000	1	PIN
4	909 6537 000	1	RIGHT SPRING
5	909 6538 000	1	LEFT SPRING
6	909 6543 000	2	PIN
8	33005915	1	WASHER FLAT 8X17
9	L08238300	2	WASHER
10	33005607	3	NUT SELFLOCKING M8
15	33005608	1	NUT
17	33005758	2	SPLIT PIN
18	909 6635 000	2	SELF-ADHESIVE TIE MOUNT
19	909 6052 000	1	SPRING SUPPORT
21	L08604251	1	WASHER FLAT 10X30
23	909 6045 000	1	SQUEEGEE SUPPORT
24	909 6851 000	1	SQUEEGEE CPL ALU KIT 30"
25	909 6483 000	1	BLADE SQUEEGEE FRONT
26	909 6484 000	1	BLADE SQUEEGEE REAR
27	909 6551 000	1	WING NUT M8X30 SS
30	9097637000	1	SQUEEGEE FIXING KIT
36	909 6044 000	1	SQUEEGEE
38	909 6055 000	1	STRAP, SQUEEGEE FRONT
41	909 6600 000	1	DOWEL M8X30 SS
46	909 6882 000	1	FIXING SQUEEGEE KIT
47	909 6883 000	2	KIT SQUEEGEE WHEEL
48	909 6884 000	2	KIT SQUEEGEE BUMPER ROLLER
49	909 6394 000	1	KIT LATCH FOR SQUEEGEE
[50]	909 6860 000	1	BLADES SQUEEGEE 740MM/29" KIT (25-26)
[51]	9097548000	1	WASHERS NYLON SQUEEGEE SUPPORT KIT - TSB IT 2007-031

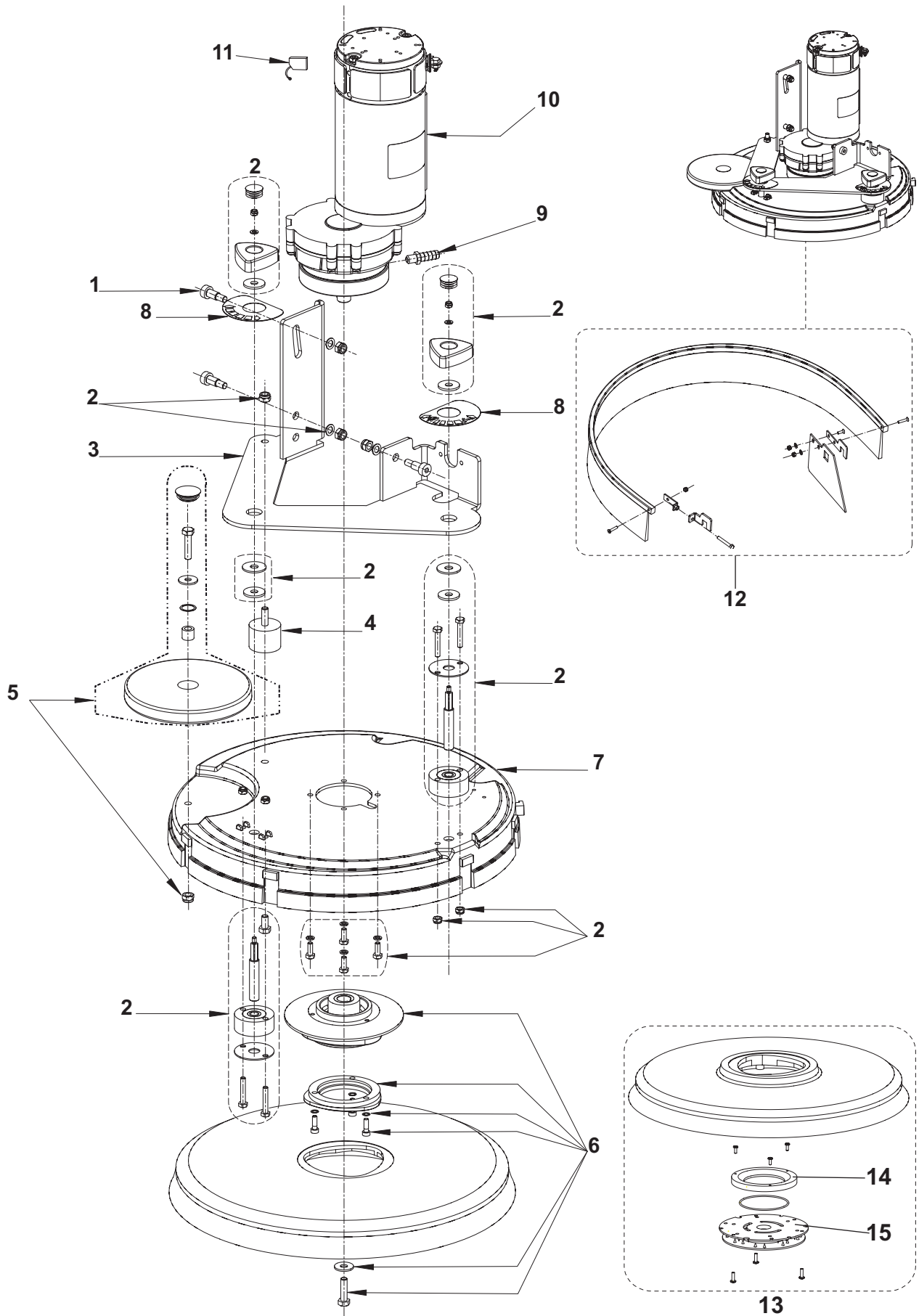

2007-06	BRUSH SYSTEM			
2011-11	Razor™ 20			19

Item No.	Ref. No.	Qty	Description
1	909 6495 000	3	SHOULDER BOLT M10X16
2#	9099419000	1	BRUSH SYSTEM HARDWARE KIT
3	909 6485 000	1	PLATE, DECK BRUSH HOLDER
4	9097184000	1	VIBRATION DAMPING M8
5	909 6887 000	1	BUMPER ROLLER KIT
6	9097093000	1	HOLDERPOLYG.W/FLAGE KIT
7	909 6042 000	1	BRUSH DECK 530MM/20"
8	9098350000	1	DECALS KIT
9	L08601624	1	PIPE HOLDER
10#	9098308000	1	REDUCTION GEARMOTOR CPL.
11#	9098376000	1	CARBON BRUSH (4 PCS) FOR 9098308000 (AMER)
11	909 5380 000	1	CARBON BRUSH (4 PCS) FOR 909 6546 000 (LEROY SOMER)
12	909 6736 000	1	SPLASH GUARD KIT
13	L08837018	1	PAD HOLDER
14	L08603966	1	RING NYLON
15	L08837030	1	RETAINER PAD
	909 6745 000		INSTALLATION INSTRUCTION FOR SPLASH GUARD KIT
[17]*	9097599000	1	PROTECTION MOTOR KIT TSB IT 2008-014
	9097600000	1	INSTRUCTIONS INSTALLATION PROT.MOT.KIT

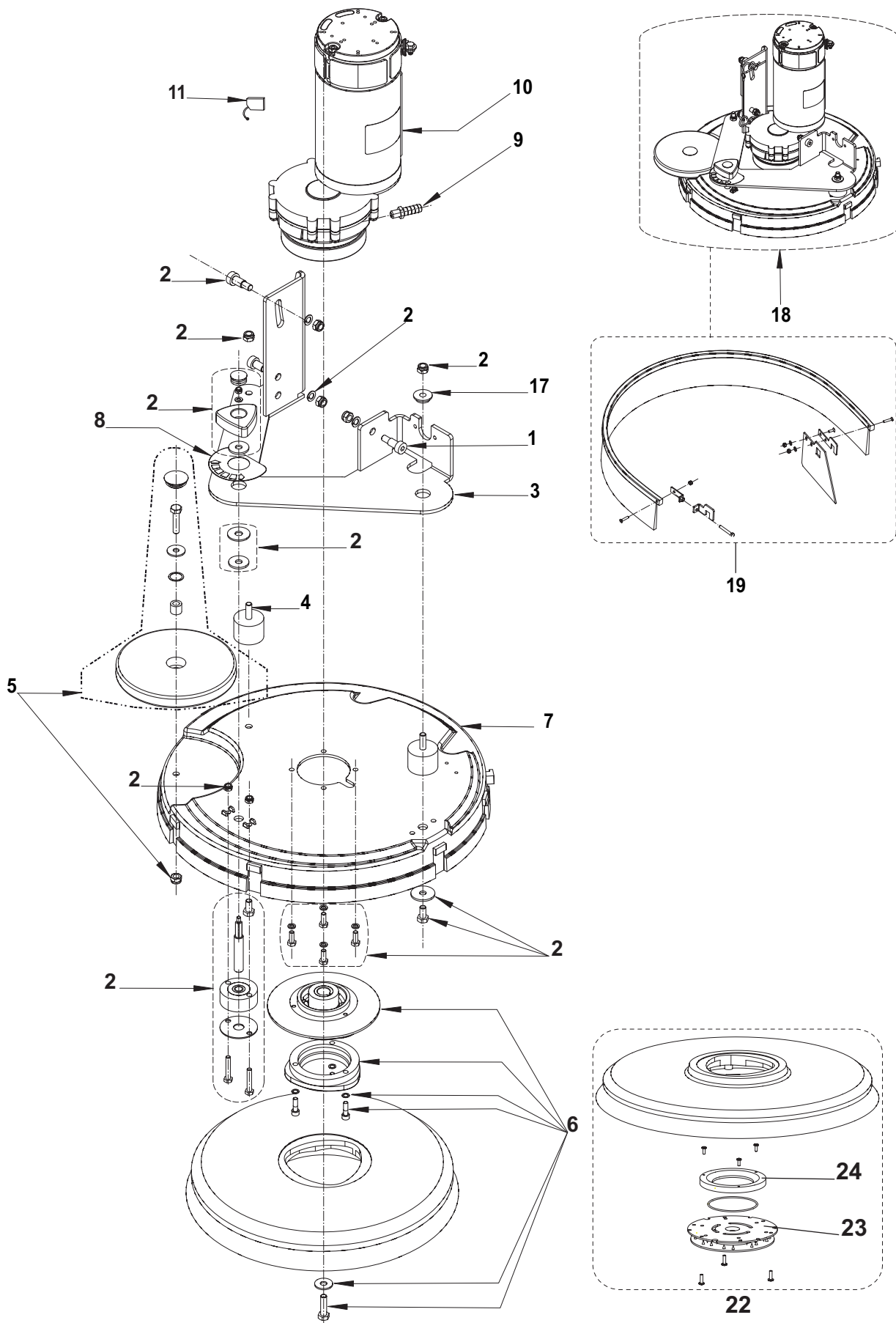

2007-06	BRUSH SYSTEM			
2011-11	Razor™ 20T			21

Item No.	Ref. No.	Qty	Description
1	909 6495 000	2	SHOULDER BOLT M10X16
2	9098344000	1	BRUSH SYSTEM HARDWARE KIT
3	909 6485 000	1	PLATE, DECK BRUSH OLDER
4	9097184000	1	VIBRATION DAMPING M8
5	909 6887 000	1	BUMPER ROLLER KIT
6	9097093000	1	HOLDERPOLYG.W/FLAGE KIT
7	909 6042 000	1	BRUSH DECK 530MM/20"
8	9098350000	1	DECALS KIT
9	L08601624	1	PIPE HOLDER
10#	9098308000	1	REDUCTION GEARMOTOR CPL.
11#	9098376000	1	CARBON BRUSH (4 PCS) FOR 9098308000 (AMER)
11	909 5380 000	1	CARBON BRUSH (4 PCS) FOR 909 6546 000 (LEROY SOMER)
17	909 6513 000	1	BUSHING
18	909 6853 000	1	BRUSH DECK 530MM/21
19	909 6736 000	1	SPLASH GUARD KIT
	909 6745 000		INSTALLATION INSTRUCTION FOR SPLASH GUARD KIT
[20]*	9097599000	1	PROTECTION MOTOR KIT TSB IT 2008-014
	9097600000	1	INSTRUCTIONS INSTALLATION PROT.MOT.KIT
22	L08837018	1	PAD HOLDER
23	L08837030	1	RETAINER PAD
24	L08603966	1	RING NYLON

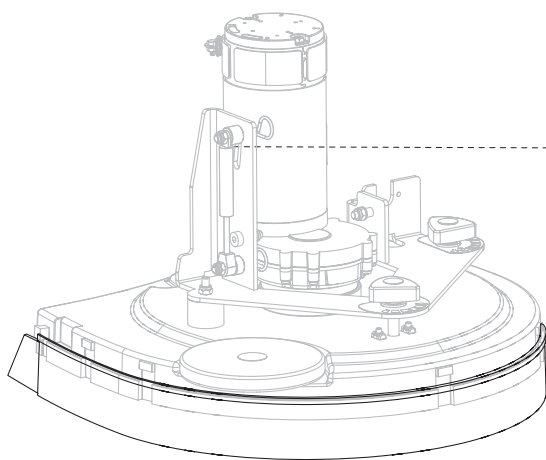
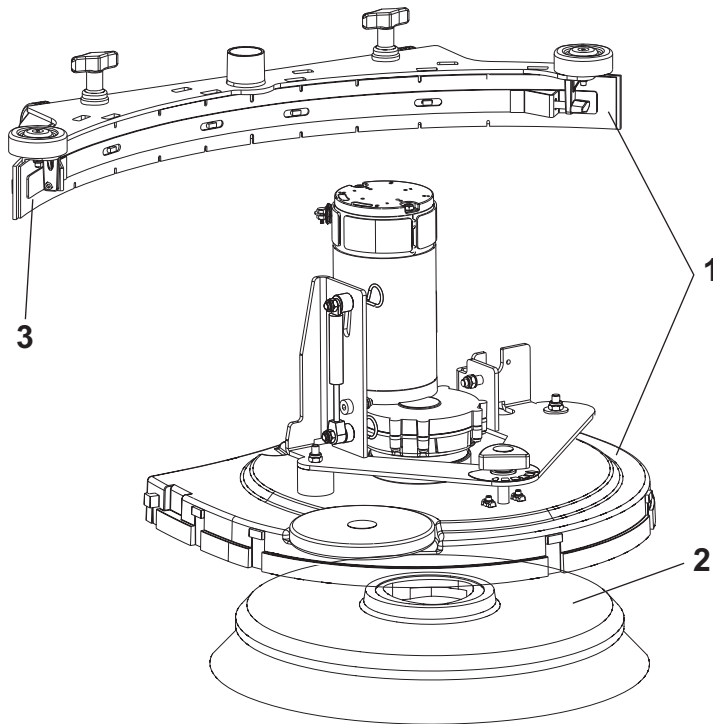

8

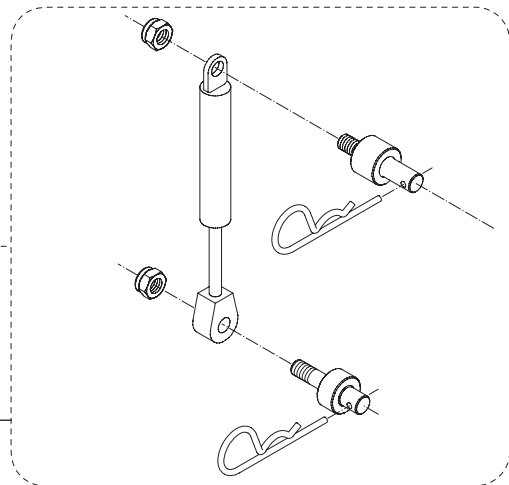

EXTRA PRESSURE KIT

2007-06	ACCESSORIES			
2009-06	Razor™ 20 - 20T			23

Item No.	Ref. No.	Qty	Description
			Razor™ 20T
1*	909 6848 000	1	DISC SCRUB DECK KIT COMPLETE WITH SQUEEGEE
			Razor™ 20 - Razor™ 20T
2*	L08837025	1	BRUSH PROLENE 530MM
2*	L08837026	1	BRUSH PROLITE 530MM
2*	L08837027	1	BRUSH UNION MIX 530MM
2*	L08837028	1	BRUSH MIDLITE GRIT 530MM
2*	L08837029	1	BRUSH MID GRIT 240 530MM
2*	L08837065	1	BRUSH MAGNA GRIT 46 530MM
2*	L08837066	1	BRUSH DYNA GRIT 80 530MM
2*	L08837067	1	BRUSH AGLITE GRIT 500 530MM
			Razor™ 20 - Razor™ 20T
3*	L08603878	1	SQUEEGEE KIT
3	909 6851 000	1	SQUEEGEE KIT ALUMINIUM
			SQUEEGEE BLADES
[4]	909 6483 000	1	BLADE NEOPRENE FRONT
[5]	909 6484 000	1	BLADE NEOPRENE REAR
[6]*	909 6860 000	1	BLADES NEOPRENE KIT 30"
[7]*	909 6858 000	1	BLADES POLYURET. KIT 30"
			Razor™ 20
8*	9097185000	1	EXTRA PRESSURE KIT
	909 6759 000	1	INSTALLATION INSTRUCTIONS FOR EXTRA PRESSURE KIT

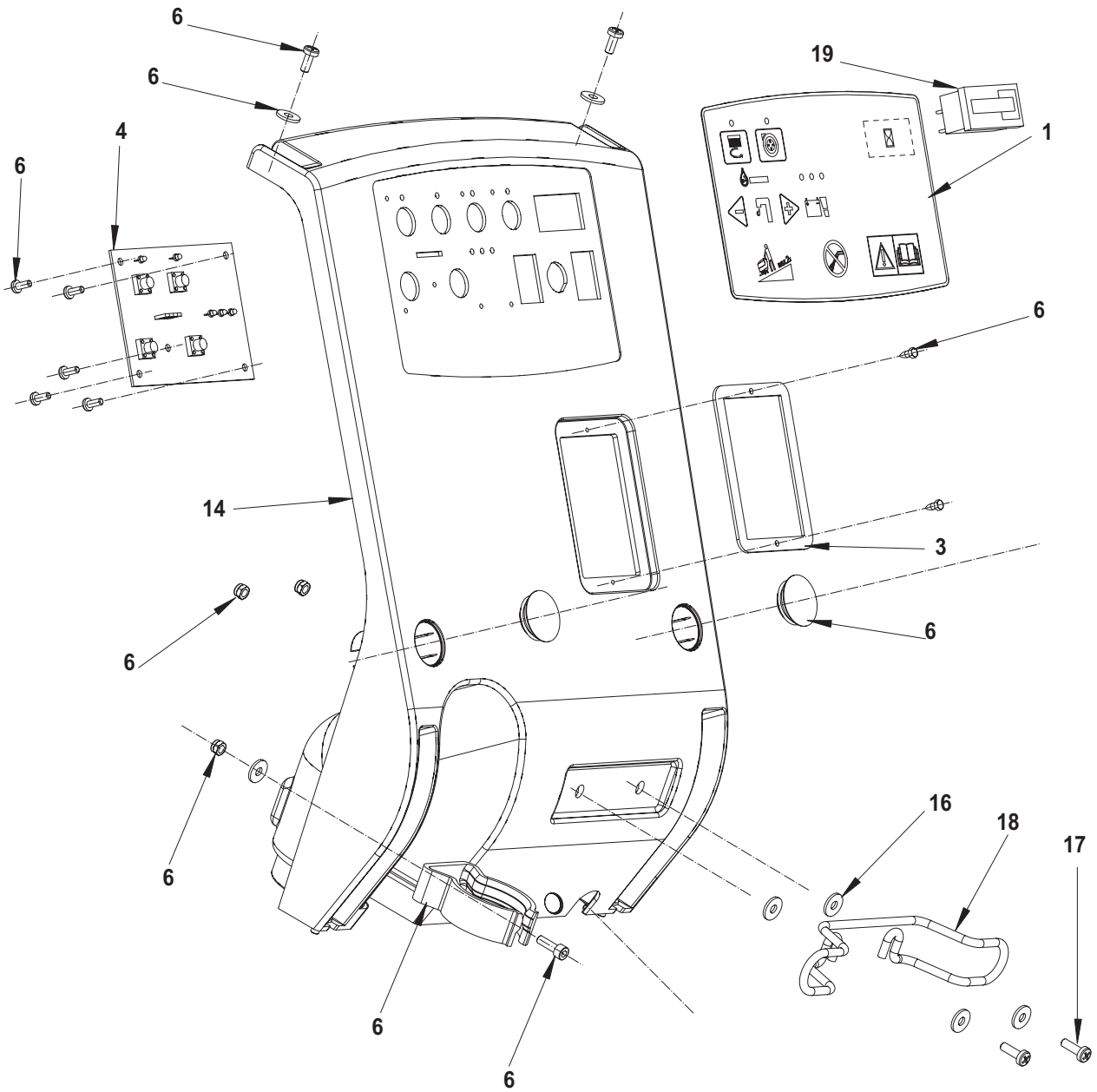

2007-06	CONTROL PANEL SYSTEM			
2009-06	Razor™ 20			25

Item No.	Ref. No.	Qty	Description
1	909 6099 000	1	DECAL CONTROL PANEL
3	909 6545 000	1	GASKET
4	9097006000	1	ELECTRONIC CARD
6	9098302000	1	HARDWARE CONTROL PANEL KIT
14	9097649000	1	COVER CONTROL PANEL KIT
16	145 1261 000	4	WASHER
17	146 2090 000	2	SCREW CYL HD M5X16
18	909 5149 000	1	SUPPORT BATTERY CHARGER CABLE
19*	9096951000	1	COUNTER HOUR 24V
	9096952000	1	INSTALLATION INSTRUCTIONS COUNTER HOUR KIT
[21]	145 8368 000	1	FUSE 3A

2007-06	CONTROL PANEL SYSTEM			
2009-06	Razor™ 20T			27

Item No.	Ref. No.	Qty	Description
1	9097029000	1	DECAL CONTROL PANEL
2	9097007000	1	ELECTRONIC CARD
4	909 6545 000	1	GASKET
6	9098302000	1	HARDWARE CONTROL PANEL KIT
12	146 2888 000	1	KEY SWITCH
14	9097649000	1	COVER CONTROL PANEL KIT
16	909 6675 000	2	O-RING 132
17	145 1261 000	4	WASHER
18	146 2090 000	2	SCREW CYL HD M5X16
19	909 5149 000	1	SUPPORT BATTERY CHARGER CABLE
21*	9096951000	1	COUNTER HOUR 24V
22	146 2887 000	1	KEY
	9096952000	1	INSTALLATION INSTRUCTIONS COUNTER HOUR KIT
[24]	145 8368 000	2	FUSE 3A
[25]	909 6678 000	1	FUSE 20A

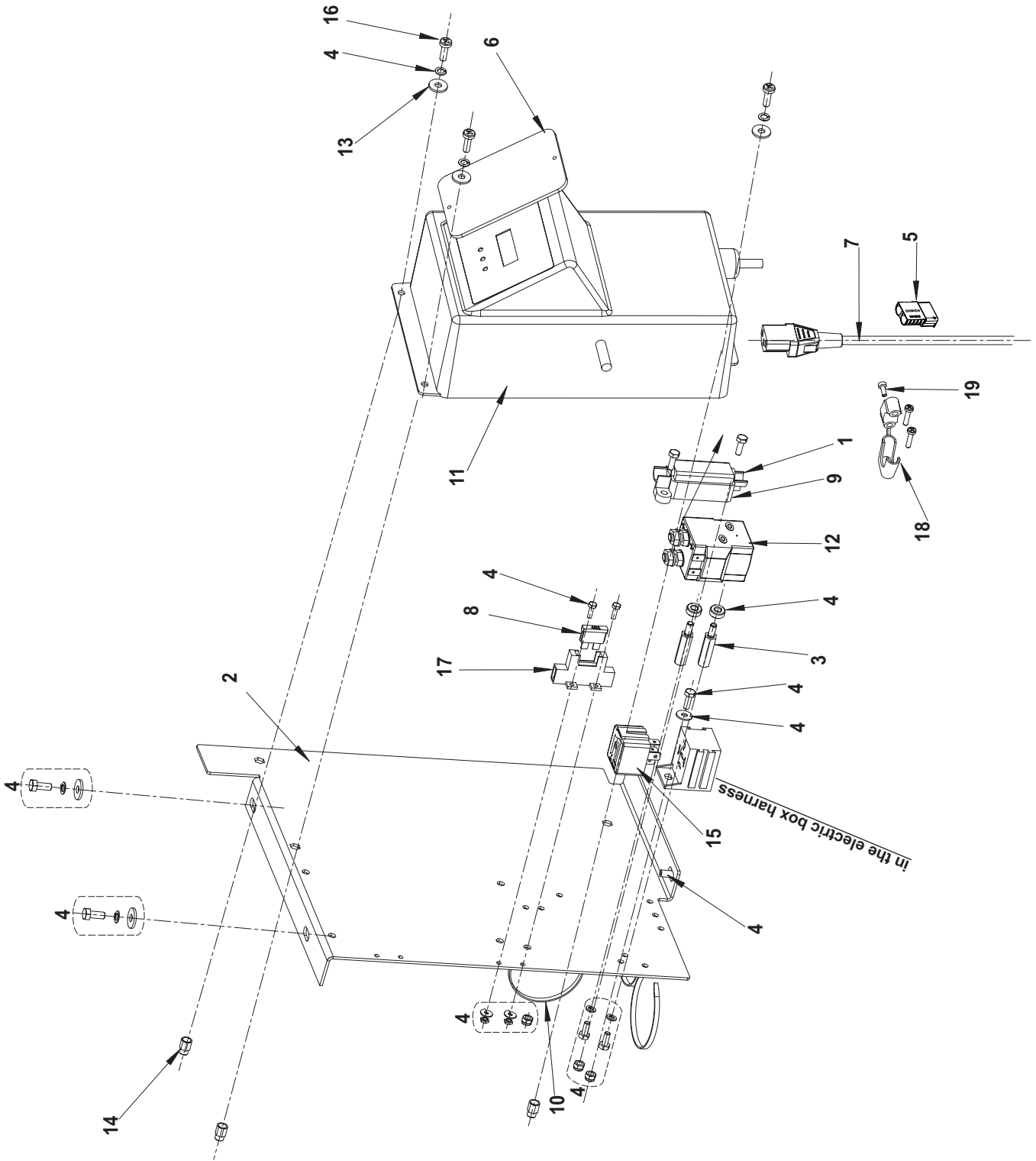

2007-06

ELECTRICAL COMPONENTS

2009-06

Razor™ 20

29

Item No.	Ref. No.	Qty	Description
1	145 8046 000	1	FUSE HOLDER
2	909 6498 000	1	SUPPORT
3	909 6676 000	2	SPACER M4 L=25
4	9098303000	1	HARDWARE ELECTRIC SYSTEM KIT
5	146 1986 000	1	CONNECTOR 120A
6	909 5313 000	1	INSPECTION PLATE
7	9096914000	1	CABLE EXTENTION
8	145 8513 000	1	FUSE 30A
9	145 3824 000	1	STRIP FUSE 40A
10	145 1449 000	3	CLAMP
11	9098297000	1	BATTERY CHARGER 24V 13A
12	9097208000	1	ELECTROMAGNETIC SWITCH 24V
13	33005913	3	WASHER M6 UNI6592
14	145 6132 000	3	INSERT M5
15	909 6622 000	1	RELAY 24V 40A
16	146 1711 000	3	SCREW M5X20 UNI7687
17	146 0660 000	2	BLADE FUSE HOLDER
18	L08338600	1	CABLE HOLDER
19	146 1788 000	1	SCREW M4X12
[20]	L08812093	4	COVER, BATTERY TERMINAL
[21]	9096963000	1	HARNESS ELECTRIC BOX
[22]	9096971000	1	MACHINE HARNESS
[23]	909 6840 000	1	HARNESS VACUUM CLEANER
[24]	9097565000	1	BATTERY HARNESS

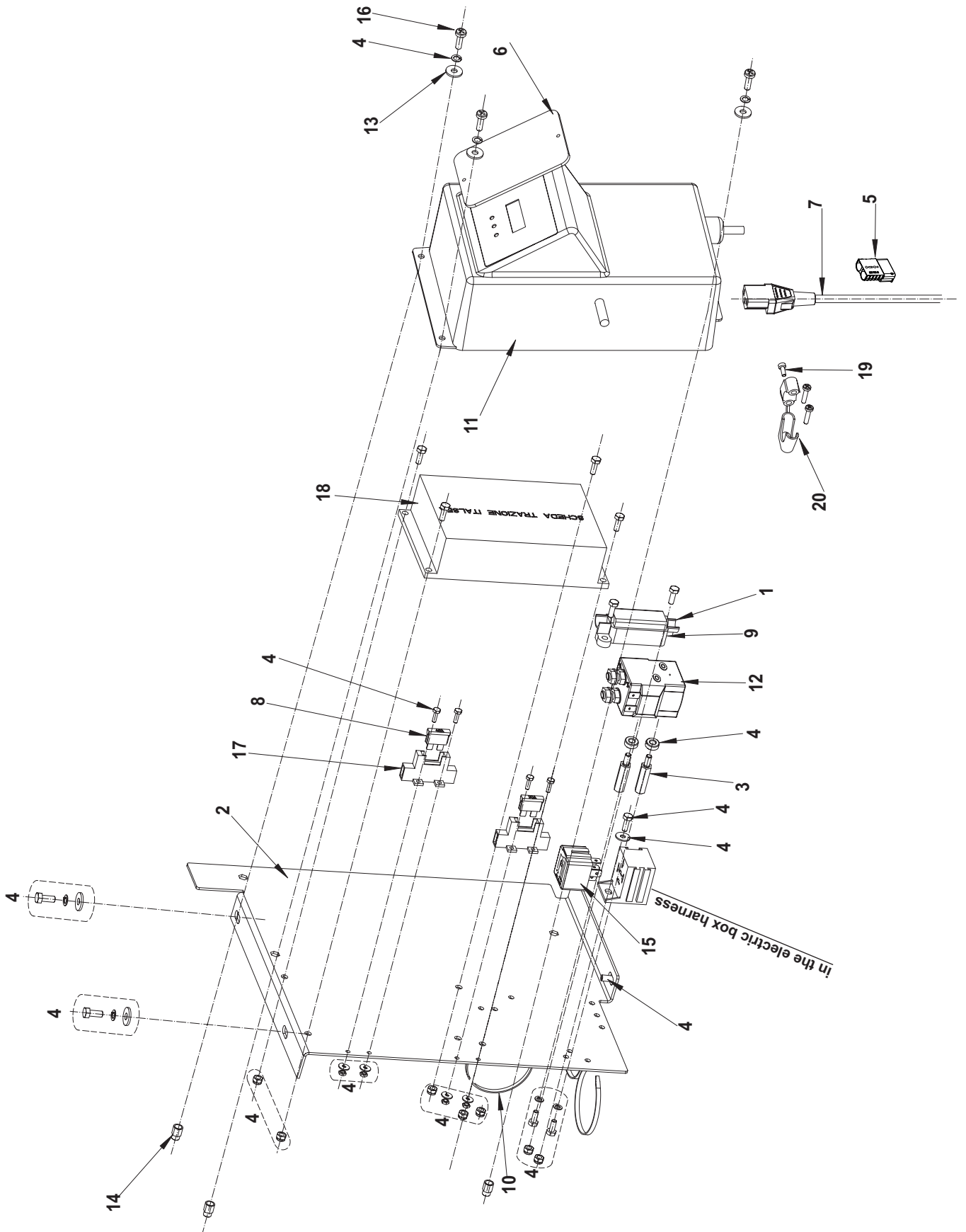

2007-06

ELECTRICAL COMPONENTS

2009-06

Razor™ 20T

31

Item No.	Ref. No.	Qty	Description
1	145 8046 000	1	FUSE HOLDER
2	909 6498 000	1	SUPPORT
3	909 6676 000	2	SPACER M4 L=25
4	9098303000	1	HARDWARE ELECTRIC SYSTEM KIT
5	146 1986 000	1	CONNECTOR 120A
6	909 5313 000	1	INSPECTION PLATE
7	9096914000	1	CABLE EXTENTION J
8	145 8513 000	2	FUSE 30A
9	145 3824 000	1	STRIP FUSE 40A
10	145 1449 000	3	CLAMP
11	9098297000	1	BATTERY CHARGER 24V 13A
12	9097209000	1	ELECTROMAGNETIC SWITCH 24V
13	33005913	3	WASHER M6 UNI6592
14	145 6132 000	3	INSERT M5
15	909 6622 000	1	RELAY 24V 40A
16	146 1711 000	3	SCREW M5X20 UNI7687
17	146 0660 000	2	BLADE FUSE HOLDER
18	9096908000	1	ELECTRONIC CARD, TRACTION
19	146 1788 000	1	SCREW M4X12
20	L08338600	1	CABLE HOLDER
[21]	L08812093	4	COVER BATTERY TERMINAL
[22]	9096964000	1	HARNESS ELECTRIC BOX
[23]	9096972000	1	MACHINE HARNESS
[24]	909 6840 000	1	HARNESS VACUUM MOTOR
[25]	9097565000	1	BATTERY HARNESS

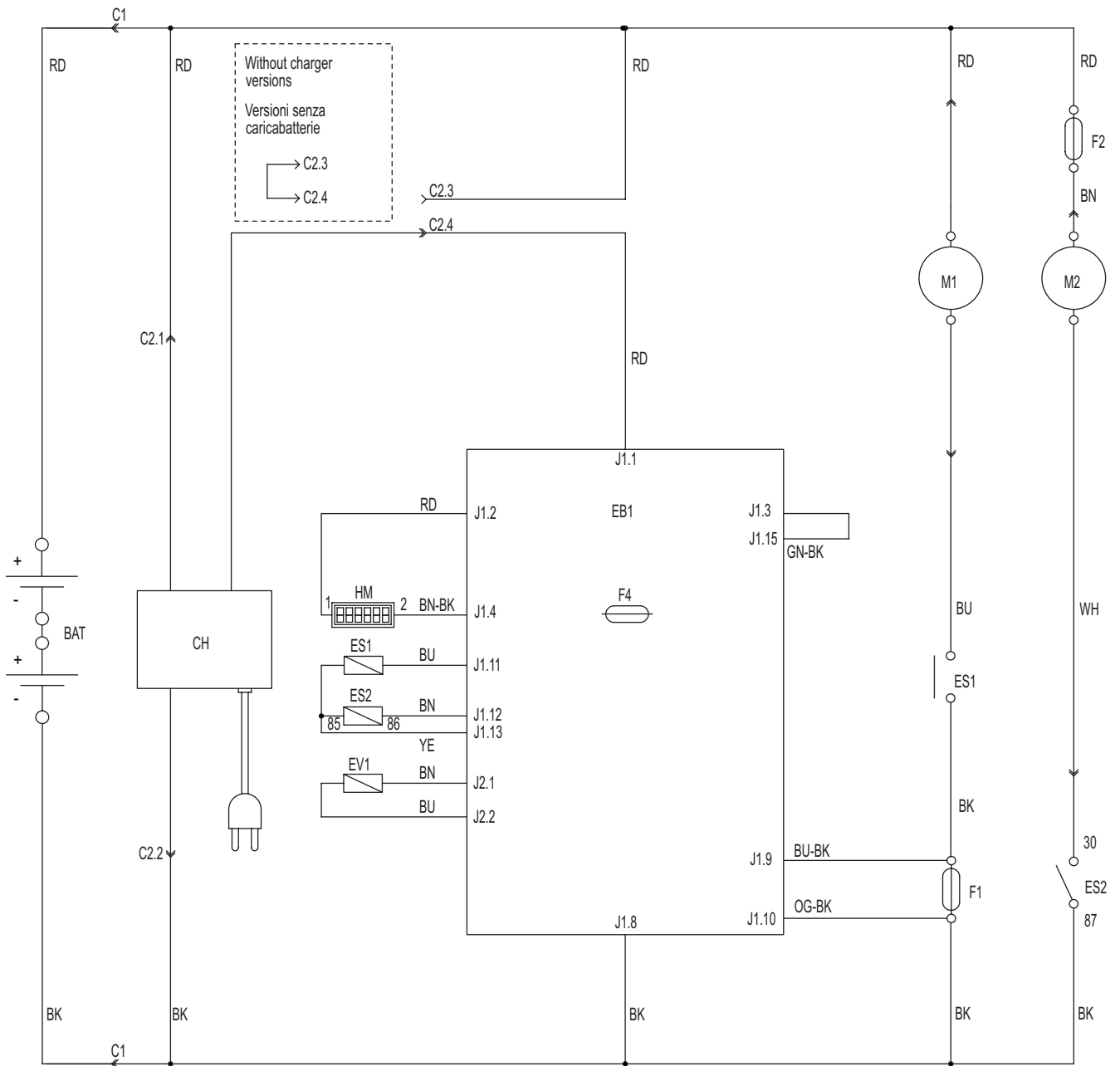

WIRING DIAGRAM

Rev. A

909 6530 000

COMPONENTS / COMPONENTI	
BAT	24V BATTERIES
C1	BATTERY CONNECTOR
C2	CHARGER CONNECTOR
CH	BATTERY CHARGER
CS	BRUSH DECK CONNECTOR
EB1	CONTROL PANEL BOARD
ES1	BRUSH MOTOR ELECTROM. SWITCH
ES2	VACUUM MOTOR ELECTROM. SWITCH
EV1	WATER ELECTROVALVE
F1	BRUSH DECK FUSE
F2	VACUUM MOTOR FUSE
F4	LOW POWER CIRCUIT FUSE
HM	HOURLY METER (OPT)
M1	BRUSH MOTOR
M2	VACUUM MOTOR

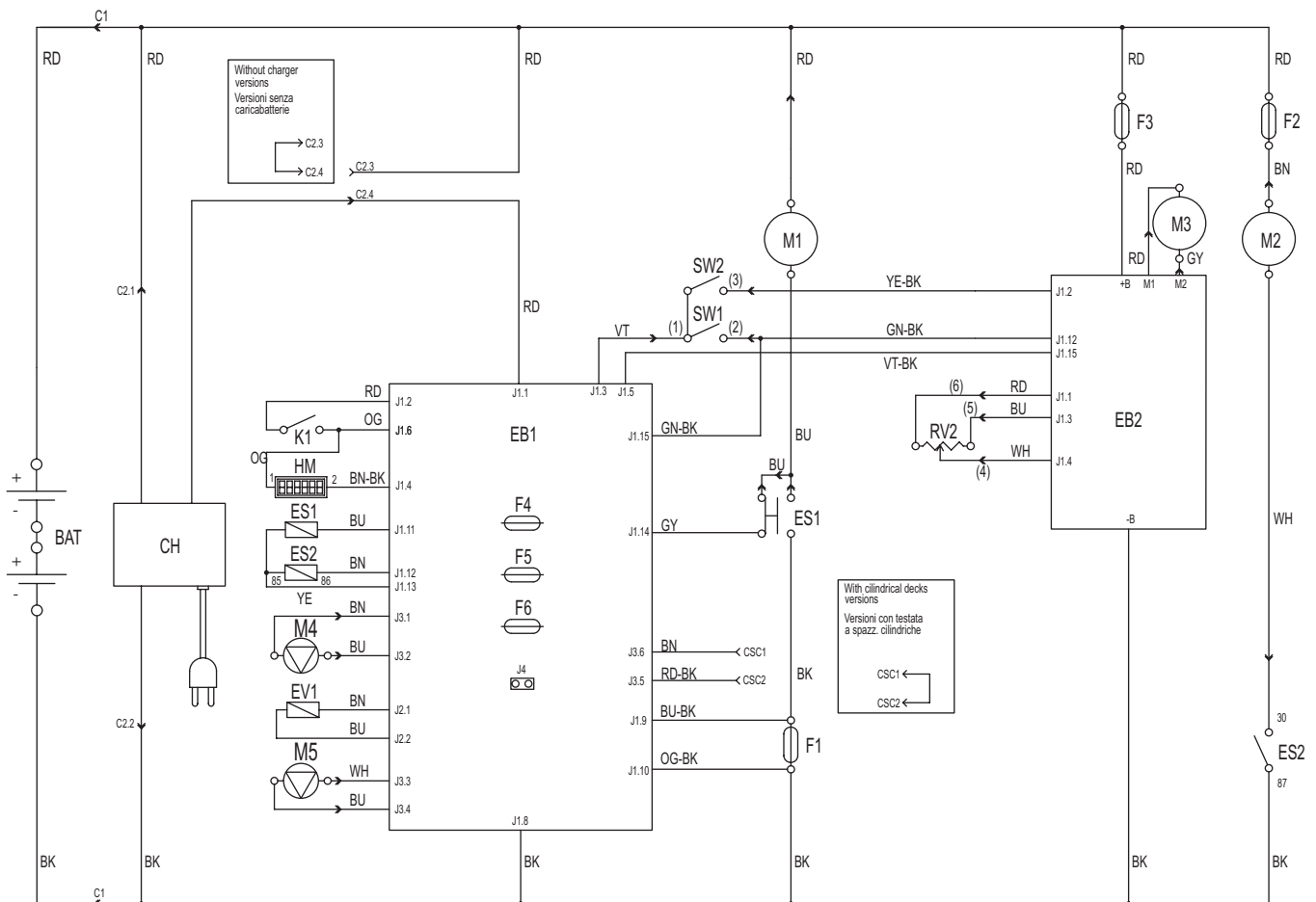

WIRING DIAGRAM

9096909000

COMPONENTS / COMPONENTI			
BAT	24V BATTERIES	K1	KEY SWITCH
C1	BATTERY CONNECTOR	M1	BRUSH MOTOR
C2	CHARGER CONNECTOR	M2	VACUUM MOTOR
CH	BATTERY CHARGER	M3	DRIVE MOTOR
CSC	CILINDRICAL DECK SECONDARY CONNECTOR	M4	WATER PUMP (OPT)
EB1	CONTROL PANEL BOARD	M5	DETERGENT PUMP (OPT)
EB2	DRIVE ELECTRONIC BOARD	RV2	MAX SPEED POTENTIOMETER
ES1	BRUSH MOTOR ELECTROM. SWITCH	SW1	BRUSHES / DRIVE MICROSWITCH
ES2	VACUUM MOTOR ELECTROM. SWITCH	SW2	REV. GEAR MICROSWITCH
EV1	ELECTROVALVE		
F1	BRUSH DECK FUSE		
F2	VACUUM MOTOR FUSE		
F3	DRIVE SYSTEM FUSE		
F4	LOW POWER CIRCUIT FUSE		
F5	BRUSH RELEASE FUSE		
F6	PUMP FUSE		
HM	HOURMETER (OPT)		

RECOMMENDED SPARE PARTS

2007-06

34

Razor™ 20 - 20T

2011-11

Ref. No. DESCRIPTION QTY MACHINES

SOLUTION TANK

9097192000 WATER FILTER INLET 1 20 - 20T
 9098265000 SOLUTION TANK HARDWARE KIT 1 20 - 20T

RECOVERY TANK

9099166000 HOSE VACUUM 1 20 - 20T
 L08812259 CAGE, FLOAT 1 20 - 20T
 L08812373 BALL FLOAT 1 20 - 20T
 9097726000 CAGE FLOAT HOLDER KIT 1 20 - 20T
 145 0543 000 HOSE CLAMP 2 20 - 20T
 909 6877 000 HARDWARE MOTOR FIXING KIT 1 20 - 20T
 # 9099401000 MOTOR VACUUM W/CONNECTOR KIT 1 20 - 20T
 909 6491 000 VACUUM MOTOR PANEL ACOUSTIC INSULATION 1 20 - 20T
 # 909 918000 GASKET VACUUM MOTOR 1 20 - 20T
 # 909 6490 000 GASKET VACUUM MOTOR 1 20 - 20T
 9097169000 GASKET VACUUM MOTOR 1 20 - 20T
 909 6672 000 FILTER 1 20 - 20T
 # 909 5371 000 CARBON BRUSH FOR VACUUM MOTOR 2 20 - 20T

CHASSIS SYSTEM

9099028000 WHEEL CASTOR KIT 1 20
 909 6878 000 CHASSIS SYSTEM HARDWARE KIT 1 20 - 20T

WHEEL SYSTEMS

909 6548 000 MOTOR DRIVE 24V 200W 1 20T
 145 5124 000 CARBON BRUSH FOR DRIVE MOTOR 2 20T
 # 9099204000 WHEEL FRONT DRIVE D.200 2 20T
 909 6507 000 WHEEL FRONT D.200 2 20

HANDLE ASSEMBLY

L08812282 CAM HANDLE MICROSWITCH 1 20T
 9096923000 CAM HANDLE MICROSWITCH 1 20T
 9098300000 HARDWARE HANDLE FIXING KIT 1 20T

SOLUTION SYSTEM

9096994000 VALVE ELBOW 1 20 - 20T
 9097166000 FILTER KIT CPL 1 20 - 20T
 9097170000 PIPES SOLENOID VALVE KIT 1 20 - 20T
 909 6555 000 SOLENOID VALVE 24V 1 20 - 20T

SQUEEGEE SYSTEM

909 6055 000 FRONT STRAP 2 20 - 20T
 909 6044 000 WELDMENT SQUEEGEE TOOL 1 20 - 20T
 9097637000 SQUEEGEE FIXING KIT 2 20 - 20T
 909 6551 000 KNOB 8X30 SS 1 20 - 20T
 909 6484 000 REAR BLADE SQUEEGEE 1 20 - 20T
 909 6483 000 FRONT BLADE SQUEEGEE 1 20 - 20T
 909 6882 000 HARDWARE SQUEEGEE BLADE FIXING KIT 1 20 - 20T
 909 6883 000 WHEEL SQUEEGEE KIT 1 20 - 20T
 909 6884 000 ROLLER BUMPER SQUEEGEE KIT 1 20 - 20T
 909 6885 000 SQUEEGEE SUPPORT HARDWARE KIT 1 20 - 20T
 909 6394 000 LATCH SQUEEGEE KIT 1 20 - 20T

Ref. No.	DESCRIPTION	QTY	MACHINES
----------	-------------	-----	----------

BRUSH SYSTEMS

	909 6042 000	BRUSH DECK	1	20 - 20T
	909 6853 000	BRUSH DECK KIT	1	20T
#	9098308000	REDUCTIONGEARMOTOR 450W	1	20 - 20T
#	9098376000	CARBON BRUSH KIT FOR 9098308000 (AMER)	1	20 - 20T
	909 6887 000	ROLLER BUMPER KIT	1	20 - 20T
	L08601624	FITTING 1/4	1	20 - 20T
#	9099419000	BRUSH SYSTEM HARDWARE KIT	1	20 - 20T
	9097184000	VIBRATION DAMPING	1	20 - 20T
	L08837018	PAD HOLDER	1	20 - 20T
	9097093000	HOLDER POLYGONAL W/FLANGE	1	20 - 20T

CONTROL PANEL SYSTEMS

	909 6099 000	DECAL CONTROL PANEL	1	20
	9097029000	DECAL CONTROL PANEL	1	20T
	9097008000	ELECTRONIC CARD	1	20
	9097009000	ELECTRONIC CARD	1	20T
	146 2888 000	ON/OFF KEY SWITCH	1	20T
	146 2887 000	KEY	1	20T

ELECTRICAL SYSTEMS

	9096908000	CARD ELECTRONIC TRACTION	1	20T
	146 1986 000	CONNECTOR BATTERY	1	20 - 20T
	146 0719 000	SWITCH ELECTROMAGNETIC 24V	1	20
	909 5127 000	SWITCH ELECTROMAGNETIC 24V	1	20T
	909 6622 000	RELAY 24V 40A	1	20 - 20T
	145 3824 000	FUSE STRIP 40A	1	20 - 20T
	145 8513 000	FUSE BLADE 30A UL	1	20 - 20T
	145 8368 000	FUSE 3A	1	20 - 20T
	9098297000	BATTERY CHARGER 24V 13A 100-240V 50/60HZ	1	20 - 20T

ACCESSORIES

	9096916000	FILTER SOLUTION TANK	1	20 - 20T
	909 6848 000	BRUSH DECK W/SQUEEGEE KIT	1	20T
	L08837025	BRUSH PROLENE 530MM	1	20 - 20T
	L08837026	BRUSH PROLITE 530MM	1	20 - 20T
	L08837027	BRUSH UNION MIX 530MM	1	20 - 20T
	L08837028	BRUSH MIDLITE GRIT 530MM	1	20 - 20T
	L08837029	BRUSH MID GRIT 240 530MM	1	20 - 20T
	L08837065	BRUSH MAGNA GRIT 46 530MM	1	20 - 20T
	L08837066	BRUSH DYNA GRIT 80 530MM	1	20 - 20T
	L08837067	BRUSH AGLITE GRIT 500 530MM	1	20 - 20T
	L08603878	SQUEEGEE KIT	1	20 - 20T
	909 6860 000	BLADES NEOPRENE KIT 30"	1	20 - 20T
	909 6858 000	BLADES POLYURET. KIT 30"	1	20 - 20T
	9097185000	EXTRA PRESSURE KIT	1	20 - 20T
	9096951000	COUNTER HOUR	1	20 - 20T
	9097167000	WHEEL FRONT D.200 65SH	2	20
	9097032000	WHEEL FRONT D.200 DRIVE 65SH	2	20T

KENT

Simple. Clean.

14600 21st Avenue North
Plymouth, MN 55447-3408

www.kenteuroclean.com

Phone: 800-334-1083

Fax: 866-261-4779

©2011 Nilfisk-Advance, Inc.

A Nilfisk-Advance Brand